



# Designing Engineering Solutions to Surgical Problems: How to Translate Physiology to Biomechanics

Orit Braun Benyamin<sup>1</sup> · David Juvinao<sup>2</sup> ·  
Tzach Berlinsky<sup>2</sup> · Adham Salih<sup>1</sup> · Evgeny Solomonov<sup>3</sup> ·  
Igor Waksman<sup>4</sup> · Seema Biswas<sup>4</sup> 

Received: 22 June 2021 / Accepted: 18 June 2022 / Published online: 6 August 2022  
© The Institution of Engineers (India) 2022

**Abstract** Asking an engineer to design a solution to a surgical problem requires a process of explanation, mutual understanding, the testing of concepts, and a rich exchange of ideas. Key to the process is isolating the exact biological process the engineers are being asked to replicate. This is a challenge for both the doctor and the engineer. In this article, it has been described the progress through a mechanical engineering course where physiological processes become translated into biomechanical work. Using the example of building a simulated carotid pulse into the neck of a defunct intubation (head and neck) model, it has been illustrated the process of teaching and learning as both teachers and students bring the worlds of medicine and engineering together to develop an understanding essential to the simulation of biology in machines. The future of medicine and surgery is integrally related to advances in technology and engineering.

**Keywords** Surgical simulation · Trauma simulation · Mannequins · Mechanical engineering

## Introduction

Braude College in Karmiel, in the north of Israel, trains engineers in Galilee through a practical and interactive curriculum. There is an emphasis on engineering for the community across all engineering disciplines [1, 2]. The mechanical engineering department, in particular, has a long history of designing, adapting, and producing devices for members of the community living with disease or disability, and working with doctors, nurses, physical therapists, and occupational therapists to produce individualized products that patients and the public may keep and use at no cost to them. While engineering tutors and students may work with a single client on a project over several months (usually six months—2 semesters), a new course Designing Engineering Solutions to Surgical Problems has been developed to maximize the exposure of engineering students to a number of doctors with ideas they would like to see developed by engineers. The emphasis of this course is to convert physiological models in biology to mechanical processes in engineering so that the human body, its functions, and dysfunctions are better understood by doctors, engineers, and the students of both disciplines. In describing the process of construction of the simulation model, the authors tried to show that medical simulation may extend far beyond a standard simulation model where trainees practice a skill. With this model trainees have to elicit physical clinical signs that their trainers can change on a dynamic model, trainees' evaluation of those signs and clinical decision making is tested on the same model, and, clinical intervention may be performed on that same model. This is unique and changes medical simulation training from passive to active.

Training through simulation in surgery and trauma is increasingly common as trainee working hours spent gaining hands-on experience, the growth of specialist units,

✉ Seema Biswas  
seemabiswas@msn.com

<sup>1</sup> Mechanical Engineering, Braude College, Karmiel, Galilee, Israel

<sup>2</sup> Braude College, Karmiel, Galilee, Israel

<sup>3</sup> General Surgery, Ziv Medical Center, Karmiel, Galilee, Israel

<sup>4</sup> General Surgery, Galilee Medical Center, Nahariya, Galilee, Israel

and modern professional, legal and ethical medical practice cumulatively reduce the trainees' physical contact with patients. This is especially of concern in acute and trauma care settings where crucial life-saving decisions based on immediate clinical assessment are deferred to the most senior and experienced clinician in the room. While regular training using simulation scenarios effectively foster teamwork and familiarity with management protocols, simulation falls down in the authentic replication of clinical signs and may substantially limit learning value as training loses focus on physical examination findings with the visual and tactile cues essential to rapid assessment and decision making [3–6].

## Materials and Methods

### Explaining the Brief

The carotid pulse is described as a “central” pulse. Close to the heart, the feel of the carotid pulse, simply pushing gently with a finger against the patient's skin at the pulse-point (beneath the angle of the mandible), gives the doctor in the trauma room an immediate idea of the patient's circulating blood volume. This is only an idea, but to an experienced clinician, this is instant useful information about the hemodynamic status of a patient who might be in the stages of shock, especially in combination with other visual cues. A patient who has lost a lot of blood would be expected to have a fast, but weak, “thready” pulse. Cardiac output is enhanced by increasing the rate at which a relatively empty left ventricle contracts. As the patient continues to bleed and blood volume reduces still further, the pulse will become further attenuated and eventually disappear. What the doctor palpates or feels is the diminishing volume or character of the pulse. While a normal pulse rate (70 bpm), fast (100 bpm), and really fast (140 bpm) pulse may be easily simulated, simulating the “character” (the volume felt) of the pulse is the potential challenge. Understanding exactly how the pulse feels is what the doctor needs to communicate effectively to the engineering team.

The current work begins by feeling own carotid pulse—two fingers palpating below the angle of the mandible. Then it has been palpated each other's carotid pulse. A faster pulse is elicited simply by exercising—jogging on the spot, for example. This pulse feels different from the fast pulse of a trauma patient who may be bleeding, however. The rapid pulse of a healthy individual is fast and strong in character—effectively, more blood is being pumped around the body as a normal physiological response to the increase in demand for oxygen from exercising muscle. The trauma scenario with blood loss is pathophysiological: the circulating volume of blood is decreased, the heart compensates

by beating faster, but there is less blood to pump out of the heart; thus, what the doctor in the trauma room feels is a fast but weak pulse. This can be described to the engineering team but the actual feel of the pulse cannot be replicated. An essential part of the design brief is, therefore, absent, as the engineers are being asked to create a simulated model of a pathological pulse that only the doctor would feel in the trauma room. Translating this pathophysiology into biomechanics becomes an issue.

The discussion between the doctors and engineers exposes some interesting paradigms: The most intuitive solution for a doctor is to simulate the character and rate of the carotid pulse using an anatomical model of the heart, aortic arch, and carotid arteries. Changing the rate and volume of a liquid pumped out of the left ventricle into an elastic and compliant arterial system of tubes that transmit both volume and pressure simulates the rate and volume changes expected in the simulated carotid pulse palpated beneath simulated skin. On closer examination of what precisely is required, however, it is only the carotid pulse that needs to be palpated in the neck. The only functional requirements are a normal, fast, and very fast pulse with a strong, weak, or almost impalpable character. The brief does not require the construction of a simulated cardiovascular system.

Meeting the brief depends absolutely on the authenticity of the simulated carotid pulse and each of its variations.

### Developing a Concept

The engineering design process includes a series of steps which organize engineering ideas toward the production of potential solutions to the engineering challenges (Fig. 1). In this, it was broken up the design process into distinct stages and demonstrate these using the process the students went through during the course.

### Real Need for this Project

Students work in pairs and proceed through the initial steps involved in the engineering design project selected by them. They begin by reviewing the steps of the engineering design defining the client need for the project. This is achieved by discussing the brief with the doctor, understanding the medical situation, the exact needs of training, the anatomy, physiology, and pathophysiology involved, and the consequences of creating a poor versus realistic simulation model. In reality, this conversation continues throughout the process. It is essential to a mutual understanding of what is required, why, and what is realistically possible for the engineer.

With this information, the engineering students construct a precise problem definition and examine the requirements and limitations of the project. In the design of the carotid pulse, the students were presented with a scenario of an

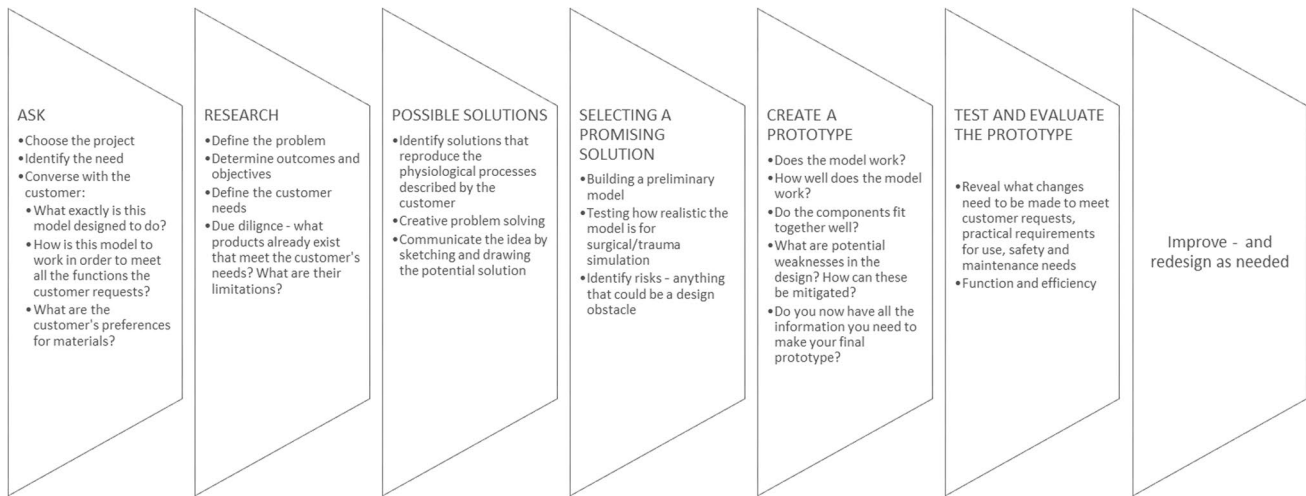

**Fig. 1** Course design process

injured man arriving at the hospital trauma room by the doctor. The students watched, listened, and questioned, trying to gain important insights into the clinical context, the exact significance of the pulse, what abnormalities might be felt and how, and how these clinical findings prompt immediate clinical decisions.

In this discussion, a number of questions arise: why is this so important, is this information not already available on a clinical monitor, is there a better process than clinical palpation that might be engineered, exactly what is being palpated, what does the pulse feel like normally, what abnormalities might arise and how might these abnormalities feel. Realistically, in the trauma room, the pulse will either be normal, with a full volume (strong in character), fast but still strong (100 bpm), or really fast—hard to feel and weak or thready in character.

### Research

Researching the brief involves a number of components:

1. a continued understanding of the background in the problem statement
2. due diligence on what engineering solutions already exist
3. the limitations of what already exists in meeting the brief
4. how to adapt what exists
5. what requires innovation
6. what can realistically be produced by a new team of engineering students

In this particular example, the engineering students had a discarded head and neck mannequin used for intubation.

Already damaged and discarded, they were free to make alterations and adaptations to the model.

There are two aspects to design: functions (the physical function of the product: what the product needs to do, and how well) and constraints, which include five general categories: performance, value, size, safety, and special topics. For example, the students may be confronted by a design challenge in building a device small enough to fit within the head of the mannequin. This requirement will constrain the design to a specified dimension solution which has to fit into the head while permitting adjustments and positioning of the system.

Prior to starting a new design project, it makes sense to gain a sense of its scope by looking at what others have done and critically analyzing the designs of others. Thus, the students are required to investigate in some detail the features of existing models—their due diligence research, list their advantages and disadvantages, but also look for insights into the designs that are useful for further innovation. Through this process students are able to identify any weaknesses and strengths in their own design and whether their design can really improve on existing products. Again, the focus remains on the precise brief and repeated checks with the client (the doctor) about what they require and why existing solutions may or may not meet their requirements.

### Product Design Process

**Possible Solutions** Conceptual design is the very first stage of the product design process (Fig. 1), where drawings are used to explain the proposed product: what it should do, how it should behave, and what it should look like in a way that is understandable and acceptable to the people using it. Students at Braude College of Engineering study conceptual

design by using a methodology that deals with one or a few critical conceptual issues at a time, developing these concepts as configurations while evaluating the evolving design to identify new, emerging issues at the conceptual level before implementation or model building. The process consists of cycles that include the following steps: (1) parameter identification (PI), recognizing important conceptual issues, (2) creative synthesis (CS), generating a configuration, or hardware that builds on a previous concept, (3) evaluation (E), and, assessing the last configuration [7].

Simulating the physiological sensation of the pulse rate and the blood volume flow was a critical conceptual issue in the example. During the creative synthesis stage, a system with a pump (the simulated heart) connected to tubes (simulated arteries) filled with fluid (simulated blood) that would transmit a pulse generated by the pump, was chosen. The tubes would need to replicate the expansile pulsation of real arteries. Thus, both anatomy and physiology would be built simulations. The students quickly realized that the mannequin they had was not large enough to accommodate these structures and that any repair or maintenance required would involve deconstruction of the entire system and become a prohibitively long process. In addition, it was estimated that the components would be so heavy that the models would no longer be portable. One possible solution was to externalise the pump—but this was not in keeping with the principle of palpating the pulse in the neck of the mannequin and would likely generate a distracting noise. Through the conceptual design process, the students realized that mimicking the physiological phenomenon could allow the implantation of a motor through which the frequency and amplitude of the ‘pulse’ can be controlled. Thus, the force felt by the doctor’s fingers placed superficially on the simulated skin of the mannequin can be perceived as the pulse rate and blood volume (the character of the pulse) without the need to construct the anatomy. In biology, anatomy and physiology are understood in the terms “structure determines function”. Here it can be seen what the doctor actually wants to palpate in the neck of the mannequin does not require simulated anatomy; it requires simulated physiology. This is the conceptual solution that converts biological processes into mechanical engineering concepts. This engineering solution fits easily into the adapted intubation head and neck model, with the added bonus that the model may be restored to its primary purpose of intubation practice.

### Create a Prototype

An old, damaged intubation head and neck mannequin were repurposed to insert a simulated right carotid pulse. The pulse is palpated in life and in simulation just below the angle of the mandible as shown in Fig. 2.

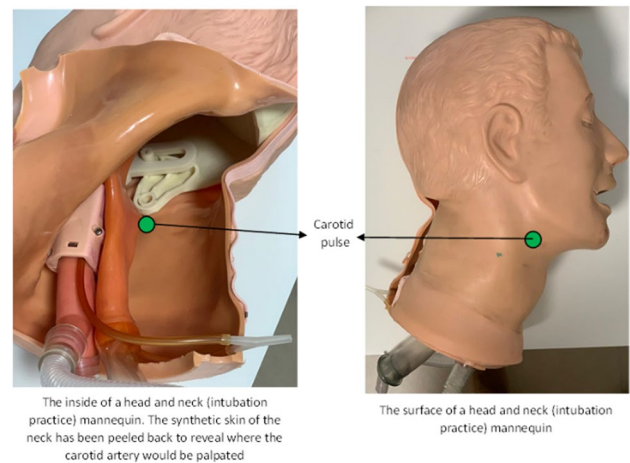

**Fig. 2** Position for finger palpation of carotid pulse

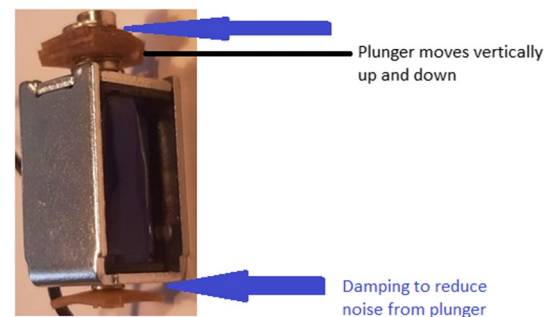

**Fig. 3** The solenoid

A solenoid (Fig. 3) was used to create the sensation of the pulse as the plunger moves up and down at a rate fixed by a microcontroller.

The solenoid was mounted within a 3-D printed frame that connects the head and neck of the mannequin (Fig. 4).

Figure 5a, b show the circuit by which the microcontroller set the rate at which the plunger of the solenoid vibrated to create the sensation of the carotid pulse.

### Test and Evaluate the Prototype

With the solenoid and circuit in place within the mannequin, the simulated skin of the neck was replaced and the doctor palpated the simulated carotid pulse generated by the solenoid (Table 1 shows the Arduino code used). The sensation felt at the fingertips gave information about the preset rate of the pulse. Through the synthetic skin, fingertip sensation (doctors use the pulps of their fingertips as the most sensitive areas for palpation [8, 9]) gave information about the strength (character) of the pulse—strong or weak—dependent on the voltage supplied by the microcontroller (measured between 0 and 5 V). The current drawn by the solenoid from

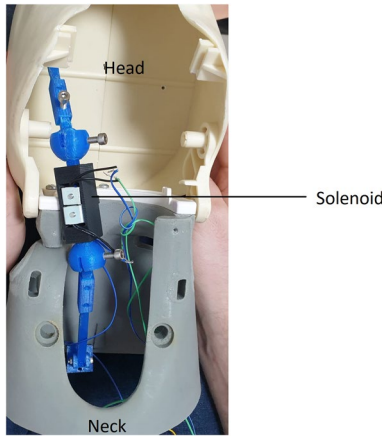

**Fig. 4** Mounting the solenoid within the head and neck of the mannequin

the power supply was measured. The measured current was analogous to the force exerted by the solenoid representing a strong/weak pulse (Fig. 6a–c).

## Results

### Selecting a Promising Solution

A simple circuit was built (Fig. 6): a push–pull solenoid motor was used. The motor connected to an electrical circuit through which frequency and power can be controlled. The motor was placed below the simulated skin that covers the mannequin in the anatomical position of the carotid artery (Fig. 7). The first problem the students encountered was that the small motor did not generate sufficient power to simulate a palpable pulse in the neck. A larger motor created a vibration over too large an area in the neck (rather than the area

where the carotid pulse would be palpated). The students had to, therefore, find a small motor that created sufficient power to generate a well-localized carotid pulse. The push–pull solenoid motor is lightweight, affordable, and, most importantly, has the potential to generate a simulated pulse anywhere in the model (the other side of the neck or the femoral arteries, for example).

The device allows the change of pulse rate and blood volume flow by controlling the amplitude and power of the motor via the microcontroller: (1) normal heart rate and strong pulse (70 bpm), (2) fast pulse but still strong (100 bpm), (3) fast pulse but weak and thready (140 bpm).

The motor was held in place within the mannequin using 3-D printed connectors that fitted comfortably within the mannequin while still permitting neck flexion and extension so the repaired model may also be used for intubation. Only one system (right carotid pulse) was created but there remains space within the neck for the left carotid pulse—perhaps with modifications to the existing design - as the design process evolves.

## Discussion

After a preliminary model is constructed a testing approach is a great way to verify whether the system behaves as expected: the performance of materials and components, assessment of the function and performance of subsystems, and verification that overall product capability meets client needs. Testing was performed at two stages during the product development process: preliminary model and final model and, of necessity, is iterative but essential to the process [10].

So much information is learned during the testing process. It is essential that the medical and engineering team test together. The electrical circuit was connected to a power supply, the device inserted into the mannequin and the

**Fig. 5** The circuit

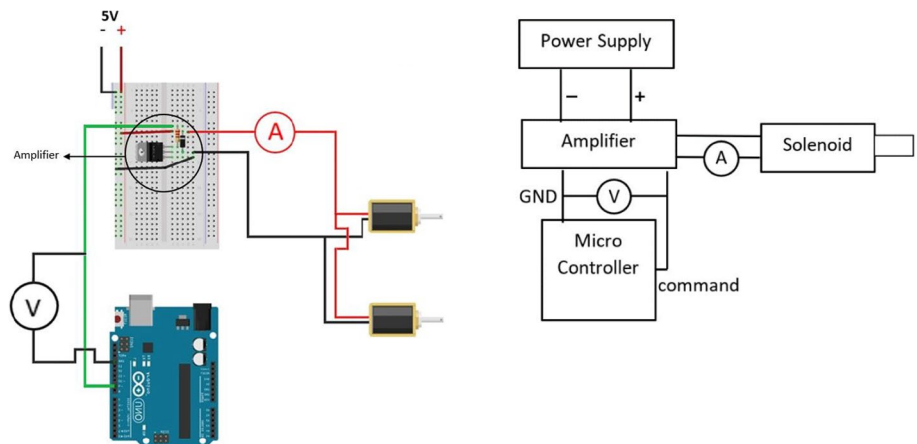

**a** The solenoid in circuit with the microcontroller

**b** Schematic of circuit

**Table 1** Arduino code

ACS723 low Current Sensor Arduino Code	Push Pull Arduino Code
<pre> const int analogInPin = A0; // Number of samples to average the reading over // Change this to make the reading smoother... but beware of buffer overflows! const int avgSamples = 10; int sensorValue = 0; float sensitivity = 100.0 / 500.0; //100mA per 500mV = 0.2 float Vref = 2570; // Output voltage with no current: ~ 2500mV or 2.5V void setup() {   // initialize serial communications at 9600   bps:   Serial.begin(9600); } double VRMS = 0; void loop() {   // read the analog in value:   for (int i = 0; i &lt; avgSamples; i++) {     sensorValue += analogRead(analogInPin);     delay(2);   }   sensorValue = sensorValue / avgSamples;   // The on-board ADC is 10-bits -&gt; 2^10 =   1024 -&gt; 5V / 1024 ~ = 4.88mV   // The voltage is in millivolts   float voltage = 4.88 * sensorValue;   VRMS = (voltage/2.0) * 0.707; </pre>	<pre> int solenoidPin = 9;          //This is the output pin on the Arduino int delaytime=450;          // Set 450 for 70 bpm, 310 for 100 bpm, 225 for 140 bpm void setup() {   pinMode(solenoidPin, OUTPUT);   //Sets that pin as an output }  void loop() {   digitalWrite(solenoidPin, HIGH);   //Switch Solenoid ON   delay(delaytime);   digitalWrite(solenoidPin, LOW);   //Switch Solenoid OFF   delay(delaytime); } </pre>

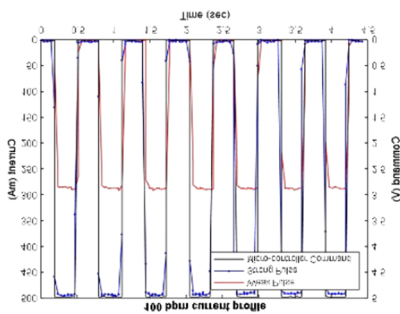

**a** A normal pulse – 70 bpm (expect a strong character simulating a full volume pulse)

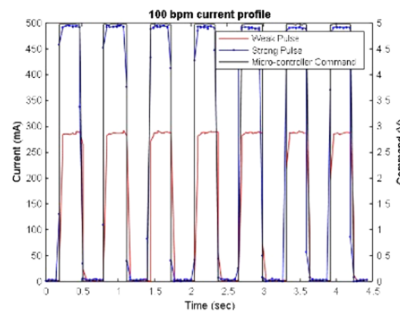

**b** A fast pulse – 100 bpm (may be strong or weak depending on a patient's condition)

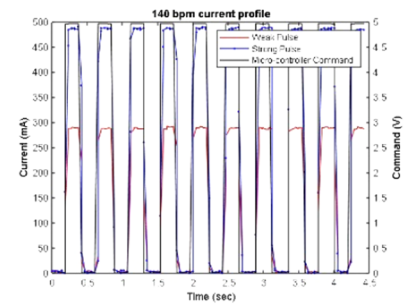

**c** A very fast pulse (expected to be weak in a trauma simulation – indicating a shocked state)

**Fig. 6** Voltage supplied by microcontroller to simulate strong and weak pulse

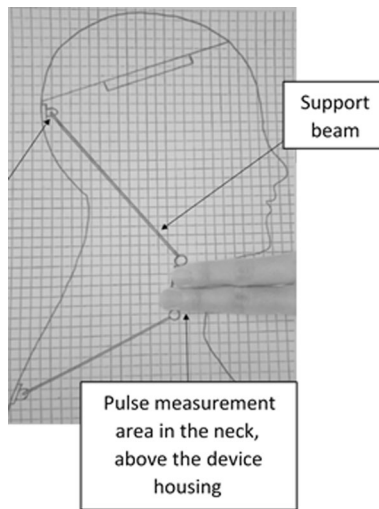

**Fig. 7** Finger palpation of the carotid pulse

doctor palpated the neck through the simulated skin. Testing was performed for all three pulse options: (1) normal heart rate and strong pulse (70 bpm), (2) fast pulse but still strong (100 bpm), (3) fast pulse but weak and thready (140 bpm).

Key findings were that the motor created a loud clicking noise. This was a distraction, eliminated only by the doctor pressing her stethoscope firmly into her ears—a necessary requirement to continue objectively with the test. The actual pulse palpated at all three rates was remarkably life-like. The striking finding was that changing the rate alone created a change in sensation of the volume/character of the pulse. The motor generated sufficient heat to be uncomfortable during palpation, with the added concern that the heat may cause the simulated skin to melt. This problem was never really resolved. As a result, the mannequin can only be used for short periods (up to 10 min). In reality, a teaching scenario in the trauma room would only require the motor to run for a maximum of 10 s at a time, and each teaching scenario would likely last approximately 4 min.

### **Creating a Prototype: Designing a Prototype that Serves as a Proof of Concept**

Prototype-making involves molding and assembly. Emphasis is on the development of a low-cost product. This adds limitations to prototype building. The students were required to fit their prototype into the discarded mannequin—now adapted and repurposed. Thus, the design incorporates the placement of electronic components inside the mannequin, heat removal, safety features, and a user-friendly system of removal and maintenance. Testing the prototype reveals issues that need to be addressed and substantially influences product design.

### **Test and Evaluation of the Prototype**

Prototyping is not intended for the design team to understand real-world implications of their work. Prototyping is used to gain crucial feedback. Testing follows a process: bench testing in the laboratory (that highlighted the heating effect), pre-clinical testing (medical tutors test how well the mannequin functions), and clinical testing (essential feedback once the mannequin is in use in simulator trauma rooms). Focus group analysis and usability tests with the client (the trauma team) give essential feedback and further add to the shared understanding of human physiology and engineering mechanics. COVID-19 restrictions at the time precluded meetings of teams of doctors and engineers but the next steps are to use the prototype for trauma room teaching.

### **Place of the Course in Medicine and Engineering**

The future of medicine and surgery is integrally related to advances in technology and engineering. This course fosters an engagement from the level of student to experienced professional and is a rich environment for the exchange of ideas. No medical or surgical idea results in the exact prototype the doctor envisioned. As this example illustrates, the translation of physiology to biomechanics is not intuitive and is achieved through a process of explanation, understanding, prototyping, and testing. From the students' perspective, bringing the worlds of engineering and medicine together gave them valuable insights into problem-solving translational medical problems. Both students intend to pursue careers in bioengineering and enjoyed getting to grips with human physiology. From the doctor's perspective, watching the engineers simulate physiology rather than anatomy was a lesson in medicine as much as engineering. Both the medical and engineering team gain as much from the process itself as they do from the final product constructed. The next steps have been to see the carotid simulator in use. What is clear is that trainees do focus on feeling the central pulse, do try to decide whether the patient is in shock, do try to gauge the severity of shock based on clinical findings from the model, and only then prepare to intervene. This is unprecedented as medical trainees gain their clinical information from the model and not from the trainer. The intervention they proceed with is based only on their clinical assessment of the model and the decisions they make based on this assessment.

### **Conclusion**

Almost all medical innovations (especially, interventional and surgical) have relied on engineering advances. The disciplines of medicine and engineering go hand-in-hand. As

we proceed through the 21st century, we will need to work closely together to meet global health needs.

**Acknowledgements** The authors would like to thank both the laboratories for their valuable assistance in developing the motor and other related parts.

**Funding** The flagship project and this research are supported by the Planning and Budgeting Committee at the Council of Higher Education of Israel.

#### Declarations

**Conflict of interest** None of the authors has a conflict of interest or competing interest. This device has not yet been patented and has not been manufactured.

#### References

- O. Muller, N. Shalit, O. Braun Benyamin, Students of engineering on behalf of people with disabilities: evaluating the impact of an institution's flagship project. *Front. Educ. IEEE* (2015)
- O. Muller, V. Dangur, B.O. Braun, Developing devices for people with disabilities: challenges and gains of project-based service learning. *Int. J. Eng. Educ.* **35**(5), 1402–1414 (2019)
- S.B. Issenberg, W.C. McGaghie, E.R. Petrusa, G.D. Lee, R.J. Scalese, Features and uses of high-fidelity medical simulations that lead to effective learning: a BEME systematic review. *Med. Teach.* **27**, 10–28 (2005)
- W.C. McGaghie, S.B. Issenberg, J.H. Barsuk, D.B. Wayne, A critical review of simulation-based mastery learning with translational outcomes. *Med. Educ.* **48**, 375–385 (2014)
- F. Escobar-Castillejos, J. Noguez, L. Neri et al., A review of simulators with haptic devices for medical training. *J. Med. Syst.* **40**, 104 (2016). <https://doi.org/10.1007/s10916-016-0459-8>
- J.A. Quick, Simulation training in trauma. *Mo. Med.* **115**(5), 447–450 (2018)
- E. Kroll, Design theory and conceptual design: contrasting functional decomposition and morphology with parameter analysis. *Res. Eng. Design* **24**(2), 165–183 (2013)
- Palapation. JoVE Science Education Database. Physical Examinations I. Cambridge (2021).
- S. Oh, S. Choi, Effects of contact force and vibration frequency on vibrotactile sensitivity during active touch. *IEEE Trans. Haptics.* **12**(4), 645–651 (2019). <https://doi.org/10.1109/TOH.2019.2929521>
- R.K. Sawyer, The iterative and improvisational nature of the creative process. *J. Creat.* **31**, 100002 (2021). <https://doi.org/10.1016/j.yjoc.2021.100002>

**Publisher's Note** Springer Nature remains neutral with regard to jurisdictional claims in published maps and institutional affiliations.