

# DESIGNING THE FLOW-THROUGH PARTS OF DISTRIBUTION SYSTEMS FOR THE PRG SERIES PLANETARY HYDRAULIC MOTORS

**A. Panchenko**

Doctor of Technical Sciences, Professor\*

**A. Voloshin**

Doctor of Technical Sciences, Professor\*

**O. Boltyansky**

PhD, Associate Professor\*

**I. Milaeva**

Senior Lecturer\*

**I. Grechka**

PhD, Associate Professor

Department of theory and computer aided design of mechanisms and machines\*\*

**S. Khovansky**

PhD, Associate Professor

Department of Applied Fluid Aeromechanics

Sumy State University

Rimskoho-Korsakova str., 2, Sumy, Ukraine, 40007

**M. Svyntarenko**

PhD, Associate Professor

Department of heat and gas supply, ventilation and use of thermal secondary energy resources

Kharkiv National university of civil engineering and architecture

Sumska str., 40, Kharkiv, Ukraine, 61002

E-mail: m\_a\_k\_s\_i\_m@ua.fm

**O. Glibko**

PhD, Associate Professor

Department of Geometric Modeling and Computer Graphics\*\*

**M. Maksimova**

PhD, Associate Professor

Department of Fire prevention in settlements

National University of Civil Defence of Ukraine

Chernyshevska str., 94, Kharkiv, Ukraine, 61023

**N. Paranyak**

PhD, Assistant

Department of Civil Safety

Lviv Polytechnic National University

S. Bandery str., 12, Lviv, Ukraine, 79013

\*Department of mobile power tools

Tavria State Agrotechnological University

B. Khmelnytskoho ave., 18, Melitopol, Ukraine, 72310

\*\*National Technical University «Kharkiv Polytechnic Institute»

Kyrpycheva str., 2, Kharkiv, Ukraine, 61002

*Підвищення ефективності використання самохідної техніки визначається наявністю гідромашин для приводів активних робочих органів та ходових систем. У гідроприводах самохідної техніки застосовуються планетарні гідромотори. Перевагою цих гідромоторів є можливість їх установки безпосередньо в приводні механізми бурових машин, транспортерів, лебідок, мотор-колів та ін. Основним вузлом, що лімітує роботу планетарного гідромотора, є розподільна система. Розподільна система створює обертове гідравлічне поле, що забезпечує робочий цикл планетарного гідромотора. Тому удосконалення конструктивних параметрів розподільної системи є актуальним напрямком на шляху поліпшення вихідних характеристик планетарного гідромотора. Розроблена розрахункова схема та запропонований математичний апарат дозволяють досліджувати вплив конструктивних параметрів розподільної системи на вихідні характеристики планетарного гідромотора.*

*Проведеними дослідженнями встановлено, що синхронність обертання гідравлічного поля залежить від кількості робочих камер і характеризується кінематичною схемою розподільної системи. Залежність зміни сумарної площі прохідного перетину розподільних систем для різних кінематичних схем носить циклічний характер з амплітудою коливань, яка залежить від кінематичної схеми. Обґрунтовано раціональні кінематичні схеми розподільних систем. Виявлено зону формування гідравлічних втрат, викликаних місцевими опорами, при проходженні робочої рідини через розподільні вікна золотника і розподільника. Розроблено алгоритм проектування проточних частин, що дозволяє використовувати раціональні кінематичні схеми розподільної системи з метою поліпшення вихідних характеристик планетарного гідромотора*

*Ключові слова: планетарний гідромотор, розподільна система, конструктивні параметри, проточні частини, пропускну здатність*

## 1. Introduction

At present, improving the efficiency of utilization of self-propelled machines is mainly determined by the

hydrofication of active working elements and running systems. The most common hydraulic machines used in the hydraulic drives of self-propelled machinery are the planetary hydraulic machines [1–7]. The planetary hydraulic

machines imply hydraulic machines that operate based on the principle of a planetary reducer, similar to orbital, gerotor, geroler machines, etc. [3–8]. These hydraulic machines are distinguished by low consumption of metal, compactness, good power characteristics, and are exploited as high-torque hydraulic motors for the drives of active working elements of self-propelled machinery. The great advantage of planetary hydraulic motors is a possibility to install them directly into the actuators of drilling machines, conveyors, winches, motor-wheels, etc. [1, 2, 9].

It should be noted that along with the specified advantages planetary hydraulic motors have a rather complex system of distribution of the working fluid. The distribution system is designed to create a rotating hydraulic field, which provides the working cycle of a planetary motor. Rotating hydraulic field plays the part of a planetary reducer in a hydraulic motor [1, 9].

During operation of the planetary-type hydraulic machines, the fluid is fed to the working chambers through the channels and distribution windows, which form the flow-through parts of the distribution system. The parts have a complex geometric shape [10–12]. Local resistance, which is formed by the complex geometry of the flow-through parts in the distribution system, limits the functionality of the planetary hydraulic motor. It reduces its hydraulic and mechanical performance efficiency and power.

Thus, investigating the issues related to the design of flow-through parts of distribution systems of planetary hydraulic motors is a relevant task. It is a priority when designing the volumetric hydraulic machines. Solving the set task would improve output characteristics of planetary hydraulic motors for the drive of active working elements and running systems for agricultural, logging, drilling, construction, road-building, municipal, and other self-propelled machines.

---

## 2. Literature review and problem statement

---

There is a mathematical model of the gerotor pump [3], which describes the change in loads that occur in the gearing. Experimental research into prototypes of the gerotor pumps was conducted. Recommendations regarding the design of rotors for gerotor machines [4] were given. However, the distribution of the fluid into working chambers was not considered.

The researchers in [5] devised a program for designing the hypocycloidal rotor surfaces for gerotor machines. It considers equations of the fluid motion hydrodynamics in the working chambers. A procedure is proposed for designing and manufacturing the rotors for gerotor machines, as well as a technological process of rotor production [6]. The issues related to determining the losses of the working fluid on its way to the working chambers were not considered.

Much attention has been paid to the design of rotors for the gerotor hydraulic machines using the software packages [7] that make it possible to reduce the time to design and test new structures of the gerotor machines and to improve their productivity. However, the influence of geometrical parameters of flow-through parts in a distribution system on the output characteristics of gerotor hydraulic machines was not investigated.

The adequacy of the model, which describes tribological changes in the geometry of the working surfaces of rotors in

orbital hydraulic motors at wear [8], was confirmed by experimental studies. However, the motion of liquid along the feed channels of hydraulic motor was not studied.

It was proposed to estimate a working fluid flow rate in the gerotor hydraulic machines [10] with the help of dimensionless parameters, however, hydraulic losses were disregarded.

Modeling the working fluid flow along the channels of gerotor hydraulic motors [11] substantiates causes for the occurrence of cavitation phenomena in the distribution zone [12]. Determining the losses in the flow-through parts of the distribution systems was not considered.

Paper [13] examines the forces that act in the gearing of a gerotor pump. It takes into consideration the working fluid compression. Some recommendations regarding the design of the gerotor pumps were given. The authors did not address issues related to local hydraulic losses in the gerotor hydraulic machine.

Based on geometric, mathematical, and hydrodynamic models, which are given in other papers [14, 15], theoretical studies into the influence of geometrical parameters of flow-through parts of the gerotor pump on its output characteristics were conducted. It should be noted that the operation of the gerotor pump rotors differs fundamentally from the operation of the rotors in a planetary rotor (orbital) hydraulic motor. It is not necessary to create a rotating hydraulic field of the working fluid to enable the operation of the gerotor pump.

A 3D model of the orbital gerotor hydraulic motor is reported in [16]. It takes into account a dynamically changing working fluid volume in the working chambers. An algorithm for the deformation of grid in the CFD software package was proposed. However, no issues related to the working fluid flow in the flow-through parts of the distribution systems were addressed.

Thus, the relationship between the structural parameters of elements in a distribution system and the output characteristics of the planetary hydraulic motor has remained insufficiently studied up to now. Investigating a given issue would make it possible to solve a scientific problem related to the improvement of output characteristics of the planetary hydraulic motor, by improving parameters of the flow-through parts of its distribution system.

---

## 3. The aim and objectives of the study

---

The aim of present study is to substantiate structural parameters of the flow-through parts in a distribution system in order to improve the output characteristics of the planetary hydraulic motor.

To accomplish the aim, the following tasks have been set:

- to develop a design diagram and propose a mathematical apparatus that would make it possible to examine the influence of structural parameters of the distribution system on output characteristics of the planetary hydraulic motor;
- to explore and substantiate rational kinematic diagrams of the distribution system. That would enable the improvement of output characteristics of the planetary hydraulic motor;
- to construct an algorithm for designing the flow-through parts that would employ rational kinematic diagrams of the distribution system in a planetary hydraulic motor.

**4. Materials and methods for designing a distribution system of the planetary hydraulic motor**

One of the basic nodes, which limits the work of a planetary hydraulic motor, is the working fluid distribution system. A distribution system is designed to feed the fluid into the working chambers of the hydraulic motor in a strictly defined sequence [1, 2, 9, 17, 18].

A distribution system of a planetary hydraulic motor consists of two elements. They are a stationary sleeve valve (Fig. 1, *a*) and a movable distributor (Fig. 1, *b*).

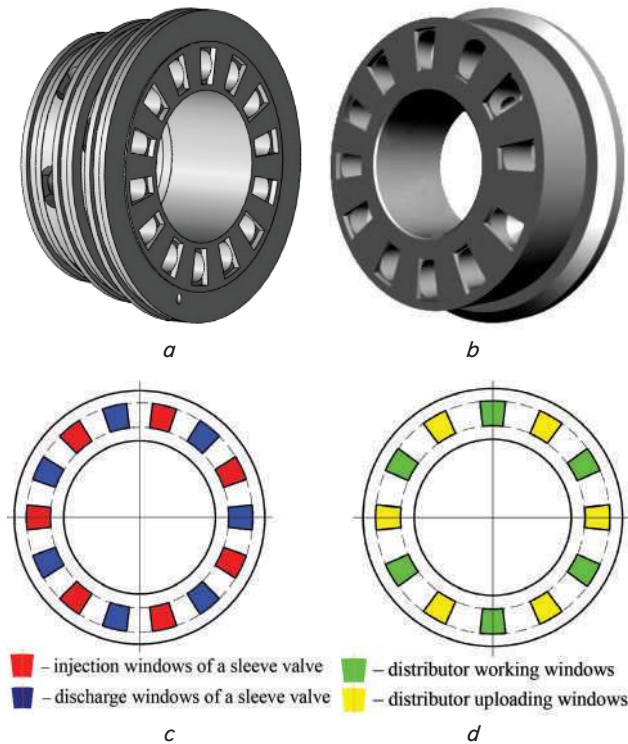

Fig. 1. Elements of a distribution system: *a* is a sleeve valve, *b* is a distributor, *c* is an end surface of a sleeve valve; *d* is an end surface of a distributor

The end surface of the sleeve valve is a ring, which has symmetrically located distributing windows for the injection and discharge of the working fluid, (Fig. 1, *c*). The end surface of the distributor, which has the form of a ring as well, is equipped with the distributing windows – working and uploading (Fig. 1, *d*). Distributing windows of the sleeve valve and the distributor are shaped in the form of a segment. It is optimal for a given type of the distribution system [9, 17]. During operation of the distribution system of the planetary hydraulic motor, the end surfaces of the sleeve valve and the distributor are in constant contact; forming a zone of distribution. Working windows of the distributor are used for the distribution of the working fluid, the discharging ones – for balancing. The number of control valve injection windows, related to the number of working windows of the distributor defines the ordinal number of the kinematic diagram for the distribution system of a planetary hydraulic motor.

Inside the sleeve valve and the distributor, there are the channels of complex configuration. The channels together with the injection and discharge windows of the sleeve valve, as well as with the working windows of the distributor, form

the flow-through parts of the distribution system. The main characteristic of the flow-through parts in the distribution system of the planetary hydraulic motor is the flow section area of distribution windows, which are located in the zone of distribution. This characterizes the throughput capacity of the distribution system in general.

To determine the relationship between geometrical parameters of the flow-through parts of the distribution zone and the distribution system flow section, we developed a design diagram for the zone of the flow-through parts distribution in the distribution system (Fig. 2).

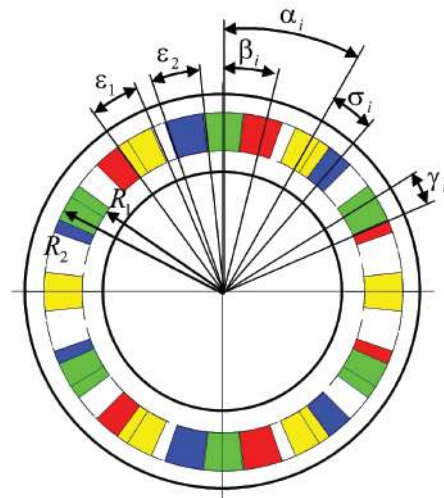

Fig. 2. A design diagram of the distribution zone of the distribution system flow-through parts:  $\alpha_i$  is a location angle of the distributor windows;  $\beta_i$  is a sleeve valve windows location angle;  $\epsilon_1$  is an opening angle of the distributor windows;  $\epsilon_2$  is an opening angle of the sleeve valve windows;  $\sigma_i$  is an angle between the centers of the distributor windows and the sleeve valve windows, which are overlapped;  $\gamma_i$  is an angle of the overlap between the sleeve valve windows and the distributor windows;  $R_1$  and  $R_2$  are the inner and outer radii of the distributing windows location

The number of windows (Fig. 2) in the distributor  $Z_1$  and the sleeve valve  $Z_2$  is interrelated by dependence  $Z_1 = Z_2 - 2$ . Geometrical shapes of the ring surface of the distributor and the sleeve valve are set by the inner  $R_1$  and outer  $R_2$  radii [9]. The angle between the working windows of the distributor in a static position is equal to  $\alpha = 2\pi/Z_1$ , and the angle between the windows of the sleeve valve is  $\beta = 2\pi/Z_2$ .

The location angle of the first window of the sleeve valve  $\beta_1$  is derived from expression:

$$\beta_1 = \frac{\pi}{Z_2}, \tag{1}$$

and the location angles of the following windows in the sleeve valve will be equal to:

$$\beta_2 = \beta_1 + \beta, \dots, \beta_i = \beta_{i-1} + \beta, \tag{2}$$

where  $\beta_1, \beta_3, \dots, \beta_i$  are the injection windows (odd);  $\beta_2, \beta_4, \dots, \beta_i$  are the discharge windows of the sleeve valve (even).

The location angle of the first working window in the distributor  $\alpha_1$  is derived from expression:

$$\alpha_1(t) = \int \omega_{h,m} dt, \tag{3}$$

and location angles of the following windows in a distributor will be equal to:

$$\alpha_2(t) = \alpha_1(t) + \alpha, \dots, \alpha_i(t) = \alpha_{i-1}(t) + \alpha. \tag{4}$$

where  $\alpha_1, \alpha_3, \dots, \alpha_i$  are the working windows (odd);  $\alpha_2, \alpha_4, \dots, \alpha_i$  are the discharge windows in the distributor (even).

Thus, the current angle between the centers of the distributor and the sleeve valve windows, which are located in the overlap, will be equal to:

$$\sigma_i(t) = |\beta_i - \alpha_i(t)|. \tag{5}$$

In this case, the condition  $\sigma_i \leq \beta/2$  must be satisfied for the windows to overlap. The angle, which limits geometrical parameters of distributing windows, is equal to:

$$\varepsilon = \frac{\pi}{Z_2}. \tag{6}$$

It is known from [9, 17] that the distribution system with the same geometrical parameters of the distributor windows  $\varepsilon_1$  and the sleeve valve windows  $\varepsilon_2$  when  $\varepsilon = \varepsilon_1 = \varepsilon_2$ , has the greatest throughput capacity.

As we know the angle, which limits geometrical parameters of the distributing windows, we shall determine the overlapping angle between the windows of the sleeve valve and the windows of the distributor:

$$\gamma_i(t) = \varepsilon - \sigma_i(t). \tag{7}$$

If the current angle between the centers of the distributor windows and the sleeve valve windows, located in the overlap, is equal to zero, i. e.  $\sigma_i = 0$ , the distributor window completely overlaps the sleeve valve window and the overlapping angle is equal to the opening angle of window  $\gamma_i = \varepsilon$ .

An area of the flow section in a distribution system depends on the area of overlapping between windows of the distributor and control valve with respect to their relative position. Depending on the rotation angle of the hydraulic motor shaft the area of overlapping between the  $i$ -th window of the distributor and injection windows of control valve is described by the following dependence:

$$S_i(t) = \sum_{i=1}^Z \left( \frac{\pi}{Z_2} - |\beta_i - \alpha_i(t)| \right) \cdot \frac{(R_2^2 - R_1^2)}{2}, \tag{8}$$

provided condition  $\alpha_1(t) \leq 2\pi$  is satisfied; if  $\alpha_1(t) > 2\pi$ , then  $\alpha_1(t) = \alpha_1(t) - 2\pi$ .

For the following windows of the distributor, the overlapping is determined by analogy. The total area of the overlap, which is the area of the flow section of the distribution system, will be equal to:

$$S_{f,s} = \sum_{i=1}^Z S_i(t).$$

The flow rate of fluid  $v$  in distributing windows is derived from expression  $Q = S_{f,s} \cdot v$  according to [9, 17]:

$$v = \sqrt{\frac{2\Delta p}{\rho}}, \tag{9}$$

where  $\Delta p$  is the pressure drop of the working fluid;  $\rho$  is the density of the working fluid.

Taking into account the expression (9), the flow rate will be derived from formula:

$$Q = \mu \cdot S_{f,s} \cdot \sqrt{\frac{2\Delta p}{\rho}}. \tag{10}$$

Substituting expression (8) into expression (10), we obtain a theoretical working fluid flow rate in the distribution system:

$$Q = \mu \cdot \sum_{i=1}^Z \left[ \frac{\pi}{Z_2} - |\beta_i - \alpha_i(t)| \right] \cdot \frac{(R_2^2 - R_1^2)}{2} \cdot \sqrt{\frac{2\Delta p}{\rho}}. \tag{11}$$

It was established [9, 13] that the main source of pulsations in the flow-through parts of the distribution system is a distribution zone formed by the end surfaces of the sleeve valve and the distributor. The change in the area of the flow section of the distribution system depends on the number of the distributing windows and affects the shape and actual magnitude of the pulsations.

The proposed mathematical dependences, which describe changes in the amount of working fluid, that passes through the distribution system, makes it possible to examine the influence of the change in the flow section on the output characteristics of the planetary hydraulic motor.

Influence of the structural parameters of the distribution system and the working fluid pulsation on the output characteristics of the planetary hydraulic motor was investigated with the help of the parametric modeling of the distribution system operation under running conditions of the planetary hydraulic motor.

To model the distribution system operation, we adopt the following initial data and initial conditions (using the PRG-22 series planetary motor as an example):

- An angular velocity of the hydraulic motor shaft is  $\omega = 68 \text{ s}^{-1}$ ;
- The angles, which limit the geometrical parameter of the distributor  $\varepsilon_1$  and the sleeve valve  $\varepsilon_2$ , are equal, i. e.  $\varepsilon = \varepsilon_1 = \varepsilon_2$ ;
- The inner radius of the distributing windows location is  $R_1 = 29 \text{ mm}$ ;
- The outer radius of the distributing windows location is  $R_2 = 43 \text{ mm}$ .

### 5. Analysis of results of studying the structural parameters of flow-through parts of the distribution system

A kinematic circuit of the distribution system is chosen depending on the functional purpose of the designed planetary hydraulic motor. These circuits characterize the synchronicity of hydraulic field rotation with working elements of the hydraulic motor.

While studying changes in the total area of flow section of the distribution system depending on a kinematic circuit (Fig. 3), it was established that the increase in the number of distributing windows leads to an increase in the area of flow section of the distribution system. However, using the 14/13 kinematic circuits, and larger, is impractical because the throughput capacity of the distribution system in general decreases.

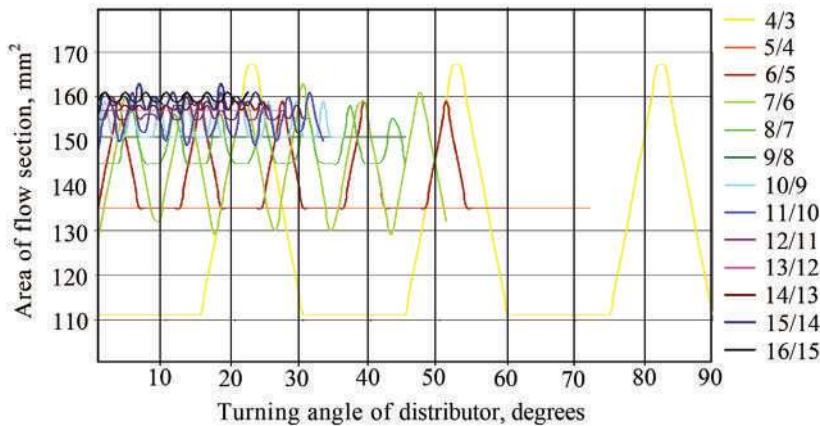

Fig. 3. Change in the total area of flow section of distribution systems for different kinematic circuits

When analyzing the derived dependence (Fig. 3) one can conclude that the change in the total area of flow section for kinematic circuits from 4/3 to 13/12 can be represented by three dependences (Fig. 4).

For kinematic circuits 4/3; 6/5; 8/7; 10/9; and 12/11, a change in the total areas of flow section of distribution systems (Fig. 4, a) is cyclical. Depending on the kinematic circuit, fluctuations in the area of flow section in the injection and discharge zones vary in counter phase.

The dependence of change in the total areas of flow section of distribution systems for kinematic circuits 7/6 and 11/10 is a broken (sawtooth) curve) (Fig. 4, c). The curves of the total areas of flow section of the injection and discharge zones vary synchronously (in phase).

Operation of the distribution system in a hydraulic motor without the working fluid flow pulsation is enabled by kinematic circuits 5/4; 9/8; and 13/12. Dependences of change in the total areas of flow section for these kinematic circuits are represented by a straight line (Fig. 4, b).

It should be noted that the increase in the total area of flow section in the distribution system can be achieved by using the discharge windows of the distributor as the working zones (Fig. 5). Angular offset of the distributor windows helps reduce the working fluid flow pulsation. A procedure for increasing the area of flow section and reducing the working fluid flow pulsation via angular shift of windows of the distribution system is described in detail in paper [9].

We shall consider operation of the distribution system using the discharge windows of the distributor as the working windows.

Initially, the distributor and control valve are positioned (Fig. 5) such that to the right are the distributor working windows, overlapping injection windows 3 of control valve – an injection zone, while to the left are the distributor working windows, overlapping discharge windows 4 of control valve – a discharge zone.

It is possible to improve throughput capacity of the distribution system by combining the discharge windows and the respective working chambers (Fig. 5) using additional flow-through parts. To this end, additional screw channels (Fig. 6, a) are cut at the outer surface of the shaft conjugated with the distributor, and additional drilling is performed at the inner surface of the distributor conjugated with the shaft (Fig. 6, b). The flow-through parts obtained, formed by the discharge windows of the distributor, additional drilling, and screw channels, make it possible to feed the fluid to the hydraulic motor's working chambers. The number of screw channels is defined based on the kinematic circuit of the distribution system [9].

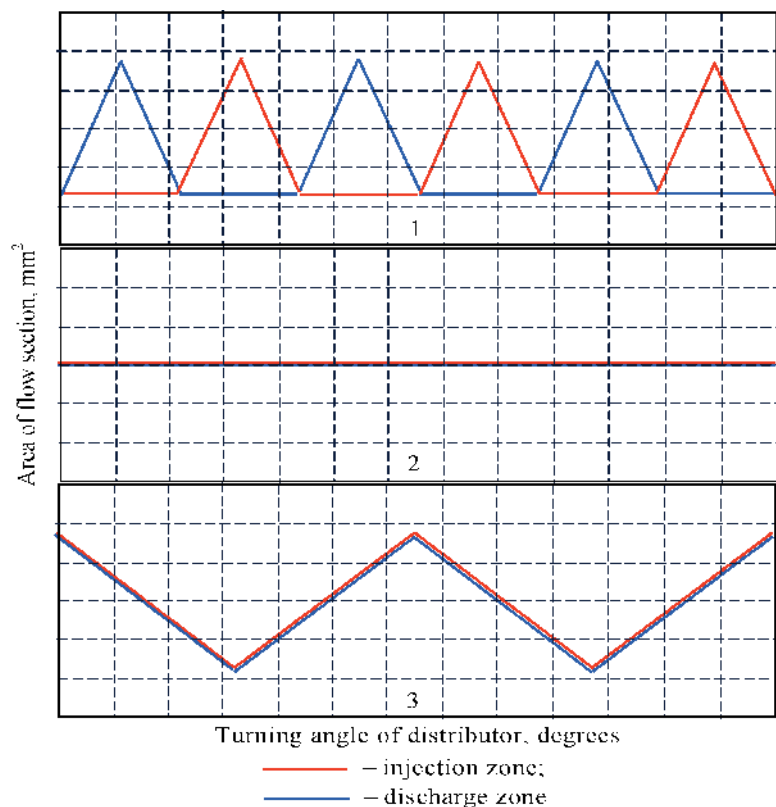

Fig. 4. Change in the total areas of flow section of distribution systems for different kinematic circuits: 1 – 4/3; 6/5; 8/7; 10/9; 12/11; 2 – 5/4; 9/8; 13/12; 3 – 7/6; 11/10

To study the passage of working fluid through flow-through parts of the distribution system, it is required to consider the movement of working fluid along channels and openings in the distributor and control valve, as well as in the distributing zone formed by the distributing windows.

Fig. 7 shows types of channels of flow-through parts implemented in the control valve and distributor.

In order to improve output characteristics of the planetary hydraulic motor, it is necessary to identify formation zones of hydraulic losses, due to local resistance when

a working fluid passes flow-through parts of the distribution system. To this end, we created images of flow-through parts in the control valve (Fig. 8) and distributor (Fig. 9), formed by channels and distributing windows.

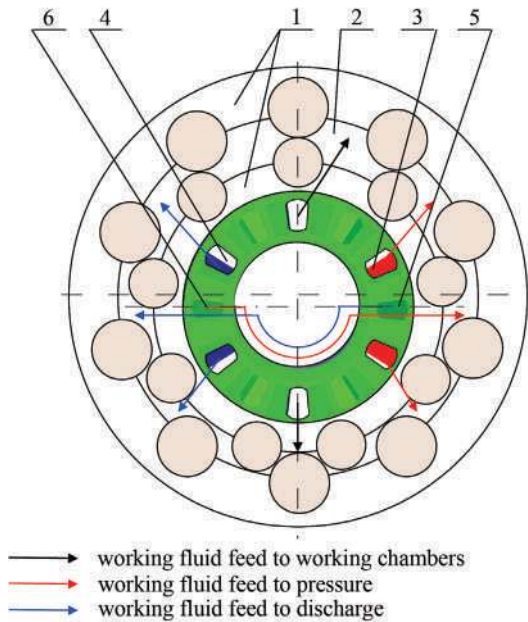

Fig. 5. Schematic of the working fluid feed to the working chambers of a hydraulic motor:  
 1 – tooth gear couple; 2 – working chambers formed by the toothed gearing; 3 – overlapping of the injection windows of control valve with the working windows of distributor; 4 – overlapping of the discharge windows of control valve with the working windows of distributor; 5 – overlapping of the discharge windows of control valve with the discharge windows of distributor; 6 – overlapping of the injection windows of control valve with the discharge windows of distributor

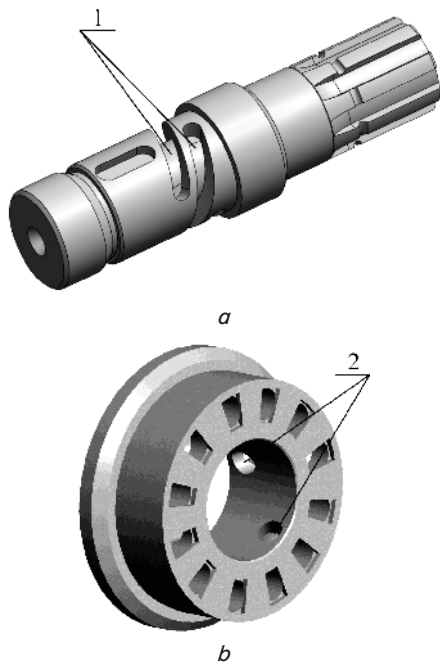

Fig. 6. Additional elements of distribution system:  
 a – on the shaft; b – on the distributor

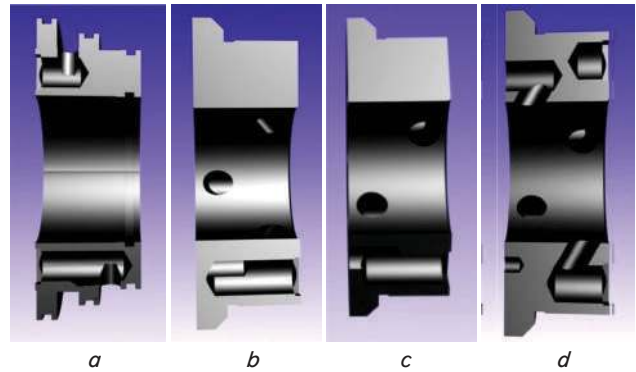

Fig. 7. Channels along which working fluid moves:  
 a – in control valve; b, c, d – in the distributor

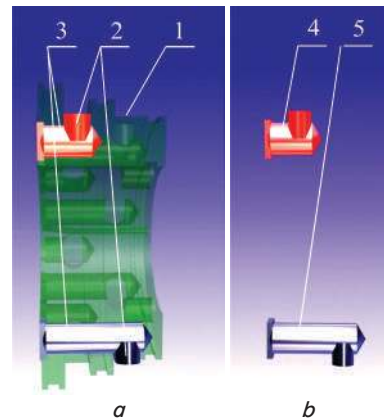

Fig. 8. Flow-through parts of control valve:  
 a – channels; b – images of flow-through parts; 1 – circular channel; 2 – radial channel; 3 – end side channel; 4 – injection zone; 5 – discharge zone

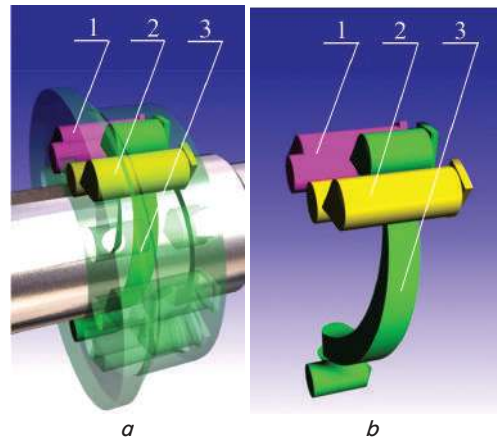

Fig. 9. Flow-through parts of distributor:  
 a – channels; b – images of flow-through parts; 1 – channel, shown in Fig. 7, b; 2 – channel, shown in Fig. 7, c; 3 – channel, shown in Fig. 7, d

Flow-through parts of control valve are formed (Fig. 8, a) by circular channel 1, radial 2, and end-side 3, which are conjugated with an end side surface of the distributor [18]. Images of flow-through parts of control valve are represented (Fig. 8, b) by injection zone 5 and discharge zone 6.

Flow-through parts of distributor are formed by channels 1, 2, and 3 (Fig. 9, a), along which a working fluid is

fed into working chambers. Images of flow-through parts of distributor are represented (Fig. 9, *b*) by three types of channels of different configuration. Flow-through parts 1 and 2 are identical (in terms of the formation of local resistances), which is why we considered only one of the channels in our study. Flow-through part 3 is a complex configuration and consists of channels in a variety of shapes and cross-sections.

To visualize the displacement process of a working fluid along channels and distributing openings we developed a relationship scheme (Fig. 10) between conjugating elements of flow-through parts in the distribution system.

The proposed scheme makes it possible to implement visual simulation of the fluid flow in the sequentially connected parts of control valve 1 and distributor 4 using any software package capable of solving the set problem.

It was accepted in the course of modeling that fluid arrives through flow-through parts of channel 2 in control valve 1 to windows 3, located at its side surface. Windows 3 are in contact with windows 6 at the end-side surface of distributor 4. Fluid enters working chambers of hydraulic motor along flow-through parts of channels 5 in distributor 4.

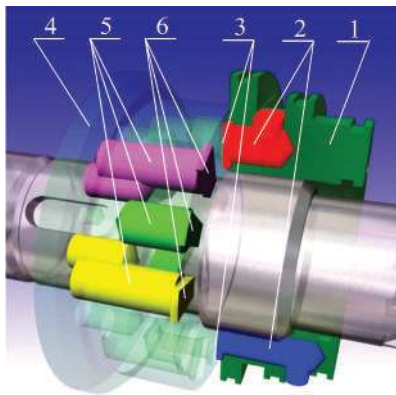

Fig. 10. Relation scheme between elements of flow-through parts of the distribution system:

- 1 – control valve; 2 – images of channels of flow-through parts in control valve; 3 – images of injection and discharge windows of control valve; 4 – distributor; 5 – images of channels of flow-through parts in distributor; 6 – images of working and discharge windows in distributor

We simulated the flow of a working fluid along flow-through parts of the distribution system using the universal software package for a finite element analysis Ansys.

An analysis of simulation results shows (Fig. 11) that pressure in the control valve channel in an injection zone (Fig. 11, *a*) is 19.9 MPa; in the distributor channels – 17.7 MPa [18]. Working fluid pressure in the contact area of distributing windows at their partial overlap is 19.25 MPa; pressure at the inlet to the working chamber is 17.7 MPa.

Pressure in the distributor channel for the discharge line is 4 MPa (Fig. 11, *b*), for control valve – 3 MPa. Pressure in the contact area between distributing windows at their full overlap is 3.6 MPa. An analysis of change in the fluid pressure shows (Fig. 12) that in the injection zone (Fig. 12, *a*) in the control valve channel the pressure is 19.9 MPa; in the channel of distributor – 19.4 MPa, and in a screw groove – 19.6 MPa. Working fluid pressure in the contact area between distributing windows at their full overlap is 19.8 MPa; pressure at the inlet to the working chamber is 19.3 MPa.

For the discharge line, pressure of the working fluid at the outlet from the working chamber is 4 MPa (Fig. 12, *b*). Pressure in the distributor channel varies from 4 MPa to 3.995 MPa, along the screw groove – from 3.995 to 3.988 MPa; in the control valve channel, it is 3.97 MPa. Working fluid pressure in the contact area between distributing windows at their full overlap is 3.985 MPa.

Working fluid flow rate in an injection line (Fig. 13, *a*) in the channels of control valve and distributor is about 15 m/s; in the contact zone between distributing windows at their partial overlap, it is 45 m/s. For the discharge line, the working fluid flow rate (Fig. 13, *b*) in the channels of distributor and control valve at fully overlapped distributing windows is 9 m/s.

For the injection line, the working fluid flow rate (Fig. 14, *a*) in the channels of control valve is 7 m/s, of distributor – 20 m/s; in the process of moving along a screw groove, implemented on the hydraulic motor shaft, varies from 20 m/s to 7 m/s. Working fluid velocity in the contact zone between distributing windows at full overlap is about 10 m/s, and when it arrives into the working chamber, it is 13 m/s. The working fluid flow rate in the discharge line (Fig. 14, *b*) at the outlet from the working chamber is 0.9 m/s; in the channels of distributor – 1.8 m/s, along a screw groove – 2.5 m/s, in the channels of control valve – 1.5 m/s. In the contact zone between distributing windows at full overlap, the speed is 2.7 m/s.

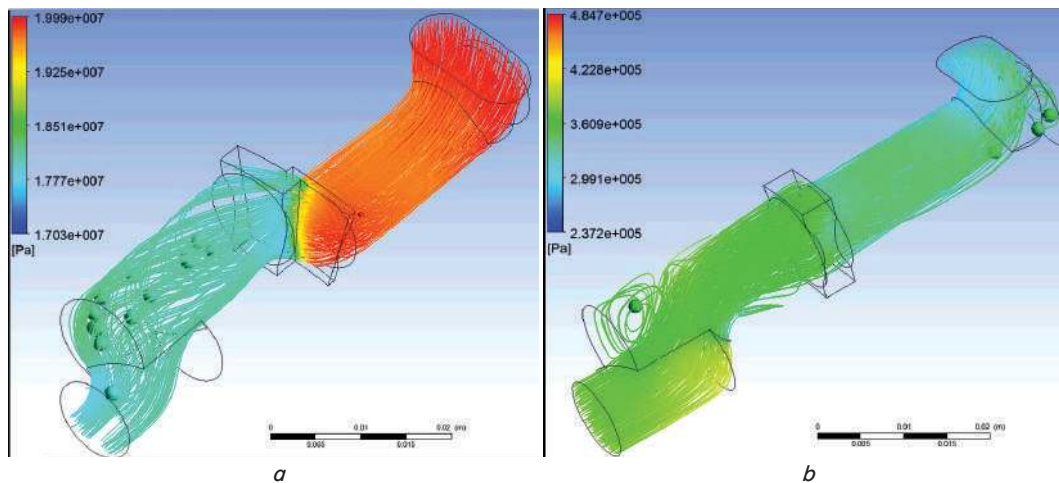

Fig. 11. Change in the working fluid pressure along control valve channels and distributor channels (channels of type 1, 2 (Fig. 9): *a* – at injection; *b* – at a discharge of working fluid

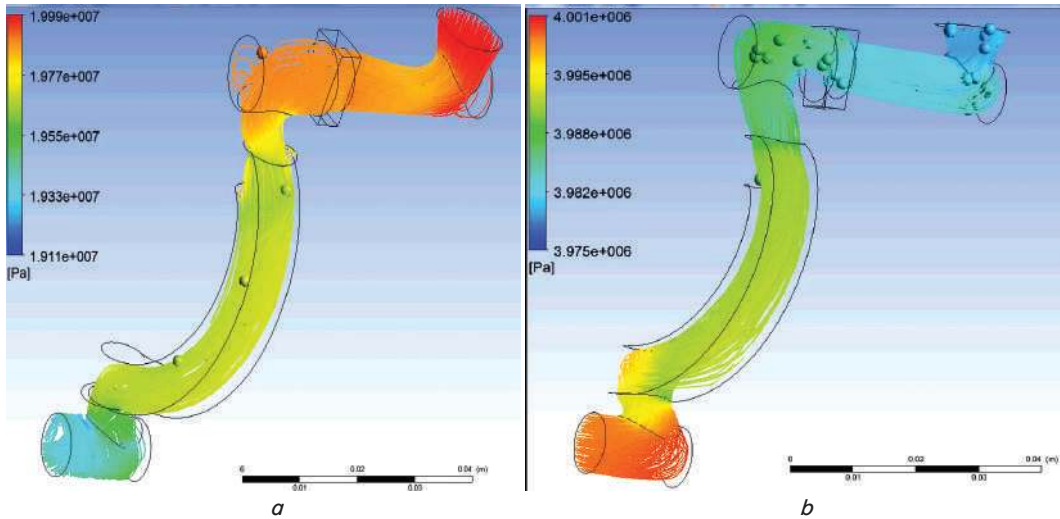

Fig. 12. Change in the working fluid pressure in the channels of control valve and distributor (channel of type 3 (Fig. 9)): *a* – at injection; *b* – at a discharge of working fluid

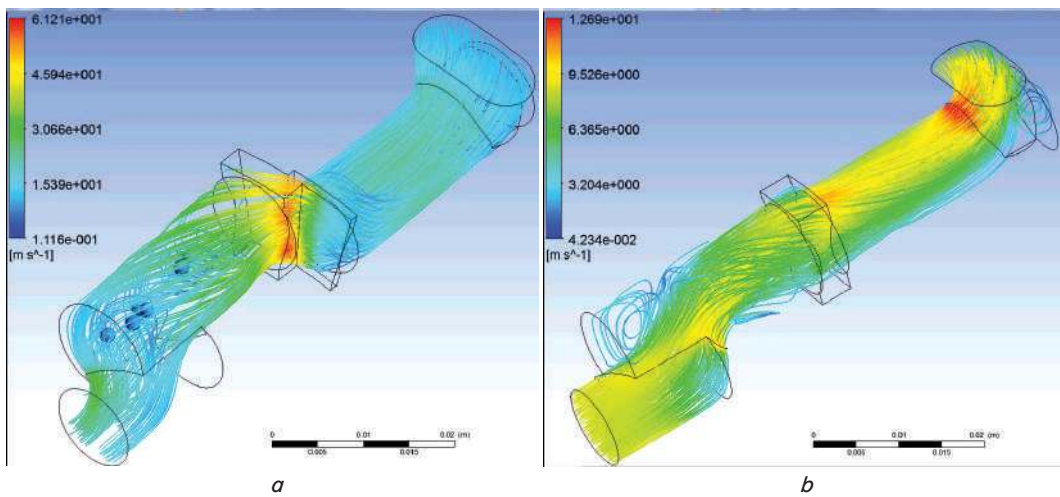

Fig. 13. Change in the working fluid flow rate in the channels of control valve and distributor (type 1, 2 channels (Fig. 9)): *a* – at injection; *b* – at a discharge of working fluid

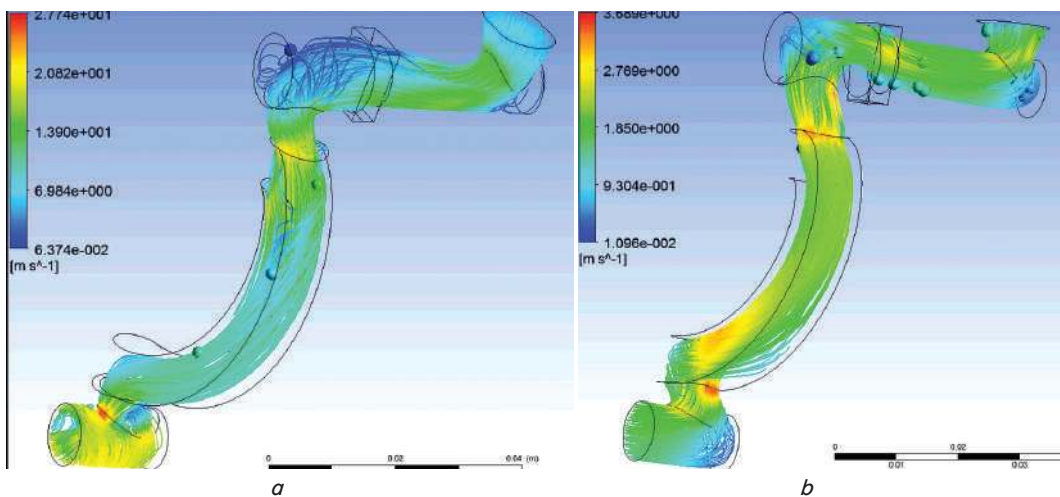

Fig. 14. Change in the working fluid flow rate in the channels of control valve and distributor (type 3 channel (Fig. 9)): *a* – at injection; *b* – at a discharge of working fluid

The study conducted has allowed us to identify a formation zone of hydraulic losses caused by local resistances, when working fluid passes through distributing windows of control

valve and distributor – to the distribution zone (Fig. 11). The fluid flow along flow-through parts of channels with complex configuration (channel of type 3, Fig. 9), formed



when using discharge windows of distributor as additional ones, does not cause significant hydraulic losses (Fig. 12, 14).

When designing planetary hydraulic motors of the PRG series (currently manufactured industrially), they used the proposed algorithm for designing flow-through parts of the distribution systems. Given the structural features of a hydraulic motor of the PRG series, a kinematic circuit of the 7/6 distribution system is employed. When designing flow-through parts of the distribution system, two options for using additional flow-through parts were considered – with two and three discharge windows.

Because the critical region in designing the flow-through parts is the distribution zone, further study implied determining a change in the total flow section of the distribution system.

Analysis of dependence (Fig. 15) shows that the area of the flow section without the use of discharge windows varies from 150 mm<sup>2</sup> to 190 mm<sup>2</sup>, with a fluctuation amplitude of 40 mm<sup>2</sup>. Area fluctuations cause the pulsation of a working fluid flow, producing a negative effect on the operation of a planetary hydraulic motor.

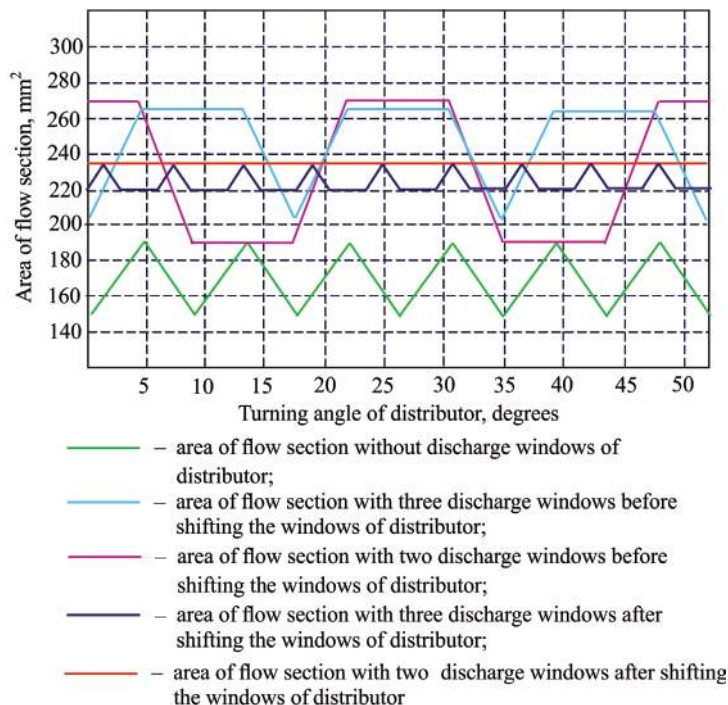

Fig. 15. Dependence of change in the total area of flow section of the distribution system on turning angle of the planetary hydraulic motor shaft

Analysis of change in the area of flow section in the PRG series hydraulic motor distribution system using three discharge windows, revealed that the area of the flow section had increased. In this case, the area changes from 200 mm<sup>2</sup> to 268 mm<sup>2</sup>, with a fluctuation amplitude of 68 mm<sup>2</sup> (Fig. 15). The result of shifting the windows [9] is the changes in the area of flow section, which equal 220...236 mm<sup>2</sup> at an amplitude of 16 mm<sup>2</sup>.

When using a distribution system with two discharge windows, after shifting the windows of distributor, the area of flow section reached 236 mm<sup>2</sup> (Fig. 15) without the working fluid flow pulsations.

The study we conducted indicates that the use of discharge windows of distributor as working windows makes it possible to apply different kinematic circuits of distribution systems, depending on the structural characteristics of the hydraulic motor.

## 6. Discussion of the results of investigating the structural parameters of the flow-through parts in the distribution system

We have developed a design diagram and proposed a mathematical apparatus, which make it possible to examine the influence of the structural parameters of the distribution system on the output characteristics of a planetary hydraulic motor. A special feature of the design diagram is the possibility of its application when designing end-side distribution systems for hydraulic machines of the volumetric type regardless of the number of distributing windows and kinematic diagram of the distribution system.

The proposed mathematical apparatus enables to determine the total area of the flow section in the flow-through parts of the distribution zone, as well as the flow rate of the working fluid in this zone.

In the course of our study we identified the zone of maximum hydraulic losses formation. It is a distribution zone (Fig. 11). We also established that the use of channels with a complex configuration in the flow-through parts does not cause significant hydraulic losses (Fig. 12, 14). This is explained by that the fluid losses due to friction against walls of the channels remain almost unchanged when the fluid moves along the channels with the predefined section. In the distribution zone, the flow section of the overlapping windows is constantly changing from zero to maximum. Therefore, hydraulic losses will be maximized. That is why, when designing the flow-through parts for the distribution systems, special attention is paid to the formation of a distribution zone, which is created by the end surfaces of the sleeve valve and the distributor. The zone forms maximum local losses. When using distributing windows with a different configuration (round, oval, etc.), expression (8) for determining the area of the overlap needs to be modified depending on the geometry of the windows under consideration.

The algorithm, which we have developed, helped determine the sequence of stages when designing the distribution systems of hydraulic machines. It enables:

- to choose a kinematic diagram for a distribution system according to the results of the current study (Fig. 3, 4);
  - to define the need to use discharge windows in the distributor as the working windows according to the design features of the hydraulic machine. This could be explained by the use of the discharge windows, which can increase the area of the flow section of the distribution system flow-through parts in the distribution zone;
  - to calculate the change in the angular arrangement of the distributing windows based on the existing procedure in order to eliminate pulsations when it is necessary [9].
- The proposed algorithm for designing the flow-through parts could be used when developing end-side distribution systems for various hydraulic machines, which exploit

a volumetric principle of operation. The procedure, which we have considered, makes it possible to determine hydraulic losses in the flow-through parts of the channels in the distribution system. For this purpose, the universal *Ansys* software package for a finite element analysis can be used.

The restriction of current study as we see it is its limited application. It is appropriate only for hydraulic machines with an end-side working fluid distribution. Therefore, further research should consider the adaptation of the proposed procedure to other types of distribution systems (direct, sleeve valve, etc.).

---

## 7. Conclusions

---

1. The design diagram developed, and the mathematical apparatus proposed, allow us to explore the influence of the structural parameters of the distribution system on the output characteristics of the planetary hydraulic motor. A special feature of the devised design diagram is a possibility of its application when designing end-side distribution systems for hydraulic machines based on a volumetric action regardless of the number of the distributing windows and the kinematic diagram of the distribution system. The proposed mathematical apparatus makes it possible to determine the total area of the flow section for the flow-through parts and the working fluid flow rate in the distribution zone.

2. The study we conducted has helped identify dependences of the change in the flow section area of the distribution system on a kinematic diagram. It was established that the increase in the number of distributing windows leads to the increase in the flow section area. It should be noted that the total area of the flow section in distribution systems

for 4/3 to 13/12 kinematic diagrams changes according to three dependences:

– for 4/3; 6/5; 8/7; 10/9; 12/11 diagrams: dependences are of non-synchronous cyclical character and they change in antiphase;

– for 7/6; 11/10 diagrams: dependences are of synchronous cyclical character and they change in phase;

– for 5/4; 9/8; 13/12 diagrams: dependences are represented by a straight line.

The study identified a zone where hydraulic losses, caused by local resistances, form when a working fluid passes along the distributing windows of the sleeve valve and the distributor – a distribution zone. Studying the fluid flow along the flow-through parts of channels with a complex configuration, formed when using the discharge windows of the distributor, does not lead to significant hydraulic losses.

Research into changes in the output characteristics of the planetary hydraulic motors of the PRG-22 series with a 7/6 kinematic diagram, which employ two and three discharge windows, showed that:

– when using three discharge windows, the area of the flow section changes from 220 mm<sup>2</sup> up to 236 mm<sup>2</sup> at an amplitude of 16 mm<sup>2</sup>;

– when using two discharge windows, the area of flow section is 236 mm<sup>2</sup> without the working fluid flow pulsations.

3. The proposed algorithm, which defines the sequence of stages for designing the flow-through parts, makes it possible to improve the output characteristics of the planetary hydraulic motor by applying rational kinematic diagrams for the distribution system. Employing the procedure considered enables determining hydraulic losses in the flow-through parts of the distribution system channels with the help of using the universal software systems.

---

## References

1. Voloshina A. A. Design features of planetary type hydromachines used in the hydraulic units of mobile machines // Scientific Bulletin of the Tavria State Agrotechnological University. 2013. Vol. 1, Issue 3. P. 65–86. URL: <http://nauka.tsatu.edu.ua/e-journals-tdata/pdf3t1/13vaaumm.pdf>
2. Panchenko A. I., Voloshina A. A., Panchenko I. A. Development of planetary hydraulic motors for the power hydraulic drives of mobile machinery // MOTROL. 2015. Vol. 17, Issue 9. P. 29–36.
3. Stryczek J., Bednarczyk S., Biernacki K. Strength analysis of the polyoxymethylene cycloidal gears of the gerotor pump // Archives of Civil and Mechanical Engineering. 2014. Vol. 14, Issue 4. P. 647–660. doi: 10.1016/j.acme.2013.12.005
4. Development of an Integrated System for the Automated Design of a Gerotor Oil Pump / Chang Y. J., Kim J. H., Jeon C. H., Kim C., Jung S. Y. // Journal of Mechanical Design. 2007. Vol. 129, Issue 10. P. 1099. doi: 10.1115/1.2757629
5. Design of Rotor for Internal Gear Pump Using Cycloid and Circular-Arc Curves / Choi T. H., Kim M. S., Lee G. S., Jung S. Y., Bae J. H., Kim C. // Journal of Mechanical Design. 2012. Vol. 134, Issue 1. P. 011005. doi: 10.1115/1.4004423
6. Stryczek J., Bednarczyk S., Biernacki K. Gerotor pump with POM gears: Design, production technology, research // Archives of Civil and Mechanical Engineering. 2014. Vol. 14, Issue 3. P. 391–397. doi: 10.1016/j.acme.2013.12.008
7. Teeth Clearance and Relief Grooves Effects in a Trochoidal-Gear Pump Using New Modules of GeroLAB / Gamez-Montero P. J., Garcia-Vilchez M., Raush G., Freire J., Codina E. // Journal of Mechanical Design. 2012. Vol. 134, Issue 5. P. 054502. doi: 10.1115/1.4006440
8. A two scale mixed lubrication wearing-in model, applied to hydraulic motors / Furustig J., Almqvist A., Bates C. A., Ennemark P., Larsson R. // Tribology International. 2015. Vol. 90. P. 248–256. doi: 10.1016/j.triboint.2015.04.033
9. Panchenko A. I., Voloshina A. A. Planetary rotary hydraulic motors. Calculation and designing: monograph. Melitopol: Publishing and Printing Center «Lux», 2016. 236 p.
10. Yang D. C. H., Yan J., Tong S.-H. Flowrate Formulation of Deviation Function Based Gerotor Pumps // Journal of Mechanical Design. 2010. Vol. 132, Issue 6. P. 064503. doi: 10.1115/1.4001595

11. Marcu I. L., Pop I. I. Interconnection Possibilities for the Working Volumes of the Alternating Hydraulic Motors // Scientific Bulletin of the Politehnica University of Timisoara. Special issue: Transactions on Mechanics: The 6th International Conference on Hydraulic Machinery and Hydrodynamics. 2004. P. 365–370.
12. Velev E. Study Cavitation Gerotor Motors, Using Computer Simulatio // XV International Scientific Conference: Renewable Energies and Innovative Technologies. Smolyan. Bulgaria, 2016. P. 64–66.
13. Analysis of Forces and Moments in Gerotor Pumps / Ivanovic L., Devedzic G., Miric N., Cukovic S. // Proceedings of the Institution of Mechanical Engineers, Part C: Journal of Mechanical Engineering Science. 2010. Vol. 224, Issue 10. P. 2257–2269. doi: 10.1243/09544062jmes2041
14. Altare G., Rundo M. Computational Fluid Dynamics Analysis of Gerotor Lubricating Pumps at High-Speed: Geometric Features Influencing the Filling Capability // Journal of Fluids Engineering. 2016. Vol. 138, Issue 11. P. 111101. doi: 10.1115/1.4033675
15. Hsieh C.-F. Flow Characteristics of Gerotor Pumps With Novel Variable Clearance Designs // Journal of Fluids Engineering. 2015. Vol. 137, Issue 4. P. 041107. doi: 10.1115/1.4029274
16. Ding H., Lu X. J., Jiang B. A CFD model for orbital gerotor motor // IOP Conference Series: Earth and Environmental Science. 2012. Vol. 15, Issue 6. P. 062006. doi: 10.1088/1755-1315/15/6/062006
17. Voloshina A. A. Influence of the distributive systems constructive features on the output characteristics of the orbital hydraulic machines // Proceedings of the Tavria State Agrotechnological University. 2012. Vol. 5, Issue 12. P. 3–9.
18. Panchenko A. I., Voloshina A. A., Zasyadko A. I. Influence of design features of the end distribution system on the functional parameters of planetary hydraulic motor // Proceedings of the Tavria State Agrotechnological University. 2017. Vol. 3, Issue 17. P. 33–50.