



Detailed requirements and constraints for the control of flexibility

Hänninen, Seppo; Kyritsis, Anastasios ; Abdulhadi, Ibrahim ; Schwalbe , Roman; Strasser, Thomas; Kosmecki, Michael; Sobczak , Bogdan; Rink, Robert; Kedra, Bartosz; Wilk, Maciej

Total number of authors:
24

Publication date:
2015

Document Version
Publisher's PDF, also known as Version of record

[Link back to DTU Orbit](#)

Citation (APA):
Hänninen, S., Kyritsis, A., Abdulhadi, I., Schwalbe , R., Strasser, T., Kosmecki, M., Sobczak , B., Rink, R., Kedra, B., Wilk, M., Jankowski , R., Marinelli, M., Hu, J., Verbeeck, J., Obushevs, A., Guagliardi, A., Blank, M., Lehnhoff, S., Mayer, C., ... Evens, C. (2015). *Detailed requirements and constraints for the control of flexibility*.

General rights

Copyright and moral rights for the publications made accessible in the public portal are retained by the authors and/or other copyright owners and it is a condition of accessing publications that users recognise and abide by the legal requirements associated with these rights.

- Users may download and print one copy of any publication from the public portal for the purpose of private study or research.
- You may not further distribute the material or use it for any profit-making activity or commercial gain
- You may freely distribute the URL identifying the publication in the public portal

If you believe that this document breaches copyright please contact us providing details, and we will remove access to the work immediately and investigate your claim.

Project No. 609687
FP7-ENERGY-2013-IRP

ELECTRA

European Liaison on Electricity Committed Towards long-term Research Activities for Smart Grids

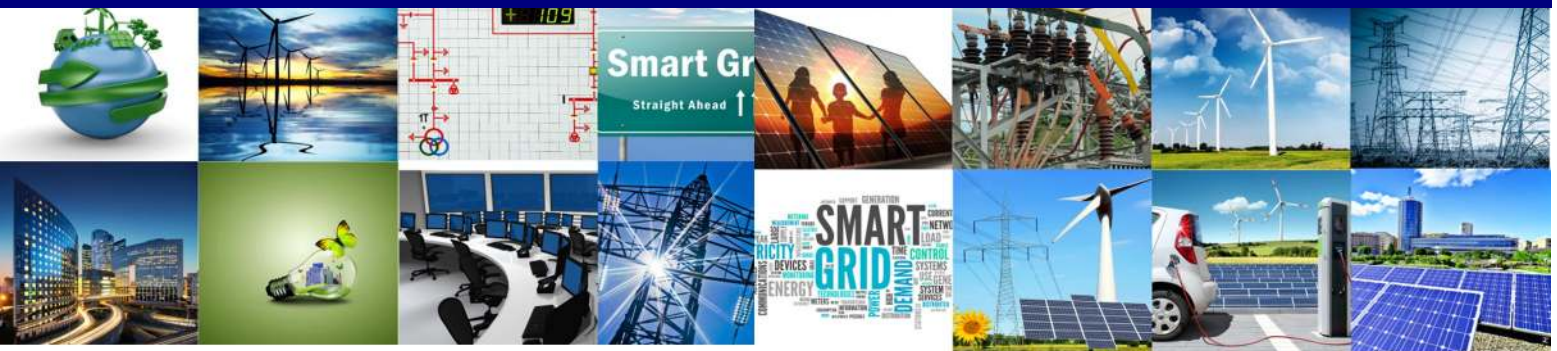

WP 6

Controllable Flexibility

Internal Report R6.1

Detailed requirements and constraints for the control of flexibility

16/01/2015

ID&Title	R6.1 Detailed requirements and constraints for the control of flexibility	Number of pages:	118
Short description (Max. 50 words):			
This Electra internal report describes the nature, availability and contribution of the flexibility resources, and identifies sources of control conflict and their extent across control boundaries. Furthermore it establishes appropriate control cycles across flexible boundaries of control through which controllers at different system levels should adhere to.			
Version	Date	Modification's nature	
V 0.01	03/10/2014	Table of content	
V 0.02	13/10/2014	First draft for Ch 3,4,5+ table of content for Ch 6	
V 0.03	03/11/2014	Updated Ch 3, 4, 5	
V 0.04	13/11/2014	Updated Ch 3, 4, 5, 6	
V 0.05	21/11/2014	Updated introduction, summary	
V 0.06	15/12/2014	WP6 internal review	
V 1.00	10/12/2014	Submitted for TOQA review	
V1.01	15/01/2015	Edited based on the comments of the quality review	
V1.02	16/01/2015	Submitted to ELECTRA Technical Committee	
Accessibility			
<input type="checkbox"/> PU, Public			
<input type="checkbox"/> PP, Restricted to other program participants (including the Commission Services)			
<input type="checkbox"/> RE, Restricted to other a group specified by the consortium (including the Commission Services)			
<input type="checkbox"/> X CO, Confidential, only for members of the consortium (including the Commission Services)			
If restricted, please specify here the group:			
Owner / Main responsible:			
WP 6 Leader:	Seppo Hänninen (VTT)		
Reviewed by:			
WP 5 Leader	Andrei Morch, SINTEF	05/01/2015	
TOQA assigned reviewer	Klaas Visscher, TNO	05/01/2015	
TOQA assigned reviewer	Carlo Tornelli, RSE	05/01/2015	
Final Approval by:			
ELECTRA Technical Committee			16/01/2015

Authors

Name	Last Name	Organization	Country
Seppo	Hänninen	VTT	FINLAND
Anastasios	Kyritsis	CRES	GREECE
Ibrahim	Abdulhadi	USTRATH	United Kingdom
Roman	Schwalbe	AIT	Austria
Thomas	Strasser	AIT	Austria
Michał	Kosmecki	IEN	Poland
Bogdan	Sobczak	IEN	Poland
Robert	Rink	IEN	Poland
Bartosz	Kedra	IEN	Poland
Maciej	Wilk	IEN	Poland
Robert	Jankowski	IEN	Poland
Mattia	Marinelli	DTU	Denmark
Junjie	Hu	DTU	Denmark
Jef	Verbeeck	VITO	Belgium
Artjoms	Obushevs	IPE	Latvia
Antonio	Guagliardi	RSE	Italy
Marita	Blank	OFFIS	Germany
Sebastian	Lehnhoff	OFFIS	Germany
Christoph	Mayer	OFFIS	Germany
Evangelos	Rikos	CRES	Greece
Fidalgo	Jose Nuno	INESC PORTO	Portugal
Abdullah	Nadar	TUBITAK	Turkey
Kari	Mäki	VTT	Finland
Corentin	Evens	VTT	Finland

Copyright

@ Copyright 2013-2016 The ELECTRA Consortium

Consisting of:

Coordinator	
Ricerca Sul Sistema Energetico – (RSE)	Italy
Participants	
Austrian Institute of Technology GmbH - (AIT)	Austria
Vlaamse Instelling Voor Technologisch Onderzoek N.V. - (VITO)	Belgium
Belgisch Laboratorium Van De Elektriciteitsindustrie - (LABORELEC)	Belgium
Danmarks Tekniske Universitet - (DTU)	Denmark
Teknologian Tutkimuskeskus - (VTT)	Finland
Commissariat A L'Energie Atomique Et Aux Energies Alternatives - (CEA)	France
Fraunhofer-Gesellschaft Zur Förderung Der Angewandten Forschung E.V – (IWES)	Germany
Centre For Renewable Energy Sources And Saving) - (CRES)	Greece
Agenzia Nazionale per Le Nuove Tecnologie, L'Energia E Lo Sviluppo Economico Sostenibile - (ENEA)	Italy
Fizikalas Energetikas Instituts - (IPE)	Latvia
SINTEF Energi AS - (SINTEF)	Norway
Instytut Energetyki - (IEN)	Poland
Instituto De Engenharia De Sistemas E Computadores Do Porto - (INESC_P)	Portugal
Fundacion Tecnalia Research & Innovation - (TECNALIA)	Spain
Joint Research Centre European Commission - (JRC)	Belgium
Nederlandse Organisatie Voor Toegepast Natuurwetenschappelijk Onderzoek – (TNO)	Netherlands
Turkiye Bilimsel Ve Teknolojik Arastirma Kurumu - (TUBITAK)	Turkey
University Of Strathclyde - (USTRATH)	UK
European Distributed Energy Resources Laboratories (DERlab)	Germany
Institute for Information Technology at University of Oldenburg (OFFIS)	Germany

This document may not be copied, reproduced, or modified in whole or in part for any purpose without written permission from the ELECTRA Consortium. In addition to such written permission to copy, reproduce, or modify this document in whole or part, an acknowledgment of the authors of the document and all applicable portions of the copyright notice must be clearly referenced.

All rights reserved.

This document may change without notice.

Executive summary

This Electra internal report includes the work of Task T6.1 describing the nature, availability and contribution of flexibility resources. This task also models the interactions across control boundaries and identifies sources of control conflicts, giving also an overview of experiences from the ELECTRA partners regarding the realization of controllers in demonstration and field test projects. The work was carried out during the period from May to December 2014.

The different type of flexibility resources, their characteristics, affecting market mechanisms and potential for aggregation were researched using a survey among project partners. The parameters used to characterise flexibility include the amount of power modulation, the duration, the rate of change, the response time, the location, the availability, the controllability, etc. Views were also received how these parameters will develop until 2030 and what are the general trends for development of amount and controllability of this resource types. The parameters characterising different energy resources provide the technical requirements for their applicability to flexible operation of the grid and their suitability for frequency and voltage control now and in the future. Regarding the flexibility of electricity generation, gas turbines and other heat motors as reciprocating engines can be started quickest. The speed of power change is clearly the highest for heat motors and their minimum power is low. Also steam and combined heat and power plants can be utilised in the relatively quick increasing of the electricity generation. Slower power changes are possible also with the nuclear power but they cannot be carried out continuously. The regulation characteristics of hydro power are superb in comparison to the other electricity generation methods. Besides the sun power, wind power is increasing most quickly in the world in the coming years. The modern wind power plants are able to active and reactive power control. Storage systems can contribute to the frequency and voltage control mechanisms. Charging and discharging of the storage system at the right moments (response within milli-seconds to seconds) can help to preserve the balance between consumption and generation. Storages can also provide secondary and tertiary frequency control. Static compensation devices maintain desired voltage level by feeding the grid with necessary reactive power. FACTS devices and cross-border connections based on HVDC converter schemes can play an important role in frequency and voltage support. Demand response, including industrial loads and household devices and electric vehicles, will have great influence in flexible operation of the grid.

This report describes appropriate models that characterize the interactions across control boundaries under normal and emergency situations, introducing suitable data rates and models of use by real-time control functions. In the future power system scheme, TSOs will be able to control significantly smaller part of the generation compared to the traditional centralized configuration, and thus they will not be able any more to compensate large deviations in the power balance. Moreover, increased electricity loads and sources such as EVs and residential PV systems, will influence the balance between day-ahead production and consumption schedule and will leave energy markets with higher and less predictable need for balancing power. The actors involved in the future grid control are balance responsible Party (BRP), cell system operator (CSO), cell operational information system (COIS), distribution system operator (DSO). Their respective roles are described and these actors play roles both to technical and market operations. Considering the web of cells concept developed in this project, the generation units will be smaller and in many cases these will be renewable resources which are less suitable for frequency control [1]. For that reason a more important role for participation at the demand side will be expected for voltage and frequency control in the future. The report describes “model based interfaces”, where the flexibility

user and the flexibility contributor agree on a simplified model which describes the actual behaviour and constraints of the flexibility resource.

Main outcomes of the work are the definition of controller conflict from a flexible power system perspective, a review of state of the art in power system control conflict and an outline of the methodology for identifying these conflicts during system operation and their impact on system stability. The report summaries the main findings from the literature and from project participant's experience in terms of scenarios or examples of controller interactions resulting in conflict. A measure of controller conflict is presented for each example. This can be used as an indicator of the impact of controller conflict on system stability. Suggestions for resolving controller conflict are also presented. The report describes the methodology proposed to construct such a dynamic model for the purposes of extracting conflicting interactions of interest from the point of view frequency and voltage stability. From the voltage stability perspective there are many factors which may significantly influence the environment for voltage stability. It seems quite certain, that possible conflicts affecting voltage stability may occur mainly due to lack of proper coordination among players in the system voltage control and reactive power reserves management which are TSOs, DSOs, Generators and Aggregators. Generally the scenery foreseen for frequency, voltage and reactive power control in 2030+ is much more complicated than it is presently.

An overview of experiences from the ELECTRA partners regarding the realization of controllers in demonstration and field test projects are also provided. It summarizes best practices and lessons learned which will provide valuable inputs for the implementation of control concepts and their testing and validation. The main requirements for controllers are reliability, fault tolerance and robustness.

Terminologies

Abbreviations

AC	Automatic generation control
ACE	Area control error
aFFR	Automatic frequency restoration reserve
AGC	Automatic generation control
AS	Ancillary Services
AVR	Automatic generation control
BAS	Building automation system.
BRP	Automatic voltage regulation
CAES	Balance responsible Party
CAPEX	Capital expenditure
CHIL	Compressed air energy storage
CHP	Controller-hardware-in-the-loop testing
COIS	Combined heat and power plant
CSO	Cell operational information system
CPU	Cell system operator
CWR	Cooling water reactor
DSO	Distribution system operator
DSR	Distributed series reactor
DFIG	Double fed induction generator
DG	Distributed generation
EDSO	European distribution system operators
EERA	European energy research alliance
ELECTRA	European liaison on electricity committed towards long-term research activities for smart grids.
EMS	Energy management system
EPC	Emergency power control
EPR	European pressurised water reactor
EUDP	Energy technology development and demonstration program
EV	Electric vehicle
EVSP	Electric vehicle service provider
FACTS	Flexible alternating current transmission systems
FCR	Frequency control reserves
FCR-D	Frequency containment reserve for disturbances
FDS	FACTS device stabilizers
FO	Fleet operator
FRR	Frequency restoration reserves
FRT	Fault ride through
HPP	Hydro power plant
HV	High voltage
HVAC	High voltage alternative current
HVDC	High voltage direct current
ICT	Information and communication technology
IGBT	Insulated-gate bipolar transistor
IRP	Integrated research program
IS	Information system
JP	Joint programme
LAES	Liquid air energy storage
LCC	Line commutated converter
LFDD	Low frequency demand disconnection
mFRR	Manual frequency restoration reserve
MPPT	Maximum power point tracking

MS	Milestone
MV	Medium voltage
MVAR	Mega unit of reactive power in electrical engineering
MW	Mega watt
NaS	Sodium sulphur
NiMH	Nickel metal hydride
NVR	National voltage regulator
OPF	Optimal power flow
PbA	Lead (Pb) acid
PCC	Point of common coupling
PHES	Pumped hydro energy storage
PHEV	Plugin hybrid electric vehicle
PHS	Pumped hydro storage
PID	Proportional integral derivative
PLL	Phase locked loop
PP	Power plant
PQR	Reactive power (Q) regulator
PSS	Power system stabilizer
PST	Phase shifting transformers
PV	Photovoltaic
PVR	Primary voltage regulation
PWM	Pulse width modulation
PWR	Pressurised water reactor
QV	Reactive power (Q) and voltage (V)
RES	Renewable energy resources
RR	Replacement reserves
RVR	Regional voltage regulator
SC	Supercapacitor
SCADA	Supervisory control and data acquisition
SFC	Secondary frequency control
SG	Smart grid
SGAM	Smart grid architecture model
SMES	Superconductive magnetic energy storage
SP	Subprogram
SPSC	Special protection and supplementary control
SSSC	Static synchronous series compensator
STATCOM	Static compensator
SVC	Secondary voltage control
SVR	Secondary voltage regulation
TCR	Thyristor controlled reactor
TSCS	Thyristor controlled series compensation
TSO	Transmission system operator
TSR	Thyristor Switched reactor (capacitor)
TFC	Tertiary frequency control
TVR	Tertiary voltage regulation
ULTC	Under load tap changing transformers
UPFC	Unified power flow controller
VAR	VAR compensator is a set of electrical devices for providing fast-acting reactive power on high-voltage electricity transmission networks
VFT	Variable frequency transformer
VPP	Virtual power plant
VR	Voltage regulator
VSC	Voltage source converter
V2H	Vehicle to home

Table of contents

1	Introduction.....	14
1.1	Scope of the report	14
1.2	Structure of the report.....	15
2	Methodology	16
3	Characterizing flexibility potential and control requirements for frequency and voltage control	18
3.1	Electricity generation.....	18
3.1.1	Hydro power	19
3.1.2	Thermal power.....	23
3.1.3	Nuclear power.....	26
3.1.4	Wind power.....	28
3.1.5	Photovoltaic.....	32
3.2	Demand response.....	33
3.2.1	Industrial loads.....	33
3.2.2	Electric vehicles (EV).....	34
3.2.3	Household appliances.....	36
3.3	Energy Storage.....	37
3.3.1	Electricity storage	38
3.3.2	Heat and cold storage.....	40
3.3.3	Pumped hydro storages (PHS)	40
3.3.4	Other types of storage	46
3.4	Other flexibility resources.....	47
3.4.1	Static compensation devices.....	47
3.4.2	Static compensators (STATCOM) and other FACTS devices	47
3.4.3	Synchronous condensers	48
3.4.4	Cross border connections	48
3.4.5	Tap changing transformers	50
3.4.6	Phase shifting transformers	52
3.4.7	Frequency transformer.....	52
4	Abstractions for modelling interactions across control boundaries	53
4.1	Identification of control boundaries within the European Electricity Networks.....	53
4.1.1	State of the Art in Frequency Control and Regulating Reserves	53
4.1.2	State of the Art in Voltage Control and regulating Reserves	56
4.1.3	Frequency and Voltage Control - the Vision of 2030	59
4.2	Interactions between actors involved in Frequency Control.....	61

4.2.1	Interactions between actors involved in Voltage Control	62
4.2.2	Primary Voltage Control.....	64
4.2.3	Secondary voltage control	65
4.2.4	Tertiary voltage control	66
4.3	Interactions modelling under normal and emergency situations	67
4.4	Model based interfaces for demand response contributors	68
4.4.1	Interface requirements for demand response.....	68
4.4.2	Model Based interfaces	69
4.4.3	Hardware abstraction.....	70
4.4.4	Flexibility categories	71
5	Modelling the conflicts across multiple control boundaries	72
5.1	Definition and causes of controller conflict	72
5.1.1	Definition of controller conflict.....	72
5.1.2	State of the art and identification of the causes of controller conflict	73
5.2	General methodology for controller conflict identification in a system with high penetration of flexibility resources	80
5.2.1	Mapping between flexibility resources.....	81
5.2.2	Development of representative control sequences.....	81
5.2.3	Identification and classification of controller conflict	81
5.3	Impact of controller conflict on frequency stability	82
5.3.1	Identification of conflict scenarios impacting frequency stability	82
5.3.2	Approaches to quantifying controller conflict impact on frequency stability.....	88
5.4	Impact of controller conflict on voltage stability	89
5.4.1	Identification of conflict scenarios impacting voltage stability	90
5.4.2	Approaches to quantifying controller conflict impact on voltage stability.....	95
6	Experiences in controller development, implementation and deployment in demonstration and field test projects.....	97
6.1	Introduction.....	97
6.2	Control algorithm definition and prototyping	97
6.2.1	Development/collection of environment/plant model	98
6.2.2	Development of controller model	98
6.2.3	Concept testing and validation	99
6.3	Controller development and implementation	99
6.3.1	Interface definition for testing environment and target environment	100
6.3.2	Development of validation scenarios and test cases	101
6.3.3	Controller development.....	101
6.3.4	Controller-Hardware-in-the-Loop testing (CHIL).....	102

6.4	Controller deployment.....	102
6.4.1	Open and closed loop operation	102
6.4.2	Acceptance test	103
6.4.3	Start of unattended operation.....	103
6.5	Validation of the developed control concept in field test	103
6.5.1	Analysis of measurement data.....	103
6.6	Experiences and lessons learned from demonstration and field test projects.....	104
6.6.1	Experiences, best practices and lessons learned.....	104
6.6.2	Important points for the ELECTRA developments.....	104
7	Conclusions	106
8	References	112
9	Disclaimer	118

List of figures and tables

Figures

Figure 1: Power ratings and discharge times required for different types of network services.....	38
Figure 2: Current framework for frequency regulation within the European Electricity Networks [65]	54
Figure 3: Traditional centralized Power system configuration with vertical control capability	55
Figure 4: General Voltage regulation scheme in nowadays large power systems.....	57
Figure 5: The bi-directional vertically and horizontally integrated power system control scheme	60
Figure 6: Future Power system configuration based on the combination cells (web of cells concept).....	60
Figure 7: The scheme of the hierarchical voltages control of a National Transmission Grid.....	63
Figure 8: Time responses in closed loop of the hierarchical voltages control of a national transmission grid.....	64
Figure 9: The AVR Controller	65
Figure 10: The Secondary Hierarchical Voltage Control Structure	66
Figure 11: Voltage controllers interaction of the HV transmission grid.....	67
Figure 12: Explanation of the model based interface for demand response contributors	69
Figure 13: Adaption of the original equations and constraints in power and energy terms .	71
Figure 14: General methodology for the identification of controller conflicts.	80
Figure 15: Design, implementation and validation process for Smart Grid systems and applications (simplified view) [110]	97
Figure 16: Example architecture for interfacing a voltage controller to operate in test environment and field [109].....	100
Figure 17: Example architecture for synchronizing several components in a co-simulation environment [110].....	101
Figure 18: Example configuration for Controller Hardware in the Loop: Coordinated Simulation of power grid, communication, with the controller operated at the field target hardware [110].....	102

Tables

Table 1: Typical hydropower size and connection to grid	19
Table 2: Some control characteristics of hydropower	20
Table 3: Power factor controllability of hydro power plants	21
Table 4: Future trends of hydro power	22
Table 5: Control characteristics of the thermal power plants.....	24
Table 6: Typical gas power plants and connections to grid and control	25
Table 7: Typical wind power size and connections to grid	29
Table 8: Output power controllability for wind power	29
Table 9: Power factor controllability for wind power.....	31
Table 10: Typical pumped hydro power size and connections to grid.....	42
Table 11: Availability of control for pumped hydro power.....	43
Table 12: Output power controllability for pumped hydro power.....	44

Table 13: Power factor controllability for pumped hydro power	46
Table 14: Summary of examples and experiences of controller conflict involving flexibility resources.....	73
Table 15: Impact of grid state on the performance of protection schemes	78
Table 16: Model components and their importance	84
Table 17: Scenario impacts on frequency stability.....	87
Table 18: Component's importance from voltage stability viewpoint	90
Table 19: Scenario impacts on voltage stability	94

1 Introduction

1.1 Scope of the report

The main objective of the work package 6 (WP6) of Electra project is to design and develop control functions for the three axes of grid operation (distributed control, vertical control, pan-European control). The main focus is in the frequency and voltage control in the transmission level but also the other control objectives in distribution level, among other reactive power, load control etc. will be taken into account in order to avoid congestions, security margins and minimising losses.

The purpose of this whole project is to research radical control solutions for the real time operation of the 2030 power system. The control solutions utilise the flexibility from across traditional boundaries (of voltage level, stakeholders, license areas, etc.) in a holistic fashion and build ubiquitous sensing and dynamic and autonomous control functions under normal and disturbed conditions.

A number of national and European projects have demonstrated the utilisation of flexibility within individual categories of grid connected devices, such as various types of domestic load, EV charging, storages, virtual power plants (VPPs) with distributed generation. This work package builds on this body of work but importantly addresses the problem more holistically. The work will consider the flexibility of different types of resources (demand, generation, storage, interconnection, network automation and network devices) and the coordinated utilisation of dispatchable resources taking account of inherent fast-acting response of other devices. The solutions exploit the design of associated flexibility in control and protection schemes in order to adapt to the changing of power system states. Such a scheme must take account of inherent dynamic response, local controls, centralised control actions, decentralised controls, and direct and price driven control mechanisms. This work will include the flexible provision of both voltage and frequency control.

Effective control and equitable distribution of rewards requires the flexibility to be measurable. Control actions must take account of the confidence bands associated with these observations. Such flexibility must be able to be exercised under emergency and restorative conditions as well as normal operating conditions. The solutions are based on the Smart Grid Architecture Model (SGAM), and they use the flexibility available at smart grid connection points and in the network provided by a diverse group of actors – individual prosumers, large generators, network operators, aggregators, suppliers. The work is also in line with the high profile of flexibility in SRA2035, especially Research area IS “Integrated truly sustainable, secure and economic electricity Systems”. This work package will develop key elements that contribute to the realisation of the new system control architectures under development within the EERA JP SG SP1. Likewise the control techniques will incorporate the flexibility available from storage resources in SP4 and interoperability issues available in SP3.

Task 6.1 is preparing for the conceptual design of the controllable flexibility by further detailing the requirements and issues as well as detailing the means such as the sources of flexibility, starting from the overall problem description worked out in WP3 (D3.1). The outcome of Task 6.1 will be documented in this internal report R6.1.

The large scale of controllable resources available at different voltage levels will play an important role in operating the network in a more flexible manner. These ‘flexibility resources’ are to be used to overcome constraints and increase network reliability and security. At the same time flexibility resources available at the consumer level can be integrated in the network through a market mechanism. However, the types of available responses will vary with consumer types and the availability of the resources. The results characterise the nature, availability and contribution of these flexibility resources including the control regimes necessary to integrate them in the overall

network operation strategy. It will produce a set of template flexibility responses based on different resource types and potential responses.

The interactions between the different stakeholders become more complex in an increasingly flexible power system. Moreover, real-time operation of the system in full view of these interactions is challenging. Therefore it is necessary to understand the impact of control actions across operator boundaries (DSO-DSO, TSO-DSO, TSO-TSO). The establishment of a level of standardisation and commonality in operational procedures of the interaction between system operators and control elements will be researched. These interactions will be in the set power flow exchanges and ancillary services across control boundaries, and will provide for clear responsibility partitioning between stakeholders and control entities. The results include models that characterise these interactions under normal and emergency situations, introducing suitable data rates and models of use by real-time control functions. The results also include these models in a form that is suitable for supporting real-time system control functions as e.g., models to be used by state estimators.

Conflicting control actions can arise between multiple control schemes even though the control actions aim to satisfy a single operating objective. This particularly manifests itself when the schemes operate at different control boundaries. Frequency and voltage control are particularly prone to such conflict and are in evidence across the approaches of individual focussed projects. For instance, demand side measures and primary frequency control acting at the same time to provide a frequency response can result in controller hunting. A similar situation can be observed with voltage controls that are implemented with a mix of conventional (tap changer, exciter controls) and power electronic based voltage control.

In summary, this Electra internal report includes the work of Task T6.1 describing the nature, availability and contribution of these flexibility resources and will identify sources of control conflict and their extent across control boundaries. Furthermore it will establish appropriate control cycles across flexible boundaries of control through which controllers at different system levels should adhere to [2].

1.2 Structure of the report

The document has been divided into four different main chapters that cover the work done in the ELECTRA Task 6.1 and its three different subtasks during the period from May to December 2014.

Chapter 3 provides a summary of the Sub-task 6.1.1 “Characterising flexibility potential and control requirements”. It describes the results of survey carried out among WP6 partners with regard to the characteristics of different flexibility resources including the inherent flexibility of electricity generation, storages, demand response and other type of flexible resources.

Chapter 4 describes the appropriate models that characterize the interactions under normal and emergency situations across control boundaries, introducing suitable data rates and models of use by real-time control functions. The work was conducted in subtask 6.1.2 “Creation of suitable abstractions for modelling interactions across control boundaries”. The fundamental concepts that govern the operation of the present electricity networks are presented. These concepts are applied both to frequency and voltage control of the present electrical network and executed/applied locally or from distance. These operation and control principles through appropriate modifications or adjustments would dominate also the operation of the future electrical networks.

Chapter 5 describes the main outcomes of the work conducted under subtask T6.1.3 “Modelling the conflicts across multiple control schemes”. It includes the definition of controller conflict from a flexible power system perspective, a review of state of the art in power system control conflict and an outline of the methodology for identifying these conflicts during system operation and their impact on system stability.

Chapter 6 provides an overview of experiences from the ELECTRA partners regarding the realization of controllers in demonstration and field test projects. It summarizes best practices and lessons learned which will provide valuable inputs for the implementation of control concepts in WP6 and their testing and validation in WP7.

2 Methodology

The methodology used to collect practical knowledge from the flexibility resources in the grid is based on survey among the WP 6 partners and data collected from literature. The WP 6 partners represent a as from many sides as possible different European electricity market. For the survey a template was prepared and circulated. The questions in the template addressed to different types of flexibility resources, their characteristics and affecting market mechanisms. The flexibility of different resources is able to characterise with parameters which are the amount of power modulation, duration, the rate of change, response time, location, availability, controllability, etc. Important aspect was to receive views how these parameters will develop until 2030 and what are the general trends for development of amount and controllability of this resource types. In all, 12 partners among WP6 answered to this enquiry. The chapter 3 describes the results of this survey. The parameters characterising different flexibility resources provide the technical requirements of these resources for flexible operation of the grid and their suitability for frequency and voltage control in the future.

The work under T6.1.2 was initiated by preparing a template in order to collect material and analysis related to control interactions. This survey was used for the elaboration of the high-level approach which showed the abstractions of interactions between various actors from the point of view of TSOs and DSOs (based on the ENTSO-E [62-63],[65-70] and EDSO SmartGrids reports [61],[64]). The next step was the elaboration of the specific high-level scheme, by means of considering more concrete use cases which make use of flexibility for system operation. The role of the template was to organise the collected information and cover topics such as scope, involved actors, interactions and assets used for scheduling and real-time activation of resources and technical requirements. The focus was in the five main cases, namely; primary, secondary, and tertiary frequency control for TSOs, voltage control and congestion management for DSOs. In order to complement the analysis, two extra cases were studied regarding the use of flexibility under normal operation, such as; regulation and flexibility during fast ramps from Solar/Wind generators.

The work undertaken in T6.1.3 aims to identify the sources of controller conflict and their extent across control boundaries. In order to obtain the comprehensive view of state of the art in this area, a controller conflict example template was prepared, and task participants were requested to provide examples based on literature or their own practical experiences. This forms the basis on which conflicting interactions are identified as well as the development of effective methods of controller conflict resolution. More than 30 unique responses were provided by task participants.

The responses which are most relevant to the proposed definition of controller conflict are presented in section 5.1.2.

Dependencies between all subtasks of T6.1 were used to devise a high level methodology for the identification of controller conflict in light of flexibility resource capabilities and the interactions between these resources or their controllers. Furthermore, dependencies with T3.1 and T4.2.2 were taken into account to ensure that that relevant backdrop of high level grid scenarios and detailed use cases are utilised for identifying controller conflict. This methodology is outlined in section 5.2.

3 Characterizing flexibility potential and control requirements for frequency and voltage control

This chapter provides a summary of the work under subtask 6.1.1. It describes the results of the survey carried out among WP6 partners with regards to the characteristics of different flexibility resources including the inherent flexibility of electricity generation, storage, demand response and other types of flexible resources.

The characteristics and potential capabilities of different types of flexibility resources were collected with the aim of representing as much of the different European electricity markets as possible. In order to collect data related to flexibility resources, a template was prepared and circulated between partners. The research questions addressed different types of flexibility resources, their characteristics, affecting market mechanisms and potential for aggregation. The parameters used to characterise flexibility include the amount of power change, duration, rate of change, response time, location, availability, controllability, etc. It was also expected to receive views on how these parameters will develop until 2030 and what the general trends are for the development and installed capacity and controllability of this resource types. Twelve partners among WP6 replied to this enquiry. The results of this survey are presented in the following subsections of chapter 3. The parameters characterising different flexibility resources provide the technical requirements for applying these resources for the purposes of the flexible operation of the grid and their suitability for frequency and voltage control in the future.

3.1 Electricity generation

The base-load power, peak-load power, reserve power and regulation power described the use of power plants. But after the liberalization of the electric markets the three first terms have lost their official roles. However, the mode of production in power system varies in electricity markets of different countries. For example, the condensing power plant is used often for peak-load power production in Finland whereas for base-load power production in Germany. Base-load power means production capacity which is even and the production amount of electricity is well foreseeable. Base-load capacity is, for example, hydropower, combined heat and power and nuclear power. The annual operating time of peak-load power is normally short and it is used for load levelling for the purpose of reducing peak demand. Peak-load power can be supplied from hydropower plants or generated by gas turbines. The reserve power replaces the base-load power during maintenance or failure of the power plant. The same power plant may be used for both the reserve or peak-load purposes. The regulation power refers to production capacity in electricity markets or other flexible production by which the controllable electricity generation adapts to the variability of renewable electricity generation (wind, solar etc.) and consumption. The regulation capacity is used for hourly, daily or weekly regulation.

The minimum power which can be used to run a power plant, start speed and speed which can be used to carry out power changes affect the regulation properties of the power plants. Gas turbines and motors are the quickest to start. The speed of power change is clearly the highest for motors and their minimum power is low. Also steam and combined heat and power plants can be utilised relatively quickly to increase the electricity production if they are already running and operating under the nominal power production. Slower power changes are possible also with nuclear power but they cannot be carried out continuously.

3.1.1 Hydro power

The regulation characteristics of hydro power are superior in comparison to other electricity generation methods. Hydro power is best suited for regulation purposes, particularly for high-speed regulation. Hydro power is the most profitable alternative in the hour time frame and quicker regulation. Also the main part of the daily power balancing is carried out by hydro power. Exploiting the hydro capacity for high-speed regulation of the power system needs effective short term water regulation and sufficient water stores.

The regulation capability depends on the adequacy of water, season, water system and type of turbine. The regulation causes changes in the water level downstream of the water system. The requirements of the licence also influence on the possibilities of regulation by setting restrictions to the water level changes and water flow rate. River hydro power can be exploited in power system regulation but its regulation characteristics are not as good as the ones of reservoir type hydro power. The regulation characteristics of the river hydro power can be improved by optimizing the utilization of the whole water system. Typical hydropower size and connection to grid are shown in Table 1.

Table 1: Typical hydropower size and connection to grid.

Country	Typical unit size	Connecting grid level	Type of communication channel	Availability of control functions
Finland	In all 250 power plants. In the range P > 100 MW (100-182 MW, 6 plants), 100 MW > P > 10 MW, 54 plants.	P > 10 MW connected to HV and smaller to MV.	Fixed fibre connection for large and medium size plants. Wireless connection for smaller plants.	Frequency and voltage regulation
Italy	In all 2977 power plants. In the range P > 200 MW, 17 plants; 200 MW > P > 10 MW, 293 plants.	P > 10 MW connected to HV 10 MW > P > 100 kW to MV.	Fixed fibre or wired connection for large and medium size plants. Wireless connection for smaller plants.	For P > 10MW, frequency and voltage regulation
Greece	In all 15 (3018MW) large power plants. In the range P > 100 MW (100-437.2 MW), 11 plants), 100 MW > P > 10 MW, 4 plants. Also, 104 (219,84MW) small hydro-electric plants.	P > 10 MW connected to HV 10 MW > P > 100 kW to MV.	Wired and wireless connection.	Frequency and voltage regulation

Latvia	10 units, total: 894 MW, Francis turbines	HV, 330kV	Fixed fibre connection.	Voltage regulation
Poland	There are 73 units in run-of-river power plants, among them : P = 26MW – 6 units, P = 10MW..14MW – 9.	Usually P >10 MW connected to HV and smaller to MV.	Some larger connected by fixed fibre.	Frequency and voltage regulation
Turkey	In the range P > 100 MW 27 plants, P<100 MW 44 plants.	HV	By Turkish Telecom optical fibre utility	Frequency and voltage regulation
Portugal	5239 MW (Total). With 413 MW of Small Hydro power	UHV/HV	Fibre connection	Secondary frequency control and Voltage regulation

Table 1 shows typical size of hydro power plants in some European countries [3...14] and Table 2 shows the control characteristics of hydropower. Largest plants are between 200 MW- 500 MW. Plants P >10 MW are connected to the HV network and smaller capacities are connected to the MV network. In each country there are also many small scale hydropower plants connected to medium or low voltage networks.

Power plants have remote communication and control capability by fibre or wired connection for large and medium size plants and wireless connection for smaller plants. The parameters are possible to change via remote connections by service and mode control, but set points can be changed also locally. Smaller generators have usually fixed control.

Table 2: Some control characteristics of hydropower.

Characteristics	Hydro power	Pumped hydro unit*
Efficiency		
old	87 %	66 %
new	92 %	70 %
Starting times		
cold start-up	n/a	5-10 min
warm start-up	1-2 min	30 s

hot start-up	1-2 s	1-2 s
Minimum power	15-20 %	5-20 %
Speed of power change	high	high

*Pumped hydro unit = one pump turbine; cold start-up = the time from pumping state to electricity generation; warm start-up = from stand idle to electricity generation; hot start-up = turbine is already running.

They have usually continuous availability and simultaneous provisions for both voltage and frequency control. Local voltage and frequency control schemes are normally used. For the synchronous and asynchronous generators the voltage regulation is executed by excitation (Voltage Control and Excitation System), and frequency regulation by rotating speed of turbine (Governor).

The output power controllability for upwards regulation is 20%→100% and for downward regulation 100%→20% of nominal power. The constraints for regulation action are the minimum power of 15-20 %, size of water reservoirs and the regulation time, being in warm start 1-2 min and in hot start 1-2 sec. The duration of control can range from minutes to some hours depending on water reservoirs. Table 3 shows corresponding parameters for power factor controllability of hydro power plants and Table 4 the future trends.

Table 3: Power factor controllability of hydro power plants.

Country	Power factor controllability [cosφ limits]	Constraints of controllability	Duration of control	Response time
Finland	0,7–0,95. (cap/ind)		Mins, hours	Rotating DC exciter machine: 1-2 s, Static exciter: 0,15–0,3 s
Italy	0,7–0,95. (cap/ind)		Mins, hours	Rotating DC exciter machine: 1-2 s, Static exciter: 0,15–0,3 s
Greece	0,7-0,85* (cap./ind.) *0,4 _{ind.} for <35% loading	Voltage, Active power	Continuous	Mins, hours
Latvia	0.85-1 (cap/ind)	-	-	-
Poland	P≥ 10MW typically 0,93cap..0,99cap ÷ 0,83ind..0,88ind, the rest: cosφ ≈1, (cap/ind – in convention of generation)	Generator capability curve	Continuous	Static exciter: less 1 min
Turkey	0,7–0,95. (cap/ind)	-	Mins, hours	Rotating DC exciter machine: 1-2 s, Static exciter: 0,15–0,3 s

Market mechanisms affecting hydro power are the balancing power market for intra-day and hour regulation and bilateral contract for reserves. The big generation units are subject to no production subsidies and small hydroelectric power plants have potential for aggregation. A capital expenditure (CAPEX) for small-scale hydropower can be quite high. Small scale hydropower can be subsidized as for example green certificates in Norway and Sweden.

Table 4: Future trends of hydro power.

Country	How these parameters will develop until 2030? General trends for development of amount and controllability of this resource type?	Additional information:
Finland	Finland has about 2000 MW hydro power capacity for power regulation and it possible to increase 200 MW. By building two reservoirs too, (which are now “frozen” since many years due to the environmental reasons) the regulation capacity is possible to increase for daily regulation by 300-400 MW.	Finland has mainly river hydroelectric power plant with restricted reservoirs. After long regulation, it has to wait until the reservoir of the river has filled.
Italy		Italy has about 22000 MW hydro power capacity for power regulation
Greece	The most important evolution until 2030 is the increase in the number of small hydro-electric power plants as well as the use of more large-scale plants as Pumped-hydro storage systems. Currently, there are two plants with storage capacity 699MW. According to the National Roadmap-2050 report, in order to fulfil the RES development targets, about 1 GW of PHES capacity is required by 2020 and 2 to 5 GW up to 2050, depending on the scenario.	
Latvia		Daugava HPPs Plavinas+Rigas+Kegums) in total generated 2852 GWh of electricity, which constitutes 59% of the total electricity output. This approximately corresponds to the long-term average electricity output. Although the capacity of the hydropower plants is great, their

		ability to generate electricity depends on the water inflow in the Daugava river. The capacity of the hydropower plants usually can only be fully utilised during the spring high water period, which lasts approximately two months. The greatest volume of electricity generation usually occurs in April.
Poland	A significant number of new installations of run-of-river power plants of power $P \geq 2\text{MW}$ shouldn't be expected till 2030. Building the second stage of fall on Wisła near Włocławek with a new 100MW run-of-river power plant has been considering for long time, but still the final decision hasn't been made up.	The share of run-of-river power plants of total installed capacity amounts to 2%.
Turkey	EÜAŞ has more than 12.000 MW hydro power capacity and this correspond to nearly 20 % of Turkish installed capacity. According to recent searches Turkish energy demands will duplicate in 10 years. Due to this prediction EÜAŞ's mission is supply this demands by using hydrolic power capacity.	
Portugal	For 2030 is expected an increase of the total hydro power capacity for 9650 MW.	

Concerning the future trends Turkey is the only country that has possibilities to increase hydro power capacity significantly. The hydro power is based on river power plants in many countries and the available capacity is already built in spite of the small hydro power plants which are still possible to increase a minor amount.

3.1.2 Thermal power

Typical thermal power plants are condensing, combined heat and power (CHP), gas turbine, motor and nuclear power plants. The nuclear power plants are discussed in the next paragraph 3.1.3. The starting time of condensing power plant depends on the time when the plant was last time in operation (cold start or warm start). The start-up of warm plant takes about two hours but the start-up of the cold plant takes more than 10 hours. If the maintenance of the start readiness of the power plant is neglected, the return to production may take months.

The control characteristics of new coal fired plants are in the development phase with regards to the minimum power. The objective is the running with 20 % part-load due to the development of feeding of the fuel. New technical solutions are also in the development phase allowing higher speed of the temperature rise for the main components and solutions maintaining the temperature of components during shutdown. Frequency and voltage control can be provided at the same time, given that the working point of the synchronous machine and of the prime mover are within the capability limits.

The technical control characteristics of the motor power plants are insurmountable in comparison to the other thermal power plants. The high maintenance charges of the motor power plants remain reasonable in the regulation power projects in the case the operation time is below 50 000 hours during the lifetime of the application. Motor power plants and gas turbines are normally used as system reserves.

The exact values for the speed of power change are difficult to give for the combined heat and power plants (CHP) intended for cogeneration of district heating or cogeneration of industry. The increase of the electricity power decreases the heat power or vice versa, in the case, the fuel efficiency remains constant. An advantage of using the cogeneration in the power system control is the long and continuous power regulation possibility, because the CHP plants are in operation due to the heat production. On the other hand, the control possibilities of the CHP plants for district heating vary according to the season and temperature. The minimum power characteristics of the cogeneration based on the fluidized-bed boiler are quite good because the combustion process is stable. The fluidised bed is a large heat storage allowing the maintenance of the high temperature of the power plant for long time during the shutdown. The cogeneration power plant for district heating is normally run according to the heat demand. Therefore the possibilities to participate for generation of regulation power are low during the peak demand of heat power. Also during the summer time the cogeneration may be too expensive due to the low heat demand. It is possible to increase the flexibility of the cogeneration by heat storages, and in this way to decrease the dependence between electricity and heat production. For example, in Finland there are many heat storages in use in the capacity range of 10 MWh to 10000 MWh and in the maximum power range of 1 MW to 130 MW. The energy efficiency of the heat storages is over 90 % in short term usage.

The main driver of the cogeneration in industry is the heat production whereas the electricity is only the secondary product. However, it is possible to increase the flexibility and electricity generation of the industry and its value on the electricity market. Depending on the profitability of the industrial production, flexibility can be achieved by increasing the electricity generation at peak demand, when the price of electricity is high, at the expense of heat production to industrial processes. Control characteristic of the thermal power plants are shown in Table 5. Table 6 shows typical gas power plants and their connections to grid and control.

Table 5: Control characteristics of the thermal power plants.

Characteristics	Condensing power plant	Combined power plant (CHP)	Gas turbine	Motor	Nuclear
Typical unit size					
MWe	600-900	60-400	10-300	1-20	1000-1600

Efficiency					
old	40%	50%	32%	45%	33%
new (max)	47%	61%	38%	48%	37%
Starting time					
cold start-up	5-10 h	2-3 h	10 min	15 min	2 days
warm start-up	3-5 h	1-1,5 h	10 min	15 min	1 day*
					8-16 h,
					60-100%
hot start-up	1,3-2,5 h	0,5-1 h	10 min	5 min	2-4 h
Minimum power	40%	40-50%	50%**	30%**	(15-)30%
Speed of power change	3-6 %/min	4-6 %/min	5-10 %/min	25%/min	

*after shutdown of many hours

** the emission threshold of nitrogen dioxide exceeds by running lower power. The technical minimum power 10 %.

Table 6: Typical gas power plants and connections to grid and control.

Country	Typical unit size	Connecting grid level	Type of communication channel	Availability of control functions
Belgium	100kW – 400MW	LV/MV/HV	Depends on the size of the unit, fibre connection	Frequency, voltage control, power balancing
Denmark	In the range of 100 - 600 MW	HV		Voltage and frequency
Latvia	2 gas turbines and 1 steam turbine, 2x48MW and 1x48MW total: 144MW, 1x1 CCGT-2/1 (2008) 413MW (steam turbine 122(150)MW, gas turbine 291MW) and 1x1 CCGT-2/2 (2013) 419MW (steam turbine 125(145)MW, gas turbine 294MW), total: Cogeneration 832 MW, Condensation 881 MW	Gas turbines 110 kV and 330kV, steam turbines 110kV	Fixed fibre connection.	Voltage regulation
Poland	There are 5 turbine sets of power P > 50MW: In the range P = 198MW..235MW	One gas-steam power plant (198MW) is	Fixed fibre connection for large and	Voltage and frequency regulation

	– 2 turbine sets, P = 101MW..116MW – 2 turbine sets.	connected to EHV, the rest usually to HV, smaller to MV.	medium size plants.	
Turkey	In the range P > 100 MW 18 plants, P<100 MW 4 plants.	HV	By Turkish Telecom optical fibre utility	Voltage and frequency control
Portugal	3829 MW (Total, include non-renewable cogeneration	HV	Fibre Connection	Frequency and Voltage regulation

Gas fired power plants are available for control continuously. Frequency and voltage control can be provided at the same time, given that the working points of the synchronous machine and of the prime mover are within the capability limits. Concerning the output power controllability gas fired power plants are able for upwards regulation: 40% ->100% of nominal power, and for downwards regulation: 100% -> 40% of nominal power. The technical minimum is 20-50 % of nominal power and the starting phase takes (typical) 2-15 minutes. For the power factor controllability, the $\cos\varphi$ limits are 0,7-0,95 ind/cap. The other constraints are:

- excitation limits: field heating limit (max provision of reactive inductive power);
- under excitation limit (max consumption of reactive inductive power);
- armature heating limit (constraints with max active power output).

The duration of control may be from min to hours. Response time of control is 1-2 sec, using rotating DC exciter machine, and 0,15 - 0,3 s for static exciter.

With regard to the general development trends for the amount and controllability of this resource type, the Polish Power System has 917 GW of power capacity of gas and gas-steam power plants. Realisation of investments planned to year 2030 can increase the amount to more than 6500 MW [11]. The share of gas and gas-steam power plants of total installed capacity amounts to 2,4%. Turkey has more than 13.000 MW of thermal power capacity and this correspond to nearly 20% of Turkish installed capacity. According to recent searches Turkish energy demands will duplicate in 10 years [13]. For 2030, Portugal is expecting a decrease of the total natural gas capacity for 1766 MW. For 2030 is expected a gradual disqualification of all thermoelectric power station until 2030 and the licensing of four CCGT groups (2017) [22].

3.1.3 Nuclear power

Nuclear power plants are normally run in full power because the capital costs are high but the operating costs are low due to the low fuel cost. The reduction of the operating hours of plant decreases the profitability of investments. The downward control is the primary because nuclear power plants are run normally in full power. The need for downward regulation is most plausible during low demand. The regulation of the nuclear power plant succeeds best when the time and reduction of demand are foreseeable. Multiple changes of power production lead to no-optimal use of fuel. Any change of the operation state increases the risk of the failure occurrence and may lead to an unwanted shutdown. For example, due to these reasons, the Finnish nuclear authority (STUK- Radiation and Nuclear Safety Authority) has restricted the speed of power change, its magnitude and frequency by specifications.

The generated power can be controlled by affecting to the nuclear reactivity, also known as to the number of nuclear fissions. The reactivity of the pressurised water reactor (PWR) is regulated by control rods and by the boron concentration of the reactor water. The reactivity of the cooling water reactor (CWR) is regulated by control rods and by the pumps recycling the reactor water. The technical characteristics of the fission reactors restrict the ability to regulate the nuclear power plant. The restricting factor for the speed of changes so called “xenon poisoning” affects to the stability of the power distribution in the nuclear core. The xenon stability after the power change is possible to achieve in about 40 hours. This restricts the possibilities for the power changes especially in the end of refuelling interval.

The new nuclear power plants are designed more suitable for control purposes. According to the clarifications done by Elforsk in Sweden for the Areva European Pressurised Water Reactor (EPR), the regulation characteristics for power changes are the following:

- Down regulation (power drop) 5%/min in the power range 100% -> 60% and back in the daily operation.
- Down regulation 5%/min in the power range 100% -> 25% and after that the up-regulation 2,5%/min in the power range 25% -> 60% . Main priority is down regulation.

The constructions of the Mitsubishi, Toshiba and General Electric-Hitachi have the same control characteristics. France generates relatively the highest part of electricity by nuclear power in the world. The power plants are controlled according to the variation of the demand. Nuclear power is also used for frequency control. The controllability of the nuclear power plants is also taken in the account in the development of new reactors, and also the international nuclear association have given new recommendation for controllability of new power plants [14].

Typical unit sizes of Finnish nuclear power plants are 2x500 MW and 2x880 MW and one 1600 MW unit is under construction. They fit to voltage and frequency control, and they are continuously available for control but control is rarely applied. For the output power controllability [MW or % of nominal] the minimum power is 30 % of nominal power in continuous operation. The cold start takes 2 days and warm start 1 day (8-16 h; 60% ->100 %) and hot start 2-4 h. The nuclear power plants are intended for base load operation, and the power regulation means that the nuclear fuel is not used optimally. Duration of control may be from minutes to hours and the rate of change [MW/s] is 2,5-5 %/min of the nominal power. Response time is seconds.

For the power factor controllability, the cos ϕ limits are 0,7–0,95 (cap/ind). Constraint of controllability is that generator must be able to produce the same amount of reactive power as the nominal active power for 10 s and minimum voltage is 70% of nominal voltage. Duration of control is in min and the response time for a rotating DC exciter machine is 0,2-0,5 s: 0 ->90% voltage in up-regulation, and 0,2-0,8 s in down-regulation.

Concerning the future trends the nuclear capacity in base load operation will be about 4000-6000 MW in Finland and from the control point of view the main priority is the down regulation [3]. The first nuclear power plant in Poland will start operation in year 2024 with generating capacity of 1000 MW, which is going to reach 3000 MW in 2030. Total capacity of nuclear power plants will reach 6000 MW in 2035, [15].

3.1.4 Wind power

Wind power, besides the sun power, is increasing most quickly in the world in the coming years. The modern wind power plants are able to active and reactive power control. The power of wind turbine is possible to control in three different way; Pitch Controlled Wind Turbines, Stall Controlled Wind Turbines and Active Stall Controlled Wind Turbines.

- On a pitch controlled wind turbine the turbine's electronic controller checks the power output of the turbine several times per second. When the power output becomes too high, it sends an order to the blade pitch mechanism which immediately pitches (turns) the rotor blades slightly out of the wind. Conversely, the blades are turned back into the wind whenever the wind drops again. During normal operation the blades will pitch a fraction of a degree at a time - and the rotor will be turning at the same time.
- (Passive) stall controlled wind turbines have the rotor blades bolted onto the hub at a fixed angle. The geometry of the rotor blade profile, however has been aerodynamically designed to ensure that the moment the wind speed becomes too high, it creates turbulence on the side of the rotor blade which is not facing the wind. This stall prevents the lifting force of the rotor blade from acting on the rotor. Around two thirds of the wind turbines currently being installed in the world are stall controlled machines.
- Technically the active stall machines resemble pitch controlled machines, since they have pitchable blades. In order to get a reasonably large torque (turning force) at low wind speeds, the machines will usually be programmed to pitch their blades much like a pitch controlled machine at low wind speeds. When the machine reaches its rated power, however, you will notice an important difference from the pitch controlled machines: if the generator is about to be overloaded, the machine will pitch its blades in the opposite direction from what a pitch controlled machine does. In other words, it will increase the angle of attack of the rotor blades in order to make the blades go into a deeper stall, thus wasting the excess energy in the wind, [15].

In addition of downward control also the upward control is possible to a certain extent, if the wind generation is first curtailed. Upward regulation requires stable wind conditions. The second option for upward regulation is to exploit momentarily the kinetic energy stored in the inertia of the rotor. By this way the wind power plants can momentarily support the system frequency. The grid operators have given some requirements to wind turbines:

- The wind turbine has to be able to control the upper limit of its active power generation. By the controllable upper limit it is possible to ensure if needed that the active power production will not exceed the predefined level.
- The rising speed of the active power production has to be able to restrict so that the speed of power change is possible to the speed of 10 %/min of the nominal power.
- The active power generation downward has to be able from 100% -> 20 % from nominal power in 5 s.

Based on the survey among Electra WP6 partners the following tablets Tables 3-9 show some characteristics concerning grid connections, frequency and voltage control of wind power.

Table 7: Typical wind power size and connections to grid.

Country	Typical unit size	Connecting grid level	Type of communication channel	Availability of control functions
Denmark	From 1 MW to 200 MW	MV/HV		Voltage and frequency
Finland	1 MW, 3 MW and 5 MW units and wind parks in scale of 100 MW. The whole capacity 500 MW	HV	Fixed fibre connection	Active power control, reactive power control
Greece	In all 106 wind farms (1520,02MW). 69 of them (1358,32MW) are >10MW and they have the obligation of regulated output.	32 (462,47MW) connected to MV while 37 (895,85MW) to HV.	Fiber-optic communication.	Voltage and frequency
Poland	Total of 873 wind power plants. In the range $P \geq 100$ MW (100-177.5 MW) - 3 plants, $100 \text{ MW} > P \geq 40$ MW - 28 plants, $P \leq 40$ MW – 842 plants.	$P > 10$ MW connected to HV and smaller to MV. 3 plants connected to EHV (177.5 MW, 135 MW and 100 MW).	Fixed fibre connection for large and medium size plants. Wireless connection for smaller plants.	Voltage regulation, frequency control (for wind farms with $P > 50$ MW).
Portugal	4448 MW	UHV/HV	Fibre Connection	Frequency and Voltage control
Turkey	In the range $P > 100$ MW 6 plants, $P < 100$ MW 70 plants.	HV, MV	By Turkish Telecom optical fibre utility	Voltage and frequency control

Table 8: Output power controllability for wind power

Country	Output power controllability [MW or	Constraints of controllabili	Duration of control	Rate of change	Response time [s or
---------	-------------------------------------	------------------------------	---------------------	----------------	---------------------

	% of nominal	ty	[min]:	[MW/s]:	min]:
Denmark	For upwards regulation: possible only if the farm is operating below the available power output. For downwards regulation: possible (over-frequency regulation). Can be realized both at wind turbine and farm level (i.e. reducing the output of the wind turbine or shutting down one or more wind turbines in order to reduce the overall farm output)	Wind availability (for upward)	Continuous	Any for downward; limited to the wind available for upward	seconds
Finland	For upwards regulation: not applied	Natural restrictions relating to wind availability.	Seconds to hours	12%/sec	5 seconds for completed downregulation
Greece	For upwards regulation: Defined by system operator; For downwards regulation: Defined by system operator	Voltage, Power Factor	Continuous	Defined by system operator	1 min
Poland	For upwards regulation: 0%→100% of nominal power; For downwards regulation: 100%→0% of nominal power	Possible for wind speed higher than turbine cut-in speed.	Unlimited.	maximum 25%/s for both directions	seconds
Portugal	For upwards regulation: N.A; For downwards regulation: Although not included in the grid-code, around 1.4 GW of wind power capacity offered, in a public tender, the ability to be curtailed (reduce active power) in an annual		min		

	amount of energy corresponding to 50 hours at rated power and also the ability to support primary frequency control within a de-load power curve of $\pm 5\%$.				
--	---	--	--	--	--

Table 9: Power factor controllability for wind power.

Country	Power factor controllability [cos ϕ limits]	Constraints of controllability	Duration of control	Response time
Denmark	Capability limits of PWM converters (roughly 0.8 power factor)	Capability limits of PWM converters or capacitors	Continuous	Seconds
Finland	0,95 cap – 0,95 ind.	In normal operation remains in power factor 1.	Minutes to continuous operation	Seconds
Greece	0,835-0,835 (cap./ind.)	Voltage, Maximum power	Continuous	Seconds
Poland	0,975–0,975. (cap/ind)		unlimited	for asynchronous machine: 1 ÷ 2 s, for full converter: 0,2 ÷ 0,3 s
Portugal			Minutes	Seconds

General trends for development of the amount and controllability of wind power in Denmark shows that the degree of controllability of active power will improve in the moment that more newly installed wind turbines (and wind plants) will possess these characteristics [21]. Naturally it depends also on the willingness to operate the wind farm at reduced output. In Finland, the amount of wind power is expected to increase. Wind power plants are requested to participate more actively in network control [16]. In Greece, the national roadmap for the development of RES in Greece predicts an increase in the wind farms which are expected to reach 7500 MW by 2020 [18-20]. Installed capacity of wind generation in Poland reached over 3676 MW. Total power of wind farms with signed connection conditions equals 13 300 MW (5700 MW to EHV, 5270 MW to HV

and 2430 to MV), total power of wind farms with issued connection conditions exceeds 6200 MW (2440 MW to EHV, 3600 to HV and 160 MW to MV). Therefore, the installed capacity of wind generation is expected to be gradually rising over the following years [17]. In Portugal, for 2030 is expected an increase of the total wind capacity for 6400 MW [22]. In Turkey, the private companies have more than 4.000 MW wind power capacity and this correspond to nearly 6 % of Turkish installed capacity. It will be 25 GW and incentives will be finished at 2030. Intraday market will be applied at 2016. RITM will be used for all wind plants for monitoring and controlling [13]

3.1.5 Photovoltaic

Solar-sourced electricity can be generated either directly using photovoltaic (PV) cells or indirectly by collecting and concentrating the solar power to produce steam, which is then used to drive a turbine to provide the electric power (CSP). The main control problems with solar plants are related to sun tracking and control of the thermal variables. Although control of the sun-tracking mechanisms is typically done in an open-loop mode, control of the thermal variables is mainly done in closed loop. Solar plants exhibit changing dynamics, nonlinearities, and uncertainties, characteristics that result in detuned performance with classical PID control. Advanced control strategies that can cope with these issues are needed for better performance and for decreasing the cost per kilowatt-hour generated [23].

The following analysis covers mainly the results of survey received from Austria and Poland. Typical unit sizes of PV power plants in Austria are:

- 0-5 kW more than 143 MW
- 5-20 kW nearly 15000 PV plants with more than 150 MW
- 21-50 kW more than 1000 plants with more than 35 MW
- 50-100 kW more than 250 with more than 18 MW
- >100 kW more than 360 PV plants with more than 115 MW

In total nearly 40000 plants with total rated power of more than 450 MW; Installation peaks at 4-6 kW and 19-20 kW.

Poland has total of 39 plants in the range of $P < 0.1$ MW 31 plants and $0.1 \text{ MW} < P < 1$ MW 8 plants.

Power plants are connected to the low voltage network in the range of 20 – 50 kW and large plants to medium voltage network. The small-scale PVs are most growing e.g. in Denmark installed at households and office buildings and feeding directly into the distribution network.

Type of communication channel is fixed fibre connection for large and medium size plants and wireless connection for smaller plants.

- Monitoring
 - Currently: Mainly proprietary vendor-specific protocols are being used. The PV-inverter systems also provide web-based interfaces to configure the system and to show the production profiles.
 - In Future: IEC 61850 and SunSpec (based on Modbus) should be used to have a standardized interface to the PV-inverter functions and to monitor the PV plants. Especially, IEC 61850-7-420 - Communications systems for Distributed Energy Resources (DER) - Logical nodes IEC 61850-90-7 - Object Models for Photovoltaic, Storage and other DER inverters should be applied in future installations.
- Control

- o Currently: Vendor specific solutions are being used today for controlling PV systems (mainly bigger PV plants). The Modbus approach (serial communication) is commonly used today but Modbus/TCP (Ethernet-based mapping of the serial communication) is already being provided by some PV-inverter vendors.
- o In Future: IEC 61850 and SunSpec (based on Modbus) should be used to have a standardized interface to the PV-inverter functions and to monitor the PV plants. Especially, IEC 61850-7-420 - Communications systems for Distributed Energy Resources (DER) - Logical nodes IEC 61850-90-7 - Object Models for Photovoltaic, Storage and other DER inverters should be applied in future installations.
- Balancing market:
 - o Currently: Only protocol IEC 60870-5-101 is allowed (all balancing markets FCR, mFRR, aFRR). Only point-to-point connection, no Ethernet.

PVs are heavily subsidized today and thus cannot be used for balancing purposes. At least until the present supporting schemes will be changed. PV plants are available for voltage control so far but also frequency control is possible in the future. Voltage control is normally implemented locally by reactive/active power droop control, $Q(U)$, $P(U)$, $\cos\phi(P)$, constant $\cos\phi$. No fixed, local or centralized frequency control schemes are applied for the time being but 50.2 Hz control and islanding detection are implemented. Flexibility for control scheme and parameter changes is locally possible and also the possibility of simultaneous provision of these functions. Availability for output power and power factor control is continuous, but depends on solar radiation.

Output power controllability:

- For upwards regulation: in case of upfront curtailment 0-100% possible
- For downwards regulation: 100-0%
- Duration of control [min]: continuous, depending on solar radiation
- Rate of change [MW/s]: $\sim 10\%/s$
- Response time [s or min]: s

Power factor controllability [$\cos\phi$ limits]: 0,9–0,9. (cap/ind)

- Constraints of controllability: 0.9 for plants < 13.8 kVA and 0.95 for smaller plants
- Duration of control [min]: continuous, depending on solar radiation
- Response time [s or min]: s

PVs are subject to high changes depending on sun conditions. Therefore, it requires balancing power what affects balancing power market and to some extent electricity markets. PV plants have potential for aggregation to virtual power plant and participation in markets as for example balancing markets. Concerning the future trends, PV capacity will increase significantly and it enables the participation in the frequency and voltage regulation especially for plants connected to medium voltage level [16, 21].

3.2 Demand response

3.2.1 Industrial loads

Processes where the electricity consumption can be modulated are suitable for demand response in industry. Typically modulation is subject to constraints as buffer management, throughput, production numbers. This type of flexibility is suitable for continuous operation. Examples of

processes are many industrial installations e.g. electrolysis, reduce speed of a rolling mill installation, pulp and paper processes, extruder operation, etc. The typical unit size offered to markets varies from 100 kW to several mega Watts. The minimum size for participation in reserves varies from 1 MW to 10 MW and for real time disconnection 20 MW in some countries. As an example, the potential is about 1200 MW in Finland and about 4000 MW in Turkey. Industrial loads are normally connected to MV, HV or EHV network and the communication channel used is phone call, relay-connected, automated or manual dis-connectable loads. They are available for balancing, voltage control at feeder level and frequency support functions. Frequency control scheme can be local and also centralized by phone call of TSO for real time disconnection. Power controllability for upwards regulation depends strongly on the conditions, but typically limited. Downwards regulation is more suitable for fixed power agreed. The control is subject to constraints. Typically modulation is subject to constraints as buffer management, throughput, production numbers etc. Duration of power control may be from minutes to hours and response time can be from milliseconds to minutes. In the power factor controllability the $\cos\phi$ limits varies typically 0,7–0,95 (cap/ind) and the duration of control may be from minutes to hours and response time is in the range of seconds. Affecting market mechanisms are reserve markets including frequency containment reserves, balancing, day ahead market, BRP portfolio management and they have potential for aggregation. Industrial loads are continuously available for control in so far as the industrial process is running. An activation may result in an opposite reaction of the unit for some time but it depends on the industrial process. Frequency Containment Reserve for Disturbances (FCR-D) is activated immediately with frequency $30 \text{ s} \leq 49,70 \text{ Hz}$ or $5 \text{ s} \leq 49,50 \text{ Hz}$ and load can be reconnected to grid, when frequency is at least 49.90 Hz for five mins in Finland. The activation is Immediate with frequency $\leq 49,1 \text{ Hz}$ and load can be reconnected to grid, when frequency is at least 49.90 Hz for five mins in Italy. Concerning the future trends the potential in Italy is max 4318 MW (4297 within 0.2 sand 21 within 5 sec) activated automatically, [24]. Heating ventilation and air conditioning applications in public and office buildings will be a very relevant part of demand response, which has been growing due to implementation of Building Automation Systems (BAS).

3.2.2 Electric vehicles (EV)

Electric vehicles (EVs) are commonly recognized as smart grid assets in addition to their environmental benefits due to their flexible charging time.

They can be utilized to balance power fluctuations caused by the high penetration of intermittent renewable energy sources in the transmission system level. The studies performed in US, UK and Denmark are summarized in the following three paragraphs, [25].

Kempton et al. [26] [27] analyzed the potential profits of vehicle to grid (V2G) support by comparing it to existing ancillary services and found that participating regulation power market appears to be most promising and offers a substantial earning potential to EV owners. This is because: (a) it has the highest market value for V2G among the different forms of electric power (much higher than peak power, for example), (b) it minimally stresses the vehicle power storage system, and (c) battery-electric vehicles are especially well suited to provide regulation services. The electric vehicles can participate in the regulation services individually or by joining a fleet, the communication can be facilitated by power line and wireless control connections. It is advocated that fleets are more easily accommodated within existing electric market rules, which typically require power blocks of 1 MW. To fulfil the concept of V2G, each vehicle must have three required elements: (a) a connection to the grid for electrical energy flow, (b) control or logical connection

necessary for communication with the grid operator, and (c) controls and metering on-board the vehicle. By predefining the wanted driving distance and the comfortable buffer, the electric vehicles can be connected to the grid and then participate the regulation service market. It is also learned from the studies [26] [27] that important variables for the V2G market are: (a) the value of ancillary services in the area, (b) the power capacity of the electrical connections and wiring, and (c) the kWh capacity of the vehicle battery. The amount of time the vehicles were on the road or discharged did not turn out to be a major variable. The results showed that battery electric vehicles fleets have significant potential revenue streams from vehicle to grid.

Based on the survey in UK [27], [28] the typical size of electric vehicle for demand purpose is about 2kW for vehicle-to-grid (v2g) and the total available capacity depends on the number of EVs in the area. EVs are connected to low voltage network and they are available for primary frequency control. The frequency control scheme used is local EV battery discharge or disconnection of EV during low system frequency events. Concerning power controllability the upwards regulation is possible up to 100% of stored energy. The constraints of controllability depend on the state of charge (SOC), it is assumed that EV only contributes to primary frequency control when SOC is above a predetermined level. Also different EV types and usage result in a temporal distribution of EV available for response which requires scheduling. Duration of control takes seconds and the response time is seconds with up to 100ms charger time delay. Affecting market mechanism is bilateral contracts with aggregator within TSO's balancing mechanisms framework. Charging of the EVs (as energy storage) utilizes a dual tariff that is cheaper during off-peak hours. Aggregation is necessary for the control to be effective. Studies show that EVs can play an effective role in contributing to primary frequency control, thus potentially meeting a larger proportion of the secured sudden generation loss of 1800 MW in the UK. It is also projected that 5-36 million EV charging controllers will be deployed by 2050. The projections are based on different scenarios (e.g. high electrification, low electrification).

In term of the Danish Power system, Divya et al. [30] carried out a study investigating the feasibility of integrating electric vehicles in the Danish electricity network which is characterized by high wind power penetration. They found that electric vehicles have the potential to assist in integrating more wind power in 2025 when the electric vehicle penetration levels would be significant enough to have an impact on the power systems. Østergaard et al [31], [32] shows that intelligent integration of electric vehicles in the Danish power system with high wind power penetration has substantial socio-economic benefits due to its balancing capability. Pillai and Jensen [33] investigated the V2G regulation capabilities in the West Denmark power system by using a simplified load frequency control model, in the study, they used an aggregated battery storage model and generators model. The results indicated the regulation needs from conventional generators are significantly minimized by the faster up and down regulation characteristics of the EV battery storage.

All these results indicate that it is feasible to participate in the electricity market and provide ancillary service to the grid. It is summarized and concluded from the literature that a new business entity, namely the EV fleet operator (FO) has been widely proposed capturing the new business opportunities by providing the multiple services of EVs and then by this contributing to the challenges solving of power system operator. Alternatively names for an EV FO are used such as EV virtual power plant, EV aggregator, EV charging service provider or EV service provider (EVSP). The new entities [34], [35] could be independent or integrated in an existing business function of the energy supplier or distribution system operator.

However, a large scale application of EVs also mean new loads to electric utilities, and undesirable peaks may exist in the distribution network when recharging the battery [36]. Research has

indicated that uncoordinated charging [37] or price responsive charging [38], [39] bring congestion and voltage violation problems to the distribution system operators. The price responsive charging means the EVs may react to the wholesale/regulating power market prices in a correlated way since they react to the same electricity price. For example, when EVs postpone charging until the electricity price is at lowest, they will create a peak demand at that moment. To address the congestion problems introduced by the uncoordinated charging or price responsive charging, much research has been done to coordinate the interests of different actors such as optimize the charging cost of electric vehicles as well as respecting the hard constraints imposed by the distribution system operator. The proposed solutions include centralized control strategies [38],[40] dynamic tariff based approach [41] and market based control or transactive energy approach [39], [42], [43]. All the proposals use the charging flexibility of electric vehicles.

For more information, the reader is referred to [44] where the authors presents a review regarding the using of electric vehicle fleet as a kind of demand response resources. More specifically, the EVs aggregation objectives, the control strategies used by the aggregator, the battery modelling technology and driving pattern of EVs, and the control algorithms are reviewed.

PHEV is now also able to supply electrical power to home using a V2H system in addition to be able to be charged from a domestic outlet. To date, the use of a V2H system had only been approved for all-electric vehicles such as the Mitsubishi i-MiEV series. The V2H system makes it possible to use the PHEV as an emergency power source, supplying electricity stored in the vehicle's drive battery to run domestic appliances in a power outage or a natural disaster. This is a world-first for a plug-in hybrid electric vehicle [113].

In summary, it is safe to conclude that EVs can be used to provide services to various actors in a smart grid environment. However, it will mostly bring localized distribution problems. Therefore, knowing where those loads will occur, having the data and tools to analyse their impacts, and providing incentives for network-friendly charging patterns will be the key to both consumers and utilities realizing the potential of electric vehicles. Furthermore, how to handle the 'controller conflict' is also an important issue such as the activation requested from the TSO might introduce the congestion problem to the DSO level.

3.2.3 Household appliances

Various household appliances can participates in demand response if the device is scheduled for operation with a due time and for example, the device has a fixed load profile like dishwashers, washing machines, tumble dryers, fridges, water heaters, space heating etc. It is expected a growing share of heat pumps applied for space heating and cooling. Several countries will prohibit use of heavy fuel-based heating at households from 2017 (Norway, Denmark +) and support installation of heat pumps for space heating purposes. Heat pumps represent a great resource for DR schemes.

Their typical sizes of household appliances are from 100 W to 5 kW and they are connected to low voltage network. Communication channel may be, for example, via smart meters using automated direct control of on/off switching or indirect with price signal (market based control) or manual (dis)connection. Household devices can be aggregated for voltage control at feeder level and also for frequency support. Frequency control scheme may be fixed or centralized control through directly sending external control signals to frequency-responsive household appliances. Fixed control means automated on/off switching of the device based on predetermined threshold frequency. The control scheme can be switched to consumer-based scheme that involves active

participation from the demand side and consumers managing their household appliances on the basis of their own preferences. Or number of fridges participating to the control may change according to the constraints of users. Direct load control and consumer-based scheme have a high possibility to be issued to consumers at the same time. Household appliances can be applied for power control of downwards regulation 100% of nominal (switch off). In the case of fridges, the temperature of the fridge room may cause constraints of controllability. The load profile and the “due time” are predefined. The starting time of the load can be chosen freely, but in some cases started load can be interrupted and in some cases this is not possible. Duration of the control may be from minutes to hours, but for fridges it depends on the thermal constant of the fridge and also on the amount of food located inside. Rate of power change is high (100 % power on/off) and the response time is in seconds including delays which may be determined by communication latencies. With regard to market mechanisms there are no business cases without aggregation and they depend strongly on business model. Participation is possible in the reserve, balancing and day ahead markets.

Control of household equipment may be available at discrete times, depending on the customers scheduling. An activation of control may result in an unwanted reaction of the unit for some time which is so called rebound effect. For example uncoordinated control may lead to synchronization of the fridges dynamics determining a correlated on/off cycles. Also load will be delayed, no extra consumption on an individual basis. On an aggregated level, however, a major activation/delay may result in a concentrated activity of the loads afterwards. Will demand response activations may influence the overall annual energy consumption of the unit depending on consumers’ energy consumption patterns and preferences.

With regard to the general trends until 2030, scheduled load is not used in any commercial demand response program yet. Now, direct load control and price-incentive scheme could achieve an average 8%-15% demand reduction during peak time durations for residential loads. With the active participation from the demand side, (or combined with direct load control/price-incentive scheme), the potential demand reduction would be hard to estimate, [45...48].

3.3 Energy Storage

Storage systems can contribute to the frequency and voltage control mechanisms. The frequency of the grid may be altered by short-term, random fluctuations in demand or power provision which requires either power or loads adjustment for recovering the load-generation balancing; therefore this service is also known as continuous control or load following. This is a short-term service, primary frequency control acting within seconds and with a minimum duration of 15 minutes. Charging and discharging of the storage system at the right moments (response within milliseconds to seconds) can help to preserve the balance between consumption and generation [49]. Storages can also provide secondary and tertiary frequency control. Basically the same control algorithm as for secondary control applies but tertiary control is often requested manually by the system operator [50].

Reactive power compensation is needed when big voltage variations occur in the grid (e.g. voltage sags and swells). A voltage sag is defined as a temporary voltage drop and voltage swell is defined as temporary voltage rise which pose serious instantaneous problems in the grid. Voltage variations can cause production interruptions and damage to machines. In order to avoid bigvoltage variations, an energy storage system can be installed to smooth the power fluctuation and control the flow of reactive power in the grid. Voltage support may also be operated at a very short timescale of 2-5 seconds. This specific task performed by the storage unit depends on its operation mode. The storage system compensates for the reactive power and load unbalance [51]. A flywheel energy storage has a fast charge and discharge speed and therefore it is capable of

supplying the necessary active and reactive power demanded by the load in a very short time. With that, flywheels could be a good way to solve voltage variation problems. [52] By controlling the reactive power the voltage level of the network can be regulated. By providing reactive power locally the grid can be used more efficiently and therefore the losses and voltage variations in the network can be reduced. Under a big voltage variation (sag or swell) condition, the speed of the flywheel varies in order to supply or absorb the required power. Reactive power compensation can be controlled either directly from the load or from the grid voltage.

The grid applications for storage technologies can be loosely divided into power applications and energy management applications, which are differentiated based on storage discharge duration. Figure 1 shown below, presents power ratings and discharge times required for different types of network services [53].

Power rating

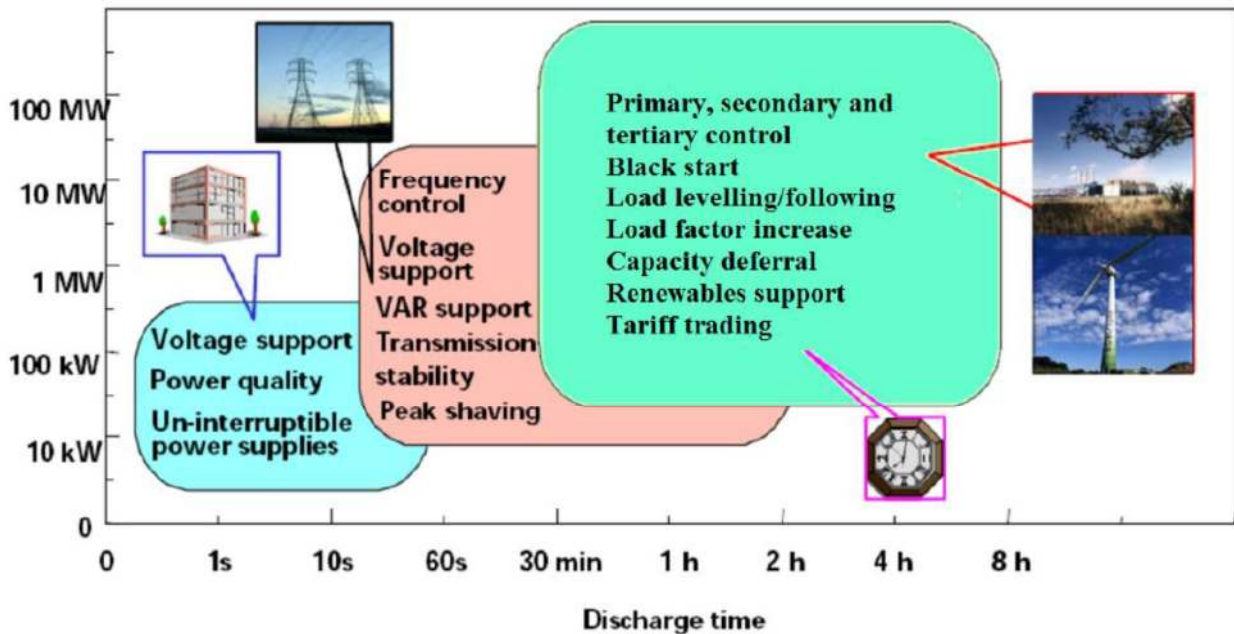

Figure 1: Power ratings and discharge times required for different types of network services.

3.3.1 Electricity storage

Conventional battery categories today include the most technologically and commercially mature technologies, i.e. Lead Acid batteries (PbA) and nickel based batteries, including Nickel Cadmium (NiCd) and Nickel Metal Hydride (NiMH) batteries. All conventional batteries are commercially available on the market. High recyclability improves usability. Rechargeable type conventional batteries, which could be used in smart grids, are PbA, NiMH and NiCd type batteries. They are already used widely in end-user systems and in other grid applications. Batteries are providing energy storage for decentralized grids including renewables. They are essential to a vast range of applications from protecting control and switching systems and supporting UPS (Uninterruptable Power Supply) installations. Batteries are used to improve grid stability by acting as a buffer to compensate for the intermittent nature of renewable energy resources, [53].

Main application areas for these batteries are
dd/mm/yyyy

- Photovoltaic energy systems
- Solar & wind hybrid systems
- Telecommunication networks
- Emergency power back-up and generator starting applications
- UPS

Lithium-ion batteries are expected to contribute to the energy storage in grids due to fast charging, light weight, and high energy density in comparison to their counterparts. Lithium-ion batteries are becoming the energy storage of choice for future electric mobility applications. Foreseen prospects for Lithium-ion technology in larger applications are significantly growing with respect to other electrochemical storage systems and, particularly, in combination with more innovative integration of electricity grids within the transport sector. Sulphur Sodium (NaS) battery systems provide solutions for energy management (peak shaving), reliability (outage) and power quality issues. These applications increase asset utilization, provide alternatives to meet peak demand and improve quality of service. Italy has two NaS battery applications with two 12 MW units and one 10.8 MW unit connected to HV grid. They are used for voltage and frequency control scheme with local and also centralized control. Output power controllability is 0%-100% in charge and 100%-0% in discharge mode and rate of change is 100%/s. In the power factor control, the duration and response time is seconds and rate of change is 1 s. They are used in the balancing power market [53]. Vanadium Redox flow batteries are particularly suitable for large-scale utility applications such as peak shaving, back-up systems and applications coupled with renewables, such as large-scale photovoltaic fields. Vanadium redox batteries also have a short response time and good power density that makes them suitable for Power Quality applications.

Superconductive magnetic energy storage (SMES) systems store energy in the magnetic field created by the flow of a direct current in an inductor realized with a superconducting coil. In normal inductors, current decreases due the losses caused by the increasing coil resistance. Instead superconducting materials have a very low resistivity (of the order of 10-25 Ω). SMES devices are comparatively expensive with parasitic losses and low total energy density. There are still technology challenges especially for the development of larger higher energy SMES systems. High temperature superconductors, more efficient cryogenic cooling systems, high magnetic field and also mechanically secure structure are the key issues in the future development. SMES has high electrical efficiency and SMES system has fast response and capability to control active and reactive power makes its potential to stabilise many smart grid applications. Micro-SMES units address applications such as transmission line stability, spinning reserve, static VAR compensation and voltage support for critical loads.

Supercapacitors can offer advantages over other forms of energy storage. These include long cycle life, high charge/discharge rates, no overcharge, high cycle efficiency, low maintenance costs, reliability, and a rated voltage independent of the cell chemistry. Supercapacitors are in contrast quite sensitive to overcharging. Supercapacitors can perform various functions in electric grids for example: transmission line stability, spinning reserve, phase correction, harmonics suppression, area and frequency control. The characteristics of supercapacitors are the fast response time in milliseconds, high-energy efficiency (more than 95%), high power density and long shelf and cycle life. Various functions can be then performed by SC devices in electric grids, such as, for example:

1. Transmission line stability. The stability of a transmission system by adding energy storage. This serves to dampen oscillation through the successive generation and absorption of real (as opposed to reactive) power. There is also transient stability – the stability required after a utility event (loss of substation or major line). During a transient event, achieving stability

- requires a substantial capability to absorb energy quickly. This is somewhat analogous to “dynamic braking” because generator turbines must be slowed. A typical specification is 100 MW with 500 MJ (< 5 s).
2. Spinning reserve. This is the generation capacity that a utility holds in reserve to prevent service interruptions if a generator fails. An ultracapacitor system can be built to supply power during the interruption, until quick-start diesels begin to supply power. A typical specification is 20 MW to 100 MW and 300 MJ to 1500 MJ.
 3. Area and frequency control. The lack of matching between electrical energy production and energy consumption (including losses) appears as a frequency variation. SC system would be considerably more effective than a generating plant in supplying frequency regulation due to its fast response time. A system based on SC can absorb or supply energy as required, freeing other generation sources from frequency regulation or tie-line control duties. A typical specification is 100 MW to 1000 MW and 0.1 MWh to 10 MWh.

Flywheels have high steady inertia and they can support ancillary services like frequency response, provide short time support for spinning reserves and standby reserves. One module is typically 2 kW - 250 kW. Low speed type flywheels have been used in industrial applications in Poland and their power size has been in the range from 120 kW to 2 MW. They were connected to low voltage and medium voltage networks and used for voltage control. Flywheels have the potential for effectively supporting Flexible Alternating Current Transmission Systems (FACTS) devices to maintain grid stability and reliability but main applications of flywheels in the smaller distributed power systems are for UPS systems. Flywheels in UPS applications typically provide power for 15 - 30 seconds that covers most power quality events and short power shortages. Flywheel systems can work as ride-through power sources with generators and can be used with batteries to cover short-duration events and save batteries that work for longer outages. Flywheel systems with power conversion electronics can serve customers as a controllable and automatic demand-side management option that can provide premium services, including power quality for sags or surges lasting less than 5 seconds, uninterruptible power supply for outages lasting about 10 minutes, and peak demand reduction to reduce electricity bills. For output power control the response time is very short and the rate of change is for example 100 kW / 20 s in the Polish case [53].

3.3.2 Heat and cold storage

Fast-type ancillary services are not directly relevant application areas for typically slow-response type thermal energy storage, but indirectly for example when installed with local CHP systems, thermal energy storage can participate for providing ancillary services. They can also provide ancillary type reserve services for local and district thermal energy production systems. Thermal energy storage can also support blackstart after power outage by shifting the start of HVAC systems. Off-peak electricity can be used to make ice from water. Molten salt storage is used to store heat in solar tower to be used for electricity generation by nights or in non-sunny days. Thermal energy storage can also be used with wind power stations to store energy during low price (low consumption) periods [54].

3.3.3 Pumped hydro storages (PHS)

Pumped hydroelectric storage (PHS) can be pure PHS or pump-back PHS. Pure PHS plants rely entirely on water that is pumped to an upper reservoir from a lower reservoir, while pump-back PHS use a combination of pumped water and natural inflow to produce energy [55].

PHS plants are characterized by long asset life, typically between 50 and 100 years, round-trip efficiencies of 70–85%, fast response time, usually in orders of seconds or minutes. Generally storage system requires less than 10 minutes to get to full capacity, or 10 to 30 seconds within 1 minute if it runs on standby. The discharge time can attain in some installations as much as 24 hours. Pumping and generating can follow a daily cycle, or weekly or even seasonal cycling in larger PHS plant. During long holding times, there are almost no losses in the storing process, which enables long-time scale storage. The storage capacity can attain several gigawatts. The storage power is dependent on the reservoir capacity and the head. As well known the hydraulic power available is proportional with flow and head. The energy available is dependent of how long time before the reservoir is empty. The average plant size in the EU-27 is about 270 MW, with the largest pumped-storage facilities being Grand'Maison plant located in Isère in France and the Dinowig power station in Wales, United Kingdom, developing each about 1800 MW (EC, 2009).

Response time is dependent on mainly two time constants, the inertial time constants of rotational masses and the time constant for the hydraulic inertia. The first one is dominated by the generator and is usually of the order of 6 seconds. The hydraulic inertia is approximate 1 second, which is more or less a design criterion. The result is that the hydropower plants will stabilize at approximately 10 s.

Dinorwig Power Plant in UK:

- | | |
|---|-------------|
| • Auto-start, synchronize and load to 150MW | 125 seconds |
| • Generate normal step load change 150MW-250MW | 6.5 seconds |
| • Emergency response from spin-generate to generate 150 MW in | 8.5 seconds |
| • Emergency response from 150 MW generate 70 MW in | 4 seconds |
| • Pump to spin-pump | 95 seconds |
| • Generate 200 MW to spin-generator | 11 seconds |
| • Spin-pump to pump | 41 seconds |

In normal operation Dinorwig pumped storage plant in UK, Wales can regulate 100 MW in 6.5 seconds, which equals 923 MW/min. The emergency response equals 2250 MW/min, while traditional hydro power plants will have trouble with meeting 200 MW/min.

PHS plants offer a significant technology base for regulation and can accommodate variable electricity generation. The main applications for hydropower storage are wholesale arbitrage and peak power capacity, energy balancing, the provision of tertiary and secondary reserves, forecast hedging, transmission curtailment, time shifting, load following etc. PHS can provide both up and down regulation and can assist with frequency regulation and voltage control. Due to quick start capabilities, PHS can provide black starts and provision of spinning and standing reserves. They are most suitable for transmission application rather than distribution. PHS plants are also used for seasonal fluctuations, being capable of providing hundreds of megawatts for many hours at a time. The Vattenfall Goldisthal PHS plant in Germany, for example, which was commissioned in 2003 with a capacity of 1060 MW, is currently used for load management (intertemporal arbitrage) and for ancillary services (secondary and tertiary reserves and black start).

With regard to the future trends the technical potential of new pumped hydro plants in Europe is very low, due to the high potential impact on the environment and to the necessity of an adequate altitude profile and geology. It is estimated that about 75% of the total potential for hydropower has already been developed in Europe. By 2030 more than 50% of the present installed capacity of hydro storage in Europe will have to be refurbished in any case due to aging. The capacity of hydro reservoirs in Europe is estimated to be approximately 180 TWh, of which, the Norwegian hydro reservoir capacity accounts for about 50% (84.3 TWh). The large hydropower capacity of Norway

already supports the need for flexibility and storage of its neighbouring countries. The large deployment of wind power in the North Sea drives to the exploitation the Norwegian hydro power potential. This necessitates the establishment of grid connections with Germany and the UK, and the reinforcement of the existing connection with the Netherlands. Tables 10-13 show the typical pumped hydro power characteristics.

Table 10: Typical pumped hydro power size and connections to grid.

Country	Typical unit size	Connecting grid level	Type of communication channel	Availability of control functions
Austria	Total 112 with 7847 MW; <10MW 45 plants with 154 MW; <1MW: 9 plants; 1 - 2.5 MW: 14 plants; 2.5 - 5 MW: 11 plants; 5 - 10 MW: 11 plants; >10MW: 67 plants with 7693 MW; 10 - 20 MW: 16 plants; 20 - 30 MW: 10 plants; 30 - 40 MW: 5 plants; 40 - 50 MW: 4 plants; 50 - 80 MW: 8 plants; 80 - 100 MW: 3 plants; 100 - 200 MW: 7 plants; 200 - 300 MW: 7 plants; >300MW: 7 plants	typically <10MW MV or HV for bigger plants	Fixed fibre connection for large and medium size plants. Currently: IEC 60870-5-104 is a common approach in Austria to control the power system. Future: It is expected that the IEC 61850 will play a more important role in Austria for controlling power plants. In detail, the IEC 61850-7-420 (Hydroelectric Power Plants - Communication for monitoring and control) should be applied for monitoring and control purposes. Balancing market: Currently: Only protocol IEC 60870-5-101 is allowed (all balancing markets FCR, mFRR, aFRR). Only point-to-point connection, no Ethernet.	voltage and frequency control
Greece	2 plants 315 and 384 MW	HV	Continuous availability and wired (fibre-optic) communication channel	Continuous
Poland	There are 20 units in 7 pumped-storage power plants, among them: P = 135MW-179MW; 8 units, P = 28MW- 68MW; 12 units (power of	Two pumped-storage power plants (4x135MW and 4x179MW) are	Fixed fibre connection for large and medium size plants.	Frequency and voltage regulation

	generation has been given).	connected to EHV, the rest to HV.		
Portugal	1036 MW (Total)	EHV/HV	Fibre connection	
United Kingdom	Depends on generation technology used.	HV	-	Voltage and frequency control

Table 11: Availability of control for pumped hydro power.

Country	Voltage control scheme used	Frequency control scheme used	Flexibility for control scheme and parameter changes	Possibility of simultaneous provision of these functions [describe]:	Availability for control
Austria	local or centralized control depending on plant size	Yes, local or centralized depending on size and type FCR, aFRR or mFRR;	Yes	Yes.	Continuous, but depending on water reservoir
Greece	Local	Local	Yes, via remote connections	Yes. Synchronous generator: voltage regulation by excitation, and frequency regulation by rotating speed of turbine	
Poland	Local fast control of voltage set value, set points coordinated on area	Local fast control, set points coordinated on area	Parameters can be changed on site, mode control and set points can be changed remotely.	Synchronous generator: voltage regulation by excitation (Voltage Control and Excitation System), and frequency regulation by rotating speed of	Typically: 4÷5,5 hours of maximum power generation and 6 hours of pumping

				turbine (Governor)	
United Kingdom	-	Centralized	-	-	Fast reserve: resource is expected to be available within close proximity to last utilization

Table 12: Output power controllability for pumped hydro power.

Country	Output power controllability	Constraints of controllability	Duration of control	Rate of change	Response time
Austria	For upwards regulation (only pumped storage): 0% 1 synchronous pump turbine; 7 0-100% 1 asynchronous pump turbine; 0-35% 2 synchronous pump turbine with hydraulic bypass; 0-60% 1 conventional mechanical pump and turbine set with hydraulic bypass; 0- >90% best case e.g. Kops II; For downwards regulation: 100-40% 1 synchronous pump turbine; 100-35% 1 asynchronous pump turbine; 100-20% 2 synchronous pump turbine with hydraulic bypass; 100-40% 1 conventional; 100-10% possible for best Case e.g. Kops II; mechanical pump and turbine set with hydraulic bypass;	Depending on available reservoir, state (stop/consumption/generation)	Continuous for several hours, depending on reservoir		Sec; Stop - full generation: 60-90s for conventional mechanical pump and turbine set / 100-150s for pump turbine; Stop - full consumption: 80-110s/ 250-400 sec; Full generation - full consumption: 80 – 110 s/ 450-700 s; Full consumption - full generation: 40-120s/ 75-100s
Greece	100 %	Water reservoir levels	From minutes to hours		s

Poland		For the sake of optimal technical operation condition units generate maximum power (recomended) depending on water level, start (typical) 1-2 minutes.	Max some hours, depends on water in reservoirs	nominal power in ca. 5 sec	seconds
Portugal	For upwards regulation: N.A (only participates in downward tertiary control): For downwards regulation: downward tertiary control		60 minutes (maximum)	Upward reserve power divided by 5 minutes (e.g., power plant of 10 MW shall guarantee a 2.5 MW/min rate of change)	seconds
United Kingdom	For upwards regulation: minimum contracted capacity of 3MW for short term operating (STOR) reserve and 50MW for fast reserve (FR)		FR: 15min STOR: 2 hours	FR: 25 MW/min and maintaining 50MW for duration of control. Ramp down at a similar rate. STOR: minimum contracted capacity within response time.	FR: within 2 minutes of instruction. STOR: within 240 minutes of instruction.

Table 13: Power factor controllability for pumped hydro power.

Country	Power factor controllability [cosφ limits]:	Constraints of controllability	Duration of control	Response time
Austria		0.9 for plants <13.8 kVA required and possibility to define default value; possibility to up to 0.75	continuous, depending on reservoir	seconds
Greece	0,7-0,85* (cap./ind.) *0,4ind. for <35% loading		Continuous	seconds
Poland	0,88cap0,98 cap ÷ 0,85 ind0,88 ind (cap/ind – in convention of generation)	Generator capability curve	Max some hours, depends on water in reservoirs.	Static exciter: less than 1 min

According to the National Roadmap-2050 report in Greece, in order to fulfil the RES development targets, about 1 GW of PHES capacity is required by 2020 and 2 to 5 GW up to 2050, depending on the scenario. In Poland, no new pumped-storage power plants are planned till 2030. The share of total nominal power of pumped-storage power plants run- of total installed capacity amounts to 5%. Pumped-storage power stations are able to generate maximally 1788 MW for 4 hours. Efficiency of pumped-storage power station is ca. 75%. Portugal is expected to increase the total pumped hydro capacity for 5052 MW by 2030. With regard to UK, with increasingly lower system synchronous inertia (due to renewables connection) and closure of fossil fuel generation plants, National Grid will require more of these services to maintain system security. National Grid foresees a greater role for interconnection in providing flexibility with estimates of 7-11GW worth of interconnection in 2030 (that is around 6.3-10.7%) of total installed generation capacity [56...58].

3.3.4 Other types of storage

Compressed air energy storage (CAES) systems are a hybrid form of storage that is used for large-scale energy storage. The underlying principle of CAES is to rely on the elastic energy of air to store electricity for later expansion, which generates power via a natural gas turbine. The economic and technical performance of CAES plants is expected to continue to improve. The large size of CAES technologies (50-300 MW of energy) and their fast ramping rates (several minutes) make them suitable for system applications, such as load following, frequency regulation and voltage control. One feature of a new generation of proposed CAES plants is that they may be closely integrated with wind farms, representing a means of storing additional power generated off-peak.

Another form of energy storage based on air (or nitrogen) is liquid air energy storage (LAES) or cryogenic energy storage. LAES works similarly to CAES however the energy is used to cool the

air until it liquefies in order to store it in normal pressure conditions. Liquefied air takes about 1/1000 of ambient air's volume. Next, when energy is needed, liquid air is pumped at high pressure to a heat exchanger, which acting like a boiler is used to drive a gas turbine. Commercial LAES systems are available in sizes ranging from 5 – 100 MW and 15 – 250 MWh with the target efficiency at around 60%.

3.4 Other flexibility resources

3.4.1 Static compensation devices

Currently there are quite a few static shunt compensation devices operating in EHV and HV grid (both capacitive and reactive). The source of reactive power is either a reactor or capacitor. The typical unit size is around 15 MVAR, whereas max is 50 MVAR. Typically they are connected to tertiary winding of 220 or 400 kV/110 kV transformers, and operating at MV level. Some of them are also connected to 110 kV and 220 kV voltage level. Their main goal is to maintain desired voltage level by feeding the grid with necessary reactive power. They are controlled by switch, so they can operate either at their nominal power, or switched off. The control signals come either from local station SCADA system, or from TSO/DSO dispatching centre. Control functions are maintained by station group voltage regulation system that controls both transformer tap changes and static compensation devices.

There are few directions in which these devices can evolve in 2030 time horizon. One would be increasing their number, as well as nominal power. It will enable to fulfil their main aim (which is maintaining voltage in an allowable level) in wider range of situations and grid operating conditions. This is the way they evolved historically. Another direction of evolution for static compensation devices would be shift from mechanically (switch) controlled to electronically (thyristor) switched devices. This change will enable them to not only regulate the voltage level but also dynamically respond to grid operating state. The main advantage of thyristor switched devices over simple mechanically-switched is their near-instantaneous response to changes in the system voltage. Most of the currently installed devices (both reactors and capacitors) can be updated to thyristor switched ones and thus create either TCR - Thyristor Controlled Reactor or TSC - Thyristor Switched Capacitor.

The only present drawback of TCR and TSR is that they are more expensive than mechanically switched compensation devices. A combination of the two technologies (even in the same installation) can be utilized. In this case static VAR compensators are used to provide support for fast changes and the mechanically switched ones are used to provide steady-state reactive power compensation, however a lot of attention has to be put into optimal selection of device's location to be upgraded to TCR or TSR.

3.4.2 Static compensators (STATCOM) and other FACTS devices

FACTS (Flexible AC Transmission Systems) are power-electronics-based devices that are able to influence such parameters of AC system as impedances (shunt and series), current, voltage, phase angle and power flow. They are very effective in power flow control, voltage control, oscillation damping on various frequencies, voltage and transient stability improvement and etc.

Depending on the technology used in a particular device, both static and dynamic properties will be different. For the two most popular solutions, i.e. SVC and STATCOM, differences in static

characteristic mean different achievable operational range in QV plane, wider and less dependent on PCC voltage for STATCOM. Also in terms of dynamic performance, i.e. time response and stability of control STATCOM is superior to that offered by SVC, being approximately three times faster and more robust against system condition changes. In fact, the performance of both of these static compensators is highly dependent on system impedance, which continuously varies, and thus worst case response time is typically in the range of 30 – 80 ms. Typical rated power of a FACTS device can be as high as a few hundreds MVAR, with almost symmetrical division into capacitive and inductive range. Usually, they have been installed in the HV transmission networks, but nowadays more and more often they are also present in the distribution systems, since (distributed) generation is also there and due to its volatile nature it needs support from flexible resources.

With great flexibility boost in the power system comes considerable cost of a FACTS device, thus a lot of attention has to be put into optimal location search for such a device. The selected location can often be optimal only for a set of the most critical or the most frequent grid conditions and contingencies, but not for all. A future, emerging concept improving this situation is a distributed flexible AC transmission system (D-FACTS) device. These modular, simple, cost and space saving devices can perform similar tasks to their lumped counterparts, however the impact of their action can be more widespread and equally distributed. A main representative of D-FACTS group is a DSR (Distributed Series Reactor), which can address some of the typical system expansion problems like congestion, flow control and etc. Currently it is the only commercially available D-FACTS device, however others are developed with D-STATCOM being in main focus.

3.4.3 Synchronous condensers

Synchronous condensers have already been known and used in the power system for more than a hundred years and after a few decades of reduced interest in favour of their power electronics counterparts, namely SVC and STATCOM, they now regain the attention, primarily as dynamic reactive power devices, and additionally due to synchronous inertia and short circuit power provision. Unit size can extend from a few tens of MVARs for industrial applications to several hundreds of MVARs in power system use, both as new dedicated units and conversions of synchronous generators of the phased-out nuclear power plants.

The main reason for synchronous condenser installation is reactive power output and/or voltage stabilisation. For conditions or contingencies including low voltage, SVC will perform much worse, as its reactive power output decreases in square with voltage. Synchronous condenser and STATCOM have better performance in this respect since reactive power decreases proportionally to voltage. The distinguishing feature of a synchronous condenser is its overloading capability allowing to keep the reactive power output constant for a few seconds when the voltage drops down. Another difference is that like any rotating machine, synchronous condensers inherently and constantly provide inertia support, which is of special importance in smaller (islanded) systems with high RES penetration. On the other hand, STATCOMs can also be controlled in a way that virtual synchronous inertia is obtained, but this is subject to time and magnitude limits.

3.4.4 Cross border connections

Cross-border connections enable each single power system to constitute a part of a large interconnected power system thus improving operational stability and economic efficiency. They are also a prerequisite for pan-European electricity market and allow for market coupling. There

are two types of the interconnections with respect to the power balance, i.e. connections between countries but inside the interconnected power system, which do not change the power balance (neglecting the losses) and connections reaching outside of the interconnected power system, which provide surplus energy or load to the system. Regarding the technology used, cross-border connections can be both AC and DC.

AC interconnections are predominant means for cross-border connections within a synchronously operating power system. Power transfer via AC lines depends only on the laws of physics and properties of lines thus does not require any additional equipment or control; what is more, AC lines provide means for active power auto-balancing and frequency control since they inherently transfer information on voltage frequency.

Cross-border connections based on AC lines can also be used for interconnections between asynchronously operating power systems. In this case AC line forms a radial connection stretching out from one power system to another and is often used to import energy from a power plant that is isolated in the external power system.

However, for the purpose of asynchronous system interconnection DC technology is used much more often. HVDC technology is one of the fastest growing branches of the power industry introducing new technology breakthroughs every year. Currently maximum transfer capacity for a point-to-point interconnection is 8000 MW for 800 kV classic Line Commutated Converter (LCC) type and 1000 MW for 320 kV Voltage Source Converter (VSC) type (525 kV has been released recently and has not been used yet). A single connection can be as long as 2000 km for LCC and 450 km VSC. Larger distances are economically unjustified due to high conduction losses, for which the foreseen solution is to increase the DC voltage.

More and more often HVDC technology is used for cross-border connections inside the interconnected power system, creating so called embedded HVDC converter schemes. It is chosen instead of AC lines due to the ability to transfer more power with the same right-of-way, for bulk power transmission or AC reinforcement and, more importantly, due to its superior controllability. Examples of the projects under construction or in planning are Inelfe (Spain – France), ALEGrO (Belgium – Germany), South-West Link (Sweden – Norway) and electricity highways in Germany. Another step in HVDC technology development and utilisation consist in increasing the number of converter stations in one scheme (multi-terminal HVDC) and, more futuristically, interconnecting many point-to-point links to form a DC grid. There are still however many obstacles, especially in the latter concept, e.g. tackling short-circuits in DC circuits (lack of DC breakers), operation and dispatching problems, multi-vendor coordination and etc.

Both LCC and VSC exhibit full controllability of active power during normal operation, however reactive power behaves differently depending on the type of the converter. In thyristor converters reactive power is proportional to active power and usually filters are used in order to assure limited exchange of reactive power with external AC system. On the other hand, converters based on IGBTs are able to control reactive power in the same manner as active power, respecting limits dependent on present voltage level and short circuit power.

Cross-border connections based on HVDC converter schemes can play an important role in frequency and voltage support. Irrespective of the type of HVDC link each scheme can be equipped with a supplementary control loop which adds to the scheduled power order a signal ΔP resulting from frequency control loop or power oscillation damping loop operation. Voltage support is really offered only by VSC type HVDC links since VSC converter station has inherent STATCOM capabilities and can take part in independent (from active power level) reactive power or voltage control. Settling times of power control (current control) loop can be as small as 100 ms for LCC

type and 10 ms for VSC type, however the operational practice is to change power via slower ramps (MW/min) in order not to cause disturbances in the power system and fast regulation is only used for emergency power control (EPC) action.

In contrast to HVDC, AC cross-border connections have no inherent control capability. However, it can be improved by utilisation of FACTS devices, especially series or shunt-series type, such as TSCS, SSSC, UPFC or by slower-acting phase shifting transformers.

3.4.5 Tap changing transformers

Tap changing transformers provide a means of voltage control, typically in the range of $\pm 10\%$. It enables transformer linking networks at different voltage levels to keep the voltage in the required range, while undesirable voltage fluctuation usually caused by system load changes. Ratio adjustment is performed by changing the number of windings turns in the transformer either on the primary or the secondary winding. Number of turns is stepwise changed through the taps. This gives a step regulation of the transformer.

From point of view of tap changing facilities transformers can be divided into two groups:

- ULTC – *under load tap changing* transformers (also called *on load tap changing* - OLTC or *load tap changing* - LTC) – which allows the taps to be changed whilst the transformer is energised – under load without interruption.
- *Off-load tap changing* transformers (*No-Load Tap Changer* - NLTC, *off-circuit tap changer*, or *De-Energized Tap Changer* - DETC) – the tap changer requires to be de-energised whilst tap changing take place.

A transformer may include a tap changer on each winding, for example, in distribution networks, a large step-down transformer may have an off-load tap changer on the primary winding and an on-load automatic tap changer on the secondary winding or windings. In practice, mainly for economic reason, changing the number of turns is performed on one side of the transformer. Because of lower current, the taps are usually situated on the high voltage side of the transformer and near the neutral end of the winding, where voltage with respect to ground is the least. In autotransformers taps are also on the high voltage side but near common part of the winding.

Off-load tap changing transformers are commonly used in distribution MV network, where tap is usually changed manually seasonally (e.g. twice year).

The ULTC transformers operating in EHV and HV substation are supervised by substation transformer control system within the scope of:

- maintaining the set (reference) voltage level at transformer substation busbars,
- maintaining the set value of reactive power flow through a transformer,
- turn-ratio control of a transformer.

The tap selection in under load tap changing transformers is automatic and controlled by assigned an individual regulator that typically can operate according to one of the following four regulation modes:

- voltage control on switching substation busbars at higher-voltage side of a transformer,
- voltage control on switching substation busbars at lower-voltage side of a transformer,
- control of reactive power flow through a transformer,
- turn-ratio control of a transformer.

The ULTC can be classified as mechanical, electronically assisted, or fully electronic. The tap selection in mechanical under load tap changing transformers operate by motors. The mechanical tap changer physically makes the new connection before releasing the old one using selector switches. To avoid creating high circulating currents a diverter switch to temporarily place a large diverter impedance in series with the short-circuited turns is used. Such motor-based ULTCs are characterized by a slow time response (tens of seconds) and low operating speed, short lifetime and heavy size. In order to improve these properties, two technologies are used: electronically assisted and solid-state ULTCs. Both technologies are inherently faster than the motor-based one. However, the differences in the model are mainly in the low-level logic of the electronic switches. These solutions prevents problems with open or short-circuit turns.

Electronically assisted tap changers are based on thyristors, which take the on-load current while the main contacts changeover from one tap to the next. This prevents arcing on the main contacts and lengthen lifetime and period between service and maintenance activities. This solution is more complex and requires a low voltage power supply for the thyristor circuits. The most recent solution is a solid state tap changer, which use thyristors both to switch the load current and to pass the load current in the steady state. Comparing to others solid state tap changer are smaller. A disadvantage of this solution is less efficiency of the transformer, what is connected with leakage current of the non-conducting thyristors connected to the unselected taps. The lost power transformed to heat has to be removed from the device. Solid state tap changers are typically applied on smaller power transformers.

For the time being, no alternative to regulating transformers is expected. What is more, a possible way of controlling the voltage in LV distribution grids is by means of on load tap changer of a MV/LV transformer (ULTC MV/LV) in a similar way of how it is currently done for MV grids with HV/MV ULTC will be developing. The tap-changer will therefore continue to play an essential part in the optimum operation of electrical networks and industrial processes in the foreseeable future. Conventional tap-changer technology has reached a very high level and is capable of meeting most requirements of transformer manufacturers. This applies to all the voltage and power fields of today, which will probably remain unchanged in the foreseeable future. It is very unlikely that, as a result of new impulses to development, greater power and higher voltages will be required. Today, the main concern focuses on service behaviour as well as the reliability of tap-changers and how to retain this reliability at a consistently high level during the regulating transformer's life cycle. Today's design concepts of ULTCs (both resistor and reactor-type) are based more and more on vacuum switching technology, in fact is the state-of-the-art design of today and tomorrow. The proper implementation of vacuum switching technology in ULTCs provides the best formula for quality, reliability, and economy that can be achieved for maintenance-free design in the field of ULTCs.

A further level of complexity can be added with the possibility of tapping the 3 phases independently and in an asynchronous way. The ULTC type is normally divided into 3-phase ULTC where the ULTC has the commonly winding on three phases and 3 single-phase ULTCs where the ULTC has the winding on each phase (for simplicity, 3 single-phase ULTCs is named 1 phase ULTC afterwards of this report). The ULTC changes the ratio of a transformer by adding or subtracting to and turns from either the primary or secondary winding. Specifically, DTU is carrying out a Danish EUDP project 'Energy saving by voltage management' [59] which aims for verifying the benefits of the 1 phase ULTC transformer in presence of unbalanced load or PV connections.

The main conclusion of the simulation study shows that power distribution transformer with 1 phase ULTC control significantly improves the PV hosting capacity in the analysed unbalanced scenarios without side effects [60].

3.4.6 Phase shifting transformers

Phase shifting transformers are specially designed transformers for the purpose of changing voltage angle. When installed in series with a line or a transformer they can effectively control power flow in this element by changing voltage phase angle on one of the ends and thus

$$P = \frac{U_1 U_2}{X} \sin \delta \quad (1)$$

changes. For this reason they are often installed in cross-border AC connections allowing for line overloading reduction and stability improvement. PSTs are installed on borders between Germany and Belgium, Germany and the Netherlands, Italy and Slovenia and are under construction between Germany and Poland.

With respect to PSTs' controllability, maximum phase shift $\pm\alpha_{max}$ is the main parameter characterising available control range. α_{max} is typically in the range of $20^\circ - 40^\circ$. Resulting power flow change depends on network voltage level (EHV/HV) and the present power flow conditions in the power system; for instance it can be in the level of 10 – 30 MW/deg for 400 kV network. The objective of the PST operation is to control the power flow in the tie lines in the medium-to-long term operation so the time regime for tap-changing operation is rather low. It takes 30 – 60 sec. for a tap to change and the following power change is immediate.

Example from Poland shows that phase shifting transformers are going to be an effective solution for congestion problems caused by excessive renewable (uncontrolled) generation. Where other means failed (e.g. redispatching generation, DC loop flow and switchyard coupler opening), PSTs are promising option and therefore their development and wider utilisation is likely, particularly in prospect of further RES integration.

3.4.7 Frequency transformer

A device functionally surpassing a phase shifting transformer, both with respect to construction and operation principle, is a variable frequency transformer (VFT) [111, 112]. It is a controllable, bidirectional transmission device based on a rotating doubly fed induction machine, used for connecting asynchronous systems, where one system is connected to the stator windings and the other to the rotor windings. Power flow controllability is accomplished by use of a mechanically coupled DC motor and proper torque control of on the common shaft. In comparison to PST, VFT can connect grids of different system frequency, has wider on-load phase angle control, no power control dead band, faster response and no tap-changing mechanism. Its first commercial deployment took place in 2004 (a 100 MW unit), and there are several examples of field deployment but only few of planning studies in the literature. This is caused partly by the functional similarity between VFT and back-to-back HVDC and better characteristics of B2B HVDC with respect to response and recovery time. On the other hand, B2B HVDC produces harmonics which have to be filtered out by separate large devices, whereas VFT produces none and therefore needs no filters at all[114-117].

4 Abstractions for modelling interactions across control boundaries

The scope of this section is to approximate appropriate models that characterize the interactions under normal and emergency situations, introducing suitable data rates and models for use by real-time control functions. This section starts by presenting the fundamental concepts that govern the operation of the present electricity networks. These concepts are applied both to frequency and voltage control of the present electrical network and executed/applied locally or remotely. These operating and control principles through appropriate modifications or adjustments are envisaged to also dominate the operation of the future electrical networks.

The trend of increased growth of decentralized (mostly renewable) electricity production lends itself to a decentralized approach for frequency and voltage control. Thus, local distribution grids will play significant role in the resolution of voltage and frequency issues. Considering that in future, the generation units will be mainly small renewable resources (which until now are not designed for directly frequency and voltage control), it is believed that new strategies and techniques that affect the flexible and economic electricity production and demand are needed. Thus, some strategies that are believed to play a particularly important role in the operation of the future electrical grids are presented next.

Trends from WP3, WP4, WP5 and Subtask 6.1.1, the current practice of observing Transmission and Distribution networks, as well as the following documents [60-71] were used as a basis for collecting relevant information and formulating the nature of future interactions between entities involved in a flexibility market

4.1 Identification of control boundaries within the European Electricity Networks

In the European Electricity Networks two forms of control can be observed. Frequency Control and Voltage Control. The boundaries of these control types extend over the European level, regional level (neighbouring electrical grids), national level, local, etc. Boundaries are affected by the electrical grid structure, the demand and generation characteristics and the market. In future electricity networks the boundaries should be defined through more sophisticated structures that base their operating principles on structures such as the micro-grids and the smart-grids.

4.1.1 State of the Art in Frequency Control and Regulating Reserves

Frequency Control and the corresponding regulating reserves have to keep the balance between demand and supply of electricity. The frequency Control can be seen as a global quality criterion for real-time power and energy balances. Disturbances depending on generation units operation, the availability of power resources, changes in the demand and real-time behaviour of third parties and grid customers cause the system frequency to deviate from its set value, which can affect the behaviour of electrical equipment and may lead to protective disconnection of generation units and eventually a system black-out in the case of large deviations. Imbalances between demand and supply of electricity are initially offset by the rotating generating sets and motors connected to the system's kinetic energy (system synchronous inertia). System synchronous inertia can only slow down frequency deviations and is not in the least able to restore the power balance.

For this reason TSOs procure balancing services, called Frequency Control Reserves (FCRs), in the balancing or real-time market . FCRs compromise an essential part of Ancillary Services (AS) and consist of primary, secondary and tertiary control reserves. In general terms, the Primary Control Action taken within 5-30 seconds by generators droop control. Secondary Control resets the primary control reserves in 5-15 min in order to be ready for the next disturbance and the Tertiary Control restores the Secondary control reserves, manage eventual congestions, and bring back the frequency and the power exchange programs to their target, if the secondary control reserve is not sufficient. Next, figure 4-1 summarizes the current framework for frequency regulation within the European Electricity Networks.

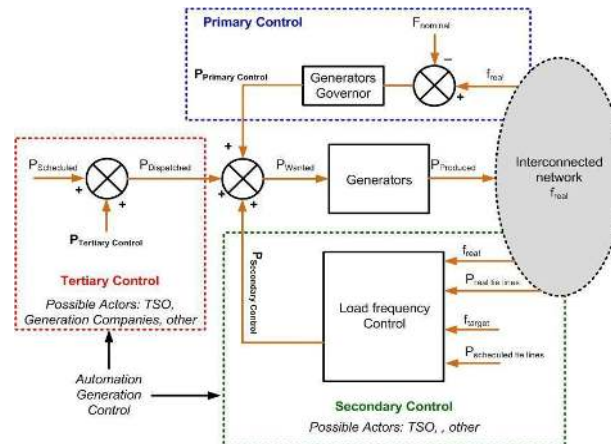

Figure 2: Current framework for frequency regulation within the European Electricity Networks, [65].

Primary Frequency Control

The objective of Primary Control is to maintain a balance between generation and consumption within the Control Areas/Blocks. By the joint action of all interconnected parties, Primary Control aims to ensure operational reliability of the Controlled Area and stabilises the system frequency within a band around a setpoint, static setpoint, or dynamically set after a disturbance or incident in the time-frame of seconds. Primary control has no capability of restoring the frequency and the power exchanges to their reference values. Adequate primary control depends on generation or load resources made available to the cell operator.

Secondary Frequency Control

Secondary Frequency Control (SFC) maintains the balance between generation and demand within each Control Area/Block and keeps the frequency within the allowable limits that may be within a band around a setpoint, static setpoint, or dynamically set. The SFC should take into account the Control Program and should never degrade the performance of the Primary Control that is operating simultaneously in the Synchronous Area . The activation of SFC Reserves is performed automatically. In order to achieve SFC, the local controller should measure the Control Error (by measuring the appropriate observable signals and send control objectives (active power set points) to Secondary Control Reserves (adjustment of generation sets). SFC reserves should reset the primary control reserves in 5 –15 minutes to be ready for a subsequent disturbance. Adequate Secondary Control depends on generation resources made available by generation companies to the system operator, independently from Primary Control Reserves

Tertiary Frequency Control

In a balanced system situation, the Tertiary Frequency Control (TFC) is mainly used to release the SFC Reserves by triggering the Replacement Reserves (RRs). Moreover, it is also possible to activate supplementary Frequency Restoration Reserves (FRRs) after larger incidents in order to restore the system frequency and consequently free up the system wide activated Primary Reserves. Tertiary control ought to ensure power balance within a control block/area in a longer duration that complements that of Primary control and SFC. The time frame, in which the RRs' activation and operation takes place, ranges from minutes to hours. In particular, the activation of RRs is limited within 15 minutes from the disturbance while they can remain active even after this interval (e.g. for 1 hour). Although, nowadays TFC Reserves are usually activated manually by the TSOs. In the web of cells concept (to be presented in section 4.5.3), TFC may be activated automatically. In the near future the diversity of resources that can be used as Restoration Reserves will be quite extensive mainly due to the increasing number of DERs at the distribution level.

The above Frequency Control scheme is assumed effective, as far as the power system follows the traditional centralized configuration as illustrated in Figure 3. According to this configuration the demand is passive and uncontrollable and does not contribute actively to the operation of the system.

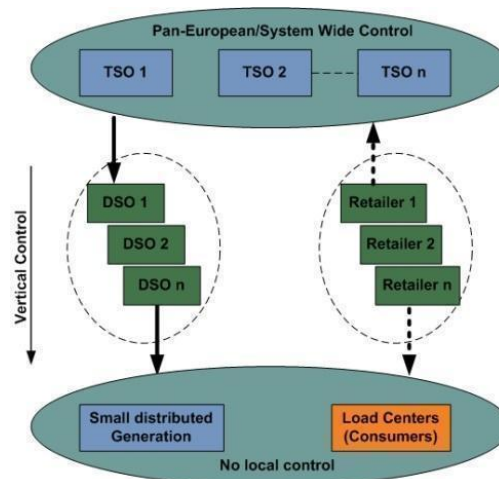

Figure 3: Traditional centralized Power system configuration with vertical control capability.

The TSOs keep the power balance on a second to minutes time scale by monitoring the electric system frequency, while the generation schedules are pre-defined on a day-ahead market and may further be adjusted on intra-day and regulating power markets, where available. DSO's distribute the power coming in from the transmission grid to their load centers, where local constraints to transmit ample power are indicated by the deviations from nominal voltage in the involved substation nodes of their distribution system. Thus, the power system is controlled vertically by TSO's and DSO's. Moreover, TSOs are able to keep the power balance since they control the majority of the total generation in the system. Relatively small distributed generation (e.g. 10% in total) in or near the load centres has little influence on the day-ahead prediction of the system load, and therefore little effect on the overall power system control and stability.

More recently, the power system complexity has been increasing mainly due to the widespread use of DER (mainly in LV and MV grids). Thus, many frequency deviations (close enough to the design limit for primary control reserve) not only at hour boundaries have been observed. These frequency deviations at hour or half hour boundaries appear due to fact that generation follows market rules which anticipate the necessary energy and does not consider the real time load

demand and can be predictable. On the other hand frequency deviations at random time points may reveal a short-time mismatch between load and generation due to rapid DER plants output power in case of electrical grids with high DER penetration. These continuous system frequency deviations involve the activation of ancillary services such as e.g. primary and secondary reserve, and increase end-users final electricity prices. Under specific situations the gradient of these frequency drops may be higher than 1.5 mHz/s which is comparable to outage conditions.

4.1.2 State of the Art in Voltage Control and regulating Reserves

Generally, the Voltage levels in an electricity network are maintained by reactive power generation provided by different facilities. The voltage value depends on network topology, generation and loads unbalance, as well as on physical limitations such as transmission line capacity and transformer loading. Depending on the operational state of electricity networks, the energy generation units, the consumers as well as system components such as lines and transformer, consume or produce reactive power. Nowadays, in order to compensate an immoderate consumption of reactive power, TSOs have to ensure that some producers feed sufficient reactive power efficiently into the networks.

Contrary to the active power, reactive power cannot be transmitted over long distances efficiently, since the transmission of reactive power causes an additional demand for reactive power in the system components and thus an extra voltage drop is generated. In order to maintaining an acceptable voltage level and allowable voltage deviation within predefined limits, reactive power generation and consumption have to be situated close to each other. Thus voltage control is primarily a regional problem, which may involve several TSOs in an interconnected system.

Proper voltage levels, close to their rated values, are necessary for correct, safe and efficient operation of power systems. Too low or too high voltages may cause consumer equipment, if not disconnected earlier, to malfunction, be damaged or manifest properties that are very undesirable regarding secure system operation. The same applies to the components of transmission and distribution systems. In turn, if voltages are in their prescribed ranges then usually there is some headroom for their optimization to minimize losses.

Requirements for voltages involve not only their levels in very different conditions of system steady state operation but also their behaviour during transient conditions. For instance faults should not cause deep wide area voltage depressions and after fault clearance voltages should quickly return to their pre-fault values.

All the mentioned aspects of maintaining proper voltage require voltage control which can be realized only when there are regulated sources of reactive power with sufficient reserves and when considering transient condition requirements, part of these sources is able to provide reactive power rapidly. Therefore system voltage control is inseparable with reactive power management. It should be noted that the network itself especially EHV lines dependent on their loading can be a reactive power source or sink.

Other than in the case of system wide frequency regulation the voltage regulation and reactive power management are characterized by area limitations due to the inability to practically transmit reactive power over long distances. The limitation depends mostly on the network characteristics – in a stiff meshed network the voltages are much more uniform and reactive power transfer is more efficient than in a weak network. It means that in the stiff network a control of one selected bus

voltage may be sufficient while in a weak widespread network one could need more controls responsible for voltages in some pre-determined network zones.

Reactive power sources necessary for voltage control are mostly allocated to transmission networks. The most important sources are large synchronous generators with AVR which have the ability to provide or consume reactive power very quickly (often less than a hundred milliseconds) and over a wide range. Therefore synchronous generators with AVR have the main responsibility for voltage levels and voltage behaviour in transient states.

Referring to the regulation speed and range, synchronous condensers, SVCs and STATCOMs have similar characteristics as synchronous generators. Their rather limited using in today's networks is due to economic reasons – fast voltage regulation and some other features like improvement of power quality and damping are usually not sufficient for economically viable installations of such devices.

Beside synchronous generators the commonly used controllable sources of reactive power in transmission systems are mechanically switchable shunt devices – reactors and capacitors (MSC). Achievable voltage regulation from these devices is not continuous and slower (seconds) than that from synchronous generators. Network switching operations, especially in case of lightly loaded EHV lines are used as a voltage regulation measure by some TSOs.

From the voltage regulation perspective the distribution network is usually a stiff and meshed network where adequate voltage profiles can be achieved by regulating voltage at only one bus which is normally the bus supplied by an EHV/HV (or HV/MV) transformer with a controllable tap changer. In some cases the tap changer regulation is complemented by mechanically switched capacitors and/or reactors. In order to maintain the right voltage profile, energy-intensive consumers are ordered to maintain their power factor in predefined values (keep proper balance between reactive and active needs).. Also generators in distribution networks are commonly obliged to maintain a specific power factor.

Area limitation for voltage control and different speeds of reactive reserves provisions are the reasons why power system voltage regulation is realized in a hierarchical scheme which consists of three layers: fast primary voltage regulation (PVR), slow secondary voltage regulation (SVR) and much slower tertiary voltage regulation (TVR). PVR is always present; SVR and TVR are becoming more common in modern power systems. Time and spatial separation between involved regulations allow for using the scheme presented in Fig.4.

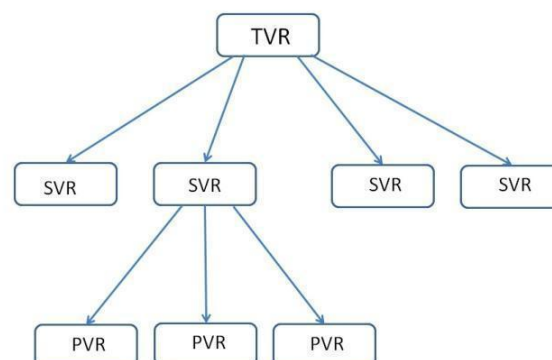

Figure 4: General Voltage regulation scheme in nowadays large power systems.

Primary Voltage Regulation

Fast PVR involves large generators operating in transmission networks and usually is synonymous with generator automatic voltage regulation (AVR). Only local measurements are used in PVR. The goal of PVR is to act over the reactive power injection in order to maintain a set-point voltage at generator terminals or in some cases when current compensation is used, further in the network at some real or artificial bus. The reference voltage values are set mostly by SVRs although direct setting by TVR also takes place when an SVR level control is not present. Stations supplying distribution networks through transformers with on-load tap changers possibly equipped with switchable shunt capacitors and reactors and/or more sophisticated faster equipment (synchronous condensers, SVCs, STATCOMs) are sometimes also classified as PVR.

Control area/block operators should have available a sufficient reserve of rapid reactive power resources participating in the primary voltage control in order not only to ensure normal operational conditions with a continuous evolving of load and transits but also to prevent voltage collapse after any contingency.

Secondary Voltage Regulation

SVR has to maintain a set-point voltage value within a certain band at some selected network node. The set-point value may come from TVR or directly from TSOs if TVR is not present in the system. The selected network node so called “pilot node” or “pilot bus” is representative of some part of the network from a voltage profile point of view. To achieve its regulation goal an SVR uses reactive power resources which are available in generators using rather slow and slight modifications of PVR set values. Typical time frames are in minutes for SVR. SVR supervises and coordinates the primary voltage regulators within an area, however solutions adopted for SVR differ among systems. In some systems SVR only controls the voltage of a power plant station bus using AVRs of individual generators. In other systems, more sophisticated solutions have been adopted where the pilot bus is not necessarily a power plant bus and SVR includes generators and other reactive power sources from a larger area (regulation zone). Examples of an SVR limited to a plant voltage control can be found in the Polish and some Balkan countries’ power systems. Often cited in papers, examples of more complex zonal SVR are from the French and Italian power systems.

An important function of SVR is the maximization of reactive reserves of the involved generators. It is realized by proper reactive loading of generators, controlling tap changers of step-up and coupling transformers and switchable shunt reactive power sources (if these measures are available). The main SVR control goal may be realized by an automatic PI controller or using some optimization algorithm with constraints (which is a better and more efficient solution). It is obvious that SVR, especially the zonal type, requires using a sort of SCADA system.

Tertiary Voltage Regulation

The tertiary voltage regulation represents an enhancement of the secondary voltage control scheme. It is usually based on a global system optimization which calculates updated voltage set-points for the regional voltage controllers associated with SVR. It is completed in a time scale ranging from 10 min to 30 min or even hours. TVR is generally present in all large systems but may have very different forms. The most primitive form of TVR involves set-point values for PVR or SVR given by operators based on their experience and/or on power flow analyses which are performed routinely by TSOs in various cycles (planning, day ahead, intraday). Increasing capabilities of SCADA-EMS equipped in power system state estimators provide possibility of

conducting real-time system security analysis and optimal voltage scheduling. Such solution of TVR is used in the Italian power system. In all cases the goals demanded from TVR are system operation security including voltage stability and minimization of losses. It seems possible that increasing performance of the SCADA-EMS systems might eliminate at some point in the future the need for SVR – optimal set-point values for voltage controlling equipment in transmission networks will be determined in real time based on appropriately frequent SCADA measurements. An obstacle for such solution may be growing dispersed variable generation which will definitely make system voltage control more complex.

Large participation of variable renewable generation in some systems (Germany, Denmark, Spain) already forced certain modifications to voltage regulation schemes which involve more active treatment of reactive reserve capabilities present in some types of dispersed generation. These capabilities (reactive power generation or consumption) may be activated based on system load conditions or remotely on request from system operators. There are also more installations of passive and active sources of reactive power in transmission networks (mainly synchronous condensers) which are necessary to safely handle bulk active power transfers resulting from large variable renewables and the growing electrical energy market.

4.1.3 Frequency and Voltage Control - the Vision of 2030

According to the European targets, the future energy consumption will be fed by a low carbon generation mix (involving high penetration of technologies such as wind and solar farms), while an important part of generation will be based on decentralized generators distributed all over the nodes of the power system. In the new power system structure, TSOs will be able to control significantly the lower part of the generation compared to the traditional centralized configuration, and thus they will no longer be able to compensate large deviations in the power balance. Theoretically, even a large power imbalance could be faced with accurate day-ahead predictions of decentralized generation and electricity demand of load centres, whether in practice this will be very difficult due to the intermittent distributed generation profile (depending on weather conditions). Moreover, increased electricity loads and sources such as EVs and residential PV systems, will influence the balance between day-ahead production and consumption schedule and will leave energy markets with higher and less predictable need for balancing power.

In order to face the above mentioned problems the traditional power system centralized configuration (top-down vertical control) will be changed into a bi-directional vertically and horizontally integrated control scheme, according to the next figure. Specifically, at a local (distribution grid) level, the distributed controls of the various actors are integrated in such a way to reduce the local power imbalance (solve local problems locally), while the different 'horizontal levels' support each other to maintain system wide power balance including an exchange of information about the global and local power balance and the related grid constraints on a "need-to-know" basis, together with required control signals such as a desired change in total load, generation or system synchronous inertia. The first statement depicts the horizontal integration, while the second one depicts the vertical integration. The aforementioned scheme originates from Electra main concept for the future structure of the electrical grids and it can be found in Electra IRP proposal.

The proper operation of the horizontal Integration control demands appropriate input signals that reflect the local horizontal power imbalance. These could be the SOC deviation from nominal in local energy storage, the price signals that are generated by virtual local energy markets, the power level deviations from circuit set-points, the voltage level deviations from nominal values, etc.

On the other hand the vertical Integration control operation relies on information and control signals that originate from local control schemes. The scope of the individual local control schemes is to reduce the power imbalance within a specific characteristic time-scale. This type of control may be referred to as “Horizontally-Integrated control schemes”, see Fig 5.

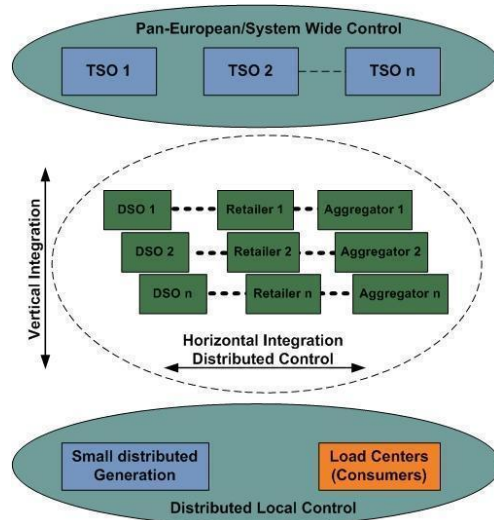

Figure 5: The bi-directional vertically and horizontally integrated power system control scheme.

The abovementioned power system configuration could be depicted as a combination of connected trees of system objectives and functions, decomposing the grid responsibility into cells (subgrids), see Fig 6. Each cell can still rely on imports/exports, but these are treated as ‘fixed’, and the cell is responsible for maintaining its local power balance at all timescales. Cells will be mapped on a hierarchical location and there may be more than one connection between neighbouring cells. Cells themselves will be configurable as well as the connections between cells and it will be possible to change them with respect to the allowable coupling limitations. The aforementioned concept as well as the figure 6 originate from the outcomes of Electra WP3 and WP4. More details can be found at Deliverable 3.1, [1].

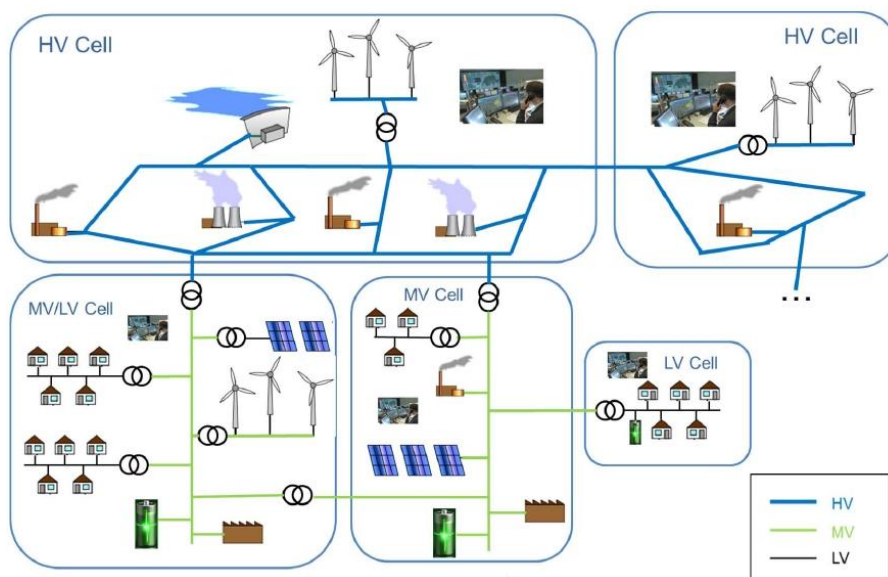

Figure 6: Future Power system configuration based on the combination cells (web of cells concept), [1].

In each cell, there will be only one system operator, which will perform reserve management in a similar way that TSOs perform for their Control Area or Control Block today. The system operator should perform Droop Control Actions both for frequency and voltage deviations and they will be responsible for restoring frequency and voltage to their nominal values (in an economically optimal manner). Besides, the cell system operator will be responsible for synchronous inertia control (in smaller scale due to the decreased cell power level). On the other hand it is possible that more than one Balance Responsible parties (BRPs) are to be involved in a cell.

4.2 Interactions between actors involved in Frequency Control

As it is already mentioned, the balance between generation and load must always be maintained to keep the power systems secure. Thus the power systems must be operated with preventative security margins. In other words, a sufficient backup capacity of generation and/or load (the so-called operating reserve) is needed in order to counteract any unforeseen event by substituting the quantity of demand and generation again.

Operating the power system with high amounts of reserves entails more security for the system, but at the same time increases the system operation costs. On the other hand, low amounts of reserves may cause ad-hoc operations which also increase the operation cost. Furthermore, energy generating units or load providing reserves should be dispatchable within few seconds or some minutes, thus increasing the necessity for flexibility of power system components. Therefore, an appropriate dimensioning and use of reserves are needed to maintain the system secure and also avoid unnecessary operation costs.

In order to achieve an economic power system operation, an efficient market design for electricity supply is required. During the last decade the market activities have increased and changed inside the European electricity networks. As a result the exchanges between market parties and control areas have not only increased but altered too. The following is a summary of the main reasons which lead to Interactions in frequency control due to the increased market activities inside European electrical grids and the inability of present power systems to solve the ensuing frequency stability problems. Similar interactions will be faced in cell operation too, if the following causes are ignored.

The energy market rules and active network management rules in sectors such as the balancing and the starting and stopping of generation are not well coordinated. The electricity market development and the continuously increasing number of market participants causes frequency disturbances at times when tariffs and schedules are being changed. Thus many frequency drops or peaks are detected at the hourly, half-hourly or quarter-hourly schedule changes between or with individual control blocks/areas. These frequency disturbances may be due to different control settings in control areas and/or different characteristics of the secondary controllers and corresponding reserves.

For example differences between European countries are observed: at controller type and accuracy, proportional term $-\beta$ - value, integral term value $-T$ -, and K factor (for measuring the ACE).

Inside a country, differences are detected: at reserves type (start-up time, max change in 30sec, ramp rates), the high power gradients due to fast connection or disconnection of some units (like hydro pump-storage), the mismatch between fast and slow generation, (short term unbalances).

The actors involved in Frequency Control and their respective roles may be the following [73]:

Balance Responsible Party (BRP):

- BRP interacts with the power production, consumption, markets and the cell operator.

- Concerning the energy production, BRP typically operates own production units.
- Concerning the energy consumption, BRP takes responsibility for the retailers' consumption and trades energy according to contractual agreements.
- BRP is balance responsible for minor third party owned production assets.
- BRP may sell electrical energy at neighboring cells,
- Balancing responsibility means that the BRP will be held responsible for imbalances in the energy market.
- If the BRP delivers ancillary services, it has a full delivery obligation.

Cell System Operator (CSO):

- CSO interacts with the BRP and with local controller and the central controller (if any)
- CSO buys access to manual regulating power by regulation reserve payments to BRP.
- CSO activates the manual regulating power by communicating with BRP.
- CSO is responsible for collecting and validating metered settlement data on transmission level for the BRP.
- CSO facilitates the financial settlement between ancillary service providers and BRPs to settle the activation costs of the ancillary services.

Cell Operational Information System (COIS):

- COIS sorts and presents the bids accepted by the CSO for the Regulating Power Market.
- COIS interacts only with the CSO.
- COIS receives the bids from the CSO.
- COIS shows the merit order list, which can be separated by price areas.
- The COIS is jointly operated by the local controller.

Distribution System Operator (DSO):

- DSO is responsible for collecting and validating metered settlement data on the distribution level for the BRP.

The above actors play roles both in technical and market operations. With respect to market operations, two important groups of actors are market players and market facilitators. In terms of the energy market, the market players are the BRPs and the market facilitator is the cell market. In case of the ancillary service markets, both the CSO and BRPs are market players. The COIS has a facilitating role, while the DSO does not have a market role as a player or facilitator- only a role with respect to settlement as metering responsible.

4.2.1 Interactions between actors involved in Voltage Control

To meet a high quality of supply and the voltage regulation objectives, a hierarchical control structure has been developed and organized in three control levels: primary, secondary and tertiary.

This hierarchical control system is widespread along the national HV grid, with the different components placed in different facilities: the power stations, the regional control centres and the national control centre.

A control scheme is shown in Figure 7, in which the main components are the following:

- AVR – it is the Automatic Voltage Regulator, the primary voltage controller, It controls the voltage directly at the generator terminals.
- PQR – it is the Reactive Power (Q) Regulator of a single power plant, and it is a component of the secondary voltage control
- RVR – it is the Regional Voltage Regulator, it has the goal to control the voltages of the pilot nodes of its electrical region
- NVR – The National Voltage Regulator is at the top level of the hierarchical control structure.

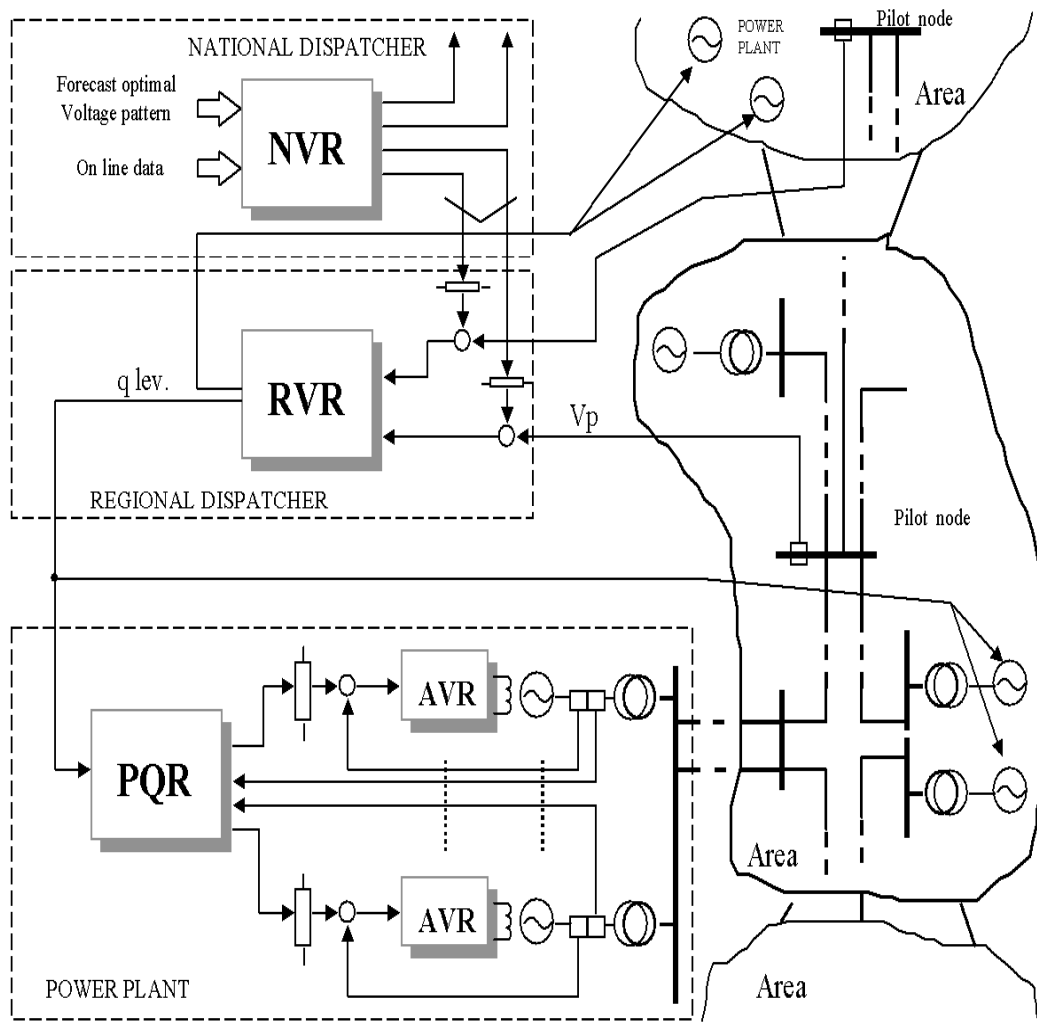

Figure 7: The scheme of the hierarchical voltages control of a National Transmission Grid.

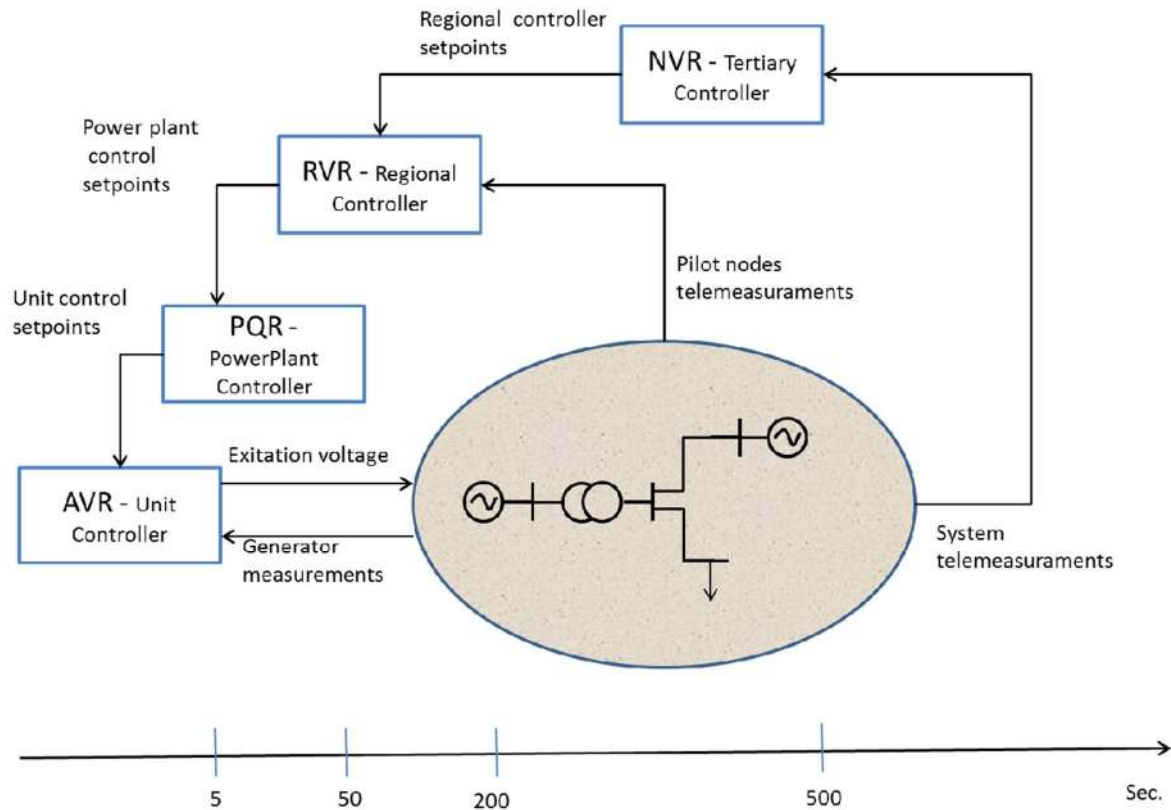

Figure 8: Time responses in closed loop of the hierarchical voltages control of a national transmission grid.

As shown in the figure 8 each controller sends to the lower level voltage or reactive power reference values. For stability reasons each control level is separated from the other, the figure shows the closed loop time responses of each one:

- 2-5 seconds for the AVR of each generator
- 20-50 seconds for PQR
- 100-200 seconds for the RVR placed in each Regional Control Centre
- 400-500 seconds for the NVR which has the goal to optimise the values of the Pilot Node voltages of the grid.

In the following, each voltage control level will be detailed.

4.2.2 Primary Voltage Control

The primary voltage control regulates the voltage of the single alternator and it is realized by the AVR, the Automatic Voltage Regulator, A typical feedback control scheme for a synchronous generator is shown in Figure 9.

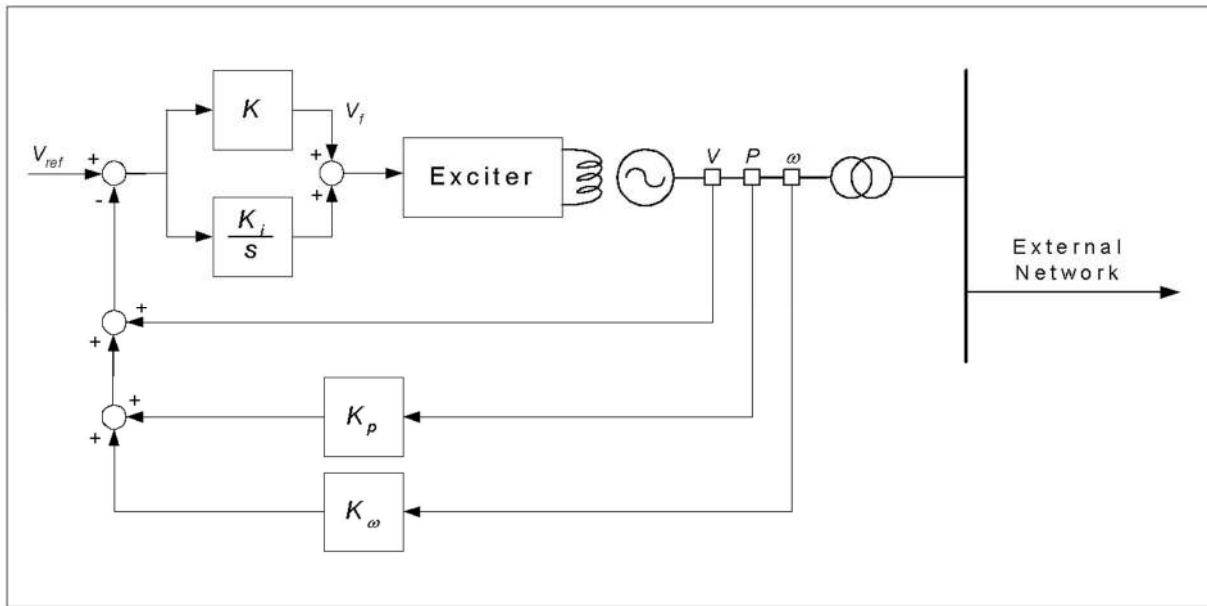

Figure 9: The AVR Controller.

The Figure 9 outlines the main voltage loop and the additional positive feedback (the PSS, Power System Stabilizers) from active power P and rotor speed ω . These signals are essential to guarantee the stability of the generator connected to the grid for different operation points, in presence of disturbances of different nature. The terminal voltage V of a the generator is controlled via the strength of the magnetic field of the alternator, which is determined by the excitation voltage V_f of the exciter, that is the input variable to control the alternator.

It is also necessary, independently of the type of power plant, to introduce the limits of the capability curve with the maximum and minimum value of the active and reactive power produced and absorbed. The voltage regulations of the generator verify if the generators are violating the reactive limits and if the option of the generated reactive power control is active.

4.2.3 Secondary voltage control

The secondary voltage control level of a transmission grid is constituted by two different regulators shown in the Figure 10:

- The PQR - the Reactive power regulator - is placed in those power plants which were chosen to regulate the voltage in some defined nodes (called PILOT NODES) of the transmission grid. The PQR receives the reference value of reactive power from the RVR, the Regional Voltage Regulator, and on the basis of this consignment the PQR controls the reactive power produced by each generator
- The RVR - Regional Voltage Regulator - has the goal to define the reference values of reactive powers necessary to satisfy the constraints of PILOT NODE voltage levels. These reference values are sent to the PQRs of the power plants which are under secondary voltage control.

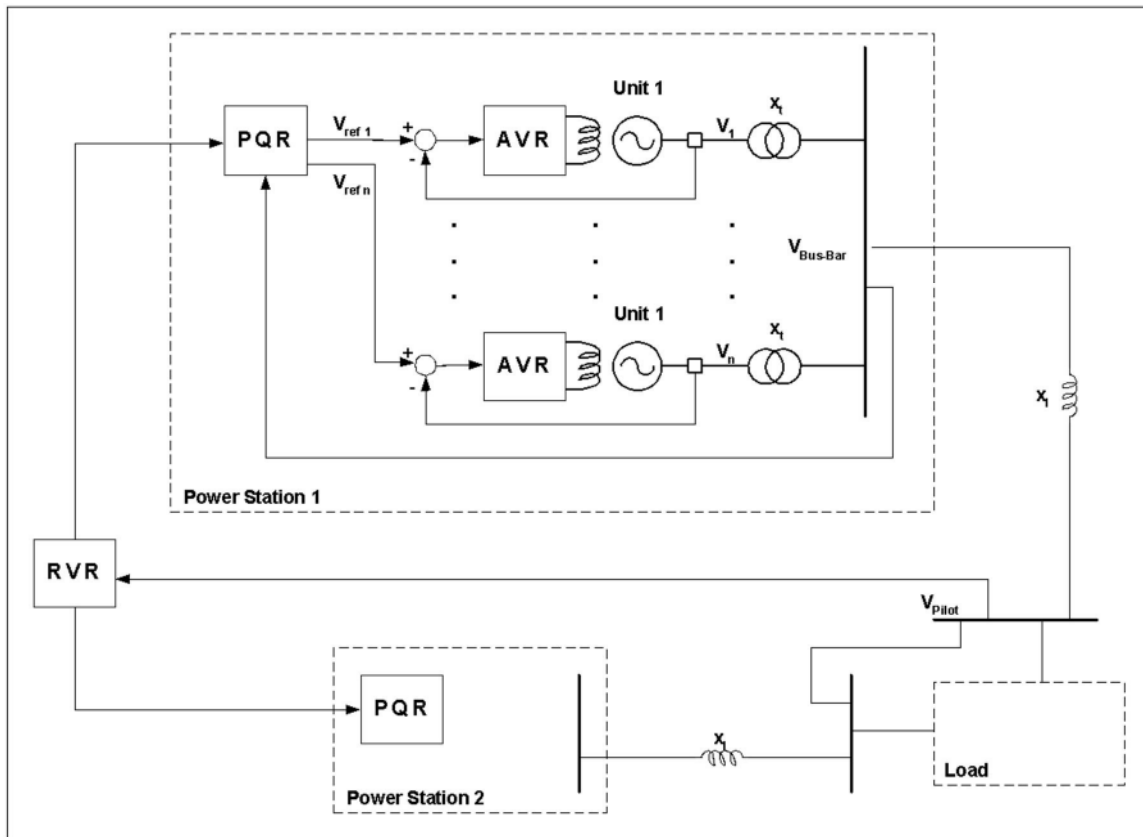

Figure 10: The Secondary Hierarchical Voltage Control Structure.

4.2.4 Tertiary voltage control

The highest level in the hierarchical voltage control is the Tertiary level that has the goal to optimise the values of the voltages in the pilot nodes of the entire national grid in order to minimise the losses of energy along the transmission grid.

In Figure 11 there is the general schematisation of the interaction of the centralised tertiary voltage control system NVR (National Voltage Regulator) with the other control level.

In order to define the optimal voltages profiles of the pilot nodes with the objective to minimise the losses on the transmission grid, the NVR uses different algorithms such as a state estimator, an optimisation algorithm, etc.

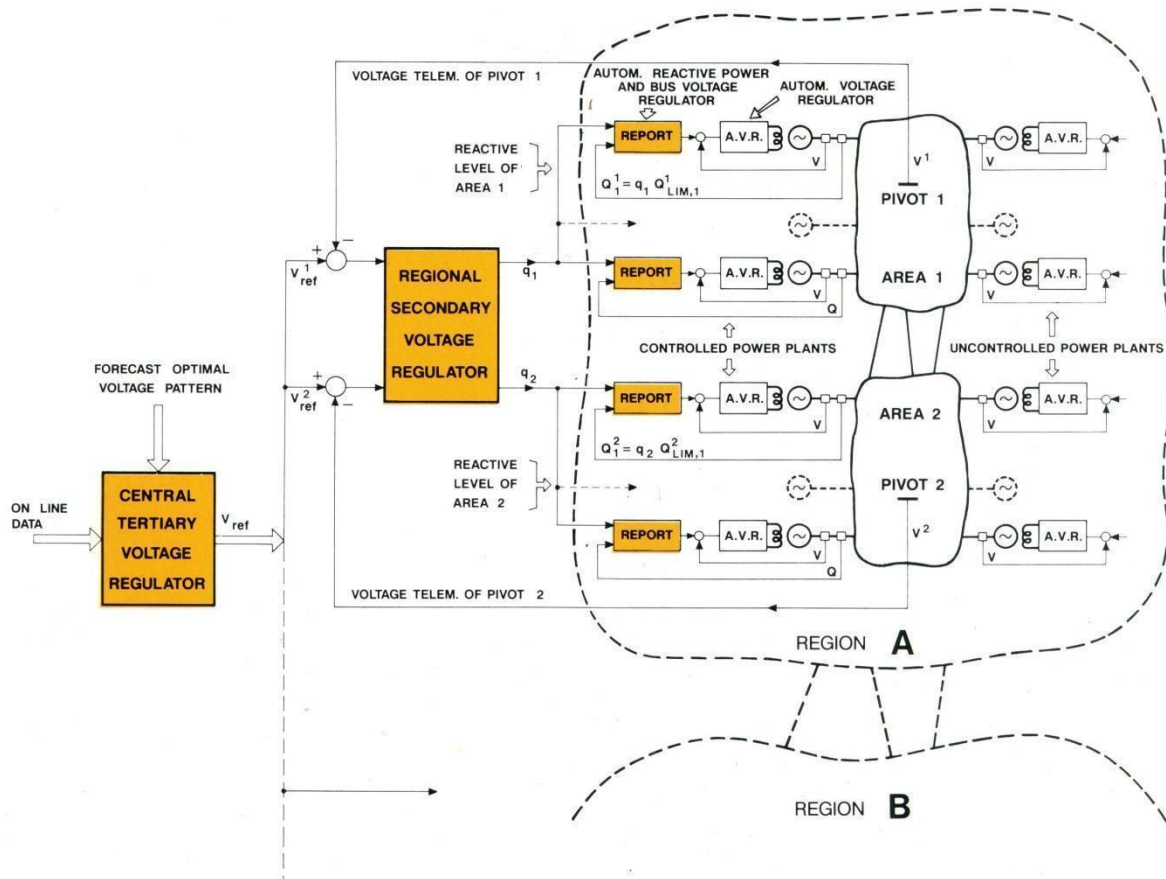

Figure 11: Voltage controllers interaction of the HV transmission grid.

4.3 Interactions modelling under normal and emergency situations

UCTE research activities have proven that an increase in quality and/or quantity of secondary control reserve does not improve the frequency quality during uncoordinated ramping, due to the relatively slow (centralised) activation of this reserve. The most effective way of reducing the critical frequency deviations during schedule ramping is to improve the quality of ramping by demanding this as far as possible from all acting parties in the same way: generators, loads and balance responsible parties. This will require corresponding adaptations of present grid codes, and future cells operating procedures, in order to create the required rules and necessary enforcement mechanisms.

Cell system operator and the BRPs should intercommunicate not only with the generation companies/units inside the cell but also with neighbouring cells, in order to implement rules for establishing a maximum gradient for total generation output and also for demand (as much as possible), at the hourly boundaries, considering ramping periods of +/- 5 minutes, to enable the remaining system unbalances (due to modifications of production, consumption and/or exchanges) to be controlled with the Load Frequency Control.

At cell level each system operator and the corresponding BRPs should coordinate with the generating companies feeding in their system the power plant schedule changes in such a way that they avoid as much as possible steep or step-wise changes in generation at hourly boundaries.

Cells System operators should have to monitor the application of these rules (above a specified relevant size) and implement specific incentives to form the consumption and the production inside their cells. At the same time the neighbouring System operators should exchange the above information between them, in order to not jeopardize subsequent reserve activation. Specifically, an additional load flow in some cell (due to the increased electricity needs of others cells) may harm their scheduled load flow, making them unable to activate a (local) reserve in case of a potential disturbance. Moreover, imbalance accounting should take into account the ramping rates and re-evaluate the mechanism of fixed prices periods in market environments.

Moreover the synchronous inertia control at the cell level should be re-examined due to the reduction of the rotating mass at the cell level. If this issue is not addressed, the Frequency Control Reserves may be activated more frequently and much faster.

4.4 Model based interfaces for demand response contributors

An increased growth of decentralized, mostly renewable, production may force a shift to a decentralized way of approaching frequency and voltage control as well. Local distribution grids will be used more dynamically resulting in more voltage issues. Considering the Sea-of cells concept, the generation units will be smaller and in many cases it will be renewable resources which make them less suitable for frequency control. For that reason a more important role for participation at the demand side will be expected for voltage and frequency control in the future.

Today, there are already a number of ways through which consumers can contribute (direct or indirect) to grid stability:

- Frequency reserves: consumers can contribute to reserve mechanisms of TSO's. This can be done directly (large industrial consumers) or via an aggregator which bundles the flexibility of a group smaller consumers. The main application would be tertiary frequency control, but there are known cases of primary frequency control that utilise consumer response.
- Electricity markets: by buying electricity on day-ahead and/or intraday market, companies are motivated to buy more when electricity is cheap (and readily available) and to buy less when electricity is expensive. Trading can be done directly (by large companies) or in an aggregated way.
- Strategic reserves: this type of reserves exists in Sweden, Finland and Belgium and is mainly used for solving extreme scarcity problems, which prevents the day-ahead market from clearing.
- Local balancing solutions: Renewable resources have to pay injection tariffs and grid usage fees can be a major part of the electricity cost. Local consumption of renewable energy (without injection to the grid) can reduce these costs significantly which results in an incentive for increased electricity consumption when a lot of renewable energy is available. This can reduce grid issues at other locations in the grid.
- Grid support: Although not widespread, there are known cases where local resources and loads are used in order to solve local congestion issues.

4.4.1 Interface requirements for demand response

Offering grid services is different for a demand response contributor compared to a large generator:

- Offering grid services is not the core business of the demand response contributor.

- 100% availability in most cases is not achievable.
- Activations times should be limited.

The bottom line is that the demand side can contribute to grid stability, but the contributor's constraints are more strict. Managing these constraints and making sure that the constraints are not violated will be a key element in enabling demand side flexibility to find its way to the market.

Further, it is important for a demand response contributor that interfaces can be used for different applications. Today, the interface for a company e.g. offering tertiary reserves is completely different to a company who trades in electricity markets. Identical interfaces would result in market transparency, market transparency will make it easier for companies to offer their flexibility to the market parties.

4.4.2 Model Based interfaces

In a "model based interface", the flexibility user and the flexibility contributor agree on a simplified model which describes the actual behaviour and constraints of the flexibility resource. The principle and the properties of a model based approach will be explained by means of the following example:

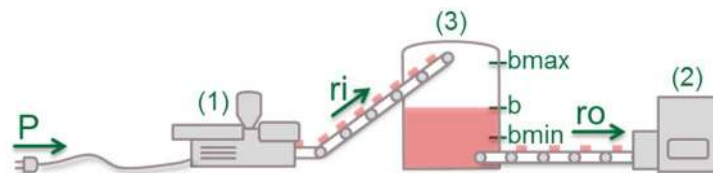

Figure 12: Explanation of the model based interface for demand response contributors.

The above Figure 12 represents an installation which is split up in 2 parts:

- The first part of the installation (1) contains a lot of flexibility and the output rate of this part is proportional with the electrical power which is consumed in (1)
- The second part of the installation (2) has no flexibility

Both parts of the installation are decoupled by means of a buffer where the intermediate product can be stored.

In the above figure the following notations are used:

- P [kW]: Electrical power consumption of the first part of the installation.
- r_i [ton/h]: production rate of the first part of the installation which feeds into the buffer.
- r_o [ton/h]: production rate of the second part of the installation which leaves the buffer.
- b [ton]: the actual filling of the buffer.
- b_{min} [ton], b_{max} [ton]: minimum and maximum filling of the buffer.
- P_{min} [kW], P_{max} [kW]: minimum and maximum power of the first part of the installation.

The flexibility, present in this installation can be described with a limited number of equations:

- $r_i = P \cdot K$ with K the production factor of the installation expressed in [ton/kWh]
- $db/dt = r_i - r_o$

and the following constraints:

- $b_{min} \leq b \leq b_{max}$
- $P_{min} \leq P \leq P_{max}$

The flexibility resource provides the flexibility user with state information (b), planning (ro) and the constraints (Pmin, Pmax, bmin, bmax). Based on this limited information, the user gets all information needed for the exploitation of the flexibility resource.

Once the interface is in place, there are 2 possible ways of working:

- The flexibility user takes control of P and takes care that the constraints are not violated
- In normal conditions, the flexibility contributor acts according to an agreed “normal behaviour”. Only when the flexibility user wants deviations from the predefined “norm behaviour”, the flexibility user takes over control.

The agreement on a model based interface between a flexibility user and contributor gives way to more possibilities compared to switching off a certain amount of power for a contractually agreed time:

- Capacity monitoring: based on the exchanged information, the flexibility user knows the available capacity at any moment in time and in its aggregated portfolio. It can monitor the availability over time and use that information to calculate the remuneration.
- Real time capacity planning: The model based interface allows to go a step further than capacity monitoring. Due to a basic understanding of the underlying process, it is possible to calculate the future available capacity based on the current state and planned actions.
- Rebound control: the activation of flexibility sometimes results in rebound effects. This means that after the demand response event, the flexibility resources try to recover from the event. This might result in a temporary higher or lower power consumption which is called the “rebound effect”. In a model based interface approach, the flexibility user knows the state of the flexibility resource and can estimate how urgent the recovery is. In many cases the recovery can be postponed to a moment in time which is safe for the grid.
- Incident anticipation: not all incidents can be predicted (e.g. failure of a power station) but some incidents don't occur completely unexpectedly. Examples:
 - o Peak consumption close to the grid limits on a cold winter day with limited renewable resources available.
 - o Peak production of renewable resources on a bank holiday with limited economic activity

For this kind of incidents, the flexibility user can decide to anticipate its portfolio in order to create extra flexibility in case an event takes place. This approach makes it possible to prepare the same flexibility resource for different types of events (reduce or increase electricity consumption).

- Multiple actor interface: a model based interface only describes the physical capabilities and constraints of a flexibility resource but doesn't define how the flexibility should be used. That makes the interface suitable for multiple actors in the market.
- Bidirectional communication: parameters and constraints do not have to be constant over time. The flexibility resource can communicate new constraint values or parameters in real time when an incident occurs.

4.4.3 Hardware abstraction

In the previous section the concept and possibilities of a model based interface are explained. The shown example, however, is difficult to use in practice because all parameters are very specific to the application. The fact that the flexibility resource is a buffered process which has parameters

and states as “buffer level” and “production rates” expressed in ton and ton/h on the interface is irrelevant information for the flexibility user.

The original equations and constraints can be converted easily into equations and constraints which only contain power and energy. This is shown in the figure below. On the left hand side, all equations are divided by the application specific production factor in order to achieve a set of equations and constraints which describe relationships between power and energy, see Fig 13.

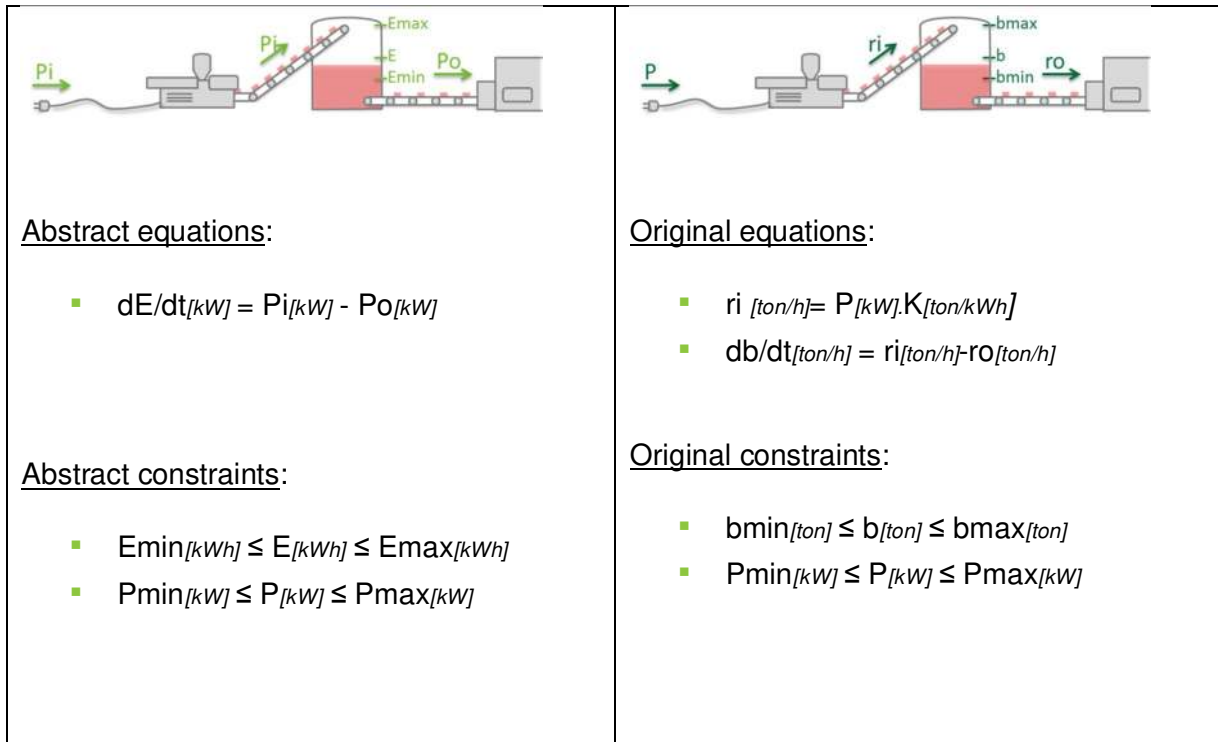

Figure 13: Adaption of the original equations and constraints in power and energy terms.

This conversion is called a hardware abstraction which has two major advantages:

- Lots of processes can be mapped to universal energy and power equations which results in an identical interface from the flexibility user point of view.
- The specific knowledge of the industrial process is present on the flexibility resource side of the interface. On that side, the translation to power and energy parameters can be performed more readily.

4.4.4 Flexibility categories

In the previous sections, the concept of model based interfaces and hardware abstraction was introduced. It is not obvious, however, to map all kinds of flexibility resources on one single generic abstract interface. The actual number of flexibility interfaces needed in order to describe all sources of (demand side) flexibility is still under investigation. In this categorization, a good trade-off between generality and specificity is important: the more generic interfaces are, the more applications can use the interface but they can become cumbersome. As a first indication, it is expected that most demand response contributors can be fitted into 2 to 4 different interfaces.

5 Modelling the conflicts across multiple control boundaries

This section describes the main outcomes of the work conducted under subtask T6.1.3 including the definition of controller conflict from a flexible power system perspective, a review of state of the art in power system control conflict and an outline of the methodology for identifying these conflicts during system operation and their impact on system stability. There are important dependencies between this subtask and subtasks T6.1.1 and T6.1.2 in addition to interactions with other research work packages – mainly subtask T4.2.2 (interworking with WP5 and WP6 for monitoring and control functions specification).

Starting with a fundamental assumption that a power system constitutes a high level of controllable flexibility resources, the following main objectives of T6.1.3 are presented:

- The determination of direct sources of control conflicts and their extent across control boundaries in light of system interactions defined by T6.1.2 and detailed frequency and voltage control use cases developed in WP4.
- Quantification of the impact of aforementioned control conflicts on frequency and voltage stability and consequently guiding functional specifications of novel controllers to mitigate or manage these conflicts under normal and emergency situations.

5.1 Definition and causes of controller conflict

5.1.1 Definition of controller conflict

In order to establish a clear relationship between conflicting behaviour of controllers and the impact of such behaviour on the system frequency and voltage, it is necessary to define a working definition of controller conflict. Thus, the identification and analysis of the phenomenon can be focused on those interactions that are directly relevant to controller interactions. Although factors indirectly influencing controls into conflicting behaviour (e.g. electricity market rigging), the rationale behind focussing on controller interactions stems from the ability to directly derive clear functional specifications for novel controllers to be developed. To this end, traceability and testing of requirements can be achieved readily. Provisions for non-direct factors driving controller conflict can be made separately in the high level use cases and design specifications.

A simple working definition is proposed in order to define controller conflict and is presented as follows:

A **control conflict** is an undesired change of an intended **control action** as variable in a system of physical devices as a response to a change in the set point of a controller.

The cause of these undesired changes will be made clearer in the following subsection.

The occurrence of controller conflict implies that oversights in controller development occur especially in the specification and design stages. Thus, conventional approaches to controller development as adopted by power systems specialists may not be entirely suitable. And new controller development and testing philosophies may need to be applied, which must take into account the influence of other controllers and global grid parameters. This is not to imply that coordinated control schemes are the only suggested solution to controller conflict, but it is to emphasise the importance of a holistic approach to specification, design and testing of controllers for a highly flexible power system.

5.1.2 State of the art and identification of the causes of controller conflict

Presenting the state of the art and experiences in controller conflict in network operation scenarios provides for a solid starting point where the problem and its impact on system stability can be better understood. To this end, this section summarizes the main findings from the literature and from participants' experience in terms of scenarios or examples of controller interactions resulting in conflict. A measure of controller conflict is presented for each example. This can be used as an indicator of the impact of controller conflict on system stability. Suggestions for resolving controller conflict are also presented, which will inform the development of flexibility control requirements. These examples are presented in Table 14 below.

Table 14: Summary of examples and experiences of controller conflict involving flexibility resources.

Nature of control scheme	Interacting controllers or parties	Nature of conflict	Measure of conflict	Possible approaches to conflict resolution
Distribution system energy balancing [73]	Energy balancing controls contributed by distribution network and services provided by prosumers	DSO requires the reduction of power exchange due to local constraints while a VPP/aggregator requires that more power is produced due to favourable market price	Violation of local network constraints	Multi-agent based coalitions representing network and prosumer interests could be used
Distribution system voltage control [74]	Transformer automatic tap changer control and DG active and reactive power control	Conflicting voltage control objectives of minimizing system voltage deviations, while reducing tap changer operations and maximizing transformer and DG utilization	Tap changer hunting or suboptimal asset utilization	Multi-agent based cooperative control scheme to reach a best compromise between global and self-objectives at any given time
Distribution system voltage control [75]	PV reactive power control and voltage regulator (VR) automatic tap changer control.	VR tap changer runaway condition (maximum/minimum tap position without reaching target voltage) may ensue mostly during reverse power flows due to PV	Violation of voltage limits	Performing optimal reactive power dispatch to limit tap changer operating range considering in light of system constraints

		generation		
Local DER voltage controllers [76]	Multiple DG voltage controllers	With large quantities and close proximity of inverter interfaced DG, DG controller and network interactions can give rise to controller oscillations and small signal stability issues	Frequency instabilities	Identification of oscillatory contributions of DG and impact of controller location within the system to take into account during design and deployment of DG and associated controllers.
Energy balancing [77]	Price responsive energy balancing generation and load controls	Balancing markets with relatively long clearing times and short price signal communications delays may destabilize the system where price sensitive controls respond out of synch with the market	Frequency instabilities	<ul style="list-style-type: none"> • Reduction of the proportion of price sensitive controls • Careful choice of intervals for price communication
Active network management using flexibility resources [78]	Controller for flexible demand, generation and energy storage	Conventional optimal power flow (OPF) used to dispatch these resources consider constraints for a single point in time, as such the effect of resource constraints such as energy storage capacity/state of charge may be ignored over time. Thus controller actions may not take into account these resource limitations	Insufficient flexibility response over time	Inter-temporal variables (e.g. energy storage stage of charge) should be formulated as part of a 'dynamic' OPF solution

DG control in thermally constrained networks [79]	Load flow-dependent curtailment of a maximum of 5% of the yearly energy feed-in to the grid on a per-generator basis in maximum load situations	5%-curtailment action might collide with local controllers or contributions to active power commitments in Virtual Power Plants	Violation of thermal constraints at network interfaces	Multi-agent-based cooperative control or model predictive control can be used
Higher level voltage control at TSO/DSO interface [source: iQ-Control project]	Higher-level (iQ) controller for reactive power balancing at the HV/MV interface is set to meet contracted reactive power set points between TSO and DSO	iQ-control action might conflict with local voltage controllers	Conflicting set-points from different controllers and voltage band violations	Multi-agent-based cooperative control or multi-criteria optimization can be used
Frequency control support from DG [80]	DG inverter f/P-control	With large quantities and close proximity of inverter interfaced DG, DG controller and network interactions can give rise to controller oscillations and small signal stability issues	PLL oscillation of DG inverters and power oscillations	Multi-agent-based cooperative control scheme to find a stable multi-inverter configuration or adaptive local control
VPP and ancillary services control [81]	Active power control (VPP-scheduler) and inverter controller of DER	Activation of ancillary service provision by inverter controller (e.g. voltage control or activation of primary/secondary control power) may influence active power provision of DER and thus yield deviation from VPP-schedule	Deviation of active power flow from schedule	Separate DER used for VPP and ancillary services to ensure that system stability is prioritized
Local voltage control of	PV inverter controllers	PV inverters may operate using a	Power quality of network where	Use of appropriate

<p>inverter-based generation [10]</p>		<p>reactive power droop control based on local measurements, which may result in oscillations in reactive power contribution between adjacent PV inverters</p>	<p>PV is installed</p>	<p>damping ratios</p>
<p>Grid congestion management [82]</p>	<p>Multiple controllers of active nodes and participants connected to the grid and contributing to a flexibility market</p>	<p>Possible conflict between a wide range of controllers and participants (e.g. VPP, LV controller, flexibility operator).</p>	<p>Level of grid congestion</p>	<p>Introduction of a 'traffic' light concept to govern market functionality based on grid state (e.g. normal, sub-optimal, exceeding limits)</p>
<p>Grid services provided by DER [83]</p>	<p>Controllers associated with a large scale deployment of DER</p>	<p>Multiple grid services that utilize DER could potentially be conflicting in operation given the large scale of DER deployment</p>	<p>Varies with nature of stability issues introduced to the system</p>	<p>Grid services can be prioritized based on based on considerations regarding the nature of the service and the state of the grid</p>
<p>Flexible demand for congestion management [84]</p>	<p>Indirect control of domestic LV heating load</p>	<p>Increased electrification of loads (heating, EV) may lead to overload of distribution transformer, and consequently the necessity to shed heating loads to alleviate congestion which reduces customers' quality of service (i.e. decrease in household</p>	<p>Transformer congestion vs. household heating (or comfort) levels</p>	<p>Usage of household thermal inertia as an energy buffer</p>

		temperature)		
Grid voltage control [source: studies and practical experience with Polish grid]	Automatic tap changer control and generator AVR	Tap changer and AVR each regulate local voltage according to set points. This may result in an overall rise in grid voltage	High reactive power output from generators while tap changer is at or close to its tap limit	<ul style="list-style-type: none"> • Application of a droop characteristic to voltage control • Coordinated set points between AVRs and tap changers.
Grid voltage control [source: studies and practical experience with Polish grid]	Generators' voltage controllers	Generators in close proximity and all operating in voltage control mode result in some generators consuming reactive power produced by other generators	Generators operating at very different power factors	Application of a droop characteristic to voltage control
Power oscillation damping [85]	Power system stabilizers (PSS), FACTS device stabilizers (FDS) and responsive generator governors	Interactions of an electromechanical nature involving aforementioned stabilizers generally tend to degrade system damping particularly for inter-area oscillation modes, but may also enhance damping of some local-area oscillation modes. Further interactions may ensue involving responsive generator governors which lead to system oscillations	Increasing the gain of a stabilizer may improve damping of one inter-area oscillation mode while degrade the damping of a second mode	Proper setting of PSS, FDS and governor parameters based on comprehensive system analysis
Active power control through HVDC links [86]	HVDC (LCC type) current/power controllers in multi-infeed system	A request to increase the active power infeed from one HVDC link result in the consumption of reactive power	Multi-infeed interaction factor, modal maximum available power and modal voltage	Operation of one of the HVDC links in current mode instead of power mode

		<p>which depresses the AC side voltage. The DC voltage in other HVDC links becomes depressed as a result of this and consequently their active power injection is also reduced. To counter act this, these links attempt to increase current drawn to maintain previous active power level which results in further voltage depression in an unstable manner</p>	<p>sensitivity factor are typically used to characterize this problem</p>	
<p>Network congestion management [87]</p>	<p>Maximum power point tracking (MPPT) of wind turbines and dispatching center's EMS</p>	<p>MPPT operation maximizes the power output from wind turbines, but EMS may curtail wind generation if the network is congested</p>	<p>Curtailment of wind generation</p>	<ul style="list-style-type: none"> ● Utilization of energy storage ● Use of active network management or wide area control

Grid operating conditions can have a great impact on the development of controller conflicts. Normal, stressed and emergency grid operating states can stimulate the occurrence of controller conflict in different ways. Protection systems in particular can be prone to performance degradation during stressed and emergency system conditions. This is because protection systems are geared towards dependable operation rather than secure operation, thus resulting in mal-operation when the grid is experiencing instabilities [88]. Consequently, the grid becomes more vulnerable to further instabilities. It is foreseen that operating the grid in more flexible manner including the maximisation of flexibility resources and asset utilisation may exacerbate such protection performance problems. A few examples to illustrate this problem are summarised in Table 15.

Table 15: Impact of grid state on the performance of protection schemes.

Protection schemes affected	Nature of conflict	Possible approaches to conflict resolution
DG and grid frequency based	Disconnection of generation	Tuning of non-detection zone

<p>protection including under-frequency, rate of change of frequency and low frequency demand disconnection [89]</p>	<p>leading to system frequency excursion can result in DG frequency protection tripping due to very sensitive settings which leads to further destabilisation of system frequency. Low frequency demand disconnection (LFDD) protection can be used to avoid further system frequency dips. However, if frequency responsive demand of further net power exporting DG is disconnected by LFDD, then the system will be destabilised further.</p>	<p>of DG loss of mains protection. Adaptive protection settings tuned for prevailing grid conditions</p>
<p>DG voltage and frequency protection [90]</p>	<p>Inappropriate fault ride through (FRT) capabilities can result in their unnecessary disconnection during system disturbances. For instance, the disconnection of DG due system frequency instabilities may result in increased power export to the distribution system. Subsequently, a voltage rise may occur which can lead to further DG disconnection.</p>	<p>Improved FRT requirements</p>

It is clear from the examples presented above that the presence of multiple flexibility resources and the lack of coordination between associated controllers can be a major driver for conflicting control behaviour. Some of the most prevalent factors giving rise to controller conflict include:

- Contention between two or more controllers over a shared controllable resource;
- Divergence between local and global (system) control objectives or constraints;
- Time domain discrepancies between control actions and physical system or device parameters to be controlled.

Furthermore, the grid operating state can have a direct impact on the manifestation of controller conflict. This is especially the case when the grid is in a stressed state and controller conflict results in a further deterioration of the grid's stability.

5.2 General methodology for controller conflict identification in a system with high penetration of flexibility resources

Interactions between controllers described using a static framework such as the SGAM¹ are not sufficient to tease out the extent of the controller conflict and its impact on grid operation. To this end, a dynamic model of these interactions is necessary. This section describes the methodology proposed to construct such a dynamic model for the purposes of extracting conflicting interactions of interest from the point of view frequency and voltage stability. The methodology is depicted in Figure 14, which also represents a logical sequence of dependencies of subtasks within T6.1. The different stages of this methodology are detailed below.

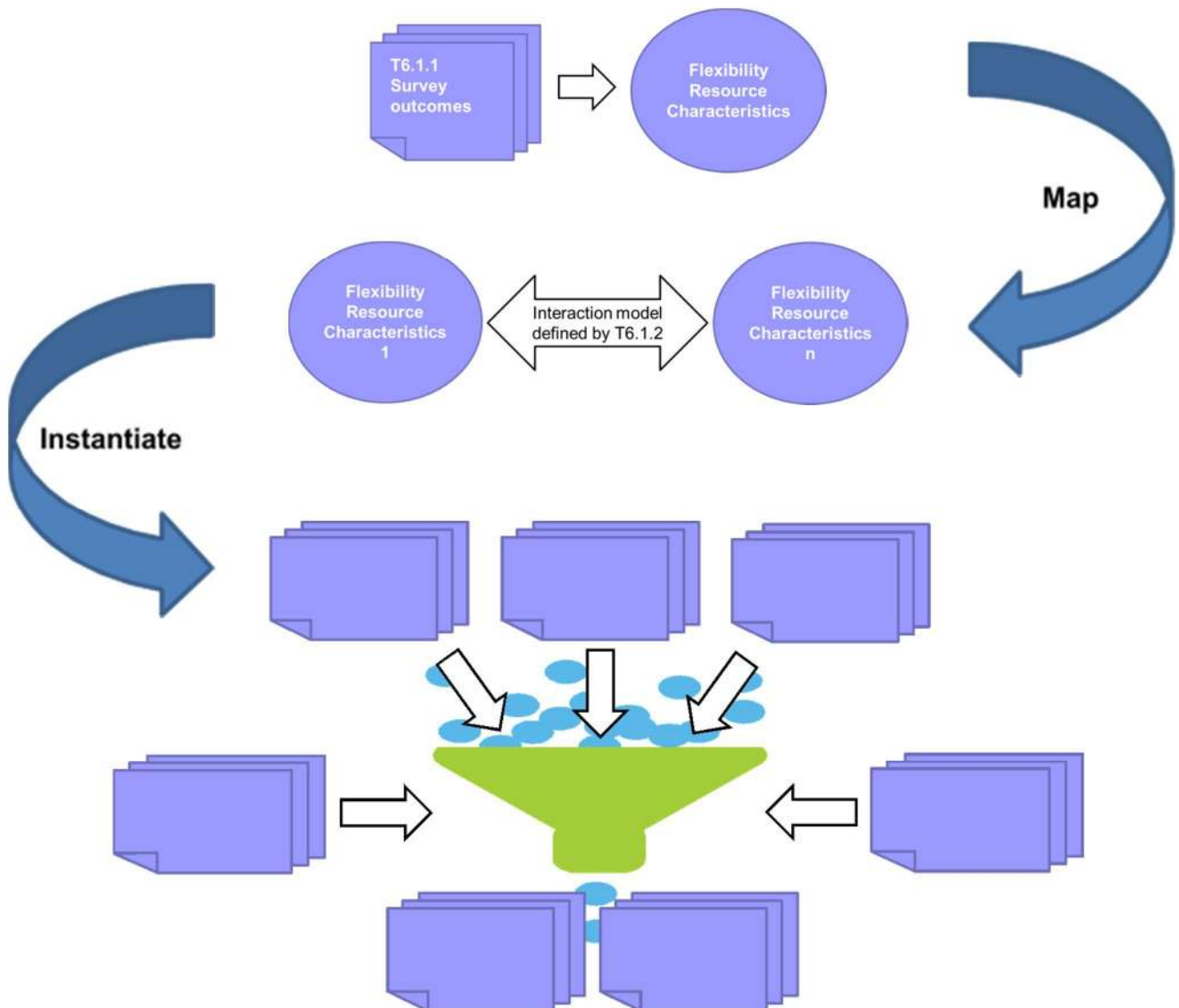

Figure 14: General methodology for the identification of controller conflicts.

¹ However, using the SGAM one can describe on which levels controllers may interact. Using the SGAM toolbox, also dynamic processes can be modeled. [mb11]

5.2.1 Mapping between flexibility resources

The capabilities of the flexibility resources form the core of the dynamic interactions which may lead to controller conflict. These capabilities include resource capacity, time response and limitations during operating conditions. As such, the information collected from T6.1.1 about the different flexibility resources will be used to characterise their behaviour during normal and emergency conditions.

In a conflict situation, a flexibility resource may exhibit a behaviour that is directly influenced by another controller or indirectly by the influence of a controller action on the network where the flexibility resource is connected. Distinguishing between these two different sources of behaviour stimulations is important in the development of the mapping between different flexibility resources in the form of controller interactions. In other words, the nature of interaction between flexibility resources and associated controllers will determine suitable pairings between these resources in the context of conflict identification.

At this stage, the linkage between T6.1.2 and T6.1.3 becomes more prominent as boundaries of control (or control domains), and consequently interactions can be more formally defined as discussed in section 4 of this report. Depending on the controls within each boundary, pairs (or generally tuples) of interacting controllers can be identified and further analysed for the presence of conflicts.

5.2.2 Development of representative control sequences

Key to this stage, is the development of detailed use cases for frequency and voltage control that define the dynamics of interactions between the different controllers. For every pairing identified in the previous stage, a dynamic scenario is created (or instantiated) where the reaction of each controller is examined in response to stimulations by other controllers or system events as defined by the use case scenarios. These stimulations and corresponding reactions are termed as control sequences. Multiple control sequences can be defined to aid the discovery of controller conflicts through a comprehensive means of simulation.

5.2.3 Identification and classification of controller conflict

Although some controller interactions identified in the previous stage may be classed as conflicting, it may be the case that that impact of these interactions on system stability is non-existent or negligible. Thus it is important to take into account the system state (and associated operating constraints) when assessing the need to address identified conflicts. So, conflicting behaviour may be classed as acceptable or unacceptable (undesirable) for a given operating scenario. And this classification may well change over time with changing operating conditions (e.g. level of flexibility deployment, network constraints, normal or emergency operational state, etc.).

One clear way to classify controller conflicts is to divide them into conflicts affecting frequency stability and conflicts affecting voltage stability. These two phenomena are usually analysed separately, since it is different elements of the power system that take part in voltage and frequency control, however in complex scenarios these two can be interlinked. This would be the case particularly in the islanded systems where in case of a large power imbalance (due to e.g. generator tripping) both voltage and frequency would start to decay, but since voltage drop affects voltage-sensitive loads, the frequency drop would proceed with a slower pace delaying underfrequency load shedding, thus not allowing for a basic countermeasure to power imbalance.

Conflicts can also be distinguished based on the location and spread of the conflicting agents:

- point-to-point conflict is a conflict between two agents, e.g. a single generator and TSO, often resulting from external constraints, market operation or wrong control parameters;
- point-to-group conflict affects a group of elements and a single party like DSO, TSO or Aggregator;
- group-to-group conflict is a conflict between multiple representatives of two or more groups of agents.

Based on the above classification conflict severity can be assessed and a solution can be easier to find.

5.3 Impact of controller conflict on frequency stability

Referring to the IEEE/CIGRE classification [90] frequency stability is one key aspect of overall power system stability, beside rotor angle stability and voltage stability. Frequency stability refers to the ability of a power system to maintain steady frequency following a severe system upset resulting in a significant imbalance between generation and load. Frequency stability can be divided into short term and long term stability. Depending on the process (-es), which is causing the frequency excursion, time range can vary from fraction of seconds to several minutes until the system reaches an unstable state. Instability that may result occurs in the form of sustained frequency swings leading to tripping of generating units and/or loads. Severe upsets generally result in large excursions of frequency, power flow, voltage, and other system variables, thereby invoking the actions of processes, controls and protections. In large interconnected systems large frequency excursions may be also responsible for splitting the grid into islands. Stability in this case is a question of whether or not each island will reach a state of operating equilibrium with minimal unintentional loss of load. Generally, frequency stability problems are associated with inadequacies in equipment responses, poor coordination of control and protection equipment, or insufficient generation reserve.

From the system point of view it is most important to maintain the system in a stable state in terms of frequency stability keeping up the power generation and consumption equilibrium. An example for short term frequency instability is the formation of an undergenerated island with insufficient underfrequency load shedding such that frequency decays rapidly causing blackout of the island within a few seconds [92]. On the other hand, more complex situations in which frequency stability is caused by steam turbine overspeed controls [93] or boiler/reactor protection and controls are longer term phenomena with the time frame of interest ranging from tens of seconds to several minutes [94], [95], [96].

During frequency excursions, voltage magnitudes may change significantly, especially for islanding conditions with underfrequency load shedding that unloads the system. Voltage magnitude changes, which may be higher in percentage than frequency changes, affect the load-generation imbalance [90]. Considering this fact, load shedding may make the situation worse because of following increased voltage through system unloading.

5.3.1 Identification of conflict scenarios impacting frequency stability

Requirements for modelling frequency instability

In order to properly analyse and model frequency dynamics, it is crucial to have clearly in mind the main equation that rules this kind of dynamic, the equation of motion:

$$\Sigma T_m - \Sigma T_e = J_{system} \cdot \frac{d\omega_e}{dt} \quad (2)$$

where J is the combined synchronous inertia of generators and turbines in the power systems, ΣT_m and ΣT_e the sum of accelerating and braking torques of the generators and loads in the system and ω_e the system electrical speed (or frequency).

The accelerating torques are determined by the prime movers that drive the generators; depending on the type of prime movers installed in the power plants, dynamic response may vary significantly: it may range from an extremely fast response such as the one in hydro plant, to a very slow one such as the one in nuclear power plant. In case of thermal units, the thermal properties of the boiler or of the turbines may heavily affect the ramping capability of power plant as in the case of once-through boiler steam power plant or gas fired power plants. The braking torques depends instead on the amount of power that is consumed in the system. Both values may be fairly known: the braking torque depends on the system consumption, which can be estimated quite accurately hour by hour, the accelerating torques depend instead on the power plant dispatch of conventional power sources while it may get quite unknown for renewables production.

It is important to be aware of the fact that until few years ago, in a power system dominated by conventional resources, ΣT_m was 100% controllable by power plant owners and indirectly by TSOs. Nowadays the share of controllable T_m is progressively missing due to the fact that more often power systems are running with a high share of renewable, such as wind and PV, uncontrollable sources. It is well known the Danish case where already for several hours a year, local wind production matches the consumption. It has to be mentioned however that the system is still in a reasonable controlled state thanks to the presence of strong interconnections to both the Nordic and the Continental systems. Having this in mind, it may be necessary, in a near future, to be able to replace the source of frequency controllability, which was once heavily provided by the accelerating part of that equation (T_m), by the braking part of the equation (T_e) that means the consumption. Demand can in principle provide upward and downward frequency regulation even though this may go in contrast with users' needs. On top of that it has to be mentioned that having few, big, certain power plants capable of controlling the system frequency is much more straightforward and secure rather than having to rely on thousands/millions of small units, whose behavior, even if potentially driven by market movers, may be unpredictable and unreliable.

Another critical parameter which may not be known a priori is the system rotating inertia. Instead of using the physical synchronous inertia J (expressed in $kg \cdot m^2$), it is convenient to refer to the per unit equivalent, often called $2H$ (expressed in seconds) or decay time. $2H$ is defined by the ratio between the kinetic energy (in Ws) and the base power (in VA):

$$H = 0,5 \cdot J \cdot \omega^2 / P \quad (3)$$

Using the per unit system is much more convenient because it allows to compare easily inertia of different sizes machines. This is due to the fact that for optimal machines designing reason, the amount of iron and copper in the rotor is always proportional to the amount of power the machine can handle. Generally, in conventional power plants $2H$ ranges often between 6 and 10 seconds and therefore power system synchronous inertia is simply the weighted average of all the power plants connected in the system. Increasing presence of synchronous inertia-less sources (such as PV or full converter wind turbines) or extremely low inertia wind turbines (DFIG wind turbines have

actually a fair amount of synchronous inertia, the MPPT control however can track so quickly the power output of the machine that in practice any potential inertia contribution of the machine is close to zero) lead therefore to a sensible reduction of rotating masses in the system, threatening therefore system stability. It has to be mentioned in this case that the demand cannot help in the inertia response as great part of the load is static and even the rotating one (i.e. asynchronous machines) have smaller synchronous inertia compared to the one provided by power plants, see Table 16.

In summary, as in all power systems studies, accurate modelling of power systems components, both generators and loads, is essential. With respect to frequency stability studies, what becomes critical is the evaluation of:

1. amount of synchronous rotating masses in the system,
2. droop values of generators and dynamic response of governors,
3. frequency relays threshold for under/over-frequency protection both for generators but also for substations.

Table 16: Model components and their importance.

Model component	Component's importance from voltage stability viewpoint
DG inverter f/P-control	With large quantities and close proximity of inverter interfaced DG, DG controller and network interactions can give rise to controller oscillations and small signal stability issues. This could lead into PLL-oscillation of DG-inverters which cause power-oscillations. [96]
Active power control in VPP vs. ancillary service provision	Activation of ancillary service provision by inverter controller (e.g. voltage control or activation of primary/secondary control power) may influence active power provision of DER and thus cause deviation from VPP-schedule. [97]
Active power controllers of large coal-fired power plants and wind farms	In order to make room for the production of a wind farm, traditional power plants (such as coal/lignite-fired) need to be limited. Wind generation is inherently variable. Increase of wind generation is usually balanced by shutting down hydro plants and reducing coal-fired power plants. Possibility of reducing generation of steam turbine is limited by permissible technical minimum. On the other hand, some generators have to stay connected to the grid to cover demand in case of rapid decrease of wind generation.
SPSC (special protection and supplementary control for deloading and antiswing) and AGC (automatic	When one of the lines connecting a power plant to the power system is tripped due to e.g. a fault, the SPSC will recalculate the maximum allowable power for this power plant that assures transient stability in case of another fault. The new allowable power value might mean decreasing power order or even

generation control)	tripping of one the generators in operation and a result power level ordered by AGC might not be achieved. [98]
MPPT (maximum power point tracking) in wind turbines and the controller for external frequency support	Frequency support in DFIG (double fed induction machine) wind turbines is obtained by temporary shifting the operating point away from MPPT to drain or store more energy from/into the rotating mass of the turbine's rotor. This means that MPPT cannot achieve its goal due to frequency support controller operation. [98]
Overfrequency relay from wind turbines	In case of large overfrequency events, it happens that overfrequency relay disconnects wind turbines once the frequency crosses 50.3 Hz. Turbines started getting reconnected (providing accelerating power to the system) with the frequency still well above 50 Hz (but close to 50.3 Hz), as for example happened during the European system disturbance of 4 Nov 2006. [99]
Hydro Power Plants - Speed control under islanding conditions or other isolated modes of operation is in conflict with the governor settings required for fast loading and unloading under normal synchronous operation	For rapid load changes, it is desirable to have a fast governor response. However, the governor settings that result in a fast response usually cause frequency instability under system-islanding conditions. Unless properly managed in the frequency control system with proper transient compensation tuning. [100]
5%-controller might collide with local controllers or contributions to active power commitments in virtual power plants (VPP)	Load flow-dependent curtailment of a maximum of 5% of the yearly energy feed-in to the grid on a per-generator basis in maximum load situations. Conflicting set-points from different controllers, overloading of operation equipment. [101]

Possible control conflicts affecting frequency stability

There is a great variety of processes which can lead into frequency instability situations. Frequency instability can be divided into short term and long term stability, where instability can be reached in a fraction of a second or after several minutes. Considering the entire European electric power system, there is a broad mix of different controllers with different tasks and responsible stakeholders. Due to this very complex system, it is obvious that there is a great potential for controller conflicts as well as conflicts between stakeholders.

- Load shedding for controlling under frequency situations may lead to de-loading of certain transmission lines. Loss of load in transmission lines determines a reduction of inductive

reactive power consumption which leads to voltage increase and possible tripping of units due to overvoltage protections.

- Low frequency protection of small distributed generations (typically 49 or 49.5 Hz) may determine disconnection of generation units during a low frequency event threatening the frequency stabilization of the remaining units providing primary frequency control.
- Conflicts between technical and market interests are also possible causes for frequency and congestion problems, due to a favourable market price at times where the system is heavily loaded. Governmental regulations also influence the operation of the power system, because of the fact that renewable energy sources cannot always be controlled by the DSO/TSO in order to satisfy grid constraints.
- Possible provision of frequency response from small size units embedded in MV networks (such as small CHP plants) may lead to over-voltages problem at the generator connection point.

Scenarios 2030+ seen from frequency stability perspective

The permanent balance between generation and consumption of electricity is an important prerequisite for stable and reliable system operation, which transmission system operators (TSOs) are required to maintain. In order to guarantee to consumers a sufficiently reliable electricity supply, TSOs keep control power available and provide balancing energy to balancing groups (electricity producers and consumers). There is a close cooperation among TSOs and their control areas that enables the overall amount of control power required to be minimized. Today primary control, secondary control and minutes reserve is procured in an open, transparent and non-discriminatory control power market in accordance with European legislation. A demand for control energy arises if the sum of actual generation differs from the actual load. Differences can arise from the load side (e.g. meteorological influences, daily load forecast error) as well as from the generation side (e.g. power station failures). Procurement is ensured through competitive bidding on a tender basis in control power markets where a large number of suppliers (generators as well as consumers) participate. Small suppliers can also participate in the call for tenders via pooling.

Future scenarios considered for 2030+ (being scenarios selected by e-Highway 2050 [118] project) differ from the current situation. From the frequency stability perspective there are the following factors which may significantly influence the environment for frequency stability:

- New portfolio composition and deployment of generation (weather-dependent small scale generation)
- Increased responsibility of DSOs for provision of grid stabilizing ancillary services, emerging of Aggregators also providing these services
- Large numbers of RES and their capability to take over the role of large synchronous generation regarding frequency control and frequency stability issues.

Further development and deployment in power system information and communication technology, common use of real-time reliability analyses – especially forecasting – of various aspects of system operations and smart grid technologies will further advance the development presented by e-Highway 2050. Table 17 gives an overview of possible scenarios.

Table 17: Scenario impacts on frequency stability.

Future scenario	Influence on frequency stability
Small and Local	In this scenario there is a large decentralized generation in distribution networks of any voltages from HV by MV to LV and reduced large conventional synchronous generation in the transmission networks (spinning reserve). In this scenario necessary control power is procured by conventional (thermal) power plants, albeit at a cost: the required frequency stabilizing reserves increase due to a growing number of uncertain generation that adds to the uncertain demand. Additionally, the originators of this increase in frequency deviations do not themselves contribute to balancing power procurement.
Large fossil fuel with CCS & Nuclear	This scenario is very close to the present model of system operation and frequency stability issues are similar to the present ones and thus will be handled accordingly.
Big & Market	This scenario is similar to the previous one with little difference on the procurement of frequency stabilizing reserve energy. However, capacity-affecting phenomena due to the market interaction cannot be excluded.
100% RES	In this scenario the classical spinning reserve is almost completely substituted by RES that are inverter connected and controlled. A significant level of decentralized RES and large “new use” components has to be coordinated to provide a reliable and stable system operation. In order to avoid frequency instabilities, overcapacities and some forms of (virtual) storages of significant capacities have to be procured.
Large Scale RES & No emissions	This scenario is similar to the “100% RES” scenario. However, large-scale RES offer the potential of higher reliability (through more efficient forecasting) as well as less small-signal stability issues from inverter-to-inverter oscillations. Nuclear provides some means of spinning reserve, which contributes to the overall frequency stability and provides reliable backup capacities.

The significant difference between the present situation and the situation foreseen for the years 2030+ is the growth of new players that are on the one hand responsible for an increase in control power procurement (due to their increased stochastics) but at the same being capable of providing frequency stabilizing ancillary services themselves. Nowadays operational responsibility is carried exclusively by TSOs using own and Generator’s resources. DSOs play only a minor role in frequency controlling/stabilizing ancillary services.

It is obvious that participation of large numbers of RES in frequency control will be possible only when a proper level of information exchange and coordination between the players is enabled that allows for reliable forecasting of these (regionally correlated) ensembles. Of course a successful

coordination is again only possible with the development and deployment of appropriate ICT technologies in power systems.

Recent R&D projects have shown that possible conflicts affecting frequency stability may occur when large numbers of RES provide frequency proportional responses for primary reserve power due to lack of proper coordination among inverters controllers that result in PLLs oscillating against each other. This phenomenon is not yet sufficiently taken into account in technical rules and requirements for pooling strategies/aggregation of RES for this purpose. It cannot be excluded that procedures, which are correct for normal system operation will fail in extreme (unbalanced) RES generation scenarios. In general, scenarios foreseen for frequency control in 2030+ are much more complex than seen today, involving a much larger number of actors responsible for stable system operation.

For frequency stabilizing balancing reserve, being provided by potentially less reliable RES, further progress in applications of forecasting methods and wider use of probabilistic methods in the procurement of renewable-based ancillary services are necessary. Novel concepts of frequency control from RES connected to lower voltage distribution networks need verification concerning their adequacy with respect to frequency stability, reliability, efficiency and costs in order to answer the following questions:

- Will the frequency stabilizing balancing power provided by decentralized generation and “new use” component be suitable for safe and reliable system operation?
- What are the requirements for additional ICT systems for configuring inverter systems to adequately substitute the classical spinning reserve?

These factors play an important role and have to be taken into account when modelling and analysing the possibility of control conflicts and oscillations impacting frequency stability.

5.3.2 Approaches to quantifying controller conflict impact on frequency stability

Frequency stability simulation and instability detection methods

Frequency stability simulation and instability detection requires dynamic modelling simulation. In order to analyse the stability of the system, a set of appropriate differential equations has to be derived according to the dynamic interactions on a given grid, considering both network and inverter electrical models. These dynamic interactions describe the way energy is transmitted and injected through a power grid. Mathematical descriptions of these two processes are needed to derive a valid model of the system that might be used for stability simulation and instability detection. The dynamics of RES energy injection depends on the control systems of the inverters. Modelling the inverters can either be done in great depth, considering detailed descriptions of the different blocks that it consists of. However, describing each inverter extensively does not necessarily provide further information on the stability of the system as a whole. This includes the nonlinearities and switching processes present on the power electronics of the inverter, which are rarely detectable beyond the coupling point. Hence, many times simplified differential models suffice. Methods based on eigenvalue calculations can be used to identify the damping of multi-oscillator systems to assess their instability. Methods of continuous power flow are also applied widely when investigating these kinds of phenomena.

In order to prevent controller conflicts that could lead to frequency instabilities, the specific system with its components and controllers must be investigated. This way, the possibly conflicting behaviour can be simulated and sufficient control strategies and parametrization of the controllers can be determined. For example controllers of inverters for primary control reserve can implement more flexible controller dynamics and/or dynamic control strategies. Simulations to evaluate these concepts have to incorporate detailed dynamic models of inverters as well as grid connections between them in order to take into account transient effects that are relevant to frequency stability. To this end, instabilities due to controller conflicts can be readily inferred from the dynamic controller interactions incorporated in the stability assessment.

5.4 Impact of controller conflict on voltage stability

Overview of voltage stability and instability

According to IEEE/CIGRE classification [90] voltage stability is a subset of overall power system stability. Similarly to angle stability, voltage stability can be divided into large disturbance and small disturbance stability as well as into short term and long term stability. Voltage stability refers to the ability of the power system to maintain steady and acceptable voltages at all buses in the system under normal and disturbed conditions and depends on the ability of the system to supply the active and reactive load through the operating grid. Voltage instability that may result occurs in the form of a progressive fall or rise of voltages at some buses which in turn may cause loss of load, generation, transmission lines and other power systems elements. Impact of voltage instability may be local, which is usually the case of short term phenomena or may be a large area or even a system one, which is mostly the case of long term phenomena. Voltage stability is often associated with angle stability – large disturbance, short term voltage instability is usually the result of angle instability and long term process leading towards voltage instability will, at some point, cause angle instabilities.

From the system point of view the most important is the ability to maintain long term voltage stability. Major large power system failures in the last decades were the result of problems with this kind of stability. Processes leading to instability were triggered by steady growing load and/or by tripping important system elements (generation, transmission lines) in particularly stressed system conditions due to weather or some unplanned system contingencies. The list of 18 large disturbances and blackouts presented in [92] contains up to 10 which are associated with long term voltage stability problems.

The process leading to long term voltage instability can last tens of minutes. At the beginning it is slow – depressing voltages on transmission are observed while voltages in distribution networks are within their ranges thanks to transformer tap changer regulation. The process accelerates when sources of reactive power in the transmission system, mainly synchronous generators, exhaust their capabilities, which means that they stop controlling voltage. From this point it is close to the point when voltage may collapse leading to the blackout of a part of the system.

Long term voltage instability is a complicated process which involves many system components and controls as well as interactions among them. It is spanned from EHV transmission to low voltage distribution. It usually affects stressed and highly loaded systems both with respect to active and reactive power. In many cases a human factor involving lack of inadequate dispatchers' counteraction fostered developing of voltage instability. As an area affected by voltage problems

may involve many decision-making centres (TSOs, DSOs, power plants dispatching) the proper counteraction may be hindered or impossible due to inadequate coordination between the parties.

5.4.1 Identification of conflict scenarios impacting voltage stability

Requirements for modelling voltage instability

Identification of conflict scenarios impacting voltage stability, especially long term voltage stability, requires accurate modelling of power system components. Proper reproduction of static and dynamic behaviours of loads presents major difficulties in modelling. Loads have an impact also on other form of stabilities but for voltage stability, especially long term, their impact seems to be more critical. In addition, load modelling unlike other power system components is not standardized. Modelling of other system components is also more demanding due to significance of various limitations which may become prevalent after the power system has entered stressed conditions. For instance, voltage controllers of synchronous machines in a large area have to be modelled together with the limiters (field current, generator current, under excitation), which is not usually required in other kind of studies.

Below, power system components playing an important role in long term voltage instability development are listed and briefly characterized in the voltage stability context, see Table 18.

Table 18: Component's importance from voltage stability viewpoint.

Model component	Component's importance from voltage stability viewpoint
Loads	A basic load feature for voltage stability is its mainly positive voltage dependence which means that increasing voltage causes increase of load. Among loads particularly important are induction motors which begin to consume more reactive power below some voltage level and if not disconnected can stall, which means large reactive power consumption. Commonly used capacitor compensation of induction motors further aggravates reactive power imbalance at low voltages. Thermostatically controlled loads which at low voltage are switched on for a longer time to achieve required amount of energy play also significant role in developing voltage stability threats. Special attention must be given to plant houseloads which consist mainly from induction motors, because their disconnection due to undervoltage usually means power unit tripping.
Transformers with automatically controlled tap changer	Transformer regulation tries to maintain distribution grid voltages within their normal operational range at the cost of lowering voltages in the transmission network. Taking into account positive voltage dependence of loads it means that power consumption in the distribution is restored at the cost of constantly worsening conditions in the transmission system. Blocking of tap changer regulation is a recognized countermeasure against voltage instability.
Transmission lines	Lightly loaded transmission lines produce reactive power. When the loading is high transmission lines start to consume reactive power and the consumption increases with the square of the line current. In highly stressed conditions a

	<p>possibility of transmission line disconnection due to overcurrent conditions increases. Line disconnection worsens conditions for operating lines and may give rise to cascading of further disconnections.</p>
Large generators and their controls	<p>Nowadays large synchronous generators are critical for maintaining voltage stability due to their capability of fast provision of large reactive power to the transmission network. Low voltage at generator terminals and high turbine power which are typical when voltage stability is in danger significantly limit available reactive power capabilities of the generator. Large generators are equipped with automatic field current limiters. When a field current limiter is activated the generator stops regulating voltage. A similar situation applies to the generator armature current limiters. A generator without voltage regulation will be tripped if voltages will continue to decline. Generator tripping means loss of active and reactive powers which have now to be provided by other generators. This means that these generators will be more stressed and thus more prone to eventual tripping, in other words – cascading of generator disconnections may take place.</p> <p>Reactive power capabilities of synchronous generator are larger if its step-up transformer has tap changer control maintaining generator voltage close to its nominal value.</p>
Synchronous condensers	<p>Synchronous condensers have better characteristics than synchronous generators, which are commonly installed nowadays in systems with large renewable generation. As the synchronous condenser does not produce active power its reactive power capabilities can be respectively larger and limited mainly by a field current limiter which is not so sensitive to decreasing voltage as a generator current limiter.</p>
Shunt capacitor banks	<p>Shunt capacitor banks are commonly used in transmission and distribution systems for voltage regulation purposes. Due to a capacitive reactive power decrease with square of voltage their efficiency is reduced when it is most needed. Active shunt devices like SVC and STATCOM also lose their capabilities for reactive power generation when operating in low voltage conditions. Especially SVC being on its capacitive power generation limit starts to behave like a shunt capacitor.</p>
LCC HVDC	<p>LCC HVDC terminals usually are compensated by shunt capacitors and capacitance present in AC filters. As it was said earlier reactive power generation by capacitor shunts decreasing in square of voltage creates problems at low voltages. Besides, some modes of converter operation (e.g. constant gamma control in inverter) are associated with an increase of reactive power consumption at low voltages. Also, of special importance is the power/voltage instability phenomena, which may occur in low short circuit ratio conditions when HVDC link is operated in constant power mode. Increasing power order causes a rise in DC current which results in a decrease of voltage and thus the DC power starts to decrease and the phenomena aggravates.</p>
VSC	<p>VSC converters are a fundamental component of STATCOM and VSC-based</p>

converters	HVDC links. They provide high controllability of reactive power and voltage, limited by the actual AC voltage and maximum DC voltage. With a decrease of AC voltage, maximum Q capability also diminishes.
Concentrated wind generation	<p>According to national grid codes medium and large wind farms consisting of turbines equipped with inverters usually should have significant capability of voltage and reactive power control at the point of connection. That capability may be used at low voltages assuming that the wind turbines are in operation. Activation of wind farm capabilities requires coordination among operators, for instance regulation of tap changers in transformers supplying distribution grid should be blocked or limited allowing for voltage decreasing in the distribution network.</p> <p>Certainly, areas with large wind generation are less prone for voltage instability. Negative impact of large wind generation on voltage stability may be seen in other parts of the system due to transmission of bulk power and reduction of large synchronous generation.</p>
Dispersed wind and solar generation	Local power generation provide immunity against voltage instability. Sources provided with inverters and able to operate with capacitive reactive power can have additional positive impact assuming that their capabilities will be used in emergency situation.
Protective relay systems	According to [92] at low voltage conditions there is a possibility of maloperation of distance relays (3-rd zone) and overcurrent protections. The mal operations can result in line tripping which deteriorates the situation in a highly loaded voltage depressed system.
Undervoltage load shedding	This protection is not commonly used contrary to underfrequency load shedding. If applied, it is an efficient countermeasure against voltage instability assuming that voltage in the distribution network is allowed to be properly decreased.
Automatic Generation Control	When voltage stability is in danger, there is always a need for more reactive power but very often also for more active power. AGC trying to increase active power of generating unit may limit significantly its reactive power generation capability.
Secondary voltage regulation	Secondary voltage regulation uses generator's AVR (and transformer's tap changer regulation if available) to control voltage at selected high voltage buses in the transmission network instead of generator terminals. In case of voltage stability problems the regulated bus is then closer to the area of eventual low voltages. It means that a generator involved in secondary voltage regulation will provide more reactive power than the same generator controlling its terminal voltage. This is certainly positive. Similar effect can have using voltage control with current compensation which is applied in some systems.

Possible control conflicts affecting voltage stability

A long term process leading to voltage instability has varying speeds and involves many system components and equipment in a large area. In such an environment conflicts among controls are very probable. Based on the classification established in section 5.2.3 a few examples are quoted:

- An point-to-point or point-to-group example of control conflict is a possible interaction between AGC trying to increase the active power of a generator (the action is very likely because voltage instability is usually related to a growing load) when the generator current is close to its limit due to the generator's large reactive power. Consequently the current limiter can be activated and the generator will lose its voltage control capability. Loss of generator voltage controls is a major step towards voltage instability. To avoid the problem the unit should be disconnected from AGC or even allowed to decrease its active power.
- An group-to-group example of conflict among wide area controls can be automatic operation of tap changers in transformers supplying distribution grids which try to keep proper voltage level in the distribution grid and succeed in this task at a cost of decreasing voltages in the transmission network. In case of voltage instability risk this will hamper activation of reactive power reserves available in the distribution grid (the voltage level stays almost normal) and will not allow for possible undervoltage load shedding.
- Another example from this group is a poorly designed secondary voltage control in transmission, which will lead to exhausting reactive reserves in some generators or plants while not properly exploiting other generators or plants.

Possible conflicts may also originate from a human factor, for instance dispatching center avoiding disconnection of loads due to some market prerequisites, which in result may lead to a wide and large blackout.

Scenarios 2030+ seen from voltage stability perspective

Currently in most cases TSOs and transmission networks play a dominant role in the voltage and reactive power control. Using capabilities of large synchronous generators, capacitor batteries, shunt reactors and other equipment operating in the transmission the TSO creates conditions for maintaining correct voltages in all distribution network levels. This is realized by transformers with tap changers regulating their lower voltage thanks to access to fast and flexible reserves of reactive power in the transmission systems.

Future scenarios considered for 2030+ (being scenarios selected by e-Highway 2050 project) differ from the current situation. From the voltage stability perspective there are the following factors which may significantly influence the environment for voltage stability, see Table 19:

- New, different from currently prevailing, portfolio and deployment of generation
- Bulk power AC and DC transfers for large distances
- Increased responsibility of DSOs for provision of ancillary services, emergence of aggregators also providing these services
- Growing role of market
- Large centralized RES and their capability to take over the role of large synchronous generation regarding voltage control and voltage stability issues.
- Further development and deployment in power systems information and communication technology, common use of real time security analyses of various aspects of system operations and smart grid technologies.

Table 19: Scenario impacts on voltage stability.

Future scenario	Influence on voltage stability
Small and Local	<p>In this scenario there is a large amount of decentralized generation in distribution networks of any voltages from HV by MV to LV and reduced large conventional synchronous generation in the transmission. In this scenario a distribution network cannot count on reactive support from the transmission. Moreover in some conditions it will have to provide reactive support needed for safe transmission system operation through transformers connecting both networks. It means that distribution grid must have a sophisticated voltage control system including presumably secondary and maybe even tertiary voltage control.</p>
Large fossil fuel with CCS & Nuclear	<p>The scenario seems to be close to the present model of system operation and voltage stability issues will be likely similar to the present ones. The “new use” component present in the scenario will enable substantial degree of voltage control in MV and LV distribution grids so in general immunity against voltage problems should improve.</p>
Big & Market	<p>The scenario is similar to the previous one but with some significant differences for voltage stability –bigger bulk power transmissions for large distances, less large conventional power plants, more centralized RES and centralized storage. Big power AC flows and less large synchronous generation can create problems for voltage stability. Centralized RES and storage will in turn have positive impact on the voltage stability because it can be assumed that the adequate equipment will have equivalent or better voltage control characteristics than a synchronous generator in a fossil fuel plant.</p>
100% RES	<p>In this scenario conventional synchronous generation is even more limited than in the “Big & Market” scenario in favour of the centralized and decentralized RES and the centralized storage. Such model of generation involves large power transmissions for long distances which if realized by AC may create voltage stability problems. A significant level of decentralized RES and large “new use” components forms possibility for distribution networks to support operation of the transmission network.</p>
Large Scale RES & No emissions	<p>From voltage stability issues this scenario is similar to the “100% RES” scenario – there are large power exchanges but lesser amount of decentralized and centralized RES which are replaced by nuclear generation. The nuclear generation is less elastic than fossil fuel generation which means worse reactive power generation capabilities. In this respect nuclear units may be in practice worse than centralized RES. Positive aspect of nuclear generation is that due to safety reasons new plants are accompanied by large network investments.</p>

The significant difference between the current situation and the situation foreseen for the years 2030+ is the appearance of new players in the field of voltage control and reactive power management. Currently, they are almost exclusively TSOs using own and Generator’s resources.

DSOs play a much more modest role in this activity, ancillary services aggregators are not present yet, moreover voltage and reactive power control are not usually treated as remunerated services. It is obvious that participation of a higher number of players in the field will be effective only then when a proper level of coordination between the players is ensured. Of course a successful coordination is impossible without development and deployment in power systems information and communication technology. In such scenery it seems quite certain, that possible conflicts affecting voltage stability may occur mainly due to lack of proper coordination among players in the system voltage control and reactive power reserves management which are TSOs, DSOs, Generators and Aggregators. Their fields of operation coincide in many points and that usually creates chance of conflict occurrence. It must be remembered that long term voltage stability is treated almost exclusively in low probable states of system operation which are usually out of range of standard security analyses. It is likely that procedures which are suitable for normal system operation will fail in emergency situations.

Conflicts similar to the described earlier for the present power systems will probably also occur in the future. AGC operation may negatively influence reactive power capabilities of generators. Erroneous settings for tap ratio automatic control can disable activation of reactive power capabilities of distribution networks, etc.

Generally, the operational landscape foreseen for voltage and reactive power control in 2030+ is much more complicated than it is presently. It results basically from changes in load and generation but also from increased number of responsible players and an increased emphasis on proper coordination of their activities as well as increased role of information and communication technology.

In the new foreseen power system scenarios, demand and supply regarding reactive power and voltage control will be more variable and will include much more uncertainty. Effective and safe system operation, also regarding voltage control and stability issues, will require further progress in applications of forecasting methods and wider use of probability methods. Besides, new concepts of voltage regulation which assume use of reactive power sources at all voltage levels need verification of their adequacy with respect to system voltage safety, efficiency and costs in order to answer the following questions:

- Will the reactive power sources provided by decentralized generation and “new use” components be sufficient for safe and effective system operation?
- Will there be a need for additional network support in the form of voltage and reactive power controlling equipment like SVC or STATCOM?

It is obvious that these factors cannot be ignored in modelling and analysing possibility of occurrence of control conflicts impacting voltage stability.

5.4.2 Approaches to quantifying controller conflict impact on voltage stability

Voltage stability simulation and instability detection methods

The process leading to long term instability, slow at the beginning, accelerates when the system is being more stressed and approaches the point of instability, which may involve equipment outages due to low voltage conditions and overloads. It means that model should represent both slow and fast dynamic phenomena. For the slow part of process, sequence of steady states achieved by power flow solutions can be a useful tool to model degradation of voltages and a growing system

stress. For fast phenomena dynamic simulation is necessary. It should be noticed however that static methods give better insight into the nature of voltage stability and are better suited for use in everyday operator practice for evaluating voltage stability margins. The static analysis is generally based on power flow methods and may include for instance calculation of P-V and Q-V curves. There are also methods based on eigenvalue calculations of power flow Jacobian which are used to identify the buses most threatened with instability, methods of continuous power flow which enable accurate calculation of instability points and methods based on bifurcation theory used to study phenomena close to the point of voltage collapse.

6 Experiences in controller development, implementation and deployment in demonstration and field test projects

6.1 Introduction

The following section provides an overview of experiences from the ELECTRA partners regarding the realization of controllers in demonstration and field test projects. It summarizes best practices and lessons learned which will provide valuable input for the implementation of control concepts in WP6 and their testing and validation in WP7.

A controller to be implemented and operated in the real power grid has to fulfil special requirements concerning reliability, fault tolerance and robustness. These requirements are usually defined in a requirement specification (incl. hard- and software issues, functional and not non-functional requirements). This section focuses on design, implementation and validation/testing methods for digital controllers.

The fulfilment of requirements can be easily proven in test cases (incl. simulation and laboratory based). Therefore it is logical to develop a validation environment that enables the operation of the developed controller as it is intended to be operated in the field. The following sections describe such a process from the first conceptual phases through to the final release version until the moment the grid operator allows an unattended operation of the controller, see Fig 15.

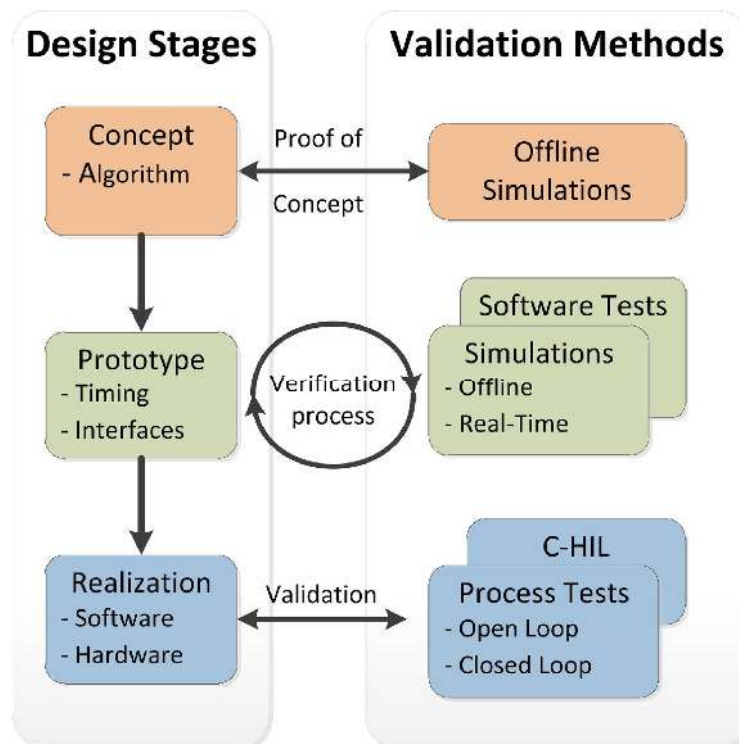

Figure 15: Design, implementation and validation process for Smart Grid systems and applications (simplified view), [110].

6.2 Control algorithm definition and prototyping

In the first step a detailed problem description needs to be defined and ideas of possible solutions for the problems have to be collected, which have to be shaped to one or more prototypes of the controller algorithm.

It makes sense to create a prototyping environment, because usually the implementation for a specific target environment requires significant engineering effort, and the process of testing and gaining experiences is much easier and effective in an environment of reduced complexity. Of course this goes along with a reduction in accuracy, so it has to be clearly decided which components of the environment have to be modelled in which accuracy.

To prove the concept(s), models have to be developed so that the decision can be made if it is worth implementing the controller on a specific target environment, or if the algorithm has to be revised.

6.2.1 Development/collection of environment/plant model

For power grid controller usually the network model is one of the most essential ones. If the network topology has an impact on the control algorithm and strategy, all relevant switching states have to be considered in the network models.

Special attention has to be paid for every component which will be controlled. The models for the controllable components have to be accurate in an early stage of the development process to avoid problems arising in later stages. Relevant are not just component characteristics, but also timing parameters (i.e., non-functional requirements).

Also power/energy profiles of the grid loads and (distributed) generations are necessary. Depending on the function of the controller, it might be necessary to consider power/energy profiles over a specific timespan (typically one year) to consider load/generation conditions typically occurring in the grid. A compromise between accuracy and simulation performance is needed. While for MV grids a time resolution of 10 min is accurate enough, the power flow in LV grids fluctuates significantly, therefore a time resolution of 1 min is preferable. Furthermore, MV simulations can be performed with symmetrical power flow, while LV simulations have to be performed unsymmetrical (4-wire model) at any rate.

Since a one-year-simulation of an LV grid on a time step of one minute could lead to impractical simulation times, some typical days should be chosen for LV grid controller developments. These days can be any combination of summer and winter days, of weekdays and work days, Friday/Saturday and Sunday/holiday, and of good, average and bad weather for simulations with PV. This would reduce in such an example the number of simulated days to 18 (i.e., 2 seasons * 3 weekdays * 3 weather conditions).

In practice, probably power/energy profiles will not be available for every load in the grid. If the models are estimated, a proper estimation target might be that the transformer power flow arising from the estimated load profiles matches a measured power profile in active and reactive power. The creation of realistic power profiles should not be underestimated, especially when realistic power profiles are relevant for a statement about controller efficiency. Any specific information that is available from the grid loads has to be incorporated into the profiles. Due to the introduction of smart meters in Europe, it can be expected to have more detailed and accurate information about the actual load behaviour available in the future.

6.2.2 Development of controller model

If the plant model is finished, the first draft(s) of the model of the controller can be applied to it in simulations. In an iterative process the controller algorithm can be adapted to optimize the

controller behaviour or the control effectiveness. More accurate and detailed models typically lead to better control behaviour (in respect to accuracy, performance as well as the fulfilment of the requirements). At this stage, the chosen modelling language used for the development and modelling of the control algorithm is a secondary issue. The design of the control strategy(s) and corresponding algorithm(s) is of more importance. The used design and modelling language should therefore support fast prototyping with easy and comfortable debugging functionality.

Finally, a functional specification of the controller has to be created with the first simulation results.

6.2.3 Concept testing and validation

At the end of the prototyping phase, the detailed concept for validating the control behaviour has to be defined. If applicable, a reference scenario has to be defined (scenario without controller), which will be compared to the scenario where the controller is active. In simulation, the same grid condition can be repeated arbitrarily and applied to different control strategies. Therefore, the impact of the developed control strategy(s) can be easily presented by comparing them with the reference scenario, if applicable.

In the field trial, only one scenario can be operated at a time, and situations cannot be repeated. Therefore it is necessary to define a strategy to elicit the impact of the introduced controller.

One possibility is to operate in reference scenario, and switch on the controller and evaluate the impact of the control actions by analysing the measurements from the field. This is easy to manage, but it is only one snapshot of many possible situations. It gives no reliable information about the long term impact of the controller. Furthermore, it does not demonstrate the long term reliability of the controller and does not show how the controller reacts in exceptional situations.

Therefore it makes sense to define a schedule that defines periodical switching between the scenarios. For example, a daily cycle of the control operation over a time period of one year may give reliable information about the real impact of the controller on the grid. In this time period, probably many of the typical exceptional situations that can occur in the grid may occur. With these experiences the controller matures and the operational risk is minimized.

The execution of the field test phase and the concept of the validation process have to be discussed at a very early stage, because it is likely that within this discussion new requirements for the controller arise. These new requirements can be implemented very easily if they are considered early, but it will be probably much more costly and engineering effort intensive to retrofit new functionality into the existing controller framework.

6.3 Controller development and implementation

When the requirements of the controller are fixed, the algorithm of the prototype can be migrated into the target environment. While this migration of the algorithm is a simple translation process from the prototype language into the target language, the software environment that is required around the algorithm must not be underestimated. The target environment has to focus much more on robustness, safety and the behaviour in exceptional situations as well as on flexibility. The controller must be customizable and easily configurable, perhaps provide some user interface, some status information and some logging features. The use cases for the network operator have to be defined, so that it is clear which tasks (configuration, maintenance, etc.) the network operator will perform on its own, and which tasks will be done by the manufacturer / developer / solution

provider. When the controller development has finished, the original controller algorithm will only be a very small part of the whole software code.

To guarantee flexibility in the field roll out, it is important that every feature the controller provides can be easily configured, parameterized and adjusted in an external configuration file that is separated from the controller code. This minimizes maintenance efforts, because the same executable binary can be used for multiple grids with different configuration files.

6.3.1 Interface definition for testing environment and target environment

To guarantee the correct function of the controller in the field, an interface has to be defined to which the controller connects. Behind this interface, the test environment or the target environment can be connected in a way that there is no difference for the controller whether it controls the simulation or it controls the real grid components (see figure below). In this architecture, test cases or test suites can be defined to demonstrate the correct behaviour of the controller, see Fig 16.

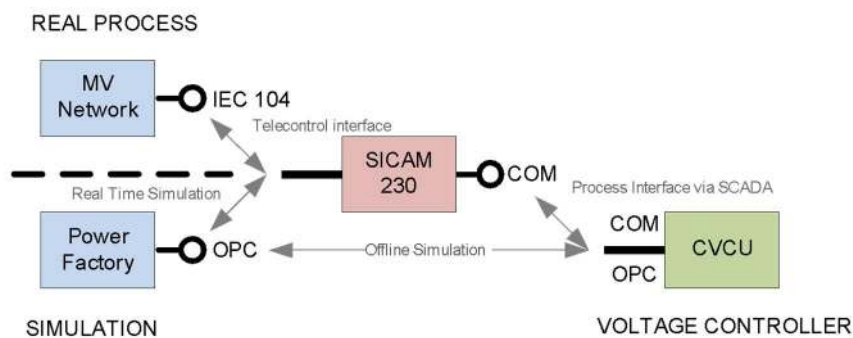

Figure 16: Example architecture for interfacing a voltage controller to operate in test environment and field, [109].

For long term evaluation it can be useful to interface the controller-internal time-base, so that the controller can operate multiple times faster than real time. If all other testing components are also able to speed up their operation behaviour, the simulation can be kept synchronous. With this it can be possible to simulate one year within a few days or even hours, depending on the simulation hardware. It has to be assured that a high speed up factor does not influence the results of the simulation.

To overcome synchronization problems at high speed-up factors, it is possible to define a simulation environment that enables synchronization based on a specific simulation and emulation framework. For this purpose a simulation message bus can synchronize all components that are necessary for simulation. The example shown below enables a synchronized operation of the power grid simulator, the communication network simulator (for an ICT infrastructure that is limited in bandwidth and reliability) and the controller, see Fig 17.

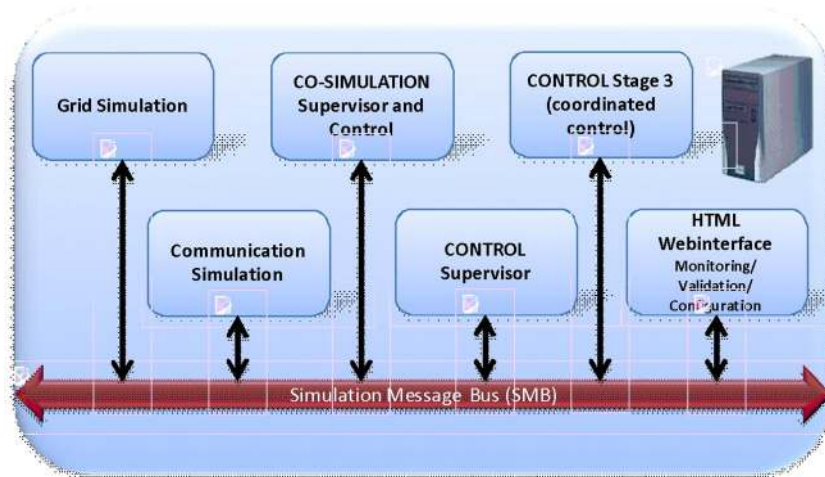

Figure 17: Example architecture for synchronizing several components in a co-simulation environment, [110].

6.3.2 Development of validation scenarios and test cases

Based on the interface presented above, test cases can be defined: at a defined input (through this interface), a defined output has to be produced by the controller (assuming the controller behaviour is deterministic). These tests are called component interface tests or in this case system tests (black box tests), since the whole functionality is tested through the interface.

Ideally, the test cases should be written prior to the code implementation phase. The definition of test cases is often deferred, because it is a laborious task with no variety and little results. But in fact at the end of the development phase they become very important, and the earlier they are ready, the more time can be saved. Even with very good functional specifications, when it comes to the field test phase there will be some small changes necessary in the code, and then it is very important that there is an extensive testing framework available that assures the control function of all components after a change in the code.

In practice, writing system tests in a scientific project can also be disadvantageous. If there are severe changes in controller functionality or in the interface definition necessary (due to unexpected findings), it can happen that all system test cases have to be adapted as well. The same is for new requirements that turn out to be important at a late stage of the development process.

Therefore it is also a possibility to write some component tests for smaller components of the controller framework. This can reduce the number of system tests. If there are severe changes in the code, less system tests have to be adapted, and probably many component tests do not need an update.

6.3.3 Controller development

During the controller development process, the test cases give information about the state of the implementation progress. The less test cases that fail, the more mature the software is. Of course, for software development a revision control software (e.g., subversion, mercurial) should be used. Also an issue and bug tracking system can be useful if more than two people work on the code.

6.3.4 Controller-Hardware-in-the-Loop testing (CHIL)

If the controller development is finished, the tests can be done with the controller operated on the real field test hardware. This is necessary if the field test hardware is limited in CPU performance, memory, or any other I/O. It is also required if the target executable needs to be compiled for a specific operating system platform (microcontroller, Linux, etc.). Therefore power grid (and if necessary the communication flow) is simulated in the test environment, and the controller is connected to this testing environment (via TCP/IP for example), see Fig 18.

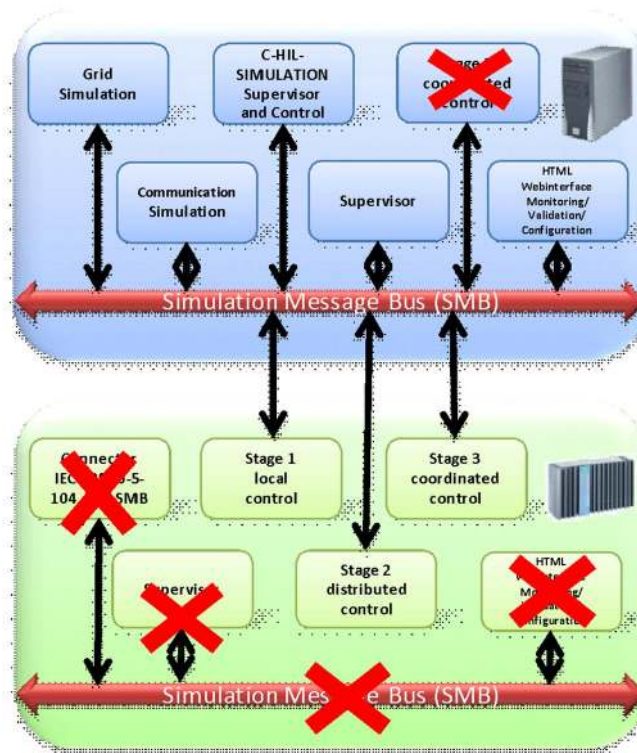

Figure 18: Example configuration for Controller Hardware in the Loop: Coordinated Simulation of power grid, communication, with the controller operated at the field target hardware, [110].

6.4 Controller deployment

Once all tests succeed, the controller is ready for deployment in the field environment. In practice, some early stable releases of the controller will be started in the field with suppressed controller outputs. This helps to get first experiences of field measurement handling – which can be significantly different than the received measurements from simulations, depending on the accuracy of the models.

6.4.1 Open and closed loop operation

It is useful to implement an “open loop” functionality that detains the controller output, so that it can be manually reviewed and individually decided to be released to the grid. The “open loop” mode will be a meaningful feature for the demonstration of the controller behaviour as long as the controller has no functionality implemented that observes the conversion of the sent set values. In this case the open loop will influence the behaviour of the controller, because the controller might react in a different way and consider some controllable components as unavailable when controller output is not sent to the grid.

Depending on the complexity of the controller and the perception of the system operator, the open loop will be operated for a few days up to several weeks. When the controller works satisfactorily, the open loop will be switched to closed loop.

6.4.2 Acceptance test

An acceptance test, where the controller operation will be presented to the system operator, is a good method to get the system operator's confidence. During the acceptance test, the system operator can make suggestions for which situations and what kind of control actions should be demonstrated.

Especially when deploying a controller in MV grids, where many thousands of customers are connected, it may be the case that the system operator is cautious concerning the new solution, and they might have high requirements concerning safety features. A successful acceptance test is necessary but maybe not sufficient for a start of unattended operation. To get a confiding relationship to the system operator, a competent appearance during the project is indispensable.

6.4.3 Start of unattended operation

It is absolutely necessary that the system operator gets a confiding relationship to the solution. Otherwise he will reject the solution. When it comes to unattended operation, the solution should be tested sufficiently so that faulty control reactions can be excluded as good as possible. In practice it will nevertheless happen that something will go wrong, probably some minor issues without having a significant impact on grid supply. Once the system operator gains sufficient confidence in the solution, some minor issues may be accepted.

6.5 Validation of the developed control concept in field test

Finally, at the start of the unattended operation, the procedure of periodic transmission of measurements and logging information must be clarified. At the beginning, a daily data transmission and analysis of the log-files is necessary. Later this can be performed less frequently (e.g. weekly), and finally if the system is mature, a monthly review of deployed controller performance might be suitable.

6.5.1 Analysis of measurement data

It is absolutely necessary that a very user friendly and efficient tool for visualizing and analysing the log-files is built in parallel to the controller deployment in the field. Once the controller is released, there is no possibility for further debugging nor access to the controller's user interface or configuration file. Then it is very important to have a good visualization of what was going on in the grid.

Although many processes can be automated for analysis of measurement data, it is likely that there are some processes that can be checked only manually, since automated data analysis may be error prone. In this case, it is useful to have a visualization tool that can handle a large amount of data logged over a long period of time with sufficiently high resolution..

6.6 Experiences and lessons learned from demonstration and field test projects

The following sections list some important points for the development of a controller for power systems.

6.6.1 Experiences, best practices and lessons learned

The following points briefly summarize important issues which have been discovered during several demo projects:

- The control algorithm is only the “core” of the controller, which is a very small part of the whole code. Requirements like configurability, user interface, measurement pre- and post-processing, robustness and handling of exceptional situations will form the bigger part of the software.
- It is good practice to analyse the way the nature and the quality of measurement values that will be transmitted to the controller in the real asset in an early stage of the project. The earlier the following questions can be answered, the better the rollout will work:
 - If the measurement values come from the grid transmitted over telecontrol: How old are time measurement values that are received? Are there significant delays that could affect the controller operation?
 - Are the received measurements passably synchronous, or are there some heterogeneous transmission latencies?
 - How is the behaviour of each measurement value concerning update rate and averaging period?
 - How long does the controller need to wait until the set values are realized by the controllable components?
- The retrofitting of existing and older grid assets to realise controllability in a new way (for example retrofitting of reactive power control of DG) is time consuming, costly, and does not lead to satisfying results. In contrast, installation of new assets that fulfil the new control requirements leads to good results without much effort.
- Depending on the complexity of the controller, during the first time of field test roll out, there will be several issues that need a lot of interaction between controller developers, technology providers and network operators. This phase is very time consuming for all project partners. Even if significant effort is invested into the modelling and testing of the system, this will not prevent a lot of engineering effort when all components are integrated for the first time in the real grid.

6.6.2 Important points for the ELECTRA developments

In the context of the ELECTRA project and the corresponding controller developments in WP6 as well as the testing/validation in WP7 especially the following points should be taken into account:

- Clearly defined use cases are important for the development of the control strategy and the control algorithm,
- Clearly defined functional and non-functional requirements as well as corresponding interface definitions are essential for a stable and secure operation of the controller,

- Clearly defined test/validation cases are important to test and validate the developed control strategies/algorithms as well as the developed controller software,
- Usage of reversion control software helps to get overview of the controller software development, helps to track different version of the software development and helps to work together in a team of different developers,
- Usage of source code documentation (incl. corresponding tool) should help to document the developed code,
- Usage of issues and bug tracking software should support the development process,
- Usage of coding rules for a unified coding style, and
- Usage of a software development methodology should help to get a better software quality.

7 Conclusions

The different type of flexibility resources, their characteristics, affecting market mechanisms and potential for aggregation were researched using the survey among project partners. In all, 12 partners among WP6 answered to this enquiry. The parameters used to characterise flexibility include the amount of power modulation, the duration, the rate of change, the response time, the location, availability, controllability, etc. Views were also received how these parameters will develop until 2030 and what are the general trends for development of amount and controllability of this resource types. The parameters characterising different flexibility resources provide the technical requirements for applicability of these resources for flexible operation of the grid and their suitability for frequency and voltage control in the future.

Regarding the flexibility of electricity generation, gas turbines and reciprocating engines can be started quickest. The speed of power change is clearly the highest for motors and their minimum power is low. Also steam and combined power plants can be utilised in the relatively quick increasing of the electricity production if they are already running and operating under the nominal power production. Slower power changes are possible also with nuclear power but they cannot be carried out continuously. The regulation characteristics of hydro power are superb in comparison to the other electricity generation methods. Hydro power assorts best for the regulation purpose, particularly for the high-speed regulation. Hydro power is the most profitable alternative in the hourly control level and quicker regulation. Power plants have remote communication and control availability. The technical control characteristics of the combustion motor power plants are insurmountable in comparison to the other thermal power plants.

The controllability of the nuclear power plants is also taken in the account in the development of new reactors, and also the World Nuclear Association (WNA) has given new recommendations for controllability of new power plants. Concerning the future trends the nuclear capacity will be in deployed to base load operation and from the control point of view the main priority is the down regulation.

Wind power besides the sun power is increasing most quickly in the world in the coming years. The modern wind power plants are able to active and reactive power control. In addition of downward control also the upward control is possible to a certain extent, if the wind generation is first curtailed. Upward regulation requires stable wind conditions. The second option for upward regulation is to exploit momentarily the energy stored in the rotational inertia of the rotor. By this way the wind power plants can momentarily support the system frequency. PV plants are available for voltage control so far but also frequency control is possible in the future. Voltage control is normally implemented locally by reactive and active power droop control. Availability for output power and power factor control is continuous, but depends on solar radiation. PV arrays are subject to high changes depending on weather conditions. Therefore, these require balancing power what affects balancing power market and to some extent electricity markets. PV plants have potential for aggregation to virtual power plants and participation in markets as for example balancing markets. Concerning the future trends, PV capacity will increase significantly and this enables the participation in the frequency and voltage regulation especially for plants connected to medium voltage level.

Processes where the electricity consumption can be modulated are suitable for demand response in industry. Industrial loads are normally connected to MV, HV or EHV. They are available for balancing, voltage control at feeder level and frequency support functions. Frequency control schemes can be local and also centralized. Power controllability for upwards regulation depends strongly on the load conditions, but is typically limited. Downwards regulation is more suitable for fixed load power agreements. The control is subject to constraints. EV batteries can be utilized to balance power fluctuations caused by the high penetration of intermittent renewable energy sources in the transmission system level. In the low voltage network, they are available for primary frequency control. The frequency control scheme used is local EV battery discharge or disconnection of EV during low system frequency events. Concerning power controllability the upwards regulation is limited to 100% of stored energy. Various household appliances can participate in demand response in LV network if the device is scheduled for operation with a due time and for example, the device has a fixed load profile like dishwashers, washing machines, tumble dryers, fridges etc. Their typical sizes are from 100 W to 5 kW. Household devices can be aggregated for voltage control at feeder level and also frequency support. An activation of control may result in an unwanted reaction of the unit for some time which is so called rebound effect.

Storage systems can contribute to the frequency and voltage control mechanisms. Charging and discharging of the storage system at the right moments (response within milli-seconds to seconds) can help to preserve the balance between consumption and generation. Storages can also provide secondary and tertiary frequency control. Conventional battery categories today include the most technologically and commercially mature technologies, i.e. Lead Acid batteries (PbA) and nickel based batteries, including Nickel Cadmium (NiCd) and Nickel Metal Hydride (NiMH) batteries. Superconductive magnetic energy storage (SMES) system has fast response and its capability to control active and reactive power makes its potential to stabilise many smart grid applications. The characteristics of supercapacitors are the fast response time in milliseconds, high-energy efficiency (more than 95%), high power density and long shelf and cycle life. Flywheels have high steady inertia and they can support ancillary services like frequency response, provide short time support for spinning reserves and standby reserves. Fast-type ancillary services are not directly relevant application areas for typically slow-response type thermal energy storage, but indirectly for example when installed with local CHP systems, thermal energy storage can participate for providing ancillary services. Pumped hydro storages (PHS) can provide both up and down regulation and can assist with frequency regulation and voltage control. Due to quick start capabilities, PHS can provide black starts and provision of spinning and standing reserves. They are most suitable for transmission application rather than distribution.

Their main goal of the static shunt compensation devices is to maintain desired voltage level by feeding the grid with necessary reactive power. FACTS (Flexible AC Transmission Systems) are power-electronics-based devices that are able to influence such parameters of AC system as impedances (shunt and series), current, voltage, phase angle and power flow. They are very effective in power flow control, voltage control, oscillation damping on various frequencies, voltage and transient stability improvement etc. Dynamic thyristor switched devices will enable grid operators to not only regulate the voltage level but also dynamically respond to grid operating state. Cross-border connections enable each single power system to constitute a part of a large interconnected power system thus improving operational stability and economic efficiency. Cross-border connections based on HVDC converter schemes can play an important role in frequency and voltage support. Besides the voltage band violation problem, three phase voltage unbalance problem could also become an important one in the near future, considering the increasing penetration of PV on separate phases in the LV grid. Tap changing transformers provide a means

of voltage control, typically in the range of $\pm 10\%$. Phase shifting transformers are specially designed transformers for the purpose of changing voltage angle. When installed in series with a line or a transformer they can effectively control power flow. They are going to be an effective solution for minimising congestion problems caused by excessive renewable (uncontrolled) generation.

This report describes appropriate models that characterize the interactions across control boundaries under normal and emergency situations, introducing suitable data rates and models of use by real-time control functions. Boundaries are affected by the electrical grid structure, the demand and generation characteristics and the market. At first, state of art of the frequency and voltage control and regulating reserves are described. Nowadays, the power system is controlled vertically by TSO's and DSO's. Moreover, TSOs are able to keep the power balance since they control the majority of the total generation in the system. Relatively small distributed generation (e.g. 10% in total) in or near the load centres has little influence on the day-ahead prediction of the system load, and therefore little effect on the overall power system control and stability. The voltage levels in an electricity network are maintained by reactive power generation provided by different facilities. Depending on the operational state of electricity networks, the energy generation units, the consumers as well as system components such as lines and transformer, consume or produce reactive power.

In the future power system scheme, TSOS will be able to control significantly lower part of the generation compared to the traditional centralized configuration, and thus they will not be able any more to compensate large deviations in the power balance. Even theoretically a large power imbalance could be faced with accurate day-ahead predictions of decentralized generation and electricity demand of load centers, in practice this will be very difficult due to the intermittent distributed generation profile. Moreover, increased electricity loads and sources such as EVs and residential PV systems, will influence the balance between day-ahead production and consumption schedule and will leave energy markets with higher and less predictable need for balancing power. The traditional power system centralized configuration (top-down vertical control) will be changed into a bi-directional vertically and horizontally integrated control scheme. The abovementioned power system configuration could be depicted as a combination of connected trees of system objectives and functions, decomposing the grid responsibility into cells (subgrids). Each cell can still rely on imports/exports, but these are treated as 'fixed', and the cell is responsible for maintaining its local power balance at all timescales. Cells will be mapped on a hierarchical location and there may be more than one connection between neighbouring cells. In each cell, there will be only one system operator, which will perform reserves management in similar way to the currently that TSOs perform for its Control Area or Control Block. System operator will be responsible to restoring frequency and voltage to their nominal values.

The actors involved in the future frequency control are balance responsible Party (BRP), cell system operator (CSO), cell operational information system (COIS), distribution system operator (DSO). Their respective roles are described and these actors play roles both to technical and market operations. To meet a high quality of supply and the voltage regulation objectives, a hierarchical control structure has been developed and organized in three control levels: primary, secondary and tertiary. The main components are the automatic voltage regulator (AVR), the reactive power (Q) regulator (RQR), the regional voltage regulator (RVR), the national voltage regulator (NVR).

Interactions are modelled under normal and emergency situations. Cell system operator and the BRPs should intercommunicate not only with the generation companies/units inside the cell but

also with neighbouring cells, in order to implement rules for establishing a maximum gradient for total generation output and as far as possible also for demand, at the hourly boundaries, considering ramping period of +/- 5 minutes, to enable the remaining system unbalances (due to modifications of production, consumption and/or exchanges) to be controlled with the Load Frequency Control. Moreover the synchronous inertia control at cell level should be re-examined due to the reduction of the synchronous rotating mass at cell level. If this issue is not addressed, the frequency control reserves may be activated more frequently and much faster. Considering the Sea-of cells concept, the generation units will be smaller and in many cases it will be renewable resources which make them less suitable for frequency control. For that reason a more important role for participation at the demand side will be expected for voltage and frequency control in the future. The demand side can contribute to grid stability, but the contributor's constraints are more strict. Managing these constraints and making sure that the constraints are not violated will be a key element in enabling demand side flexibility to find its way to the market.

The report describes "model based interfaces", where the flexibility user and the flexibility contributor agree on a simplified model which describes the actual behaviour and constraints of the flexibility resource. The principle and the properties of a model based approach are explained by means of the some examples. However, they are difficult to use in practice because all parameters are very specific to the application. But the original equations and constraints can be converted easily in equations and constraints which only contain power and energy. This conversion is called hardware abstraction which has some major advantages. The actual number of flexibility interfaces needed in order to describe all sources of (demand side) flexibility is still under investigation.

With a higher proliferation of flexibility resources and associated controllers, there emerges a greater risk of frequency and voltage instabilities caused by conflicting interactions between these resources. These undesirable interactions can manifest themselves due discrepancies in the controller objectives seen from local and global system perspectives, discrepancies in the operating time windows of said controllers, or indeed the influence of factors such as communications infrastructure performance and system operator errors.

State of the art and system operator experience suggests that conflicting interactions between controllers are already taking place. And their impact ranges from small scale inter-controller oscillations to larger more disruptive system events. Should uncoordinated flexibility control become more commonplace, it is envisaged that the impact of controller conflicts on grid stability can only become more pronounced.

A number of solutions have been proposed in order to mitigate the impact of controller conflicts. These range from coordinated and distributed control strategies to more rigorous system studies and design considerations. However, it is unclear how the influence of the dynamic electricity markets can be managed to avoid undesirable controller behaviour. It is suggested that that the influence of markets can assume a lower priority during emergency situations, however this does not guarantee eliminating other adverse market effects during normal operating situations (e.g. market gaming).

Further research work is required in order to quantify the impact of controller conflict on power system frequency and voltage stability. The approach to which involved two main tasks. First of all it is necessary to identify the controller interactions that are most likely to cause conflicting behaviour. This can be readily achieved through a mapping of flexibility of resources and associated controllers within the SGAM architecture. Secondly, a detailed evaluation of controller behaviour through simulation is needed to understand the extent of the impact of aforementioned interactions on grid stability. For the evaluation to be meaningful from an ELECTRA perspective,

the conducted simulations must adhere to the use cases developed under WP3 and WP4. The methodology presented in the report for the identification of controller conflict encompasses these two tasks and outlines the necessary pre-requisite work from the rest of the project for formulating this key understanding of controller conflict and its impact on grid stability.

The report provides also an overview of experiences from the ELECTRA partners regarding the realization of controllers in demonstration and field test projects. It summarizes best practices and lessons learned which will provide valuable inputs for the implementation of control concepts and their testing and validation. The main requirements for controllers are reliability, fault tolerance and robustness. The controller algorithm needs a detailed problem description to be defined and ideas of possible solutions for the problems have to be collected, which have to be shaped to one or more prototypes of the controller algorithm. For power grid controller usually the network model is one of the most essential ones. If the network topology has an impact on the controller, all relevant switching states have to be considered in the network models. The models for the controllable components have to be very accurate and very often the power profiles of the grid loads and generations are necessary. If the environment model is finished, the first draft(s) of the model of the controller can be applied to it in simulations. In an iterative process the controller algorithm can be adapted to optimize the controller behaviour or the control effectiveness. At the end of the prototyping phase, the detailed concept for validating the effect of the controller has to be defined. If applicable, a reference scenario has to be defined (scenario without controller), which will be compared to the scenario where the controller is active.

When the requirements on the controller are fixed, the algorithm of the prototype can be migrated into the target environment. To guarantee flexibility in field rollout, it is important that every feature the controller provides can be easily configured, parameterized and adjusted in an external configuration file that is separated from the controller code. This minimizes maintenance efforts, because the same executable binary can be used for multiple grids with different configuration files. To guarantee the correct function of the controller in the field, an interface has to be defined to which the controller connects. Based on the interface, test cases can be defined: At a defined input (through this interface), a defined output has to be given by the controller (assuming the controller behavior is predictive). These tests are called component interface tests or in this case system tests (blackbox tests), since the whole functionality is tested through the interface. During the controller development process, the test cases give information about the state of the implementation progress. The less test cases fail, the more mature the software is. If the controller development is finished, the tests can be done with the controller operated on the real field test hardware.

Once all tests succeed, the controller is able for deployment in the field environment. In practice, some early stable releases of the controller will be started in the field with suppressed controller outputs. It is useful to implement an “open loop” functionality that detains the controller output, so that it can be manually reviewed and individually decided to be released to the grid. When the controller works satisfactory, the open loop will be switched to closed loop. During the acceptance test, the system operator can make suggestions which situations and what kind of control actions should be demonstrated.

In the final phase, the developed control concept will be validated in the field tests. At the start of the unattended operation, the procedure of periodically transmission of measurement- and logging information must be clarified. At the beginning, a daily sending and analysis of the log-files is necessary, later it will come to a weekly interval, and finally if the system is mature, a monthly

rhythm might be suitable. The report describes also what kind of experiences is possible to get and what is possible to learn from demonstration and field test projects.

8 References

- [1] ELECTRA D3.1 available at www.electrairp.eu
- [2] <http://www.electrairp.eu> (ELECTRA IRP web site)
- [3] Aalto, A., Honkasalo, N., Järvinen, P., Jääskeläinen, J., Raiko, M., Sarvaranta, A. 2012. Energy Industry and Fingrid Oyj, 2012. How to increase flexibility in the power system. ÅF-Consult Limited, 123 p (in Finnish).
- [4] WWW.fingrid.fi; Marttinen, M. 2010. Assessing of the lifetime for excitation system of hydropower generator. Master of Science thesis. Tampere University of Technology. 54 p. [In Finnish]
- [5] 2012 - Dati Statistici sull'Energia Elettrica in Italia Terna S.p.A. [In Italian]
- [6] <http://www.admie.gr/en/operations-data/registers/generation-unit-register/production-units-in-units-register/>
- [7] http://www.resoffice.gr/file/reg/stats_static.html
- [8] Chi-Jen Yang, "Pumped Hydroelectric Storage" (<http://people.duke.edu/~cy42/PHS.pdf>)
- [9] Project stoRE: "D5.1 – GREECE Overview of the electricity system status and its future development scenarios – Assessment of the energy storage infrastructure needs" (http://www.store-project.eu/en_GB/target-country-results)
- [10] http://ast.lv/files/ast_files/gadaparskzinoj/PSO_ikgadejais_novertejuma_zinojums_2012.pdf: The transmission system operator's annual assessment report [In Latvian]
- [11] <http://www.pse.pl> - PSE - Polish Power Transmission System Operator
- [12] <http://www.cire.pl> - Power Market Information Center
- [13] Electricity Generation Co. (EÜAŞ) Installed Capacity and Electricity Generation Data, Turkish Electricity Transmission Co. Installed Capacity Data, Republic of Turkey Energy Market Regulatory Authority; <http://www.emra.org.tr/>
- [14] Elforsk (2011). Lastföljning I kärnkraftverk – Möjliga effektregeringar for svenska kärnkraftverk utifrån ett internationellt perspektiv. Elforsk rapport.
- [15] Polish Nuclear Power Programme – adopted by by Polish Government on January 28th, 2014, http://www.mg.gov.pl/files/upload/19990/PPEJ_2014_01_28_po_RM.pdf
- [16] [Http://www.motiva.fi/myllarin_tuulivoima/windpower%20web/en/tour/wtrb/powerreg.htm](http://www.motiva.fi/myllarin_tuulivoima/windpower%20web/en/tour/wtrb/powerreg.htm)
- [17] <http://www.ure.gov.pl/uremapoze/mapa.html>
- [18] http://www.resoffice.gr/file/reg/stats_static.html
- [19] http://www.desmie.gr/fileadmin/user_upload/Files/news/432011_8.pdf
- [20] <http://www.ypeka.gr/LinkClick.aspx?fileticket=vBWJVY3FdTk%3D&...>
- [21] ENERGINET.DK Technical regulation 3.2.5 for wind power plants with a power output greater than 11 kW
- [22] **Scenarios – Direccção Geral de Energia e Geologia "Relatório de Monitorização da Segurança de Abastecimento do Sistema Eléctrico Nacional 2013-2030", Março de 2013.**
- [23] The Impact of Control Technology, T. Samad and A.M. Annaswamy (eds.), 2011. Available at www.ieeecss.org
- [24] CCSE Cassa Conguaglio Sistemna Elettrico. http://www.ccse.cc/site/informazioni/servizio-interrompibilita#_ftnref1
- [25] M. Yunfei, W. Jianzhong, J. Ekanayake, N. Jenkins, and J. Hongjie, "Primary Frequency Response From Electric Vehicles in the Great Britain Power System," Smart Grid, IEEE Transactions on, vol. 4, pp. 1142-1150, 2013.
- [26] W. Kempton and J. Tomić, "Vehicle-to-grid power implementation: From stabilizing the grid to supporting large-scale renewable energy," J. Power Sources, vol. 144, no. 1, pp. 280–294, Jun. 2005.
- [27] W. Kempton and J. Tomic, "Vehicle-to-grid power fundamentals: Calculating capacity and

- net revenue,” *J. Power Sources*, vol. 144, no. 1, pp. 268–279, 2005.
- [28] Y. Mu, J. Wu, J. Ekanayake, N. Jenkins, and H. Jia, “Primary Frequency Response From Electric Vehicles in the Great Britain Power System,” *Smart Grid, IEEE Transactions on*, vol. 4, no. 2, pp. 1142–1150, 2013.
- [29] “Low carbon innovation coordination group, Technology Innovation Needs Assessment: Electricity Networks and Storage,” 2012.
- [30] C. K. Divya, J. Østergaard, E. Larsen, C. Kern, T. Wittmann, and M. Weinhold, “Integration of electric drive vehicles in the Danish electricity network with high wind power penetration,” *Eur. Trans. Electr. Power*, vol. 20, no. 7, pp. 872–883, 2010.
- [31] J. Østergaard, A. Foosnæs, Z. Xu, T. A. Mondorf, C. A. Andersen, S. Holthusen, T. Holm, M. F. Bendtsen, and K. Behnke, “Electric vehicles in power systems with 50% wind power penetration: the Danish case and the EDISON programme,” in *European Conference Electricity & Mobility*.
- [32] E. Larsen, D. K. Chandrashekhara, and J. Ostergard, “Electric vehicles for improved operation of power systems with high wind power penetration,” in *Energy 2030 Conference, 2008. ENERGY 2008. IEEE, 2009*, pp. 1–6.
- [33] J. R. Pillai and B. Bak-Jensen, “Integration of Vehicle-to-Grid in the Western Danish Power System,” *Sustainable Energy, IEEE Transactions on*, vol. 2, no. 1, pp. 12–19, 2011.
- [34] R. J. Bessa and M. A. Matos, “Economic and technical management of an aggregation agent for electric vehicles: a literature survey,” *Eur. Trans. Electr. Power*, vol. 22, no. 3, pp. 334–350, 2012.
- [35] T. G. San Román, I. Momber, M. R. Abbad, and Á. Sánchez Miralles, “Regulatory framework and business models for charging plug-in electric vehicles: Infrastructure, agents, and commercial relationships,” *Energy Policy*, vol. 39, no. 10, 2011.
- [36] C. Søndergren, *Edison project: Electric Vehicles in Future Market Models*. 2011.
- [37] K. Clement-Nyns, E. Haesen, and J. Driesen, “The Impact of Charging Plug-In Hybrid Electric Vehicles on a Residential Distribution Grid,” *IEEE Trans. Power Syst.*, vol. 25, no. 1, pp. 371–380, Feb. 2010.
- [38] O. Sundstrom and C. Binding, “Flexible Charging Optimization for Electric Vehicles Considering Distribution Grid Constraints,” *IEEE Trans. Smart Grid*, vol. 3, no. 1, pp. 26–37, 2012.
- [39] J. Hu, S. You, M. Lind, and J. Ostergaard, “Coordinated Charging of Electric Vehicles for Congestion Prevention in the Distribution Grid,” *Smart Grid, IEEE Trans.*, vol. 5, no. 2, pp. 703–711, 2014.
- [40] J. A. P. Lopes, F. J. Soares, and P. M. R. Almeida, “Integration of electric vehicles in the electric power system,” *Proc. IEEE*, vol. 99, no. 1, pp. 168–183, 2011.
- [41] N. O’ Connel, Q. Wu, J. Østergaard, A. Nielsen, Cha S, and Y. Ding, “Electric vehicle (EV) charging management with dynamic distribution system tariff,” in *proceeding of 2011 ISGT, 2011*.
- [42] A. Ipakchi, “Demand side and distributed resource management—A transactive solution,” in *Power and Energy Society General Meeting, 2011 IEEE, 2011*, pp. 1–8.
- [43] B. Biegel, P. Andersen, J. Stoustrup, and J. Bendtsen, “Congestion Management in a Smart Grid via Shadow Prices,” in *Proceedings of the 8th IFAC Symposium on Power Plant and Power System Control, 2012*.
- [44] J. Hu, S. You, C. Si, M. Lind, and J. Østergaard, “Optimization and control method for smart charging of EVs facilitated by Fleet operator: review and classification,” *Int. J. Distrib. Energy Resour.*, vol. 10, no. 1, pp. 31–56, 2014.
- [45] V. Lakshmanan, K. Gudmand-Høyer, M. Marinelli, A. M. Kosek, and P. B. Nørgård, “Energy shift estimation of demand response activation on domestic refrigerators – A field test study,”
- [46] *Universities Power Engineering Conference (UPEC), 2014 Proceedings of the 49th International*, pp.1-6, Cluj Napoca, 2-5 Sep. 2014
- [47] Department of Energy and Climate Change (2012) “Demand side response in the domestic sector- a literature review of major trials (Final Report)”, UK.

- [48] K. Samarakoon, J. Ekanayake, and N. Jenkins, "Investigation of Domestic Load Control to Provide Primary Frequency Response Using Smart Meters," *Smart Grid, IEEE Transactions on*, vol. 3, pp. 282-292, 2012.
- [49] Elisabeth Lemaire, Nicolas Martin, Per Nørgård, Erik de Jong, Roald de Graaf, Jasper Groenewegen, Efsthathia Kolentini, and Stathis Tselepis, "European White Book on Grid-Connected Storage, DRAFT," CEA INES, Nov. 2011.
- [50] ENTSO-E, "UCTE OH – Policy 1: Load-Frequency Control - Final Version (approved by SC on 19 March 2009)." 2009.
- [51] S. Skarvelis-Kazakos, E. Rikos, E. Kolentini, L. M. Cipcigan, and N. Jenkins, "Implementing agent-based emissions trading for controlling Virtual Power Plant emissions," *Electric Power Systems Research*, vol. 102, pp. 1–7, Sep. 2013.
- [52] W. R. Yang, M. H. Hu, G. W. Jhang, Z. Y. He, K. Y. Huang, C. S. Wang, L. R. Chen, T. Y. Guo, and C. P. Young, "Flywheel energy storage system for voltage sag compensation," in *International Conference on Power Electronics and Drive Systems, 2009. PEDS 2009, 2009*, pp. 956–961.
- [53] Alanen, R., Appetecchi, G., Conte, M., De Jaeger, E., Graditi, G., Jahren, S., Martini, L., Mazman, M., Micolano, E., Mulder, G., Nielsen, T., Sandu., Svensson., Unur, E., Van Baal, J. 2012. D4.1 Electrical Energy Storage Technology Review. 110 p.
- [54] TERNA s.p.a. Sistemi di accumulo di energia di tipo elettrochimico per la gestione efficiente delle fonti rinnovabili non programmabili - A.C. Tortora, E. Senatore, L. Apicella , R. Polito (Italian,) - Terna Storage
- [55] Deane J.P., B.P. Ó Gallachóir, E.J. McKeogh, 2010, "Techno-economic review of existing and new pumped hydro energy storage plant", *Renewable and Sustainable Energy Reviews* 14(4): 1293–1302. doi:10.1016/j.rser.2009.11.015.
- [56] National Grid Electricity Transmission, "Fast Reserve Service Description," 2013.
- [57] National Grid Electricity Transmission, "Short Term Operating Reserve: General Description of the Service," 2014.
- [58] National Grid, "UK Future Energy Scenarios," 2014.
- [59] M. Coppo and R. Turri, "Voltage Management in Unbalanced Low Voltage Networks Using a Decoupled Phase-Tap-Changer Transformer," in *Power Engineering Conference (UPEC), 2014 49th International Universities* , vol., no., pp.1,6, 2-5 Sept., 2014.
- [60] Dieter Dohnal: On-Load Tap-Changers For Power Transformers PB 25 2/06 EN – On-load tap-changers for powertransformers - F0126405 - 09/13 - dp - Maschinenfabrik Reinhausen GmbH 2013.
- [61] <http://www.edsoforsmartgrids.eu/category/position-papers/>
- [62] UCTE OH – Policy 1: Load-Frequency Control.
- [63] UCTE OH – Policy 3: Operational Security.
- [64] EDSO for Smart Grids, "Flexibility: The role of DSOs in tomorrow's electricity market" May 2014, ENTSO-E operation handbook
- [65] A joint EURELECTRIC – ENTSO-E response paper: "Deterministic frequency deviations – root causes and proposals for potential solutions", December 2011
- [66] Daniel Kirschen, Yann Rebours "A Survey of Definitions and Specifications of Reserve Services".
- [67] UCTE AD-HOC GROUP 'Frequency Quality Investigation' Excerpt of the Final Report".
- [68] H. F. Illian. 2010. Frequency Control Performance Measurement and Requirements", Lawrence Berkley Laboratory. 32 p. <http://escholarship.org/uc/item/2d63w2f7#page-3>.
- [69] entso-e, "Continental Europe Operation Handbook"
- [70] entso-e, "The Harmonised Electricity Market Role Model", version 2011-01, available at https://www.entsoe.eu/fileadmin/user_upload/edi/library/role/role-model-v2011-01.pdf
- [71] EU Commission Task Force for Smart Grids, "Expert Group 3: Roles and Responsibilities of Actors involved in the Smart Grids Deployment", EG3 Deliverable 04. April 2011 available at http://ec.europa.eu/energy/gas_electricity/smartgrids/doc/expert_group3.pdf
- [72] Daniel E. M. Bondy, Lars Henrik Hansen, Kai Heussen, Tarnowski Vestas: "Operational Scenario: Manual Regulating Power", STRATEGIC PLATFORM FOR INNOVATION AND RESEARCH IN INTELLIGENT POWER [IPOWER]
- [73] P. H. Nguyen, W. L. Kling, and P. F. Ribeiro, "A Game Theory Strategy to Integrate

- Distributed Agent-Based Functions in Smart Grids," Smart Grid, IEEE Transactions on, vol. 4, pp. 568-576, 2013.
- [74] H. E. Z. Farag and E. F. El-Saadany, "A Novel Cooperative Protocol for Distributed Voltage Control in Active Distribution Systems," Power Systems, IEEE Transactions on, vol. PP, pp. 1-1, 2012.
- [75] Y. P. Agalgaonkar, B. C. Pal, and R. A. Jabr, "Distribution Voltage Control Considering the Impact of PV Generation on Tap Changers and Autonomous Regulators," Power Systems, IEEE Transactions on, vol. 29, pp. 182-192, 2014.
- [76] S. Dahal, N. Mithulanathan, and T. K. Saha, "Assessment and Enhancement of Small Signal Stability of a Renewable-Energy-Based Electricity Distribution System," Sustainable Energy, IEEE Transactions on, vol. 3, pp. 407-415, 2012.
- [77] J. Nutaro and V. Protopopescu, "The Impact of Market Clearing Time and Price Signal Delay on the Stability of Electric Power Markets," Power Systems, IEEE Transactions on, vol. 24, pp. 1337-1345, 2009.
- [78] S. Gill, I. Kockar, and G. W. Ault, "Dynamic Optimal Power Flow for Active Distribution Networks," Power Systems, IEEE Transactions on, vol. 29, pp. 121-131, 2014.
- [79] E. Wieben, T. Kumm, E. Hohn, M. Rohr, and M. Stadler, "The 5% Approach as Building Block of an Energy System dominated by Renewables," Proceedings of the 28th Conference on Environmental Informatics - Informatics for Environmental Protection, Sustainable Development and Risk Management, 2014.
- [80] S. Lehnhoff, T. Klingenberg, M. Blank, M. Calabria, and W. Schumacher, "Distributed coalitions for reliable and stable provision of frequency response reserve," in Intelligent Energy Systems (IWIES), 2013 IEEE International Workshop on, 2013, pp. 11-18.
- [81] F. Andren, B. Bletterie, S. Kadam, P. Kotsampopoulos, and C. Bucher, "On the Stability of local Voltage Control in Distribution Networks with a High Penetration of Inverter-Based Generation," Industrial Electronics, IEEE Transactions on, vol. PP, pp. 1-1, 2014.
- [82] T. Deutsch, F. Kupzog, A. Einfalt, and S. Ghaemi, "Avoiding Grid Congestions with Traffic Light Approach and the Flexibility Operator," presented at the CIRED Workshop, 2014.
- [83] H. Hansen, L. H. Hansen, Jo, x, H. hannsson, H. H. Holm-Hansen, et al., "Coordination of system needs and provision of services," in Electricity Distribution (CIRED 2013), 22nd International Conference and Exhibition on, 2013, pp. 1-4.
- [84] F. Sossan and M. Marinelli, "An auto tuning substation peak shaving controller for congestion management using flexible demand," in Power Engineering Conference (UPEC), 2013 48th International Universities', 2013, pp. 1-5.
- [85] C. T. 38.02.16, "Technical Brochure on Impact of the Interaction among Power System Controls," 2000.
- [86] Z. Xiaohu and C. Chen, "Maximum available power of multi-infeed hvdc system analysed by sensitivity method," Generation, Transmission & Distribution, IET, vol. 8, pp. 473-479, 2014.
- [87] S. Gill, G. W. Ault, and I. Kockar, "The optimal operation of energy storage in a wind power curtailment scheme," in Power and Energy Society General Meeting, 2012 IEEE, 2012, pp. 1-8.
- [88] E. E. Bernabeu, J. Thorp, and V. Centeno, "Methodology for a Security/Dependability Adaptive Protection Scheme Based on Data Mining," Power Delivery, IEEE Transactions on, vol. 27, pp. 104-111, 2012.
- [89] NGET, "Report of the national grid investigation into the frequency deviation and automatic demand disconnection that occurred on the 27th May 2008," 2009.
- [90] ENTSO-E, "Justification of the FRT- Requirement for Type B Units in the RfG Network Code," meeting with DSO Technical Expert Group," 2012.
- [91] "Definition and Classification of Power System Stability", IEEE/CIGRE Joint Task Force on Stability Terms and Definitions, IEEE TRANSACTIONS ON POWER SYSTEMS, VOL. 19, NO. 2, MAY 2004
- [92] CIGRE Task Force 38.02.14 Rep., Analysis and Modeling Needs of Power Systems Under Major Frequency Disturbances, Jan. 1999.
- [93] P. Kundur, D. C. Lee, J. P. Bayne, and P. L. Dandeno, "Impact of turbine generator controls on unit performance under system disturbance conditions," IEEE Trans. Power

- Apparatus and Systems, vol. PAS-104, pp. 1262–1267, June 1985.
- [94] Q. B. Chow, P. Kundur, P. N. Acchione, and B. Lautsch, “Improving nuclear generating station response for electrical grid islanding,” IEEE Trans. Energy Conversion, vol. EC-4, pp. 406–413, Sept. 1989.
- [95] P. Kundur, “A survey of utility experiences with power plant response during partial load rejections and system disturbances,” IEEE Trans. Power Apparatus and Systems, vol. PAS-100, pp. 2471–2475, May 1981.
- [96] IEEE Committee Report, “Guidelines for enhancing power plant response to partial load rejections,” IEEE Trans. Power Apparatus and Systems, vol. PAS-102, pp. 1501–1504, June 1983
- [97] S. Lehnhoff, M. Blank, T. Klingenberg, M. Calabria, W. Schumacher, “Distributed Coalitions for Reliable and Stable Provision of Frequency Response Reserve – An Agent-based Approach for Smart Distribution Grids”, Proceedings of the IEEE International Workshop on Intelligent Energy Systems (IWIES), IEEE Press, 2013
- [98] A. Nieße, S. Lehnhoff, M. Tröschel, M. Uslar, C. Wissing, H.-J. Appelrath, M. Sonnenschein: „Market-Based Self-Organized Provision of Active Power and Ancillary Services: An Agent-Based Approach for Smart Distribution Grids”, Proceedings of IEEE COMPENG, 2012.
- [99] J. Machowski, J. W. Bialek, and J. R. Bumby: “Power system dynamics: stability and control.” Chichester: Wiley, 2008. Y. Wang, X. Zhu, L. Xu, and H. Li, “Contribution of VSC-HVDC connected wind farms to grid frequency regulation and power damping,” in IECON 2010-36th Annual Conference on IEEE Industrial Electronics Society, 2010, pp. 397–402.
- [100] UCTE - union for the co-ordination of transmission of electricity (now ENTSO-E - European Network of Transmission System Operators for Electricity), “Final Report System Disturbance on 4 November 2006,” pp.1-85, 30 Jan 2007.
- [101] P. Kundur: “Power System Stability and Control”, p. 1081, 1994
- [102] E. Wieben, T. Kumm, E. Hohn, M. Rohr, M. Stadler, “The 5% Approach as Building Block of an Energy System dominated by Renewables”, Proceedings of the 28th EnviroInfo 2014 Conference, Oldenburg, Germany, September 10-12, 2014
- [103] “Definition and Classification of Power System Stability”, IEEE/CIGRE Joint Task Force on Stability Terms and Definitions, IEEE TRANSACTIONS ON POWER SYSTEMS, VOL. 19, NO. 2, MAY 2004
- [104] “Recommendations for Defence Plans in the Continental Europe Synchronous Area” ENTSO_E RGCE 2011
- [105] “Defence Plan Against Extreme Contingencies” Task Force C2.02.24 CIGRE 2007
- [106] “Coping with Limits for Very High Penetrations of Renewable Energy” CIGRE 2013 WG C1/C2/C6.18
- [107] “Voltage Stability” C. W. Taylor, McGraw-Hill, Inc.1994.
- [108] F. Andren et al, “A Development and Validation Environment for Real-Time Controller-Hardware-in-the-Loop Experiments in Smart Grids”; International Journal of Distributed Energy Resources and Smart Grids, Special Issue on Hardware-in-the-loop Testing, Volume 9 (2013), 1 (2013) January-March 2013; S. 27 - 50.
- [109] M. Stifter et al, “DG DemoNet Validation: Voltage Control from Simulation to Field Test”, IEEE Innovative Smart Grids Technologies, Manchester, 2011
- [110] M. Faschang et al, “Controller Hardware in the Loop Approaches Supporting Rapid Prototyping of Smart Low Voltage Grid Control”, IEEE Innovative Smart Grids Technologies Europe, Istanbul, 2014
- [111] B. Bagen, D. Jacobson, G. Lane, and H. M. Turanli, “Evaluation of the performance of back-to-back HVDC converter and variable frequency transformer for power flow control in a weak interconnection,” in Power Engineering Society General Meeting, 2007. IEEE, 2007, pp. 1–6.
- [112] F. I. Bakhsh and D. K. Khatod, “Variable Frequency Transformer-State of the art review,” in Energy Efficient Technologies for Sustainability (ICEETS), 2013 International Conference on, 2013, pp. 1012–1017.
- [113] http://www.mitsubishi-motors.com/publish/pressrelease_en/corporate/2014/news/detail0954.html

- [114] Five small variable-frequency **transformers** with a total power rate of 25 MVA were in use at **Neuhof Substation**, Bad Sachsa, Germany for coupling power grids of former East and **West Germany** between 1985 and 1990.
- [115] Langlois Substation in **Québec, Canada** ($45^{\circ}17'13.76''\text{N}$ $74^{\circ}0'56.07''\text{W}$) installed a 100 MW variable-frequency transformer in 2004 to connect the asynchronous grids in Québec and the **northeastern United States**.
- [116] AEP Texas installed a 100 MW VFT substation in **Laredo, Texas, United States** ($27^{\circ}34'13.64''\text{N}$ $99^{\circ}30'34.98''\text{W}$) in early 2007. It connects the power systems of **ERCOT** (in the United States) to **CFE** (in Mexico). (See **The Laredo VFT Project**.)
- [117] Smaller VFTs are used in large land-based **wind turbines**, so that the turbine rotation speed can vary while connected to an **electrical distribution** grid.
- [118] <http://www.e-highway2050.eu/e-highway2050/>

9 Disclaimer

The ELECTRA project is co-funded by the European Commission under the 7th Framework Programme 2013.

The sole responsibility for the content of this publication lies with the authors. It does not necessarily reflect the opinion of the European Commission.

The European Commission is not responsible for any use that may be made of the information contained therein.