



GLOBAL JOURNAL OF RESEARCHES IN ENGINEERING: J
GENERAL ENGINEERING
Volume 11 Issue 5 Version 1.0 July 2011
Type: Double Blind Peer Reviewed International Research Journal
Publisher: Global Journals Inc. (USA)
Online ISSN: 0975-5861

Detection of Mechanical Deformation in Old Aged Power Transformer Using Cross Correlation Co-Efficient Analysis Method

By Asif Islam, Aminul Hoque

Bangladesh University of Engineering & Technology, Dhaka, Bangladesh

Abstracts – Detection of minor faults in power transformer active part is essential because minor faults may develop and lead to major faults and finally irretrievable damages occur. Sweep Frequency Response Analysis (SFRA) is an effective low-voltage, off-line diagnostic tool used for finding out any possible winding displacement or mechanical deterioration inside the Transformer, due to large electromechanical forces occurring from the fault currents or due to Transformer transportation and relocation. In this method, the frequency response of a transformer is taken both at manufacturing industry and concern site. Then both the response is compared to predict the fault taken place in active part. But in old aged transformers, the primary reference response is unavailable. So Cross Correlation Co-Efficient (CCF) measurement technique can be a vital process for fault detection in these transformers. In this paper, theoretical background of SFRA technique has been elaborated and through several case studies, the effectiveness of CCF parameter for fault detection has been represented.

Keywords : *Sweep Frequency Response Analysis, Mechanical Displacements, Radial Deformation, Axial Deformation, Core Damage, Cross Correlation Co-efficient, Power Transformer.*

GJRE-J Classification : *FOR Code: 090607*



Strictly as per the compliance and regulations of:



Detection of Mechanical Deformation in Old Aged Power Transformer Using Cross Correlation Co-Efficient Analysis Method

Asif Islam^α, Aminul Hoque^Ω

Abstract - Detection of minor faults in power transformer active part is essential because minor faults may develop and lead to major faults and finally irretrievable damages occur. Sweep Frequency Response Analysis (SFRA) is an effective low-voltage, off-line diagnostic tool used for finding out any possible winding displacement or mechanical deterioration inside the Transformer, due to large electromechanical forces occurring from the fault currents or due to Transformer transportation and relocation. In this method, the frequency response of a transformer is taken both at manufacturing industry and concern site. Then both the response is compared to predict the fault taken place in active part. But in old aged transformers, the primary reference response is unavailable. So Cross Correlation Co-Efficient (CCF) measurement technique can be a vital process for fault detection in these transformers. In this paper, theoretical background of SFRA technique has been elaborated and through several case studies, the effectiveness of CCF parameter for fault detection has been represented.

Keywords : Sweep Frequency Response Analysis, Mechanical Displacements, Radial Deformation, Axial Deformation, Core Damage, Cross Correlation Co-efficient, Power Transformer

I. INTRODUCTION

Nowadays, reliability is an inevitable part of power system studies and operation, due to significant increase in the number of industrial electrical consumers. Power transformer is one of the major and critical elements in power system [1] in the area of reliability issue, since their outage may result in costly and time - consuming repair and replacement. Power transformers are specified to withstand the mechanical forces arising from both shipping and subsequent in-service events, such as faults and lightning. Once a transformer is damaged either heavily or slightly, the ability to withstand further incidents or short circuit test [2] becomes reduced. There is clearly a need to effectively identify such damage. A visual inspection is

Author^α : Energypac Engineering Ltd. 10 Dilkusha C/A, Dhaka, Bangladesh. E-mail : asif038@gmail.com
Tel : +880-2-9137316; Fax: +880-6-82251798

Author^Ω : Department of Electrical & Electronic Engineering Bangladesh University of Engineering & Technology, Dhaka, Bangladesh. E-mail : aminulhoque@eee.buet.ac.bd
Tel : +880-2- 9674344; Fax: +880-2-8613046

costly and does not always produce the desired results or conclusion [3]-[5]. During a field inspection, the oil has to be drained and confined space entry rules apply. Often, a complete tear down is required to identify the problem. An alternative method is to implement field-diagnostic techniques that are capable of detecting damage such as Frequency Response Analysis (FRA) [6]-[10].

There are basically two techniques used for FRA measurements on power transformers; Low Voltage Impulse (LVI) based FRA and Sweep Frequency Response Analysis (SFRA) [11]. The two techniques are also termed FRA-I (impulse method) and FRA-S (swept-frequency method) [12]. The common strategy for both methods [13] is that the transformer impedance is measured at several different frequencies. The impedance will vary from one frequency to another due to the internal constitution of the transformer.

II. SFRA THEORY

When a transformer is subjected to FRA testing, the leads are configured in such a manner that four terminals are used. These four terminals can be divided into two unique pairs [14], one pair for the input and the other pair for the output. These terminals can be modeled in a two-terminal pair or a two-port network configuration. Figure 1 illustrates a two-port network where z_{11} , z_{22} , z_{12} and z_{21} are the open-circuit impedance parameters.

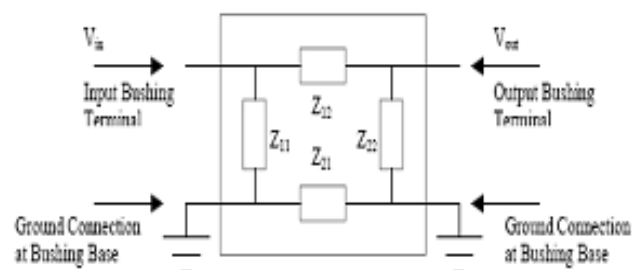

Figure 1 : Two port network

The transfer function of this network [15] is represented in the frequency domain and is denoted by the Fourier variable $H(j\omega)$, where $(j\omega)$ denotes the presence of a frequency dependent function and $\omega = 2\pi f$. The Fourier relationship for the input/output transfer function is given by Equation 1

$$H(j\omega) = \frac{V_{output}(j\omega)}{V_{input}(j\omega)} \quad (1)$$

When a transfer function is reduced to its simplest form, it generates a ratio of two polynomials. The main characteristics, such as half-power and resonance of a transfer function occur at the roots of the polynomials. The roots of the numerator are referred to as "zeros" and the roots of the denominator are "poles" [16]. Zeros produce an increase in gain while poles cause attenuation.

The goal of FRA is to measure the impedance model of the test specimen. When the transfer function $H(j\omega)$ is measured, it does not isolate the true specimen impedance $Z(j\omega)$. The true specimen impedance $Z(j\omega)$ is

the RLC network which is positioned between the instrument leads and it does not include any impedance supplied by the test instrument. Figure 2 illustrates the RLC circuit with shunt resistor.

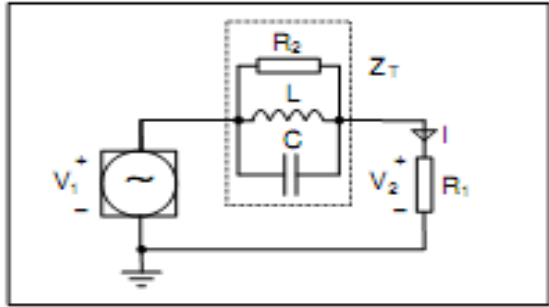

Figure 2: RLC circuit and shunt resistor

From the figure, Voltage division formula gives

$$V_2(j\omega) = V_1(j\omega) \cdot \frac{R_1}{R_1 + \frac{1}{\frac{1}{R_2} + \frac{1}{j\omega L} + j\omega C}}$$

The transfer function is :

$$H(j\omega) = \frac{V_2(j\omega)}{V_1(j\omega)} = \frac{R_1}{R_1 + \frac{1}{\frac{1}{R_2} + \frac{1}{j\omega L} + j\omega C}} = \frac{R_1 \left(\frac{1}{R_2} + \frac{1}{j\omega L} + j\omega C \right)}{R_1 \left(\frac{1}{R_2} + \frac{1}{j\omega L} + j\omega C \right) + 1} \cdot \frac{j\omega L}{j\omega L}$$

$$= \frac{R_1 \left(j\omega \frac{L}{R_2} + 1 - \omega^2 LC \right)}{R_1 \left(j\omega \frac{L}{R_2} + 1 - \omega^2 LC \right) + j\omega L}$$

If R_2 would be removed from the circuit then the term $j\omega \frac{L}{R_2}$ disappears from the expressions above. It is

now easy to see where the resonant frequency must occur : $1 - \omega_r^2 LC = 0 \Rightarrow \omega_r = \frac{1}{\sqrt{LC}}$

At resonant frequency the transfer function is

$$H(j\omega_r) = \frac{R_1 \left(j \frac{L}{R_2 \sqrt{LC}} + 1 - 1 \right)}{R_1 \left(j \frac{L}{R_2 \sqrt{LC}} + 1 - 1 \right) + j \frac{L}{\sqrt{LC}}} = \frac{\frac{R_1}{R_2}}{\frac{R_1}{R_2} + 1} = \frac{R_1}{R_1 + R_2}$$

What is really measured over the shunt resistor R_1 is the current I . So, the transfer function describes the admittance : $Y = \frac{I}{V_1}$. The impedance is thus : $Z = \frac{V_1}{I}$

$$A(\text{dB}) = 20 \log_{10} (H(j\omega))$$

$$A(\Theta) = \tan^{-1} (H(j\omega))$$

The impedance at resonance (including the shunt resistor) is $Z(\omega_r) = \frac{R_1 + R_2}{R_1}$

The Bode Diagram [17] takes advantage of the asymptotic symmetry by using a logarithmic scale for frequency. It is more advantageous to plot $H(s)$ logarithmically over large frequency spans. The logarithmic plot helps to maintain consistent resolution. Plots ranging from 10 Hz to 10 MHz can be displayed as a single plot if they are formatted logarithmically. Fig. 3 shows a typical response for a high voltage star connected winding. The frequency range of interest is between 20 Hz and 2 MHz.

The preferred method of engineers is to use the Bode Diagram. The Bode Diagram plots the magnitude and phase as follows:

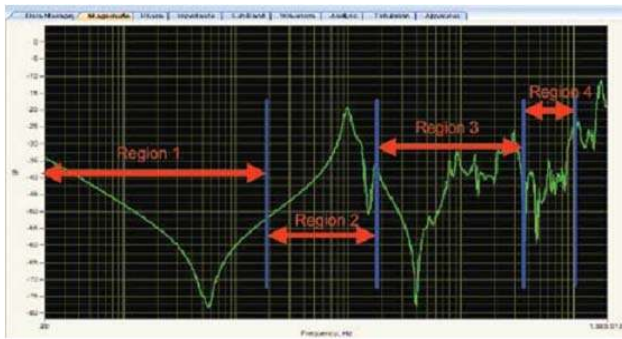

Figure 3 : Frequency Analysis Bands

Experience has shown that different sub-bands are dominated [18] by different internal components of the transformer and are subsequently more sensitive to different types of failures, as summarized in Table 1. Measurements above 2 MHz tend to be dominated by variations in grounding practices for test leads.

Region	Frequency Sub-Band	Component	Failure Sensitivity
1.	< 2 kHz	Main core bulk and winding inductance	Core deformation, open circuits, shorted turns and residual magnetism
2.	2 kHz to 20 kHz	Bulk component and shunt impedances	Bulk winding movement between windings and clamping structure
3.	20 kHz to 400 kHz	Main windings	Deformation within the main or top windings
4.	400 kHz to 1 MHz	Main windings, top windings and internal leads	Movement of the main & top winding, ground impedance variations

Table 1 : Frequency sub-band sensitivity

III. MEASUREMENT PROCEDURE

The FRAX "Generator" (Gen.) generates a sinusoidal voltage at a selected frequency and measures the input voltages, amplitude and phase, on two input channels "Reference" (Ref.) and "Measure" (Meas.). The instrument stores "Amplitude" and "Phase" data for both "Reference" channel and "Measure" channel as well as the ratio "Measure" divided by "Reference". The values can be plotted and exported as Magnitude, Phase, Impedance, Impedance-Phase, Admittance and more. The "Custom models" function makes it possible to calculate almost any parameter based on the measured/stored data. FRAX uses the sine correlation technique [19]. This means that the input voltages are multiplied by a sine and a cosine, and then averaged over an integer multiple of the interval of time. The sine, cosine and the voltage applied have exactly the same frequency. The sine correlation technique is well known and is suitable for Sweep Frequency Response Analysis (SFRA) measurements. Since the signals on the two input channels are treated the same way, the phase resolution between these two channels is very high. The rejection of DC offset and harmonics - referred to as the applied voltage - are in theory infinite. By increasing the integration cycles, the rejection gradually improves.

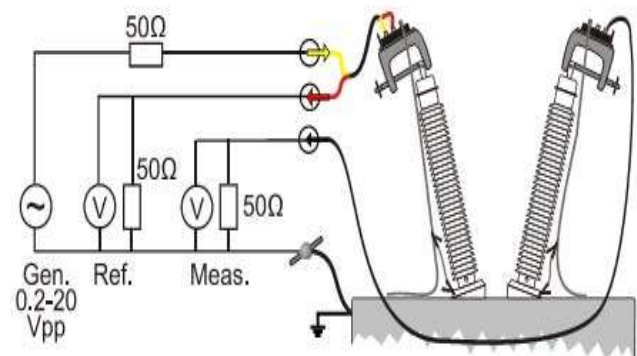

Figure 4 : SFRA Terminal Connection

The IF Bandwidth is commonly used as a parameter defining the bandwidth around the applied signal analyzed. An IF bandwidth of 10% of the active frequency is equivalent to 12 cycles of integration. When considering SFRA measurements, winding measurements realistically consist of three categories. The winding categories are high-voltage, low-voltage, inter winding.

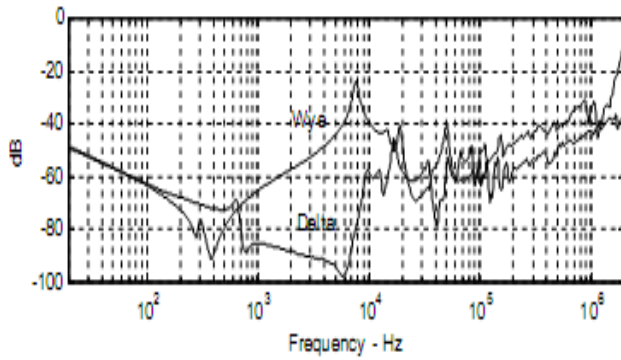

Figure 5 : HV winding response

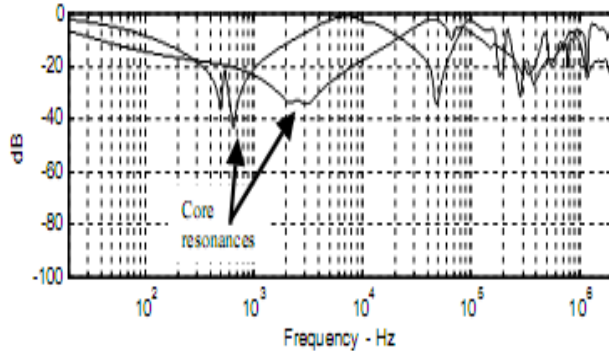

Figure 6 : LV winding response

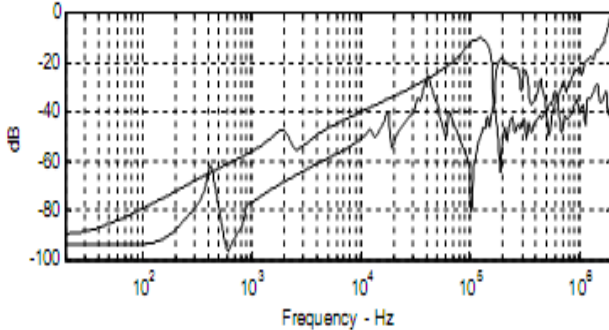

Figure 7 : Inter winding response

Figure 8 presents a high-voltage winding trace, a low-voltage winding trace and an inter-winding trace together from a common test specimen. This illustrates their general relationship.

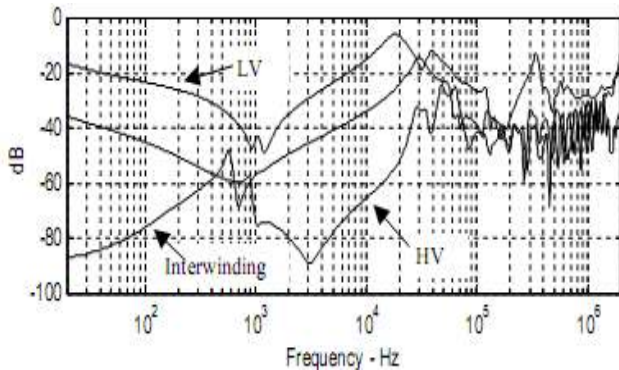

Figure 8 : Complete response

IV. RESPONSE ANALYSIS

For the analysis of a measured response, the response is compared with one of the following:

- An earlier result [20] for the same phase tested with the same tap changer position.
- If no earlier result is available then another phase [18] of the same transformer, tested at the same occasion.
- The same phase, same tap changer position but on a unit believed to be of the same design group and made at the same factory

It is found that Cross Correlation [20] coefficient (CCF) is the most reliable statistical indicator to extract information from comparison method. The CCF is defined as:

$$CCF = \frac{\sum_{i=1}^n (X_i - \bar{X})(Y_i - \bar{Y})}{\sqrt{\sum (X_i - \bar{X})^2 * \sum (Y_i - \bar{Y})^2}}$$

Where X_i and Y_i are the two series (or trace in the case of SFRA) being compared at each individual frequency 'i' and \bar{X} and \bar{Y} are the means.

Equation 1 assumes two real series. In the case of signal processing the math becomes a little more involved, but the end results is still a coefficient between 1 and -1. In SFRA analysis negative CCF are not common but they do occur on occasion. Regardless, negative correlation coefficients are not considered acceptable when trying to look for deviations between traces.

Decision	CCF
Good match	0.95 – 1.0
Close match	0.90 – 0.94
Poor match	≤0.89
No or very poor match	≤0.0

Table 2 : Outcome of CCFs value

Normalizing the results to the individual power spectrums is what allows this resulting waveform to be expressed in a simple single coefficient. Table 2 helps provide a rough estimate of what the CCF means in simple language.

Case	Capacity MVA	HT Voltage kV	LT Voltage kV	Year of manufacture
1	41.67	132	33	1998
2	14	33	11.6	1991

Table 3 : Case study of Fault condition

a) 41.67 MVA, 132/33 kV, 3 ϕ Power Transformer at 132 kV Substation

The results here are from a three phase 25/41.67 MVA, 132/33 kV (vector group Dyn-1) power transformer manufactured by EMCO Transformers Ltd. (Maharastra, India) at 1998 for Bangladesh Power Development Board (BPDB) 132 kV sub-station. The transformer had tripped out of service on protection. No reference factory results were available for this unit. The phase-to-phase HV results didn't show typical variations from standard HV delta winding response. An overall look at the LV winding has showed several shifts between 200 kHz and 2 MHz. This is shown in figure 9 where it is clear that H3-H0 has consistently shifted at higher frequencies with respect to H2-H0 and H1-H0.

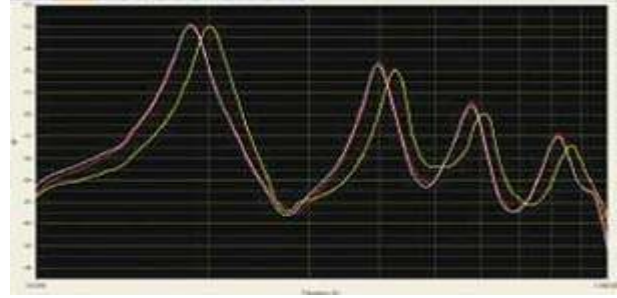

Figure 9 : Close zoom of LV winding response (100 kHz-1 MHz)

This is an indication of axial winding movement at X3 (Blue/C phase) phase. From CCF analysis method results (Table-4), this prediction can be more confirmed.

Frequency Sub-band	CCF results		
	X1-X0, X2-X0	X2-X0, X3-X0	X3-X0, X1-X0
0 – 2 kHz	0.9981	0.9925	0.9954
2 kHz – 20 kHz	0.9943	0.9868	0.9736
20 kHz – 400 kHz	0.9853	0.7263	0.7681
400 kHz – 1 MHz	0.9892	0.9475	0.9424

Table 4 : Test result of LV winding keeping HV open

From the table, it is clearly visible that CCF values of phase A and phase B fulfill "Good Match" criteria in all 4 frequency sub-band regions. CCF values of phase C both with phase A or phase B meet up either "Good Match" or "Close Match" criteria in all bands except region 3. At region 3, both CCF values of phase C (0.7263 and 0.7681) drops down vigorously at "Poor Match" level.

transformer manufactured by Brush Transformers Ltd. (Loughborough, England) at 1991. Due to its age of 20 years, frequency response of this transformer was taken to predict its aging effect. At first, test was carried on HV side keeping LV side open followed by LV side shorted. Corresponding Bode Plot response has been shown in figure 11 and 12.



Figure 10 : Damaged LV (phase-C) coil

Removing the transformer top cover, the active part was brought out and after a through physical inspection, the prediction became true with damage of LV (phase C) coil.

b) 14 MVA, 33/11.6 kV, 3 ϕ Power Transformer at 33 kV Substation

The subjected transformer was running at Dhaka Power Distribution Company (DPDC). It is a 10/14 MVA, 33/11.6 kV (vector group - YNd11) power

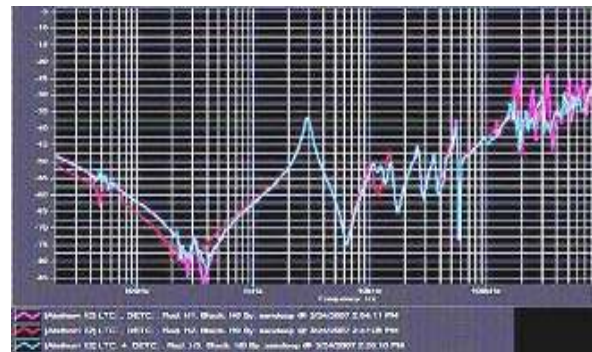

Figure 11 : HV winding response (LV open)



Figure 12 : HV winding response (LV short)

Frequency Sub-band	CCF results		
	X1-X0, X2-X0	X2-X0, X3-X0	X3-X0, X1-X0
0 – 2 kHz	0.7981	0.7825	0.9914
2 kHz – 20 kHz	0.9743	0.9841	0.9736
20 kHz – 400 kHz	0.9523	0.9267	0.9081
400 kHz – 1 MHz	0.8394	0.8975	0.8427

Table 5 : CCF of HV winding keeping LV open

Frequency Sub-band	CCF results		
	X1-X0, X2-X0	X2-X0, X3-X0	X3-X0, X1-X0
0 – 2 kHz	0.9981	0.9925	0.9954
2 kHz – 20 kHz	0.9743	0.9861	0.9786
20 kHz – 400 kHz	0.9354	0.9283	0.9217
400 kHz – 1 MHz	0.8113	0.8671	0.8039

Table 6 : CCF of HV winding keeping LV open

From the CCF result (Table-5), it is easily viewable that the matching is very poor at low frequency region (0-2 kHz). This may be due to core deformation as a result of axial stress because the transformer is running for a long time (20 years). Again, poor matching at higher region (400 kHz-1 MHz) indicates main coil deformation either by radial stress or by axial stress. This deformation is more severe for A phase (Red phase).

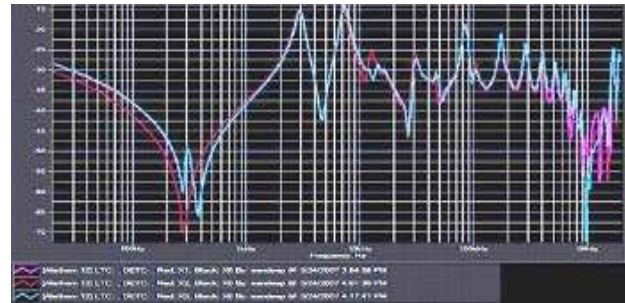

Figure 13 : LV winding response (HV open)

Frequency Sub-band	CCF results		
	X1-X0, X2-X0	X2-X0, X3-X0	X3-X0, X1-X0
0 – 2 kHz	0.8381	0.8325	0.9907
2 kHz – 20 kHz	0.9943	0.9921	0.9936
20 kHz – 400 kHz	0.9825	0.9867	0.9781
400 kHz – 1 MHz	0.8493	0.9275	0.8027

Table 7 : CCF of LV winding keeping HV open

From LV winding response (Figure 13) and corresponding CCF calculation (Table 7), the previous assumption becomes stronger. Poor matching at low frequency region (0-2 kHz) and high frequency region (400 kHz-1 MHz) again spans the prediction of core damage and main winding movement firmly. After replacing the transformer from the system, it was dissected and both the prediction became true.

VI. CONCLUSION

Sweep frequency response analysis method has been applied to a number of three phase and single phase power transformers of different vector groups. This method is also applicable for mechanical deformation and damage diagnosis in distribution

transformers. The parameter Cross Correlation Coefficient (CCF) is found to vary significantly and consistently with mechanical displacements taken place in transformers. So it can be considered as the most effective indicator to predict the internal physical condition of the active part of a transformer.

ACKNOWLEDGEMENT

The authors would like to acknowledge the contributions made by Mr. Rashiduzzaman Bulbul, Assistant Engineer (Testing, Transformer), Energypac Engineering Ltd. for his logistic and data support. They are also grateful to Energypac Engineering Ltd. for frequent high voltage instruments using facility.

REFERENCES REFERENCES REFERENCIAS

1. T. McGrail, "Transformer Frequency Response Analysis: An Introduction", Feature Article NETA WORLD, Spring 2005
2. M. Darveniza, D. J.T. Hill, T.T.Le and T.K.Saha, "Investigations into Effective Methods for Assessing the Condition of Insulation in Aged Power transformers", IEEE Trans. Power delivery, Vol 13, pp.1214-1223, 1998.
3. Kuechler, F. Huellmandel, K. Boehm, C. Neumann, N. Koch, K. Loppach, C. Krause and J.-J. Alff, "Condition Assessment of Aged Transformer Bushing Insulations", Paper A2-104, CIGRE, Paris, France, pp. 1-10. 2006.
4. M. de Nigris et. al., "Application of Modern Techniques for the Condition Assessment of Power Transformers", Cigré Session 2004, Paper No.A2-207.
5. Brian Richardson, "Diagnostics and Condition Monitoring of Power Transformers" IEE, ABB Power Transformer Research and Development Ltd, 1997.
6. S. Ryder, "Diagnosing Transformer faults using frequency response analysis: Results from fault simulations". IEEE/PES Summer Meeting, Chicago, 2002, pp.399-404.
7. S. M Islam, "Detection of Shorted Turns and Winding Movements in Large Power Transformers Using Frequency Response Analysis", IEEE Power Society, Winter Meeting, Singapore, 2000, vol.3, pp.2233-2238.
8. J. A. Lapworth and T J Noonan, "Mechanical condition assessment of power transformers using frequency response analysis" Proceedings of the 1995 International client conference, Boston, MA, USA.
9. Larry Coffeen, Jeffrey Britton and Johannes Rickmann, "A New Technique to Detect Winding Displacements in Power Transformers Using Frequency Response Analysis", IEEE PowerTech Conference, June 23-26, Bologna, Italy, 2003.
10. Luwendran Moodley, Brian de Klerk "Sweep Frequency Response Analysis as A Diagnostic tool to Detect Transformer Mechanical Integrity", eThekwini Electricity pp.1-9, 1978
11. S. Tenbohlen, S. A. Ryder, "Making Frequency Response Analysis Measurements: A Comparison of the Swept Frequency and Low Voltage Impulse Methods", XIIIth International Symposium on High Voltage Engineering, Netherlands 2003, Smit (ed), © 2003 Millpress, Rotterdam, ISBN 90-77017-79-8.
12. M. Wang, A. J. Vandermaar, K. D. Srivastava, "Transformer Winding Movement Monitoring in Service—Key Factors Affecting FRA Measurements", IEEE Electrical Insulation Magazine, Vol. 20, No. 5, pp 5-12, 2004.
13. S. Tenbohlen and S. A. Ryder "Making Frequency Response Analysis Measurements, a Comparison of the Swept Frequency and LV Impulse Methods". 13th International Symposium on HV Engineering, Netherlands, 2003.
14. J. Bak-Jensen, B. Bak-Jensen, and S. D. Mikkelsen, "Detection of Faults and Aging Phenomena in Transformers by Transfer Functions", IEEE Transactions on Power Delivery, vol.10, no.1, January 1999.
15. Jin Zhijian, Li Jingtao, Zhu Zishu, "Diagnosis of Transformer Winding Deformation on the Basis of Artificial Neural Network", Proceedings of The 6th International Conference on Properties and Applications of Dielectric Materials The 21-26,2000, Xi'an Jiaotong University, Xi'an, China.
16. Saha, T. K., Prasad, A., Yao, Z. T., "Voltage Response Measurements for the Diagnosis of Insulation Condition in Power Transformer", International Symposium on High Voltage Engineering, Bangalore, India, August 19-25, 2001, Paper 6-8.
17. Dorf, R.C. and Bishop, R.H. (2005). "Modern Control Systems" 10th ed. Dorling Kindersley, New Delhi, 869p.
18. N.D. Cogger, R.V.Webb, "Frequency Response Analysis", Solartron Analytical, Technical Report 10, 1997.
19. Saha, T.K., Purkait, P., "An Attempt to Correlate Time & Frequency Domain Polarisation Measurements for the Insulation Diagnosis of Power Transformer" , Proceedings of the IEEE Power Engineering Society General Meeting, Denver, Colorado, USA , June 6-10 2004.
20. S. Ryder, "Methods for comparing frequency response analysis measurements". IEEE, Int. Symp. Electrical Insulation, Boston, 2002, pp.187-190.



This page is intentionally left blank