

Determination of Passive and Semi-Passive Chip Parameters Required for Synthesis of Interrogation Zone in UHF RFID Systems

P. Jankowski-Mihulowicz¹, M. Weglarski¹

¹Department of Electronic and Communications Systems, Rzeszow University of Technology,
W. Pola 2, 35-959 Rzeszow, Poland
pjanko@prz.edu.pl

Abstract—In this paper, authors disclose the methodology of interrogation zone synthesis that comprehensively covers all aspects connected with determination of RFID device parameters. The effective methods of involved parameter determination for passive and semi-passive UHF RFID chips are presented. The elaborated measuring procedures have been verified experimentally and are discussed in details. The special untypical laboratory stand has been prepared for carrying out the research tasks. Furthermore, the importance of the parameters for the interrogation zone synthesis is described methodically. In addition, the special software tools that allow researchers to effectively conduct investigations on protocol parameter modifications both in new-developed as well as approved standards (e.g. ISO/IEC 18000-6c) have been designed. These facilities can significantly support many theoretical and simulation works that are developed and described in the branch literature and can improve the reliability and efficiency of designed RFID applications.

Index Terms—Chip parameters, interrogation zone, RFID systems, UHF transponder.

I. INTRODUCTION

The Radio Frequency Identification (RFID) technique is increasingly being used in automated processes of object identification [1]. It is especially developed in various areas of people's economic and social activity, e.g. industry, consumer market, science, medicine, logistics and many other fields [2], [3]. Processes of designing applications with RFID equipment are very complicated because there is necessity to consider a multitude of factors affecting the performance of system components. The authors' experience shows that the interrogation zone (IZ) is the most useful parameter on the designing stage. The IZ determines and comprehensively describes possibilities of applying RFID systems in desirable automated processes [1], [4], [5]. It covers the issues of energy and communication activity of all

parts in the system arrangement. On the base of this parameter, it is possible to build a base of knowledge about essential properties (parameters) of RFID equipment: transponders which are used for marking objects, and also the read/write device (RWD) and its antenna (Fig. 1) which is a management centre. The problem of IZ estimation is comparatively easy to solve in stationary single RFID systems (only one transponder can be present in the IZ and be queried by the RWD, and it should not change localization and rotation during communication processes). On the other hand, the description of this parameter is a very complicated task in anti-collision applications (many transponders can be present in the IZ and simultaneously communicate with the RWD), especially when marked objects dynamically change their location [6], [7].

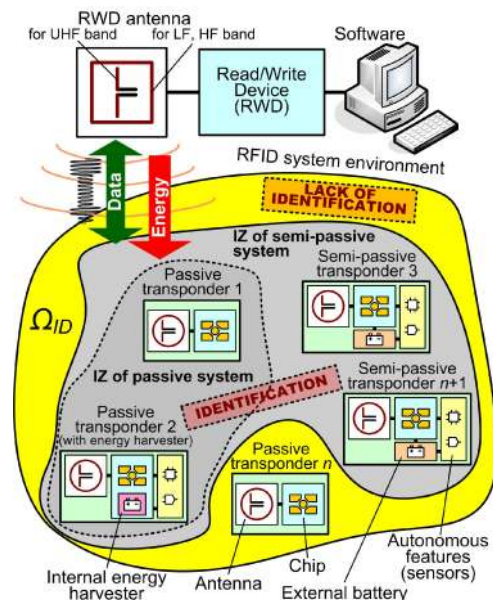

Fig. 1. Generalized block diagram of passive and semi-passive RFID system.

Most applications of the contemporary object identification world are built on the base of single RFID systems. However, these solutions are not sufficient for more sophisticated tasks, especially consisted in recognising multiple objects that dynamically changing their localization. The restricted applicability of this solution is mainly caused

Manuscript received February 19, 2014; accepted September 12, 2014.

This work was supported in part by the Polish National Centre for Research and Development (NCBR) under Grant No. PBS1/A3/3/2012. The work was developed by using the equipment purchased in the Operational Program Development of Eastern Poland 2007-2013 of the Priority Axis I Modern Economics of Activity I.3 Supporting Innovation under Grant No. POPW.01.03.00-18-012/09-00 and the Program of Development of Podkarpace Province of the European Regional Development Fund under Grant No. UDA-RPPK.01.03.00-18-003/10-00.

by possibility of putting only a single transponder in the operating space ID .

In the anti-collision system, the communication process is carried out simultaneously with many RFID transponders (localized in the space ID) by using algorithms of multiple access to the radio channel and special communication protocols, e.g. HITAG1 (in the LF band – typically operating at 125 kHz) ISO/IEC 15693, 18000-3 (in the HF band – typically operating at 13.56 MHz), ISO/IEC 18000-6 (in the UHF band – operating in the range from 860 to 960 MHz depending on the region of the world). The anti-collision identification could find a broad implementation in the dynamic multiple applications but today's knowledge about this brand of the RFID technique is limited and inefficient trial-and-error methods are used in the practice. It gives not efficient solutions (with regards to costs, time consuming in system configuration process, performance parameters) in consequence. It should be emphasized that producers very often do not specify electrical and structural parameters of their products. Because of this, also a calculation of basic parameters describing the IZ is impossible (e.g. the maximal distance – read range – between the transponder and the RWD antenna centre). At the present stage of knowledge, it is the main reason why the practical implementation of anti-collision identification is restrained especially in automated systems operating in dynamic conditions. In order to develop models and then designing tools for these systems, the precise methods for determining transponder parameters have to be found. The synthesis process of any transponder dedicated to a given application is impossible to do without a detailed knowledge about the basic parameters of the chip and the antenna.

The passive RFID transponders are the most popular but despite them the semi-passive solutions (called also active transponders) are used in commercial applications [1]. Semi-passive RFID transponders have built-in an extra source (e.g. lithium battery) which can be exchangeable or not. Since the chip can be supplied with additional energy, the size of interrogation zone can be increased. Moreover, in some designs of typical transponder internal circuits, the extra supply source is used for powering blocks of additional autonomous functions, such as measuring physical quantities (humidity [8]–[10], temperature [9], [11]–[14], light intensity [9], [13], pressure [15], acceleration [16], gas [14], [17], etc.), writing gathered data in a built-in memory, etc. These functions are carried out without the participation of RWD devices. These types of transponders are less popular due to their price and limited durability or periodical necessity of battery replacement. However, it should be noted that the RWD has to be still active to conduct the radio communication process (transmission data in semi-passive RFID systems), because the extra battery system can never be used for activating the transmitting circuit. It means that the transponder antenna does not emit the electromagnetic field as it is in the case of conventional short range devices (SRD) [18]. These characteristics help distinguish the semi-passive RFID transponders from the classical active SRDs.

The problem of sensitivity and input impedance determination in chips of passive RFID transponders

operating in the UHF band is often discussed in the brand literature [19]–[21]. Also, the design of different antenna constructions [22]–[24] and measurements of the transponder parameters [19], [20], [25]–[28] are the matter of scientific research and publications. However, these works only concern the individual problems involved with passive transponders. There is lack of a comprehensive procedure for synthesising RFID applications. Therefore, the authors try to reach a complete methodology of the interrogation zone synthesis that comprehensively covers all aspects connected with determination of transponder parameters. For this aim, the detailed description of chip parameters has been elaborated for both passive and semi-passive transponders. The sensitivity and input impedance of chip has been obtained on the base of the elaborated general model of communication system. All measurements have been conducted in the prepared special research stand that may be adapted to all communication protocol standards of the UHF band. Two commercially available series of RFID chips (passive and passive/semi-passive) have been taken under consideration. Calculations of the RFID system operating range have been presented for selected applications and parameters of used equipment.

II. MODEL OF COMMUNICATION SYSTEM IN UHF BAND

The problem of interrogation zone synthesis can be described in details by the generalized model of communication system (Fig. 2). The model represents electrical circuits and antenna of the read/write device as well as a single transponder (passive or semi-passive). For simplicity, only the single identification process is considered. But, the same algorithm can be multiplied for all arrangements (RWD and additional transponders in IZ) when the anti-collision system is synthesised.

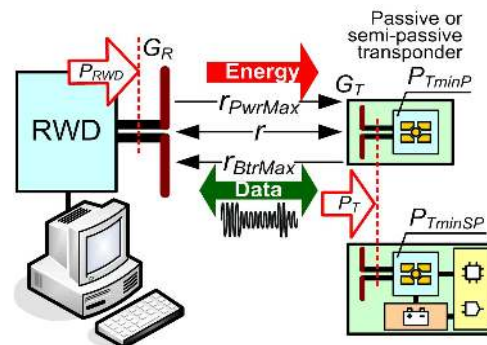

Fig. 2. Passive or semi-passive communication system of RWD – transponder arrangement in UHF band.

The Friis transmission equation can be utilized for determining the interrogation zone of a common radio channel [29]

$$P_T = P_{RWD} \frac{G_R G_T \lambda^2 \tau \chi}{(4\pi r)^2}, \quad (1)$$

where P_{RWD} means the power supplied to terminals of the impedance-matched RWD antenna, G_R – the gain of impedance-matched RWD antenna, P_T – the power received in transponder antenna, G_T – the gain of transponder antenna (the chip and antenna impedance matching is assumed), χ –

the polarization matching factor for given arrangement of radio communication antennas, τ – the coefficient of power transfer from antenna to the chip, λ – the wavelength, r – the distance between antennas.

The interrogation zone boundary, i.e. the maximal distance r_{PwrMax} between axial-symmetrical antennas of a communication system can be determined by transforming (1). The proper conditions for supplying energy to a passive transponder are established in such a defined space. The conditions are characterized by the minimal power P_{Tmin} (chip sensitivity) which is enough for activating internal circuits of the transponder

$$r_{PwrMax} = \frac{\lambda}{4\pi} \sqrt{\frac{P_{RWD} G_R G_T \tau \chi}{P_{Tmin}}}. \quad (2)$$

The transponder sensitivity is dependent on its type (passive or semi-passive) [30], [31] as well as on parameters of radio-communication protocol. There is a relation between the sensitivity of passive transponder chip P_{TminP} and semi-passive P_{TminSP} one

$$P_{TminP} > P_{TminSP}. \quad (3)$$

It yields a larger geometrical space for the interrogation zone of semi-passive systems (Fig. 1). It is possible because of an extra battery source connected to the chip. But it should be emphasized that the relation (3) is valid when the voltage of internal source is in the range of minimal U_{BatMin} and maximal U_{BatMax} values (Fig. 3). Therefore, the sensitivity of semi-passive chip should be specified for the given voltage value of internal supply module U_{Bat} .

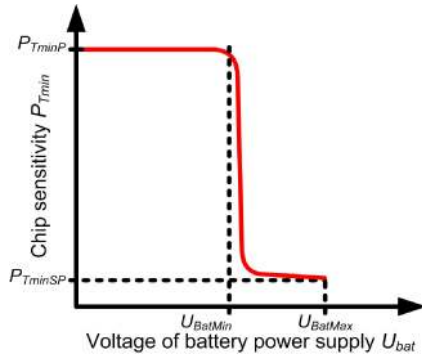

Fig. 3. Generalized curve of sensitivity for passive and semi-passive chip.

The maximal distance r_{PwrMax} has to be compared with a r_{BtrMax} value in the process of interrogation zone synthesis. The r_{BtrMax} means the maximal distance between centres of radio communication system antennas where the proper detection of transmission signal is possible

$$r_{BtrMax} = 4 \sqrt{\frac{\lambda^2}{(4\pi)^3} \frac{P_{RWD} G_R^2 \chi \sigma_T}{P_{Rmin}}}, \quad (4)$$

where σ_T means the effective reflecting area of transponder antenna (Radar Cross Section – RCS), P_{Rmin} – minimal power at the RWD input for signal wave reflected off the transponder.

The signal is transmitted by backscatter communication in the direction from transponder to the read/write device. The process of data exchange can be carried out successfully provided only that the power in antenna circuits of both RWD and transponder reaches the necessary level. The energy gathered by the transponder in a point (x, y, z) has to be enough for supplying the chip with a power P_T greater than the minimal value P_{Tmin} . And also the energy of a signal wave reflected back to the RWD antenna has to be sufficient to give a power P_R greater than the P_{Rmin} value:

$$\begin{cases} \frac{P_T(x, y, z)}{P_{Tmin}} \geq 1, \\ \frac{P_R(x, y, z)}{P_{Rmin}} \geq 1. \end{cases} \quad (5)$$

The equations (1)–(5) can be used to determine the interrogation zone in passive or semi-passive RFID systems of the UHF band. It should be borne in mind, however, that many of the listed parameters depend on electrical and geometrical arrangements of RWD and transponder antennas. This is particularly important in dynamic and anti-collision RFID systems which are dedicated to automated processes of object identification. For example, despite the antenna polar diagrams of $G(\theta)$ and $G(\phi)$, the three-dimensional antenna radiation pattern $G(\theta, \phi)$ has to be taken into consideration when orientation of labelled object is changed in all directions. Moreover, the chip sensitivity (e.i. minimal power P_{Tmin}) is the most important in the IZ synthesis process. It describes supply conditions of the transponder [32]. On the base of this parameter, the chip impedance placed at interrogation zone boundary, the construction of transponder antenna and the shape of interrogation zone for a given implementation of RFID system are worked out.

III. RFID CHIP SENSITIVITY AND IMPEDANCE DETERMINATION

The impedance of transmitters or receivers in conventional radio systems is fixed (e.g. 50, 75 Ω) and matched to the antenna at a given frequency. Another situation is in passive and semi-passive RFID systems. The chip impedance Z_{TC} varies while transponder is working. The impedance matching of chip and antenna Z_{TA} is characterized by the power transfer coefficient τ (Fig. 4).

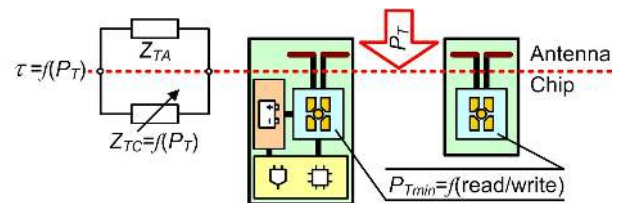

Fig. 4. Electrical equivalent diagram of antenna connected to passive or semi-passive chip.

The gain G_T in (1) and (2) has to be determined at full impedance matching of antenna and chip ($Z_{TA} = Z_{TC}^*$, $\tau = 1$) in order to carry out the interrogation zone synthesis. Thus the power transfer coefficient is described by formula

$$\tau = \frac{4 \operatorname{Re}(Z_{TA}) \operatorname{Re}(Z_{TC})}{(\operatorname{Re}(Z_{TA} + Z_{TC}))^2 + (\operatorname{Im}(Z_{TA} + Z_{TC}))^2}. \quad (6)$$

In practice, the antenna impedance Z_{TA} is constant at a given frequency but the chip impedance varies Z_{TC} while the transponder is working (Fig. 4). This characteristic is crucial in the interrogation zone synthesis but producers of RFID components do not specify it.

The value of impedance Z_{TC} is depended on a transponder localization and orientation according to the RWD antenna. It is because this parameter varies with the power P_T which is transferred from the antenna to the chip [33]. The power level changes are caused by the rectifier and voltage regulator that are main parts of the transponder RF front end [35], [36]. Moreover, operating modes (e.g. reading or writing operation realized on internal memory of chip) also affect the chip impedance, because they can be activated at different power levels ($P_{TminWrite} > P_{TminRead}$). Furthermore, parameters of communication protocols, e.g. ISO/IEC 18000-6c compatible with *Electronic Product Code* requirements, have an effect on the Z_{TC} [37]. Unfortunately, the variable chip impedance has significant influence on measurements of the minimal power P_{Tmin} what makes a measuring task very difficult. The special laboratory stand has been prepared in order to cope with this problem. Two methods of the chip sensitivity determination have been integrated in the research procedure (Fig. 5).

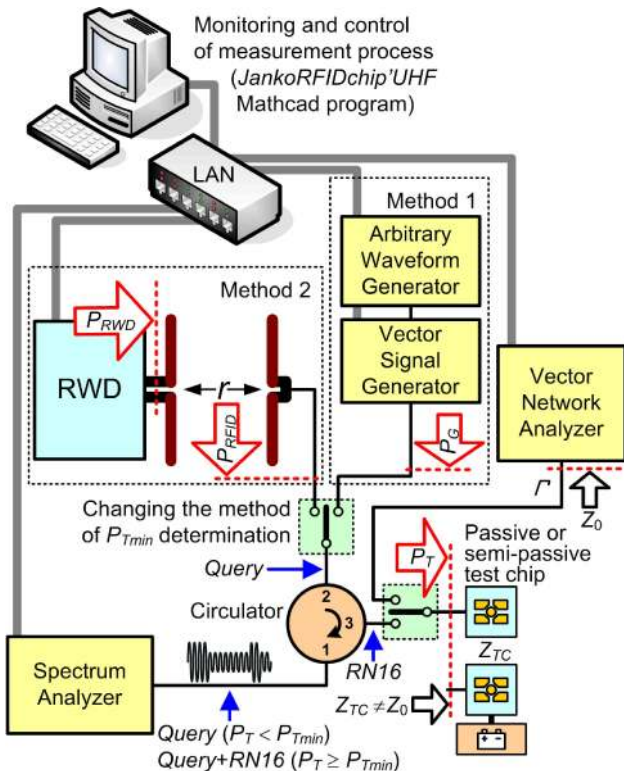

Fig. 5. Block diagram of test stand.

The essence of both methods is to determine the minimum power P_{min} at the moment when 16 b *Random or Pseudo-Random Number (RN16)* is identified as a respond from the transponder. The number is generated as an answer to a *Query* command according to communication protocols [37] when the condition of $P_T \geq P_{Tmin}$ is met. The power P_{Tmin} is

obtained with giving especially consideration to the impedance mismatching of chip (Z_{TC}) and 50 measuring channel (Z_0).

In the first method, the real frame with the *Query* command is generated by measuring equipment. The arbitrary waveform generator (Tektronix AWG5002B) is used as a simulator of modulated signal source and the vector signal generator (R&S SMBV100A) is a source of a carrier signal with adjustable output power.

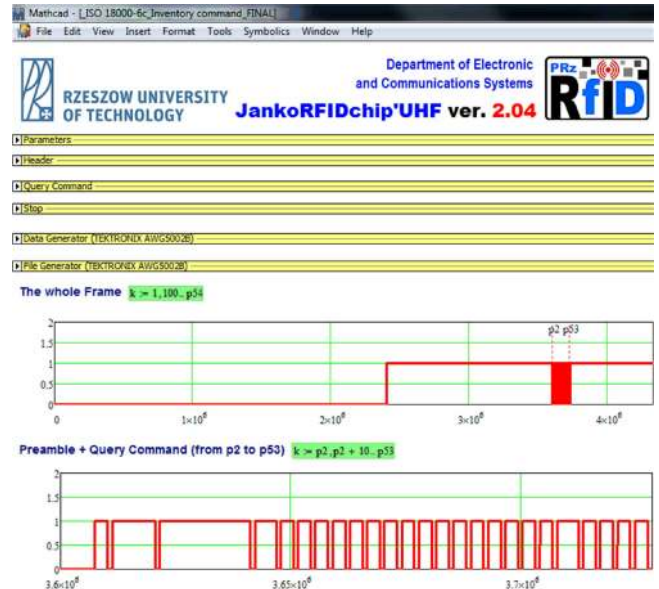

Fig. 6. JankoRFIDchip'UHF program (developed in Mathcad environment).

The pattern of real communication frame is generated by *JankoRFIDchip'UHF* program which has been designed in the Mathcad environment especially for the research task (Fig. 6). The file with the frame prepared according to a specified protocol (Fig. 7) is written to the arbitrary waveform generator by LAN interface.

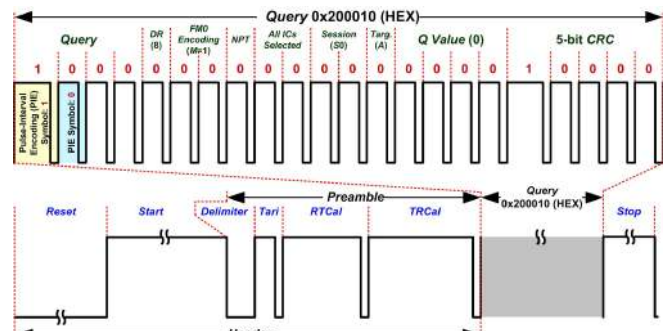

Fig. 7. Frame structure of simulated *Query* command.

The pattern signal is integrated with the carrier in the vector generator. The power P_G (Fig. 5) of output signal with modulated amplitude can be adjusted to a desired level. Generally, the power is transferred with non-modulated carrier, e.g. during *Start* or *Stop* sequences. The frame is sent periodically – it begins with the *Reset* sequence of turning off and resetting internal circuits and finishes with the *Stop* sequence of sending back transponder answer and shutting-down internal blocks. The transmission parameters are synchronized during the header sequence [37].

In the second method (Fig. 5), the long-range read/write

device ID ISC.LRU2000 with ID ISC.ANTU250/250 antenna is utilized instead of expensive research apparatus. The main advantage of this device is the possibility to set up communication protocol parameter according to investigators' tasks. Also, the level of output power P_{RWD} can be adjusted in the development software (ISOStart 2011 v. 8.03.02, Feig Company). In this laboratory stand, the power P_{RFID} transferred in a tested RFID application can be also adjusted in the intrinsic way by changing the distance r between antennas of real equipment.

Comparing both methods, one should notice that the universal and versatile but very expensive generators are used in the first procedure. Thanks to the elaborated special software, the initial process of protocol pattern preparation is very easy and allows designers to control all communication parameters. So, this method can be utilized to conduct all kind of typical and untypical measurement tasks, even including investigations connected with a synthesis of analytical model. Also, the potential environmental disturbances have limited influence on obtained results. The second method is more time consuming with regards to the measurement process configuration. Its versatility is restricted by commercial software tools and it is affected by radio interferences. The main advantage consists in comparatively negligible costs of the laboratory stand.

The command *Query* which is sent in the both procedures is transmitted to the chip by using the ferrite circulator (Alcatel Ferrocom 9C34-31). Since $Z_{TC} \neq Z_0$, the transferred data can be decoded by using the spectrum analyser (Tektronix RSA 3408B) according to requirements of [37]. The analyser can be also utilized to measure the minimal power P_{min} but losses of measuring channel on the way between the analyser input and chip gate have to be taken into account. The sensitivity of tested chip is determined by the relationship

$$P_{Tmin} = P_{min} (1 - |\Gamma|^2), \quad (7)$$

where Γ means the reflection coefficient which is measured by the vector network analyser (VNA – Agilent PNA-X N5242A) at using the flexible cable set (85131F) and electronic calibration module (N4690). The reflection coefficient is specified at the previously determined value of power P_{min} . Prior to the measuring procedure, the VNA input has to be calibrated with the impedance $Z_0 = 50 \Omega$. Also the reference plane has to be moved to the junction of chip and its antenna – the method of port extension can be used [38], [39]. The testing stand and all time-consuming measuring procedures can be controlled remotely by the LAN network on the base of TCP/IP protocol.

IV. RFID CHIP SENSITIVITY AND IMPEDANCE MEASUREMENTS

The experimental research has been carried out in the laboratory of RFID technique at Department of Electronic and Communications Systems at Rzeszów University of Technology (ZSEiT PRz) (Fig. 8).

Two groups of five chips are tested: type 1 – passive –

NXP SL3S1001FFT [40] in TSSOP8 package and type 2 – passive/semi-passive – AMS (IDS previously) SL900A [41] in QFN16 package (Fig. 9). Each passive chip of type 1 has to be precisely soldered straight to SMA connector pins. Since the chips of type 2 can work as passive (powered by electromagnetic field generated by the RWD antenna) or semi-passive (the internal power supply is supported by a built-in battery), the special PCB board is prepared for setting proper modes. The battery voltage U_{bat} is simulated by the power supply unit (Agilent E3631A).

The chip impedance and reflection coefficient is measured in the junction of chip and antenna (reference plane in Fig. 9). The process of sensitivity measurement is performed when the *RN16* response to the *Query* command (Fig. 8(b)) is identified. It is executed for following parameters (Fig. 7): *Delimiter* = 12.5 μ s, *Tari* = Symbol „0” = 6.25 μ s, Symbol „1” = 1.5 \cdot *Tari*, *RTCal* = 2.75 \cdot *Tari*, *TRCal* = 2 \cdot *RTCal*, modulation factor = 90 %. The results of sensitivity measurements are collated in Tables I and II. The values are averaged for the tested group of 5 chips.

TABLE I. MEASURING RESULTS OF PASSIVE CHIP SENSITIVITY (TYPE 1).

f_0 or frequency band (MHz)	P_{Tmin} (dBm)	
	Method 1	Method 2
866	-15.0	-14.8
900	-15.0	-15.0
915	-14.5	-14.4
860-960	-14.8	-14.6

TABLE II. MEASURING RESULTS OF PASSIVE/SEMI-PASSIVE CHIP SENSITIVITY (TYPE 2).

f_0 or frequency band (MHz)	P_{Tmin} (dBm) passive mode: $U_{bat} = 0$ V		P_{Tmin} (dBm) semi-passive mode: $U_{bat} = 1.5$ V	
	Method 1	Method 2	Method 1	Method 2
	866	-13.1	-13.1	-14.8
900	-13.7	-13.6	-15.2	-15.1
915	-13.4	-13.4	-14.9	-15.0
860-960	-13.2	-13.1	-14.9	-14.8

The obtained results are convergent for methods presented in Fig. 5. The measured P_{Tmin} values are very close to the information given in producer's data documentations. However, it should be noted that the information specified by the manufacturers are too perfunctory from the RFID system designer point of view. The chip sensitivity varies with frequency, communication protocol parameters, etc, but these characteristics are very often suppressed in the specifications. Moreover, the conditions of this parameter determination (e.g. what frequency or band was it determined for) are not described by producers. Also, the same problems are valid for the difference between sensitivity values for chip working in passive and semi-passive modes that can be found in datasheets.

The measuring data of P_{Tmin} for the SL900A chip are presented in Table II. The SL900A is tested in both passive and semi-passive modes at $U_{bat} = 1.5$ V (typical voltage of battery power supply). The sensitivity variations vs. U_{bat} voltage are shown in Fig. 10. The minimal value (approx. 1 V) of battery voltage U_{BatMin} is visible in diagrams.

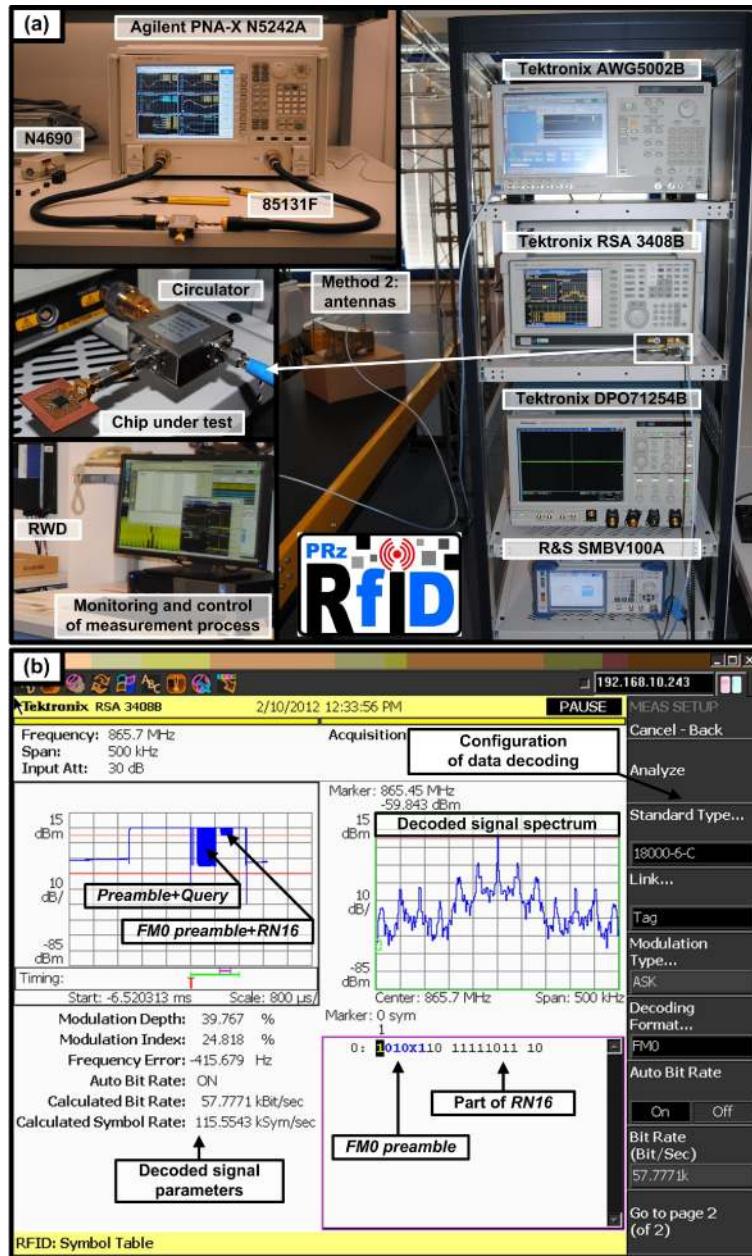

Fig. 8. Equipment of RFID laboratory: a) test stand, b) spectrum analyzer screenshot with decoded data.

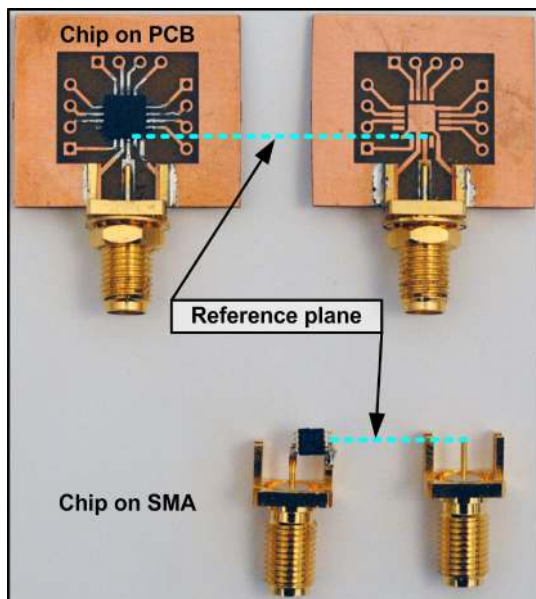

Fig. 9. RFID chips on SMA connector and PCB board.

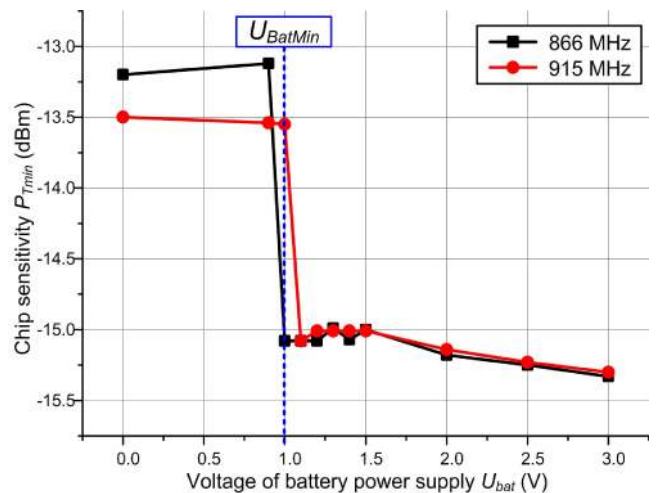

Fig. 10. Measuring results of sensitivity vs. battery voltage for passive/semi-passive chip (type 2).

According to (3), the obtained difference between sensitivity values for the chip of type 2 working in passive

(P_{TminP}) or semi-passive (P_{TminSP}) mode amounts to more than 2 dBm. The above mentioned factors affect the interrogation zone of RFID system. So, it is necessary to determine the sensitivity P_{Tmin} of semi-passive transponders with regards to voltage levels of the auxiliary battery supply unit. It has to be taken into consideration by designers on the stage of RFID equipment preparation.

TABLE III. MEASURING RESULTS OF IMPEDANCE FOR PASSIVE CHIP (TYPE 1).

f_0 or frequency band (MHz)	Z_{rc} ()
866	23.4 - j 486
900	21.3 - j 462
915	22.8 - j 453
860-960	22.0 - j 449

TABLE IV. MEASURING RESULTS OF IMPEDANCE FOR PASSIVE/SEMI-PASSIVE CHIP (TYPE 2).

f_0 or frequency band (MHz)	Z_{rc} ()	
	passive mode $U_{bat} = 0$ V	semi-passive mode $U_{bat} = 1.5$ V
866	14.9 - j 342	14.7 - j 338
900	14.9 - j 319	14.4 - j 316
915	15.3 - j 313	14.9 - j 309
860-960	14.5 - j 316	14.0 - j 314

Only, the correct chip sensitivity determination gives possibility to measure the chip impedance by the means of VNA. The results of impedance measurement are listed in Table III and IV. The values are obtained at the sensitivity P_{Tmin} which is carried out by the method 1 (Table I and II). Variations of real and imaginary parts of the complex impedance Z_{rc} versus the power P_T are presented in Fig. 11 and Fig. 12. The diagrams for the passive and passive/semi-passive chip are shown in the chart.

Significant differences in the impedance can be observed for the power P_T above the points of -10 dBm (chip of type 1) and -6 dBm (chip of type 2). It is caused by the internal stabilizer of chip which has to adjust voltage in the input circuits. This effect does not have significant impact on the measuring procedure of interrogation zone range. It is because the amount of energy which is harvested from electromagnetic field generated by the RWD antenna is enough for proper operation of chip.

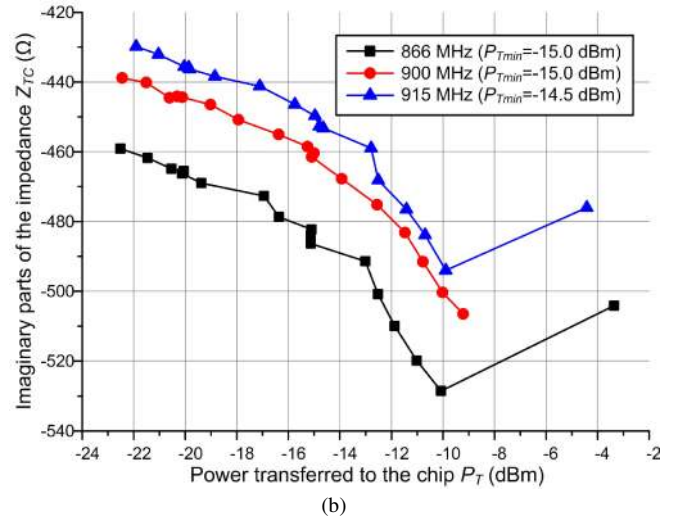
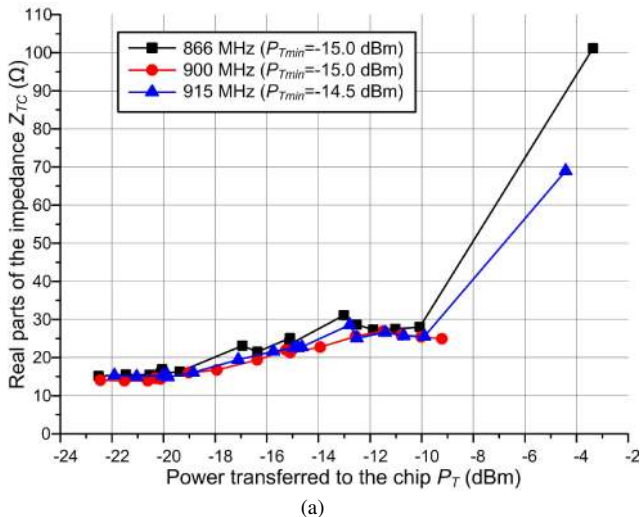

Fig. 11. Measurement results of impedance for passive chip (type 1).

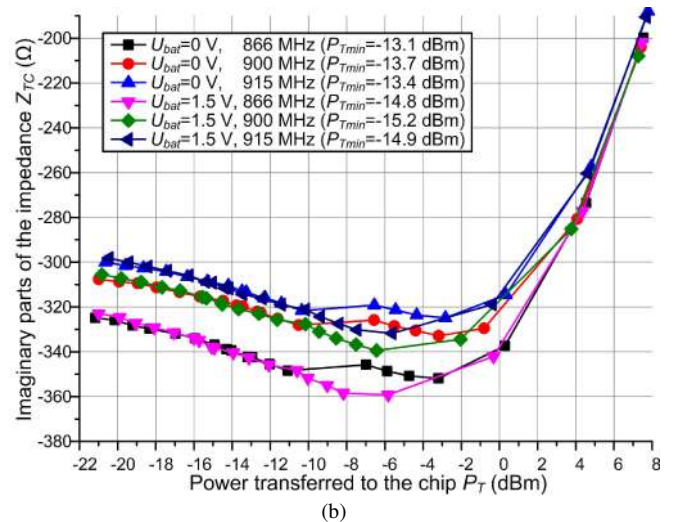
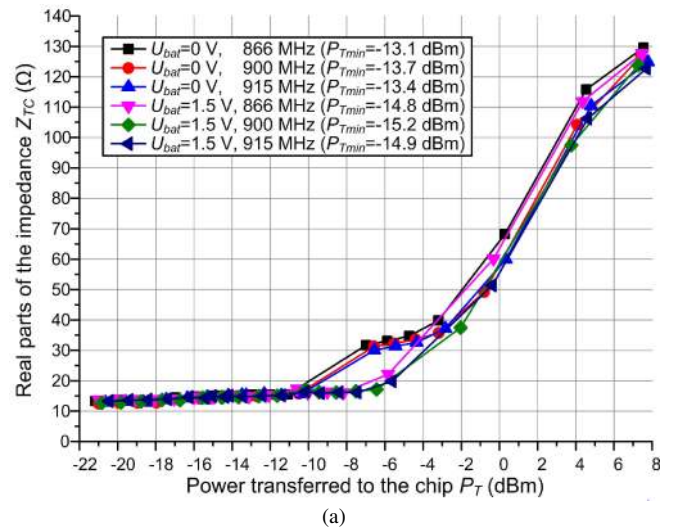

Fig. 12. Measurement results of impedance for passive/semi-passive chip (type 2).

However, it should be noted that the impedance value at the power P_{Tmin} for the chip of type 2 is independent of the supplementary battery source. This fact has essential practical meaning because it allows designers to construct only one type of transponder antenna for the both operating modes (passive and semi-passive).

V. INTERROGATION ZONE CALCULATION – READ RANGE

The read range, i.e. maximal distance between centres of the transponder and RWD antenna, is the basic parameter which describes the interrogation zone. Its determination is indispensable for the processes of RFID technique implementations in the automatic object identification. It is especially important for long range systems which work according to requirements of electronic product code in the UHF band (protocol ISO 18000-6c, RWD compatibility: a) European version of ETSI EN 302 208 – 2 W ERP, frequency band 865,6-867,6 MHz, or b) American version of FCC Part 15.247 – 1 W of transmitter output power with maximal gain of 6 dBi – 4 W EIRP, frequency band 902 MHz–928 MHz).

Power supply conditions described by (2) and (5) have to be taken into consideration in the process of interrogation zone and its parameters determination. It is because of the typical level of long range RWD circuit sensitivity in the UHF band ($P_{Rmin} = -100 \div -70$ dBm [42], [43]). The results of numerical calculations for the r_{PwrMax} distance which describes the read range and boundary of IZ are presented in Table V and VI. They are obtained on the base of (2).

TABLE V. READ RANGE CALCULATION FOR PASSIVE CHIP (TYPE 1).

f_0 (MHz)	r_{PwrMax} (m)
866	5.08
900	4.89
915	4.54

TABLE VI. READ RANGE CALCULATION FOR PASSIVE/SEMI-PASSIVE CHIP (TYPE 2).

f_0 (MHz)	r_{PwrMax} (m) passive mode: $U_{bat} = 0$ V	r_{PwrMax} (m) semi-passive mode: $U_{bat} = 1.5$ V
866	4.08	4.96
900	4.21	5.00
915	4.00	4.75

The following values are assumed in the calculations: the sensitivity of RWD circuits $P_{Rmin} = -80$ dBm; the power of $P_{RWD} = 0.5$ W is provided to terminals of matched RWD antenna; the maximal gain of matched antennas is equal to $G_R = 6$ dBi for RWD and $G_T = 1.3$ dBi ($\chi = -3$ dB, $\tau = 0.8$) for transponder. The assumed values are consistent with parameters of measuring devices which are available in the RFID laboratory of ZSEiT PRZ.

Small variations of the sensitivity which are observed in the obtained results have a noticeable influence on the read range of RFID system (Table V and Table VI for the passive mode). The difference (about 2 dBm) between values of sensitivity for the passive and semi-passive mode in the chip of type 2 causes a change in the transponder read range of tens of centimetres. (Table VI). This significant discrepancy can be vital to select the appropriate RFID equipment for a given implementation. Therefore, the accurate estimation of the basic chip parameters is crucial to the whole process of RFID system designing.

The problem of 3D IZ synthesis and also calculations and experimental verifications for the anti-collision UHF RFID systems are presented in details in [44]. This elaboration can significantly support many theoretical and experimental

works that are developed and described in the branch literature and can improve the reliability and efficiency of designed RFID applications. It is especially important when the time of communication process, the optimal number of transponders, and also type of RFID application (static, dynamic) should be considered in the anti-collision system [45], [46]. In this matter, it should be noted that the prepared software tool *JankoRFIDchip'UHF* will allow in the future to effectively conduct investigations on protocol parameter modifications both in new-developed as well as approved standards (e.g. ISO/IEC 18000-6c).

VI. CONCLUSIONS

The proper operation of RFID system is the most important feature for each end-user. It means that all labelled objects are recognized if they appear in the working space of system. Only the properly realized RFID system design gives the possibility to meet these requirements. To reach this state, designers have to be able to gather the full database with parameters of involved equipment. Unfortunately, manufacturers do not specify all of the information which is necessary in this scope. For this reason, the know-how of interrogation zone and its basic parameters (e.g. read range) estimation is the crucial skill.

According to chip parameters, it should be emphasised that there is not universal ICs (integrated circuits) as well as transponders in the commercial market which can be used in all applications. It is always necessary to design a proper antenna that has to be adjusted to the chip input circuits and the given implementation of RFID system. Despite such a significant influence on usefulness of the systems, the huge deficiencies and inconsistency in parameter specifications can be found in producers' technical documentations. Please notice that incomplete or incorrect values can negatively result in the antenna design and the interrogation zone decreases as a consequence. Further, the RFID system efficiency and reliability will be limited and not gratifying for the user.

REFERENCES

- [1] K. Finkenzerler, *RFID Handbook*. Wiley, 2010. [Online]. Available: <http://dx.doi.org/10.1002/9780470665121>
- [2] D. Brown, *RFID Implementation*. McGraw-Hill, 2007.
- [3] E. Jones, C. Chung, *RFID in Logistics - A Practical Introduction*. CRC, 2008.
- [4] P. Jankowski-Mihulowicz, W. Kalita, "Interrogation zone – a basic application parameter of RFID systems", *Electronics - Constructions, Technologies, Applications*, vol. 8, pp. 67–72, 2010.
- [5] M. Bolic, D. Simplot-Ryl, I. Stojmenovic, *RFID Systems Research Trends and Challenges*. Wiley, 2010.
- [6] P. Jankowski-Mihulowicz, W. Kalita, B. Pawlowicz, "Problem of dynamic change of tags location in anticollision RFID systems", *Microelectron. Rel.*, vol. 48, no. 6, pp. 911–918, 2008. [Online]. Available: <http://dx.doi.org/10.1016/j.microrel.2008.03.006>
- [7] P. Jankowski-Mihulowicz, M. Weglarski, "Determination of 3-dimensional interrogation zone in anticollision RFID systems with inductive coupling by using Monte Carlo method", *Acta Physica Polonica A*, vol. 121, no. 4, pp. 936–940, 2012.
- [8] C. W. Lee, S. J. Lee, M. Kim, Y. Kyung, K. Eom, "Capacitive humidity sensor tag smart refrigerator system using the capacitive to voltage converter (CVC)", *Int. J. Adv. Sci. Technol.*, vol. 36, pp. 15–25, 2011.
- [9] E. Abad, et al., "Fabrication process for a flexible tag microlab", *Proc. SPIE 6589, Smart Sensors, Actuators, and MEMS III*, 2007.
- [10] A. Oprea, et al., "Capacitive humidity sensors on flexible RFID

- labels”, *Sens. Actuators B: Chem.*, vol. 132, pp. 404–410, 2009. [Online]. Available: <http://dx.doi.org/10.1016/j.snb.2007.10.010>
- [11] T. Volk, *et al.*, “Active RFID sensor with integrated file system for logistic applications”, in *Proc. Eur. Workshop Smart Objects: Syst., Technol. and Appl. (RFID Sys Tech)*, 2010, pp. 1–7.
- [12] Shiho Kim, *et al.*, “An EPC Gen 2 compatible passive/semi-active UHF RFID transponder with embedded FeRAM and temperature sensor”, in *Proc. IEEE Asian Solid-State Circuits Conf. ASSCC*, 2007, pp. 135–138.
- [13] D. Cartasegna, *et al.*, “Smart RFID label for monitoring the preservation conditions of food”, *Sens. Microsys.*, vol. 54, pp. 381–385, 2010. [Online]. Available: http://dx.doi.org/10.1007/978-90-481-3606-3_77
- [14] A. Oprea, *et al.*, “Temperature, humidity and gas sensors integrated on plastic foil for low power applications”, *Sens. Actuators B: Chem.*, vol. 140, pp. 227–232, 2009. [Online]. Available: <http://dx.doi.org/10.1016/j.snb.2009.04.019>
- [15] L. Yang, A. Rida, T. Wu, S. Basat, M. M. Tentzeris, “Integration of sensors and inkjet-printed RFID tags on paper-based substrates for UHF cognitive intelligence applications”, in *Proc. IEEE-APS Symp.*, Honolulu, 2007, pp. 1193–1196.
- [16] A. Tani, M. Ugaji, Y. Yamabe, “A building structural-performance monitoring system using RFID tag with sensors”, in *Proc. Int. Conf. Comput. in Civil and Build. Eng.*, 2010, p. 441.
- [17] E. Abad, *et al.*, “Flexible tag microlab development: gas sensors integration in RFID flexible tags for food logistic”, *Sens. Actuators B: Chem.*, vol. 127, no. 1, pp. 2–7, 2007. [Online]. Available: <http://dx.doi.org/10.1016/j.snb.2007.07.007>
- [18] CEPT/ECC, *ERC recommendation 70-03 relating to the use of short range devices (SRD)*, 2012.
- [19] P. V. Nikitin, K. V. S. Rao, R. Martinez, S. F. Lam, “Sensitivity and impedance measurements of UHF RFID chips”, *IEEE Trans. Microw. Theory Tech.*, vol. 57, no. 5, pp. 1297–1302, 2009. [Online]. Available: <http://dx.doi.org/10.1109/TMTT.2009.2017297>
- [20] J. Grosinger, C. Mecklenbrauker, A. L. Scholtz, “UHF RFID transponder chip and antenna impedance measurements”, in *Proc. Third Inter. EURASIP Workshop RFID Technol.*, 2010, pp. 43–46.
- [21] R. Kronberger, A. Geissler, B. Friedmann, “New methods to determine the impedance of UHF RFID chips”, in *IEEE Inter. Conf. RFID*, 2010, pp. 260–265.
- [22] G. Marrocco, “The art of UHF RFID antenna design: impedance matching and size-reduction techniques”, *IEEE Antennas and Propag. Mag.*, vol. 50, no. 1, pp. 66–79, 2008. [Online]. Available: <http://dx.doi.org/10.1109/MAP.2008.4494504>
- [23] A. H. Rida, *et al.*, “Design, development and integration of novel antennas for miniaturized UHF RFID tags”, *IEEE Trans. Antennas Propag.*, vol. 57, no. 11, pp. 3450–3457, 2009. [Online]. Available: <http://dx.doi.org/10.1109/TAP.2009.2027347>
- [24] H. Makimura, Y. Watanabe, K. Watanabe, H. Igarashi, “Evolutional design of small antennas for passive UHF-band RFID”, *IEEE Trans. Magn.*, vol. 47, no. 5, pp. 1510–1513, 2011. [Online]. Available: <http://dx.doi.org/10.1109/TMAG.2010.2089607>
- [25] T. Bjorninen, *et al.*, “Wireless measurement of RFID IC impedance”, *IEEE Trans. Instrum. Meas.*, vol. 60, no. 9, pp. 3194–3206, 2011. [Online]. Available: <http://dx.doi.org/10.1109/TIM.2011.2123190>
- [26] Kai Xu, *et al.*, “Design verification and measurement techniques for UHF RFID tag IC”, in *Proc. 7th Int. Conf. Wireless Commun., Netw. and Mobile Comput.*, 2011, pp. 1–5.
- [27] J. H. Rudander, Ikram-e-Khuda, P. S. Kildal, C. Orlenius, “Measurements of RFID tag sensitivity in reverberation chamber”, *IEEE Antennas Wireless Propag. Lett.*, vol. 10, pp. 1345–1348, 2011. [Online]. Available: <http://dx.doi.org/10.1109/LAWP.2011.2177512>
- [28] L. Catarinucci, D. De Donno, R. Colella, F. Ricciato, L. Tarricone, “A cost-effective SDR platform for performance characterization of RFID tags”, *IEEE Trans. Instrum. Meas.*, vol. 61, no. 4, pp. 903–911, 2012. [Online]. Available: <http://dx.doi.org/10.1109/TIM.2011.2174899>
- [29] C. Balanis, *Antenna Theory*, Wiley, 2005, pp. 94–96.
- [30] N. Tran, J. W. Lee, “Simple high-sensitivity voltage multiplier for UHF-band semi-passive radio frequency identification tags using a standard CMOS process”, *IET Microw., Antennas & Propag.*, vol. 4, no. 11, pp. 1974–1979, 2010. [Online]. Available: <http://dx.doi.org/10.1049/iet-map.2009.0288>
- [31] Wenyi Che, *et al.*, “A semi-passive UHF RFID tag with on-chip temperature sensor”, in *Proc. IEEE Custom Integr. Circuits Conf., CICC*, 2010, pp. 1–4.
- [32] J. D. Griffin, G. D. Durgin, “Complete link budgets for backscatter-radio and RFID systems”, *IEEE Antennas and Propag. Mag.*, vol. 51, no. 2, pp. 11–25, 2009. [Online]. Available: <http://dx.doi.org/10.1109/MAP.2009.5162013>
- [33] G. de Vita, G. Iannaccone, “Design criteria for the RF section of UHF and microwave passive RFID transponders”, *IEEE Trans. Microw. Theory Tech.*, vol. 53, no. 9, pp. 2978–2990, 2005. [Online]. Available: <http://dx.doi.org/10.1109/TMTT.2005.854229>
- [34] Yuan Yao, Jie Wu, Yin Shi, Fa Foster Dai, “A Fully integrated 900-MHz passive RFID transponder front end with novel zero-threshold RF–DC rectifier”, *IEEE Trans. Ind. Electron.*, vol. 56, no. 7, pp. 2317–2325, 2009. [Online]. Available: <http://dx.doi.org/10.1109/TIE.2008.2010180>
- [35] P. Wei, *et al.*, “High-efficiency differential RF front-end for a Gen2 RFID tag”, *IEEE Trans. Circuits Syst.*, vol. 58, no. 4, pp. 189–194, 2011. [Online]. Available: <http://dx.doi.org/10.1109/TCSII.2011.2124530>
- [36] P. Jankowski-Mihulowicz, W. Kalita, “Efficiency of tag antenna unit in anticollision radio frequency identification systems with inductive coupling”, *Acta Electrotechnica et Informatica*, vol. 9, no. 2, pp. 3–7, 2009.
- [37] EPCglobal, “EPCglobal Inc. – Class-1 Generation-2 UHF RFID Protocol for Communications at 860-960 MHz”, Ver. 2.0, 2013.
- [38] Agilent, “In-Fixture Measurements Using Vector Network Analyzers”, AN 1287-9, 5968-5329E, Agilent Technologies, 2006.
- [39] A. Rumiantsev, N. Ridler, “VNA calibration”, *IEEE Microw. Mag.*, vol. 9, no. 3, pp. 86–99, 2008. [Online]. Available: <http://dx.doi.org/10.1109/MMM.2008.919925>
- [40] NXP Semiconductors, “SL3 ICS 10, UCODE EPC G2”, Product data sheet, Rev. 3.0, No. 109930, 2006.
- [41] IDS Microchip AG, “SL900A Single-Chip EPC Data Logger with Sensor”, Product Flyer, 2010.
- [42] I. Kipnis, *et al.*, “A 900MHz UHF RFID reader transceiver IC”, in *Proc. IEEE Internat. Solid-State Circuits Conf.*, 2007, pp. 214–215.
- [43] I. Kwon, *et al.*, “A single-chip CMOS transceiver for UHF mobile RFID reader”, *IEEE J. Solid-State Circuits*, vol. 43, no. 3, pp. 729–738, 2008. [Online]. Available: <http://dx.doi.org/10.1109/JSSC.2007.914302>
- [44] P. Jankowski-Mihulowicz, M. Weglarski, “Interrogation zone determination for RFID systems working in UHF band”, *PAK - Measurement Automation and Monitoring*, vol. 57, no. 12, pp. 1469–1472, 2011.
- [45] H. Vogt, “Efficient object identification with passive RFID Tags”, *Pervasive Computing, Lecture Notes in Computer Science*, vol. 2414, pp. 98–113, 2002.
- [46] M. Gotfryd, B. Pawlowicz, “Modeling of a dynamic RFID system”, in *Proc. 18th IEEE ISCC*, Split, 2013, pp. 747–752.