

Проведено моделювання динамічної навантаженості кузова напіввагона при закріпленні його в'язкою стязкою відносно палуби залізничного порома. Актуальність дослідження викликана тим, що рух вагонів морем на залізничних поромах супроводжується дією на несучі конструкції кузовів значних величин навантажень. Чисельні значення цих навантажень значно перевищують ті, що діють на вагони при експлуатації відносно магістральних колій. Крім того, існуюча схема не забезпечує надійності закріплення кузова та зумовлює пошкодження його конструкційних елементів. Це викликає необхідність здійснення внепланових ремонтів вагонів при перевезенні на залізничних поромах. Тому запропоновано удосконалити схему закріплення вагона відносно палуби залізничного порому. Для пом'якшення дії навантажень від ланцюгових стязок на кузов вагона пропонується здійснювати не жорсткий зв'язок між ними, а в'язкий, посередництвом встановлення спеціального пристрою – демпфера між кузовом та палубою.

З метою моделювання динамічної навантаженості кузова вагона з урахуванням запропонованих технічних рішень побудовано математичну модель та визначено величини прискорень, які діють на кузов. Модель враховує переміщення залізничного порому з вагонами при бічній хитавиці, як одного з основних видів коливань судна. Встановлено, що при запропонованій схемі закріплення кузова вагона відносно палуби є можливим знизити величину його динамічної навантаженості на 30 %.

Визначення динамічної навантаженості кузова вагона також проведено шляхом комп'ютерного моделювання в середовищі програмного забезпечення CosmosWorks. Визначено чисельні значення та поля дислокації прискорень кузова напіввагона. Верифікація розроблених моделей проведена за F-критерієм. Проведені дослідження сприятимуть забезпеченню збереження несучих конструкцій кузовів вагонів при перевезенні на залізничних поромах, а також підвищенню ефективності їх експлуатації через міжнародні транспортні коридори

Ключові слова: несуча конструкція, динамічна навантаженість, залізнично-водний транспорт, залізнично-поромні перевезення, моделювання динаміки, метрологічні випробування

UDC 629.463.004.4:656.211.7

DOI: 10.15587/1729-4061.2019.160456

DETERMINING THE DYNAMIC LOADING ON A SEMI-WAGON WHEN FIXING IT WITH A VISCOUS COUPLING TO A FERRY DECK

O. Fomin

Doctor of Technical Sciences, Associate Professor
Department of Cars and Carriage Facilities*
E-mail: fomin1985@ukr.net

A. Lovska

PhD, Associate Professor
Department of Wagons
Ukrainian State University of Railway Transport
Feierbakh sq., 7, Kharkiv, Ukraine, 61050
E-mail: alyonaLovskaya.vagons@gmail.com

I. Kulbovskiy

PhD, Associate Professor
Department of Building Structures and Facilities*
E-mail: kulbovskij@ukr.net

H. Holub

PhD, Associate Professor
Department of Automation and
Computer-Integrated Technologies of Transport*
E-mail: golub.galina@ukr.net

I. Kozarchuk

PhD
Department of Transport Construction
and Property Management**
E-mail: igor.a.kozarchuk@gmail.com

V. Kharuta

PhD
Department of Transport Law and Logistics**
E-mail: kharuta_vitaliy@ukr.net

*State University of Infrastructure and Technology
Kyrylivska str., 9, Kyiv, Ukraine, 04071

**National Transport University
Mykhaila Omelianovycha-Pavlenka str., 1,
Kyiv, Ukraine, 01010

1. Introduction

The development and strengthening of cross-border links between European countries necessitate reforms in the transportation sector. One of the most promising solutions in this area was the creation of intermodal

transportation systems. Those countries that have access to international channels through marine waters are developing railroad-ferry transportation. A special feature of such transportation is the possibility to transport wagons by sea aboard specially equipped vessels – railroad ferries.

To ensure the stability of wagons relative to decks, they are fixed by a complex of multi-turn means. These include chain ties with turnbuckles (eight pieces per wagon), stop-jacks (four pieces per wagon), brake shoes that are mounted under the surface of rolling wheels. To keep wagons from longitudinal displacement, the extreme wagons in couples are connected to buffer stops [1, 2].

It is important to note that the design of the bodywork of wagons does not imply special elements that are intended to fix them relative to the decks of railroad ferries. Thus, when transporting wagons by sea, the interaction between bodies and the means of fastening is enabled via any components of the structure.

In addition, a typical scheme of fixing the body of a wagon relative to the deck does not imply a possibility to mitigate the dynamic loads acting on it via fastening. A chain coupling transmits the load to the body taking into consideration the initial effort of pulling (50–60 kN), as well as the effort that occurs during oscillations of a railroad ferry.

Such a pattern causes damage to the bearing structures of wagons' bodies when they are transported by sea and requires unplanned kinds of repair.

The loss of stability by a wagon body car relative to the deck may lead to the destruction of a railroad ferry. Thus, in 2002, as a result of the loss of stability by wagons-tanks relative to the deck, the railroad ferry «Merkury-2» sank in the Caspian Sea. There were 16 wagons-tanks with oil products aboard the ship, one carriage with commercial cargo, 8 passengers, and 42 crewmen. The wagons-tanks that broke away from fasteners because of a wave, rolled towards the inclination and contributed to the sinking of the vessel [3].

Thus, it is important to improve the scheme of fixing wagons to the deck of railroad ferries when they are transported by sea. One of the solutions to this task is to create new devices for fastening bodies relative to decks.

2. Literature review and problem statement

The simulation of dynamic loading on freight wagon bodies, whose bearing elements are made from round pipes, was performed in [4]. The authors determined the accelerations acting on wagons at shunting interaction using mathematical modeling and computer simulation. They proved the feasibility of the proposed technical solutions to improve wagons. However, when designing such structures of wagons, they took into consideration the loads that could act in operation along railroad tracks. That is, the loading on bearing structures of bodies when they are transported by railroad ferries was not examined in that work.

The authors of [5] determined the dynamic loads that act on the bodies of freight wagons when they are transported by a railroad ferry. The calculations were carried out using computer simulation of the main types of railroad ferry oscillations. They substantiated the necessity to take into consideration the loads acting on wagons when they are transported by railroad ferries at the design stage under conditions of car building facilities. The authors did not pay attention to issues concerning improvement of the scheme of interaction between wagons' bodies aimed to ensure the reliability of their fastening to the deck of a railroad ferry.

The strength and fatigue of a welded bearing structure of the wagon body were considered in [6]. The authors determined the causes of defects in the structural elements of

a wagon body. To provide for the strength of wagon bodies of the new design, as well as of those that are under repair, they proposed measures for improvement. In this case, reinforcement elements are installed in the zone of interaction between a girder beam and a pivot beam. However, when constructing a model of the strength of a wagon's frame, the authors did not take into consideration the efforts that could act during transportation by a railroad ferry.

An analysis of structural characteristics of the freight cars BCNHL was reported in [7]. The authors identified possible ways to improving the technical and economic indicators for wagons in order to improve the efficiency of their operation. The work failed to pay attention to the need to improve the scheme of interaction between a wagon and the deck of a railroad ferry.

The results of a structural-element analysis of a freight wagon using the method of finite elements are given in [8]. The research was conducted using an example of a semi-wagon of the type «BOXN25», which is in operation at Indian Railroads. The authors calculated strength using a method of finite elements and a modal analysis of the body of a freight wagon. The calculation of critical frequencies of oscillations was performed up to 30 Hz. Dynamic loading and the strength of a wagon when it is transported by a railroad ferry were not investigated in that publication.

Paper [9] reported determining the longitudinal forces arising in a freight train taking into consideration different types of wagon-to-wagon connections. The calculations were performed using the software «Universal mechanism». It was established that the use of an absorbing device of the type Sh-2-T in the automatic coupling device ensures the occurrence of the smallest longitudinal efforts in the train. That work did not address the issue of studying the dynamic loading of a bearing structure of a wagon body when it is transported by a railroad ferry.

The authors of [10] defined the feasibility of using the coupled implementation of a girder beam. The research was conducted theoretically and experimentally using a pellet wagon as an example. The proposed measures would help reduce the cost of making new wagon structures. When performing calculations for the strength of a given wagon, the authors did not consider the loading that could act on it when it is transported by a railroad ferry.

Research and analysis of the stressed-strained state of load-bearing structures in the semi-wagons of domestic production, with the wear characteristic of 1.5 terms of operation, were reported in [11]. When constructing a model of the body strength, the authors took into consideration the actual magnitudes of wear for bearing elements. It was established that the maximum equivalent stresses in this case did not exceed the permissible ones, which makes it possible to draw a conclusion about the possibility of further operation of the wagon. When performing calculations for the strength of a bearing structure of the semi-wagon body, the authors did not account for the loading that could act when it is transported by a railroad ferry.

A study into fatigue strength of the body of a semi-wagon under operational modes at loading is reported in [12, 13]. The prototype selected was a semi-wagon of model C80B made in China. The research results showed that the method for predicting fatigue strength of the body, based on the hybrid modeling of dynamics and an analysis using a method of finite elements, is feasible. The task on determining the dynamic loading and strength of the bearing structure of

a wagon body transported by a railroad ferry was not set in those studies.

The strength of a freight wagon was theoretically and experimentally investigated in [14]. In this case, the authors took into consideration the accepted normative magnitudes for loads acting on a wagon under operation relative to rail tracks. The paper did not address the strength of a wagon body with respect to the loads acting on it when it is transported by a railroad ferry.

An analysis of literary sources [4–14] leads to the conclusion that the issues related to wagons under load on railroad ferries, as well as to improving the scheme of interaction with the deck, require more consideration at the current stage of development of transportation industry.

3. The aim and objectives of the study

The aim of this study is to identify the patterns in determining the dynamic loading of a semi-wagon when it is fixed to the deck of a railroad ferry by a loose coupling.

To accomplish the aim, the following tasks have been set:

- to improve the scheme of interaction between the body of a semi-wagon and the deck of railroad ferry;
- to model mathematically the dynamic loading of the body of a semi-wagon when it is transported by a railroad ferry;
- to simulate the dynamic loading of the body of a semi-wagon when it is transported by a railroad ferry;
- to verify the models of the dynamic loading of the body of a semi-wagon.

4. Improving the scheme of interaction between the body of a semi-wagon and the deck of a railroad ferry

To ensure the reliability while fixing a wagon relative to the deck, we have designed a node for the bearing structure of the body for the interaction with chain couplings [15]. In order to mitigate the action of loads from chain couplings on the body of a wagon, it is proposed to enable their connection not via a rigid coupling (Fig. 1), but viscous, by installing a special device – a damper between the body and the deck (Fig. 2).

The device for fixing a wagon relative to the deck of a railroad ferry consists of rigid rod 1 at the end of which there is hook 2 to fix the body of the wagon. A controlling element of the device is a hydraulic damper, which includes body 3. Inside the body is piston 4 with throttle openings 5. The lower part of the device includes an adapter with thread cutting to adjust the length of the device, rigid rod 7 and hook 8 for fastening using a deck ring.



Fig. 1. Fixing a semi-wagon relative to the deck of a railroad ferry: *a* – via the elements of a hatch cover lock; *b* – via a towing bracket

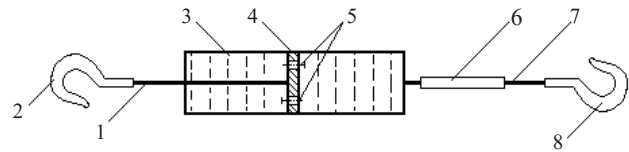

Fig. 2. Device for fastening a wagon relative to the deck of a railroad ferry: 1 – rod; 2 – hook to fasten the body; 3 – body; 4 – piston; 5 – throttle openings; 6 – adapter with thread cutting; 7 – rigid rod; 8 – hook for fastening using a deck ring

The scheme of fixing the body of a semi-wagon relative to the deck using the proposed device is shown in Fig. 3.

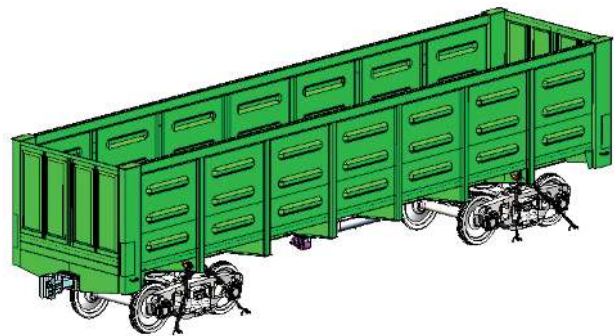

Fig. 3. Scheme of fixing the body of a semi-wagon relative to the deck using the proposed device

To fix a single wagon relative to the deck, eight such devices are used – four per each side of the wagon.

5. Mathematical modeling of the dynamic loading of the body of a semi-wagon when it is transported by a railroad ferry

In order to determine the acceleration of the body of a semi-wagon when fixing it relative to the deck using the proposed device, we performed mathematical modeling. To this end, we have constructed a mathematical model of the oscillations of a railroad ferry with the bodies of wagons, placed atop it (Fig. 4).

In this case, the system of differential equations (1) takes into consideration the angular displacements of a railroad ferry relative to the longitudinal axis, as well as the body of a wagon relative to the deck.

$$\begin{cases} \frac{D}{12 \cdot g} \cdot (B^2 + 4 \cdot z_g^2) \cdot \ddot{q}_1 + \left(\Lambda_0 \cdot \frac{B}{2} \right) \cdot \dot{q}_1 = p' \cdot \frac{h}{2} + \Lambda_0 \cdot \frac{B}{2} \cdot \dot{F}(t), \\ I_k \cdot \ddot{q}_2 + \beta \cdot \frac{b_k}{2} \cdot \dot{q}_2 = p_k \cdot \frac{h_k}{2} + F_\beta, \end{cases} \quad (1)$$

where q_1, q_2 are the generalized coordinates that correspond to the angular displacement around the longitudinal axis X of, respectively, a railroad ferry and the body of a wagon.

For a railroad ferry:

D is the weight water displacement; B is the width; h is the height of the board; Λ_0 is the coefficient of resistance to oscillations; z_g is the coordinate of the center of gravity; p' is the wind load; $F(t)$ is the law of action of the effort that disturbs the movement of a railroad ferry with the bodies of wagons, lined up on its decks.

For a wagon body:

I_k is the moment of inertia relative to the longitudinal axis; β is the coefficient of viscous resistance of an element; b_k is the width of the body; p_k is the wind load on a lateral wall; h_k is the height of a lateral wall; F_β is the moment of forces that occurs between the body and the deck.

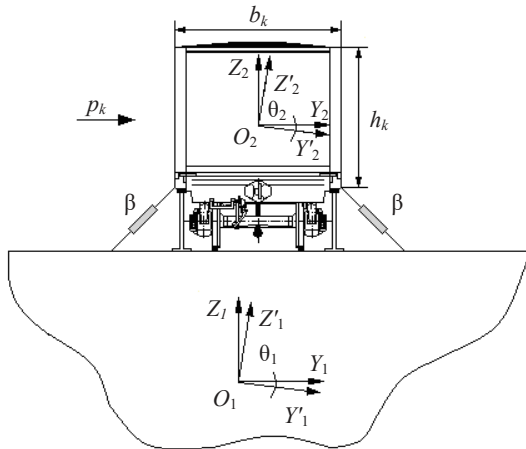

Fig. 4. Estimation scheme to determine the dynamic loading of the body of a semi-wagon

We solved the system of differential equations of motion (1) in the programming environment Mathcad [16, 17] using a Runge-Kutta method (2). Where $q_1 = y_1$; $q_2 = y_2$; $\dot{q}_1 = y_3$; $\dot{q}_2 = y_4$.

In this case, there is a transition from the system of second-order differential equations (1) to a system of the first-order differential equations, whose right-hand side is recorded in vector (2) for the application of standard algorithms for solving a system using the MATHCAD function rkfixed.

$$Q(t, y) = \begin{pmatrix} y_3 \\ y_4 \\ \frac{p' \cdot \frac{h}{2} + \Lambda_\theta \cdot \frac{B}{2} \cdot \dot{F}(t) - \left(\Lambda_\theta \cdot \frac{B}{2} \right) \cdot y_3}{\frac{D}{12 \cdot g} \cdot (B^2 + 4 \cdot z_g^2)} \\ \frac{p_k \cdot \frac{h_k}{2} + F_\beta - \beta \cdot \frac{b_k}{2} \cdot y_4}{I_k} \end{pmatrix}, \quad (2)$$

$$Z = rkfixed(Y0, tn, tk, n', Q),$$

where $Y0$ is a vector containing the initial conditions, tn , tk are the magnitudes that define the initial and the resulting variable of integration, n' is the fixed number of steps, Q is the symbol vector. Initial displacements and velocities are taken equal to zero [18].

Fig. 5, 6 show graphical dependences of accelerations that act on the body of a semi-wagon at angular displacements of a railroad ferry relative to the longitudinal axis.

For a comparative analysis, Fig. 5 shows the accelerations acting on the body of a semi-wagon under a typical scheme of interaction with a deck, and Fig. 6 – under a loose scheme. The accelerations are given for a wave course angle of $\chi=0^\circ$

relative to the body of a railroad ferry with the bodies of wagons atop it.

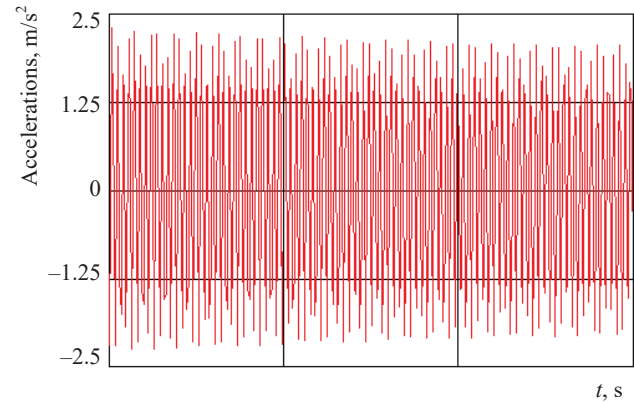

Fig. 5. Accelerations that act on the body of a semi-wagon under a typical scheme of interaction with a deck

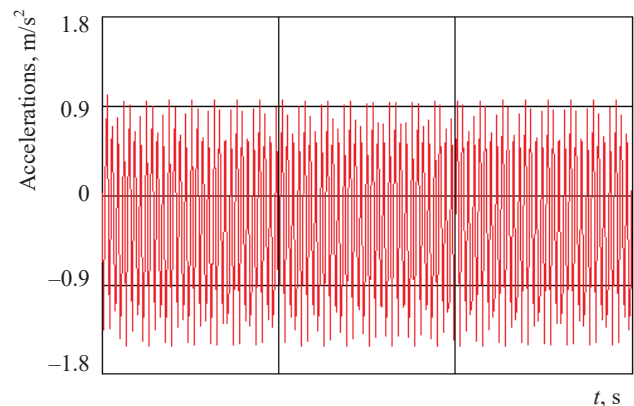

Fig. 6. Accelerations acting on the body of a semi-wagon under a loose interaction with a deck

The above figures allow us to conclude that when installing a loose coupling between the body of a wagon and the deck, it is possible to reduce the magnitudes of accelerations acting on a bearing structure of the body by 30 %.

It is important to note that in this case the working fluid that would create a viscous resistance between the body and the deck must have a coefficient of viscous resistance in the range from 1.8 kN·s/m to 4.2 kN·s/m.

6. Computer simulation of the dynamic loading on the body of a semi-wagon when it is transported by a railroad ferry

To determine the accelerations that act on the body of a semi-wagon under a loose interaction with the deck, we have conducted computer simulation. The research was performed in the programming complex CosmosWorks, version 2015 [19, 20]. The calculation was performed using a method of finite elements.

The prototype selected was a semi-wagon of model 12–757 made by PAT «KVBZ» (Ukraine). The finite elements applied were the isoparametric tetrahedra. We determined the optimum number of elements in a continual model by using a graphic-analytical method. Basic characteristics for the model are given in Table 1.

Table 1
Characteristic of the continual model of the body of a semi-wagon

Number of elements	494.489
Number of nodes	160.639
Maximal size of an element, mm	80.0
Minimal size of an element, mm	16.0
Maximal ratio of elements' sides, mm	1,000.9
Percentage of elements with a ratio of sides less than three	26.9
Percentage of elements with a ratio of sides more than ten	26.2
Minimal number of elements in a circle	9
The ratio of an increase in the size of an element	1.7

The model of strength of a semi-wagon's bearing structure at angular displacements around the longitudinal axis is shown in Fig. 7. The model takes into consideration that the body of a semi-wagon is exposed to the vertical static load P_v^{st} , the effort of spread of bulk cargo P_s , a dynamic load, as well as the loads that act via devices that enable the fixation relative to the deck P_f . Since the devices for fixing a wagon are arranged spatially [21], the effort that would be transferred to the body through them was decomposed into components (Fig. 8). The bulk cargo accepted was coal, as one of the most common types of commodities delivered by semi-wagons during international-railroad-water transportation.

To account for the presence of a viscous element between a body and a deck, we placed linings onto pivot beams made of material that has a coefficient of viscous resistance of 3.5 kN·s/m.

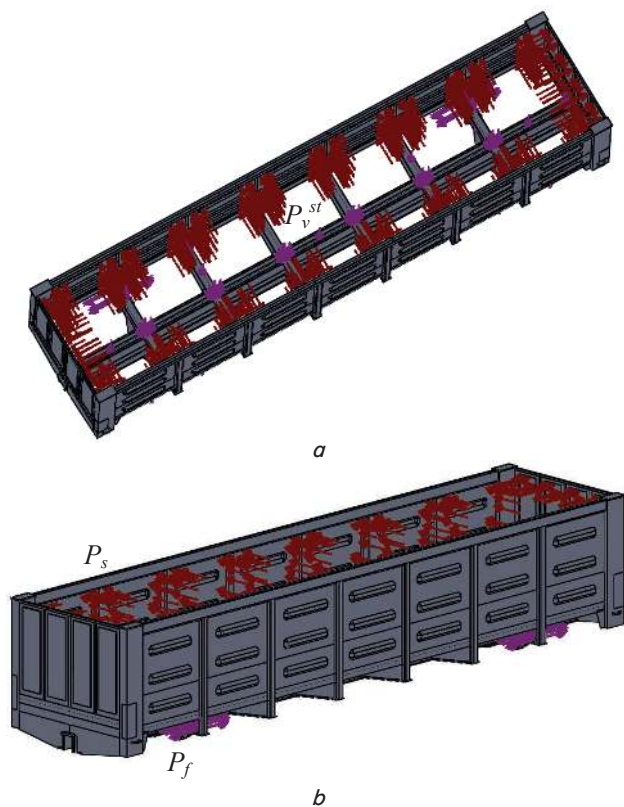

Fig. 7. Strength model of the bearing structure of the body of a semi-wagon: a – top view; b – side view

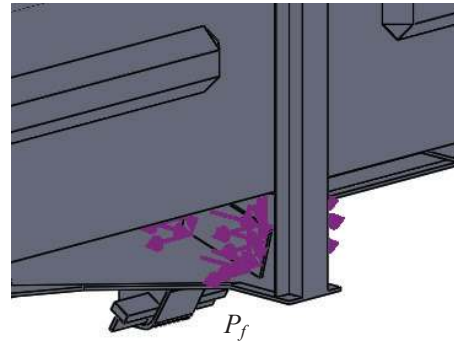

Fig. 8. Simulation of applying a load from the device for fixing a body relative to the deck

The results of calculation have shown that the maximum accelerations of the body of a semi-wagon occur in the middle parts of side walls and make up about 1.4 m/s², as well as in the middle part of a girder beam – 1.7 m/s² (Fig. 9, 10).



Fig. 9. Distribution of acceleration fields acting on the bearing structure of the body of a semi-wagon under a viscous interaction with the deck of a railroad ferry (side view)

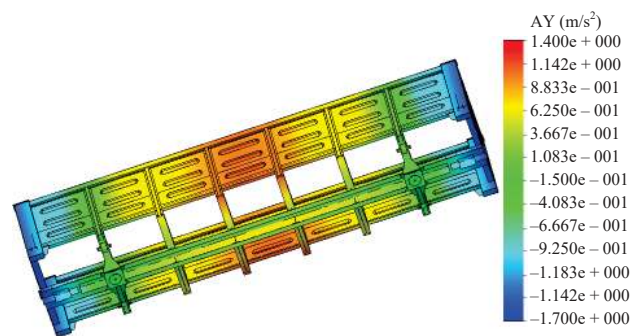

Fig. 10. Distribution of acceleration fields acting on the bearing structure of the body of a semi-wagon under a viscous interaction with the deck of a railroad ferry (bottom view)

The smallest magnitude of accelerations was observed at the end parts of the body of a semi-wagon.

7. Verification of models of the dynamic loading of the body of a semi-wagon

To verify the models presented, we applied an *F*-criterion (3) [22, 23]. The variational parameter adopted was the

heel angle of a railroad ferry. Based on the performed calculations, we determined the accelerations that act on the body of a wagon at oscillations of a railroad ferry (Fig. 11).

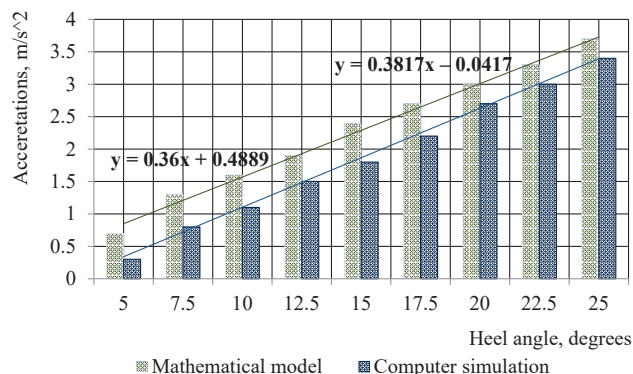

Fig. 11. Accelerations acting on the body of a semi-wagon when it is transported by a railroad ferry

It was established that at the reproducibility variance $S_r^2 = 0.98$ and the adequacy variance $S_{ad}^2 = 1.1$, the actual value for F -criterion is $F_p = 1.12$, which is less than the tabular value $F_t = 3.29$. That is, a hypothesis about the adequacy is not challenged.

8. Discussion of results of determining the dynamic loading on a semi-wagon under a viscous interaction between the body and the deck of a railroad ferry

The accelerated rate of integration of Eurasian states into the system of international transport corridors has led to the development of railroad-ferry transportation. At present, to ensure the stability of wagon bodies relative to the decks of railroad ferries during transportation by sea, the wagons are fixed. In this case, they use typical means that do not have the ability to mitigate the magnitudes of dynamic loads acting on bodies via them.

The loads acting on the bodies of wagons transported by sea greatly exceed those that act on them in the operation relative to rail tracks. This causes damage to the structural elements of bodies that are used to fix them relative to the decks. Therefore, it was proposed to improve the scheme of interaction between the body of a wagon and the deck of a railroad ferry by introducing a viscous interaction between them.

The results of mathematical modeling allowed us to conclude that the proposed measures would make it possible to reduce the magnitude of the dynamic load that is transmitted to the body of a wagon via the devices that fix it relative to the deck by 30 %.

We also performed computer simulation of the dynamic loading on the body of a wagon taking into consideration the improved scheme of interaction with the deck. We have determined the numerical values for accelerations that act on the body of a wagon, as well as their location fields. Adequacy of the constructed models has been tested based on an F -criterion.

The proposed technical solutions regarding the application of a loose coupling between the body and the deck would reduce the dynamic loading on the bearing structure of a wagon when it is transported by sea. Accordingly, under such a scheme of fixation, there would be a decrease in the stresses that arise at the nodes where a body interacts with a coupling. A given device is multi-turn and could be used for wagons of different types that are transported by railroad ferries.

It is important to note that this study was conducted for the conditions of transporting a wagon across the Black Sea under appropriate meteorological conditions. In the future, it is necessary to study a possibility for using a given device for other operating conditions (the type of a wagon, a railroad ferry, sea area, etc.). In addition, one needs to take into consideration the stochasticity of an oscillatory process predetermined by sea waves, its impact on the work of the device, the fatigue strength of the bearing structure of a body, etc.

Prospects to continue the present study would include the need to improve the bearing structure of a wagon body by mounting the fixing nodes on it to enable viscous resistance.

The study conducted would contribute to ensuring the preservation of bearing structures of wagon bodies when they are transported on a railroad ferry by sea, to reducing the cost of repair of wagons, as well as to improving the efficiency of operation of freight wagons along international transport corridors.

9. Conclusions

1. We have improved the scheme of interaction between the body of a semi-wagon and the deck of a railroad ferry by introducing a loose coupling between them. That is, rather than using a chain coupling, it has been proposed to apply device whose element is a damper, which at oscillations of a railroad ferry ensures a viscous resistance to the displacement of the body and mitigates the dynamic loads that act on it.

2. We have modelled mathematically the dynamic loading on the body of a semi-wagon during transportation by a railroad ferry taking the proposed measures into consideration. It was established that the maximum acceleration that acts on the body of a wagon, taking into account a viscous interaction with the deck, is 1.7 m/s^2 , which is less by 30 % than the magnitude of accelerations that act on the body under a typical scheme of fixing.

3. We have conducted computer simulation of the dynamic loading on the body of a semi-wagon transported by a railroad ferry taking the proposed measures into consideration. The results of simulation showed that the maximum accelerations of the body of a semi-wagon occur in the middle parts of side walls and make up about 1.4 m/s^2 , as well as in the middle part of a girder beam – 1.7 m/s^2 .

4. The models of dynamic loading on the body of a semi-wagon were verified based on F -criterion. It was established that at the reproducibility variance $S_r^2 = 0.98$ and the adequacy variance $S_{ad}^2 = 1.1$, the actual value for the F -criterion is less than the tabular one. Thus, a hypothesis on adequacy is not challenged.

References

1. Mezhdunarodnaya paromnaya pereprava Illichevsk – Varna / Sukolenov A. E., Zahariev E., Gutin I. G. et. al. Moscow: Transport, 1989. 103 p.
2. Shmakov M. G. Special'nye sudovye ustroystva. Leningrad: Sudostroenie, 1975. 344 p.

3. Gibel' «Merkuriya – 2». Kak eto bylo... URL: <https://www.pravda.ru/accidents/9720-parom/>
4. The influence of implementation of circular pipes in load-bearing structures of bodies of freight cars on their physico-mechanical properties / Fomin O. V., Lovska A. O., Plakhtii O. A., Nerubatskiy V. P. // *Scientific Bulletin of National Mining University*. 2017. Issue 6. P. 89–96.
5. Lovska A. O. Computer simulation of wagon body bearing structure dynamics during transportation by train ferry // *Eastern-European Journal of Enterprise Technologies*. 2015. Vol. 3, Issue 7 (75). P. 9–14. doi: <https://doi.org/10.15587/1729-4061.2015.43749>
6. Antipin D. Y., Racin D. Y., Shorokhov S. G. Justification of a Rational Design of the Pivot Center of the Open-top Wagon Frame by means of Computer Simulation // *Procedia Engineering*. 2016. Vol. 150. P. 150–154. doi: <https://doi.org/10.1016/j.proeng.2016.06.738>
7. Chandra Prakash Shukla, Bharti P. K. Study and Analysis of Doors of BCNHL Wagons // *International Journal of Engineering Research & Technology (IJERT)*. 2015. Vol. 4, Issue 04. P. 1195–1200. doi: <https://doi.org/10.17577/ijertv4is041031>
8. Harak S. S., Sharma S. C., Harsha S. P. Structural Dynamic Analysis of Freight Railway Wagon Using Finite Element Method // *Procedia Materials Science*. 2014. Vol. 6. P. 1891–1898. doi: <https://doi.org/10.1016/j.mspro.2014.07.221>
9. Rakshit U., Malakar B., Roy B. K. Study on Longitudinal Forces of a Freight Train for Different Types of Wagon Connectors // *IFAC-PapersOnLine*. 2018. Vol. 51, Issue 1. P. 283–288. doi: <https://doi.org/10.1016/j.ifacol.2018.05.074>
10. Experimental confirmation of the theory of implementation of the coupled design of center girder of the hopper wagons for iron ore pellets / Fomin O., Kulbovsky I., Sorochinska E., Sapronova S., Bambura O. // *Eastern-European Journal of Enterprise Technologies*. 2017. Vol. 5, Issue 1 (89). P. 11–18. doi: <https://doi.org/10.15587/1729-4061.2017.109588>
11. Research into a possibility to prolong the time of operation of universal open top wagon bodies that have exhausted their standard resource / Okorokov A., Fomin O., Lovska A., Vernigora R., Zhuravel I., Fomin V. // *Eastern-European Journal of Enterprise Technologies*. 2018. Vol. 3, Issue 7 (93). P. 20–26. doi: <https://doi.org/10.15587/1729-4061.2018.131309>
12. Zhong Y.-G., Zhan Y., Zhao G. Fatigue Analysis of Structure of Gondola Car Body Based on Rigid-flexible Coupling Multi-body Systems // *11th World Congress on Computational Mechanics (WCCM XI)*. Barcelona, 2014.
13. Yuan Y. Q., Li Q., Ran K. Analysis of C80B Wagon's Load-Stress Transfer Relation // *Applied Mechanics and Materials*. 2011. Vol. 148-149. P. 331–335. doi: <https://doi.org/10.4028/www.scientific.net/amm.148-149.331>
14. Evaluation of Structural Strength in Body Structure of Freight Car / Yoon S. C., Kim J. G., Jeon C. S., Choe K. Y. // *Key Engineering Materials*. 2009. Vol. 417-418. P. 181–184. doi: <https://doi.org/10.4028/www.scientific.net/kem.417-418.181>
15. Lovska A. O., Vizniak R. I. Vuzol nesuchoi konstruktsiyi kuzova vahona dlia yoho zakriplennia vidnosno paluby zaliznychnoporomnoho sudna: Pat. No. 108214 UA. MPK: B60P 3/06, B60P 7/135, B60P 7/08, B61F 1/12, B63B 25/00. No. a201206115; declared: 21.05.2012; published: 10.04.2015, Bul. No. 7.
16. Kir'yanov D. V. Mathcad 13. Sankt-Peterburg: BHV. Peterburg, 2006. 608 p.
17. D'yakonov V. MATHCAD 8/2000: special'niy spravochnik. Sankt-Peterburg: Piter, 2000. 592 p.
18. Domin Yu. V., Cherniak H. Yu. Osnovy dynamiky vahoniv: navch. pos. Kyiv: KUETT, 2003. 269 p.
19. Alyamovskiy A. A. SolidWorks/COSMOSWorks 2006–2007. Inzhenerniy analiz metodom konechnyh elementov. Moscow: DMK, 2007. 784 p.
20. Gallager R. Metod konechnih elementov. Osnovy. Perevod s angliyskogo / N. V. Banichuk (Ed.). Moscow: Mir, 1984. 428 p.
21. Nastavlenie po krepeleniyu general'nyh gruzov pri morskoy perezovozke dlya t/h «Geroi Shipki». Cargo securing manual for m/v «Geroi Shipki» No. 2512.02. Odessa, 1997. 51 p.
22. Chernova N. I. Matematicheskaya statistika. Novosibirsk: Novosib. gos. un-t. Novosibirsk, 2007. 148 p.
23. Kosmin V. V. Osnovy nauchnyh issledovaniy: ucheb. pos. Moscow: GOU «Uchebno-metodicheskiy centr po obrazovaniyu na zheleznodorozhnom transporte», 2007. 271 p.