

*An important role in the market of transport services belongs to container transportation. Railroads, especially under the conditions of increased competition from road transport, must respond quickly to the needs of the market and the growing demand for container transportation, including interstate traffic. Demand for container transportation can vary significantly during the year, which testifies to the expediency of introducing removable equipment on universal railroad freight cars that are involved in the deliveries of containers. This paper reports the design of a removable frame structure for a universal platform that could carry two 20-ft or one 40-ft container. The proposed technical solution does not require changes in the structure of the car and changes in its model; with a decrease in the demand for container transportation, it would allow this car to be used for its main purpose.*

*According to the current methodology, the efforts that operate on the frame during the transportation of containers have been determined. The strength of the proposed structure was estimated by a finite-element method. The maximum stresses arising in the proposed structure are 164.4 MPa; they occur in the corners of the stops attached to the stand-up staples of the platform. The resulting stress values do not exceed the allowable ones. The results of calculating the removable equipment indicate its sufficient strength. Requirements for placing cargo on the rolling stock assume a mandatory check to fit the dimensions, which confirmed that the container hosted by the frame does fit them. The proposed structure makes it possible to abandon disposable fastening parts, improve the safety of container transportation, and increase competitiveness in the container transportation market*

*Keywords: universal platform, container transportation, removable equipment, strength, finite-element method*

Received date 23.11.2020

Accepted date 14.01.2021

Published date 22.02.2021

Copyright © 2021, V. Shaposhnyk, O. Shykunov, A. Reidemeister, M. Leontii, O. Potapenko

This is an open access article under the CC BY license

(<http://creativecommons.org/licenses/by/4.0>)

## 1. Introduction

A wide range of cargoes transported by rail requires a significant variety of types of freight cars. The transportation of cargoes involves both universal (semi-wagons, platforms, covered wagons, and others) and specialized railroad cars (fitting platforms, transporters, dump carts, and others). Specialized cars have a special structure designed to transport one or more groups of cargoes similar in their properties, which makes it possible to make their transportation more cost-efficient. The competitive market of transportation services requires taking into consideration all components that affect the final cost of

cargo deliveries. Therefore, the most important direction in the development of railroad car construction is the transition to such economic and progressive structures that meet the modern requirements of the transport services market. Moreover, improving the efficiency of railroads in general, in many ways, is associated with an increase in container transportation.

A relevant task is to transport containers on universal platforms without the use of disposable fasteners and to improve traffic safety. This creates preconditions for increasing the competition in the container transportation market and for reducing the cases of container displacement during transportation because of unreliable fastening parts.

UDC 629.463.63

DOI: 10.15587/1729-4061.2021.225090

# DETERMINING THE POSSIBILITY OF USING REMOVABLE EQUIPMENT FOR TRANSPORTING 20- AND 40-FEET-LONG CONTAINERS ON AN UNIVERSAL PLATFORM WAGON

**V. Shaposhnyk**

PhD, Associate Professor\*

E-mail: vladislav.sh91@gmail.com

**O. Shykunov**

PhD, Associate Professor\*

E-mail: tri\_s@ua.fm

**A. Reidemeister**

PhD, Associate Professor\*

E-mail: reidemeister.a@gmail.com

**M. Leontii**

PhD, Associate Professor\*

E-mail: leontymuradian@gmail.com

**O. Potapenko**

PhD, Lecturer

Department of Power Supply

State Higher Educational Institution

“Kyiv Electromechanical College”

Povitroflotskyi ave., 35, Kyiv, Ukraine, 02000

E-mail: o.o\_potapenko@kemt.kiev.ua

\*Department of Cars and Cars Facilities

Dnipro National University of Railway Transport

named after Academician V. Lazaryan

Lazaryana str., 2, Dnipro, Ukraine, 49010

## 2. Literature review and problem statement

In terms of its transit potential, Ukraine ranks first in Europe and third in Eurasia; the total length of the network of international railroad transport corridors exceeds 3,000 km. The favorable geographical position along international cargo flows, the existence of a developed transport network, as well as the non-freezing Black Sea ports, predetermine the significant transit potential of this state. Three international transport corridors (III, V, IX) pass through Ukraine, as well as six corridors of the Organization for Railroad Cooperation. The Ukrainian ports of Izmail and Reni interact with the Cretan corridor No. VII. Given this, container transportation should be considered as the most important strategic resource that could help establish the railroad connection between Europe and Asia. Work [1] gives statistical data on the growth of container transportation volumes. A container train on the route China-Kazakhstan-Ukraine-Slovakia was launched. In addition, 8 internal container trains were launched in 2018. The “Viking” train for the combined transportation (Lithuania-Belarus-Ukraine-Moldova/Romania/Bulgaria/Georgia/Azerbaijan) has been successfully in operation for many years now, as well as the container train “ZUBR” (Estonia-Latvia-Belarus-Ukraine-Moldova) whose volumes of transportation in 2018 increased by 45 %, and others. The transportation of containers by container trains accounts for 40 % of the total volume of container transportation in the territory of Ukraine.

In addition, the development of a whole range of both universal and specialized containers, which are described in works [2–4], contributes to the growth of container transportation. However, when designing them, there is not enough attention paid to the ways of transporting containers by rail, except on specialized platform cars.

Paper [5] reports methods of improving the structures of specialized platform cars for the transportation of containers in order to improve their technical and economic indicators and simplify the technology of container handling. However, there remain unresolved issues related to the improvement of universal platform cars aimed at transporting containers. In addition, the authors do not aim to improve the versatility of specialized platforms.

In works [6, 7], it is proposed to use bimodal transportation technologies for container transportation. However, the proposed variants of vehicles are not commonly used at the railroads with a 1,520-mm track, which does not make it possible to resolve the task of container transportation in the coming years without raising significant funds.

A new stage in the development of railroad car construction is to design cars with a removable body, which implies a mechanized replacement of one type of body with another. Work [8] addresses the construction of cars with removable bodies. The author notes the advantages of such cars. This is an opportunity to reduce the shortage of cars, lower investments in the purchase of rolling stock, as well as the possibility of flexible adaptation to a change in the volume of transportation or competition in the transport services market. In addition, the maximum operation of cars throughout the life cycle is ensured, and the issue of seasonal demand for cars of different types is resolved. In the cited work, attention is paid to the assessment of the strength of the frame of a platform car but no specific structural solutions for the transportation of containers were offered.

Paper [10] considers the advantages of different types of cars when using them for the transportation of containers. Based on the indicators examined, it was determined that the coupled platform is the most promising means for their transportation. However, such a solution requires significant capital investment to build a large enough number of such platforms.

The arrangement and fastening of containers and replaceable bodies in the rolling stock of railroads are regulated by Chapter 9 of Annex 3 to SMGS [9]. We shall take a closer look at one of the possible options for transporting containers on a universal platform in accordance with the requirements of that document [9]. A cross-stop bar is placed on the floor in the transverse plane of the platform symmetry, which is attached to the floor by 32 nails. Two containers are placed close to it. Close to the end sides of the platform, stop bars are laid, each of which is attached to the floor with eight nails. Spreader bars are placed in the space between the bars and fittings of containers, each of which is attached to the floor of the platform by four nails. The end sides of the platform are supported with short racks. Each container is additionally fastened with four stretching wires with a diameter of 6 mm in eight threads. Several similar methods of fastening on universal platforms are considered in work [11], which also notes that the transportation of cargoes by universal rolling stock requires many single-use fittings for fastening cargoes inside a car. To the greatest extent, this concerns the transportation of large-tonnage containers by universal rolling stock. Thus, during the transportation of containers on universal platforms, it is necessary to use a large number of stretching wooden or wire props for fastening the cargo.

It is also necessary to take into consideration the human factor associated with the use of poor-quality materials, incorrect selection of components, violations in the technology of fixing containers, which leads to an inadmissible displacement of cargo during transportation. Unfortunately, such cases of container displacement are repeated on the railroad and pose a threat to traffic safety.

A specialized platform differs from the universal one by its parameters and structure. In structural terms, the specialized platform is characterized by the larger base and length of the car, the absence of boards and flooring, and it is equipped with elements for fastening containers.

Work [12] notes that railroad car-building plants have mastered the production of a wide range of specialized platforms. VAT “Dniprovagonmash” designed a platform of model 13-4117, intended for the transportation of 20, 30, and 40-ft containers with a carrying capacity of 72 tons. VAT “Azovmash” designed a fitting platform of model 13-1796 with a carrying capacity of 70 tons for transporting 20, 30, and 40-ft containers. VAT “KVBZ” designed a platform wagon of model 13-7133, to transport 20, 30, 40, and 45-ft containers. The structure of the car is made by using steel of the enhanced strength class for the main elements of the bearing structure, which made it possible to increase the carrying capacity of the railroad car to 73.6 tons. Railroad car-building plants are developing new structures of the coupled platform wagon for the simultaneous transportation of two 40-ft containers. Abroad, special platform wagons are widely used to transport containers, which make it possible to carry containers in two tiers.

Works [13, 14] describe the experience of platform wagon operation, report the results of assessing the stressed-

strained state of cars; however, when the loads that act on the platform wagon were determined, the efforts arising in the transportation of containers using removable equipment were not taken into consideration.

Specialized platforms have much wider possibilities to select various variants of container transportation in terms of their weight, size, and quantity compared to universal platforms. However, specialized platforms are also limited by the axle loading, as well as the difference in loading their bogies, which should not exceed 10 tons, taking into consideration the possible displacement of the center of cargo weight during transportation.

The authors of study [15] improved supporting structures of the platform wagon whose special feature is the presence of rotary sectors made of a composite material with viscous or elastic-viscous links, which makes it possible to absorb kinetic energy, which is transferred to the frame when conducting fire from the railroad car, as well as makes it possible to carry out side loading/unloading of military equipment. In addition, the cited study explores the dynamic loading and strength of the supporting structure of the platform car but does not describe the technical parameters of the equipment mounted on the platform wagon. The scheme of fastening and applying appropriate loads to the car frame by the installed equipment is unclear.

Works [16–18] address the issues of new materials, improving the reliability of cars, and improving the structure of cars in order to make them more versatile. The results reported in the cited works made it possible to increase the reliability and versatility of cars, including platform cars. However, the authors did not resolve the issue of improving the versatility of platform wagons in terms of the transportation of containers.

The most common way to increase the competitiveness of a universal platform car is to refit these cars in order to be able to transport containers, pipes, timber, etc. Study [19] defines that the need to refit universal platform cars for the transportation of long-sized cargoes is a relevant task, and the most promising direction is the transportation of containers. A technique is offered to imply that universal platform cars are equipped with supporting plates with fitting stops for fastening containers. Work [20] reports the results of testing the modernized platform cars of models 13-401-50 and 13-4012-50 and justifies the possibility of such modernization. However, this modernization technique assumes making significant changes in the structure of the car and requires welding operations on its supporting beams, which, in the absence of sufficient skills of performers and improper control over the quality of welded operations, could lead to a significant reduction in the strength of the structure and to decommissioning the railroad car.

Based on the above-mentioned studies, we can conclude that refitting universal platform wagons is relevant in terms of the increased demand for models currently in operation. However, such re-equipment should involve installing removable equipment without interfering with the supporting structures of the railroad car. Such a solution would make it possible to use a car as a standard universal platform, and, in times of increasing demand, following the installation of removable equipment, as a platform wagon for the transportation of containers.

### 3. The aim and objectives of the study

The aim of this work is to determine the possibility of using removable equipment for the transportation of

large-tonnage containers that are 20 and 40 feet long on a universal platform.

To accomplish the aim, the following tasks have been set:

- to design removable equipment for the transportation of two 20-ft or one 40-ft container weighing 30.5 tons on a universal railroad platform;
- to test whether the railroad car with a container and removable equipment fits the overall outline;
- to calculate the efforts acting on removable equipment;
- to assess the stressed-strained state of the proposed structure using a finite-element method.

### 4. Materials and methods to study the possibility of using removable equipment for the transportation of containers on a universal platform

We have designed a special removable structure for fastening containers on the platform, which can be installed, if necessary, on a railroad car, and which does not require changes to the structure of the car itself. The proposed structure is shown in Fig. 1.

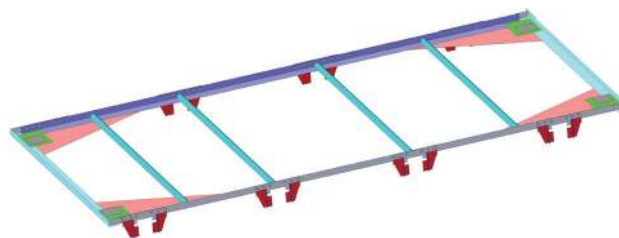

Fig. 1. Semi-frame for a container

The removable equipment includes two semi-frames where one semi-frame's dimensions are 613×3,060×182 (the size of the top of the stop for the container's fittings).

#### 4.1. Features of the structure of a semi-frame for a container

The weight of the two assembled semi-frames is 1,411.6 kg (one semi-frame weighs 695.6 kg). The weight of the frame with containers is 62.4 tons with a carrying capacity of universal platforms of at least 63 t. Each semi-frame is made from a steel angle, whose cross-section is 125×80×12 mm, and a steel sheet whose thickness is 10 and 20 mm. Before installing the frames, the longitudinal sides of the platform are opened and fixed while the end sides are closed. Two semi-frames are installed on a car back-to-back symmetrically to the transverse axis of the car symmetry and are connected to each other with bolts, Fig. 2, *a*. To prevent the displacement, the frame is fixed with stops that are attached without a gap to the stand-up staples of the platform: Fig. 2, *b*. Each stop is attached to the longitudinal corners of the frame with bolts or welding. The frame is made of two semi-frames in order to reduce the overall size when storing and manufacturing. If necessary, the frame can be made solid. The frame has eight hinged stops to install containers. The frame can be equipped with both standard fitting stops and improved stops, or be additionally equipped with devices to prevent the overturning of containers [21]. When transporting one 40-ft container, the central stops of the frame are put in the transport position.

When using the platform for transporting 40-ft containers only, the frame can be equipped with a simplified version of the stop, Fig. 3.

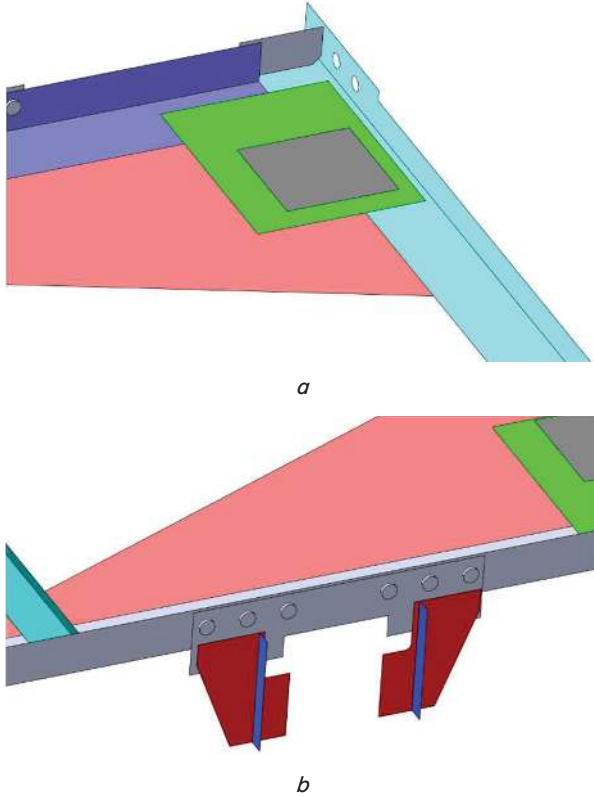

Fig. 2. Semi-frame for a container: *a* – inner corner with holes for connecting bolts; *b* – fixing stop

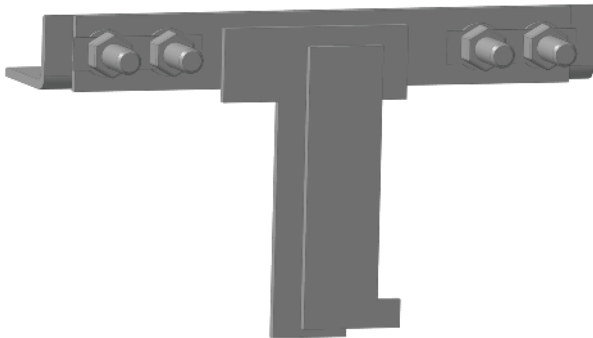

Fig. 3. A variant of the frame execution

**4. 2. Procedure for calculating the forces arising during the transportation of containers installed on a removable frame**

We calculated inertial forces in accordance with the procedure set out in Chapter 1 of Annex 3 to SMGS [9].

The longitudinal inertial force is derived from the following formula:

$$F_{li} = a_{li} \cdot Q_{wc}, \tag{1}$$

where  $Q_{wc}$  is the weight of cargo, taking into consideration the fittings;  $a_{li}$  is the specific longitudinal force, which is derived from the following formula

$$a_{li} = a_{22} - \frac{Q_{wc} \cdot (a_{22} - a_{94})}{72}, \tag{2}$$

where  $a_{22}$ ,  $a_{94}$  are the specific longitudinal inertial forces,  $a_{22}=1.9$  ton-force/t,  $a_{94}=1.67$  ton-force/t.

The transverse inertial force is derived from the following formula:

$$F_{ti} = a_{ti} \cdot Q_{wc}, \tag{3}$$

where  $a_{ti}$  is the specific transverse inertial force, which is derived from the following formula:

$$a_{ti} = a_c + \frac{2 \cdot (a_k - a_m)}{L_c} \cdot l_c, \tag{4}$$

where  $a_m$ ,  $a_k$  are the specific transverse inertial forces of the cargo shroud placed inside the railroad car and above the girder, respectively,  $a_m=0.33$  ton-force/t,  $a_k=0.55$  ton-force/t;  $l_c$  is the coordinate of the center of cargo weight;  $L_c$  is the car base.

The vertical inertial force is derived from the following formula

$$F_v = a_v \cdot Q_{wc}, \tag{5}$$

where  $a_v$  is the specific vertical inertial force

$$a_v = 250 + k \cdot l_c + \frac{2,140}{Q_{wc}}, \tag{6}$$

where  $k=5$  is the load factor per car.

The wind load is derived from the following formula:

$$W_w = 50 \cdot S_a / 1,000, \tag{7}$$

where  $S_a$  is the area of the on-air surface of the cargo, m<sup>2</sup>.

We determined the forces of friction:

– in the longitudinal direction:

$$F_f^{li} = Q_{wc} \cdot \mu, \tag{8}$$

where  $\mu$  is the friction coefficient;

– in the transverse direction:

$$F_f^{ti} = Q_{wc} \cdot \mu \cdot (1 - a_v). \tag{9}$$

The longitudinal inertial force to be damped:

$$\Delta F_{li} = F_{li} - F_f^{li}. \tag{10}$$

The transverse inertial force that must be damped:

$$\Delta F_{ti} = n \cdot (F_{ti} + W_w) - F_f^{ti}, \tag{11}$$

where  $n$  is the coefficient accepted to equal 1.25;  $W_w$  is the wind load.

**4. 3. The procedure of the theoretical assessment of structural strength using a finite-element method**

The principal method of theoretical assessment of the strength of a structure is the calculation using a finite-element method [22–27]. The solid-state simulation was performed in the system of automated design *Solid-Works* (France). The calculation of the stressed-strained state involved the *FEMAP* software package. The material of the proposed frame structure is the steel of grade St3 whose mechanical properties are given in [28]: the permissible stresses are  $[\sigma]=165$  MPa.

The geometric 3D model of the semi-frame was split into flat three- and four-corner finite elements with a characteristic edge size of 10 mm (Fig. 4); the resulting grid includes 82.6 thousand elements and 88.8 thousand nodes.

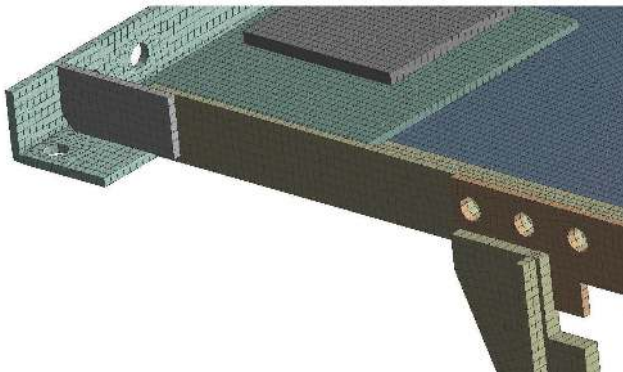

Fig. 4. Fragment of the finite-element model

During the calculation of the semi-frame for strength, we considered the simultaneous action (Fig. 5, *a*) of both the longitudinal load represented by the longitudinal force of inertia, which must be damped,  $\Delta F_{li}$ , and the transverse load represented by the transverse force of inertia, which must be damped,  $\Delta F_{ti}$ . The longitudinal forces were evenly divided into eight stops, one of each pair, and were applied to their ends. The transverse forces were evenly applied to the stops, which are located on one side of the platform; they acted outwards.

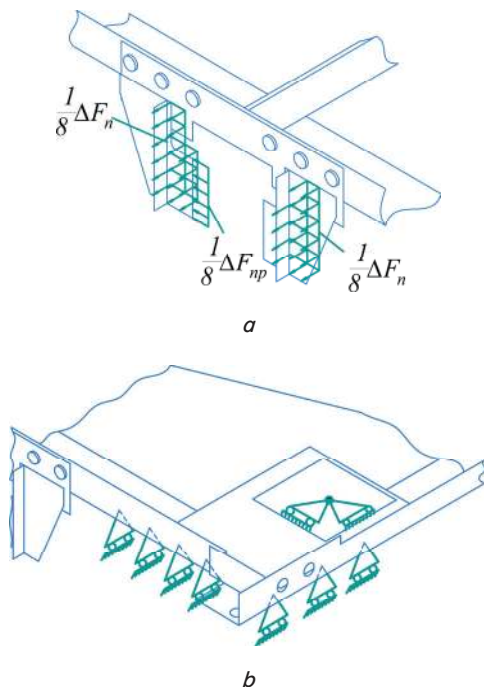

Fig. 5. Schematic of fixing and applying loads to the semi-frame *F*: *a* – external forces; *b* – restriction of movements of the estimated model

We fixed the sites of fitting installation (Fig. 5, *b*) from the longitudinal and transverse movements. The vertical movement was limited for the longitudinal and transverse angles of the semi-frame.

## 5. Results of studying the possibility of using removable equipment for the transportation of large-tonnage containers

### 5.1. The structure of removable equipment

Based on the results of the analysis of the structure of universal platform cars and the size of common models of containers, we designed the structure of removable equipment. The proposed structure consists of two semi-frames measuring 613×3,060×182 mm each. The frames were welded from rolled profiles, reinforced in the connection areas with linings. Fittings in the corners of the semi-frames are meant for the installation of containers; fixing the structure on a universal platform involves fixing supports.

### 5.2. Fitting a railroad car with a container to the overall outline

Requirements for placing cargo on rolling stock assume a mandatory check of fitting the dimensions. The outline of the main load dimension was built; a railroad car with an installed frame and a container was fit inside it, Fig. 6. In Fig. 6, a railroad car is conditionally shown with a thin black line, the outline of the main dimension of the load with a thickened green line, the frame with containers with the main and dotted blue line. Near container sizes, the numbers in parentheses are marked with an asterisk, a conditional container length value.

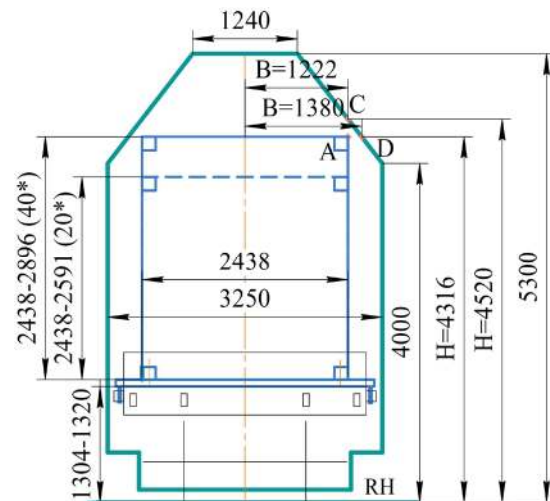

Fig. 6. Fitting a railroad car with a container to the overall outline

The distance between control points *A* and *C* (the height of the dimension), and *A* and *D* (half the size of the dimension), is, respectively, 204 mm and 161 mm. Since the railroad car with a cargo fits the size with a significant margin, no additional calculations are needed.

### 5.3. Forces acting on the structure

According to the requirements of Chapter 1 of Annex 3 to SMGS [9], we determined the loads acting on the removable equipment from containers. The resulting efforts arising during the transportation of one 40-ft container are much smaller than the loads arising during the transportation of two 20-ft containers. Therefore, to assess the strength, we considered a variant assuming the transportation of two 20-ft containers on the platform. The maximum inertial forces

were established when the platforms are loaded with two 20-ft containers: longitudinal, 79.6 ton-force; transverse, 9.7 ton-force; which are perceived by 16 riser staples of the platform car. A load allowed per a riser staple in the longitudinal and transverse directions is 5 ton-force. Thus, the permissible load in the longitudinal and transverse direction is  $16 \cdot 5 = 80$  ton-force, which exceeds the values of undamped inertial forces. Consequently, the reliability of fastening containers with a frame on the platform car is ensured.

**5. 4. Assessment of the strength of the proposed structure**

Based on the results of our calculations, the distribution of stresses in the structure of a semi-frame arising under the influence of estimated loads was established. The values of equivalent stresses that arise in the structure are shown in Fig. 7, 8.



Fig. 7. The distribution of equivalent stresses in a semi-frame for a container (general view)

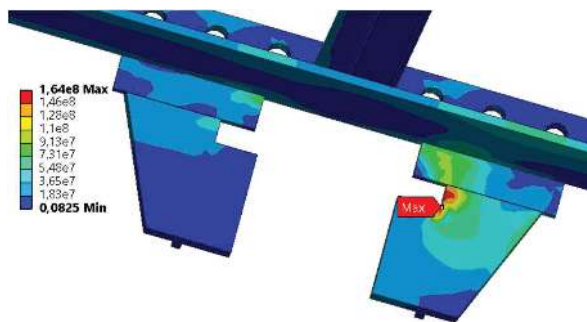

Fig. 8. The distribution of equivalent stresses in a semi-frame for a container (maximum stresses)

The maximum stresses arising in the proposed structure are 164.4 MPa; they occur in the corner of the stop. The resulting stress values do not exceed the allowable ones.

**6. Discussion of results of studying the strength of the proposed structure**

The proposed structure of removable equipment makes it possible to transport large-tonnage containers without making changes in the structure of the universal platform; in this case, the labor intensity of loading and unloading operations is comparable to such when using specialized cars, which is achieved by refusing one-time fastening components. The efficiency of transportation in some cases is even higher than that when using specialized cars. Thus, when transporting fully loaded 20-ft containers with a gross weight of 30.5 tons, the load capacity of a railroad car allows only

two such containers to be placed on it, with the length of the clutch axes of the universal platform (14.62 m) is 1.36 times smaller than that of the specialized one with a load length of 60 feet (19.88 m). This makes it possible to increase the competitiveness of universal platform cars in the container transportation market.

The merits of this study include the relevance and timeliness of the proposed technical solution, which does not require, unlike others, to make changes in the structure of the platform car. Compared to similar studies, given in the analysis of the literature, we considered the assessment of the possibility of using removable equipment in terms of its strength and overall dimensions, rather than in terms of the strength of a railroad car's frame. Our paper discusses all the initial data and describes the calculation procedure in detail, which makes it possible, if necessary, to verify the results reported here.

The results (model) apply to an actual object because of the following:

- loads on the structure were determined according to the approved procedure;
- determining the stresses employed a finite-element method, which is the principal method to theoretically assess the strength of structures. The direct calculation was performed using the verified software package *FEMAP*;

- the degree of discretization of the structure corresponds to modern engineering practice.

Our results of calculations indicate satisfactory strength and compliance with the dimensions. Possible operational deficiencies and reliability indicators should be identified and evaluated during the controlled operation of the prototype [29, 30]. It is also advisable to consider in more detail the task of optimizing the structure in order to determine reserves to reduce its mass and improve its strength. This is planned to be done by selecting the optimal cross-sections of rolled profiles, by perforating the elements, and by using stronger grades of steel.

The limitations of the study include the lack of calculation of the platform car for strength and of the dynamic indicators when transporting the frame with containers. This calculation was not carried out because the calculated efforts to fix the frame for the riser staples of the car did not exceed the permissible values while the maximum load capacity of the car was not exceeded. The frame is rigidly attached to the car, which minimizes its impact on the possible change in dynamic indicators, compared to known studies.

**7. Conclusions**

1. A structure of removable equipment has been proposed in the form of two connected welded semi-frames, which makes it possible to carry large-tonnage containers, 20 and 40 feet long, without making changes to the structure of the universal platform wagon.
2. We tested whether a railroad car with a container and removable equipment fits the overall outline; the

correctness of the selected structural dimensions of the removable frame was confirmed. In terms of the height and half-wide size, there is a reserve of 204 mm and 161 mm, respectively.

3. The loads acting on removable equipment from the side of containers have been determined. When calculating, these loads were reduced to the longitudinal inertial force that must be damped – 79.6 ton-force, and to the transverse

inertial force to be damped – 9.7 ton-force, which were employed in the estimation model.

4. The maximum stresses obtained from the results of the assessment of the strength of the structure of the semi-frame are 164.4 MPa; they occur in the expected place – the corner of the stop. They are less than the permissible stresses for the steel of grade St3,  $[\sigma]=165$  MPa, which was chosen as the material of the structure.

#### References

1. Organisation for Cooperation between Railways (OSJD) (2019). Otchet o deyatel'nosti Organizatsii sotrudnichestva zheleznykh dorog za 2018 god. (Utverzhen 6 iyunya 2019 g. XLVII sessiy Soveshchaniya Ministrov OSZhD (g. Tashkent, Respublika Uzbekistan, 4-7 iyunya 2019 g.)). Available at: [https://osjd.org/dbmm/download?vp=51&col\\_id=121&id=1578](https://osjd.org/dbmm/download?vp=51&col_id=121&id=1578)
2. Tolstykh, D. A. (2008). Tipy konteynerov i metody ih ispol'zovaniya v logisticheskikh tekhnologiyah. *Transport Rossiyskoy Federatsii*, 3-4 (16-17), 52–55. Available at: <http://rostransport.com/transportrf/pdf/17/52-55.pdf>
3. Rzczycki, A., Wiśnicki, B. (2016). Strength Analysis of Shipping Container Floor with Gooseneck Tunnel under Heavy Cargo Load. *Solid State Phenomena*, 252, 81–90. doi: <https://doi.org/10.4028/www.scientific.net/ssp.252.81>
4. Wang, Z., Qian, C. (2020). Strength analysis of LNG tank container for trains under inertial force. *Journal of Physics: Conference Series*, 1549, 032107. doi: <https://doi.org/10.1088/1742-6596/1549/3/032107>
5. Morchiladze, I. G., Tret'yakov, A. V., Sokolov, A. M. (2006). Sovershenstvovanie vagonov-platform dlya mezhdunarodnykh perevozk konteynerov. *Zheleznye dorogi mira*, 8, 52–55.
6. Nader, M., Sala, M., Korzeb, J., Kostrzewski, A. (2014). Rail transport wagon as a new, innovative constructional solution for the transport of semi-trailers and truck combinations for intermodal transport. *Logistyka*, 4, 2272–2279.
7. Krason, W., Niezgoda, T. (2014). FE numerical tests of railway wagon for intermodal transport according to PN-EU standards. *Bulletin of the Polish Academy of Sciences Technical Sciences*, 62 (4), 843–851. doi: <https://doi.org/10.2478/bpasts-2014-0093>
8. Morchiladze, I. G. (2009). Adaptatsiya zheleznodorozhnykh vagonov k mezhdunarodnym perevozkam gruzov. Moscow: IBS-Holding, 534.
9. Tehnicheskie usloviya razmeshcheniya i krepleniya gruzov: Prilozhenie 3 k Soglasheniyu o mezhdunarodnom zheleznodorozhnom gruzovom soobshchenii (SMGS) (2019). Organizatsiya sotrudnichestva zheleznykh dorog (OSZhD). Available at: [https://www.uz.gov.ua/cargo\\_transportation/legal\\_documents/smgs/dod3\\_01072019/](https://www.uz.gov.ua/cargo_transportation/legal_documents/smgs/dod3_01072019/)
10. Bubnov, V. M., Myamlin, S. V., Gurzhi, N. L. (2009). Improvement rolling-stock structure for transportation of containers. *Transbaltica: proc. of the 6th intern. Scientific conf. Vilnius*, 15–18.
11. Myamlin, S. V., Shatunov, O. V., Sorokolit, A. V. (2010). Rolling Stock for Transportation Container by Rail-freight Traffics. *Sbornik nauchnykh trudov Donetskogo instituta zheleznodorozhnogo transporta*, 22, 125–131. Available at: <http://eadnurt.diit.edu.ua/jspui/handle/123456789/4372>
12. Bubnov, V. M., Myamlin, S. V., Hurzhy, N. L. (2009). The improvement of the rolling stock design for containers transportation. *Science and Transport Progress. Bulletin of Dnipropetrovsk National University of Railway Transport*, 26, 11–14.
13. Milovanović, V., Dunić, V., Rakić, D., Živković, M. (2013). Identification causes of cracking on the underframe of wagon for containers transportation – Fatigue strength assessment of wagon welded joints. *Engineering Failure Analysis*, 31, 118–131. doi: <https://doi.org/10.1016/j.engfailanal.2013.01.039>
14. Shvets, A., Shvets, A., Kasianchuk, V. (2020). Research of Strength Characteristics of Element of the Unit Rolling Stock. *Vahonnyi park*, 1 (157), 7–12. Available at: <http://eadnurt.diit.edu.ua/bitstream/123456789/11934/1/Shvets.pdf>
15. Lovska, A., Fomin, O., Chechet, A., Soloviova, O. (2020). Determining the features of loading the improved bearing structure of a platform wagon for the transportation of military equipment. *Eastern-European Journal of Enterprise Technologies*, 3 (7 (105)), 20–26. doi: <https://doi.org/10.15587/1729-4061.2020.203245>
16. Lee, W. G., Kim, J.-S., Sun, S.-J., Lim, J.-Y. (2016). The next generation material for lightweight railway car body structures: Magnesium alloys. *Proceedings of the Institution of Mechanical Engineers, Part F: Journal of Rail and Rapid Transit*, 232 (1), 25–42. doi: <https://doi.org/10.1177/0954409716646140>
17. Muradyan, L. A., Shaposhnik, V. Yu., Podosenov, D. A. (2016). Improving the Reliability of Freight Wagons with the Use of New Manufacturing Technologies and Regeneration of Working Surfaces. *Elektromahnitna sumisnist ta bezpeka na zaliznychnomu transporti*, 11, 49–54. Available at: [http://eadnurt.diit.edu.ua/bitstream/123456789/9585/1/Muradian\\_%20L.pdf](http://eadnurt.diit.edu.ua/bitstream/123456789/9585/1/Muradian_%20L.pdf)
18. Reidemeister, A., Muradian, L., Shaposhnyk, V., Shykunov, O., Kyryl'chuk, O., Kalashnyk, V. (2020). Improvement of the open wagon for cargoes which imply loading with a “hat.” *IOP Conference Series: Materials Science and Engineering*, 985, 012034. doi: <https://doi.org/10.1088/1757-899x/985/1/012034>
19. Shaytanova, I. K. (2005). Vybora napravleniy modernizatsii universal'nykh vagonov-platform. *Izvestiya Peterburgskogo universiteta putey soobshcheniya*, 1, 65–70.

20. Reidemeister, O. H., Kalashnyk, V. O., Shykunov, O. A. (2016). Modernization as a way to improve the use of universal cars. *Science and Transport Progress. Bulletin of Dnipropetrovsk National University of Railway Transport*, 2 (62), 148–156. doi: <https://doi.org/10.15802/stp2016/67334>
21. Boronenko, Yu. P., Dauksha, A. S. (2017). Selecting design solutions for container and swap body flatcar fixing devices. *Transport Rossiyskoy Federatsii. Zhurnal o nauke, praktike, ekonomike*, 3 (70), 29–32. Available at: <https://cyberleninka.ru/article/n/vybor-konstruktivnyh-resheniy-ustroystv-krepleniya-konteynerov-i-semnyh-kuzovov-na-zheleznodorozhnyh-platformah>
22. Dižo, J., Harušinec, J., Blatnický, M. (2017). Structural analysis of a modified freight wagon bogie frame. *MATEC Web of Conferences*, 134, 00010. doi: <https://doi.org/10.1051/mateconf/201713400010>
23. Baykasoglu, C., Sunbuloglu, E., Bozdog, S. E., Aruk, F., Toprak, T., Mugan, A. (2012). Numerical static and dynamic stress analysis on railway passenger and freight car models. *International Iron & Steel Symposium*, 579–586. Available at: <http://web.hitit.edu.tr/dosyalar/yayinlar/cengizbaykasoglu@hititedutr110920130Y7K9T0V.pdf>
24. Dovhaniuk, S. S., Kalashnyk, V. O., Reidemeister, A. G., Shykunov, O. A. (2019). Investigation of possibility of hopper cars unloading on the car dumper VRS–134M. *MATEC Web of Conferences*, 294, 06003. doi: <https://doi.org/10.1051/mateconf/201929406003>
25. Lee, H.-A., Jung, S.-B., Jang, H.-H., Shin, D.-H., Lee, J. U., Kim, K. W., Park, G.-J. (2015). Structural-optimization-based design process for the body of a railway vehicle made from extruded aluminum panels. *Proceedings of the Institution of Mechanical Engineers, Part F: Journal of Rail and Rapid Transit*, 230 (4), 1283–1296. doi: <https://doi.org/10.1177/0954409715593971>
26. Myamlin, S., Lunys, O., Neduzha, L., Kyryl'chuk, O. (2017). Mathematical modeling of dynamic loading of cassette bearings for freight cars. *Transport Means: Proceedings of 21st International Scientific Conference. Kaunas*, 973–976.
27. Stoilov, V., Slavchev, S. S., Purgić, S. (2015). Static strength analysis of the body of a wagon, series Zans. *Journal of The Balkan Tribological Association*, 21 (1), 49–57.
28. DSTU 7598:2014. Freight wagons. General requirements to calculation and designing of the new and modernized 1520 mm gauge wagons (non-self-propelled). Kyiv, 162.
29. Muradian, L. A., Shaposhnyk, V. Y., Mischenko, A. A. (2016). Methodological fundamentals of determination of unpowered rolling stock maintenance characteristics. *Science and Transport Progress. Bulletin of Dnipropetrovsk National University of Railway Transport*, 1 (61), 169–179. doi: <https://doi.org/10.15802/stp2016/61044>
30. Muradyan, L. A., Shaposhnik, V. Yu., Mishchenko, A. A. (2016). Opytnye marshruty DIIT-UZ: «Opytnaya ekspluatatsiya – nauchnye obosnovaniya – massovoe vnedrenie». *Vagonniy park*, 5-6 (110-111), 57–59.