

Article

# Developing Entrepreneurial Sustainability among Saudi Arabia's University Students

Nadia Abdelhamid Abdelmegeed Abdelwahed 

Department of Management, Collage of Business, King Faisal University, Al-Ahsa 31982, Saudi Arabia; nabdelwahed@kfu.edu.sa; Tel.: +966-50-719-6646

**Abstract:** The role of entrepreneurship has transformed to include issues beyond economic growth. This has twisted attention toward the drivers of entrepreneurial intentions across entrepreneurship types, particularly in sustainable entrepreneurship. Sustainable entrepreneurship is essential and a protagonist tool in protecting the environment, economy and society. This ensures employment opportunities, solves environmental problems and facilitates social and economic development. Keeping into consideration, the present study attempts to investigate sustainable entrepreneurial intention through Attitudes toward Sustainability (ATS), Perceived Desirability (PED), Perceived Feasibility (PEF) and Opportunity Recognition (OR) among Saudi Arabia's university students. We employed the quantitative approach and used a survey questionnaire to obtain the responses from the respondents. We targeted the students of different public sector universities in Saudi Arabia using a random sampling technique. Finally, we utilized 292 valid samples to infer the results. Utilizing the Structural Equation Model (SEM) through analysis of moment structures (AMOS), we found a positive and significant effect of Attitudes towards Sustainability (ATS), Perceived Desirability (PED) and Perceived Feasibility (PEF) on Sustainable Entrepreneurial Intentions (SEI) and Opportunity Recognition (OR). This study provides valuable insights into the entrepreneurship domain and offers guidelines for policymakers and planners in shaping the policies that promote entrepreneurial sustainability and employment in Saudi Arabia. Moreover, the OR factor also significantly and positively affects SEI. Finally, the study's findings would contribute to the literature review by adding another empirical confirmation from Saudi Arabian students' viewpoint.

**Keywords:** sustainable entrepreneurial intentions (SEI); perceived entrepreneurial desirability (PED); perceived entrepreneurial feasibility (PEF); attitudes towards sustainability (ATS); opportunity recognition (OR)



**Citation:** Abdelwahed, N.A.A. Developing Entrepreneurial Sustainability among Saudi Arabia's University Students. *Sustainability* **2022**, *14*, 11890. <https://doi.org/10.3390/su141911890>

Academic Editor: Fernando Almeida

Received: 18 August 2022

Accepted: 17 September 2022

Published: 21 September 2022

**Publisher's Note:** MDPI stays neutral with regard to jurisdictional claims in published maps and institutional affiliations.



**Copyright:** © 2022 by the author. Licensee MDPI, Basel, Switzerland. This article is an open access article distributed under the terms and conditions of the Creative Commons Attribution (CC BY) license (<https://creativecommons.org/licenses/by/4.0/>).

## 1. Introduction

Presently, the different global economies confront significant employment and environmental challenges. Thus, to tackle these issues, entrepreneurship plays a vital role in overcoming these severe challenges [1,2]. Sustainability in entrepreneurship has excellent value, which is undoubtedly among the practical tools that protect the environment, the economy and society by creating employment opportunities, solving environmental issues and facilitating social and economic development [3]. Entrepreneurial sustainability is the phenomenon that looks around the diffracted aspects, i.e., environment/surroundings, business, behavior and human actions. More specifically, it undertakes social awareness, environmental sustainability, policies, environmental regulations, profits, business management, reputation, unity and leadership, which significantly shapes entrepreneurial sustainability in the economy [4]. Thus, investigation of individuals' intentions toward sustainable entrepreneurship is the need of the day.

In the previous literature, several scholars have tested SEI with many factors, such as perceived usefulness, work environment, business opportunities, OR, SEI, ATC, PED and PEF, such as entrepreneurial orientation, knowledge acquisition and networking,

etc., among the different units of analysis or respondents (i.e., entrepreneurs, employees and managers) [5–8]. According to [3], sustainable opportunities and development opportunities are connected to the sustainability of the natural environment and offer development achievements to others. Moreover, entrepreneurs determine the possibilities of sustainable development through their knowledge of the domain. Similarly, the framework of [6] emphasizes a positive linkage between sustainable entrepreneurship and sustainable innovation. In terms of creating value, sustainable and social entrepreneurship differ significantly from conventional entrepreneurship. Social entrepreneurship focuses mainly on creating value [9–11], while environmental entrepreneurship focuses on forming environmental value [12].

Academically, the attention has concentrated on the core motivations and the intentions to become an entrepreneur. EI is fundamental in understanding and predicting entrepreneurship [13], along with the aspirations to start or own a business [14,15]. Notwithstanding the interest in EI, there is still a lack of knowledge about EI in diverse entrepreneurship milieus. However, we noticed that young adults (“millennials” or “Generation Y”) have robust environmental and entrepreneurial consciousness and have great social awareness than previous generations [9,15]. Usually, college and university students are more willing to adopt entrepreneurship as a career option and means for success in business [1]. These options positively develop those entrepreneurial intentions (EI) and entrepreneurial movement as the source of entrepreneurial behavior [5]. Furthermore, they emphasize economic value in these new entrepreneurship practices, creating economic value as either a means to an end or to blend unlike values [15–17].

Despite the significance of students in entrepreneurship, contextually and specifically, the existing literature still lacks empirical evidence of the effect of PED, PEF, ATS and OR on SEI and, more particularly, among Saudi Arabia’s public sector university students. The Saudi Arabian university students are potential entrepreneurs [18], are more determined and have immense creativity and skills to become successful in business. They can face entrepreneurial challenges without any pressure [1]. They are eager to bring in social, sustainable entrepreneurial development [19]. In the Saudi Arabian context, the students’ EI is predicted by entrepreneurial self-efficacy, entrepreneurial ecosystem, support structures, adequate institutional infrastructure and culture [20], entrepreneurial resilience [21], personality antecedents, such as internal locus of control, propensity to take a risk and need for achievement [22], represent societal factors and the physical infrastructure [23]. Furthermore, the Theory of Planned Behavior (TPB) has remained significant and contributive in exploring EI. The TBP is based on constructs, such as attitudes, subjective norms and perceived behavioral control, which proved to be the stronger tool in examining the EI, particularly among the different students, i.e., business, commerce, law, management, etc. [13,17,24,25].

However, the literature still leaves neglected gaps, particularly the direct role of ATS, PED, PEF and OR in Saudi Arabian university students’ SEI. Moreover, it remains undecided on the mediating contribution of OR between ATS, PED, PEF and SEI. Therefore, based on the above gaps and the need to investigate these factors, we proposed investigating entrepreneurial sustainability among Saudi Arabia’s university students.

The study would provide an essential contribution to the theory and practice. In practice, the outcomes would offer marvelous practical significance for refining university students’ SEI and stimulating sustainable development of economic, social, and environmental protection. In the field of entrepreneurship, the government of Saudi Arabia may focus more on sustainable entrepreneurship to resolve problems concerning the environment, economy and entrepreneurship.

Theoretically, the study directly provides the integrated role of ATS, PED, PEF and OR towards SEI. Moreover, the mediating role of OR between ATS, PED, PEF and SEI would further enrich the theoretical base of TBP theory and EEM, which are integrated into a model. Finally, this study would contribute to understanding their SEI and the factors affecting their EI to own businesses.

## 2. Literature Review and Formulation of the Hypotheses

A sense of moral obligation towards sustainability is associated with a willingness to safeguard sustainability, sustainability awareness and responsibility towards sustainable development [26,27] underscore the knowledge, attitudes, perceived behavioral control and subjective norms have a significant and meaningful role in developing American university students' behaviors. In the evidence of [28], many students ponder whether sustainability is "a good thing" for sustainability or sustainable development in economic and social aspects. During the global COVID-19 pandemic, attitudes to sustainable development have converged with anthropocentric and eccentric attitudes [29]. The attitudes to stay-at-home have had a positive influence on the behavioral intentions to do so during the COVID-19 pandemic [13,30]. Generally, due to having a healthy knowledge of the environment and business opportunities, educators have positive attitudes toward sustainable development [31]. The TPB is the significant predictor of sustainability and staff development among Griffith University, Brisbane, Queensland, Australia students. Moreover, the work environment determines staff attitudes and behaviors [32]. In Thailand, ref. [13] applies the Entrepreneurial Attitude Orientation (EAO) model and demonstrates that innovation, personal control and need for achievement have a positive and significant effect on attitudes towards entrepreneurship. On the other hand, self-esteem is an insignificant enabler of attitudes toward entrepreneurship. In Pakistan's public sector universities, PEF, PED and self-efficacy affect business students' EI [33]. Ref. [13] claims that Master's degree in Business Administration (MBA) students are greatly inclined toward sustainable entrepreneurship. It helps change and positively develops consumer behaviors, favorable market conditions, green marketing and eco-friendly people [13].

Similarly, [8] underlines that perceived usefulness and self-efficacy have a positive effect on attitudes and intentions to adopt mobile learning. In the university context, [34] conducted a study using the three-dimensional institutional framework. Their findings reveal the importance of normative and regulative structures, which are better than cognitive structures in enhancing students' EI and OR. By using hierarchical regression, the findings of [35] show that social entrepreneurial self-efficacy has a mediating predictive and powerful influence in shaping the connection between social OR and moral judgment. Moreover, the significant determinants, which increase the social OR, are moral judgment and social entrepreneurial self-efficacy. Likewise, in Ghana, Africa, the acquisition of OR and entrepreneurship knowledge ultimately affect self-efficacy and EI. Furthermore, entrepreneurial self-efficacy improves the development of EI [36]. In [37]'s empirical study, there is a positive and significant association between South African university students and sustainability orientation. In a similar mode, among South Korean managers, OR can be achieved more successfully through the acquisition of knowledge, complex networking processes and entrepreneurial orientation [38].

Consequently, in the existing literature, EI is supported by Ajzen's TPB theory (attitudes, subjective norms and perceived behavioral control) and the Shapero–Krueger Model of the Entrepreneurial Event (EEM) (perceived desirability, feasibility and propensity to act) [39–41]. However, there are still gaps in the existing literature. First, EI is always supported by Ajzen's TPB [42,43] and the Shapero–Krueger Model of the Entrepreneurial Event (SEE) directly with all its predictors [33,44,45]. Second, most well-known scholars have not yet considered the presence of the OR factor integrated with TBP and EEM [14,43,46,47]. Third, the researcher did not find a previous study that focused on a theoretical framework that integrated EI through ATS, PED, PEF and OR to offer a new paradigm [42,43,48,49]. Fourth, in the main, Saudi Arabia has avoided the vital role of EI through ATS, PED, PEF and OR in the exploration of SEI [20,50,51]. Finally, no previous study has used a model that selected Saudi Arabian university students and the associated diversity factors, such as ATS, PED, PEF and SEI, that have a significant effect on OR, SEI, ATC, PED and PEF with respect to entrepreneurial orientation, the acquisition of knowledge, networking, sustainability orientation, self-efficacy, perceived usefulness, work environment, business opportunities, etc. [8,31,32,36,37,52].

To fill these gaps, the researcher devised a model (see Figure 1), which investigates OR and SEI through ATS, PED and PEF. They did not consider the other TPB factors since several scholars argued that, conceptually, perceived behavioral control and PEF are both associated with each other and measure a similar construct whereby an individual perceives their capability and has the necessary skills to start a business [14,46,53]. The researcher considered the ATS as it usually shaped the PED of the extent of an individual finding the idea of starting a business attractive, which may influence their attitude [14,54]. Moreover, ATS is a view from a single perspective that offers an evaluative judgment of an object in terms of its degree of goodness or badness [46,47]. Due to the above-mentioned reasons for substitutes and the different conceptual similarities, the researcher mixed the ATS, PED and PEF and expected the best prediction for OR and SEI. Moreover, we also developed the mediating role of OR between ATS, PED, PEF and SEI.

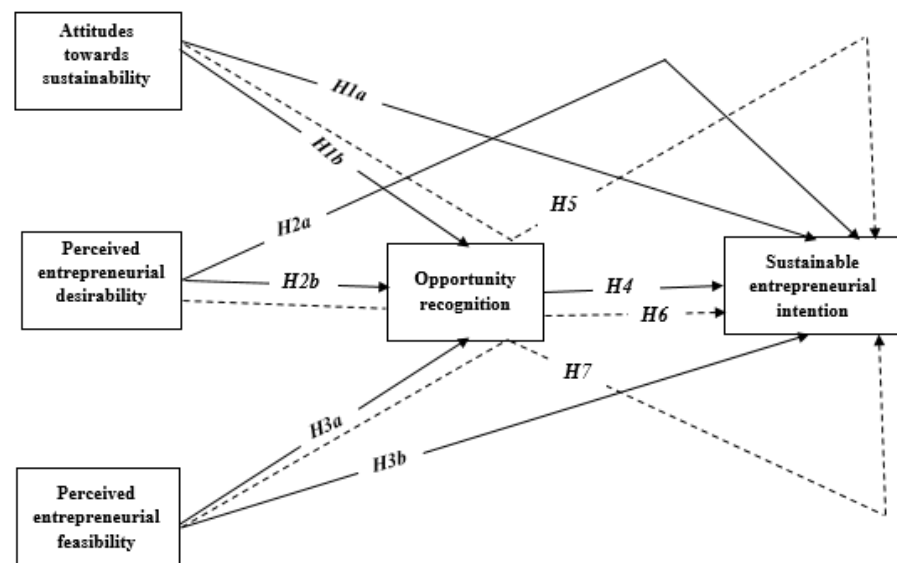

**Figure 1.** Conceptual model of the study. Source: Researcher's own conceptualization. Direct paths ———>. Indirect paths - - - - ->.

Investigating these factors ATS, PED, PEF, and OR is essential for environmental sustainability. Positive attitudes bring social awareness, environmental sustainability, profits, policies, environmental regulations, business management, reputation and leadership [4]. It also develops the willingness to protect sustainability, awareness and responsibility toward sustainable development [26]. It is also clear that individuals are deeply involved in the entrepreneurial process with great opportunity feasibility, desirability and beliefs [55,56]. Thus, environmental sustainability would be enhanced through the start-up process and market opportunities to speed up entrepreneurship [57]. It is also vital that ATS, PED, PEF and OR factors encourage entrepreneurs and students to be involved in business activities [58] through conducive and sustainable entrepreneurship that serves society meaningfully [38,59].

### 2.1. Attitudes towards Sustainability (ATS), Opportunity Recognition (OR) and Sustainable Entrepreneurial Intentions (SEI)

Entrepreneurship has a meaningful role in resolving employment problems and in promoting sustainable social and financial development with the support of sustainable entrepreneurship [60]. The sustainability culture, knowledge and practices greatly enhance the business's SEI. Entrepreneurial OR plays a successful role in mediating ATS' relationship with SEI [61]. The OR for sustainable development is an essential part of sustainable entrepreneurship. Sustainable entrepreneurs are affected in their identification of sustainable opportunities by entrepreneurial knowledge, and their motivations to improve gains

for themselves and others [60,62] suggest the positive effect of entrepreneurial alertness, entrepreneurial self-efficacy, proactive inclinations and creativity on OR and SEI.

An individual's ATS provides the significance of work values in tracking sustainability-oriented entrepreneurship so that postulants increase their knowledge podium and entrepreneurial skills, which inspire them to become in the future sustainable entrepreneurs [15,63] and reveal that ATS and PED boost orientations towards SEI. The students' sustainability-driven entrepreneurial intentions relate to ATS, PED and PED counterparts. Moreover, the promotion of sustainable opportunities leads to the development of potential sustainable entrepreneurship [64]. By applying TPB, a [2] meta-analysis claims that self-efficacy, ATS and subjective and perceived behavior control have significant and predictive powers on SEI. This study aims to also confirm the positive effects of environmental values on SEI, ATS, social norms and self-efficacy. Consequently, there is no confirmation of these relationships in Saudi Arabia combined, despite the students' robust determination to perform business activities with the incredible creativity and utilization of business-oriented skills and education they acquired from university [18]. They are ready to confront any entrepreneurial challenge without pressure and willing to bring sustainability to business [1,19]. Hence, the researcher formulated the following hypotheses:

**H1a.** *ATS has a positive and significant effect on enhancing SEI among university students in Saudi Arabia;*

**H1b.** *ATS has a positive and significant effect on enhancing OR among university students in Saudi Arabia.*

## *2.2. Perceived Entrepreneurial Desirability (PED), Opportunity Recognition (OR) and Sustainable Entrepreneurial Intentions (SEI)*

There are gender differences in PEF and PED since male students are more willing than female students to start their own businesses [65]. However, there are a few differences in terms of EI. The findings in [66,67] show that entrepreneurial cognitive patterns, entrepreneurial training, PEF and PED have significant predictive powers on EI. Similarly, attitudes toward sustainability are impacted by altruism, whereas intrinsic and extrinsic rewards determine PED. Sustainable entrepreneurial development enhances EI [15]. According to [65]'s study findings, there is a significant correlation between PED, PED and attitudes towards behavior and EI. On the other hand, there is a negative connection between PEF and PEF. Under the moderating effect of entrepreneurial passion, students' entrepreneurial mindsets, PED and FED significantly affect the SEI [68]. In a similar way, it is noteworthy that there is stronger desirability among Chinese university students and that undergraduate Pakistani students have stronger leanings toward EI. The quantitative findings in [69,70] underline that PEF and PED have a positive and significant influence on the development of EI among undergraduate students.

In the market, entrepreneurs contrarily form opportunity feasibility, desirability and beliefs to judge the opportunities. OR indicates that individuals are deeply involved in the entrepreneurial process [55]. An active OR better appraises opportunity feasibility, desirability and beliefs [56]. OR is sufficient to advance through the start-up process and provide market opportunities to speed up entrepreneurship [57]. Based on the existing positive relationships, the researcher formulated the following hypotheses:

**H2a.** *PED has a positive and significant effect on enhancing SEI among university students in Saudi Arabia;*

**H2b.** *PED has a positive and significant effect on enhancing OR among university students in Saudi Arabia.*

### 2.3. Perceived Entrepreneurial Feasibility (PEF), Opportunity Recognition (OR) and Sustainable Entrepreneurial Intentions (SEI)

For budding entrepreneurs, it is necessary to recognize the opportunities provided by the entrepreneurial process and to create a business. Therefore, it is important to believe in beliefs identifying opportunities that facilitate new businesses in an emergent economy [71]. Entrepreneurs' OR is the individual's judgment to start a business [56]. PEF focuses on the instant needs of starting a new business that can be successful in achieving a sustainable organization. This success is contingent on the new business' capacity to underscore its exclusivity and its capacity to fit into its external environment [72].

Individuals try to identify entrepreneurial opportunities to start their own businesses. Entrepreneurial education has proven to be a significant pillar between it and entrepreneurial OR. This leads to better EI [73]. By using EEM among business students, the findings of [33]'s empirical study demonstrate that PEF, PED and self-efficacy have a positive and significant influence on SEI. Similarly, the findings of [74]'s investigation support the claim that PEF and PED have a considerable impact on EI. In contrast, this study's findings did not endorse the positive connection between self-efficacy and EI. Among sports students, there is a positive association between PEF, PED and self-efficacy and EI [75]. In Bangladesh, subjective norms and attitudes are the significant enablers of PED and perceived behavioral control is an enabler of PEF. Ultimately these all predict EI [76].

With respect to budding entrepreneurs, PED, PEF, subjective norms and entrepreneurial attitudes significantly improve students' intentions to become entrepreneurs. Remarkably, the student's existing capability and skills do not prove to be a momentous forecaster of their intentions to become entrepreneurs [77]. According to [78], PED, entrepreneurial self-efficacy and PEF are the full mediators between attention deficit hyperactive disorder and EI.

Even among Norwegian women entrepreneurs, the EEM mode is constructive in considering the business and the environment. More specifically, PEF and PED are the factors that encourage women to commence business activities [58]. Consequently, the existing literature demonstrates the positive associations between PEF, SEI and OR. Therefore, the researcher formulated the following hypotheses:

**H3a.** *PEF has a positive and significant effect on enhancing SEI among university students in Saudi Arabia;*

**H3b.** *PEF has a positive and significant effect on enhancing OR among university students in Saudi Arabia.*

### 2.4. Opportunity Recognition (OR) and Sustainable Entrepreneurial Intentions (SEI)

Entrepreneurial opportunity is fundamental to instigating entrepreneurship [38,59]. The role of entrepreneurial opportunities is a crucial area of concern for entrepreneurship research, and, in this regard, scholars have recognized that OR is a critical issue. The primary reason is that the development of entrepreneurship begins in OR. Moreover, entrepreneurship practice is a sequence of recognizing and grasping opportunities in terms of entrepreneurship processes. In the TPB, EI is the best predictor of entrepreneurial behavior. Ref. [38]'s findings show that OR mediates the relationship between the social network and EI. Therefore, OR may have a constructive influence on EI. By focusing on the same aspects, [79]'s findings demonstrate that, among Indian university students, OR and self-efficacy have a positive and predictive effect on EI. According to [80], rather than fear of failure, entrepreneurial knowledge, role models and opportunity discovery have positive and significant effects on female EI. Similarly, [81]'s conceptualization shows mindfulness' meaningful relationship with OR, ethical decision-making and evaluation. On the other hand, among Kuwaiti nationals, accessibility of resources and OR are not found to be significant analysts of EI. On the other hand, there is a substantial correlation between other factors, such as self-efficacy, need for achievement, social networking and risk tolerance,

and EI [82]. Sustainable entrepreneurs have demonstrated their identity of sustainable opportunities through their knowledge of natural and communal environments [62]. In Taiwanese franchises, the successive propensity to the franchise is moderated by the franchisors' entrepreneurial OR and cooperation flexibility [83].

In a similar sphere, [84] posit a positive association between capability and social insight to become a sustainable entrepreneur. Moreover, OR plays no role in developing the association between social perceptions and intentions Ref. [17]'s. SEM analysis shows that the acquisition of knowledge of entrepreneurship knowledge acquisition, OR and entrepreneurship education have significant effects on EI and entrepreneurial self-efficacy. Likewise, in the green dimension, OR is also a significant direct and indirect predictor of students' green EI through entrepreneurship education [85]. Consequently, based on the existing literature's support of positive associations, the researcher formulated the following hypothesis:

**H4.** *OR has a positive and significant effect on enhancing SEI among university students in Saudi Arabia.*

#### *2.5. Opportunity Recognition (OR) as a Mediator*

Entrepreneurship provides several business opportunities for individuals to achieve a better quality of life. Nevertheless, the business's crucial part is recognizing the business opportunity. OR factor enables individuals to remember a good idea and transform it into a business concept. According to [86], attitudes toward start-ups and money significantly influence EI. OR mediates the relationship (between attitude toward start-up and EI). OR successfully mediates the association between environmental sustainability, sustainability culture and commitment and SEI [61]. Among Indian universities, OR and entrepreneurial education, directly and indirectly, influence EI, self-efficacy and entrepreneurial attitude [87]. The empirical evidence in [88] demonstrates entrepreneurial intention as the positive and negative mediator between OR and external locus of control. [89] recognize the relationship between PED, PEF and EI. In Iranian universities, students' identification of opportunities and EI is positively associated [90]. In a similar domain, [91] demonstrates a partial mediating effect of prior knowledge and OR in developing the relationship between entrepreneurial alertness and EI. According to [15], SEI is driven by attitudes toward sustainability, PED and PEF, and these relationships are possible through the indirect effects of OR.

Consequently, the clear literature cult shows the mediating effect of OR in developing the association of ATS, PED and PEF SEI. However, among university students in Saudi Arabia, it needs further validation. Thus, we proposed:

**H5.** *OR positively and significantly mediates the relationship between ATS and SEI among university students in Saudi Arabia;*

**H6.** *OR positively and significantly mediates the relationship between PED and SEI among university students in Saudi Arabia;*

**H7.** *OR positively and significantly mediates the relationship between PEF and SEI among university students in Saudi Arabia.*

### **3. Methods**

#### *3.1. Selection of Approach*

This study's objective is to investigate the development of entrepreneurial sustainability among Saudi Arabian university students. Therefore, the study is concerned with the individuals' attitudes and behavioral responses. This approach ensures the respondents' confidentiality and integrity and is also practicable to the researcher in saving resources and time [92]. Moreover, by using a five-point Likert scale, which has satisfactory reliability and validity, this type of investigation provides the respondents with a wide range of options [93]. In considering this assumption, the researcher decided to conduct a quantitative

research study due to its presentation of valuable insights into reality and there being little chance of bias [94].

Relatively, this quantitative method is meaningfully supported by the domain researcher such as [8,13,31,36,37] since, by using several predictors and criterion variables, they adopted the same methods to evaluate the SEI, OR, ATC, PEF and PED also.

### 3.2. Respondents and Data Collection

The researcher targeted known Saudi Arabian university students as potential entrepreneurs [18]. They selected the different Saudi Arabian public sector universities on a random basis. They targeted the university students as the study respondents because they were developing their creativity and skills to become efficacious in business. They “lead entrepreneurship with innovation means to create more employment opportunities through entrepreneurship and to promote college and university graduates to have higher quality entrepreneurship and employment” [1]. These potential entrepreneurs were involved in bringing in social sustainable entrepreneurial development [19] and were ambitious to commence their businesses on completion of their studies. Therefore, the researcher identified all the sustainable entrepreneurs. Initially, they contacted the departmental heads/chairman/directors to obtain consent to distribute the questionnaires. Then, they obtained assistance from the teachers to distribute them.

The researcher mainly targeted MIS, management, accounting, finance and business students who were aware of entrepreneurship/business. Before distributing the questionnaires, the researcher explained this study’s aim and objectives. The researcher also obtained the respondents’ consent to participate in this study. Initially, the researcher distributed about 600 questionnaires through personal visits. In return, they received 296 raw samples, with a 49% response rate. After cleaning and screening the data, they processed 292 valid cases for further analysis.

To consider the required sample size, the researcher applied G\*Power (version 3), an outstanding freeware program with high-precision power [95]. This statistical software package is best for calculating statistical power for sample size analysis for behavioral research’s most common statistical tests [96,97]. The researcher applied four main predictors to confirm an adequate sample size. The G\* power suggested that 129 samples were required to perform SEM analysis. Finally, the researcher utilized 292 valid samples, which fulfilled the G\* power and SEM’s criteria for analysis.

### 3.3. Scale Confirmation

This study used cross-sectional data. The researcher took appropriate steps to conduct the research study. Using the relevant literature, they adapted all the scale items. The researcher conducted the pilot study (small study) to confirm research protocols, data collection instruments and sample recruitment strategies prior to conducting a large-scale study [98]. A pilot study has great importance and is an important stage in a research project to identify deficiencies and potential problems in the research questionnaire (instrument) prior to implementation during the full-scale study [99]. The main purpose of piloting was to assure the reliability and validity assumption of the survey questionnaire before acquiring much more data [98,100]. In this way, the researcher obtained the response from 38 respondents to establish the validity and reliability of the scale. They assured the internal consistency among the items using Cronbach’s alpha ( $\alpha$ ) reliability [101]. The internal consistency proved to be excellent since it appeared overall as 0.756, while individual factors had acceptable reliability ( $>0.60$ ) [102]. Turning to validity, the researcher verified the questionnaire with two university professors who were experts in the field of entrepreneurship and management sciences. As regards validity, the experts appreciated the design, structure, and relevance of the items to this study’s research objectives. Therefore, the researcher made minimal changes to the questionnaire to reflect the experts’ opinions. Further, they also observed the respondents’ easiness in completing the question-



naire. Consequently, after confirming reliability and validity assumptions, the researcher distributed the questionnaire to collect large-scale data.

### 3.4. Measures

#### 3.4.1. Attitudes towards Sustainability (ATC)

The researcher measured ATC by using six items adapted from [103,104]. Based on time and resources, these items cover social and environmental issues (see Appendix A) to evaluate entrepreneurial opportunities.

#### 3.4.2. Perceived Entrepreneurial Desirability (PED)

The researcher measured PED on five items adapted from [105]'s study. The sample item is: "Being an entrepreneur implies more advantages than disadvantages to me."

#### 3.4.3. Perceived Entrepreneurial Feasibility (PEF)

The researcher measured PEF on five items adapted from [53,106]. The sample item is: "I am sure of myself that I would start your own business."

#### 3.4.4. Opportunity Recognition (OR)

The researcher measured OR on five items adapted from [107]. The sample item is: "The entrepreneurial opportunities I identified are very unique."

#### 3.4.5. Sustainable Entrepreneurial Intentions (SEI)

The researcher evaluated SEI based on five items adapted from the [108]'s study. The sample item is "I think I will choose to start a business focusing more on social or environmental problems primarily as new business opportunities in the future."

The researcher used a five-point Likert scale, ranging from strongly agree to strongly disagree, to measure all the scale items. Appendix A details the complete questionnaire.

## 4. Data Analysis and Outcomes

### 4.1. Respondents' Profiles

In total, 296 respondents contributed to this study. The data show 64.86% ( $n = 192$ ) were male and 35.14% were female ( $n = 104$ ). Turning the students' discipline of the students, the largest number of students (27.03% or  $n = 80$ ) were in business administration, 26.35% ( $n = 78$ ) were in management, 22.30% ( $n = 66$ ) were in accounting, 12.50% ( $n = 37$ ) were in MIS and only 11.82% ( $n = 35$ ) students were studying finance. It is noteworthy that 89.86 ( $n = 266$ ) of the respondents were interested in starting a business and only 10.14 ( $n = 30$ ) were not. Moreover, 65.54 ( $n = 194$ ) of the students' families were involved in business, and 34.46% ( $n = 102$ ) did not wish for their students to have their own businesses or be involved in family businesses. Turning to family income, the data show that 58.79% ( $n = 174$ ) of students' family incomes were more than SR 10,000, and 27.70% ( $n = 82$ ) had an income higher than SR 5000 and less than SR 10,000. Finally, the researcher noted that only 13.51% ( $n = 40$ ) of students had a family income of less than 5000 SR (see Table 1).

### 4.2. Descriptive Statistics and Correlations

The researcher conducted descriptive statistics to observe the midpoint of a spread of scores; this is frequently referred to as the measure of central tendency [109]. Before looking explicitly at descriptive statistics, the researcher observed that the mean scores ranged from 3.582(PED) to 3.879 (SEI), while the ranges of standard deviation were from 1.009 (SEI) to 1.787 (PED). Furthermore, the researcher calculated the Pearson correlation coefficient to measure the strength of linear association among the constructs [110]. Consequently, all the constructs appeared to correlate strongly with two asterisks; this ensured a strong correlation (see Table 2).

**Table 1.** Respondents' profiles.

	Category	Frequency	%
Gender	Male	192	64.86
	Female	104	35.14
	Total	296	100.0
Program	MIS	37	12.50
	Management	78	26.35
	Accounting	66	22.30
	Finance	35	11.82
	Business	80	27.03
	Total	296	100.0
Interest in venture creation	Yes	266	89.86
	No	30	10.14
	Total	296	100.0
Family business	Yes	194	65.54
	No	102	34.46
	Total	296	100.0
Family income	<5000 SR	40	13.51
	>5000 SR and <10,000 SR	82	27.70
	>10,000 SR	174	58.79
	Total	296	100.0

**Table 2.** Descriptive Statistics and Correlation Matrix.

S.No.	Constructs	Mean	Std. Deviation	1	2	3	4	5
1	SEI	3.879	1.009	—				
2	ATS	3.773	1.187	0.382 **	—			
3	PED	3.582	1.787	0.392 **	0.117 *	—		
4	PEF	3.630	1.728	0.402 **	0.492 **	0.456 **	—	
5	OR	3.721	1.123	0.320 **	0.333 **	0.303 **	0.341 **	—

\*\* . Correlation is significant at the 0.01 level (2-tailed). \* . Correlation is significant at the 0.05 level (2-tailed). Note(s): SEI = sustainable entrepreneurial intention; ATS = attitudes towards sustainability; PED = perceived entrepreneurial desirability; PEF = perceived entrepreneurial feasibility; OR = opportunity recognition.

#### 4.3. Measurement Model

To examine the arrangement of the measurement items and their connection to the individual factors in the conceptual framework [111], the researcher employed a better solution to assess the validity of the statistical facts' [112]. More importantly, the examination of many latent constructs through SEM reduces errors in the model [102]. The researcher explored the measurement model to gauge the associations between latent constructs and their measures. The first stage followed the recommendations of renowned scholars, such as [113], by testing the validity through measurement models. In factor loadings, the researcher noted the correlations and consistency among the items and their factors [113] within the limit of loadings from 0.703 (sei4) to 0.897 (or 1). These values qualified the suggested scores of factor loadings above 0.70. This demonstrates the present statistical significance and determines high convergence on a common point [113]. On the other hand, two items, namely, ats3 and or2, did not appear with the above-recommended values, i.e., 0.70, and, therefore, the researcher decided to exclude them from further analysis. Moreover, the Composite Reliability (CR) values were reliable since the CR appeared to be between 0.786 (PEF) to 0.884 (ATS). These highlighted the excellent internal consistency among the constructs; this is above recommended values (>0.70) [114]. Moreover, to ensure the items' reliability through the Average Variance Extracted (AVE), this study's findings show AVE values between 0.798 (OR) to 0.896 (ATS); these are higher than 0.50 and indicate an adequate convergence [113]. Lastly, Cronbach's alpha (internal consistency) of all the constructs has been detected as satisfactory (>0.70) [115]. It remained 0.792–0.890 (>0.70), and this ensured high or acceptable reliability for model validation (see Table 3).

**Table 3.** Measurement Model.

Factors	Item Code	Loading Score	CR	AVE	Cronbach's Alpha ( $\alpha$ ) Reliability
Attitudes towards sustainability (ATS)	ats1	0.887	0.884	0.896	0.890
	ats2	0.863			
	ats4	0.851			
	ats6	0.832			
	ats5	0.821			
Perceived entrepreneurial desirability (PED)	ped1	0.831	0.832	0.863	0.853
	ped 2	0.822			
	ped4	0.818			
	ped3	0.800			
	ped5	0.782			
Perceived entrepreneurial feasibility (PEF)	pef1	0.862	0.786	0.806	0.889
	pef 2	0.842			
	pef 3	0.833			
	pef4	0.821			
	pef5	0.811			
Opportunity recognition (OR)	or1	0.897	0.879	0.798	0.826
	or3	0.871			
	or5	0.852			
	or4	0.821			
Sustainable entrepreneurial intention (SEI)	sei1	0.829	0.880	0.812	0.792
	sei 2	0.802			
	sei 3	0.759			
	sei5	0.712			
	sei4	0.703			

Note(s): CR= Composite reliability; AVE = Average variance extracted;  $\alpha$  = Cronbach's alpha.

#### 4.4. Structural Model

The researcher applied Analysis of Moment Structures (AMOS) IBM version 26.0 to interpret the results. We preferred AMOS over PLS since AMOS is a package to estimate factor-based models and conduct confirmatory research and is the best choice to test the theory [54]. Moreover, AMOS provides new insights from data by testing hypotheses of complex variable relationships [116]. On the other hand, PLS has the advantage of not putting a constraint on a normal distribution even if there is a small sample, and there is no constraint on the normal distribution of the sample distribution through PLS [117].

The researcher applied CB-SEM (AMOS since it was used frequently through AMOS) to test the association and because the objectives of this study were also to observe the model fitness [54,118]. The researcher did not apply PLS-SEM because it was appropriate in the exploratory stage for theory building and forecasting [119–121]. The results of the goodness-of-fit indices (see the caption in Figure 2) favored the fitness of the data. However, by employing the critical ratio, the results accepted the effect of ATS on SEI and OR ( $H1a = 4.291^{***}$ ;  $H1b = 5.184^{***}$ ;  $p < 0.01$ ) (see Table 4 and Figure 2). Therefore, hypotheses H1a and H1b are accepted. The results confirmed that PED has a positive and significant effect on SEI and OR ( $H2a = 5.901^{***}$ ;  $H2b = 6.661^{***}$ ;  $p < 0.01$ ) (see Table 4 Figure 2). Therefore, hypotheses H2a and H2b are accepted. Similarly, PEF has a positive and significant effect on OR and SEI ( $H3a = 5.909^{***}$ ;  $H3b = 6.675^{***}$ ;  $p < 0.01$ ) (see Table 4 and Figure 2). Therefore, hypotheses H3a and H3b are accepted. Finally, the SEM analysis indicates that OR has a positive and predictive power on SEI ( $H4 = 4.437^{***}$ ;  $p < 0.01$ ) (see Table 4 and Figure 2). Therefore, hypothesis H4 is accepted.

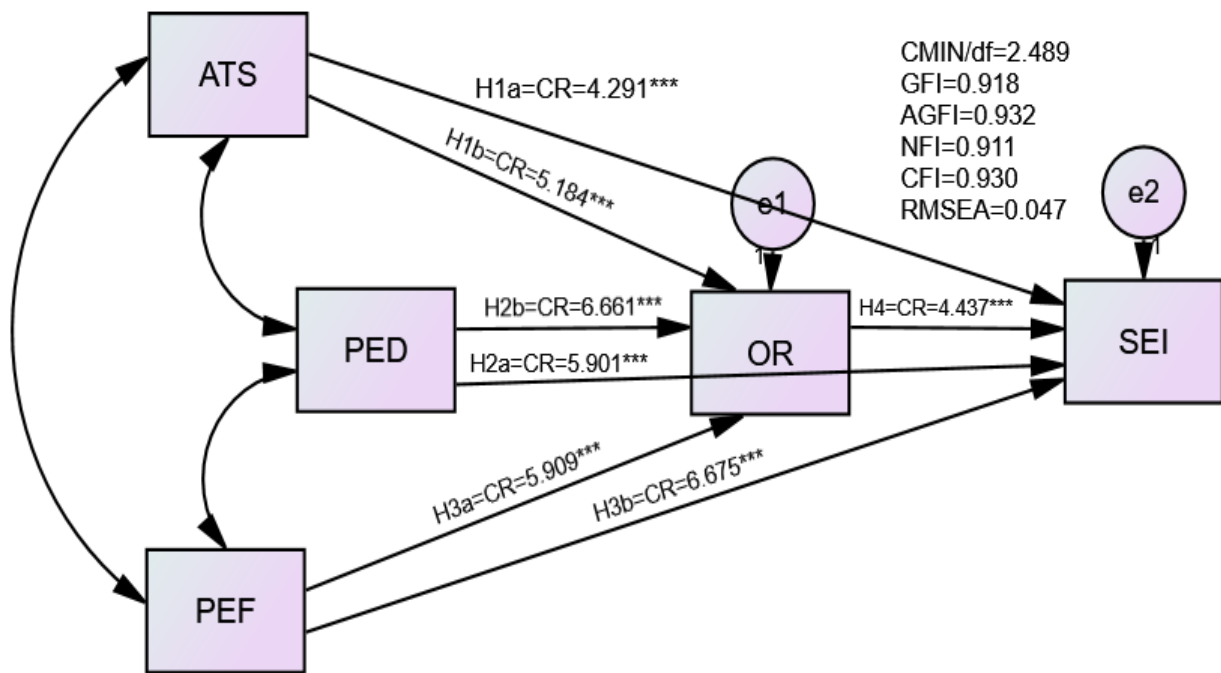

**Figure 2. Path Analysis (direct paths)** Source: Author’s own estimation. Note: CR = critical ratio; *p* \*\*\* = significance level at <0.01. SEI = sustainable entrepreneurial intention; ATS = attitudes towards sustainability; PED = perceived entrepreneurial desirability; PEF = perceived entrepreneurial feasibility; OR = opportunity recognition.

**Table 4. SEM Estimations [direct paths].**

S.No.	Independent Variables	Path	Dependent Variables	CR	<i>p</i> -Value
H1a	ATS	→	SEI	4.291	***
H1b	ATS	→	OR	5.184	***
H2a	PED	→	SEI	5.901	***
H2b	PED	→	OR	6.661	***
H3a	PEF	→	OR	5.909	***
H3b	PEF	→	SEI	6.675	***
H4	OR	→	SEI	4.437	***

Note: CR = critical ratio; *p* \*\*\* = significance level at <0.01. SEI = sustainable entrepreneurial intention; ATS = attitudes towards sustainability; PED = perceived entrepreneurial desirability; PEF = perceived entrepreneurial feasibility; OR = opportunity recognition.

Concerning indirect effects, we found a significant positive role of OR in developing the relationship of ATS, PED and PEF with SEI (H5 = 3.634 \*\*\*; H6 = 4.222 \*\*\*; H7 = 5.452 \*\*\*; *p* < 0.01) (see Table 5 and Figure 3). As a result, H5, H6 and H7 are accepted. Table 6 details the confirmation of the hypotheses.

**Table 5. SEM estimations (Indirect paths).**

S.No.	Independent Variables	Path	Mediator	Path	Dependent Variables	CR	<i>p</i> -Value
H5	ATS	→	OR	→	SEI	3.634	***
H6	PED	→	OR	→	SEI	4.222	***
H7	PEF	→	OR	→	SEI	5.452	***

Note: CR = critical ratio; *p* \*\*\* = significance level at <0.01. SEI = sustainable entrepreneurial intention; ATS = attitudes towards sustainability; PED = perceived entrepreneurial desirability; PEF = perceived entrepreneurial feasibility; OR = opportunity recognition.

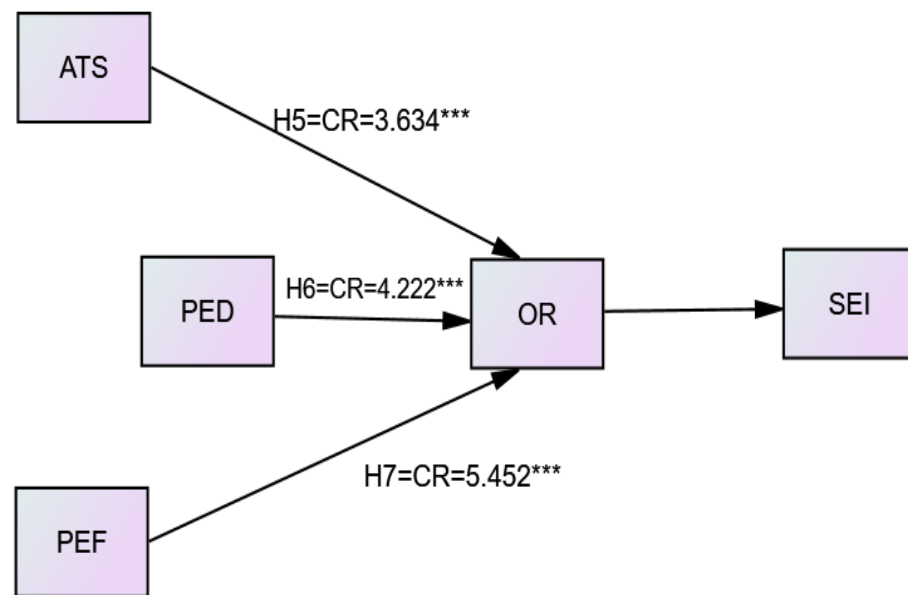

**Figure 3. Path Analysis (indirect paths).** Source: Author’s own estimation. Note: CR = critical ratio;  $p^{***}$  = significance level at  $<0.01$ . SEI = sustainable entrepreneurial intention; ATS = attitudes towards sustainability; PED = perceived entrepreneurial desirability; PEF = perceived entrepreneurial feasibility; OR = opportunity recognition.

**Table 6.** Summary of Confirmation of the Hypotheses.

No.	Hypotheses Description	Decision
H1a	ATS positively and significantly enhances SEI among university students in Saudi Arabia.	Accepted
H1b	ATS positively and significantly enhances OR among university students in Saudi Arabia.	Accepted
H2a	PED positively and significantly enhances SEI among university students in Saudi Arabia.	Accepted
H2b	PED positively and significantly enhances OR among university students in Saudi Arabia.	Accepted
H3a	PEF positively and significantly enhances SEI among university students in Saudi Arabia	Accepted
H3b	PEF positively and significantly enhances OR among university students in Saudi Arabia.	Accepted
H4	OR positively and significantly enhances SEI among university students in Saudi Arabia.	Accepted
H5	OR positively and significantly mediates the relationship between ATS and SEI among university students in Saudi Arabia.	Accepted
H6	OR positively and significantly mediates the relationship between PED and SEI among university students in Saudi Arabia.	Accepted
H7	OR positively and significantly mediates the relationship between PEF and SEI among university students in Saudi Arabia.	Accepted

## 5. Discussion

In this study, the researcher investigated among Saudi Arabian university students SEI through ATS, PED, PEF and OR. The study also confirmed the mediating role of OR in developing the association of ATS, PED and PEF with SEI. For this purpose, they developed a conceptual framework and model. They formulated the assumptions in the hypotheses based on the relevant existing literature. The data collection strategy involved

a questionnaire about which the researcher initially sought expert opinion concerning its validity and reliability. Hypotheses H1a and H1b, which are accepted, demonstrate that ATS has a positive and significant effect on SEI and OR. These findings, which indicate ATS' predictive role in respect of SEI and OR, are consistent with the findings of previous studies by several scholars such as [15,60–63]. These positive findings reflect that the students are anxious about commencing their own businesses if they are not provided with the required resources and time. From a sustainable social perspective, they want to reduce poverty by starting their own businesses. They are willing to create employment and self-employment and want to make use of the business initiatives and, in doing so, allocate the resources on an equality and social justice basis. Most importantly, through their businesses consuming low energy and making the best use of other resources, they want to reduce the hazardous impacts on the environment.

Furthermore, this study's findings confirm that, with the acceptance of hypotheses H2a and H2b, PED has a positive and significant influence on SEI and OR. These positive relationships are supported by several studies, such as [15,65–69]. Their findings demonstrate in several contexts that PED has a positive effect on SEI and OR. The positive associations indicate that Saudi Arabian university students realize the advantages of becoming entrepreneurs. They wish to choose entrepreneurship as their career option. In other words, entrepreneurship attracts them due to the creation of several business opportunities. They think they would like to start their own business firm if they had the opportunities and resources to do so. They are comfortable with entrepreneurship.

Similarly, this study's findings also show that, in accepting hypotheses H3a and H3b, there is a positive and significant relationship between PEF and SEI and between PEF and OR. These findings are consistent with those of previous studies by [33,56,71,72]. On the other hand, 55's findings do not support these findings. However, the positive trends of this study's findings show that entrepreneurs are confident in starting their own businesses. They also think if they start their own business, they will be overworked but sure to be successful. Finally, they try to acquire sufficient knowledge to start their own businesses.

The hypothesis, H4, is accepted by demonstrating OR's significant effect on SEI. Likewise, this finding is consistent with those of previous studies by [17,62,82–85]. These findings reflect that they want to identify unique entrepreneurial opportunities and to produce either sustainable products or services that are socially recognized and acceptable. They wish to provide products or services that are not widely available in the market. They want to make the best use of entrepreneurial opportunities to offer services that can lead to greater social benefits. They can provide more sustainable development and are eager to start businesses that are better at dealing with current and future social or environmental problems. They wish to overcome practical difficulties and take care of society's social, ecological and economic issues. By comparison, they are willing to start a sustainable and innovative business rather than seek employment. Finally, they have the possibility of creating social entrepreneurship in the next five years.

Finally, the study showed a positive significant mediating effect of OR in developing the relationship of ATS, PED and PEF with SEI (H5, H6 and H7 are accepted). These outcomes are reinforced by various scholars who found a mediating effect of OR with EI and SEI in different contexts [15,61,86,90]. OR has a crucial reputation in the business, enabling individuals to transform ideas into start-ups and money. These initiatives enhance EI among university students in Saudi Arabia. Furthermore, the mediating effect of OR suggests substantial factors such as ATS, PED and PEF, which consequently promote the SEI or drive the attitudes toward sustainability, PED and PEF towards SEI [15].

## 6. Implications/Contributions

### 6.1. Practical Contribution

This study's findings show a positive and significant association between ATS, PED, PEF, OR and SEI among Saudi Arabian university students. In practice, this assumption provides tremendous practical significance to refining university students' SEI and

stimulating sustainable development of economic, social, and environmental protection. Sustainable entrepreneurship is a new and innovative form of entrepreneurship. The Saudi Arabian Government departments may emphasize sustainable entrepreneurship to resolve problems relating to the environment, economy and entrepreneurship. This study's findings are helpful for concerned authorities in endorsing policies to inspire and guide university students to establish sustainable businesses. The Saudi Arabian Government would determine, foster, and support sustainable entrepreneurs by promoting sustainable entrepreneurship education and training to develop the entrepreneurs to have upbeat psychologies and healthy personalities.

This study's findings provide novel contributions to the literature, which adds an integrated model (ATS, PED, PEF, OR and SEI). This model/ study would allow readers to know how to overcome employment problems by enhancing sustainable social and business development with sustainable entrepreneurship. This study's findings also highlight sustainability in culture, knowledge and practices, which are massively responsible for either boosting the business or the SEI. Sustainable entrepreneurs help use their entrepreneurial knowledge to identify sustainable opportunities from which they can profit. Students' positive and sustainable brashness offers value and significance to pursuing sustainability-oriented entrepreneurship and enables them to improve their skills and knowledge and nurture future entrepreneurs. This study's findings are supportive in judging the opportunities for ambitious entrepreneurs who wish to involve themselves fully in the entrepreneurial and start-up processes. For nascent entrepreneurs, these findings are hopefully valuable in their recognizing the indispensable opportunities to create new businesses and entrepreneurial development in the economy. By accomplishing these goals, the entrepreneurs advance sustainability and accentuate the benefits to the environment. The students' positive inclinations to recognize sustainable opportunities, along with the support of knowledge of natural and communal environments, further develops their competencies and social insights to become more sustainable and successful entrepreneurs.

### *6.2. Theoretical Contribution*

This study's findings provide several theoretical implications in the context of Saudi Arabia. In this study, the researcher has investigated the direct effects of OR, ATS, PEF and PED on SEI. These relationships may fill the gap in previous studies that did not offer these constructs in a single model. This study's theoretical contribution demonstrates the significant roles played by ATS, PED and PEF towards OR and SEI. The study confirmed the mediating effect of OR in developing the relationship between ATS, PED, PEF and SEI. These conformations further enrich the theoretical base of TBP theory and EEM, which are integrated into the model. This study's findings make an academic contribution by examining the formation of entrepreneurial sustainability through ATS, PED, PEF and OR and indirectly through OR by addressing calls to understand among Saudi Arabian university students how the development of SEI is possible through the ATS factor of TBP and PED and FED factors of the EEM model. This study's findings have made a significant theoretical contribution by adding OR with SEI directly and indirectly in the presence of ATS, PED and PEF. The addition of OR (directly and indirectly) offers theoretical insights by demonstrating how to acquire a new understanding of the phenomena by reorganizing causal maps. These findings assist in explaining the SEI mechanism and provide empirical confirmation from Saudi Arabian university students who are ambitious, enthusiastic and inclined to avail themselves of the opportunities to create sustainable businesses. Finally, this study's findings may help to generate other theories.

## **7. Conclusions**

In conclusion, this study's overall findings show that, among Saudi Arabian university students, ATS, PED and PEF have positive and significant effects on SEI and OR. Moreover, OR is the positive and significant mediator that developed the positive association between ATS, PED, PEF and SEI. The students are enthusiastic and ambitious and have strong

attitudes toward sustainability. Moreover, the findings also confirm the positive association between OR and SEI.

This study's findings are based on the combination of various theory-based constructs, such as ATS, PED and PEF, towards SEI and the mediating contribution of OR. These findings fill the gaps in the previous studies that did not empirically confirm in an integrated way the relationships between ATS, PED, PEF and OR (directly and indirectly) and SEI. Methodologically, this study's findings bring new observations and paradigms and, through empirical confirmation, set the stage for new knowledge. The originality of this study 'is presenting a new model using two existing theories, and the provision of support of another construct also shows the uniqueness of the Saudi Arabian university students. Moreover, these scenarios may also help to develop other new novel ideas.

The results of the study can be generalized to the Cooperation Council for the Arab States of the Gulf (the Gulf Cooperation Council), where there may be a similar environment of the university where students have positive attitudes, trends, desirability and feasibility encourage them to participate in SEI. They may sort the OR to contribute to the entrepreneurial environment and sustainable development to bring positive social change.

This study has some limitations. First, the study employed cross-sectional data for the SEI, ATS, PED, PEF and OR. These variables are attitudes and behavioral changes from time to time and from environment to environment. Therefore, this study does not fully reflect the dynamics of the data that have influenced the findings. This is because the researcher investigated limited constructs, such as PED, PEF and ATS, and their effects on OR and SEI. Moreover, only OR is observed as the mediator. Finally, this study consisted of only 292 samples. This number does not represent the whole population of Saudi Arabian university students; therefore, the findings cannot be generalized.

In future research studies, the researcher recommends that more comprehensive and satisfactory samples might be applied to ensure the generalization of the findings through an adequate representation of the population. The researcher recommends that a time series or longitudinal data be employed to increase the reliability of the findings. In addition, future studies may include other factors, such as personal control, self-esteem, self-efficacy, subjective norms, need for achievement and innovations by integrating the SEI.

**Author Contributions:** Conceptualization, N.A.A.A.; methodology, N.A.A.A.; software, N.A.A.A.; validation, N.A.A.A.; formal analysis, N.A.A.A.; investigation, N.A.A.A.; resources, N.A.A.A.; data curation, N.A.A.A.; writing—original draft preparation, N.A.A.A.; writing—review and editing, N.A.A.A.; visualization, N.A.A.A.; supervision, N.A.A.A.; project administration, N.A.A.A.; funding acquisition, N.A.A.A. All authors have read and agreed to the published version of the manuscript.

**Funding:** This work was supported by the Deanship of Scientific Research, Vice Presidency for Graduate Studies and Scientific Research, King Faisal University, Saudi Arabia (Project No. GRANT1419).

**Institutional Review Board Statement:** This study was conducted according to the guidelines of the Declaration of Helsinki and approved by the deanship of the scientific research ethical committee, King Faisal University (project number: GRANT1419, the date of approval was 18 August 2022).

**Informed Consent Statement:** The author obtained informed consent from all subjects involved in this study.

**Data Availability Statement:** Data are available upon request from the researcher to those who meet the eligibility criteria. Please kindly contact the first author privately through e-mail.

**Conflicts of Interest:** The author declares no conflict of interest.



## Appendix A

Factor	Item Description	Source
Attitudes towards sustainability [ATS]	<p>If I had the required time and resources, I would consider the issues when evaluating the entrepreneurial opportunity:</p> <p><i>Social impacts at the ventures:</i></p> <ol style="list-style-type: none"> <li>Poverty reduction</li> <li>Employment</li> <li>Increasing equality</li> </ol> <p><i>Environmental impacts at the venture:</i></p> <ol style="list-style-type: none"> <li>Use of natural resources</li> <li>Protecting biodiversity</li> <li>Energy type.</li> </ol>	[103,104]
Perceived entrepreneurial desirability [PED]	<ol style="list-style-type: none"> <li>Being an entrepreneur implies more advantages than disadvantages to me.</li> <li>A career as an entrepreneur is attractive to me.</li> <li>If I had the opportunity and resources, I would like to start a firm.</li> <li>Being an entrepreneur would entail great satisfaction for me.</li> <li>Among various options, I would rather be an entrepreneur.</li> </ol>	[105]
Perceived entrepreneurial feasibility [PEF]	<ol style="list-style-type: none"> <li>I am sure that I would start my own business.</li> <li>I think it will be easy to start my own business.</li> <li>If I started my own business, I would be overworked.</li> <li>If I started my own business, I would be sure of success.</li> <li>I try to know enough to start my own business.</li> </ol>	[53,106]
Opportunity recognition [OR]	<ol style="list-style-type: none"> <li>The entrepreneurial opportunities I identified are very unique.</li> <li>The sustainable products or services I have identified as sustainable entrepreneurial opportunities can be recognized socially.</li> <li>The products or services I have identified are not widely available in the market.</li> <li>The sustainable product or service offered by an entrepreneurial opportunity can lead to higher social benefits.</li> <li>A sustainable product or service provided by an entrepreneurial opportunity can provide more sustainable development.</li> </ol>	[107]
Sustainable entrepreneurial intention [SEI]	<ol style="list-style-type: none"> <li>I think I will choose to start a business focusing more on social or environmental problems primarily as new business opportunities in the future.</li> <li>If I have the opportunity and the freedom to decide, I will choose to start a business that contributes to social, ecological and economic developments in our society</li> <li>I will still choose to start my own business on eco-products when I encounter practical difficulties.</li> <li>Compared to having a stable job, I am more willing to start a business with sustainable innovations.</li> <li>I think I have the possibility of starting social entrepreneurship in the next five years.</li> </ol>	[108]

## References

1. Yan, X.; Gu, D.; Liang, C.; Zhao, S.; Lu, W. Fostering Sustainable Entrepreneurs: Evidence from China College Students' "Internet Plus" Innovation and Entrepreneurship Competition (CSIPC). *Sustainability* **2018**, *10*, 3335. [\[CrossRef\]](#)
2. Peng, H.; Li, B.; Zhou, C.; Sadowski, B.M. How does the appeal of environmental values influence sustainable entrepreneurial intention? *Int. J. Environ. Res. Public Health* **2021**, *18*, 1070. [\[CrossRef\]](#) [\[PubMed\]](#)
3. Shepherd, D.A.; Patzelt, H. The new field of sustainable entrepreneurship: Studying entrepreneurial action linking "what is to be sustained" with "what is to be developed". *Entrep. Theory Pract.* **2011**, *35*, 137–163. [\[CrossRef\]](#)
4. Abdelwahed, N.A.A.; Soomro, B.A.; Shah, N. The Role of Environment, Business and Human Behavior towards Entrepreneurial Sustainability. *Sustainability* **2022**, *14*, 2517. [\[CrossRef\]](#)
5. Ozaralli, N.; Rivenburgh, N.K. Entrepreneurial intention: Antecedents to entrepreneurial behavior in the USA. and Turkey. *J. Glob. Entrep. Res.* **2016**, *6*, 1. [\[CrossRef\]](#)
6. Schaltegger, S.; Wagner, M. Sustainable entrepreneurship and sustainability innovation: Categories and interactions. *Bus. Strategy Environ.* **2011**, *20*, 222–237. [\[CrossRef\]](#)
7. Soomro, B.A.; Almahdi, H.K.; Shah, N. Perceptions of young entrepreneurial aspirants towards sustainable entrepreneurship in Pakistan. *Kybernetes* **2020**, *50*, 2134–2154. [\[CrossRef\]](#)
8. Abdelwahed, N.A.A.; Soomro, B.A. Attitudes and intentions towards the adoption of mobile learning during COVID-19: Building an exciting career through vocational education. *Educ. + Train.* **2022**. *ahead-of-print*. [\[CrossRef\]](#)
9. Hewlett, S.A.; Sherbin, L.; Sumberg, K. How Gen Y and Boomers will reshape your agenda. *Harv. Bus. Rev.* **2009**, *87*, 3–8.
10. Zahra, S.A.; Gedajlovic, E.; Neubaum, D.O.; Shulman, J.M. A typology of social entrepreneurs: Motives, search processes and ethical challenges. *J. Bus. Ventur.* **2009**, *24*, 519–532. [\[CrossRef\]](#)
11. Hlady-Rispal, M.; Servantie, V. Deconstructing the Way in which Value Is Created in the Context of Social Entrepreneurship. *Int. J. Manag. Rev.* **2016**, *20*, 62–80. [\[CrossRef\]](#)
12. Canestrino, R.; Ćwiklicki, M.; Magliocca, P.; Pawełek, B. Understanding social entrepreneurship: A cultural perspective in business research. *J. Bus. Res.* **2020**, *110*, 132–143. [\[CrossRef\]](#)
13. Soomro, B.A.; Memon, M.; Shah, N. Attitudes towards entrepreneurship among the students of Thailand: An entrepreneurial attitude orientation approach. *Educ. + Train.* **2020**, *63*, 239–255. [\[CrossRef\]](#)
14. Krueger, N.F., Jr.; Reilly, M.D.; Carsrud, A.L. Competing models of entrepreneurial intentions. *J. Bus. Ventur.* **2000**, *15*, 411–432. [\[CrossRef\]](#)
15. Vuorio, A.M.; Puumalainen, K.; Fellnhofer, K. Drivers of entrepreneurial intentions in sustainable entrepreneurship. *Int. J. Entrep. Behav. Res.* **2017**, *24*, 359–381. [\[CrossRef\]](#)
16. Fayolle, A.; Liñán, F.; Moriano, J.A. Beyond entrepreneurial intentions: Values and motivations in entrepreneurship. *Int. Entrep. Manag. J.* **2014**, *10*, 679–689. [\[CrossRef\]](#)
17. Soomro, B.A.; Shah, N. Entrepreneurship education, entrepreneurial self-efficacy, need for achievement and entrepreneurial intention among commerce students in Pakistan. *Educ. + Train.* **2021**, *64*, 107–125. [\[CrossRef\]](#)
18. Ali, A.; Topping, K.J.; Tariq, R.H. (2011). Entrepreneurial attitudes among potential entrepreneurs. *Pak. J. Commer. Soc. Sci. (PJCSS)* **2011**, *5*, 12–46.
19. Al-Habib, M. Identifying The Traits Of Entrepreneurs In A University Setting: An Empirical Examination Of Saudi Arabian University Students. *Int. Bus. Econ. Res. J. (IBER)* **2012**, *11*, 1019–1028. [\[CrossRef\]](#)
20. Elnadi, M.; Gheith, M.H. Entrepreneurial ecosystem, entrepreneurial self-efficacy, and entrepreneurial intention in higher education: Evidence from Saudi Arabia. *Int. J. Manag. Educ.* **2021**, *19*, 100458. [\[CrossRef\]](#)
21. Alshebami, A.S. Psychological Features and Entrepreneurial Intention among Saudi Small Entrepreneurs during Adverse Times. *Sustainability* **2022**, *14*, 7604. [\[CrossRef\]](#)
22. Naushad, M. A study on the antecedents of entrepreneurial intentions among Saudi students. *Entrep. Sustain. Issues* **2018**, *5*, 600–617. [\[CrossRef\]](#)
23. Elnadi, M.; Gheith, M.H.; Farag, T. How does the perception of entrepreneurial ecosystem affect entrepreneurial intention among university students in Saudi Arabia? *Int. J. Entrep.* **2020**, *24*, 1–15.
24. Choukir, J.; Aloulou, W.J.; Ayadi, F.; Mseddi, S. Influences of role models and gender on Saudi Arabian freshman students' entrepreneurial intention. *Int. J. Gen. Entrep.* **2019**, *11*, 186–206. [\[CrossRef\]](#)
25. Soomro, B.A.; Shah, N. Developing attitudes and intentions among potential entrepreneurs. *J. Enterp. Inf. Manag.* **2015**, *28*, 304–322. [\[CrossRef\]](#)
26. Tang, K.H.D. Correlation between sustainability education and engineering students' attitudes towards sustainability. *Int. J. Sustain. High. Educ.* **2018**, *19*, 459–472. [\[CrossRef\]](#)
27. Heeren, A.J.; Singh, A.S.; Zwickle, A.; Koontz, T.M.; Slagle, K.M.; McCreery, A.C. Is sustainability knowledge half the battle? An examination of sustainability knowledge, attitudes, norms, and efficacy to understand sustainable behaviours. *Int. J. Sustain. High. Educ.* **2016**, *17*, 613–632. [\[CrossRef\]](#)
28. Kagawa, F. Dissonance in students' perceptions of sustainable development and sustainability: Implications for curriculum change. *Int. J. Sustain. High. Educ.* **2007**, *8*, 317–338. [\[CrossRef\]](#)
29. Yildirim, F.; Öztürk, H.; Abukan, B. Examination of social workers' attitudes towards sustainable development and environment in the focus of the COVID-19 pandemic. *Int. J. Sustain. High. Educ.* **2021**, *22*, 1592–1608. [\[CrossRef\]](#)

30. Soomro, B.A.; Shah, N. Examining the intention to stay home due to COVID-19: A pandemic's second wave outlook. *Health Educ.* **2021**, *121*, 420–435. [[CrossRef](#)]
31. Kanapathy, S.; Lee, K.E.; Mokhtar, M.; Zakaria, S.S.Z.; Sivapalan, S.; Zahidi, M.A. Sustainable chemistry teaching at the pre-university level: Barriers and opportunities for university educators. *Int. J. Sustain. High. Educ.* **2019**, *20*, 784–802. [[CrossRef](#)]
32. Davis, G.; O'Callaghan, F.; Knox, K. Sustainable attitudes and behaviours amongst a sample of non-academic staff: A case study from an Information Services Department, Griffith University, Brisbane. *Int. J. Sustain. High. Educ.* **2009**, *10*, 136–151. [[CrossRef](#)]
33. Soomro, B.A.; Lakhan, G.R.; Mangi, S.; Shah, N. Predicting entrepreneurial intention among business students of public sector universities of Pakistan: An application of the entrepreneurial event model. *World J. Entrep. Manag. Sustain. Dev.* **2020**, *16*, 219–230. [[CrossRef](#)]
34. Oftedal, E.M.; Iakovleva, T.A.; Foss, L. University context matter: An institutional perspective on entrepreneurial intentions of students. *Educ. + Train.* **2018**, *60*, 873–890. [[CrossRef](#)]
35. Urban, B.; Galawe, J. The mediating effect of self-efficacy on the relationship between moral judgement, empathy and social opportunity recognition in South Africa. *Int. J. Entrep. Behav. Res.* **2020**, *26*, 349–372. [[CrossRef](#)]
36. Puni, A.; Anlesinya, A.; Korsorku, P.D.A. Entrepreneurial education, self-efficacy and intentions in Sub-Saharan Africa. *Afr. J. Econ. Manag. Stud.* **2018**, *9*, 492–511. [[CrossRef](#)]
37. Fatoki, O. Sustainability orientation and sustainable entrepreneurial intentions of university students in South Africa. *Entrep. Sustain. Issues* **2019**, *7*, 990–999. [[CrossRef](#)]
38. Song, G.; Min, S.; Lee, S.; Seo, Y. The effects of network reliance on opportunity recognition: A moderated mediation model of knowledge acquisition and entrepreneurial orientation. *Technol. Forecast. Soc. Chang.* **2017**, *117*, 98–107. [[CrossRef](#)]
39. Kautonen, T.; Van Gelderen, M.; Tornikoski, E.T. Predicting entrepreneurial behaviour: A test of the theory of planned behaviour. *Appl. Econ.* **2013**, *45*, 697–707. [[CrossRef](#)]
40. Ndaghu, J.; Gwems, J.; Wajiga, H.; Augustine, M. Shapero's Model: A Veritable Tool for Explaining Entrepreneurial Intentions and Attitudes among Management Technology Students in Mautech Yola, Adamawa State, Nigeria. *Int. J. Bus. Manag. Invent.* **2016**, *5*, 19–26.
41. Anjum, T.; Sharifi, S.; Nazar, N.; Farrukh, M. Determinants of Entrepreneurial Intentions Using Theory of Planned Behavior. *Manag. Theory Stud. Rural Bus. Infrastruct. Dev.* **2018**, *40*, 429–441. [[CrossRef](#)]
42. Luthje, C.; Franke, N. The 'making† of an entrepreneur: Testing a model of entrepreneurial intent among engineering students at MIT. *R&D Manag.* **2003**, *33*, 135–147. [[CrossRef](#)]
43. Maheshwari, G.; Kha, K.L. Investigating the relationship between educational support and entrepreneurial intention in Vietnam: The mediating role of entrepreneurial self-efficacy in the theory of planned behavior. *Int. J. Manag. Educ.* **2022**, *20*, 100553. [[CrossRef](#)]
44. Kuehn, K.W. Entrepreneurial intentions research: Implications for entrepreneurship education. *J. Entrep. Educ.* **2008**, *11*, 87–132.
45. Silangen, P. The effect of entrepreneurship education on entrepreneurial intention in Indonesia. *DeReMa (Dev. Res. Manag.) J. Manaj.* **2016**, *11*, 67–86.
46. Schlaegel, C.; Koenig, M. Determinants of Entrepreneurial Intent: A Meta-Analytic Test and Integration of Competing Models. *Entrep. Theory Pract.* **2014**, *38*, 291–332. [[CrossRef](#)]
47. Hardin-Fanning, F.; Ricks, J.M. Attitudes, social norms and perceived behavioral control factors influencing participation in a cooking skills program in rural Central Appalachia. *Glob. Health Promot.* **2016**, *24*, 43–52. [[CrossRef](#)]
48. Fellnhofner, K.; Mueller, S. "I want to be like you!" The influence of role models on entrepreneurial intention. *J. Enterprising Cult.* **2018**, *26*, 113–153. [[CrossRef](#)]
49. Ramayah, T.; Rahman, S.A.; Taghizadeh, S.K. Modelling green entrepreneurial intention among university students using the entrepreneurial event and cultural values theory. *Int. J. Entrep. Ventur.* **2019**, *11*, 394–412. [[CrossRef](#)]
50. Sharahiley, S.M. Examining Entrepreneurial Intention of the Saudi Arabia's University Students: Analyzing Alternative Integrated Research Model of TPB and EEM. *Glob. J. Flex. Syst. Manag.* **2019**, *21*, 67–84. [[CrossRef](#)]
51. Al-Mamary, Y.H.S.; Abdulrab, M.; Alwaheeb, M.A.; Alshammari, N.G.M. Factors impacting entrepreneurial intentions among university students in Saudi Arabia: Testing an integrated model of TPB and EO. *Educ. + Train.* **2020**, *62*, 779–803. [[CrossRef](#)]
52. Soomro, B.A.; Lakhan, G.R.; Shah, N. Knowledge, attitudes and practices towards the spread of COVID-19: A health counseling initiative among potential entrepreneurs of FUUAST. *Heal. Educ.* **2021**, *121*, 670–682. [[CrossRef](#)]
53. Krueger, N. The Impact of Prior Entrepreneurial Exposure on Perceptions of New Venture Feasibility and Desirability. *Entrep. Theory Pract.* **1993**, *18*, 5–21. [[CrossRef](#)]
54. Sarstedt, M.; Hair, J.F.; Ringle, C.M.; Thiele, K.O.; Gudergan, S.P. Estimation issues with PLS and CBSEM: Where the bias lies! *J. Bus. Res.* **2016**, *69*, 3998–4010. [[CrossRef](#)]
55. Wasdani, K.P.; Mathew, M. Potential for opportunity recognition: Differentiating entrepreneurs. *Int. J. Entrep. Small Bus.* **2014**, *23*, 336–362. [[CrossRef](#)]
56. Farsi, J.Y.; Arabiun, A.; Moradi, M. The impact of opportunity recognition skills training on entrepreneurial intention of female nursing students. *J. Knowl. Manag. Econ. Inf. Technol.* **2012**, *2*, 411–423.
57. Ruiz-Palomino, P.; Martínez-Cañas, R. From opportunity recognition to the start-up phase: The moderating role of family and friends-based entrepreneurial social networks. *Int. Entrep. Manag. J.* **2021**, *17*, 1159–1182. [[CrossRef](#)]

58. Bulanova, O.; Isaksen, E.J.; Kolvereid, L. Growth aspirations among women entrepreneurs in high growth firms. *Balt. J. Manag.* **2016**, *11*, 187–206. [[CrossRef](#)]
59. Shane, S.; Venkataraman, S. The Promise of Entrepreneurship as a Field of Research. *Acad. Manag. Rev.* **2000**, *25*, 217–226. [[CrossRef](#)]
60. Yasir, N.; Mahmood, N.; Jutt, A.A.; Babar, M.; Irfan, M.; Jamil, F.; Shaukatg, M.Z.; Khanh, H.M.; Liren, A. How can entrepreneurial self-efficacy, proactivity and creativity enhance sustainable recognition opportunity? The effect of entrepreneurial alertness is to mediate the formation of sustainable entrepreneurial intention. *Rev. Argent. Clin. Psicol.* **2020**, *29*, 1004–1023.
61. Bapoo, M.A.; Tehseen, S.; Haider, S.A.; Yusof, M.; Motaghi, H. Sustainability orientation and sustainable entrepreneurship intention: The mediating role of entrepreneurial opportunity recognition. *Acad. Entrep. J.* **2022**, *28*, 1–23.
62. Hanohov, R.; Baldacchino, L. Opportunity recognition in sustainable entrepreneurship: An exploratory study. *Int. J. Entrep. Behav. Res.* **2017**, *24*, 333–358. [[CrossRef](#)]
63. Sargani, G.R.; Jiang, Y.; Zhou, D.; Chandio, A.A.; Hussain, M.; Khan, N. Endorsing Sustainable Enterprises Among Promising Entrepreneurs: A Comparative Study of Factor-Driven Economy and Efficiency-Driven Economy. *Front. Psychol.* **2021**, *12*, 735127. [[CrossRef](#)]
64. Sher, A.; Abbas, A.; Mazhar, S.; Azadi, H.; Lin, G. Fostering sustainable ventures: Drivers of sustainable start-up intentions among aspiring entrepreneurs in Pakistan. *J. Clean. Prod.* **2020**, *262*, 121269. [[CrossRef](#)]
65. Solesvik, M.Z.; Westhead, P.; Kolvereid, L.; Matlay, H. Student intentions to become self-employed: The Ukrainian context. *J. Small Bus. Enterp. Dev.* **2012**, *19*, 441–460. [[CrossRef](#)]
66. Dabic, M.; Daim, T.; Bayraktaroglu, E.; Novak, I.; Basic, M. Exploring gender differences in attitudes of university students towards entrepreneurship: An international survey. *Int. J. Gen. Entrep.* **2012**, *4*, 316–336. [[CrossRef](#)]
67. Boukamcha, F. Impact of training on entrepreneurial intention: An interactive cognitive perspective. *Eur. Bus. Rev.* **2015**, *27*, 593–616. [[CrossRef](#)]
68. Tehseen, S.; Haider, S. Impact of Universities' Partnerships on Students' Sustainable Entrepreneurship Intentions: A Comparative Study. *Sustainability* **2021**, *13*, 5025. [[CrossRef](#)]
69. Munir, H.; Ramzan, S.; Wang, M.; Rasool, Y.; Sumbal, M.S.; Iqbal, A. Combining the social cognitive career theory, contextual factors and entrepreneurship education programs in intention-based model: A tale of two diverse regions. *J. Entrep. Emerg. Econ.* **2021**, *14*, 392–421. [[CrossRef](#)]
70. Dissanayake, D. The Impact of Perceived Desirability and Perceived Feasibility on Entrepreneurial Intention among Undergraduate Students in Sri Lanka: An Extended Model. *Kelaniya J. Manag.* **2014**, *2*, 39–57. [[CrossRef](#)]
71. Han, W.; Luo, Y.; Huang, Q.; Yang, J. The role of opportunity feasibility beliefs and bribery on resource acquisition speed and new venture emergence. *J. Bus. Res.* **2022**, *149*, 518–527. [[CrossRef](#)]
72. Berry, G.; Shabana, K.M. Adding a strategic lens to feasibility analysis. *N. Engl. J. Entrep.* **2020**, *23*, 67–78. [[CrossRef](#)]
73. Baručić, A.; Umihanić, B. Entrepreneurship education as a factor of entrepreneurial opportunity recognition for starting a new business. *Manag. J. Contemp. Manag. Issues* **2016**, *21*, 27–44.
74. Ali, B.; Shah, N.; Anwar, S. Investigating entrepreneurial intention through entrepreneurial event model (EEM) among graduate and master students in public sector universities of Thailand. *Asia Pac.-Annu. Res. J. Far East South East Asia* **2016**, *34*, 36–53.
75. Ali, B.; Shah, N.; Mangi, S. Entrepreneurial Intention among Physical and Health Education Students in Public sector Universities of Pakistan. *Shield-Res. J. Phys. Educ. Sports Sci.* **2019**, *2*, 1–13.
76. Ahmad, N.H.; Ramayah, T.; Mahmud, I.; Musa, M.; Anika, J.J. Entrepreneurship as a preferred career option: Modelling tourism students' entrepreneurial intention. *Educ. + Train.* **2019**, *61*, 1151–1169. [[CrossRef](#)]
77. Yousaf, U.; Shamim, A.; Siddiqui, H.; Raina, M. Studying the influence of entrepreneurial attributes, subjective norms and perceived desirability on entrepreneurial intentions. *J. Entrep. Emerg. Econ.* **2015**, *7*, 23–34. [[CrossRef](#)]
78. Duong, C.D.; Le, T.L. ADHD symptoms and entrepreneurial intention among Vietnamese college students: An empirical study. *J. Entrep. Emerg. Econ.* **2021**, *14*, 495–522. [[CrossRef](#)]
79. Hassan, A.; Saleem, I.; Anwar, I.; Hussain, S.A. Entrepreneurial intention of Indian university students: The role of opportunity recognition and entrepreneurship education. *Educ. + Train.* **2020**, *62*, 843–861. [[CrossRef](#)]
80. Wannamakok, W.; Chang, Y.-Y. Understanding nascent women entrepreneurs: An exploratory investigation into their entrepreneurial intentions. *Gen. Manag. Int. J.* **2020**, *35*, 553–566. [[CrossRef](#)]
81. Kelly, L.; Dorian, M. Doing Well and Good: An Exploration of the Role of Mindfulness in the Entrepreneurial Opportunity Recognition and Evaluation Process. *N. Engl. J. Entrep.* **2017**, *20*, 26–36. [[CrossRef](#)]
82. Elali, W.; Al-Yacoub, B. Factors affecting entrepreneurial intentions among Kuwaitis. *World J. Entrep. Manag. Sustain. Dev.* **2016**, *12*, 18–34. [[CrossRef](#)]
83. Liu, T.-C.; Chen, J.V.; Hsu, P.-Y. Opportunity recognition and cooperation flexibility of entrepreneurial franchisees. *Ind. Manag. Data Syst.* **2014**, *114*, 506–525. [[CrossRef](#)]
84. Polas, M.R.H.; Raju, V.; Muhibullah; Tabash, M.I. Rural women characteristics and sustainable entrepreneurial intention: A road to economic growth in Bangladesh. *J. Enterprising Communities People Places Glob. Econ.* **2021**, *16*, 421–449. [[CrossRef](#)]
85. Suwardi, D.M.; Machmud, A.; Supardi, E.; Iswanti, I. Opportunity recognition and green entrepreneurial intention: The moderating effect of entrepreneurship education. *JPBM J. Pendidik. Bisnis Dan Manaj.* **2021**, *7*, 42–55.

86. Dahalan, N.; Jaafar, M.; Rosdi, S.A.M. Attitude and Entrepreneurial Intention Among Rural Community: The Mediating Role of Entrepreneurial Opportunity Recognition. *SHS Web Conf.* **2015**, *18*, 1005. [CrossRef]
87. Anwar, I.; Thoudam, P.; Saleem, I. Role of entrepreneurial education in shaping entrepreneurial intention among university students: Testing the hypotheses using mediation and moderation approach. *J. Educ. Bus.* **2021**, *97*, 8–20. [CrossRef]
88. Asante, E.A.; Affum-Osei, E. Entrepreneurship as a career choice: The impact of locus of control on aspiring entrepreneurs' opportunity recognition. *J. Bus. Res.* **2019**, *98*, 227–235. [CrossRef]
89. Fitzsimmons, J.; Douglas, E. Interaction between feasibility and desirability in the formation of entrepreneurial intentions. *J. Bus. Ventur.* **2011**, *26*, 431–440. [CrossRef]
90. Karimi, S.; Biemans, H.J.A.; Lans, T.; Chizari, M.; Mulder, M. The Impact of Entrepreneurship Education: A Study of Iranian Students' Entrepreneurial Intentions and Opportunity Identification. *J. Small Bus. Manag.* **2014**, *54*, 187–209. [CrossRef]
91. Hajizadeh, A.; Zali, M. Prior knowledge, cognitive characteristics and opportunity recognition. *Int. J. Entrep. Behav. Res.* **2016**, *22*, 63–83. [CrossRef]
92. Ramona, S.E. Advantages and disadvantages of quantitative and qualitative information risk approaches. *Chin. Bus. Rev.* **2011**, *10*, 1106–1110.
93. Cummins, R.A.; Gullone, E. Why we should not use 5-point Likert scales: The case for subjective quality of life measurement. *Proc. Second. Int. Conf. Qual. Life Cities* **2000**, *74*, 74–93.
94. Savelle, T. The advantages and disadvantages of quantitative methods in schoolscape research. *Linguist. Educ.* **2018**, *44*, 31–44. [CrossRef]
95. Cunningham, J.B.; McCrum-Gardner, E. Power, effect and sample size using GPower: Practical issues for researchers and members of research ethics committees. *Evid. Based Midwifery* **2007**, *5*, 132–136.
96. Erdfelder, E.; Faul, F.; Buchner, A. GPOWER: A general power analysis program. *Behav. Res. Methods Instrum. Comput.* **1996**, *28*, 1–11. [CrossRef]
97. Shah, N.; Soomro, B.A. Internal green integration and environmental performance: The predictive power of proactive environmental strategy, greening the supplier, and environmental collaboration with the supplier. *Bus. Strat. Environ.* **2020**, *30*, 1333–1344. [CrossRef]
98. Albuam, G.; Oppenheim, A.N. Questionnaire Design, Interviewing and Attitude Measurement. *J. Mark. Res.* **1993**, *30*, 393. [CrossRef]
99. Hassan, Z.A.; Schattner, P.; Mazza, D. Doing a pilot study: Why is it essential? *Malays. Fam. Physician Off. J. Acad. Fam. Physicians Malays.* **2006**, *1*, 70–73.
100. Morin, K.H. Writing for the *Journal of Nursing Education*: Key Questions for Authors. *J. Nurs. Educ.* **2014**, *53*, 547–548. [CrossRef]
101. Chan, L.L.; Idris, N. Validity and reliability of the instrument using exploratory factor analysis and Cronbach's alpha. *Int. J. Acad. Res. Bus. Soc. Sci.* **2017**, *7*, 400–410.
102. Hair, J.F.; Risher, J.J.; Sarstedt, M.; Ringle, C.M. When to use and how to report the results of PLS-SEM. *Eur. Bus. Rev.* **2019**, *31*, 2–24. [CrossRef]
103. Osgood, C.E.; Suci, G.J.; Tannenbaum, P.H. *The Measurement of Meaning*, 9th ed.; University of Illinois Press: Champaign, IL, USA, 1975.
104. UNDP. Sustainable Development Goals (SDGs), UNDP. 2015. Available online: [www.undp.org/content/undp/en/home/sdgoverview/post-2015-development-agenda.html](http://www.undp.org/content/undp/en/home/sdgoverview/post-2015-development-agenda.html) (accessed on 8 August 2022).
105. Liñán, F.; Chen, Y.-W. Development and Cross-Cultural Application of a Specific Instrument to Measure Entrepreneurial Intentions. *Entrep. Theory Pract.* **2009**, *33*, 593–617. [CrossRef]
106. Peterman, N.E.; Kennedy, J. Enterprise Education: Influencing Students' Perceptions of Entrepreneurship. *Entrep. Theory Pract.* **2003**, *28*, 129–144. [CrossRef]
107. Huang, J. *Study on the Impact of Environmental Characteristics and Entrepreneurial Network on Entrepreneurial Opportunity Identification*; Jilin University: Changchun, China, 2010.
108. Brenner, O.C.; Pringle, C.D.; Greenhaus, J.H. Perceived fulfillment of organizational employment versus entrepreneurship: Work values and career intentions of business college graduates. *J. Small Bus. Manag.* **1991**, *29*, 62–74.
109. Fisher, M.J.; Marshall, A. Understanding descriptive statistics. *Aust. Crit. Care* **2009**, *22*, 93–97. [CrossRef]
110. Benesty, J.; Chen, J.; Huang, Y.; Cohen, I. Pearson Correlation Coefficient. In *Noise Reduction in Speech Processing*; Springer: Berlin/Heidelberg, Germany, 2009; pp. 1–4.
111. Tabachnick, B.G.; Fidell, L.S. *Using Multivariate Statistics*, 5th ed.; Pearson International: Upper Saddle River, NJ, USA, 2007.
112. Henseler, J.; Ringle, C.M.; Sarstedt, M. A new criterion for assessing discriminant validity in variance-based structural equation modeling. *J. Acad. Mark. Sci.* **2015**, *43*, 115–135. [CrossRef]
113. Hair, J.; Black, W.; Babin, B.; Anderson, R.; Tatham, R. *Multivariate Data Analysis*, 6th ed.; Pearson Prentice Hall, Pearson Education, Inc.: Upper Saddle River, NJ, USA, 2006.
114. Kline, S.J.; Rosenberg, N. An overview of innovation. *Stud. Sci. Innov. Process Sel. Work. Nathan Rosenb.* **2010**, 173–203. [CrossRef]
115. Considine, J.; Botti, M.; Thomas, S. Design, format, validity and reliability of multiple choice questions for use in nursing research and education. *Collegian* **2005**, *12*, 19–24. [CrossRef]
116. Afthanorhan, W.M.A.B.W. A comparison of partial least square structural equation modeling (PLS-SEM) and covariance based structural equation modeling (CB-SEM) for confirmatory factor analysis. *Int. J. Eng. Sci. Innov. Technol.* **2013**, *2*, 198–205.
117. Chin, W.W. The partial least squares approach to structural equation modeling. *Mod. Methods Bus. Res.* **1998**, *295*, 295–336.

118. Dash, G.; Paul, J. CB-SEM vs PLS-SEM methods for research in social sciences and technology forecasting. *Technol. Forecast. Soc. Chang.* **2021**, *173*, 121092. [[CrossRef](#)]
119. Bentler, P.M.; Huang, W. On components, latent variables, PLS and simple methods: Reactions to Rigdon's rethinking of PLS. *Long Range Plan.* **2014**, *47*, 138–145. [[CrossRef](#)] [[PubMed](#)]
120. Henseler, J.; Dijkstra, T.K.; Sarstedt, M.; Ringle, C.M.; Diamantopoulos, A.; Straub, D.W.; Ketchen, D., Jr.; Joseph, F.; Hair, F.; Hult, G.T.M.; et al. Common beliefs and reality about PLS: Comments on Rönkkö and Evermann. *Organ. Res. Methods* **2014**, *17*, 182–209. [[CrossRef](#)]
121. Rigdon, E.E.; Sarstedt, M.; Ringle, C.M. On Comparing Results from CB-SEM and PLS-SEM: Five Perspectives and Five Recommendations. *ZFP J. Res. Manag.* **2017**, *39*, 4–16. [[CrossRef](#)]