

 Open access • Posted Content • DOI:10.20944/PREPRINTS201810.0182.V2

## **Development and Performance Evaluation of a Novel Fire Detection and Extinguishing system: Towards Industrial Automation — [Source link](#)**

Selim Reza, SM Mamun

**Published on:** 30 Oct 2018

**Topics:** Fire detection

Related papers:

- [Computer lab automatic fire extinguishing system](#)
- [Intelligence fire monitoring system](#)
- [Solar-energy anti-theft alarm and self-extinguishing monitoring system based on Zigbee network](#)
- [Development of Low Cost Safety Home Automation System using GSM Network](#)
- [Firefighting automatic fire extinguishing system on-line monitoring device based on wireless fidelity \(WIFI\) wireless communication](#)

Share this paper:    

View more about this paper here: <https://typeset.io/papers/development-and-performance-evaluation-of-a-novel-fire-3j430ouyp6>

# Development and Performance Evaluation of a Novel Fire Detection and Extinguishing system: Towards Industrial Automation

Md. Selim Reza<sup>1</sup>, SM Mamun<sup>2</sup>

<sup>1</sup>(Lecturer, Department of Natural Sciences, BGMEA University of Fashion & Technology, Bangladesh)

<sup>2</sup>(Professor, Department of EEE, University of Dhaka, Bangladesh)

## **Abstract:**

Fire accidents are causing a huge human death as well as economic losses throughout the world every year. But a novel fire detection and extinguishing system could reduce these losses to a great extent. We are proposing a cost effective and yet very efficient system which has been developed in our laboratory and evaluated while in operation. Our system consists of two units: detection unit and extinguishing unit. For detection purposes we used smoke, IR and temperature sensors. While for extinguishing purposes we used both foam and water. We used a PC to process and control our system through LabVIEW software of National Instrument, USA. The detection unit will send signal through a wireless module to PC if fire is detected. Then PC (LabVIEW) will process the signal and using relay module first of all the electric power and gas lines will be turned off. The extinguishing unit will then release foam or water to extinguish the fire. The system will send SMS to the predefined numbers using GSM module. Our system is location independent as it uses GSM and can be operated from remote location using wireless module. After performance evaluation it was found to be fast and reliable.

## **Keywords:**

Detection unit; Extinguishing unit; IR; SMS; GSM module; Wireless module; LabVIEW; Foam

## **Introduction:**

We are in an advanced world of technology. But it has been noticed with great concern that the fire accidents and casualties are also increasing proportionally every year. According to the yearly report, 2018 of International Association of Fire and Rescue Services average number of fires (2012 to 2016) only in USA is 1320100 per year [1]. According to Bangladesh Fire Service and Civil Defense, fire incidents kill 233 people and injure 5000 every year in Bangladesh. In 2016 alone there has been 16858 fire incidents in Bangladesh causing 240 crore & 43 lakh financial loss, killed 152 and 247 were injured [2]. According to the National Fire Protection Association, USA some main reasons behind fire accidents are i) flammable liquids and gases, ii) faulty equipment and machinery & iii) electrical hazards [3]. So to cope up these disasters we need to design a smart detection and extinguishing system on the basis of

above mentioned reasons. There has been a huge effort over the years to design and develop such systems. Feiniu Yuan[4] designed a fire detection and suppression system based on widely available video surveillance. He used traditional CCD cameras for fire recognition and water gun for suppression [4]. Antidio Viguria et al.[5] proposed a system that utilizes heterogeneous robots (aerial and ground) for fire detection and extinguishing purposes. They developed a distributed market-based algorithm called S + T to solve the multi-robot task allocation problem. Lee et al. [6] developed a fire detection system based on controller area network (CAN). We are proposing a LabVIEW based fire detection and extinguishing system which is cost effective and reliable.

Trends in fires in some of the countries of the world in 2012-2016

N o.	Country	Population, thousand inh.	Number of fires					Average	
			2012	2013	2014	2015	2016	Per year	Per thousand inh. a year
1	USA	323,128	1375000	1240000	1298000	1345500	12342000	1320100	4.09
2	Russia	146270	162900	152959	150437	145900	139500	150339	1.03
3	France	66628	306871	281908	270900	300667	285700	289209	4.34
4	Great Britain	63786	272800	192700	212500	191647	201009	214131	3.36
5	Spain	47079	142500	135000	128000	137000	122828	133066	2.83

Trends in fire deaths in some of the countries of the world in 2012-2016

N o.	Country	Population, thousand inh.	Number of fires					Average number per		
			2012	2013	2014	2015	2016	Year	100000 inh.	100 fires
1	USA	323,128	2855	3420	3275	3280	3390	3244	1	0.2
2	Russia	146270	11652	10601	10138	9405	8749	10109	6.9	6.7
3	France	66628	362	321	280	335	289	317	0.5	0.1
4	Great Britain	63786	380	350	322	325	-	344	0.5	0.2
5	Spain	47079	170	132	162	143	175	156	0.3	0.1

## Methodology:

Our system consists of three units i) detection unit, ii) receiving and processing unit & iii) warning and extinguishing unit. The detection unit is responsible for the detection of fire. It consists of three sensors and a transmitter. We used MQ-5 gas sensor, IR sensor and LM35 temperature sensor for detection

purpose. For transmission purposes we used JMR-TX<sub>1</sub>Transmission module. The receiving part will receive the transmitted signal from the detection unit. The processing part will confirm the detection of fire following some specific criteria. The warning unit is for raising awareness among the inhabitants with the help of Siren and SMS. The responsibility of the extinguishing unit is to suppress fire after detection. We used both foam and water for extinguishing purpose. Figure below shows the block diagram of our system.

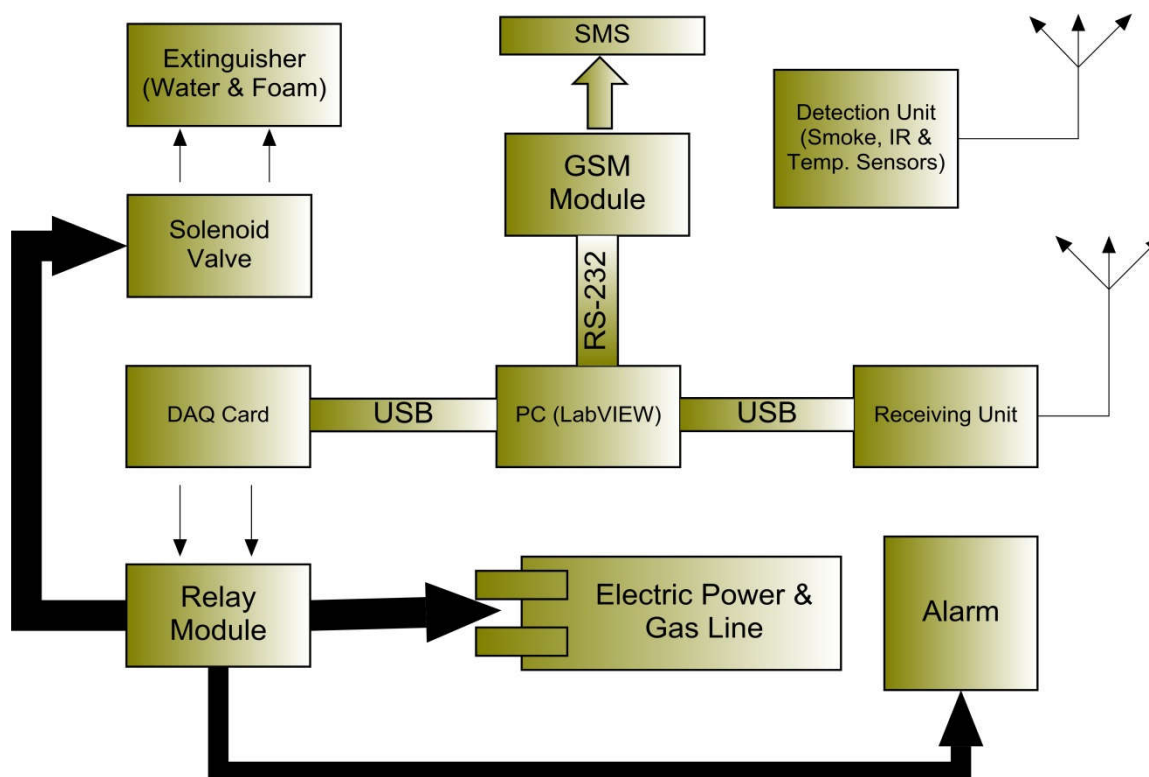

Figure 1: Block diagram of the system.

### **Detection Unit:**

Detection is one of the main parts of an extinguishing system and is based on various properties of fire such as smoke emission, rise in temperature and optical radiation emission [8]. We used MQ-5 sensor for detection of gas and smoke, LM35 temperature sensor for detection of rise in temperature and SKU152020 IR flame sensor for detection of optical flames. The MQ-5 is chosen because it has high sensitivity, faster response, long life and it needs simple circuitry to drive. It can detect propane and butane as well as other natural gases, cigarette smoke and alcohol. The LM35 is selected as it doesn't need any external calibration or trimming for precision measurement in Centigrade scale. By analyzing optical properties of fire we can find that it will emit some ultra violet and even some x-rays but that amount is negligible. Most of the radiation emitted is in the infrared spectrum [8]. So we selected the SKU152020 IR flame sensor module for the detection of optical flame. A separate PCB has been

made combining these sensors along with a transmitter for accurate detection and transmission of the signal to the receiving unit. We used ATmega8 microcontroller for proper operation of the unit and compiled it with BASCOM AVR. The flowchart of figure 3 explains the operation of the detection unit.

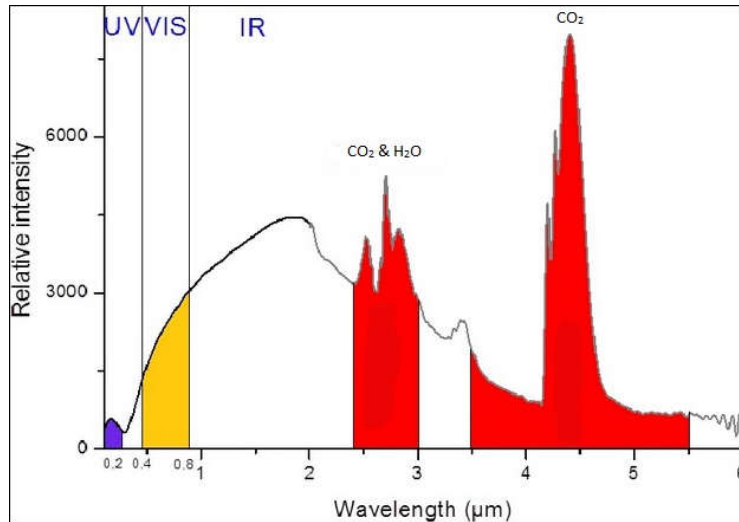

Figure 2: Typical emission spectrum of hydrocarbon fire

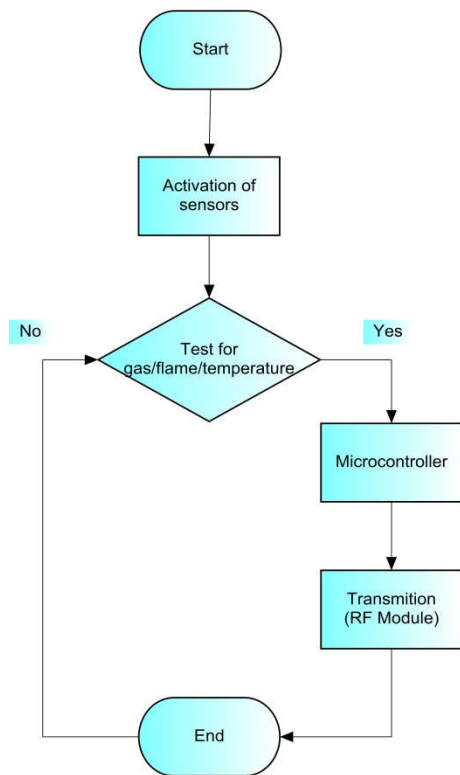

Figure 3: Flow chart explaining the operation of the detection unit.

## Receiving and Processing Unit:

The detection unit will send voltage output signal in the form of string to the receiver via RF transmitter. A separate PCB has been developed containing a RF receiver and PIC16 microprocessor and is connected to PC through USB port. The received signal will be processed by LabVIEW program which is a popular measuring and controlling software from the National Instrument, USA. A virtual instrument has been made in this purpose. The MQ-5 will always send GAS if gas/smoke is detected to the receiver. The program will then compare whether the string (GAS) is matched or not. In the same way the flame sensor module will send FLAME if detected to the receiver. The program will then compare whether the string (FLAME) is matched or not. The LM35 will send the temperature reading in centigrade to the receiver. The program will check whether the reading is equal or greater than 100 °C. Following table shows the general temperatures of sources of ignition and from it we decided to confirm fire temperature to be 100 °C and more [9]. If these criteria are met the program will confirm the detection of fire and will move to the next step. The whole process of the receiving and processing unit is shown in the flow chart of figure 4.

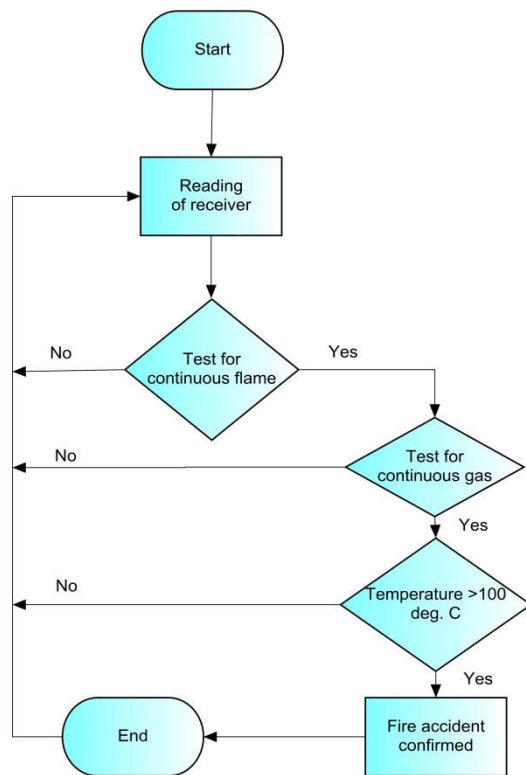

Figure 4: Mechanism of receiving and processing unit.

Sources of ignition- general temperatures

Source	Temperature (Celsius)
Cigarettes - ventilated	400°-780°
Cigarettes - unventilated conditions	288°
Cigarettes - insulated and smoldering	510°-621°
Match	600°-800°
Candle flame	600°-1400°
Stove element	>550°
Fluorescent light	60°-80°
Incandescent light	100°-300°
Tungsten halogen light	600°-900°
Electrical arcing	to 3750°
Electrical spark	1316°
Lightning	30000°
Oxyacetylene	3300°
Industrial furnaces	1700°
Bunsen burner	1570°

### **Warning and extinguishing unit:**

The warning part consists of a relay based siren and GSM based Short Message Service (SMS). When fire is detected the LabVIEW will send voltage signal to the Data Acquisition (DAQ) card and will activate the solid state relay. The mini siren will be activated immediately which is connected to the relay. In addition, the system will send SMS to the related person using GSM modem. The extinguishing part consists of a solenoid valve, fire extinguisher and related pipe, nozzle, etc. When fire is detected the voltage signal will be sent to the relay through DAQ card. Then the solenoid valve which is connected to the relay will be activated which will unleash the fire extinguisher (foam or water). The fire extinguishing agent will extinguish the flame or gas with pipes and nozzles. The flow chart in figure 5 describes the mechanism of the warning and extinguishing unit.

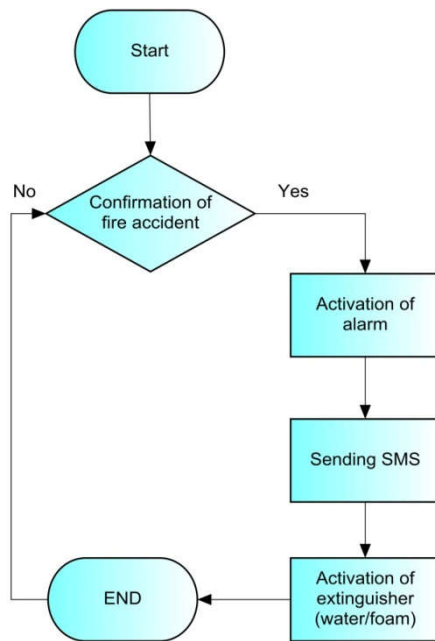

Figure 5: Mechanism of the warning and extinguishing unit of our system.

## **Performance Evaluation:**

Our developed system has been tested under certain circumstances. The detection speed of Liquefied Petroleum Gas (LPG), Natural Gas and Town Gas is very fast. Within seconds of their occurrence our system can detect them. However for cigarette smoke and cooking fumes the system response is a bit slow. The lighter and denser flame can also be detected with very high accuracy and fast response. The following table summarizes the test result of the detection unit.

Response of the detection unit for various gases

No	Materials	Response	Range
1	LPG	very fast	N/A
2	Natural Gas	fast	N/A
3	Town Gas	fast	N/A
4	Cigarette smoke	very slow	N/A
5	Cooking fumes	very slow	N/A
6	Lighter Flame (Any type)	very fast	75 cm
7	Denser Flame (Any type)	very fast	100 cm

The system response of warning and extinguishing unit under certain circumstances are summarized in the following table. For 50 cm and lower distances between the detection and receiving unit we found that the system sometimes gets jammed. It would be due to fact of interference between siren and DAQ card. However the response of the system is generally satisfactory. However with the increase in



distance between the detection and receiving unit the system responses slowly. It is due to the fact that we used low cost sensors and RF module with small detection ranges.

Response of different units in terms of distance between transmitter & receiver

No	Distance between transmitter & receiver	Response	Alarm	SMS	Extinguisher
1	50 cm	Very fast	Jammed	Immediately	Rapid
2	100 cm	Very fast	Immediately	Immediately	Rapid
3	200 cm	Very fast	Immediately	Immediately	Rapid
4	10 m	Fast	Average	Immediately	Average
5	50m	Average	Average	Immediately	Average
6	100m	No response	No response	No response	No response

## **Conclusion:**

A novel automatic PC based fire detection and extinguishing system has been designed and tested. LabVIEW software has been used to develop the virtual instrument as the main control panel and found perfectly working after several tests. The system integrates gas, flame and temperature sensors, interfacing board, relay module, RF module, solenoid valve, fire extinguisher (foam and water), alarm and GSM modem to function with the command from PC through USB port. The prototype system is able to detect fire within few seconds of their occurrence and take necessary measure. With the achievement of all the objectives of this research, we can conclude that the designed system is reliable and cost effective which could be employed as an automatic firefighter in industries to reduce the number of casualties and loss of assets.

## **Future Work:**

The system consists of only three sensors. So it is therefore recommended that a system which accepts as many inputs from sensors as may be required by the user be designed. This may be possible by use of multiplexers. Multi-time usable fire extinguishers are necessary for future upgrades. When these are achieved, detection as well as control of fire will be achieved for a large area. Due to various environmental factors i.e. change in pressure, air flow, etc. normal flow of smoke may be diverted to undesired detection unit. It may trigger undesirable fire extinguisher and would lead to inefficiency. Sensor that uses the coordinate system to check the direction of the flow before triggering the sprinklers is thus required. In addition, sensors that are immune to strong heat, high humidity and dust repellent are also required to enhance the degree of accuracy.

## **References:**

1. N.N. Brushlinsky, M. Ahrens, S.V. Sokolov, P. Wanger, World Fire Statistics, Center of Fire Statistics, 2018
2. ShohelMamun, Why so many recent fires? Dhaka Tribune, March, 2017
3. National Fire Protection Association, USA (NFPA Research: [www.nfpa.org/research](http://www.nfpa.org/research))
4. Yuan, F. An integrated fire detection and suppression system based on widely available video surveillance. In: Machine Vision and Applications, October 2010, Volume 21, Issue 6, pp. 941–948
5. AntidioViguria, Ivan Maza&AnibalOllero(2010)Distributed Service-Based Cooperation in Aerial/Ground Robot Teams Applied to Fire Detection and Extinguishing Missions,Advanced Robotics,24:1-2,1-23,DOI: [10.1163/016918609X12585524300339](https://doi.org/10.1163/016918609X12585524300339)
6. Kyung Chang Lee and Hong-Hee Lee, "Network-based fire-detection system via controller area network for smart home automation," in *IEEE Transactions on Consumer Electronics*, vol. 50, no. 4, pp. 1093-1100, Nov. 2004, DOI: 10.1109/TCE.2004.1362504
7. An Introduction to Combustion: Concepts and Applications, 3rd Edition by S. R. Turns
8. A Guide to Optical Flame Detection – How UV, IR and Imaging Detectors Work by 3M Gas & Flame Detection, USA, July, 2017
9. The Art and Science of Fire Investigation Hardcover – 1990, by John N. Cardoulis