

DEVELOPMENT OF AN EXPERIMENTAL 10 T Nb<sub>3</sub>Sn DIPOLE MAGNET FOR THE CERN LHC\*

H.H.J. ten Kate, A. den Ouden, D. ter Avest, S. Wessel, R. Dubbeldam,<sup>‡</sup>  
W. van Emden,<sup>†</sup> C. Daum,<sup>†</sup> M. Bona,<sup>°</sup> R. Perin.<sup>°</sup>

University of Twente, Applied Superconductivity Centre,  
POB 217, 7500 AE Enschede, (+) NIKHEF-H, Amsterdam;  
(&) HOLEC, Ridderkerk; (@) SMIT WIRE, Nijmegen,  
all in the Netherlands; and (o) CERN, Geneva.

## Abstract

An experimental 1 meter long twin aperture dipole magnet is developed using a high current density Nb<sub>3</sub>Sn conductor in order to attain a magnetic field well beyond 10 T at 4.2 K. The emphasis in this Nb<sub>3</sub>Sn project is on the highest possible field within the known LHC twin aperture configuration. A design target of 11.5 tesla was chosen, a value which can be achieved with the presently available Nb<sub>3</sub>Sn. Though the basic properties of this experimental magnet are the same as those of the reference design, a few new solutions are implemented. The arrangement of the conductors in the magnet cross section has been optimized in a different way also leading to new dimensions of the conductors. The collaring part of the force retaining structure has been changed. The solution of a shrink fit collar has been adopted instead of a conventional collar with pin locking. Further on the two coil systems in the twin aperture magnet are assembled and collared separately instead of using a twin collar enclosing both coil systems. The paper reports on the various design aspects and the present state of development is presented.

## Introduction

A new step forward in the beam energy of a collider corresponds to an increase of the collider diameter or magnetic field. This means for the proposed new Large Hadron Collider LHC at CERN<sup>1,2</sup> which will be implemented in the existing LEP tunnel, that dipole magnets providing a bending field in the 8 to 10 tesla range have to be developed. Thereafter it requires a massive production of 1200 tons of superconducting cables and 1860 dipole magnets in industry.

A collaboration with European laboratories and industries was set up to develop both the NbTi@2 K as the Nb<sub>3</sub>Sn@4 K alternatives.<sup>4,5</sup> The major effort is focused on NbTi because it has been decided to use NbTi technology for the dipole magnets of LHC. As a consequence the magnets have to operate at a reduced temperature of about 1.8 K in stead of the usual 4.2 K in order to have a sufficiently high current density in the NbTi.

At this moment Nb<sub>3</sub>Sn is still not a reliable and efficient solution for the major part of the LHC magnet system with regard to the cost of Nb<sub>3</sub>Sn windings and to the amount of experience with Nb<sub>3</sub>Sn coil manufacturing present in industry. But, on the other hand, when using the commercially available NbTi conductors, it will hardly be possible to attain a reliable 10 T operation of all the 1860 dipole magnets connected in series since the critical current density of industrially made multifilamentary NbTi conductors with 5 μm filament size is still not sufficient for that.

However, when Nb<sub>3</sub>Sn technology is applied, a field level of 10 T or even 11 or 12 tesla could be achieved within the bounds set by the basic LHC dipole geometry. The realization of this is the main task of the magnet development project of which we report here. It concerns the alternative route of using a Nb<sub>3</sub>Sn superconductor at 4.2 K and the pro-

ject includes a renewed design for 11.5 tesla and the practical realization of an experimental dipole magnet. The R&D program was started in 1988, in the framework of a cooperation agreement with CERN, by the Applied Superconductivity Centre of the University of Twente and NIKHEF in collaboration with ECN, HOLEC and SMIT WIRE. In this project the efforts are focused on the highest possible field within the restrictions of the basic LHC magnet design using the Nb<sub>3</sub>Sn conductor with the highest current density.

## LHC dipole magnets

The installation of the LHC magnet system in the existing LEP tunnel is an economic solution. On the other hand, due to the insufficient space for two separate rings, it is necessary to mount both beam tubes into a single yoke and force retaining structure. In Figure 1 a schematic view of this so-called twin aperture magnet is shown. The magnet has a 2-shell coil system with graded current density, surrounded by a single force-retaining structure. This consists of laminated clamping collars, a vertically split and laminated cold iron yoke and an outer shrinking cylinder that handles the major part of the forces. The main parameters of the coil system are given in Table 1.

The joint action of coil clamping collars, iron yoke and the outer cylinder in the "mechanically hybrid" support structure<sup>6</sup> provides sufficient rigidity and controlled dimensions to guarantee the field quality during the entire operation cycle. About 30 % of the dominant force F<sub>x</sub> in the horizontal plane of 4.6 MN (460 tons) per meter at 10 T is taken by the collars and the major part of about 70 % is taken by the outer cylinder. More general information on the magnet technology for LHC can be found in references.<sup>3,5</sup>

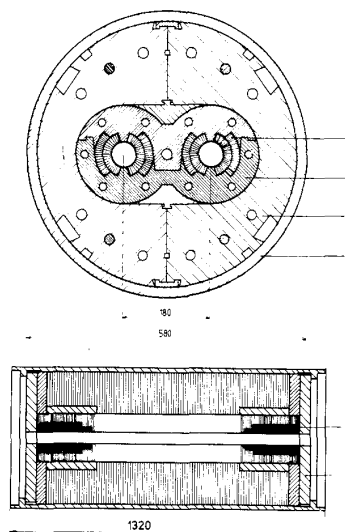

Fig. 1. Schematic view of the cross and longitudinal sections of a 1 meter long 10 T twin aperture LHC dipole magnet showing the main parts: (1) coils, (2) collars, (3) cold iron yoke, (4) outer shrinking cylinder enclosing the cold magnet parts, (5) coil head sections, (6) end-flange, end-plates.

\* These investigations in the programme of the Foundation for Fundamental Research on Matter FOM are supported, in part, by the Netherlands Technology Foundation STW.

Manuscript received September 24, 1990.

High current density Nb<sub>3</sub>Sn conductors

Main parameters of the 10 m long dipole magnets of the LHC 10 T reference design.	
nominal magnetic field	= 10.0 T
max. field in layer 1	= 10.2 T
max. field in layer 2	= 8.7 T
full magnetic length	= 9.5 m
coil inner diameter	= 50 mm
coil outer diameter	= 122 mm
distance between beams	= 180 mm
overall mass	= 18 tons
cold mass	= 15 tons
mass of superconductor	= 600 kg
stored energy at 10 T	= 684 kJ/m
operating current	= ≈15 kA
maximum Lorentz forces:	
in x-direction	= 4.6 MN/m
in y-direction	= -1.2 MN/m
on a coil head	= 0.7 MN

## 8-10 tesla LHC model magnets

A few 1 meter long model magnets have already been built<sup>4</sup> and others are under construction now. The 9 to 10 tesla range has already been attained in these short models. Two 1 meter single aperture 8 T NbTi model magnets were built by ANSALDO and attained 9.3 T at about 2 K. Four 1 meter twin aperture 10 T NbTi model magnets which are now in production in the European industry at HOEC (NL), ELIN (A), Ansaldo (I) and Jeumont Schneider (F), will be tested during the coming months. A 9 m long NbTi model magnet has been made by ABB to gain experience with long twin aperture magnets using existing HERA tooling, coil geometry and conductors. The next step, to built about 8 full length prototype magnets will start by the end of this year, and with these units a first string test can be performed in 1992.

Besides the work described also in this paper,<sup>9-11</sup> Nb<sub>3</sub>Sn was applied in one other development. ELIN (A) and CERN had a joint project to construct a mirror magnet to test a single pole and a 1 m single aperture Nb<sub>3</sub>Sn dipole model magnet<sup>8</sup> which achieved a maximum quench field of 9.5 T. An impression of our twin aperture magnet is given in fig.2.



Fig. 2. Impression of the 11.5 T version of the twin aperture magnet which consists of 2 coil systems around both beam tubes each having a shrink fit collaring structure.

The volume around the beam pipe available for windings is very limited in the twin aperture concept which makes it essential to use high current density Nb<sub>3</sub>Sn. According to the reference design a field level of 10 T can be attained with a reasonable margin with conductors having a critical current density of about 1300 A/mm<sup>2</sup> at 11 T (≈1580 A/mm<sup>2</sup> at 10 T) in the non copper part. Here a copper part of at least 50 % to provide stability and a reliable quench behaviour as well as a strand-to-cable degradation was taken into account. Further demands exist regarding the spread in current density of less than 1 % and the filament size. In order to keep field errors due to filament magnetization at a low value, the diameter of the filaments should be below 10 μm. Unfortunately when we consider the properties of the available conductors as given in table 2 we come to the conclusion that the combination of a J<sub>c</sub>>1580 A/mm<sup>2</sup> at 10 T and D<sub>fil</sub><10 μm does not exist in the present state of the Nb<sub>3</sub>Sn wire development.

Bronze type of conductors have the advantage of being available on an industrial scale and they have fine filaments, but the wires are less performing in terms of the critical current density. The LHC specification can only be reached by reducing the amount of copper in the wire section to 25-30 % instead of 50-60 %. The first Nb<sub>3</sub>Sn LHC model magnet was made with the VAC material.<sup>8</sup> A field exceeding 10 T can be realized only when the volume of the windings is increased considerably by using a 4 layer coil.

Typical critical current densities J <sub>c</sub> (non Cu part) and effective filament size D <sub>fil</sub> in a few Nb <sub>3</sub> Sn wires of which a (small) production exists (approximate values taken from data sheets).		
manufacturer	J <sub>c nonCu</sub> [A/mm <sup>2</sup> ] at 10 T	D <sub>fil</sub> [μm]
VAC (1)	750-850	3-8
Hitachi (1)	800-850	3-8
Furukawa (1)	400-500	3-8
Sumitomo	700-800	3-8
IGC	800-1000	3-8
Showa (4)	1500-1600	45-75
TWCA (2) (1)	1400-1500	40-50
TWCA (3) (1)	700-800	10-15
ECN (5)	2000-2100	20-40

- (1) industrial fabrication exists of wires and cables,
- (2) wire optimized for high current density,
- (3) wire optimized for small filaments at moderate J<sub>c</sub>,
- (4) not available in large quantities, no cables,
- (5) production for special projects, including cables.

The best current densities in the range of 2000 to 2100 A/mm<sup>2</sup> at 10 T are found in the ECN powder method wire.<sup>12</sup> This wire is characterized by the use of Nb tubes with a core of NbSn<sub>2</sub> powder and a pure Cu matrix around the filaments is present to provide stabilization. The average current density in this type of wire is, with the same amount of stabilizing copper, about a factor of 2.5 more than with the bronze conductors. An important disadvantage is the filament size and further development at this point is essential. Wires with 36 and 192 filaments were made in a production quantity of about 500 kg and double-stack wires with up to 1332 filaments, which provides 10 μm filaments, have already been made on a



Fig. 3. Photograph of an LHC cable with ECN-type Nb<sub>3</sub>Sn wires; 36 strands of 0.90 mm diameter, 192 filaments, 55% Cu matrix. size = 1.45/1.77×16.40 mm.

laboratory scale.<sup>12</sup> Two prototype LHC cables made of the ECN material were tested recently.<sup>13</sup> A cross section of one of these is shown in figure 3. This cable for an outer coil has a critical current of 30 kA@8.7 T which is about 90 % beyond the nominal operating current. This goes far to proof the excellent performance of this type of conductor with respect to critical current density.

#### The 11.5 tesla design

A target field of 11.5 T using the best Nb<sub>3</sub>Sn conductor was the dominant aspect of the design process for a new conductor arrangement and collaring system. The basic structure around the collars which consists of a vertically split yoke and the outer shrinking cylinder is unchanged. A few parameters of the 11.5 T design are given in table 3.

Table 3. Main parameters of the 11.5 T magnet design.

target magnetic field	=	11.5	T
max. field in layer 1	=	11.9	T
max. field in layer 2	=	9.6	T
coil inner diameter	=	50	mm
coil outer diameter	=	130	mm
operating current (11.5 T)	=	17.7	kA
operating current (10 T)	=	15.4	kA
max. Lorentz forces:			
in x-direction	=	6.50	MN/m
in y-direction	=	-1.6	MN/m
on coil head	=	0.9	MN

**Conductor arrangement.** A new geometrical arrangement of the conductors in a 2 layer cos $\theta$  type of current distribution was generated by an optimization procedure as described elsewhere.<sup>15,16</sup> The selected lay-out as shown in figure 4 is based on a  $J_c$  of 1500 A/mm<sup>2</sup> at 10 T with a safety margin of about 20 %. The arrangement thus found for 11.5 T is optimal with respect to the amplitudes of the multipole components; the volume of superconductor by which the actual  $J_c(B)$  relation of a Nb<sub>3</sub>Sn conductor was included; the top angle of the first layer which should be as small as possible in order to have the maximum bending radius at the coil head; and the thickness of the cable in the first layer which automatically means a maximum possible number of strands in the outer layer cable. Note that the number of conductors in both layers is the same as in the reference design. On top of the second layer an additional copper spacer is present to obtain a single line interface between the coils and the insert.

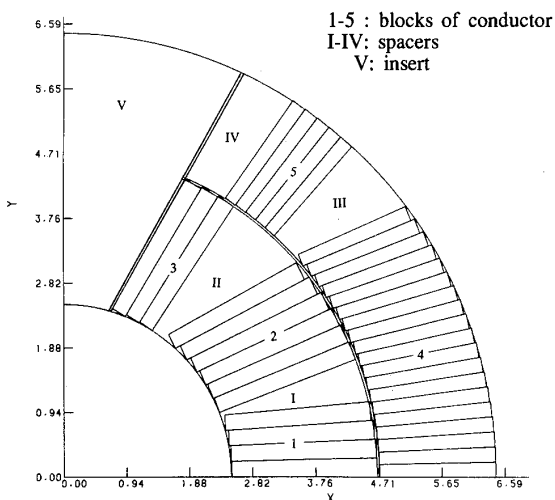

Fig. 4. The optimized conductor and spacer distribution providing 11.5 T with a  $J_c$  of 1500 A/mm<sup>2</sup> at 10 T.

Parameters of Nb <sub>3</sub> Sn cables for the inner and outer coils (I) Nb <sub>3</sub> Sn reference design for 10 T; (II) design for 11.5 T					
layer	[-]	(I) 10 T ref.		(II) 11.5 T design	
		first	second	first	second
thin edge size	[mm]	2.19	1.47	1.98	1.54
tick edge size	[mm]	2.69	1.79	2.47	1.93
bare width	[mm]	16.8	16.8	21.7	17.4
strand diam.	[mm]	1.35	0.99	1.26	0.98
percentage Cu	[%]	50	50	55	55
number strands	[-]	24	36	34	35
RRR value	[-]	≥100	≥100	≥100	≥100
cable pitch	[mm]	≤120	≤120	150	150
cable length	[m]	4×25	4×40	4×25	4×40
nominal current	[kA]	≈16@10.2T	≈8.7T	17.7@11.9T	≈9.6T
critical current	[kA]	≥17@11T	≥18@8.5T	20@12T	≈10T

**Superconducting cable.** The properties of the superconducting cables for both layers which belongs to the optimum arrangement are listed in table 4 in which also a comparison is made with the 10 T design. The widths of both cables is not the same and the total built-up in the radial direction has increased with 5 mm.

As part of the conductor developments the effect of transverse forces on keystoneed Rutherford Nb<sub>3</sub>Sn cables is studied.<sup>17</sup> The maximum stress transversely on the cable amounts to about 140 MPa in the medium plane of the first layer. From measurements on bare conductors we can expect a degradation of about 10 to 20 % at this stress level. To what extent these results are valid for insulated and fully impregnated cables is still uncertain. The first results give indication of a similar degree of degradation but more measurements to verify this have to be carried out.

The ECN and the TWCA conductors, see table 2, are at present the only candidates for the 11.5 T magnet. In fig. 5 the  $J_c(B)$  curves of both type of conductors are shown in relation to the load lines of both coil layers. The margins at 11.5 T of these conductors are 60 %, 15 and 10 % respectively. Taking into account a 30 %  $J_c$  reduction due to cabling and transverse compression of about 140 MPa, then still a margin of 10 % is present when using the ECN conductor. At this moment both conductors are in production.

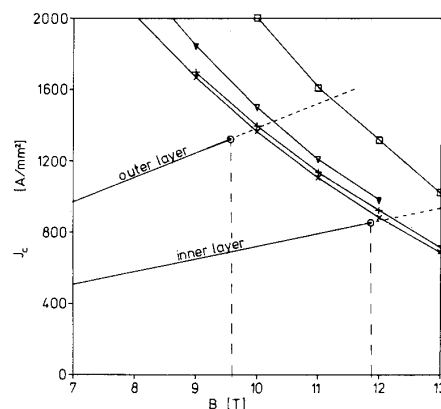

Fig. 5. Critical current density of the ECN, ECN-30% and 2 TWCA conductors, (□) 2000, (+) 1400, (x) 1500 and (∇) 1300 A/mm<sup>2</sup> at 10 T resp., in relation to the load lines of the inner and outer layers.

**Coil clamping structure.** The joint action of collars, yoke and outer cylinder has to take care of the Lorentz forces in such a way that the coil deformation is very small to reduce field errors and the coils have to remain under

compression in order to prevent premature quenches. The forces in the 11.5 T magnet were calculated using the 3-D FEM program TOSCA.<sup>18</sup> The main components are listed in table 3. The local forces in the windings are input for extensive ANSYS calculations to determine the details of construction.

In this magnet we will apply a shrinking collaring system which consists of rings of aluminum of 3 mm thickness stacked into a 1 m long cylinder. Further on, each of both coils in the twin aperture magnet will have its own collaring structure after which both come together in the common yoke. This allows us to exchange coils and it simplifies the collaring procedure. Sufficient pre-stress is obtained by a proper choice of the material of the insert which is in contact with the coil surface, and the precise dimensions of the inner diameter of the collar rings as well as the sizes of the insert. A short 10 cm model of a collared coil is now under construction, see figure 6. With this we can check

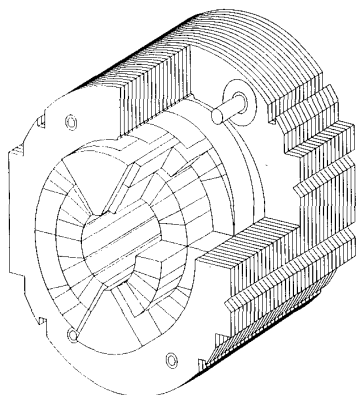

Fig. 6. View of the 10 cm model of one coil and its collars.

the ANSYS results and it enables the investigation of several inserts made of stainless steel or Molybdenum. In the short model pressure transducers are present to measure the actual pre-stress after collaring and cooling down. The stress level in the medium plane in the windings can go up to about 140 MPa at 11.5 T by which at the top angle still a net compression of 10-50 MPa remains.

#### Conclusions

An 11.5 T (10 T nominal) Nb<sub>3</sub>Sn dipole magnet is being designed and constructed. The application of ECN type of Nb<sub>3</sub>Sn wire could lead to the highest possible field in LHC type of dipole magnets due to its superior current density in comparison to other Nb<sub>3</sub>Sn materials. Both the ECN and TWCA type of conductors will be investigated. The current carrying capacity is sufficient to attain 11.5 T operation provided the mechanical structure and the conductor can handle the enhanced forces. The necessary preliminary work is almost completed, coil winding is scheduled for march 1991 and a first test of the magnet could occur in december 1991.

#### References

- Brianti, G., Hübner, K., "The Large Hadron Collider in the LEP-tunnel" *CERN report 87-5*, (1987).
- Brianti, G., The CERN LHC Working Group, "The Large Hadron Collider in the LEP-tunnel", *CERN LHC Note 123*, and *Proc. 2nd European Particle Acc. Conf.*, Nice, June (1990).
- Perin, R., The CERN LHC magnet team, "Progress on the superconducting magnets for the Large Hadron Collider", *IEEE Trans. on Magnetics*, MAG-24, (1988), 734-738.
- Perin, R., The CERN LHC magnet team, "First results of the high-field magnet development for the Large Hadron Collider", *Proc. MT-11 Tsukuba Japan 1989*, Ed. T. Sekingushi, S. Shimamoto, Elsevier Appl. Science, London, (1990) 42-47.
- Leroy, D., Perin, R., "Development of high-field superconducting magnets for the Large Hadron Collider", *Proc. 2nd European Particle Acc. Conf.*, Nice, June (1990).
- Hagedorn, D., Leroy, D., Perin, R., "Towards the development of high field superconducting magnets for hadron collider in the LEP tunnel", *Proc. MT9 Zurich Sept. 1985*, Ed. C. Marinucci, P. Weymuth, SIN Switzerland (1985) 86-91.
- Wenger, S., Zerobin, F., Asner, A., "Towards a 1 m long high field Nb<sub>3</sub>Sn dipole magnet of the ELIN-CERN collaboration for the LHC-project", *Proc. ASC 1988 San Francisco 1988*, *IEEE Trans. on Magnetics*, MAG-25 (1989) 1636-1639.
- Wenger, S., Zerobin, F., Asner, A., Perin, R., "First Nb<sub>3</sub>Sn, 1m long superconducting dipole model magnets for LHC break the 10 tesla field threshold", *Proc. MT-11 Tsukuba Japan 1989*, Ed. T. Sekingushi, S. Shimamoto, Elsevier Appl. Science, London, N.Y. (1990) 36-41.
- ten Kate, H.H.J., Daum, C., van de Klundert, L.J.M., Bode, H., Hoogland, W., Roeterdink, T.A., van Overbeeke, F., Perin, R., "On the development of a 1 meter "twin aperture" 10 T Nb<sub>3</sub>Sn dipole magnet for the CERN LHC", *Proc. IJSSC, New Orleans 1989*, Ed. M. McAshan, Plenum Press, N.Y., London (1989) 375-386.
- ten Kate, H.H.J., Daum, C., van de Klundert, L.J.M., Bode, H., Hoogland, W., Elen, J.D., van Overbeeke, F., Perin, R., "Development of a 10 T Nb<sub>3</sub>Sn twin aperture model dipole magnet for the CERN LHC", *Proc. MT-11 Tsukuba Japan 1989*, Ed. T. Sekingushi, S. Shimamoto, Elsevier Appl. Science, London, N.Y. (1990) 66-71.
- ten Kate, H.H.J., den Ouden, A., ter Avest, D., Wessel, S., van Emden, W., Daum, C., Bona, M., Leroy, D., Perin, R., "Development of a 10 T Nb<sub>3</sub>Sn twin aperture model dipole magnet for the CERN LHC", *Proc. 2nd European Particle Acc. Conf., EPAC-2, Nice, June (1990)*.
- Hornsveld, E.M., Elen, J.D., van Beijnen L.A.M., Hoogendam, P., "Development of ECN-type Niobium-tin wire towards smaller filament size", *Proc. ICMC 1986, Adv. in Cryog. Eng.*, vol. 34, (1987) 493.
- ten Kate, H.H.J., ten Haken, B., Wessel, S., "Long sample critical current measurements of Nb<sub>3</sub>Sn cables up to 50 kA at 11T", *Proc. ASC90 Snowmass, paper LHP29* 1990.
- ter Avest, D., Solutions of dipole field optimization using conductors with a rectangular cross section. *Internal report 6LHC890420, UT-ASC*, april 1989.
- ter Avest, D., ten Kate, H.H.J., van de Klundert, L.J.M., "Optimizing the conductor dimensions for a 10-13 T sc. dipole magnet", *Proc. ASC90 Snowmass, paper LCP31*, 1990.
- ten Kate, H. H. J., ten Haken, B., Wessel, S., Roeterdink, T.A., Hornsveld, E.M., "Critical current measurement of prototype cables for the CERN LHC up to 50 kA and 13 T using a single step superconducting rectifier", *Proc. MT-11 Tsukuba Japan 1989*, Ed. T. Sekingushi, S. Shimamoto, Elsevier Appl. Science, London, N.Y. (1990) 60-65.
- Boschman, H., Verweij, A.P., ten Kate, H.H.J., van de Klundert, L.J.M., "The effect of transverse loads up to 300 MPa at 11 T on the critical current of Nb<sub>3</sub>Sn cables", *Proc. ASC Snowmass USA sept. 1990, paper LHP 26* (1990).
- ter Avest, D., Daum C. and ten Kate, H.H.J., "Magnetic field and lorentz forces in an LHC-dipole magnet. 3-D analysis using the FEM program TOSCA", *Proc. MT-11 Tsukuba Japan 1989*, Ed. T. Sekingushi, S. Shimamoto, Elsevier Appl. Science, London, N.Y. (1990) 72-77.