

Development of Intelligent System for Visual Passenger Flows Simulation of Public Transport in Smart City Based on Neural Network

Yurii Matseliukh, Myroslava Bublyk and Victoria Vysotska

Lviv Polytechnic National University, S. Bandera Street, 12, Lviv, 79013, Ukraine

Abstract

Existing intelligent systems in passenger transportation are investigated, where the critical task is to evaluate passenger flows. Possibilities, accessibility, principles and principles of optimising intelligent passenger transportation systems of public transport in Smart City are analysed. It is established that the visualization of passenger flows is one of the critical tasks of optimizing routes and improving the quality of passenger transportation by public transport in Smart City. An intelligent system of visual simulation of passenger traffic is proposed, which, based on the neural network operation, allows optimising passenger transportation by public transport in Smart City.

Keywords 1

Passenger traffic, software product, public transport, visual simulation, neural network, passenger flow, Smart City, urban passenger transport, python programming language, information system, intelligent system, passenger service, passenger transport service, data processing

1. Introduction

Today, the problem of visual simulation of passenger traffic in the field of public transport in Smart City is essential in creating information systems for the development of modern cities. In the context of the fourth industrial revolution (Industry 4.0), it is crucial to develop tools and instruments for the implementation of a single self-regulatory system, which, in turn, will exchange data when providing relevant services. In our case, to provide passenger transportation services in the field of public transport in Smart City, which in turn are not sufficiently controlled by modern information systems.

The central and most important unit in public transport in Smart City is a passenger who needs urban or long-distance transportation. Many passengers who use public transport and perform the movements themselves with its help form passenger flows. Passenger flows may depend not only on the peculiarities of routes but also on specific main points of the largest passenger exchange in the city. Passenger traffic is the most critical aspect of creating new transport routes and connections, updating or changing existing ones. This problem of research and visualization of passenger flows has not been solved, which indicates the relevance of the topic.

The work aims to improve the quality of passenger transport services in public transport in Smart City. The following tasks that need to be solved follow from the set goal, namely:

1. To study and analyse modern and most well-known approaches, methods, tools and algorithms for solving problems of visual simulation of passenger flows.
2. Conduct a systematic analysis of the research problem; build a tree of goals was to determine the quantitative and qualitative criteria for assessing the degree of achievement of the overall goal.

COLINS-2021: 5th International Conference on Computational Linguistics and Intelligent Systems, April 22–23, 2021, Kharkiv, Ukraine
EMAIL: indeed.post@gmail.com (Y. Matseliukh); my.bublyk@gmail.com (M. Bublyk); victoria.a.vysotska@lpnu.ua (V. Vysotska)
ORCID: 0000-0002-1721-7703 (Y. Matseliukh); 0000-0003-2403-0784 (M. Bublyk); 0000-0001-6417-3689 (V. Vysotska)



© 2021 Copyright for this paper by its authors.

Use permitted under Creative Commons License Attribution 4.0 International (CC BY 4.0).

CEUR Workshop Proceedings (CEUR-WS.org)

3. To specify the functioning of the information system of visual simulation of passenger flows and build a hierarchy of tasks.
4. Choose software tools to solve this problem.
5. Create a description of the software product, develop user instructions, and check the operability on a control example.

The object of the study is passenger traffic in the field of public transport. The subject of the study is a visual simulation of passenger traffic in the field of public transport. The scientific novelty of the obtained results is given below:

- For the first time, a neural network with fully connected layers is proposed using an optimization algorithm with an adaptive level of Adam learning to predict the flow of passengers between stops for a certain period of the day.
- The composition of detailed data on passenger flows on urban routes has been improved, which, in contrast to the existing ones, includes general indicators of the ratio of passenger traffic at a certain stop to the current period of the day;
- Improved simulation model for calculating passenger traffic when changing the number of rolling stock on the route, where, in contrast to the known, added forecasting based on the developed neural network;
- The improved the mechanism of visual simulation, which, unlike existing ones, allows you to use an actual map and dynamic movement to control the simulation's speed.
- During the development of the information system, the approach of changing the capacity of public transport rolling stock in large cities was further developed, where, unlike the known ones, the change of capacity is limited by available vehicles and available staffing;
- The method of calculating a set of indicators of passenger traffic at stops and races, which, in contrast to the existing ones, considers other local phenomena of departure, exit to the route and lunch break, has further developed.

The practical significance of the information system of visual simulation of passenger flows in the field of public transport will allow:

1. Assess and visualize problem areas (races) on city routes.
2. Establish the main stops with the largest passenger exchange and the nodes with the most significant transfers.
3. Make an effective decision on the need to modernize the city's routes.
4. Predict changes in passenger flows when making adjustments to current transport routes in the city.

2. Analytical review of literary and other sources

2.1. Analytical review of reference

The problem of visual simulation is becoming increasingly important in the context of globalization. There is a growing need to build simulation models of the natural world, particularly for passenger traffic in the field of public transport. In [1, 2], a dynamic simulation model of passenger traffic distribution on transport networks is proposed, taking into account train schedules and delays, public transport of large and medium-sized cities, which is the basis for developing an algorithm for visual simulation of passenger traffic. Modelling, as a result, the authors of [1] form statistical indicators, including the volume of passenger traffic of each vehicle and stops, animated by the software product's means. The model proposed in [1] provides a quantitative example to illustrate the developed software.

It should be noted that the proposed approach [2] to model the actual performance of the solution, which focuses on the optimization of the theoretical objective function, contrary to the general optimization-simulation relationship, improves the objective function. This way of solving this problem, the authors justify the need to find good optimization options based on mathematical models, but improvement options lead to a more effective solution. The researchers built a link between the optimization of mathematical models and the actual positive effect of improving the objective function. To do this, illustrate this approach with numerous examples. The authors of [2] have developed a

software product that uses its mechanism of visual simulation and allows you to use an actual map and dynamic movement on it with the control of the speed of the simulation.

To improve the organization of passenger service on the route, the authors of [3] proposed to use a rational distribution of vehicles taking into account their passenger capacity during the day in which the transport is carried out. When using rolling stock with a small number of seats of the transport unit, in [3], it is taken into account that the increase in the number of such transport leads to congestion of the city transport network and increase excess emissions of harmful gases into the atmosphere. As a result of research, measures have also been developed to increase the efficiency of rolling stock to improve passenger service.

The paper [4] forms the basis of a simple theory of motion, which explains the origin and purpose of different types of travel in urban areas. The author first used the concept of frequency of travel, place of pilgrimage and method of travel. Based on traffic theory, the author made assumptions about the usefulness of estimating traffic volumes to assess the need for street models for newly built areas.

Some articles [5-7] are devoted to developing the methodology of obtaining, storing, and applying the results of the analysis of passenger flows to further its use in the planning of passenger traffic. The importance of integrating information systems of different types of urban passenger transport is considered in creating a secondary unified database of routes between adjacent stops, necessary for the implementation of an intelligent module for building optimal trajectories of passenger traffic.

It is essential to emphasize the approach considered in [8] to determine the capacity of higher transport areas for departure and arrival of passengers, which considers the magnitude of transit passenger flows through higher transport areas. The proposed approach requires a qualitative and skilled division of the city into transport areas. It is often complicated to implement due to the large size of cities, lack of accurate and objective information about the location of passenger centres, which the author calls places of employment and residence, and provides many examples.

An essential contribution of the authors of [7] is the study of the response of the motor transport system to changing passenger traffic, which is operational and forms a redundant set of inefficient models. The authors draw attention to the importance of applying the principles of traffic organization and highlight an important criterion: the quality of scheduled passenger transport by public transport. The main requirement of passengers is to minimize the time spent on one trip. It is proposed to consider the consistency of temporary characteristics of routes with places of stops taking into account the characteristics of passenger flows to be the key criterion for improving bus transportation.

As a result of research conducted in [9], scientists have developed an onboard software and hardware remote system for tracking public transport passengers, which allows you to record ultrasonic rangefinder readings on objects entering and leaving the door frame.

In [10], the author analyses scientific developments in information support for optimising public transport routes in large and huge cities and developed a method of obtaining a matrix of correspondence containing all types of urban movements to targets with precision to a specific stop. The identified goals and directions can be used to further research information support of optimization problems of networks of public passenger transport routes in large and vast cities.

According to the authors [11, 12], bus transportation efficiency in cities directly depends on a number of factors, including the effectiveness of the developed networks of transportation routes in large and huge cities. The study, as a result, marketing policies and measures were designed for the development of passenger traffic [11]. It was suggested that the use of rolling stock with a small number of seats should consider the dependence of increasing such transport, which leads to congestion and excess emissions into the atmosphere [12].

To predict passenger traffic in [13], the authors used the principle of a smart city to manage public transport, which was implemented using long-term memory (LSTM) based on the architecture of recurrent neural networks. The proposed hybrid optimized network model allows obtaining additional performance improvements by 4-20% compared to non-hybrid models. It indicates the feasibility of using the proposed hybrid optimized network LSTM based on Nesterov's accelerated adaptive moment estimation (Nadam) and Stochastic gradient algorithm when modelling passenger flows. The work [14] is devoted to a detailed review of scientific achievements in the construction of rational route networks of passenger transport. The authors of the article [15] consider the peculiarities of urban public transport logistics as one and the central node of passenger transportation and consider the existing rapid trend of urbanization and motorization. The model of the logistic system of public passenger

transport is offered in [15]. Its structural components and the principle of their interaction among themselves are reflected. Logistic streams and the purposes of their formation are allocated in the system. In [16], determining the type of attractiveness function of the passenger movement in the city for an unlimited number of options is considered, and the corresponding mathematical model is given.

The authors [17] conducted a study of passengers' choice of one of the available alternative routes from the initial to the final stop or the transfer stop, in case the travel conditions on different routes differ. It is essential to highlight the proposed generalized method of designing the route network of urban passenger transport. The researchers, as a result, stated in work [18], analysis of the demand for bicycle use is offered in a smart city based on machine learning.

The assessing the quality problem of passenger transport by public transport within the city with a different number of vehicles on the route is devoted to the work [19]. The authors analysed the existing methods of assessing the quality of urban transport and identified among the criteria quality indicators: pedestrian movement, waiting time, travel time and the dynamic coefficient of transport capacity.

The simulation model is developed in [19] changed the complex quality indicator of public transport in the city established a stable dependence of this indicator on the number of vehicles on the route and allowed to determine such a rational number of rolling stock that provides maximum efficiency of urban transport for the established quality level.

Some articles [20-28] are devoted to finding methods and ways to assess the quality of transport and developing a system of indicators of its effectiveness. The scientific work [29] analyses the legal and regulatory framework to determine the quality of passenger services. It identifies factors that affect the quality of these services, which outlines methods and ways to improve the quality of public transport.

The authors [23, 24] study the impact of globalization changes on human capital development and cite existing examples of declining global health, particularly the increase in cancer in women, due to increasing pollution from vehicle emissions. In scientific research [20, 22, 27], among the quality criteria are the following indicators: pedestrian movement, waiting time, travel time, dynamic coefficient of vehicle capacity, the minimum possible and actual values of travel time, time of the pedestrian component of traffic, number of transfers.

The paper [28] considers the need to develop specific and appropriate methodologies for assessing the quality of services, where special attention is paid to SP methods and discrete modelling of choice as a basis for estimating the SQI index.

Studies [25, 26, 30] outline the impact of transport systems on meeting people's needs by studying the behaviour, needs and expectations of passengers during travel, for which several authors [21, 30] use the SERVQUAL Model to assess public transport, as well as intercity bus transportation.

The SERVQUAL model contains five aspects, namely: reliability, confidence, sensitivity, empathy and sensitivity, which made it possible to establish a link between passenger satisfaction measures and objective measures of efficiency in public transport.

According to the results of research presented in [22], a stable dependence of complex indicators of passenger traffic in cities on the number of vehicles on the route and a structural scheme of quality indicators of passenger services, which can be used to transform activities, comprehensive assessment of service quality and rating of transport companies.

Multiple scales called "SERVQUAL" is developed by scientists in [21] to measure consumer perception of the quality of transport services in the field of public transport.

An essential component of public transport is the demand for these services, which is formed to provide quality services. The problem is considered from two points of view: the reaction of consumers of these services (passengers) and the attitude of employees who provide this service (drivers).

The authors of [31] consider the possibility of studying the change in the passenger's reaction while waiting for vehicles on the route network of urban passenger transport and propose the dependence of the description of such a reaction with a given accuracy.

In particular, the researcher in [32] considers the everyday world of professional drivers of city minibuses, which consists of routine practices in the context of labour and socio-economic relations. In her previous work [33], the researcher meticulously studies one of the elements of urban life - public transport and its users, who spend part of their lives in the vehicle, experiencing physical experience associated with the process of general travel. As a result of the research carried out in [34], the regularities of change of values of transport work of city passenger transport and an average distance of movement of passengers are defined. Also, the matrix dimension of passenger transportations on the

average length of passengers' movement within the city is calculated. The problem of organizing passenger transport by public transport is directly related to the management of the entire transport sector, which serves as an element of the social stability of the economic situation in the country.

The authors of scientific works [35-38] consider the role of public transport in solving the problems of modern cities, which are associated with a high level of motorization, congestion of the road network and poor environment. As the author of the work [38] points out, this problem has become especially acute, with the growth of air pollution due to emissions from the atmosphere and the unjustified increase in the public transport number. Providing urban passenger transport services is considered in [39], where the author discusses passenger transport, its accessibility, travel safety criteria, the attitude of the population to the transport service system and more. Several works [35, 36] are devoted to analysing the state and prospects of urban passenger transport. Thus, in [36] a set of measures aimed at improving the efficiency of urban passenger transport, an analysis of the dynamics of passenger traffic. The authors of the article [36] substantiate the need to increase public transport efficiency and identify a set of measures to improve public passenger transport's critical performance.

The authors of the scientific work [37] study the economic risks of transport companies and the features of risk management in the transport sector, highlighting the problems of management decisions in conditions of uncertainty and the analysis and evaluation of these risks.

Based on the research results conducted in [40], a method of developing measures for designing newly opened routes and improving the existing organization of transportation to improve the quality of passenger service and improve the use of rolling stock, reduce costs, save labour material resources.

It is worth emphasizing the new application of minimum total public costs per 1 passenger as a criterion for optimizing passenger traffic, proposed by the authors [41]. Researchers also suggest a structure of total public expenditures, which indicates that the share of the carrier's costs is many times less than the share of the expenses in the form of unearned general income.

Many scientific papers [42-47] highlight optimizing the network of urban passenger transport routes. Most of the mentioned authors use three main principles of the system approach: stratification, decomposition and targeting to build systems for optimizing the networks of public transport routes. The matrix of correspondence occupies a critical place.

In [45, 48, 49], methods of constructing a matrix of correspondence based on coupons, tables, electronic travel documents and with the help of special devices for fixing passengers, algorithms for restoring the matrix of equality of passenger traffic and its optimization to reduce total errors in passenger traffic distribution. MATLAB. There are two evolutionary methods for deriving the classical entropy model for calculating the correspondence matrix.

The approach to solving multi-criteria motor transport problems is described in [50], which was based on zoning on the principle of compliance with the hierarchical ratio of probabilities of possible environmental conditions. Researchers also substantiate the method of selecting a single equilibrium in the model of the equilibrium distribution of flows by paths when the balance is significant.

The authors of the research [43] determine the performance indicators of urban passenger transport for all participants in the system. In general, the target functions of the problem of optimization of urban passenger transport. They also describe the pain of transport routing and give its classical formulation and varieties of this problem. In the scientific work [51], the division of a big city into transport districts is investigated using correspondence matrices. The technique of distribution of transport loading for a big city is presented. The author shares the same opinion in [52], where he conducts a study of the division of administrative centres into transport areas by type of building and calculates the volume of arrivals and departures of passengers to transport regions by public transport.

The authors of [53], like most authors in previous articles, devoted their work to finding methods for optimizing route networks of urban passenger transport, which revealed the main features of optimization of route networks of urban passenger transport in modern science and software in this area. A group of authors [44] proposed a new model for optimizing the urban passenger transport system, which allows to consider the opposing interests of its participants and adapt the meta-heuristic algorithm of ant colonies to the task of designing route networks of public transport.

As a result of research presented in publications [54, 55], an optimization model for the bus network based on the road network was developed, aiming to achieve minimum traffic and maximum passenger traffic per unit length, with route length and nonlinear speed.

It is worth noting the key developments outlined in [46, 56], namely:

- Construction of a mathematical model for calculating the matrix of labour correspondence within the interval concept of modelling the demand for travel to cities,
- The method of finding intermediate states of the matrix of correspondence and the algorithm for calculating possible states [56] suburban services based on passenger capacity for departure and arrival of passengers at stops based on data obtained from electronic maps.

Researchers [57] are most interested in the field of bus passenger transport within the city, so they presented in their research a new approach to bus network design, which takes into account the main consequences of three of the four stages of the bus planning process.

The authors of [42, 58] created an optimized algorithm for solving vehicle routing problems, taking into account the number of vehicles and their clusters and developed ways to increase the attractiveness and eliminate the adverse effects of transport routes in cities. The work [59] is devoted to the definition of practical and new ways to stop transport shortcomings. The optimization of the route network and rolling stock on routes by vehicle capacity is proposed.

The methods of forming route networks of urban passenger transport developed in works [54, 60] represent results in the selected shortcomings of existing approaches and algorithms of creating a Smart city bus route network. The proposed optimization model for bus network design is based on the ant colony algorithm called CPACA (Coarse-grain Parallel Ant Colony Algorithm), aiming to maximize the number of direct passengers per unit length, i.e. the natural density of passenger traffic.

2.2. Analysis of existing software products

Opportunities for visualization of passenger flows in public transport in Smart City are provided by A + C Ukraine. As well as available three-month visualization of data on the sale of electronic tickets in the city of Zhytomyr on the website <http://texty.org.ua/> A + C Ukraine does not disclose its methods and concentrates on individual cities or routes, does not support international standards for the presentation of courses, and prefers to develop solutions in each unique situation. The company is more focused on organizing information collection than on the visual simulation of passenger traffic. The only example of this work presented by this company in the public domain is shown in Fig. 1.

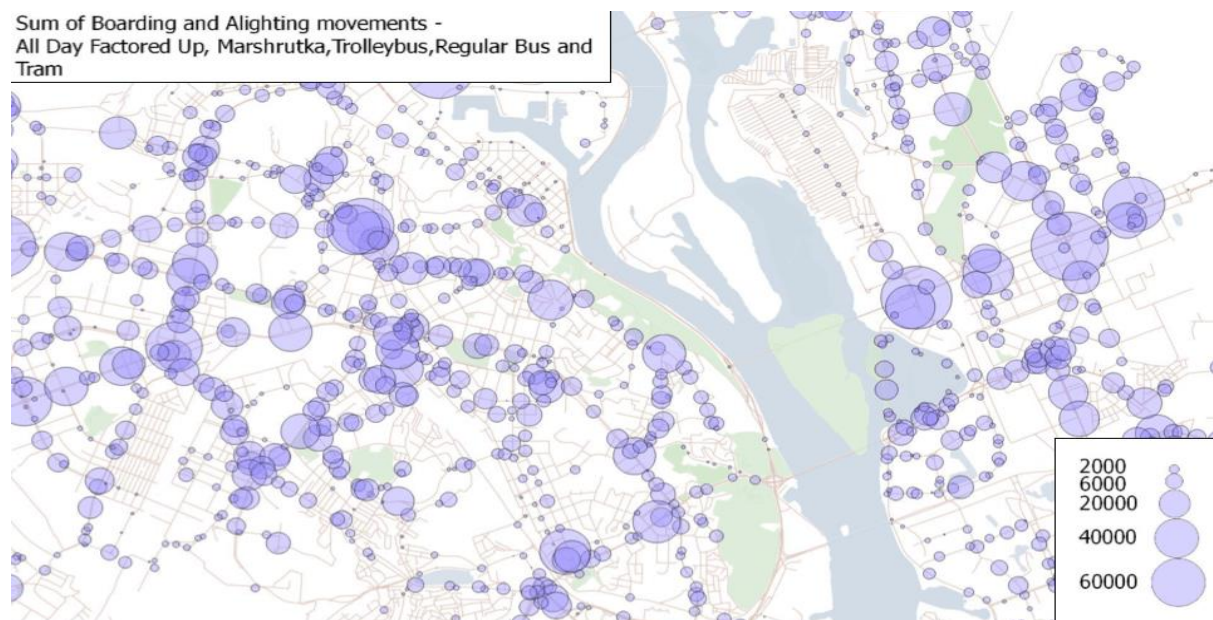

Figure 1: A + C Ukraine software product

Visualization of data from the electronic ticket on the site <http://texty.org.ua/> has not updated since January 2019. Currently, the site provides visualization of passenger traffic only for three months. It is worth noting that the data collected from the e-ticket is already partially distorted, as not all passengers buy a ticket immediately after entering the vehicle for various reasons. In addition, not all passengers, in general, buy a ticket. This system does not use data on actual passenger flows. Still, it provides only

a generalized schematic picture of paid tickets, not considering the current traffic load at the race. A screenshot of the site with the collected data for a given period is shown in Fig. 2.

Similar to the designed system are two products developed and presented by PTV Group, namely PTV Visum and PTV Vissim. One of these products is PTV Visum, created as software for traffic planning to design and plan transport routes to expand cities' capabilities. Another - PTV Vissim is designed according to modern requirements and is flexible software for modelling traffic in the city.

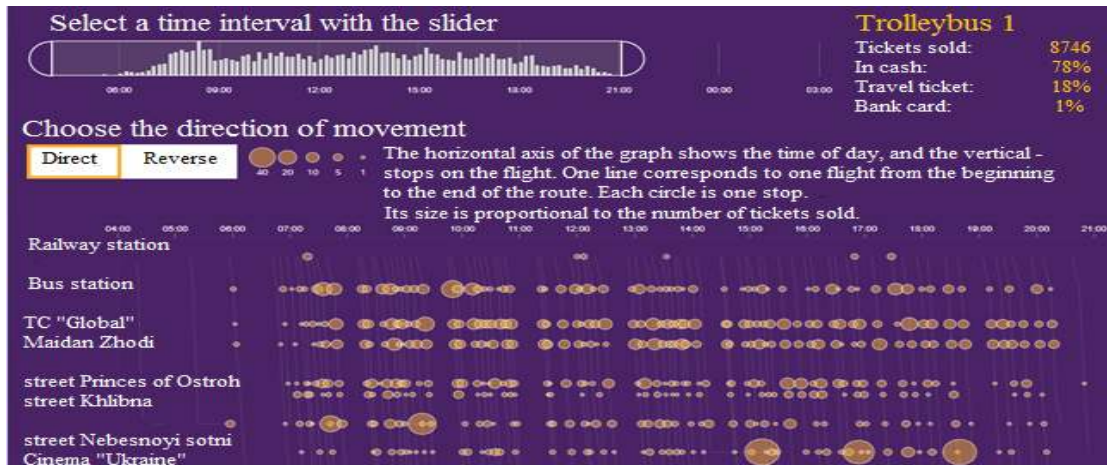

Figure 2: Website texty.org.ua

These software products have been on the market for over 40 years and have accumulated almost all known today methods of research and solution to transport problems of large cities. However, these software products have several disadvantages compared to the designed software: the programs do not have the Ukrainian language; there is no Ukrainian translation on the company's website.

As this product has become widespread and is used in more than 2.5 thousand cities worldwide, its price is indecently high. The estimated cost of access to the software product, research, optimization, which must be further studied and carried out by yourself, is almost 2 million UAH per 100 km of the transport network. To compare the scale, the usual trolleybus route in Lviv is 12 km. Therefore, although it provides very great opportunities, this program offers very significant opportunities. Still, for their implementation, you need to have a large amount of money and further learn from their books how, in general, to use this program. An example of the program interface is shown in Fig. 3.

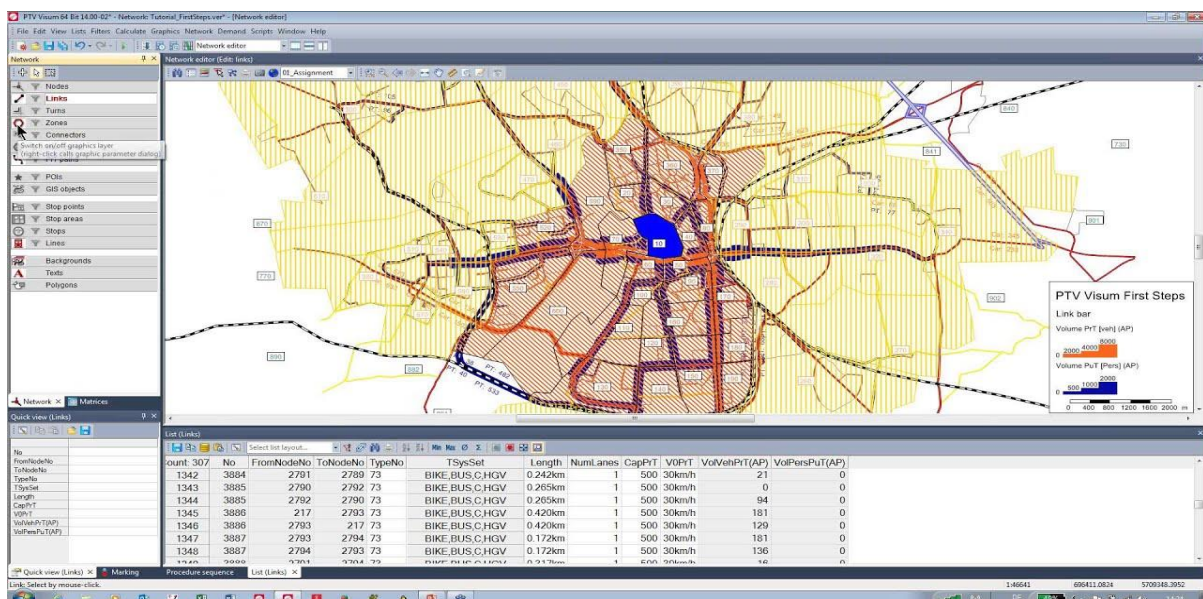

Figure 3: PTV Visum software product

It is the complete opposite of the philosophy implemented in the project of this work, namely, in a simple and intuitive interface. A comprehensive comparative analysis of similar products is given in Table 1.

Table 1
Comparative analysis of analogues present on the market

Features	A + C Ukraine	texty.org.ua	PTV Visum
Price	It is determined personally for each problem	Free	~UAH 2 million for 100 km
Language	Ukrainian	Ukrainian	Ukrainian is missing
Demo version	None	None	30 days with personal approval from the company
Product type	The company will do all the work for you	Website	Desktop program
Availability of documentation	None	None	Paid books
Number of cities	11	1	2500
Relevance of information	Carried out at your request	The latest data for January 2019	Constant
Type of visualization	3D	2D	2D and 3D
Use of neural networks	Unknown	None	None
Executor of work	Company	Not supported	Product user

Thus, improving the quality of passenger transport is directly related to passenger traffic in the field of public transportation in Smart City, namely their evaluation and analysis and, as a consequence, visual simulation. Currently, the problem is little studied among available information systems. Based on the comparison given above, it can be understood that some products are either costly and provide excellent opportunities for data processing and integration from different sources [61-76], but at the same time are incomprehensible to the user and require a lot of effort to study the documentation. Other products are only companies that provide passenger traffic research services, i.e. the user does not need to do anything, but at the same time, it costs a lot of money. Alternatively, completely free in the third case, but which cannot be used because they are designed purely for one city and one type of data. In addition, just provide a general understanding of the site, and this information is relevant for January 2019. Given the current needs in the study and visual simulation of passenger traffic, this area requires new approaches to solving, which determines the relevance of the task.

3. System analysis of the research object

3.1. Analysis of existing software products

The object of study of this work is passenger flows in public transport in Smart City. The general purpose of its operation was formed to comprehensively outline the essence of the system under investigation, namely: "Carry out a visual simulation of passenger traffic on public transport routes." The tree of goals with the primary goal, aspects of the system's main goal, and quality criteria for the system's functioning are shown in Fig. 4. Characteristics of the main goal include "Construction of dynamic and static simulation models of routes" and "Application of mathematical models". Each element has its criteria for the quality of the system. The first aspect includes the following criteria: Support for the GTFS standard, Integration with Excel spreadsheets, and Intuitive interface intelligibility. The second aspect is met by the following criteria: "Opportunity for self-study" and "Implementation of forecasting". For the designed system, three alternative options for its construction have identified, namely: "Intelligent System", "Search Information System" and "Reference

Information System". Using the method of analytical hierarchy, using the tree of goals and many alternatives, the selection of the best option for building the designed system is given below.

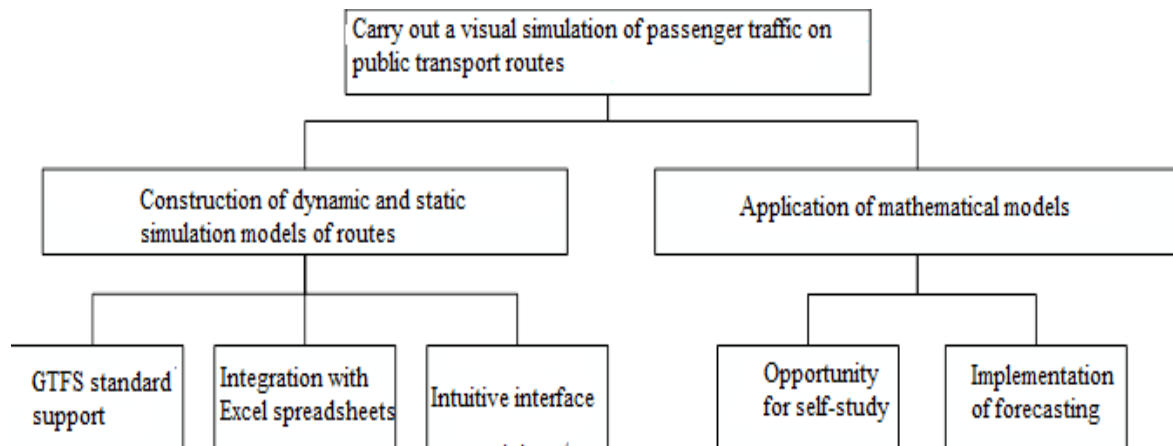

Figure 4: Objectives tree

For the implementation of this system method, the general goal is defined: "Choose the type of system for design", which also sets two factors: "Interaction with data" (F1) and "Working with models" (F2). The first factor includes the following criteria: "Support for the GTFS standard" (K1), "Integration with Excel spreadsheets" (K2) and "Intuitive interface intelligibility" (K3). The second criterion is the following criteria: "Opportunity for self-learning" (K4) and "Forecasting" (K5). The following alternative system construction options are generated: "Intelligent system" (A1), "Search information system" (A2) and "Reference information system" (A3). Fig. 5 shows a graphical representation of a hierarchical system of factors, criteria and alternatives.

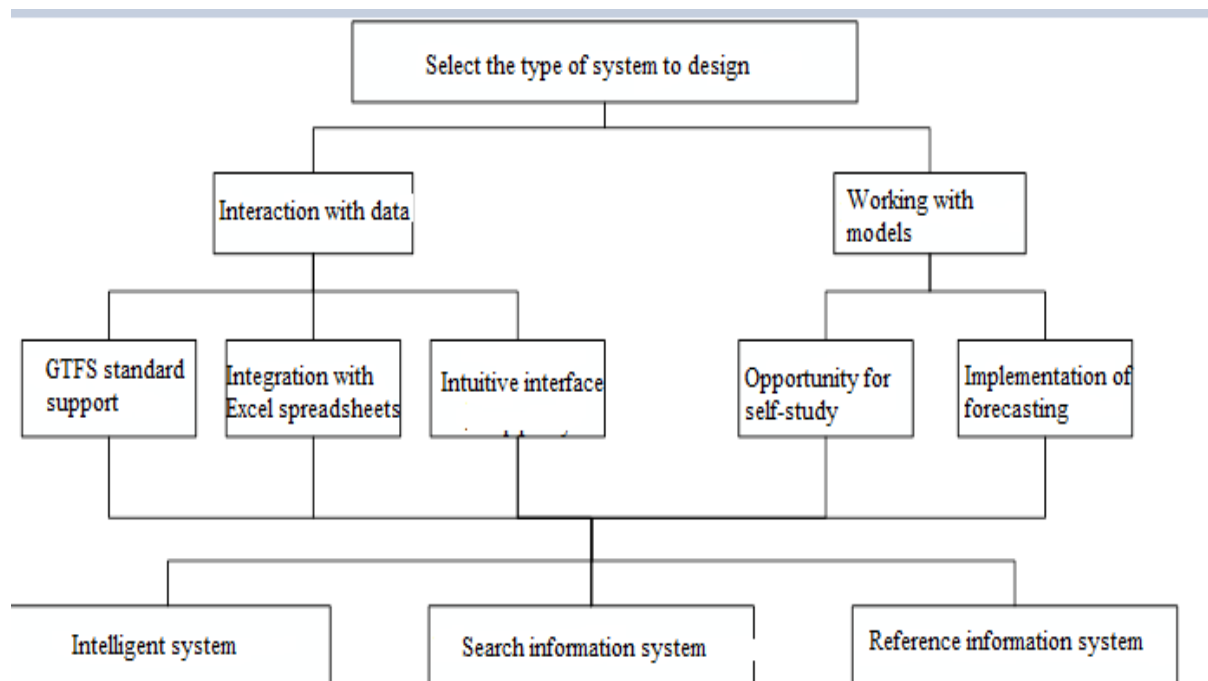

Figure 5: Hierarchy of criteria and alternatives of system types

Now the task is to find the best alternative to the type of designed system among the set of alternatives A1-A3.

Matrices of pairwise comparisons using the method of pairwise comparisons of elements of the hierarchy are constructed. These matrices indicate the influence of each of the criteria on the optimal choice of the designed system type. For each matrix, the eigenvalue of the matrix λ_{max} is calculated according to formulas (1), (2) and the eigenvalue of priorities.

$$\lambda_{max} = R_1 \sum_{i=1}^n W_{i1} + R_2 \sum_{i=1}^n W_{i2} + \dots + R_i \sum_{i=1}^n W_{in} \quad (1)$$

$$R = \sqrt[n]{\prod_{j=1}^n W_{ij}} \times \left(\sum_{i=1}^n \sqrt[n]{\prod_{j=1}^n W_{ij}} \right)^{-1} \quad (2)$$

The matrix M1, which is given in Table 2, indicates that F2 has the most significant influence. For each factor, the own matrix of the impact of criteria on this factor is constructed in Table 3, Table 4. Matrices of pairwise comparisons of alternatives are given in Table 5 – Table 9.

Table 2

Matrix M1

M1	F1	F2	W1
F1	1	1/2	0.447
F2	2	1	0.894

$\lambda_{max} = 2.0$

Table 3

Matrix M2

M2	K1	K2	K3	W2
K1	1	2	1	0.667
K2	1/2	1	1/2	0.333
K3	1	2	1	0.667

$\lambda_{max} = 3.0$

Table 4

Matrix M3

M3	K4	K5	W3
K4	1	2	0.894
K5	1/2	1	0.447

$\lambda_{max} = 2.0$

Table 5

Matrix K1

K1	A1	A2	A3	W4
A1	1	2	4	0.900
A2	1/2	1	2	0.600
A3	1/4	1/2	1	0.300

$\lambda_{max} = 3.0$

Table 6

Matrix K2

K2	A1	A2	A3	W5
A1	1	2	1	0.667
A2	1/2	1	1/2	0.333

A3	1	2	1	0.667
----	---	---	---	-------

$\lambda_{\max} = 3.0$

Table 7
Matrix K3

K3	A1	A2	A3	W6
A1	1	4	3	0.788
A2	1/4	1	3	0.491
A3	1/3	1/3	1	0.245

$\lambda_{\max} = 3.21$

Table 8
Matrix K4

K4	A1	A2	A3	W7
A1	1	5	5	0.574
A2	1/5	1	1	0.115
A3	1/5	1	1	0.115

$\lambda_{\max} = 3.0$

Table 9
Matrix K5

K5	A1	A2	A3	W8
A1	1	2	2	0.788
A2	1/2	1	2	0.491
A3	1/2	1/2	1	0.245

$\lambda_{\max} = 3.05$

Similarly, the priority vector of alternatives to hierarchical factors was determined, namely the priority vector to F1 (W_{F1}^A) according to the formula (3).

$$W_{F1}^A = [W4, W5, W6] \times W2 \quad (3)$$

According to formula (3), the values of the priority vector are calculated W_{F1}^A .

$$W_{F1}^A = \begin{bmatrix} 0,9 & 0,667 & 0,788 \\ 0,6 & 0,333 & 0,491 \\ 0,3 & 0,667 & 0,245 \end{bmatrix} \times \begin{bmatrix} 0,667 \\ 0,333 \\ 0,667 \end{bmatrix} = \begin{bmatrix} 1,348 \\ 0,838 \\ 0,585 \end{bmatrix}.$$

Priority vector relative to F1 (W_{F2}^A) according to the formula (4).

$$W_{F2}^A = [W7, W8] \times W3 \quad (4)$$

According to formula (4), the values of the priority vector are calculated W_{F2}^A .

$$W_{F2}^A = \begin{bmatrix} 0,574 & 0,788 \\ 0,115 & 0,491 \\ 0,115 & 0,245 \end{bmatrix} \times \begin{bmatrix} 0,894 \\ 0,447 \end{bmatrix} = \begin{bmatrix} 0,865 \\ 0,322 \\ 0,212 \end{bmatrix}.$$

Priority vector relative to the focus of the hierarchy (W_{Φ}^A) is calculated by (5).

$$W_{\Phi}^A = [W_{F1}^A, W_{F2}^A] \times W1 \quad (5)$$

According to formula (5), the values of the priority vector are calculated W_{Φ}^A .

$$W_{\Phi}^A = \begin{bmatrix} 1,348 & 0,865 \\ 0,838 & 0,322 \\ 0,585 & 0,212 \end{bmatrix} \times \begin{bmatrix} 0,447 \\ 0,894 \end{bmatrix} = \begin{bmatrix} 1,375 \\ 0,662 \\ 0,451 \end{bmatrix}.$$

The resulting vectors of priorities of alternatives for the considered hierarchy and its values are given in Table 10. Therefore, as shown in Table 10, the best option for building the designed system was the alternative A1 "Intelligent System".

Table 10

Values of the priority vector

Alternative	The value of the vector element	Priority
A1 – Intelligent system	1,375	1
A2 - Search information system	0,662	2
A3 - Reference information system	0,451	3

3.2. Concretization of system functioning

It is detailed the structure of the information system using the structural methodology and its specific implementation in the form of functional diagrams IDEF0. The context diagram showing the system's primary process (function) is shown in Fig. 6. By decomposition, a hierarchy of methods (parts) of lower levels is constructed, shown in Fig. 7 - Fig. 11.

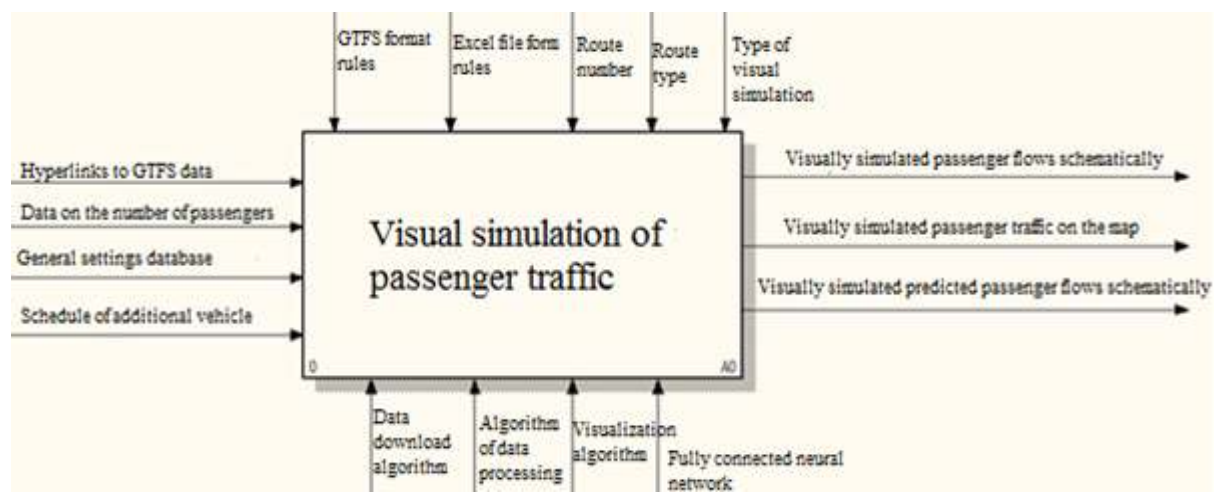

Figure 6: Context diagram

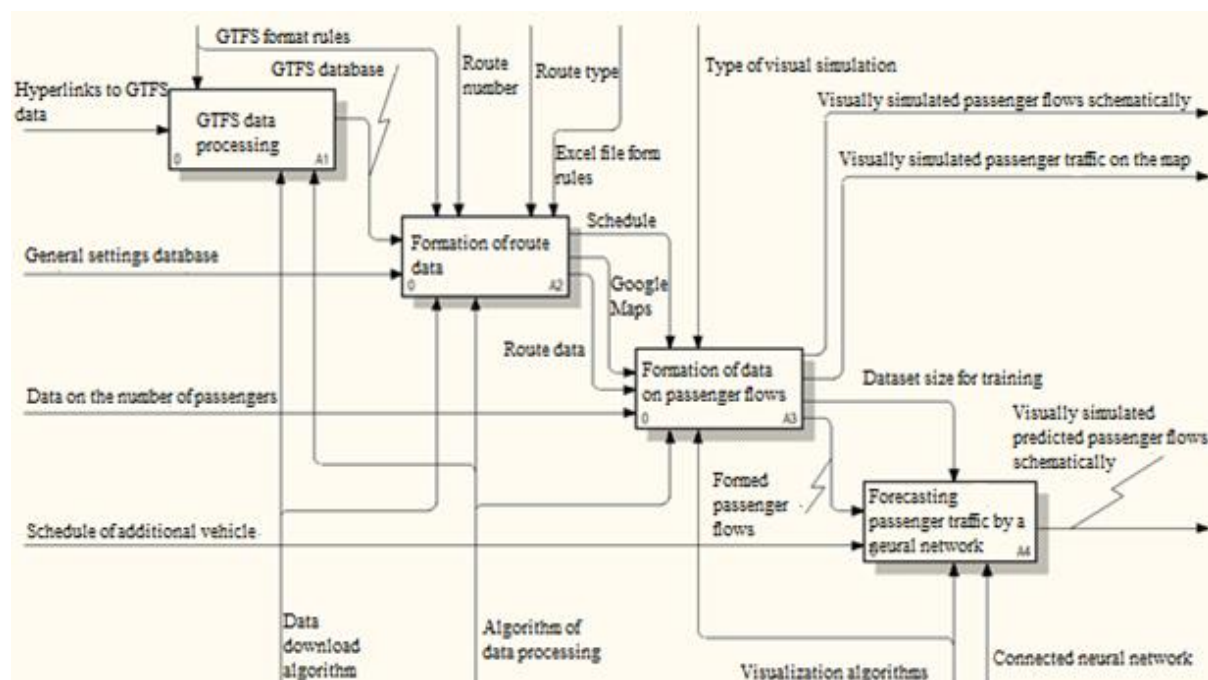

Figure 7: Decomposition of context diagrams

The disintegration of the context diagram is shown in Fig. 7. This decomposition consists of 4 functional blocks: "GTFS data processing", "Route data generation", "Passenger traffic data generation", and "Neural network passenger traffic forecasting" by Machine Learning technology base on Based on Neural Network Approach [77-85]. Between these blocks, information is transmitted between outputs and inputs, and process control takes place. The decomposition of the functional unit "GTFS data processing" is shown in Fig. 8. This available diagram consists of more refined processes: "Downloading GTFS data" and "Filling GTFS with database data".

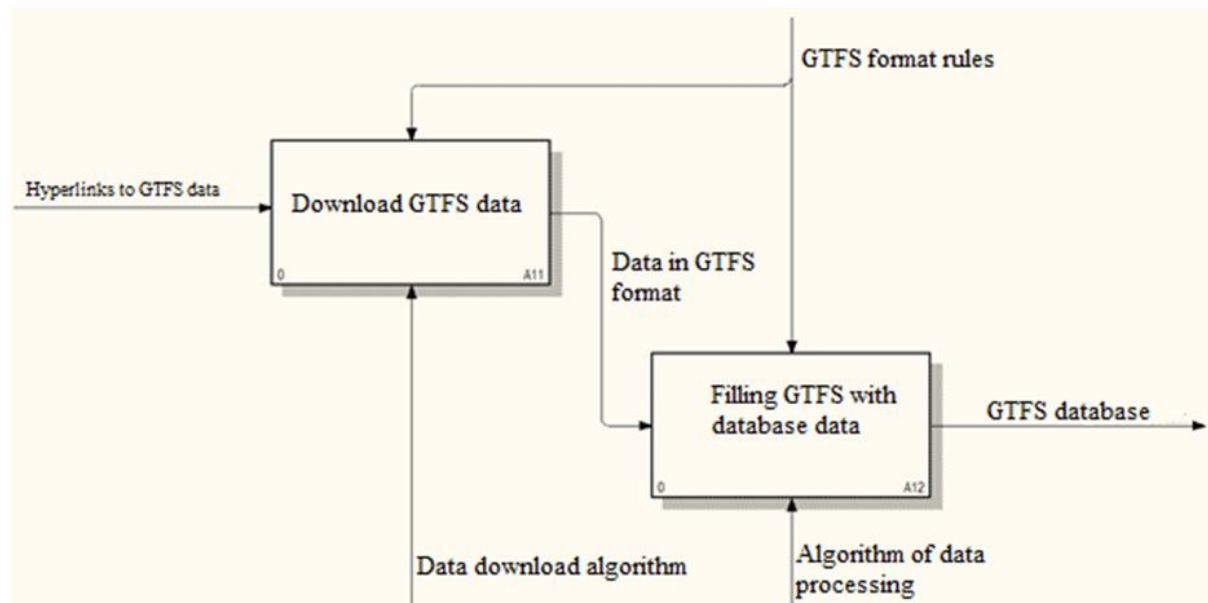

Figure 8: Decomposition of the functional unit "GTFS data processing"

Decomposition was carried out and the following process called "Formation of route data", which is shown in Fig. 9. The pollution consists of the subsequent four blocks: "Download Google Maps", "Accelerate data loading", "Create an Excel file to fill", and "Create an additional vehicle file".

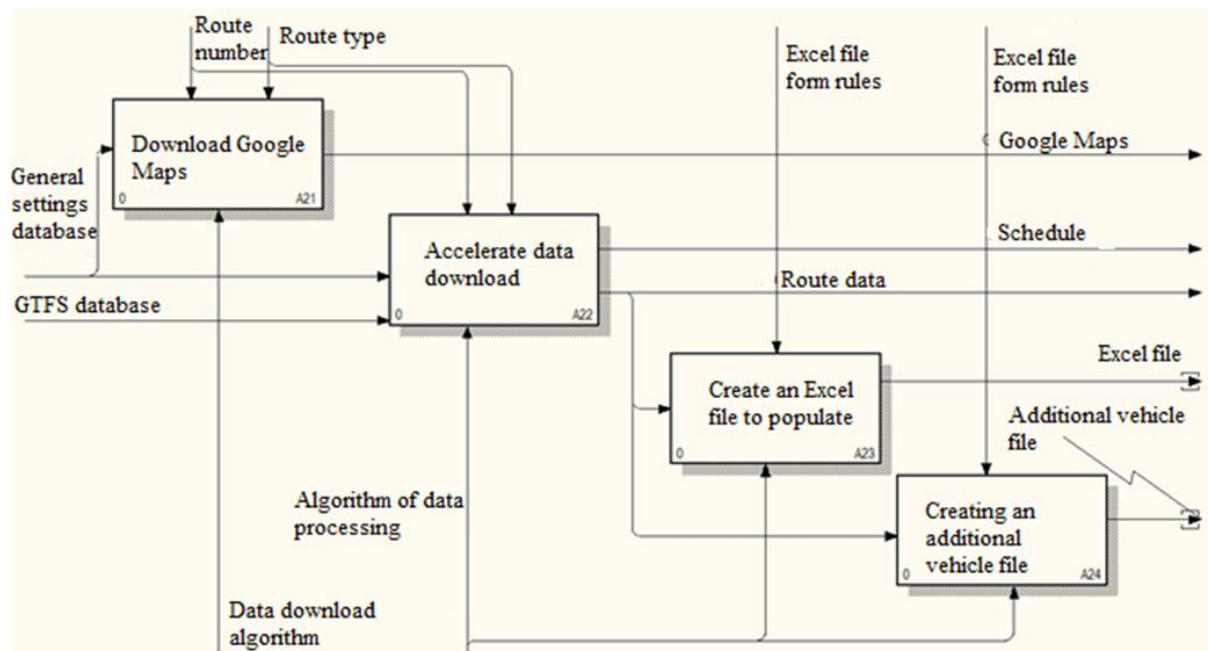

Figure 9: Decomposition of the block "Formation of route data"

The following functional unit for which the decomposition is successfully carried out is "Formation of data on passenger flows". This decomposition consists of the following processes: "Formation of the

schedule with passenger flows", "Creation of hourly passenger flows", and "Creation of the schedule of transport stops". This functional diagram is shown in Fig. 10. The last available block, over which the decomposition is carried out, is "Forecasting passenger traffic by a neural network". In turn, the disintegration of this block consists of three processes, namely: "Neural network learning", "Neural network preservation" and "Calculation of new passenger flows" by Objective Clustering Inductive Technology and Bayesian methods [86-91]. This functional diagram is shown in Fig. 11.

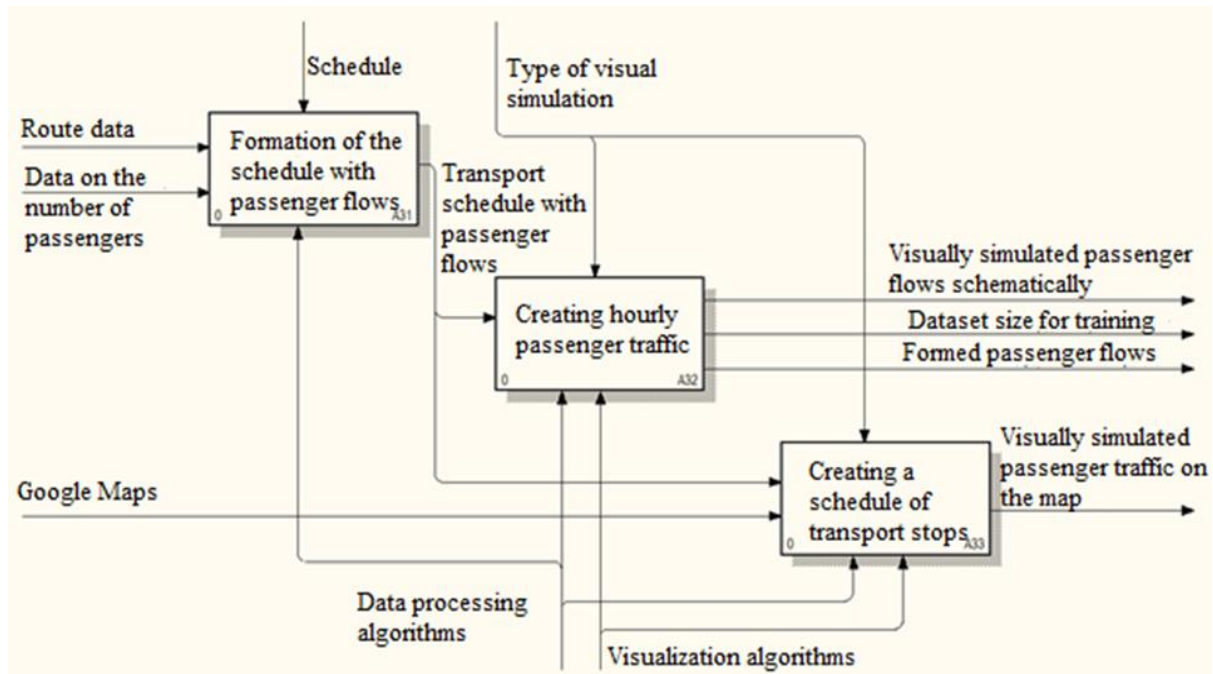

Figure 10: Decomposition of the block "Formation of data on passenger traffic"

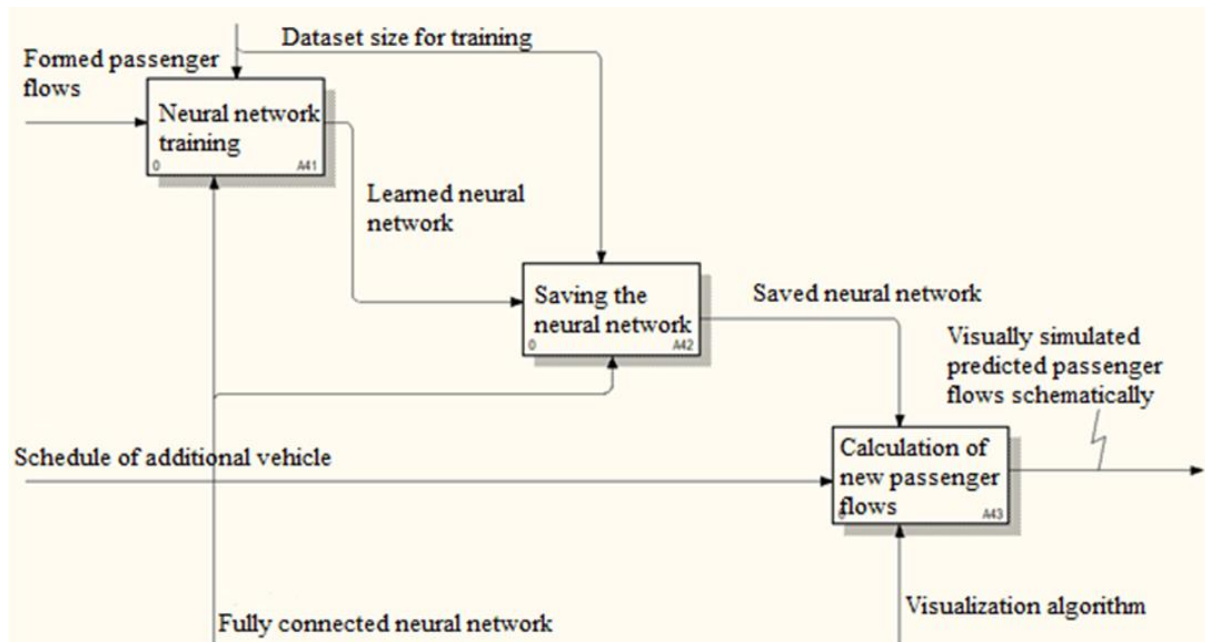

Figure 11: Decomposition "Forecasting passenger traffic by neural network"

For this information system, further concretization is performed using Workflow (IDEF3) diagrams. All IDEF3 diagrams are shown in Fig. 12-Fig. 23. The specification of the process "Download GTFS data" is presented in Fig. 12. This diagram consists of the "Download validation" block, two parallel to the "Download progressive update" and "Save files" blocks, and the last "File integrity check" block, where you check whether all bits of the file are correctly transferred and stored on user disk.

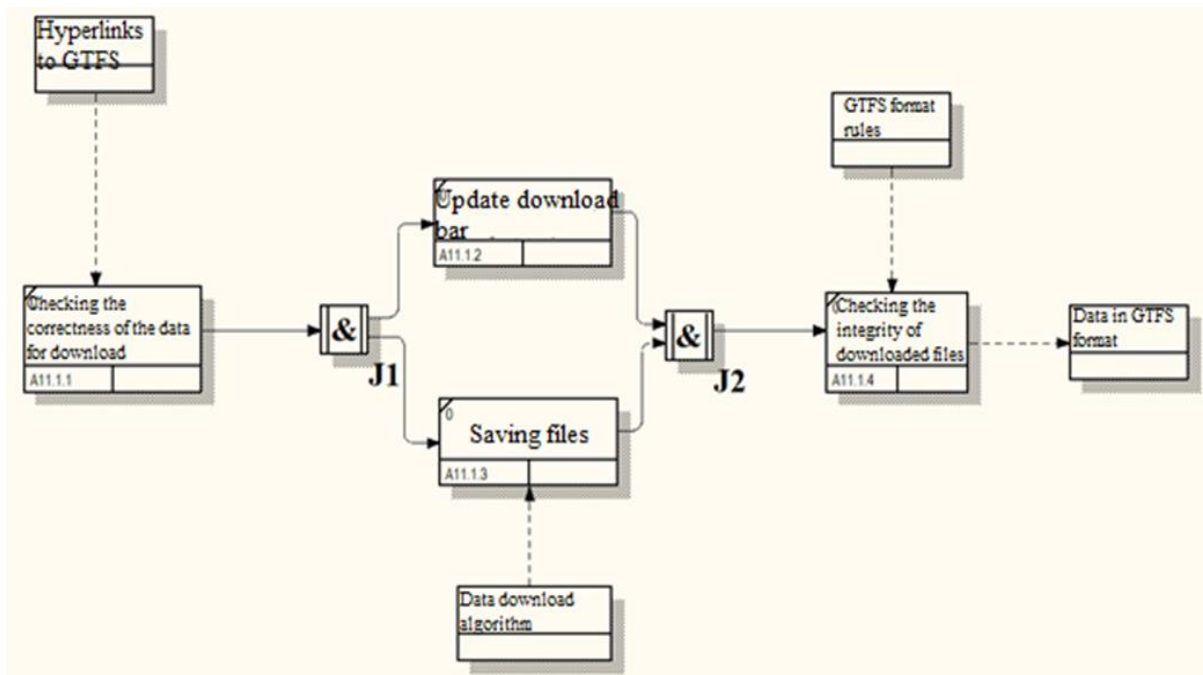

Figure 12: Decomposition of the GTFS Data Scanning unit

Next, for a more detailed specification of the processes, the decomposition of the block "Filling GTFS with database data" is performed, which is shown in Fig. 13.

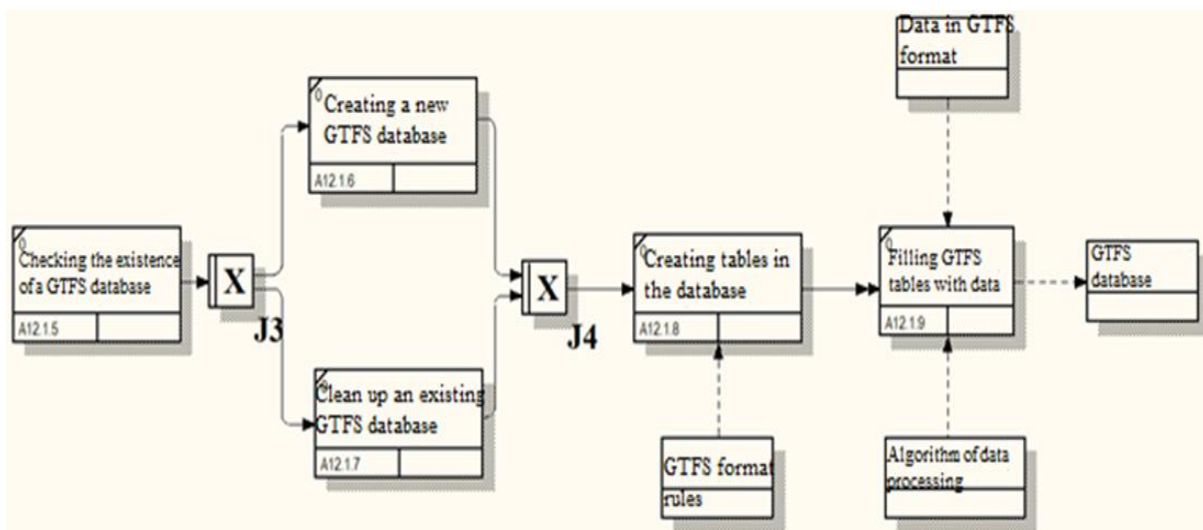

Figure 13: Decomposition of the block "Filling GTFS with database data"

The diagram consists of the process "Checking the existence of a GTFS database", performing one of two processes, or "Creating a new GTFS database", or "Cleaning an existing GTFS database". The process «Creating tables in the database «and» Filling GTFS tables with data follows this. The process of "Downloading Google Maps" consists of the process of "Checking the availability of maps", after which you will immediately go to the process of "Checking the integrity of maps" or to "Create a hierarchy for storage". After that, two parallel processes "Update the map download progressive" and "Save maps" will be launched, where after the completion of these two processes there will be a transition to the process "Check the integrity of maps", which was mentioned above. This IDEF3 diagram is shown in Fig. 14. During the decomposition of the "Map Download Acceleration" block, the following three processes are defined, which are performed sequentially: "Preparation of GTFS data", "Generation of data on the selected route" and "Determination of the schedule for the route". This diagram is shown below in Fig.15. To decompose the process "Creating an Excel file to fill" used two

processes: "Creating an Excel file template" and "Filling Excel file data", which are presented in Fig. 16. If we talk about the decomposition of the block "Creating a file of an additional vehicle", then there is also a division into two processes, namely: "Creating a file" and "Filling the file template according to the rules." This decomposition is presented in the diagram shown in Fig. 17. To perform the decomposition of the process "Formation of the schedule with passenger flows", which is shown in Fig. 18, three concretizing processes are defined: "Creating a stop schedule", "Filling the stop schedule" and "Checking the correctness of the completed schedule". Regarding the process of "Creating hourly passenger traffic", it can be divided into the process of "Generation of schedule data for passenger traffic", after which two processes take place in parallel: "Determining the size of the dataset" and "Calculating passenger traffic".

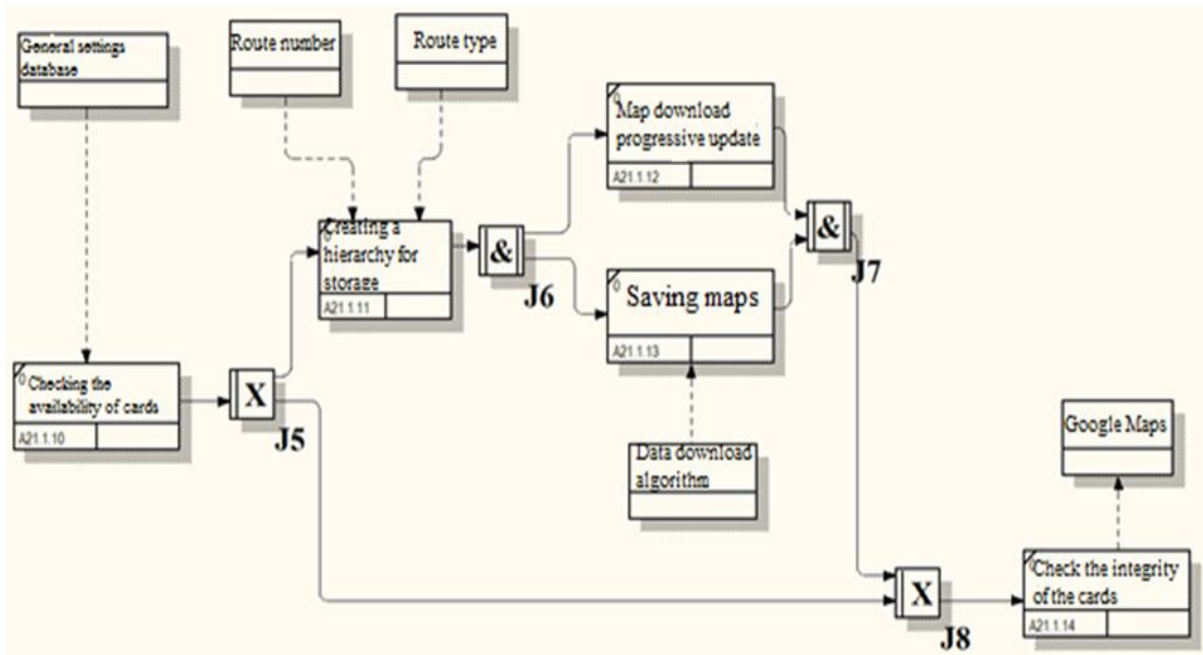

Figure 14: Google Maps Download Decomposition

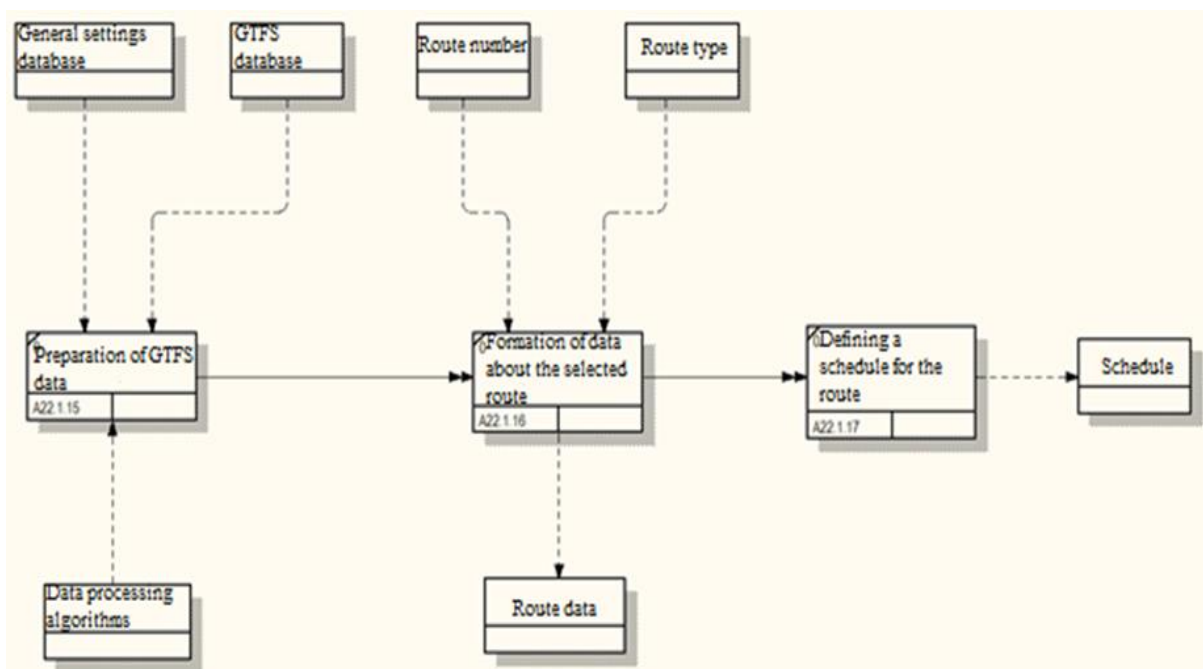

Figure 15: Decomposition of the "Accelerate map loading" block

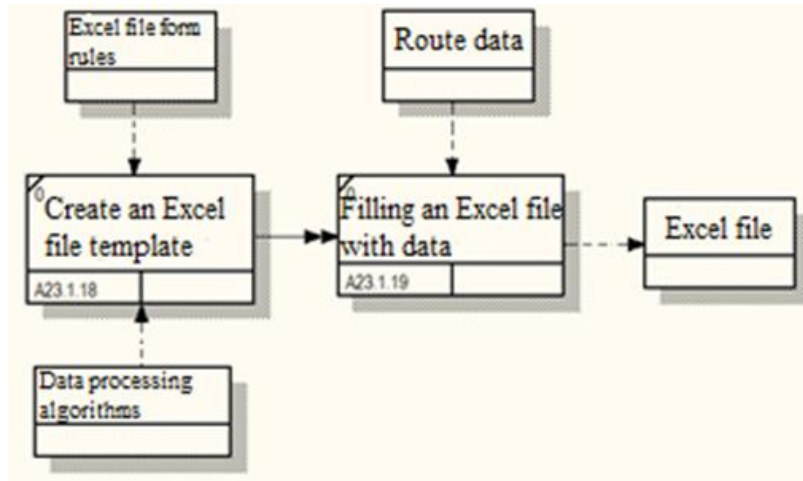

Figure 16: Decomposition of the block "Creating an Excel file to fill"

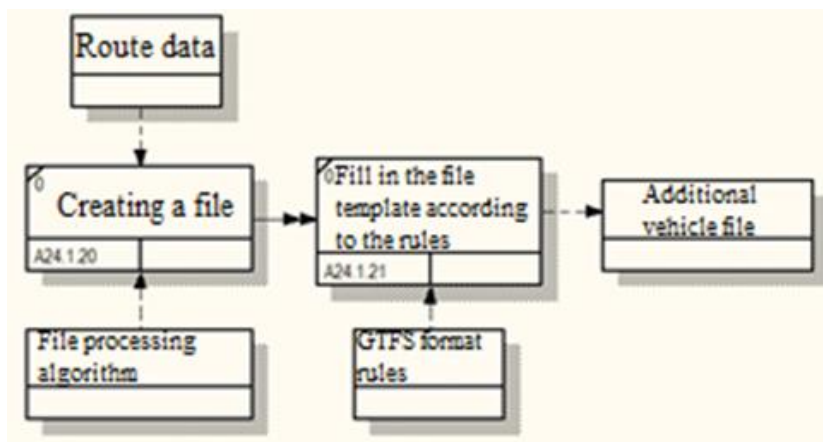

Figure 17: Decomposition "Creation of an additional vehicle file"

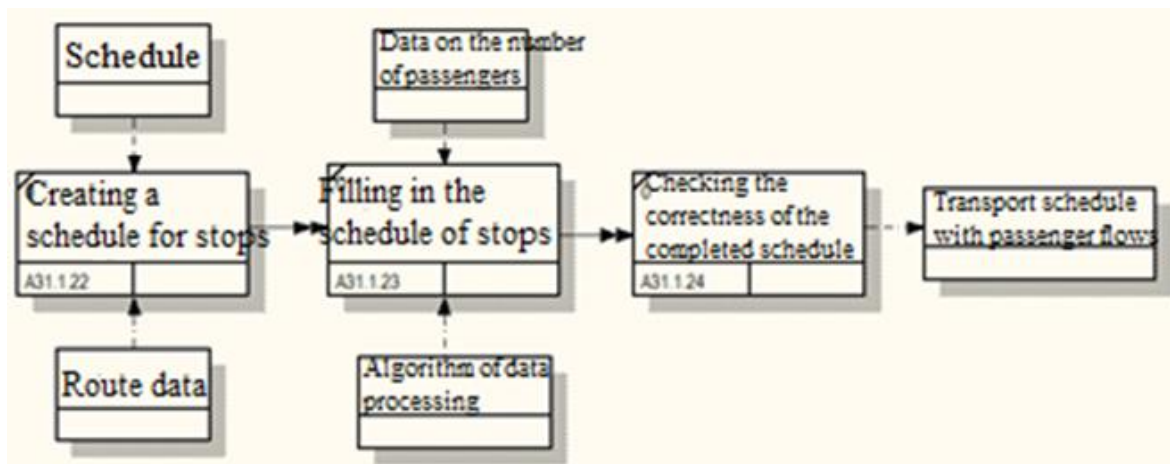

Figure 18: Decomposition of the block "Formation of the schedule with passenger flows"

Successful completion of these two parallel tasks allows you to start the process of "Determining the type of visual simulation", followed by the block "Starting a visual simulation". More detailed decomposition of the above-mentioned functional block is shown in Fig. 19. The following function block, "Creating a schedule of transport stops", was successfully refined using the processes: "Data generation for visual simulation", "Reading the type of visual simulation", "Overlay map", and "Start visual simulation on the map", the general view of which is shown in Fig. 20. The process of "Learning the neural network", on which the decomposition was performed, is shown in Fig. 21.

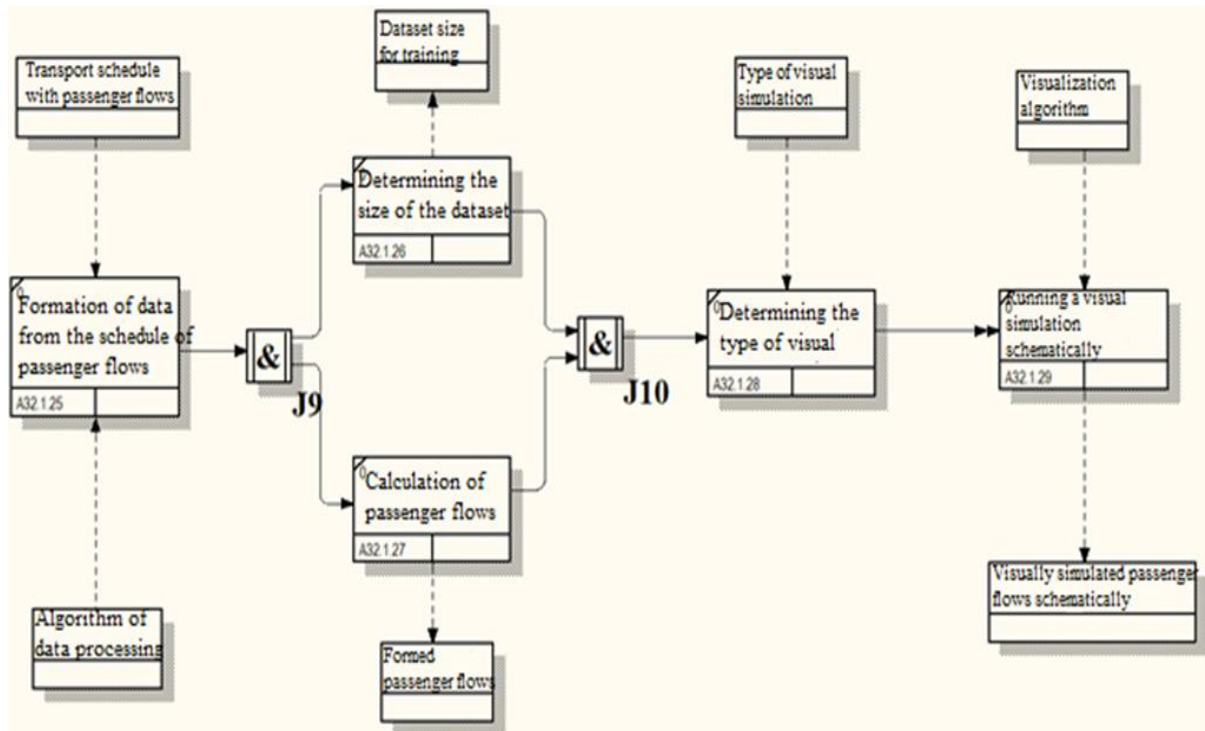

Figure 19: Decomposition of the block "Creation of hourly passenger flows"

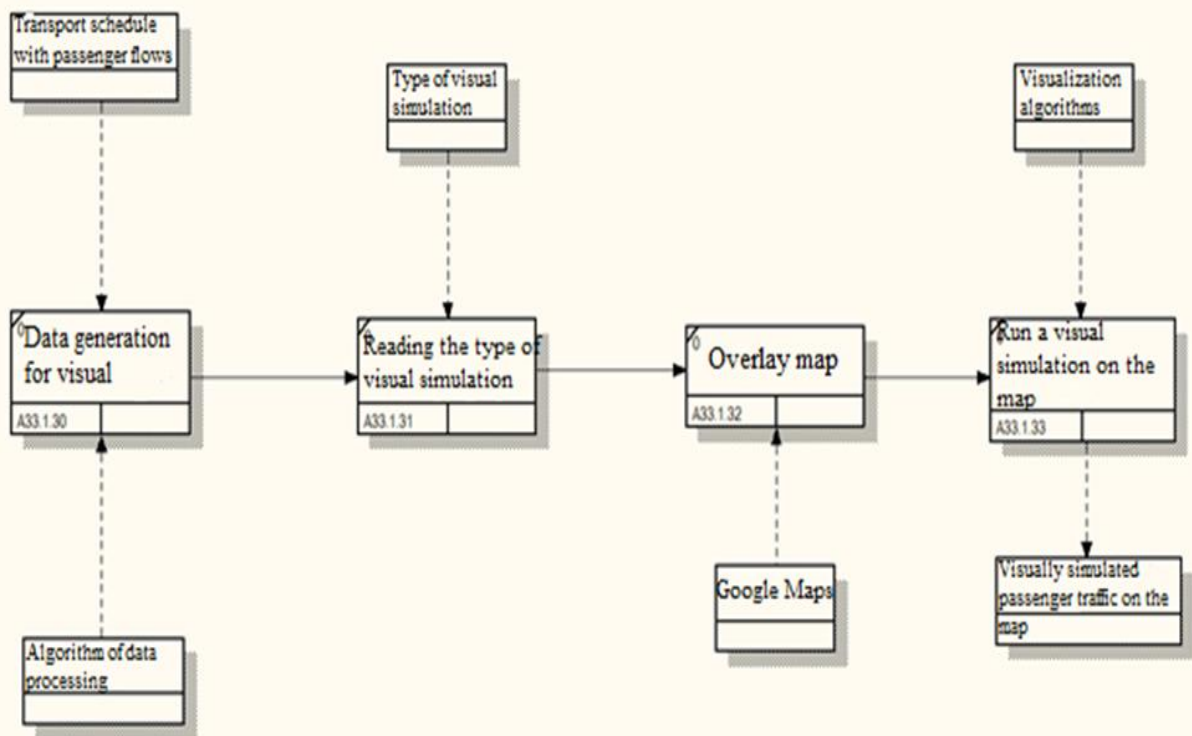

Figure 20: Decomposition of the block "Creating a schedule of transport stops"

This decomposition consists of three methods: "Determining the size of the neural network", "Creating a neural network model", and "Neural network learning process". The function Save block neural network starts with the process "Check the presence of a saved neural network", after which either the block "Delete the file of the previous neural network" will be executed, or there will be a transition to the union "Save neural network to file". The complete decomposition of this process is presented in Fig. 22.

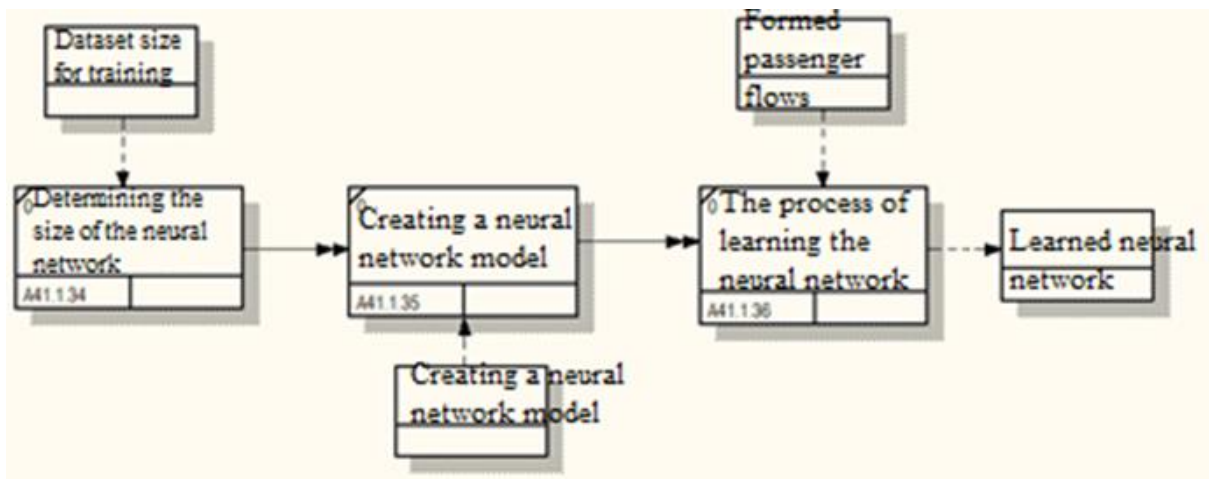

Figure 21: Decomposition of the Neural Network Learning block

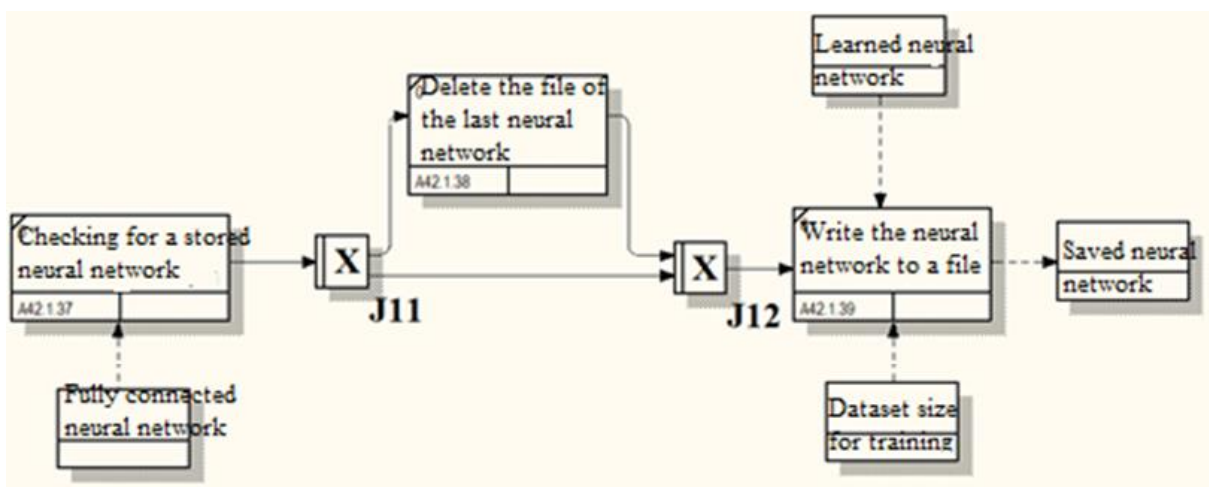

Figure 22: Decomposition of the block "Saving the neural network"

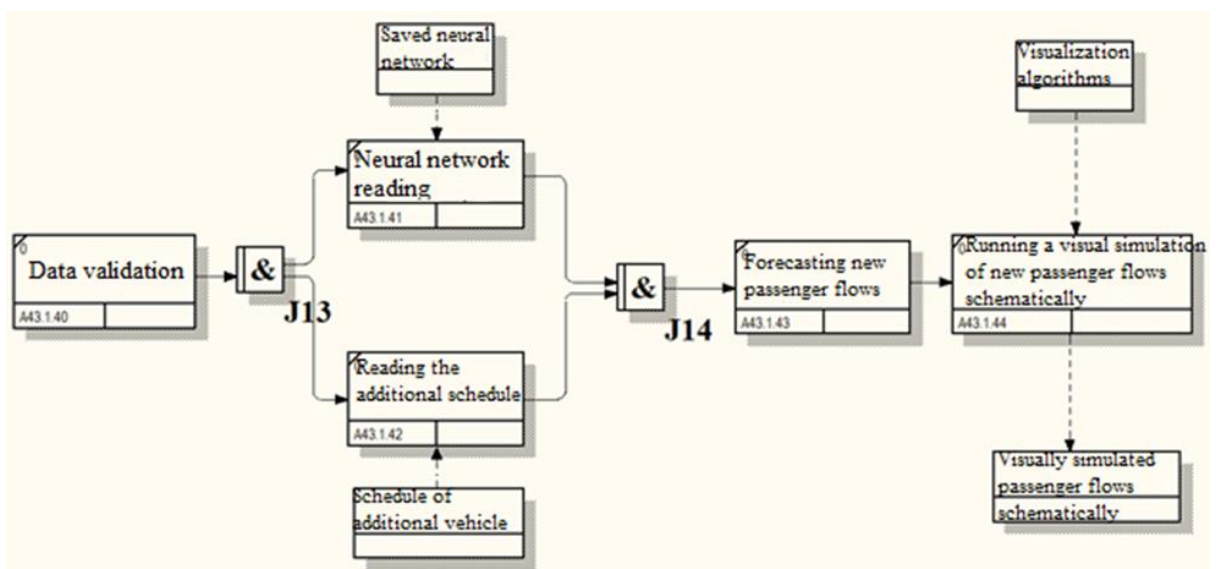

Figure 23: Decomposition of the block "Calculation of new passenger flows"

The last functional block that needed refinement and decomposition was "Calculation of new passenger flows". This process is successfully divided into several more detailed ones, the first of which is the process of "Data validation", followed by the parallelization of the following two processes "Read

neural network" and "Read additional schedule". As soon as these two processes are performed, the parallelism ends. There is a transition to the process of "Forecasting new passenger flows". Then there is a transition to the last block ", Start visual simulation of new passenger flows schematically", which completes this decomposition. An example of the above pollution is shown in Fig. 23.

3.3. Building a hierarchy of processes (functions, tasks)

Due to the use of specialized software for the structural design of information systems All Fusion Process Modeller, a prototype of such a structure is generated. The structure of the developed system is presented in the form of a hierarchy of tasks of different levels. Since one of the most common is a tree-like structure, its simplicity for analysis and implementation is used. This structure identifies hierarchical levels and groups of elements at the same distance, which, in turn, have the same number of edges to connect from the central part (tree root) to the current element. In general, hierarchical representation is prevalent and is also used for other purposes. The task tree is shown in Fig. 24.

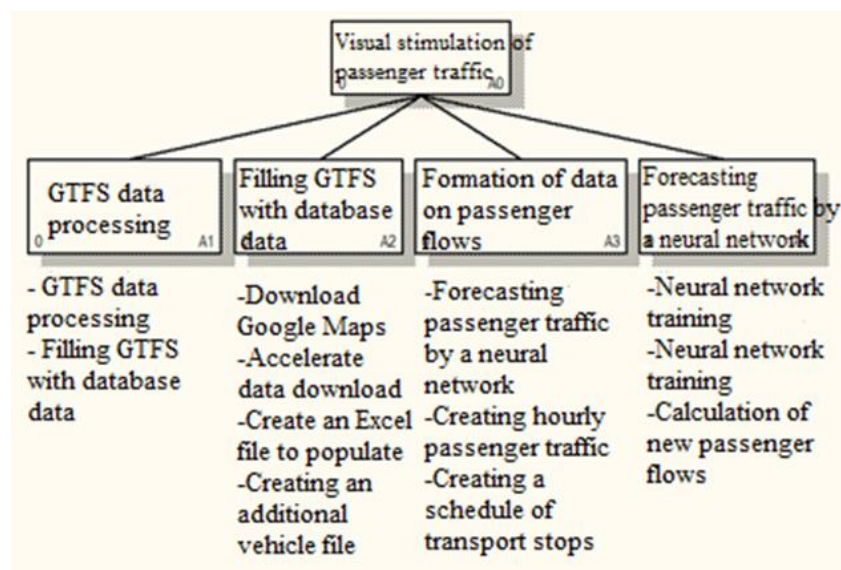

Figure 24: Task tree

Thus, thanks to the systematic analysis of the developed project, a tree of goals are built and described, which all aspects and criteria lists for achieving the overall plan. The type of the designed system, with the help of MAI, was determined from a set of alternatives. With specialized software, a hierarchy of tasks in the form of a tree is created.

4. Software for solving the problem

4.1. Selection and justification of means of solving the problem

The Python programming language is a high-level object-oriented language that allows you to use classes and their objects to build the structure of the software being developed. This language is interpreted, not compiled, which enables you to execute code "on the fly". The advantages of Python development include, first of all, pure syntax, which uses indents to separate blocks of code. Secondly, the portability of code allows you to use ready-made modules and add or correct them yourself. All this will always contribute to the successful use of this language in development; moreover, the ability to supplement modules is an essential point at the design stage of the system.

One of the essential technical characteristics is the presence of a standard distribution, which has many built-in functional modules for the developed product. Among those shown in Fig. 25 modules for data storage in the software product used: pickle, shelve and sqlite3.

- **Data Persistence**
 - `pickle` — Python object serialization
 - `copyreg` — Register `pickle` support functions
 - `shelve` — Python object persistence
 - `marshal` — Internal Python object serialization
 - `dbm` — Interfaces to Unix “databases”
 - `sqlite3` — DB-API 2.0 interface for SQLite databases

Figure 25: Built-in modules for data storage

However, one built-in module had to be abandoned and replaced with a more efficient one, namely this replacement for the Tkinter module. However, the existing built-in tools of the Python language provided all mathematical operations, calculations and data processing, as all these tools are best suited to the formulated tasks for this developed system. It is worth noting that from a technical point of view, the presence of a built-in module for working with SQLite influenced the choice of this language. The `sqlite3` module is included in the list of standard modules that come immediately with the Python distribution package, which is shown in Fig. 25. The TensorFlow module, an essential module for machine learning, greatly influenced the choice of this Python programming language. It is worth noting that if adequately installed software on the user's computer, you can use a graphics processor, rather than the usual processor for learning the neural network, which can, depending on the power of the graphics chip to speed up learning the neural network by 20 - 50%. This is confirmed by Fig. 26 extract from the documentation of the TensorFlow module.



Figure 26: Ability to use a video card for training

4.2. Technical characteristics of selected software development tools

The Python programming language version 3.7 is chosen as the basis for developing this software product, despite the current existence of a newer version (Python 3.8). This choice was also due to a specific additional factor, namely the support in the modules used in the current version of Python. These modules are necessary for the correct and correct solution of the task. Still, because third-party developers support these modules, the developer has not yet moved the modules to a new version due to technical problems with additional features provided in version 3.8. Fig. 27 shows a screenshot from the documentation of the TensorFlow module, which states that the maximum allowable version for correct operation is only Python 3.7.

Install TensorFlow 2

TensorFlow is tested and supported on the following 64-bit systems:

- Python 3.5–3.7
- macOS 10.12.6 (Sierra) or later (no GPU support)
- Ubuntu 16.04 or later
- Raspbian 9.0 or later
- Windows 7 or later

Figure 27: Support for TensorFlow versions of Python

Python is a common, high-level object-oriented language that is not compiled but interpreted, but at the same time, contains strict dynamic typing. One of the most important features is that Python supports both module packages and individual modules, which facilitates faster software development and the use of ready-made pieces of code created by other developers. It is also possible to do your modules for reusing code in different parts of the developed software product.

It is worth noting that the Python programming language is considered one of the most optimal and best languages for statistical analysis, research, and evaluation of various data sets, data processing and visualization. It allows solving the main task of the developed project: conducting a visual simulation of data on passenger traffic in public transport in Smart City.

Another important reason for rejecting other high-level programming languages was the high cost of time due to the writing of many templates and the required pieces of default code, which do not depend on the type of project. In turn, Python allows you to easily and quickly write the system's basic functionality without losing much productivity.

All the above features of this programming language and led to its choice compared to other languages valuable on the market, such as C # or Java. To fully understand the advantages and disadvantages of the Python programming language are summarized in Table 11.

Table 11
Advantages and disadvantages of Python

Advantages	Disadvantages
A large number of libraries (modules)	Speed limitations
Ability to expand	Weak in mobile applications and browsers
Increased productivity	Memory efficiency is not always efficient
Object-oriented	Limitations in architecture
Interpretability	More likely bugs

A specific module is used for each critical standard action, which is integrated into the developed product. These are the so-called aids used in the project to build the correct structure of the decision-making mechanism and the product's correct operation. Starting with the primary representation of the data encountered by the user, namely the main interface of the program, its development should be done using the PyQt module, which is currently available in version 5. In turn, this module is a shell for the well-known Qt library, only written in Python programming. PyQt's competitor is a built-in module called Tkinter. Tkinter is also a graphical interface library developed based on the Tk tool, which is widespread in GNU / Linux and other UNIX-like systems. Under Windows, there is only a ported version, which, of course, is not as high quality as the original. In general, the choice towards PyQt was evident from considering the functionality of the two modules. First, PyQt has a more extensive set of possibilities for building graphical interfaces. It has a more significant number of so-called layouts needed to make the window's structure with the correct placement of elements in it. The most crucial choice for PyQt was that it supports stream parallelization, is parallel data loading, or reformatting and updating the progress bar. This module supports its built-in way of downloading data over the Internet, which is essential in our case because the developed software product just updates GTFS data by downloading from the server. Not all the above functions are presented in the Tkinter module, so it was not selected to implement this software. The generalized comparison of the listed modules for creating the interface of a software product is presented in Table 12.

Table 12
Comparative characteristics of interface modules

Characteristics of modules	PyQt	Tkinter
Availability of widgets	Widgets are present	None
GUI for creating interfaces	Present (Qt Designer)	None
Type of interfaces	Modern	Outdated
Flexible programming	Available signals and slots	None
Built-in module	None	Yes

API Documentation Price	Available difficult Requires great skills Paid for commercial use	Available simple Easy to learn Free
-------------------------------	---	---

The input information received by the program is provided in GTFS format. The standard structure is shown in Fig. 28, where an additional example of filling in the list of routes is given. Special tools must use to interpret the data in this format correctly. The choice here was not great because there is only one module on the market that fully meets the needs. Other software codes and modules were freely available and could not provide the required functionality. However, they were so incompatible for use in the developed software product that the choice of this software module was evident and unambiguous.

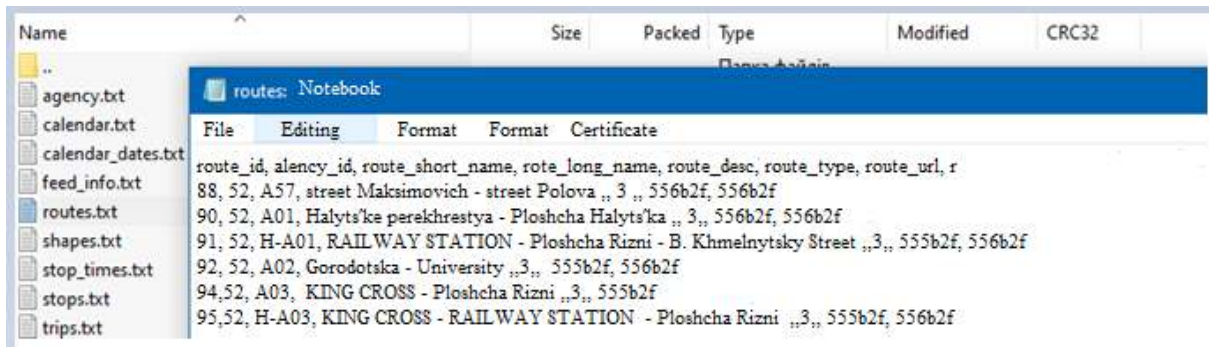

Figure 28: GTFS data format

Therefore, this software product works with transport data in GTFS format, so the pygtfs module is used to process this type. Although there was no choice, unfortunately, this module was not perfect. It did not entirely fit the program's needs, so part of this module is modified and supplemented with the necessary code for close and correct interaction of the developed software. The structure of this module is schematically shown in Fig. 29, which specifies the roles of each part and modifications that are necessary for the correct operation of the developed software product. Another way to present information for this software product is Excel spreadsheets, which are chosen because of their uniformity and everyday use worldwide. For the program to work, it is necessary to provide data on passenger traffic at each stop on a particular route during the day. There are several ways to collect this data: manually counting and recording by the appropriate people who will be at the stop or receiving this data from automated sensors located in the vehicle's doorways. In each case, the most obvious is presenting the results in the form of a table, which allows both to fill in this data manually and import it from third-party programs that control automated sensors in transport.

Two additional modules are used to work with Excel files: xlwt - for writing and xlrd - for reading. The recording module is necessary because the program creates a template for easy filling of passenger traffic data at stops in Excel spreadsheet format. After that, it reads the entered and filled in data for further processing and visual simulation. Fig. 30 shows the block diagram of the execution of the part of the software product, which uses the above modules to work with Excel files.

Now, regarding the ways of presenting the data used in work, the pygame module is used to implement the basic process of visual simulation, which is in the map mode and the schematic mode.

The module itself is designed to develop and create games and includes a large set of libraries for working with computer graphics. One of the most critical nuances was that pygame does not require OpenGL. It led to a choice between pygame and pyglet. Still, the choice was obvious because, as indicated in the specifications of these modules, pyglet is better used for 3D visualizations and pygame for 2D. Since this software product is designed for 2D visualization, the choice was made in favour of the pygame module. The complete list of advantages and disadvantages of these modules is given in Table. 13.

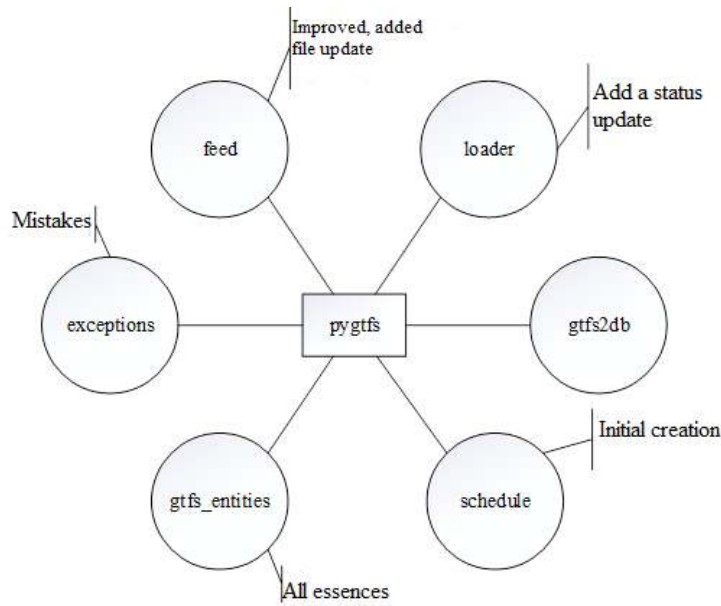

Figure 29: The structure of the pygtfs module with its modification

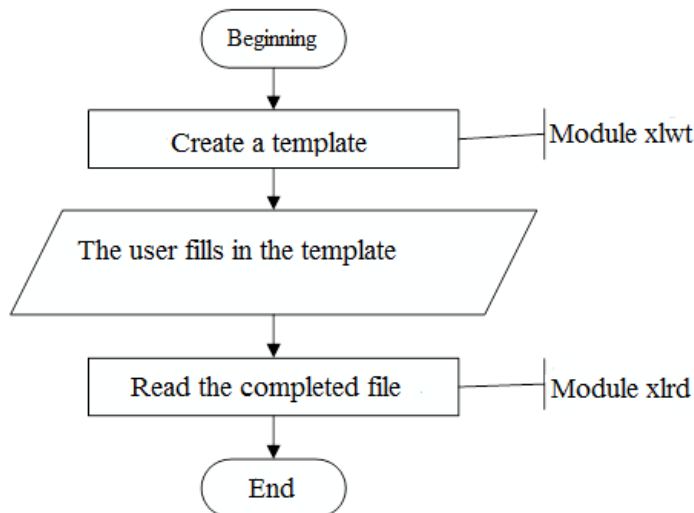

Figure 30: Block diagram for xlwt and xlrd modules

Table 13
Comparison of modules for graphical data visualization

pygame		Piglet
	Advantages	
Support 2D Simple syntax Ease of understanding Good layering system Based on SDL library Designed to create games Powerful set of tools		Support 3D Cross-platform Written in pure python Versatility
	Disadvantages	
Slow at high load Weak 3D support Does not support TMX cards		Small community and popularity Slow in 2D Not designed to create games

So pygame is developed more for 3D projects. It has OpenGL support. As you know, OpenGL creates more problems than it can solve. Suppose you look more at the development of this particular software (rather than general statements). In that case, OpenGL is not necessary at all and would only increase the needs of the hardware component of computers to run the program. All the basic graphical primitives used to create visualizations and simulations are present in sufficient numbers and without OpenGL. Therefore, based on all the development needs, the pygame module is chosen. Since the developed program predicts changes in passenger traffic when adding a new vehicle, a neural network is used for this prediction. The neural network is built and implemented using one of the best and most famous modules, which is TensorFlow. TensorFlow is an available machine learning software module developed by Google. Initially, this module was created to meet the company's needs in neural network development and then was released under an open license for general use. The block diagram shows the use of a neural network, which is created based on this module, as shown in Fig. 31.

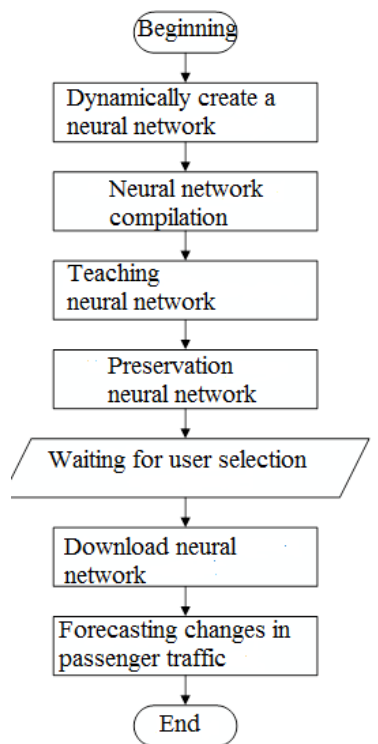

Figure 31: Block diagram of the neural network of the TensorFlow module

Compared to other modules, TensorFlow is the absolute leader because there is simply nothing better than this module. It is the de facto machine-learning standard for the Python programming language. Of course, due to significant functionality, there are disadvantages: the module, due to its large size, requires substantial hardware resources. The program uses its optimized part only to perform a specific task of forecasting changes in passenger traffic. Another downside is that this module does not allow you to use the latest version of the Python programming language because the latest stable version of the module is released only for Python 3.7. It is necessary to return to the arguments for choosing this language, turning the databases used description. Another critical factor that influenced the decision to select the Python programming language is a built-in module for using the SQLite database in this language. It is the most flexible in the setup and can easily be modified for specific problems in this software product (Table 14). It is also the most "light" compared to the already "heavy" TensorFlow module. Corresponding examples of databases application (Table 14) can be argued that SQLite is best suited to work. MySQL is also a hefty database that has too many features that are not needed in this software product, so the choice is made in favour of SQLite. For the correct operation of the developed software, two databases are used, each of which has its own clear purpose. They are separated due to the incompatibility of data to be stored there. One database is used to store GTFS data to easily query and get the information you need to run the program. The GTFS (General Transit Feed Specification) route data format itself is presented in the form of an archive in which text files are placed. Text files

have a clearly defined name according to the specification of this standard. This standard provides for the presence of mandatory and optional files, which are filled with additional information. The required set of files is shown in Fig. 32 and not required in Fig. 33.

Table 14

Example of using databases

SQLite	MySQL
Development of small standalone applications	Web applications
Projects that do not require large scalability	Multi-user access to the program
There is a need to read and write directly from the disk	For distributed systems
Simple development and testing	The need for large databases
The need for portability of the program	The need for strong security and authentication

- Required files
 - agency.txt (Agency)
 - stops.txt (Stop)
 - route.txt (Route)
 - trips.txt (Trip)
 - stop_times.txt (StopTime)
 - calendar.txt (Service)

Figure 32: Mandatory file set for GTFS standard

- Optional Files
 - calendar_dates.txt (ServiceDate)
 - fare_attributes.txt (Fare)
 - fare_rules.txt (FareRule)
 - shapes.txt (ShapePoint)
 - frequencies.txt (Frequency)
 - transfers.txt (Transfer)
 - feed_info.txt (FeedInfo)

Figure 33: Additional file set for GTFS standard

This software mainly works with the required set of files. It is since for the visual simulation of passenger traffic, the rest of the data is indirect. Each text file according to the specification contains its template, according to which it must be filled. Only correctly filled files are allowed to work in the program, Google on their site designated for this standard checks the correctness before the publication of these files. Because the data is presented simply in text files and separated by commas and are CSV (comma-separated values) files, this feed format is neither convenient nor optimized for use and processing in the program. Therefore, the above and described pygtfs module is used to solve this problem, which uses the SQLAlchemy module to convert text documents into a relational database. An example of a CSV file is shown in Fig. 34.

```
stops: Notebook
File Editing Format Appearance Certificate
Stop_id, stop_code, stop_name, stop_desc, stop_lat, stop_lon
4563, 0593, Halyts'ke perekhrestya (0593), B. Khmelnytsky Street
4564, 0575, Chyhyrynska (0575), B. Hrinchenko Street 2A, 49. 876
```

Figure 34: CSV file

Default by the pygtfs module uses the SQLAlchemy module, so there is no need to replace it. SQLAlchemy is released in 2006, has since become the best, and most widely used among Python developers for object-relational database representation (ORM). This module provides the ability for ORM to display a database for Python. The structure of this module is shown in Fig. 35.

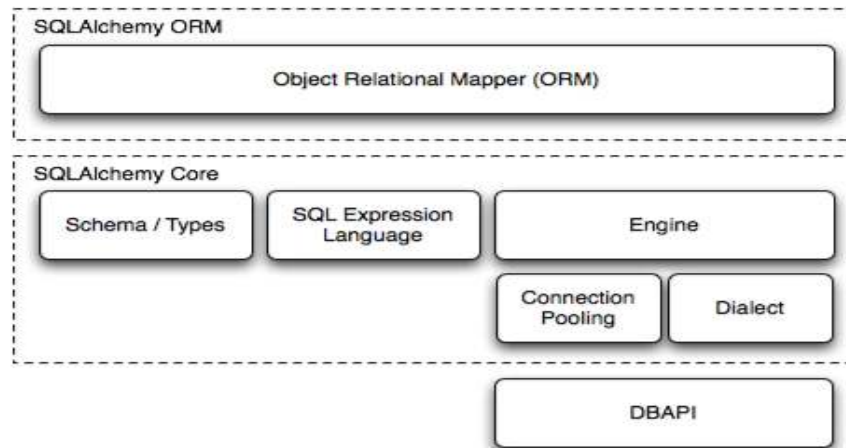

Figure 35: The structure of the SQLAlchemy module

Therefore, summarizing the above, the first of the two databases is a relational database used to store data in GTFS format, the structure of the tables shown in Fig. 36. This database is managed by the relational SQLite database management system and is created using an object-relational representation using the SQLAlchemy module. This database does not come with this software but is self-generated when you first run the program and download GTFS data from the server. For example, Fig. 37 shows the structure of one of the database tables for the GTFS standard.

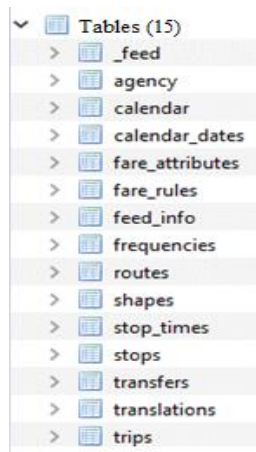

Figure 36: GTFS format database structure

Column Name	Data Type
feed_id	INTEGER
route_id	VARCHAR
agency_id	VARCHAR
route_short_name	VARCHAR
route_long_name	VARCHAR
route_desc	VARCHAR
route_type	INTEGER
route_url	VARCHAR
route_color	VARCHAR
route_text_color	VARCHAR

Figure 37: Route table structure

The second database is already supplied with the software product and is used to store user data.

Because the program being developed does not use registration, authorization, and session concepts, the program has a current user by default who uses the program and saves its settings, which can also be deleted (such as the Google Maps API key). This database is also managed relational database management system SQLite. In this case, because this database is not so cumbersome (due to a large amount of data), it has interacted with the usual SQL queries. The view of this database is shown in Fig. 38.

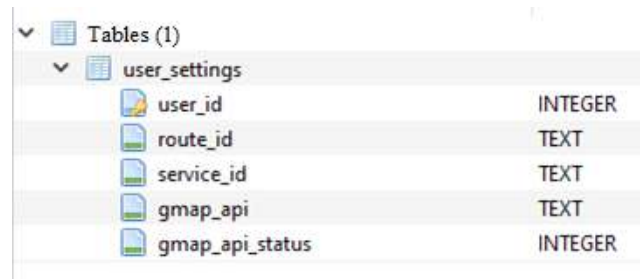

Tables (1)	
user_settings	
user_id	INTEGER
route_id	TEXT
service_id	TEXT
gmap_api	TEXT
gmap_api_status	INTEGER

Figure 38: Database view for storing user data

The PyCharm software system is chosen as the development environment. This software product is considered fundamental for developing programs in the Python programming language. The choice is made between this development environment and VSCode. However, due to the possibility of creating a virtual environment with a separate installation of modules in it, without interfering with the operating system and an extensive range of tools for debugging software products, the choice is made in favour of PyCharm. However, VSCode does not provide a good set of features for high quality and fast debugging of software products, consisting of many modules and components and a large number of files. PyCharm has all the appropriate tools to handle such large projects. An example of a development window in the PyCharm environment is shown in Fig. 39. The development is based on the Windows operating system, so this aspect did not affect the choice of software for development.

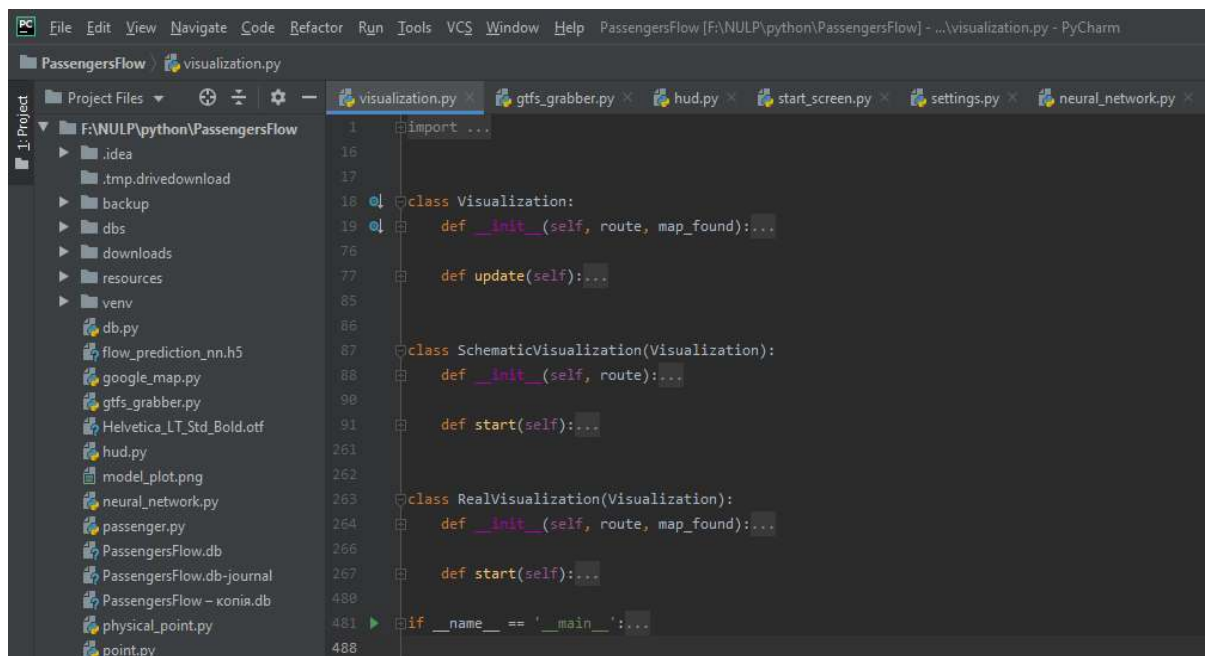

Figure 39: PyCharm window

The study, as a result, the choice in favour of the Python programming language and the use of its appropriate modules to solve the problem was successfully substantiated. Examples of various software development tools that can use and the best options for this topic are selected from them.

5. Practical implementation

The description of the created software, given below, is issued according to the GOST 19.402-78 standard "Description of the program".

5.1. Description of the created software

5.1.1. General information

The full name of the program: "Visual simulation of passenger traffic", is shown in Fig. 40. Abbreviated name and designation of the program: "VSP".

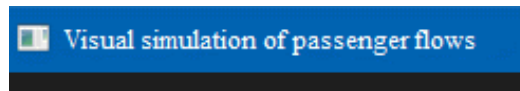

Figure 40: Name of the software product

For the software to work correctly, you must have the following software installed: the Windows operating system, the Python interpreter, and the required set of modules. The developed software is written in the Python programming language. SQL queries are used to communicate with the database.

5.1.2. Functional purpose

First, this software product, designed for visual simulation of passenger traffic in the field of public transport in Smart City, has two display modes: schematic and "on the map". An example of a visual simulation in the "map" mode is shown in Fig. 41.

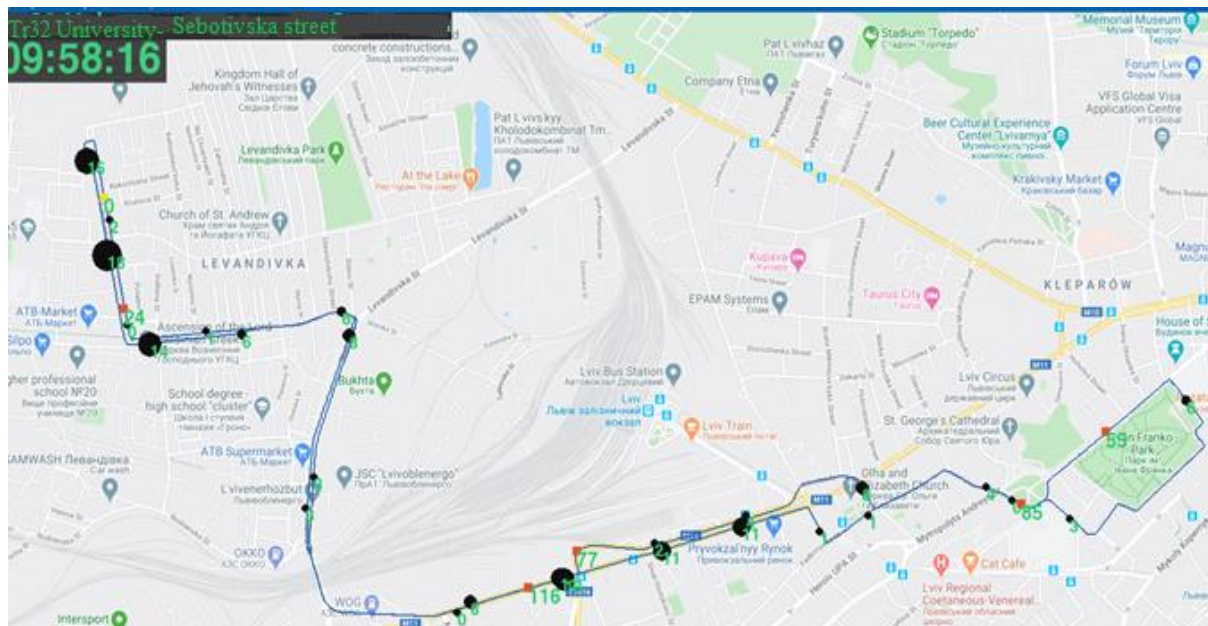

Figure 41: Visual simulation in the "on the map" mode

The software provides the ability to predict changes in passenger traffic. It is done using a specially designed neural network. To obtain a forecast using the neural network, you need to provide a schedule of the new vehicle that is planned to add to the current route. The change in passenger traffic will occur during the race and may depend on the time of day and the load of the current path. The predicted changes are visualized in the schematic mode of visual simulation, as shown in Fig. 42. Functional limitations include the ability to change only one route at a time.

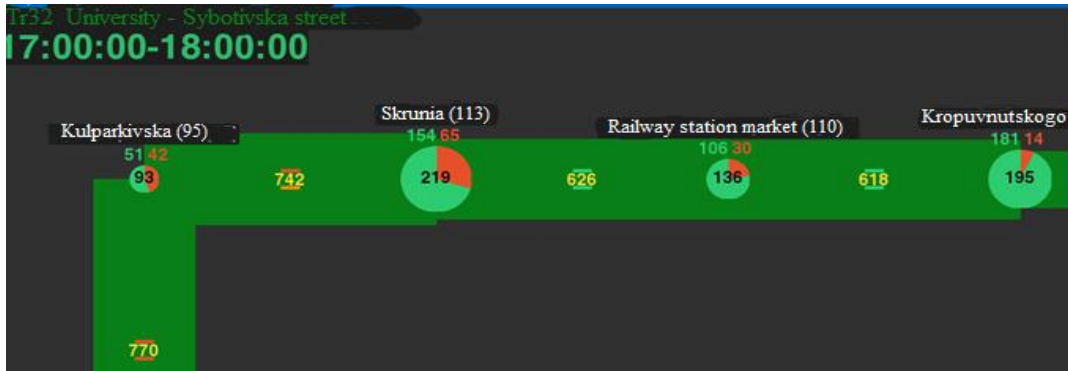

Figure 42: Visual simulation after forecasting

5.1.3. Functional purpose

This software product uses several algorithms, some of which are well known and others are unique and developed independently to solve specific problems necessary for this work. To process GTFS data, a unique algorithm of own development is used, given in the form of a block diagram in Fig. 43. This algorithm is designed to convert the provided data on stops and main points on the route in GTFS format into the correct image on an actual map with the division of the way into two parts: forward and reverse. Well-known algorithms include an algorithm for reading and parsing CSV files and an algorithm for drawing graphic primitives.

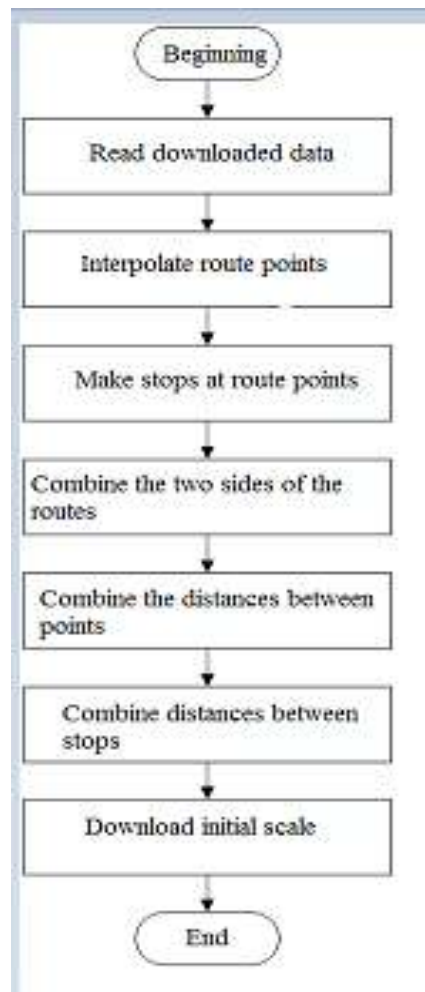

Figure 43: Block diagram of the GTFS data processing algorithm

Below is the part of the code that corresponds to the block diagram shown in Fig. 43:

```

self.get_data()
self.make_more_points()
self.make_stops_on_points()
self.correct_first_stop()
self.combine_sides()
self.calculate_distance_between_points()
self.calculate_distance_between_stops()
self.load_zoom(s.ZOOM)
self.create_grid()

```

A unique visual simulation algorithm has specially developed to solve the set tasks, which provides an opportunity for visually displaying traffic and existing passenger flows both on an actual map and schematically. The algorithm for creating a schematic mode of visual simulation is given in a block diagram in Fig. 44.

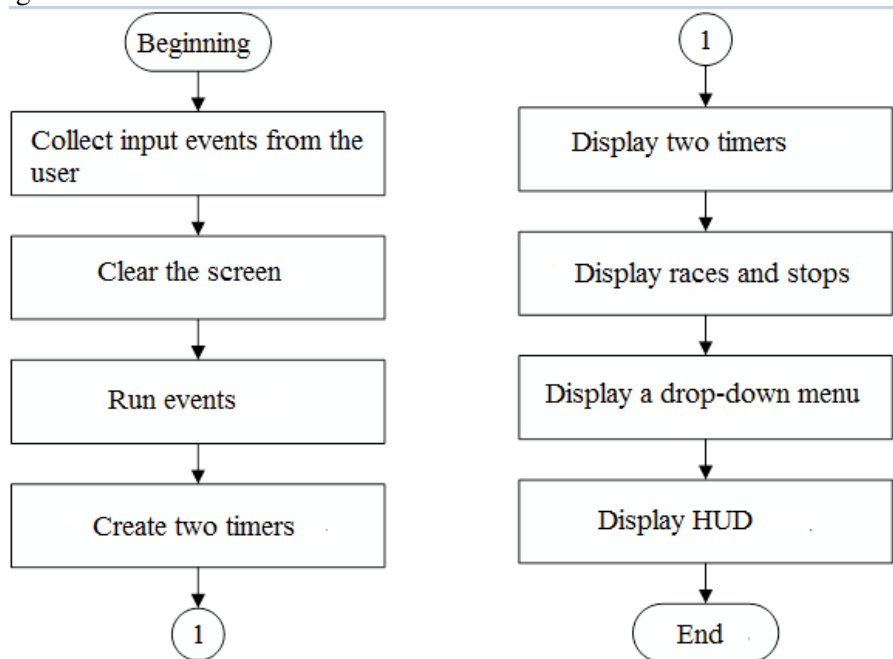

Figure 44: Block diagram of the algorithm for creating a schematic mode

In general, the visual simulation algorithm consists of three classes: the parent class Visualization and two classes SchematicVisualization and RealVisualization, which inherit the parent class. This inheritance is clearly presented in the form of a diagram in Fig. 45.

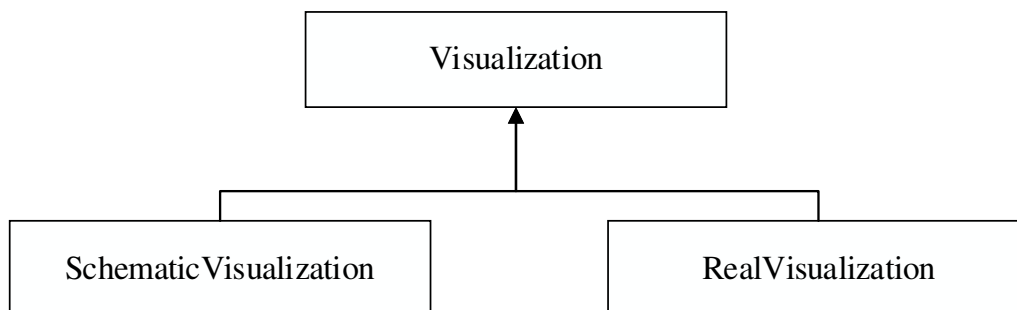

Figure 45: Schematic representation of inheritance

The developed software product uses various methods that perform the functions necessary to ensure its correct operation. Some of the methods and tools are systematized in Table 15.

Table 15

Methods and tools used

The name of the method or tool	Place of use
Interpolation	Create additional points to display the route
The shortest distance from a point to a straight line	Projection of a stop on a route
The smallest distance between two points	The total length of the route and the distance between stops
World geodetic system WGS 84	Transmission of GPS coordinates
Mercator projection	Convert GPS coordinates to world coordinates
Pixel coordinates on Google Maps	Convert world coordinates to pixel coordinates
Neural network	Forecasting changes in passenger traffic on the route
Karney Method (2013)	The distance between two points given by GPS coordinates

The function of predicting changes in passenger flows uses the capabilities of a neural network with fully connected layers, which is based on an optimization algorithm with an adaptive level of learning Adam. The size of the neural network is determined dynamically and depends on the size of the dataset on which the training will take place. An example of the code by which this neural network is generated is as follows:

```
self.model.add(keras.layers.Dense(round(len(self.data) / 2), input_dim=5, activation='relu'))
self.model.add(keras.layers.Dense(round(len(self.data) / 4), activation='relu'))
self.model.add(keras.layers.Dense(1))
```

A possible view of the neural network is shown in Fig. 46.

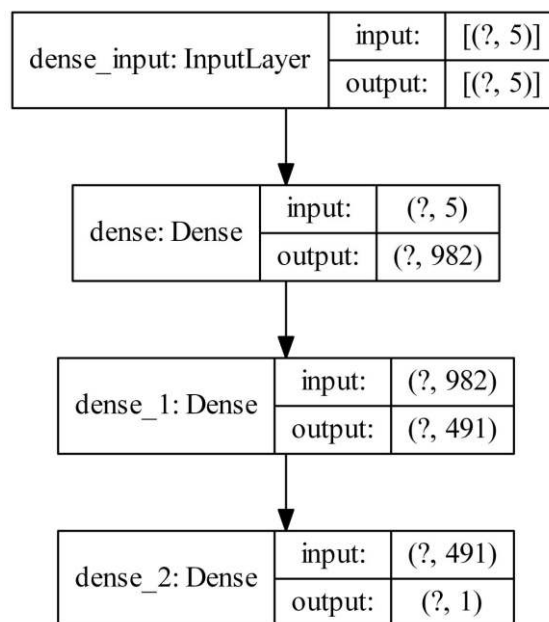

Figure 46: An example of the structure of a neural network

This software also has a database that is responsible for storing data in GTFS format. To properly store this data, it is necessary to have a strictly defined database structure with foreign keys. Fig. 47 shows a database diagram showing the main tables that correspond to the key types of the GTFS standard. Therefore, such tables are stop_times, containing the foreign key trip_id from the table trips and stop_id from the table stops. In turn, the stops table has only a stop_id key. The trips table contains three foreign keys: service_id from the calendar table, shape_id from the shapes table, and route_id from the routes table. The trip_id field is its unique key. The calendar_dates table also contains the

service_id foreign key from the calendar table. Finally, the routes table contains the agency_id key from the agency table. The calendar shapes and agency tables do not have foreign passports. All of the above tables also include one common foreign key feed_id from the table _feed, which is not shown in Fig. 47 since it is a system table and it has nothing to do with understanding the structure of GTFS data.

5.1.4. Technical means used

When using the program, you must have a personal computer or laptop that is based on an Intel Core i5-6500 processor or equivalent from other manufacturers. With lower technical characteristics, the software was not tested. However, from the software point of view, it is possible to reduce the frame rate in the mode of visual simulation on weaker processors and increase the time for neural network training. All other functions will work correctly. Table 16 shows the maximum number of frames during a long-term run of a visual simulation. As can be seen from Table 16, the performance of the software is kept almost at the same level during a long visual simulation session in the "on the map" mode, which substantiates the claim that the software is optimized and there are no problems with loss of performance or memory clutter.

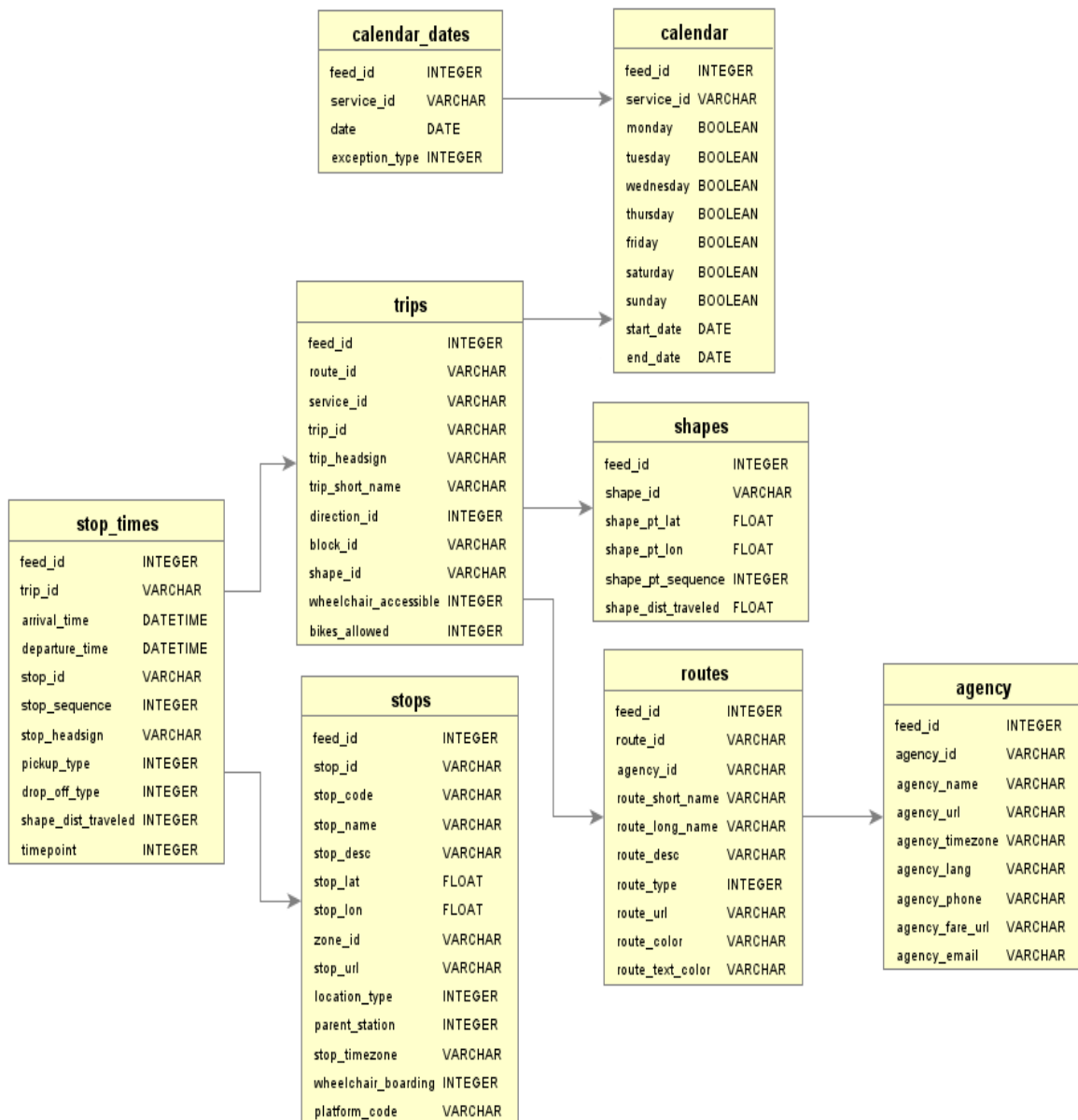

Figure 47: Database schema for GTFS data

Table 16

Productivity of a software product

Time to run	Maximum number of frames
0 min	318
5 min	306
10 min	312
15 min	301
20 min	305
25 min	304
30 min	309

5.1.5. Calling and Booting

The program can be started by opening an executable file or a shortcut to this executable file. When downloading the program, the user will always get to the main menu, regardless of where the last session ended.

5.1.6. Input data

Input data for the software product is presented in several ways. First, data on transport routes from the relevant servers of the city are downloaded, and in the international standard GTFS are submitted. Data on passenger flows are presented in a unique template, which is defined in Excel format. An example of a template is shown in Fig. 48.

Bus stop	Arrival time	Departure time	Entered	Got off	Design capacity of the vehicle	Maximum vehicle capacity
University (78)	07:17:50	07:18:10	39	0	105	116
Cathedral of St. George (771)	07:20:50	07:21:10	3	0		
Kropyvnytsky (46)	07:23:50	07:24:10	11	4		
Railway station market (110)	07:25:50	07:26:10	10	8		
Skrynya (113)	07:27:50	07:28:10	15	11		
Kulparkivska (95)	07:29:50	07:30:10	9	9		
Narodna (96)	07:30:50	07:31:10	8	14		

Figure 48: Excel file to fill with passenger exchange

Data on the new vehicle are also provided in the GTFS standard but do not require a complete set of files, i.e., using its own light version of this standard, shown in Fig. 49.

```

File  Editing  Format  Appearance  Certificate
trip_id,arrival_time,departure_time,stop_id,stop_sequence,shape_dist_traveled,timepoint
12420_0_1,16:25:00,16:25:00,4795,2,,1
12420_0_1,16:26:00,16:26:00,4796,3,,1
12420_0_1,16:27:00,16:27:00,4797,4,,1

```

Figure 49: File with additional transport

Route data is transmitted in zip archive format, which contains txt text documents. Data on passenger traffic is presented in a file with the extension xls. Data for the new transport unit, although supporting the GTFS standard, does not require archiving and uses only the txt text file.

5.1.7. Initial data

The software product generates the original data in two formats. The first is an Excel file, which created a template for filling passenger traffic at stops, shown in Fig. 48. Another is a visual

representation, which is presented in the form of a visual simulation in the "map" mode (Fig. 41) or schematically (Fig. 42).

5.2. User manual

5.2.1. Introduction

Purpose of the document. The software product works as a separate desktop program with a standard interface for the primary user interaction, as shown in Fig. 50. When you run a visual simulation, the program creates a new interactive interface for user interaction, which differs in the modes "on the map" and schematic. The differences in the interfaces are shown in Fig. 51, Fig. 52.

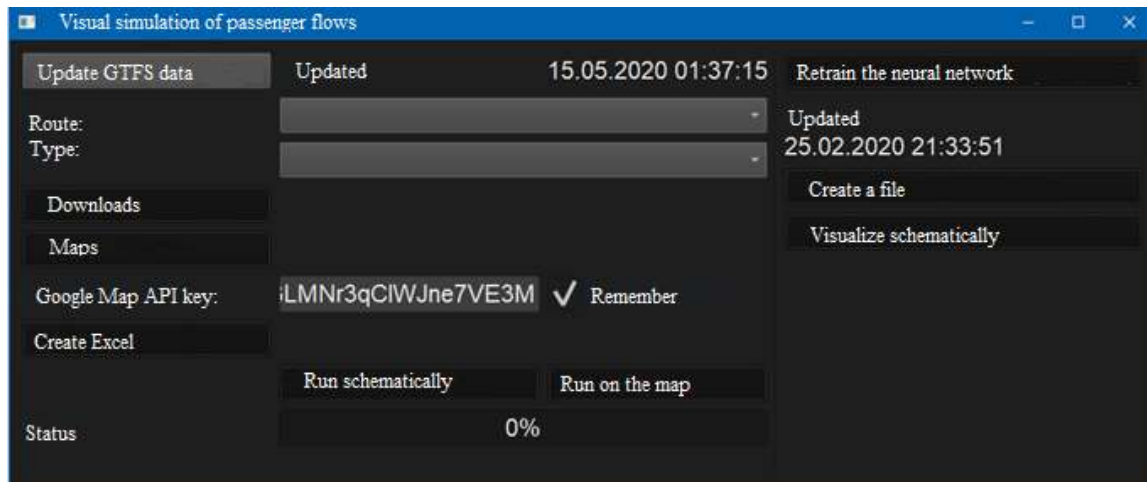

Figure 50: The main interface

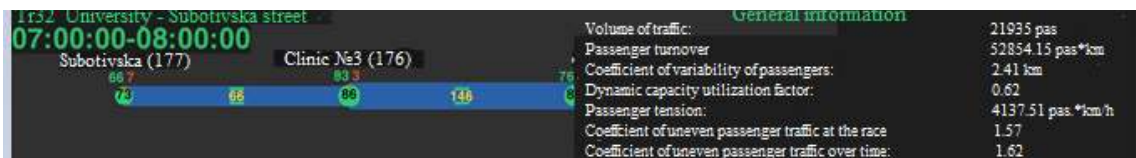

Figure 51: Unique drop-down menu in schematic mode



Figure 52: Unique part of HUD in "on the map" mode

The software product's functionality is a visual simulation of passenger traffic on routes presented in the GTFS standard. The functionality includes:

1. Use of the international standard of the description of the schedule of movement of public transport GTFS.
2. The visual simulation of passenger traffic in the "on the map" mode.
3. Visual simulation of passenger flows in schematic mode.
4. The forecasting changes in passenger flow when adding a new transport unit to the route.
5. Display of new passenger flows in the schematic mode.

Thus, the program is designed for accessible and visual presentation of passenger flows on routes and passenger exchanges at public transport stops. The software product provides the ability to display both current and projected passenger flows. The primary condition for use is managers and relevant civil servants' need to improve public transport services in Smart City. Due to the lack of top management of the transport company to make changes to the current structure of the city's route network. To fully use this software product, you need to have all the input data, namely: data on routes provided in the international GTFS standard and data on the number of passengers who used specific ways during the day. Collection of information on passenger exchange at stops can be carried out both by automated sensors (Fig. 53) inside vehicles and by the usual counting of passengers at stops of the corresponding route. All basic settings of the software product are made before its release, and the software does not require additional intervention. The only option you can change is the Google Maps API key. The key itself is optional but can be entered when the user wants to display an actual city map against the background of the "on the map" mode. This key can be saved for further launches of the program. However, it is allowed to enter each time anew. It is admissible at the exhaustion of the acceptable quantity of its uses (Fig. 54).



Figure 53: The scheme of operation of the automated sensor of counting of passengers



Figure 54: Google Maps key API input field

5.2.2. Third level heading

Designation and name of the program. Full name: "Visual simulation of passenger traffic", which is shown in Fig. 40. Abbreviated name: "VSP". Programming languages in which the program is written. The software product is written using the python programming language and the PyCharm development environment. This program is designed for use in public transport to improve the quality of passenger transport services. Program features. This software product allows you to update GTFS route data from official city servers. The update status is indicated in the first line of the main menu (Fig. 55). It also allows you to choose a specific route and its type (weekday or weekend) in which it operates. To display passenger flows during the working day, select "Weekday" from the drop-down menu (Fig. 56). The software allows you to enter data on passenger traffic at a stop in the format of Excel spreadsheets. To form a template, you must press the "Create Excel" key, which is shown in Fig. 57.



Figure 55: Data update status

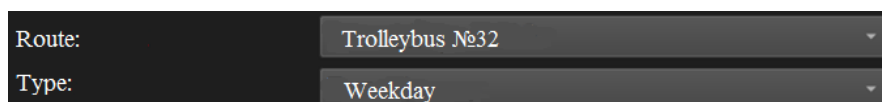

Figure 56: Route selection and its type



Figure 57: Key to create an Excel template

To run a visual simulation in the program, you must select one of two modes of information presentation: "on the map" or in a schematic version. The corresponding buttons are shown in Fig. 58.



Figure 58: Selection of visual simulation mode

The user is also given the opportunity to learn the neural network based on the entered data and create a forecast of changes in passenger traffic due to the addition of a new vehicle. The corresponding toolbar for performing all the above functions is shown in Fig. 59.

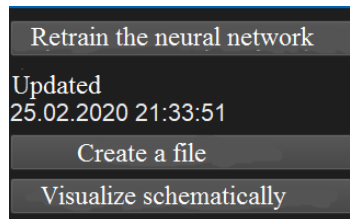

Figure 59: Neural network toolbar

5.2.3. Classes of solved tasks

The tasks to solved are:

- Conduct a visual simulation of passenger traffic in schematic mode;
- Conduct a visual simulation of passenger traffic "on the map";
- Predict a change in passenger traffic due to the addition of another vehicle.

Methods of solving problems. This software product uses both proprietary and well-known algorithms to solve all tasks. The methods developed include those that create a visual simulation in two modes and calculate the dynamic coefficients of filling and congestion of transport units. Commonly known algorithms include the calculation of parameters for passenger traffic and passenger traffic. The interpolation method is used to create additional points on the route for smoother movement of vehicles. To design the location of a stop on a way is the method of the smallest distance from a point to a straight line. In addition, to find the length of the way and the distance between stops, the smallest distance between two points on the plane. The use of these methods is illustrated in Fig. 60.

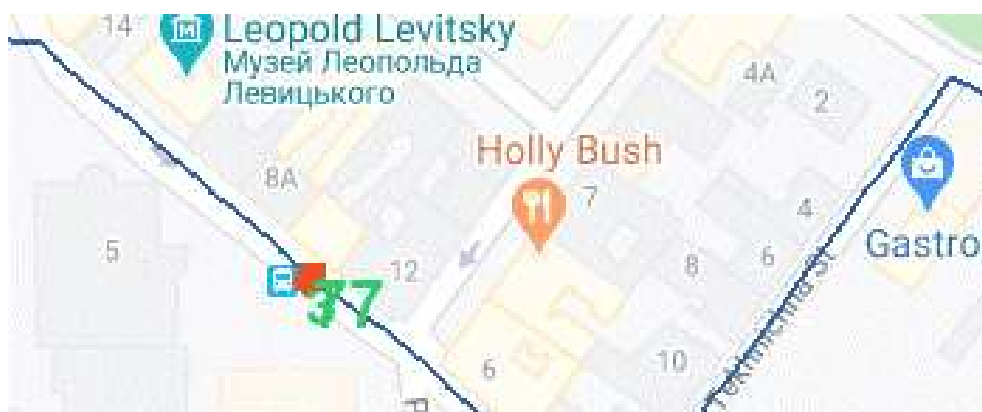

Figure 60: Vehicle that stopped at a stop

Using a neural network, which is generated dynamically according to the input data to predict changes in passenger traffic, is based on the principle of a particular constant number of hidden layers and the dynamic number of neurons in each layer.

Functions performed by the program. This program can perform the following functions:

- Perform analytical analysis of GTFS data and passenger traffic data;

- Visually simulate passenger traffic in two different modes for the available presentation of the provided data;
- Dynamically generate the number of neurons in the layers of the neural network based on the input data;
- Anticipate changes in passenger flows when adding a new vehicle to the route.

5.2.4. Description of the main characteristics and features of the program

Time characteristics. Using this software product significantly reduces the time spent on direct research and visualization of manually collected data on passenger traffic and passenger exchange on public transport routes. The program also provides additional features that cannot be done manually.

Operating mode. The system works on demand. That is, when you need it, then you can run it. The program does not need to work around the clock's control of correctness of execution and self-recovery of the program. The program interface is built on the principle of CE (Chain Elements), according to which the interface does not allow the user to press the buttons responsible for processing data that does not yet exist or for currently unavailable capabilities. It is impossible to violate a specific sequence of actions at the development stage through the locked buttons (black) shown in Fig. 61, with possible interaction only with grey elements.

For control in the software product, there are information windows and inscriptions in the main interface, which will help understand the reasons for failing to perform a specific action.

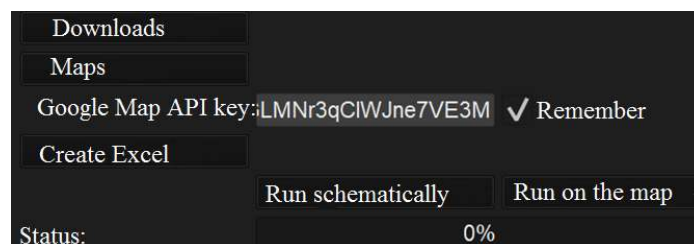

Figure 61: Locked main menu items

Limitations of the scope of the program. The main rules in the use of this software are:

- Impossibility of application to non-scheduled passenger traffic;
- Impossibility of application for freight transportation;
- Impossibility of application for other types of passenger transportations.
- Lack of route data or routes in GTFS format;
- Lack of data on the number of passengers entering and leaving the transport at stops, i.e. passenger exchange.

5.2.5. Information on functional limitations for use

Conditions required for the program. The main requirements are:

- To have access to data on passenger flows;
- To be able to change existing schemes of the city's route network.

You must have a Windows-based desktop or laptop to run the system. You must also install Python and its modules. Requirements for the composition and parameters of peripherals. To use the program, you need a connected monitor, keyboard and computer mouse. For the program to work, you need to have Python and its corresponding modules installed. The software product is presented in a file that will independently install the appropriate necessary application software.

To use the product, the Windows 10 operating system must be installed. There are no special software requirements. You need an Internet connection to download GTFS data and download maps, but the data is cached and does not require an Internet connection after the upgrade.

5.3. Analysis of the control example

When you start the program, the main screen of the software product is the interface shown in Fig.62, a feature of which is the inability to work with elements that respond to blocked functions. The user has access only to those buttons, the functionality of which is not limited now. Only after using the action buttons, the user will gradually have access to the following interface elements. The user can be sure at any time that if the button is active, the action it describes will perform.

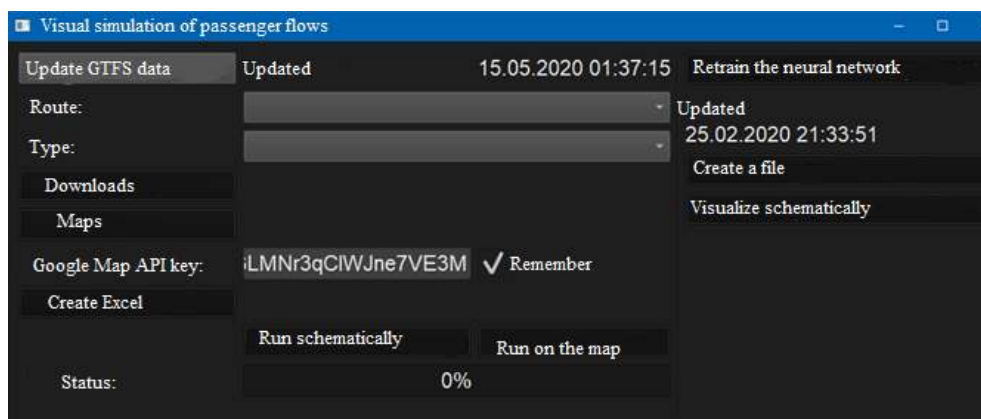

Figure 62: Main interface

The first steps available to the user are only the ability to update GTFS data and select the route and its type (Fig. 62). The program interface is immediately made in the dark mode, which is very popular today for all software products and sites. In addition, it is more pleasing to the human eye and is not too bright. In the absence of data, only the download of new data will be available, as shown in Fig. 63. After selecting the route and its type, all other buttons and fields are activated, and it is indicated which type of download will be performed: "fast" or "slow". "Fast" occurs when the program has cached data, and "slow" - if you need to create a new cache for subsequent launches. Immediately after that, information about the availability of downloaded maps is displayed. The program does not require maps if the user does not have an API key for Google Maps or does not want to use maps. The map mode will be displayed without a map in the background but with all proportions and scales.

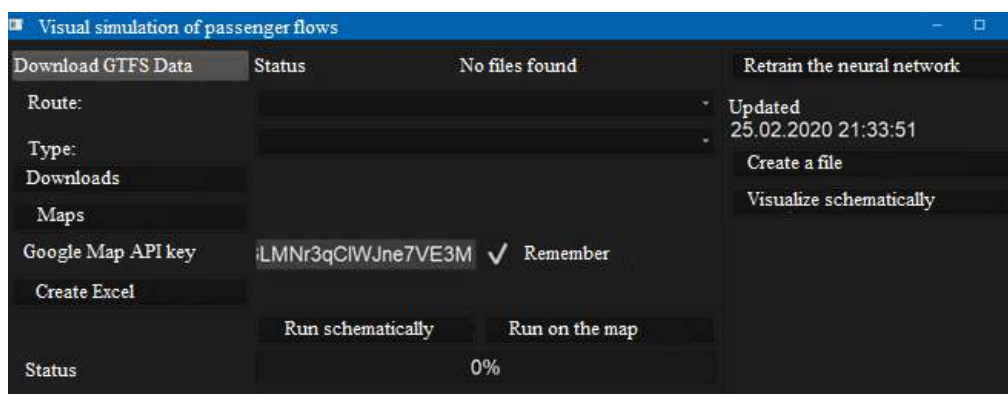

Figure 63: Main interface without data

The main program window, which shows all the new available features, is presented in Fig. 64.

The "Create Excel" button generates a file to fill it with passenger traffic for each transport route. The Excel file is selected based on several factors, namely:

- Data on passenger traffic can be collected simply by people who stand at stops and count it manually, and then be transferred to an Excel spreadsheet;
- Special sensors with the help that are installed on the doors of vehicles, which in turn will be able to export the collected data to an Excel spreadsheet.

After successfully filling the Excel file with data on the number of passengers at stops, you can choose any mode of operation, whether schematic or "on the map". According to their location on the forward and schematically reverse directions, the endings are marked one after the other. It supports scrolling up and down with the mouse to view all stops, navigating with the arrows to select the next or previous time intervals with an interval of one hour. The interface of this model uses different colours to indicate various indicators, states and phenomena. It is due to the need to make the program interface as intuitive as possible (without reading the documentation) shown in Fig. 65.

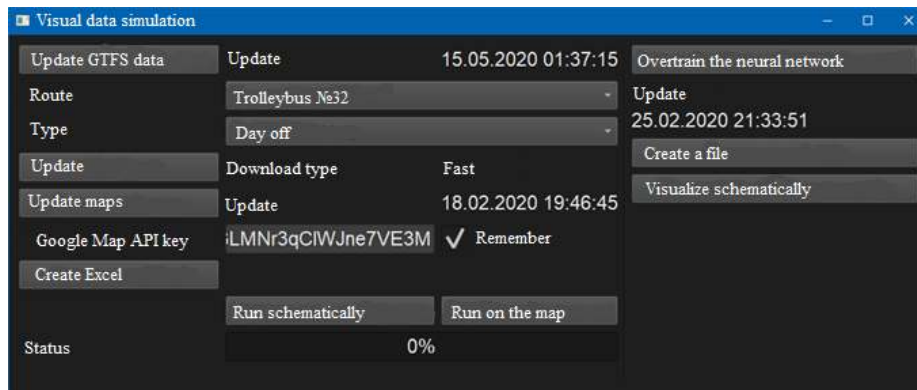

Figure 64: The main interface is fully active

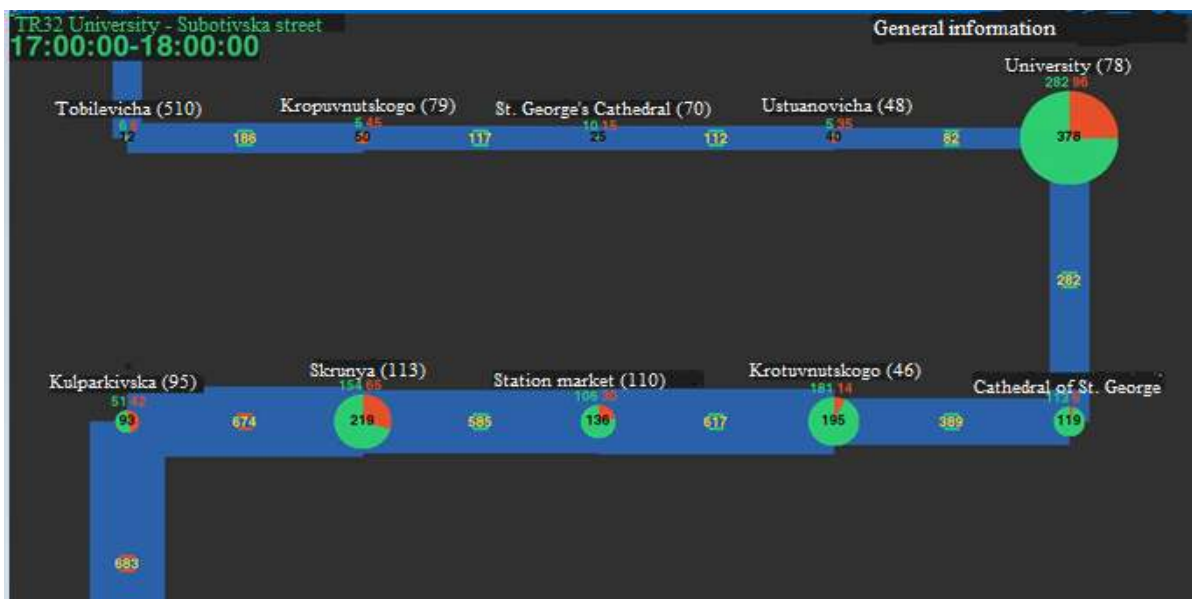

Figure 65: Schematic mode

When you use the D key, you can view general information for the whole day, not hourly. Each stop is signed with the name and number used at the actual stops in the city on the appropriate road signs (Fig. 66). These data show the number of passengers who came in and out at the stop for a specific period, and even lower - the sum of all passenger traffic at the stop (Fig. 66).

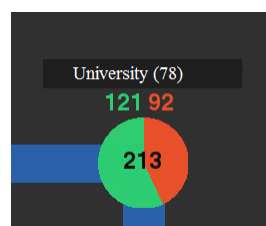

Figure 66: Display stop in schematic mode

The size and segments of the circle are determined dynamically. The larger the radius of the circle - the more people at this stop came and went (relative to the maximum number in each hourly interval during the day). The sectors are marked in different colours to display the ratio of those who came in and those who came out at the stop. Between stops, a comprehensive line, the size of which changes dynamically, indicates passenger traffic. The number on it (Fig. 67) shows how many people are transported during this hour on this race between stops.

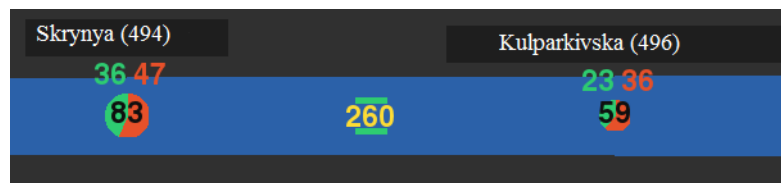

Figure 67: Display of the race between stops

The colour of the top underline the load factor of the vehicle relative to its design capacity and can be displayed in three colours (Fig. 67):

- Green (norm): less than 0.9;
- Orange (permissible excess): 0.95 - 0.99;
- Red (critical excess) 1.00 and more.

The colour of the underscore, in turn, depends on the load factor of the vehicle relative to its actual capacity and can be displayed in three colours (Fig. 67):

- Green (norm): the coefficient of structural capacity is less than 1.00;
- Orange (permissible excess): the coefficient of structural power is more significant than 1.00, but the coefficient of actual capacity is less than 0.95;
- Red (critical lot): in other cases.

In this mode, you can also click on the stop and get more detailed information about it, an example, a window shown in Fig. 68. Races between stops also support the function of an additional data window, which shows the maximum bandwidth of the race on several parameters, where all overloads are visualized by a change of colour, as illustrated in Fig. 69.



Figure 68: Stop data window

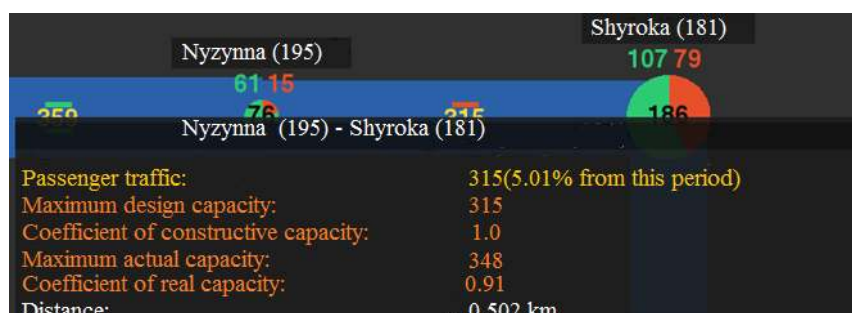

Figure 69: The data on the run between stops

General information about the route is displayed by clicking on the "General Information" button located in the upper right corner. An example of the window is shown in Fig. 70.

The next available mode is the mode of visual simulation "on the map" (Fig. 71), where according to the data on the time of traffic and passengers, is an accurate simulation of traffic during the day from stop to stop with the selection and disembarkation of passengers.

General information	
Volume of traffic:	21935 pas
Passenger turnover	52854.15 pas*km
Coefficient of variability of passengers:	2.41 km
Dynamic capacity utilization factor:	0.62
Passenger tension:	4137.51 pas.*km/h
Coefficient of uneven passenger traffic at the race	1.57
Coefficient of uneven passenger traffic over time:	1.62

Figure 70: General information window

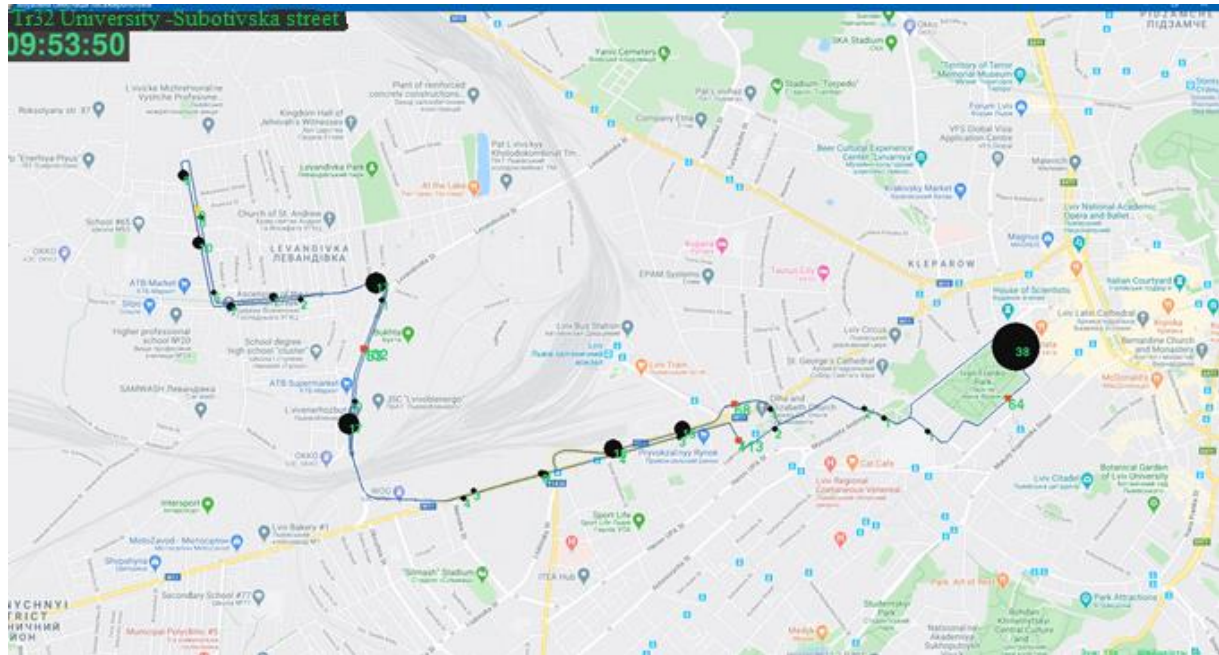

Figure 71: Map mode

This mode is most suitable for visual display where the map finds probably overloaded interchanges or particular vital objects of the city that attract people. Because the screen displays the exact time of day, you can see how many vehicles are currently on the route, track what is happening to them, set the car at lunch break, and determine if the car was moving too slowly than planned. This mode also supports zooming in and out (Fig. 72 - 73 respectively), slowing down the simulation speed by two and three times from ordinary. You can use the space bar to pause the simulation and explore this point in time.

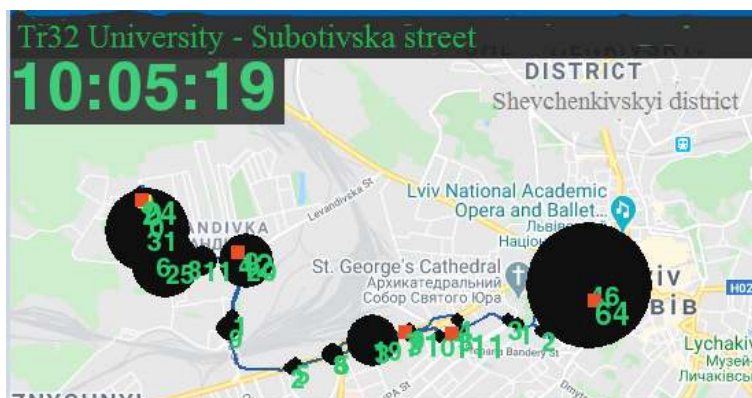

Figure 72: Example figure

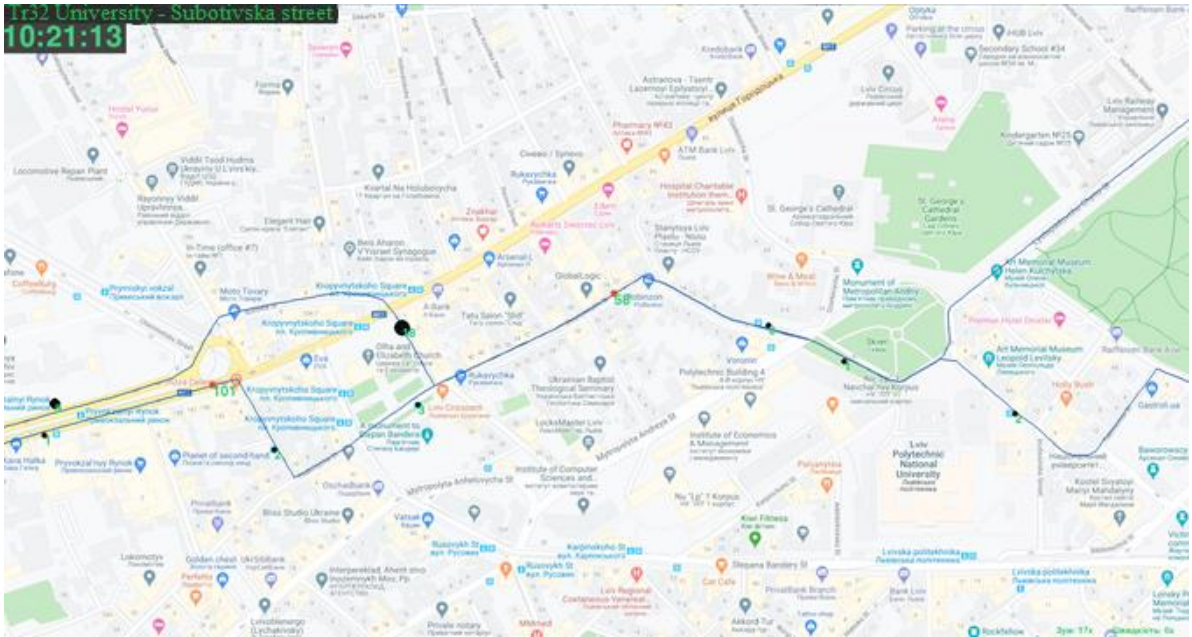

Figure 73: The most enormous scale

Red indicates the active vehicle on the route, yellow - if he is on a lunch break. At each stop, the number of passengers waiting for transport is indicated, and the circle's size means the stop in Fig. 74 (a). The larger the number of passengers, the larger the process. The size of the process changes dynamically between arrivals of transport, also at landing and disembarkation on fig. 74 (b).

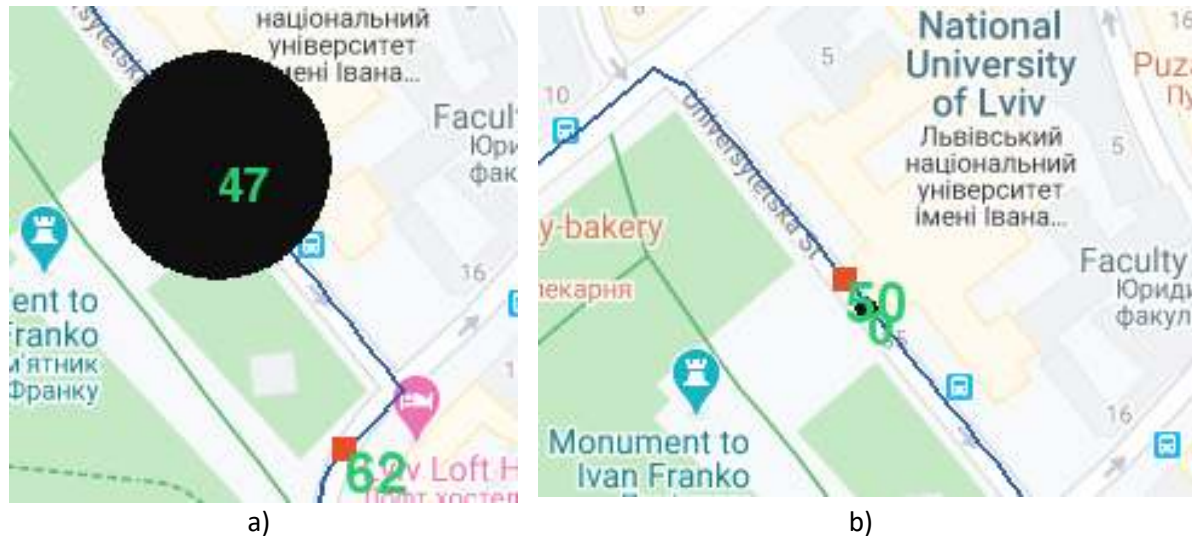

Figure 74: Type of visual simulation of the stop: a) before the arrival of the vehicle; b) after the arrival of the vehicle

Moving on the map in all directions is the arrows on the keyboard and zooming - the mouse wheel. The standard animation speed is calculated so that 1 minute of virtual time is simulated in 1 second of real-time. This speed can be reduced 2 and 3 times with the PageDown key and increase - PageUp. To start the possibility of predicting changes in passenger traffic using an additional vehicle, a separate block is used in the right part of the main menu in Fig. 75 (a). With its help, you can teach the neural network, after which it will be saved and will not require retraining in Fig. 75 (b). The program creates a file based on a template for presenting information in GTFS format, which must be filled in by the user with information about the new schedule of the additional vehicle. After clicking on the "Visualize schematically" key, the data on the capacity of the added transport in the window in Fig. 76. Then there is a recalculation of data on passenger traffic, which is displayed in schematic mode (Fig. 77).

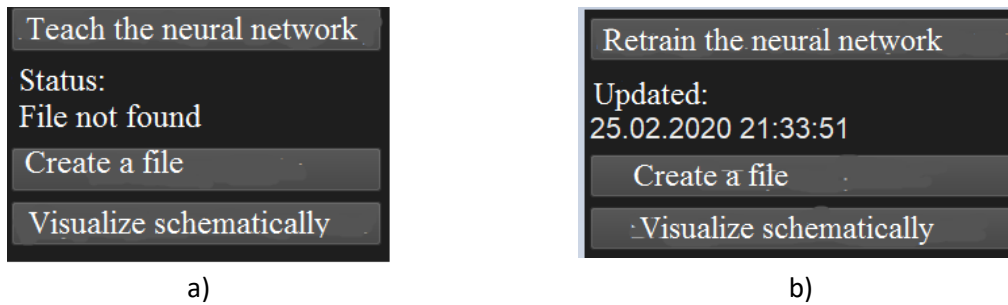

Figure 75: Blocks for interaction with the neural network: a) before learning; b) after

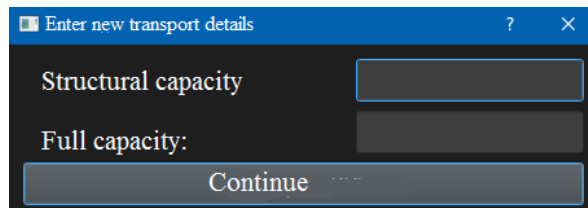

Figure 76: Window for entering vehicle capacities



Figure 77: Changed passenger flows

In this mode, the change in the colours of the race between stops affects forecasting changes in passenger traffic. Blue indicates no change or an area that has not covered by the additional vehicle. Green - indicates that passenger traffic has increased, and red - its decrease. This data presentation provides an opportunity to assess whether it will be cost-effective to add this vehicle or whether it may be necessary to adjust its schedule to better cover the loaded areas during peak hours.

The growth of passenger traffic is shown in Fig. 78, where the upper orange line indicates the predicted neural network. Fig. 78 shows an increase in passenger traffic from the sixth to the 13th race by an average of 28%, and in the races from 1 to 5, changes are almost non-existent.

Table 17 compares the change in passenger traffic, distributed by the race in the period from 19:00 to 20:00, according to actual data and after forecasting by the neural network. Of the 13 races, there are significant changes in only nine races. The other four remained unchanged (or with minimal changes). It will allow you to make an informed management decision to launch additional transport.



Figure 78: The schedule of loading of races by passenger flows

Table 17

Analysis of changes in passenger traffic during the race after the neural network in the period from 19:00 to 20:00

Race number	Actual	Predicted	Absolute change	Relative change
1	118	123	5	4.24%
2	67	79	12	17.91%
3	201	201	0	0.00%
4	344	346	2	0.58%
5	469	473	4	0.85%
6	432	506	74	17.13%
7	457	546	89	19.47%
8	460	559	99	21.52%
9	456	564	108	23.68%
10	483	587	104	21.53%
11	348	450	102	29.31%
12	294	397	103	35.03%
13	183	286	103	56.28%

Thus, this section provides a description of the developed software product according to clear rules and regulations according to GOST 19.402-78 "Description of the program". The user manual, which will be part of the technical documentation, accompanied by illustrations of the program, has been successfully created. This instruction is also performed according to the norms and according to the international standard IEEE STD 1063-2001 "Standard for Software User Documentation". To confirm the efficiency of development and compliance with the task, the analysis of the control example.

6. Economic substantiation of expediency of work

6.1. Economic characteristics of the software product

The work aims to improve the quality of passenger transport services in public transport. Since the basic unit for assessing passenger traffic is the passenger, it is necessary to conduct a study of passenger traffic to provide quality services. It is why there is a need to develop a software product that will

visually simulate passenger traffic and make predictions about changes in passenger traffic with a specific impact on the route under study at a particular time of day and a certain distance. The economic feasibility of software product development is that the subject of research, analysis, and evaluation of passenger flows is underdeveloped. In addition, the current software products that are currently on the market are too complex, which requires additional training of specialist staff to work with this software, which generates additional costs for the company.

Moreover, the critical factor is the high price of the given decisions, which cannot be blocked by profits from the received optimization or changes on routes in our realities. In addition, this software product comes with an intuitive interface and Ukrainian language, which will significantly facilitate the work with these software solutions. Currently, all other software products currently on the market contain only foreign languages. Therefore, this creates the marketing value of this product. Thus, summarizing the above, it is clear that the developed software product will have sufficient demand in the market today due to the availability of adequate necessary features and capabilities for future consumers and a simple and intuitive interface.

6.2. Economic characteristics of the software product

Currently, there is only one organization on the market in Ukraine that can provide services for research, evaluation, and analysis of passenger flows in the public transport field. However, this company only offers such services but does not sell its software product, which is for each application will have to pay extra. If we talk about the international market, one large company has been engaged in the visual simulation of passenger traffic for over 40 years. However, the price of this software product reaches tens of millions of hryvnias and requires additional specially trained staff to work with it. Similar products on the market are sold in different ways, and the most common is to provide a price for each buyer. It is impossible to find out which school the price is set for, generating some speculation in this market. Other products are sold at a price depending on the length of the routes you need to explore, which greatly increases the price for large companies or large cities. The primary consumers of this software product may be state-owned utilities, which manage most of the city's transport routes. It will be just as important for the city's high status and popularity among tourists and private companies, which have only a few ways but plan to get the highest possible quality of transport from passengers, to be able to develop and obtain more roads in the city. Competitors are currently not significantly grown in our market in the country, and therefore cannot create significant problems for the development of the current software product that will enter the market. In addition, this system does not require additional legislation and regulations that could somehow affect the development and distribution or pricing policy.

7. Conclusions

The problem of visual simulation of passenger flows in the field of public transport, which is studied in work, is relevant for the development of modern cities. To improve the quality of passenger services in the town, a software product has been created that allows you to visually simulate passenger traffic in actual conditions and predict their changes through the neural network when adding a schedule of additional vehicle. To solve the tasks in this paper, some existing on the market programs for passenger transportation and their comparative analysis and the existing available scientific developments in the field of public transport passenger traffic management. Significant advantages and disadvantages of known approaches, methods, tools and algorithms for solving problems of visual simulation of passenger traffic are highlighted. In this analysis, as a result, it was found that the critical task of public transport information systems is to assess passenger traffic.

Since passenger traffic is not a sufficiently researched topic in visual simulation, most scientific articles focus on assessing the quality of public transport. The main component of passenger traffic is the passenger, who can determine the quality of passenger transport.

Possibilities, availability, approaches and principles of optimization of passenger transportations are analysed. It is established that the visualization of passenger flows is one of the essential tasks of optimizing routes and improving the quality of passenger transport by public transport in Smart City.

It is established that at present, there is a need for research on the assessment and visual simulation of passenger traffic, the search for new approaches to solving problems.

In the research conducted in work, a tree of goals was created, constructed and described, in which all aspects and criteria for achieving the general goal are given. To specify the functioning of the developed system, a representation is created using functional diagrams IDEF0, which allowed estimating the scale of the software product that is planned for development, including all its reference points. Workflow diagrams, IDEF3, were used to display a specific sequence of actions, which allowed considering the processes that are planned to be implemented in the software product in more detail. With the help of specialized software, a hierarchy of tasks in the form of a tree is created, which shows the general order of information system processes.

Therefore, the system analysis resulting from the information system of visual simulation of passenger flows is offered. For the development of this information system, the choice of Python programming language is substantiated. Additional modules that are necessary for the correct development of the software product are described. The well-known standard of public transport data presentation - GTFS is used for the operation of the software. It allows you to make this software product universal rather than specific to a particular city or country. Own algorithms for dividing routes into forward and reverse sides, placement of stops on the way, and unique algorithms for visual simulation in the "map" and schematic modes are proposed and developed.

The capabilities of a fully connected neural network are used to predict changes in passenger traffic after the addition of an additional vehicle schedule. It provides an opportunity to indicate the shift in passenger traffic at the appropriate time on this segment of the route. This neural network makes it possible to optimize passenger transport by public transport in Smart City.

The paper also describes the created software product according to the relevant standards, user manual and a control example to confirm the efficiency of this development.

The passenger flows predicted by the neural network, in comparison with the actual ones, lead to their growth by an average of 28% in critical races at rush hour. These results substantiate the feasibility of adding a schedule of a new vehicle for better coverage of loaded areas during peak hours.

A comparison of changes in passenger traffic distributed over the races during the day from 19:00 to 20:00, according to current data and after the operation of the neural network indicates an increase in their average 70% of races that are predicted, which will allow making an informed management decision launch of additional transport on the route. Therefore, based on all of the above, the results are achieved in performing the work meet the goal, which is confirmed by the examples of the work of the developed software.

8. References

- [1] W. Li, W. Zhu, A dynamic simulation model of passenger flow distribution on schedule-based rail transit networks with train delays, volume 3(4) of *Journal of Traffic and Transportation Engineering*, 2016, pp. 364-373.
- [2] B. Bachelet, L. Yon, Enhancing theoretical optimization solutions by coupling with simulation, in: *Proceeding of the 1st OICMS, Clermont-Ferrand, France, 2005*, pp. 331-342.
- [3] I. M. Ryabov, R. Ya. Kashmanov, Improving the organization of passenger service on the route by using buses of different capacity, volume 16.3 of *SibADI Gazette*, 2019, pp. 264-275.
- [4] A. M. Voorhees, A General Theory of Traffic Movement, volume 40.6 of *Transportation*, 2013, pp. 1105-1116.
- [5] Y. Matseliukh, V. Vysotska, M. Bublyk, Intelligent System of Visual Simulation of Passenger Flows, volume Vol-2604 of *CEUR Workshop Proceedings*, 2020, pp. 906-920.
- [6] M. Bublyk, Y. Matseliukh, U. Motorniuk, M. Terebukh, Intelligent system of passenger transportation by autopiloted electric buses in Smart City, volume Vol-2604 of *CEUR Workshop Proceedings*, 2020, pp. 1280-1294.
- [7] L. Mochurad, N. Boyko, M. Bortnikova Parallel Approach of the Algorithm of Finding the Optimal Solution of the Transport Problem by the Method of Potentials, volume Vol-2604 of *CEUR workshop proceedings*, 2020, pp. 952-963.

- [8] W. Behiri, S. Belmokhtar-Berraf, Chu, Urban freight transport using passenger rail network: Scientific issues and quantitative analysis, volume 115 of *Transportation Research Part E: Logistics and Transportation Review*, 2018, pp. 227-245.
- [9] B. V. Kumar, A. Ravishankar, A. Karan, K. Vishal, J. A. P. Kumar, A Smart Public Transportation System for Reliable and Hassle Free Conveyance in Sustainable Smart Cities, in: *Proceedings of IEEE the International conference on Computer Communication and Informatics (ICCCI)*, 2020, pp. 1-6.
- [10] Yu. A. Koleber, Informational support of optimization tasks for the public passenger transport route network of major and major cities: relevance and approaches, volume 15.2 of *SibADI Gazette*, 2018, pp. 218-228.
- [11] M. H. Nguyen, T. T. Ha, S. S. Tu, T. C. Nguyen, Impediments to the bus rapid transit implementation in developing countries – a typical evidence from Hanoi, volume 23.4 of *International Journal of Urban Sciences*, 2019, 464-483. doi: 10.1080/12265934.2019.1577747.
- [12] M. Bublyk, V. Vysotska, Y. Matseliukh, V. Mayik, M. Nashkarska, Assessing losses of human capital due to man-made pollution caused by emergencies, volume Vol-2805 of *CEUR Workshop Proceedings*, 2020, pp. 74-86.
- [13] Y. Han, C. Wang, Y. Ren, S. Wang, H. Zheng, G. Chen, Short-term prediction of bus passenger flow based on a hybrid optimized LSTM network, volume 8.9 of *ISPRS International Journal of Geo-Information*, 2019, p. 366. <https://doi.org/10.3390/ijgi8090366>.
- [14] L. Podlesna, M. Bublyk, I. Grybyk, Y. Matseliukh, Y. Burov, P. Kravets, O. Lozynska, I. Karpov, I. Peleshchak, R. Peleshchak, Optimization model of the buses number on the route based on queueing theory in a smart city, volume Vol-2631 of *CEUR Workshop Proceedings*, 2020, pp. 502-515.
- [15] T. T. H. Nguyen, I. M. Ryabov, Features of logistics of public passenger transport of Hanoi, volume 6 of *Symbol of science*, 2018, pp. 53-59.
- [16] O. Y. Boreiko, V. M. Teslyuk, A. Zelinsky, O. Berezsky, Development of models and means of the server part of the system for passenger traffic registration of public transport in the "smart" city, volume 1(2-85) of *Eastern-European Journal of Enterprise Technologies*, 2017, pp. 40-47.
- [17] A. Kazarian, V. Teslyuk, I. Tsmots, M. Tykhan, Implementation of the Face Recognition Module for the "Smart" Home Using Remote Server, volume 871 of *Advances in Intelligent Systems and Computing III*, AISC, Springer, 2019, pp. 17-27.
- [18] D. Koshtura, M. Bublyk, Y. Matseliukh, D. Dosyn, L. Chyrun, O. Lozynska, I. Karpov, I. Peleshchak, M. Maslak, O. Sachenko, Analysis of the demand for bicycle use in a smart city based on machine learning, volume Vol-2631 of *CEUR workshop proceedings*, 2020, pp. 172-183.
- [19] I. V. Chumachenko, Yu. A. Davidich, A. S. Galkin, N. V. Davidich, Evaluation of the quality of passenger transportation by public transport at different number of vehicles operating on the route, volume 16.5 of *Science and technology*, 2017, pp. 415-421.
- [20] J. J. Cronin, S. A. Taylor, *Measuring Service Quality: a Reexamination and Extension*, volume 56.3 of *Journal of Marketing*, 1992, pp. 55-68.
- [21] A. Parasuraman, V. A. Zeithaml, L. L. Berry, *SERVQUAL: a Multiple Item Scale for Measuring Consumer Perceptions of Service Quality*, volume 64.1 of *Journal of Retailing*, 1988, pp. 12-37.
- [22] I. Krislata, A. Katrenko, V. Lytvyn, V. Vysotska, Y. Burov, Traffic flows system development for smart city, volume Vol-2565 of *CEUR Workshop Proceedings*, 2020, pp. 280-294.
- [23] O. Kuzmin, M. Bublyk, A. Shakhno, O. Korolenko, H. Lashkun, Innovative development of human capital in the conditions of globalization, volume 166 of *E3S Web of Conferences*, 2020, p. 13011. doi:10.1051/e3sconf/202016613011
- [24] I. Bodnar, M. Bublyk, O. Veres, O. Lozynska, I. Karpov, Y. Burov, P. Kravets, I. Peleshchak, O. Vovk, O. Maslak, Forecasting the risk of cervical cancer in women in the human capital development context using machine learning, volume Vol-2631 of *CEUR Workshop Proceedings*, 2020, pp. 491-501.
- [25] G. Beirão, J. S. Cabral, Enhancing Service Quality in Public Transport Systems, in: *Faculty of Engineering. XII: Urban Transport and the Environment in the 21st Century*, 2006, pp. 837-845.
- [26] M. Friman, M. Fellesson, Service Supply and Customer Satisfaction in Public Transportation: the Quality Paradox, volume 12.4 of *Journal of Public Transportation*, 2009, pp. 57-69.

- [27] O. Soprun, M. Bublyk, Y. Matseliukh, V. Andrunyk, L. Chyrun, I. Dyyak, A. Yakovlev, M. Emmerich, O. Osolinsky, A. Sachenko, Forecasting temperatures of a synchronous motor with permanent magnets using machine learning, volume Vol-2631 of CEUR Workshop Proceedings, 2020, pp. 95-120.
- [28] E. Marcucci, E. Valeri, A. Stathopoulos, V. Gatta, Local public transport, service quality and tendering contracts in Venezia, in: *Urban Sustainable Mobilità*, Milan, 2011, pp. 1-14.
- [29] M.H. Nguyen, Evaluating the Service Quality of the First Bus Rapid Transit Corridor in Hanoi City and Policy Implications, volume 108 of *Lecture Notes in Civil Engineering*, Springer-Verlag, London, 2021, pp. 98-123.
- [30] T. K. Ojo, D. O. Mireku, S. Dauda, Service Quality and customer satisfaction of public transport on Cape Coast-Accra Route, volume 4.18 of *Ghana, Developing Country Studies*, 2014, pp. 142-149.
- [31] G. C. Bezerra, C. F. Gomes, The effects of service quality dimensions and passenger characteristics on passenger's overall satisfaction with an airport, volume 44 of *Journal of Air Transport Management*, 2015, pp. 77-81.
- [32] M. Bublyk, V. Lytvyn, V. Vysotska, L. Chyrun, Y. Matseliukh, N. Sokulska, The decision tree usage for the results analysis of the psychophysiological testing, volume Vol-2753 of CEUR Workshop Proceedings, 2020, pp. 458-472.
- [33] O. Maslak, M. Maslak, N. Grishko, Y. Shevchuk, Tool development for the assessment of the favorable environment in the framework of the investment policy formation for the electrotechnical industry enterprises, in: *Proceedings of the 25th IEEE International Conference on Problems of Automated Electric Drive. Theory and Practice, PAEP, 2020*. doi:10.1109/PAEP49887.2020.9240840.
- [34] Q. Yu, H. Zhang, W. Li, X. Song, D. Yang, R. Shibasaki, Mobile phone GPS data in urban customized bus: Dynamic line design and emission reduction potentials analysis, volume 272 of *Journal of Cleaner Production*, 2020, p. 122471.
- [35] N. Antonyuk, A. Vysotsky, V. Vysotska, V. Lytvyn, Y. Burov, A. Demchuk, I. Lyudkevych, L. Chyrun, S. Chyrun, I. Bobyk, Consolidated Information Web Resource for Online Tourism Based on Data Integration and Geolocation, in: *Proceedings of the IEEE 14th International Scientific and Technical Conference on Computer Science and Information Nechnologies, CSIT, 2019*, pp.15-20.
- [36] M. H. Nguyen, T. T. Ha, T. L. Le, T. C. Nguyen, Challenges to development of bus system evidence from a comparative analysis of surveys in Hanoi, in: *Transportation for a Better Life: Mobility and Road Safety Managements*, Bangkok, Thailand, 2017, pp. 1-10.
- [37] I. Rishnyak, O. Veres, V. Lytvyn, M. Bublyk, I. Karpov, V. Vysotska, V. Panasyuk, Implementation models application for IT project risk management, volume Vol-2805 of CEUR Workshop Proceedings, 2020, pp. 102-117.
- [38] A. Katrenko, I. Krislata, O. Veres, O. Oborska, T. Basyuk, A. Vasyliuk, I. Rishnyak, N. Demyanovskyi, O. Meh, Development of Traffic Flows and Smart Parking System for Smart City, volume Vol-2604 of CEUR workshop proceedings, 2020, pp. 730-745.
- [39] V. Aliexsieiev, B. Markovych, Implementation of UAV for environment monitoring of a Smart City with an airspace regulation by AIXM-format data streaming, volume 5(2/2020) of *Scientific-Technical Union of Mechanical Engineering "Industry 4.0"*, Sofia, Bulgaria, 2020, pp. 90-93. URL: <https://stumejournals.com/journals/i4/2020/2/90>
- [40] N. Kunanets, H. Matsiuk, Use of the Smart City Ontology for Relevant Information Retrieval, volume Vol-2362 of CEUR Workshop Proceedings, 2019, pp. 322-333.
- [41] A. Fomenko, V. Vyshnia, Specialized Automated System for Control and Support of Rail Cargo Transportation, volume 18(2) of *International Journal of Computing*, 2019, pp. 191-200.
- [42] R. Nallusamy, K. Duaiswamy, R. Dhanalaksmi, Optimization of multiple vehicle routing problems using approximation algorithms, volume 1.3 of *International Journal of Engineering Science and Technology*, 2009, pp. 129-135.
- [43] V. Lytvynenko, N. Savina, J. Krejci, M. Voronenko, M. Yakobchuk, O. Kryvoruchko, Bayesian Networks' Development Based on Noisy-MAX Nodes for Modeling Investment Processes in Transport, volume Vol-2386 of CEUR Workshop Proceedings, 2019, pp. 1-10.

- [44] M. Vovk, P. Pukach, O. Hentosh, Ya. Prykarpatsky, The Structure of Rationally Factorized Lax Type Flows and their Analytical Integrability, volume 16 of WSEAS Transactions on Mathematics, 2017, pp. 322-330.
- [45] K. Liu, C. Zhai, Y. Dong, Optimal restoration schedules of transportation network considering resilience, in: Structure and Infrastructure Engineering, 2020, pp. 1-14.
- [46] S. Basu, B. Bundick, Uncertainty shocks in a model of effective demand, volume 85(3) of *Econometrica*, 2017, pp. 937-958.
- [47] B. Yao, P. Hu, X. Lu, J. Gao, M. Zhang, Transit network design based on travel time reliability, volume 43 of *Transportation Research Part C: Emerging Technologies*, 2014, pp. 233-248.
- [48] M. Esposito, K. Lindenberg, C. Van den Broeck, Entropy production as correlation between system and reservoir, volume 12(1) of *New Journal of Physics*, 2010, p. 013013.
- [49] M. Sharov, Improving Methods of Estimation of Transport Demand for Urban Passenger Transportation, in: *Proceedings of the International Conference on Aviaemechanical Engineering and Transport*, AviaENT, Atlantis Press, 2019, pp. 298-301.
- [50] A. Terentyev, S. Evtyukov, M. Karelina, Methods of optimization of motor transportation processes, volume 334 of *ATEC Web of Conferences*, EDP Sciences, 2021.
- [51] A. Chen, Z. Zhou, P. Chootinan, S. Ryu, C. Yang, S. C. Wong, Transport network design problem under uncertainty: a review and new developments, volume 31(6) of *Transport Reviews*, 2011, pp. 743-768.
- [52] O. Murzenko, S. Olszewski, O. Boskin, I. Lurie, N. Savina, M. Voronenko, V. Lytvynenko, Application of a Combined Approach for Predicting a Peptide-Protein Binding Affinity Using Regulatory Regression Methods with Advance Reduction of Features, in: *Proceedings of the 10th IEEE International Conference on Intelligent Data Acquisition and Advanced Computing Systems: Technology and Applications*, IDAACS, 2019, pp. 431-435. doi:10.1109/IDAACS.2019.8924244
- [53] K. Andreev, V. Terentyev, Development of strategies for the development of urban passenger transport in EurAsEC countries, volume 135 of *E3S Web of Conferences*, EDP Sciences, 2019, p. 02013.
- [54] A. Burlutsky, G. Pushkareva, E. Kirgisarova, Development of approach to improvement of urban traffic flow diagram, volume 216 of *MATEC Web of Conferences*, EDP Sciences., 2018, p. 02026.
- [55] B. Yu, Z. Yang, Optimizing bus transit network with parallel ant colony algorithm, in: *Proceedings of the Eastern Asia Society for Transportation Studies*, volume 5, 2005, pp. 374-389.
- [56] O. Cyprich, V. Konečný, K. Kilianova, Short-term passenger demand forecasting using univariate time series theory, volume 25(6) of *PROMET-Traffic&Transportation*, 2013, pp. 533-541.
- [57] Sh. Afandizadeh, H. Khaksar, N. Kalantari, Bus fleet optimization using genetic algorithm a case study of Mashhad, volume 11 of *International Journal of Civil Engineering*, 2012, pp. 43-52.
- [58] A. Álvarez, S. Casado, J. G. Velarde, J. Pacheco, A computational tool for optimizing the urban public transport: A real application, volume 49(2) of *Journal of computer and systems sciences international*, 2010, pp. 244-252.
- [59] J. C. Pérez, M. H. Carrillo, J. R. Montoya-Torres, Multi-criteria approaches for urban passenger transport systems: a literature review, volume 226(1) of *Annals of operations research*, 2015, pp. 69-87.
- [60] Y. Zhongzhen, Y. Bin, C. Chuntian, A parallel ant colony algorithm for bus network optimization, volume 22 of *Computer-Aided Civil and Infrastructure Engineering*, 2007, pp. 44-55.
- [61] A. Vysotsky, V. Lytvyn, V. Vysotska, D. Dosyn, I. Lyudkevych, N. Antonyuk, O. Naum, A. Vysotskyi, L. Chyrun, O. Slyusarchuk, Online Tourism System for Proposals Formation to User Based on Data Integration from Various Sources, in: *Proceedings of the IEEE 14th International Scientific and Technical Conference on Computer Science and Information Technologies*, CSIT, 2019, pp. 92-97.
- [62] Y. Matseliukh, V. Vysotska, M. Bublyk, T. Kopach, O. Korolenko, Network Modelling of Resource Consumption Intensities in Human Capital Management in Digital Business Enterprises by the Critical Path Method, volume Vol-2851 of *CEUR Workshop Proceedings*, 2021, pp. 366-380.
- [63] J. Su, A. Sachenko, V. Lytvyn, V. Vysotska, D. Dosyn, Model of Touristic Information Resources Integration According to User Needs, in: *Proceedings of the IEEE 13th International Scientific and*

- Technical Conference on Computer Sciences and Information Technologies, CSIT, 2018, 2, pp. 113-116.
- [64] K. Bazilevych, M. Mazorchuk, Y. Parfeniuk, V. Dobriak, I. Meniailov, D. Chumachenko, Stochastic Modelling of Cash Flow for Personal Insurance Fund Using the Cloud Data Storage, volume 17(3) of International Journal of Computing, 2018, pp. 153-162.
- [65] V. Vysotska, V. Lytvyn, Y. Burov, A. Gozhyj, S. Makara, The consolidated information web-resource about pharmacy networks in city, volume Vol-2255 of CEUR Workshop Proceedings, 2018, pp. 239-255.
- [66] V. Vysotska, M. Bublyk, A. Vysotsky, A. Berko, L. Chyrun, K. Doroshkevych, Methods and tools for web resources processing in E-commercial content systems, in: Proceedings of the IEEE 15th International Scientific and Technical Conference on Computer Sciences and Information Technologies, CSIT, 1, 2020, pp. 114-118, 9321950. doi:10.1109/CSIT49958.2020.9321950
- [67] A. Berko, I. Pelekh, L. Chyrun, M. Bublyk, I. Bobyk, Y. Matseliukh, L. Chyrun, Application of ontologies and meta-models for dynamic integration of weakly structured data, in: Proceedings of the 2020 IEEE 3rd International Conference on Data Stream Mining and Processing, DSMP, 2020, pp. 432-437. doi: 10.1109/DSMP47368.2020.9204321
- [68] M. Bublyk, V. Lytvyn, V. Vysotska, N. Sokulska, L. Chyrun, Y. Matseliukh, The decision tree usage for the results analysis of the psychophysiological testing, volume Vol-2753 of CEUR Workshop Proceedings, Växjö, Sweden, 2020, pp. 458-472.
- [69] V. Lytvyn, A. Hryhorovych, V. Hryhorovych, V. Vysotska, M. Bublyk, L. Chyrun, Medical content processing in intelligent system of district therapist, volume Vol-2753 of CEUR Workshop Proceedings, Växjö, Sweden, 2020, pp. 415-429.
- [70] V. Vysotska, V. Lytvyn, M. Bublyk, A. Demchuk, L. Demkiv, Y. Shpak, Method of ontology quality assessment for knowledge base in intellectual systems based on ISO/IEC 25012, in: Proceedings of the IEEE 15th International Scientific and Technical Conference on Computer Sciences and Information Technologies, CSIT, 1, 2020, pp. 109-113.
- [71] P. Kravets, V. Lytvyn, V. Vysotska, Y. Burov, I. Andrusyak, Game Task of Ontological Project Coverage, volume Vol-2851 of CEUR Workshop Proceedings, 2021, pp. 344-355.
- [72] V. Lytvyn, I. Peleshchak, V. Vysotska, R. Peleshchak, Satellite spectral information recognition based on the synthesis of modified dynamic neural networks and holographic data processing techniques, in: Proceedings of the International Conference on Computer Sciences and Information Technologies, CSIT, 2018, pp. 330-334.
- [73] P. Kravets, Y. Burov, O. Oborska, V. Vysotska, L. Dzyubyk, V. Lytvyn, Stochastic Game Model of Data Clustering, volume Vol-2853 of CEUR Workshop Proceedings, 2021, pp. 214-227.
- [74] Y. Kis, L. Chyrun, T. Tsybaliak, L. Chyrun, Development of System for Managers Relationship Management with Customers, volume 1020 of Lecture Notes in Computational Intelligence and Decision Making, 2020, pp. 405-421.
- [75] L. Chyrun, A. Kowalska-Styczen, Y. Burov, A. Berko, A. Vasevych, I. Pelekh, Y. Ryshkovets, Heterogeneous Data with Agreed Content Aggregation System Development, volume Vol-2386 of CEUR Workshop Proceedings, 2019, pp. 35-54.
- [76] L. Chyrun, L. Chyrun, Y. Kis, L. Rybak, Automated Information System for Connection to the Access Point with Encryption WPA2 Enterprise, volume 1020 of Lecture Notes in Computational Intelligence and Decision Making, 2020, pp. 389-404.
- [77] O. Klymovych, V. Hrabchak, O. Lavrut, T. Lavrut, V. Lytvyn, V. Vysotska, The Diagnostics Methods for Modern Communication Tools in the Armed Forces of Ukraine Based on Neural Network Approach, volume Vol-2631 of CEUR Workshop Proceedings, 2020, pp. 198-208.
- [78] M.O. Medykovskyi, I.G. Tsmots, Y.V. Tsybalyak, Information analytical system for energy efficiency management at enterprises in the city of Lviv (Ukraine), volume 175(1) of Actual Problems of Economics, 2016, pp. 379-384.
- [79] V. Golovko, Y. Savitsky, T. Laopoulos, A. Sachenko, L. Grandinetti, Technique of learning rate estimation for efficient training of MLP, in: Proceedings of the International Joint Conference on Neural Networks, 1, 2000, pp. 323-328.
- [80] C. Shu, D. Dosyn, V. Lytvyn, V. Vysotska, A. Sachenko, S. Jun, Building of the Predicate Recognition System for the NLP Ontology Learning Module. Proceedings of the 10th IEEE

- International Conference on Intelligent Data Acquisition and Advanced Computing Systems: Technology and Applications, IDAACS, 2, 2019, pp. 802-808.
- [81] A. Sachenko, V. Kochan, V. Turchenko, Intelligent distributed sensor network, in: Conference Record - IEEE Instrumentation and Measurement Technology Conference 1, 1998, pp. 60-664.
- [82] A. Sachenko, V. Kochan, R. Kochan, V. Turchenko, K. Tsahouridis, T. Laopoulos, Error compensation in an intelligent sensing instrumentation system, in: Proceedings of the Conference Record - IEEE Instrumentation and Measurement Technology Conference, 2, 2001, pp. 869-874.
- [83] R. Kochan, K. Lee, V. Kochan, A. Sachenko, Development of a dynamically reprogrammable NCAP. Proceedings of the Conference Record – IEEE Instrumentation and Measurement Technology Conference, 2, 2004, pp. 1188-1192.
- [84] V. Lytvyn, A. Kowalska-Styczen, D. Peleshko, T. Rak, V. Voloshyn, J. R. Noennig, V. Vysotska, L. Nykolyshyn, H. Pryshchepa, Aviation Aircraft Planning System Project Development, volume 1080 of Advances in Intelligent Systems and Computing IV, Springer, Cham, 2020, pp. 315-348.
- [85] S. Babichev, An Evaluation of the Information Technology of Gene Expression Profiles Processing Stability for Different Levels of Noise Components, volume 3 of Data, 2018, art. 48.
- [86] S. Babichev, B. Durnyak, I. Pikh, V. Senkivskyy, An Evaluation of the Objective Clustering Inductive Technology Effectiveness Implemented Using Density-Based and Agglomerative Hierarchical Clustering Algorithms, volume 1020 of Advances in Intelligent Systems and Computing, 2020, pp. 532-553.
- [87] V. Lytvynenko, N. Savina, M. Pyrtko, M. Voronenko, R. Baranenko, I. Lopushynskiy, Development, validation and testing of the Bayesian network to evaluate the national law enforcement agencies' work, in: Proceedings of the 9nd Int. Conf. on Advanced Computer Information Technologies, ACIT, 2019, pp. 252-256.
- [88] V. Lytvynenko, N. Savina, J. Krejci, M. Voronenko, M. Yakobchuk, O. Kryvoruchko, Bayesian Networks' Development Based on Noisy-MAX Nodes for Modeling Investment Processes in Transport, volume Vol-2386 of CEUR Workshop Proceedings, 2019, pp. 1-10.
- [89] V. Lytvynenko, I. Lurie, M. Voronenko, N. Savina, J. Krejci, A. Fefelov, I. Lopushynskiy, P. Vorona, The use of Bayesian methods in the task of localizing the narcotic substances distribution, in: Proceedings of the IEEE-2019 14th International Scientific and Technical Conference on Computer Sciences and Information Technologies, CSIT, 2019, pp. 60-63.
- [90] V. Lytvynenko, N. Savina, M. Voronenko, N. Doroschuk, S. Smailova, O. Boskin, T. Kravchenko, Development, Validation and Testing of the Bayesian Network of Educational Institutions Financing, in: Proceedings of the crossing point of Intelligent Data Acquisition & Advanced Computing Systems and East & West Scientists, IDAACS, 2019, pp. 412-418.
- [91] V. Lytvynenko, N. Savina, M. Voronenko, A. Pashnina, R. Baranenko, N. Krugla, I. Lopushynskiy, Development of the Dynamic Bayesian Network to Evaluate the National Law Enforcement Agencies' Work, in: Proceedings of the crossing point of Intelligent Data Acquisition & Advanced Computing Systems and East & West Scientists, IDAACS, 2019, pp. 418-424.