

PAPER • OPEN ACCESS

Development of light and highly radiation transparent cryostats for FCC detector magnets: first analyses of insulation materials

To cite this article: V Ilardi *et al* 2019 *IOP Conf. Ser.: Mater. Sci. Eng.* **502** 012083

View the [article online](#) for updates and enhancements.



IOP | ebooks™

Bringing you innovative digital publishing with leading voices to create your essential collection of books in STEM research.

Start exploring the collection - download the first chapter of every title for free.

Development of light and highly radiation transparent cryostats for FCC detector magnets: first analyses of insulation materials

V Ilardi^{1,2}, H Silva¹, A Dudarev¹, T Koettig¹, P Borges de Sousa¹, L N Busch¹, T Kulenkampff^{1,3}, E R Bielert¹ and H H J ten Kate¹

¹ CERN, Geneva, Switzerland

² University of Twente, Faculty of Science and Technology, Enschede, The Netherlands

³ Technical University of Vienna, Vienna, Austria

Email corresponding author: veronica.ilardi@cern.ch

Abstract. For both versions of the Future Circular Collider, the electron-positron FCC ee^+ , requiring a 2 T/4 m bore solenoid for particles spectrometry, and the hadron-hadron FCC hh, CERN is developing an innovative design for the detector solenoids, to enable their positioning inside the calorimeters directly surrounding the inner tracker. For this to happen, the cryostat design has to be optimized to achieve minimum radiation length. The novel design consists of a sandwich of thin inner and outer metallic shells for vacuum tightness, supported by an insulating material with sufficient mechanical resistance paired with lowest thermal conductivity, like Cryogel, a flexible aerogel structure (density 0.16 g/cm³), or glass spheres (e.g. type K1 manufactured by 3M, with 65 μ m diameter and density of 0.125 g/cm³). These materials would allow constructing a 4 m bore, 6 m long cryostat with a 250 mm total thickness, a heat load less than 400 W on the cold mass and 10 kW on the thermal shield. In this paper, design options are discussed and methods for qualifying the materials presented.

1. Introduction

The Future Circular Collider Study (FCC) features various design studies for circular colliders for the post-LHC era [1]. The first step may be FCC- ee^+ , a high-luminosity, high-precision electron-positron collider. In a new 100 km tunnel, the accessible centre-of-mass energy spans the range from 90 to 400 GeV. FCC- ee^+ could be the first step towards the long-term goal of a 100 TeV proton-proton collider, the FCC-hh.

For the particle detector magnets, designs are considered evolving from the detector magnets known from LHC experiments: CMS (Compact Muon Solenoid) with both inner tracker and hadron calorimeter inside the 4 T solenoid, to avoid the problem of insufficient radiation transparency typical for high field detector magnets [2], and ATLAS with a Central Solenoid that directly surrounds the inner tracker and thus positioned inside the calorimeter [3]. FCC- ee^+ intends to reach a 2 T magnetic field using, either a 6 m diameter solenoid enclosing both the inner tracker and the hadron calorimeter (HCAL) or, an extremely thin and strong 2 T solenoid with a 4 m bore, placed inside the HCAL. The current baseline design for the FCC-hh detector shows a 10 m free bore 4 T solenoid, with a length of 20 m. In addition, another two solenoids, or dipoles magnets, are positioned around the beam at each side of the main solenoid, providing particle bending power in the forward directions [1]. A second, much more



challenging design features an ultra-thin, high stress solenoid for 4 T in a 4 m free bore, to be positioned immediately around the detector's inner tracker [1].

Here, the focus is on the second solution. This requires the solenoid and its cryostat to have an extremely high transparency, in order to minimize particle scattering, and therefore low thickness and density. As a consequence, materials with high mechanical resistance are needed. Two development routes are pursued: first is to minimize the material thickness in a classical cryostat [4], second is subject of this paper. The concept is to replace the classical sandwich comprising vacuum vessel, radiation shield, MLI and cold mass, with a structure of very thin vacuum vessel walls, supported by a material providing thermal insulation and structural support. A few innovative materials may satisfy the characteristics requested. The first, Cryogel, is a flexible aerogel composite blanket, with a factory-applied vapour barrier, designed for insulating cold temperature environments ranging from cryogenic to ambient. It combines silica aerogel with reinforcing fibres and has a density of 0.16 g/cm^3 [5].

The second option is a volume of glass spheres, for example the K1 type manufactured by 3M. It has a 0.125 g/cm^3 density and, at room temperature, a calculated 0.047 W/mK thermal conductivity [6]. In this case, the cryostat wall would be fully filled by free spheres, which have to sustain under vacuum the external pressure of 1 atm. The thermal properties of these materials, under vacuum and at cryogenic temperature, are not sufficiently known.

First, we present the thermal study conducted on Cryogel so far. It includes a first thermal conductivity test performed on the material under a blanket compression of 30% and a temperature between 3 and 300 K. Also ANSYS simulations are reported to predict its behaviour for the FCC-ee⁺ cryostat case, heat loads expected on cold mass and thermal shield and the energy costs involved. The eventual use of outer surface heaters to keep the cryostat free of condensation is considered as well.

Second, we present the design realized for a new test setup comprising a model cryostat, thermal shield and cold mass, which can be filled with either Cryogel or glass spheres in order to measure their thermal conductivity on a larger scale and inside a structure that better represents a real cryostat.

2. Thermal conductivity measurements on Cryogel

In the Cryolab facility of CERN, the thermal conductivity of Cryogel Z, manufactured by Aspen Aerogels, was measured at temperatures between 3 and 300 K and applying a pressure between 10^{-7} and 10^{-8} mbar. The samples were compacted by pressure, giving a height reduction of 30%.

2.1. Sample characteristics and test set-up

The measurements were conducted on two discs cut out of a sheet of Cryogel Z with a 22 mm diameter and a 10 mm thickness. Each cylinder includes a layer of aluminum foil on one side.

The two samples were assembled onto a symmetrical sample holder consisting of three copper plates. The top and the bottom plates were kept at low temperature (about 3 K), while the middle one was gradually heated up. Thermal contact and compression force on the discs are provided by three copper braids bolted to the plates using brass bolts and copper-beryllium Belleville washers. The heated plate is in contact only with the two Cryogel cylinders on the aluminum layer side, so that the sample is thermally decoupled from the rest of the set-up, since there is also no heat conduction between sample, braids and bolts. This ensures that the heat is transferred only through the Cryogel discs. The low temperature side of the samples is in contact with a stainless steel plate for representing the walls of the vacuum vessel. The cut-Cryogel discs are compressed in transverse direction, from originally 10 mm to an effective thermal length L of 6.9 mm, corresponding to 30% densification. The measurement setup further includes a Sumitomo two-stage pulse tube refrigerator (PTR) delivering up to 1.0 W of cooling power at 4.2 K on the second stage [7]. The sample holder was bolted to the second stage of the PTR, using Apiezon N as interposer to promote a homogeneous thermal contact. The second stage has its own thermal shield made of copper and wrapped in MLI to minimize radiative loss. The first stage of the PTR was kept between 25 and 35 K. Figure 1 shows the sample holder and the two Cryogel discs.

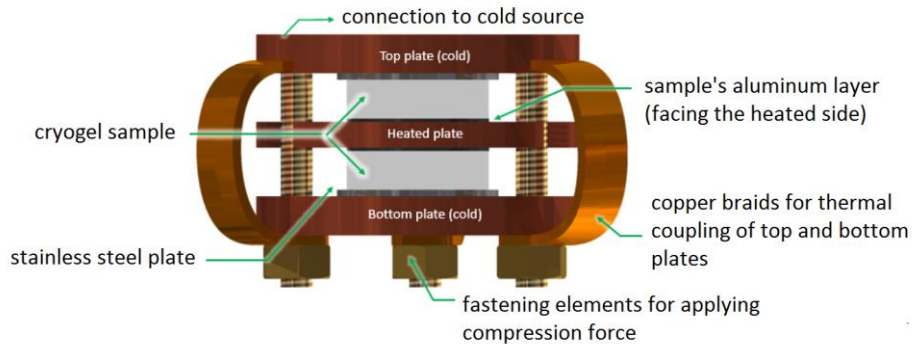

Figure 1. Sample holder for Cryogel thermal conductivity measurements.

The second stage temperature is initially set at 2.6 K and the heat load on the heated plate is incrementally increased. The temperature on the middle plate went up to 273 K, while the one on the cold plates was kept almost constant during the measurements. The top plate temperature varied from 2.6 to 5.7 K and the bottom plate temperature between 2.6 and 9.3 K, due to the high heat load applied. The heat load of 0 to 425 mW is provided by a 100 Ω electric heater glued with epoxy resin to the center plate. A calibrated TVO temperature sensor is positioned on the bottom plate, while two Cernox sensors are placed both on the top and middle plates, both calibrated against the TVO.

2.2. Measurement results

The results, shown in Table 1, take into account some corrections of the effective heat load transferred across the samples. Heat loss by radiation of the middle plate to the inner thermal shield was found to be 8.2% of the applied heating power for the highest temperature gradient (when plate at 273 K). The conduction loss through both Cernox sensor and electric heater placed on the center plate was less than 3% of the applied heat load for the measured range.

Table 1. Measured thermal conductivity data of Cryogel Z.

Temperature (K)	Thermal conductivity $\times 10^{-4}$ (W/mK)
10.0	2.10
17.1	5.97
23.7	9.15
42.6	16.7
102.1	41.3
190.9	164
249.5	370
269.1	471
273.6	496

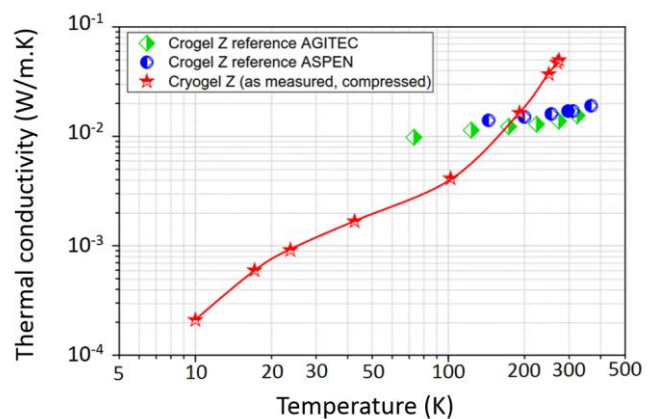

Figure 2. Measured thermal conductivity data compared to data given by manufacturers of Cryogel [5, 8].

In Figure 2 the results obtained are compared to the data given by manufacturers [5, 8]. The estimated measuring error is 30%. We see significant differences that may be explained by the different test conditions. First, we assume there was little or no compression on the samples measured by the manufactures. Second, the thermal conductivity of aerogel-based materials heavily depends on the gaseous environment. While our sample was measured in vacuum, the manufactures may have used different pressure and other gases. The 10-300K results can be considered reliable.

3. Heat load of cryostat using Cryogel

Now that the thermal properties under vacuum and at cryogenic temperatures of Cryogel Z were measured, the FCC-ee⁺ case was analysed to estimate the cryostat heat loads. A straightforward 4 m bore, 6 m long cryostat model was realized in ANSYS, comprising a sandwich of vacuum vessel walls, thermal shield, cold mass and Cryogel Z. Critical thicknesses are included in Figure 3.

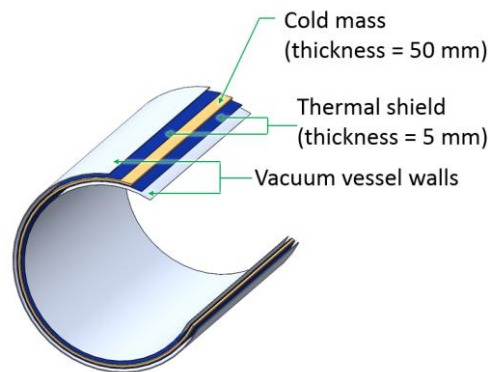

Figure 3. Simplistic model of the FCC-ee⁺ cryostat for a 2 T, 4 m free bore, 6 m long solenoid.

For probing a light and radiation thin cryostat, the thermal analyses was conducted for various cryostat wall thicknesses in the range of 150 to 500 mm. For each thickness, the heat loads expected on cold mass and thermal shield were calculated, considering a temperature of 4 K on the cold mass, 50 K on the thermal shield and 293 K on the cryostat outer skin of thin metallic plate.

The running power cost to cool the cryostat was calculated taking into account the heat loads involved. The optimum position of the thermal shield was analysed in order to minimize power cost. A 250 mm thick cryostat was considered a good solution from a first analysis, combining the two requirements of low thickness and lowest possible thermal load. The results are shown in Table 2. To minimize power cost, the thermal shield has to be positioned at 25 mm from the cold mass.

Table 2. Results of the numerical analysis on a 250 mm thick cryostat for the FCC-ee⁺ case.

Total heat load on the cold mass (W)	Total heat load on the thermal shield (kW)	Energy cost (kW)
390	10	400

The last aspect of interest is the eventual use of outer surface heaters to avoid air condensation on the skin of the cryostat vacuum vessel. Considering a 27°C air temperature and a 35% relative humidity, the air dew point is 10°C and 4 kW is calculated to be the maximum heat load before condensation occurs. The heat load from the cryostat to the thermal shield is 10 kW (Table 2), which gives a temperature on the outer walls of the vessel lower than 10°C. The use of heaters is, therefore, necessary to avoid air condensation on it.

4. Model cryostat for larger scale thermal testing of Cryogel and glass spheres

For realistic thermal analyses of the insulating materials described, a new and more representative set-up was designed. The idea is to use a simple cryostat, roughly representing the actual one on a smaller scale. This would allow to benchmark the values of Cryogel thermal conductivity obtained before and to measure the ones of glass spheres. This set-up also allows examining the mechanical effect of compression by vacuum load on the insulating materials, in particular for the case of glass spheres. The cryogenic power is delivered by a Cryomech 420 pulse tube cooler providing 2.0 W at 4.2 K [9]. The set-up, shown in Figure 4, is composed of a stainless steel vacuum vessel, an aluminium thermal shield

and cold mass, and all free space is to be filled with insulating material. Expected are a 1.5 W heat load on the cold mass and a 50 W heat load on the thermal shield.

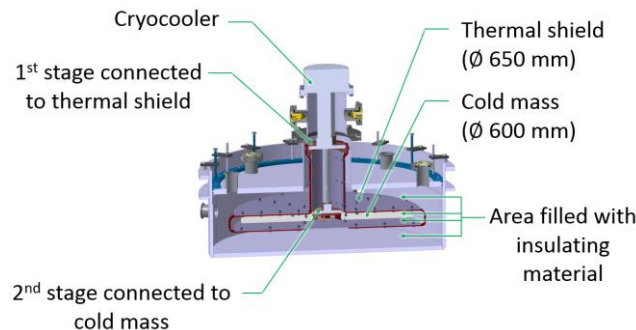

Figure 4. Set-up for thermal conductivity tests on Cryogel and glass spheres.

The thermal conductivity of the materials is measured for temperatures between 4 and 300 K and under vacuum. Therefore, the set-up is subjected to the atmospheric pressure of 1 bar, as for the actual cryostat. The test is repeated with 2 bar pressure as well. The different pressures are provided by bolts and two O-rings placed on the top plate of the vacuum vessel, which is therefore allowed to slide 100 mm down, in order to compress the insulating material. If the set-up is under compression, both thermal shield and cold mass need to be able to slide down. The stroke required is assured using copper braids as thermal links, providing thermal conduction between both cryocooler heads, thermal shield and cold mass. During the test of Cryogel, it is important, though, to avoid compression on the second stage head of the cryocooler. For this reason, an area of 100 mm diameter under the cryocooler's head will not be filled with Cryogel and the insulation here is assured by MLI placed around the Cryogel walls. The vacuum vessel further has four ports for allowing instrumentation cables, three optical windows and up to five ports for filling with glass spheres.

5. Conclusion

As part of the FCC study for next generation detector magnets, the option of using highly radiation transparent and light cryostats is being investigated. Insulating materials with acceptable mechanical properties, such as Cryogel Z and glass spheres under vacuum, are currently under investigation. A first test on Cryogel Z shows a thermal conductivity of 2.10×10^{-4} W/mK at 10 K under vacuum (pressure between 10^{-7} and 10^{-8} mbar). The values were used to conduct cryostat simulations, which show, for the FCC-ee⁺ case of a 2 T, 4 m bore, 6 m long solenoid, for a 250 mm thick cryostat wall, a total heat load of 390 W on the cold mass and 10 kW on the thermal shield. The new set-up for larger scale, more representative thermal conductivity tests on Cryogel and glass spheres was described. The upcoming tests will show, to a good approximation, whether the thermal and mechanical properties of the proposed insulating materials can satisfy the requirements imposed by the FCC project.

References

- [1] Mentink M *et al.* 2018 Evolution of the conceptual FCC-hh baseline detector magnet design *IEEE Trans. Appl. Supercond.* **28**
- [2] CMS Collaboration 1997 *CMS, The Magnet Project* (Geneva) pp 4-7
- [3] Yamamoto A *et al.* 2007 *The ATLAS central solenoid* 53-4
- [4] Silva H, Ilardi V, Kulenkampff T, Dudarev A and ten Kate H J 2018 Design of an ultra-thin, radiation length minimized, metallic cryostat for a 2 T/4 m free bore detector solenoid
- [5] Aspen Aerogels Cryogel Z technical specification sheet 2017
- [6] 3M K series glass spheres technical specification sheet 2009
- [7] Sumitomo RP-082B2 pulse tube cryocooler technical specification sheet
- [8] Agitec Cryogel Z technical specification sheet 2013
- [9] Cryomech PT420 technical specification sheet