

*Питання стабілізації якісних параметрів динамічних процесів вважаються добре вивченими. Традиційно для цього використовується техніка введення негативних зворотних зв'язків. Спутнім моментом використання техніки негативного зворотного зв'язку є необхідність дослідження стійкості динамічної системи в діапазоні допустимих управлінь, вибору критерію стабілізації і параметрів стабілізації.*

*На прикладах динамічних систем з безперервною і порціонною подачею технологічних продуктів показано, що введення негативного зворотного зв'язку не є єдиною альтернативою, що дозволяє стабілізувати якісні параметри вихідних продуктів.*

*Показано, що проблеми стабілізації динамічних систем пов'язані з тим, що сигнали управління передають у складі керуючих сигналів нелінійності технологічної частини системи. У зв'язку з цим виникають проблеми стійкості і якості стабілізації.*

*Запропоновано метод стабілізації, вільний від впливу параметрів технологічної частини та системно обгрунтовану ознаку класифікації системних об'єктів. З'являється можливість класифікувати, за цією ознакою, об'єкти системи щодо їх належності до технологічної підсистеми або підсистеми управління.*

*Також метод передбачає використання системно обгрунтованого принципу визначення оптимальних параметрів управління процесом стабілізації якісного параметру вихідного системного продукту з використанням верифікованого критерію ефективності використання ресурсів.*

*Реалізація запропонованого методу дозволяє створювати автоматичні динамічні системи, побудовані по єдиному архітектурному принципу*

*Ключові слова: зворотний зв'язок, стабілізація параметрів, синтез динамічної системи, вибір параметрів стабілізації*

UDC 007.5

DOI: 10.15587/1729-4061.2018.131296

# DEVELOPMENT OF STRUCTURE AND METHOD OF EFFECTIVE BINARY STABILIZATION OF QUALITY PARAMETER IN DYNAMIC SYSTEMS

I. Lutsenko

Doctor of Technical Sciences,  
ProfessorDepartment of Information and  
Control SystemsKremenchuk Mykhailo Ostrohradskyi  
National UniversityPershotravneva str., 20,  
Kremenchuk, Ukraine, 39600

E-mail: delo-do@i.ua

## 1. Introduction

In the functioning process, any production system solves two problems. The first one is making a product with required quality. The second is to maximize the resource efficiency during the solution of the first problem.

In dynamic systems, the efficiency improvement is tightly related to the issue of stabilization of quality parameters of the technological product. The stabilization process course means that the output product quality does not conform to the standard, and in such conditions the operational process optimization cannot have a positive result in principle.

There is the technique of negative feedback widely applied to solve the problem of stabilization of quality parameters of the output technological product in dynamic systems.

The negative feedback technique, which has been successfully implemented at the beginning of the 19th century [1], passed a long way of development [2, 3] and began to be used widely from 80 years of the last century [4, 5].

Popularization of use of the negative feedback idea was promoted by a number of publications that link this concept with basic cybernetics principles [6].

Problems of dynamic systems connected with the use of negative feedback were found soon. It is a possible loss

of stability and problems connected with the stabilization process efficiency [7].

Scientists have begun to change the structure and parameters of functional transformation to solve the problem of stability and dynamic systems efficiency increasing in the feedback loop. A functional converter had received the greatest popularity which includes proportional, integrating and differentiating links.

For historical reasons, the entire dynamic system with the feedback loop was determined by the concept of "automatic control system" (ACS) [8], and the functional converter – the PID controller.

Already the first wave of automation specialists has noted that "instability of the ACS is a scourge of automatic regulation, and time lag makes for instability" [9].

The indicator that allows expressing the judgment about the system stability was defined by the concept of "stability criterion". The Routh-Hurwitz stability criterion [10], the Popov criterion [11], and the Mikhailov-Nyquist criterion [12] became widely known.

As practice has shown, the use of classical and new developed stability criteria does not solve the stability problem in the general case.

At the same time, it was found that parameters such as overshoot and duration of the stabilization process adversely

affect the efficiency of the control process. This understanding led to an increase in the number of works related to the development of methods for improving the quality of regulation [13–16].

Despite the long history associated with the attempt to systematically solve the problem of estimating the parameters of the transition process, the selection of the quality criteria for the stabilization process is carried out on the basis of purely technical considerations. This is largely due to the fact that the term “extremum” is unreasonably associated with the concept of “optimum” [17, 18].

This means that the issues of stability and quality evaluation of transition processes of dynamic systems require the development of new approaches for the solution of these problem tasks.

The implementation of these approaches will increase the effectiveness of stabilization processes of dynamic systems quality parameters.

## 2. Literature review and problem statement

Numerous studies connected with the issues of the negative feedback use indirectly indicate the existence of conceptual problems.

Instead of centripetal tendencies, the questions related to the search of common assessment methods of stability and transition processes of dynamic systems continue to disintegrate into many separate directions. And each such direction requires the theory [19], deepening within the separate research [20] or the private solution [21].

Thus, in [22] it is noted that the problem of delay remained unsolved, in [23] a sufficient condition for stability with a final gain factor for a closed system is defined. In [24], a new approach to stability assessment and in [25] the tests for sustainability assessments are developed.

This means that the problem of sustainability has remained relevant for more than fifty years. At the same time, progress in this direction relates to the solution of individual problems and does not touch upon the foundations of general control principles.

Nevertheless, such attempts are periodically made and are aimed at the development of common methods of dynamic systems stability assessment. So, the concept D as stability [26], exponential stability [27], spectral stability [28] has been introduced, a new principle of stochastic systems stability has been defined in [29]. At the same time, the increase in the number of stability criteria did not lead to the achievement of such a qualitatively new level as the creation of general stability theory. The theory which would allow covering at least an extensive class of dynamic systems.

At the same time, in [30] it is noted that, despite a long story of researches devoted to the issue of stability, the systems with features on the stability threshold have received limited attention.

Yet the solution of the issues of transition processes optimization is still connected with the search of an extremum of such technical parameters as stabilization time [31], regulator response time [32], accuracy of positioning [33]. Traditionally, reregulation value is used as an optimization criterion [34].

At the same time, it is obvious that the known indicators of transition processes quality are not optimization criteria.

Their use is directed to the change of parameters which are directly not connected with the efficiency of the studied operations.

For example, the increase in accuracy is a limitation rather, than an extremum task. And the consequences of the value of overshoot or stabilization time of electric drive frequency will affect the energy consumption and the wear of technological mechanisms. Therefore, the stabilization of technological parameters should be carried out indirectly and comprehensively, based on the results of efficiency assessment of stabilization operations.

That is, the main issues of dynamic systems related to the definition of general principles of selection of transient process parameters require solution.

## 3. The aim and objectives of the study

The aim of the work is to develop the dynamic system structure that is free from the instability problem and the method of effective stabilization of the quality parameter for the uninterrupted technological process.

To achieve the aim, the following tasks were set:

- to identify the system problems of dynamic systems that are associated with the introduction of the negative feedback loop;
- to synthesize the universal structure of a stable dynamic system;
- to develop an effective method for estimating the parameters of the transient process of dynamic systems.

## 4. Analysis of features of improvement process of quality control in dynamic systems with negative feedback

Many studies related to the issues of sustainability and quality control indirectly indicate the presence of systemic problems in the concept associated with the feedback technique.

To define the possible reasons of problems in this question, we will consider the classical structure of the dynamic system with the PID controller (Fig. 1).

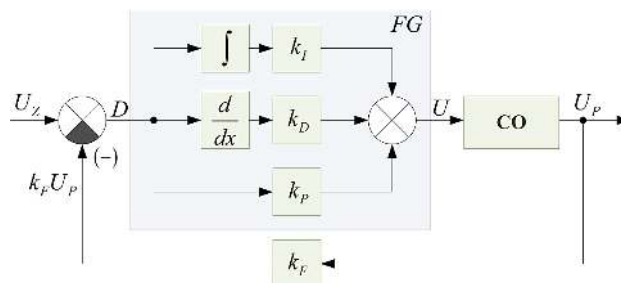

Fig. 1. Block diagram explaining the principle of negative feedback: CO – control object; FG – functional generator;  $U_z$  – stabilization parameter;  $D$  – error signal;  $U$  – control signal;  $U_p$  – stabilized parameter;  $k_I$  – integral part proportionality coefficient;  $k_D$  – differential part proportional part coefficient;  $k_P$  – proportionality coefficient;  $k_F$  – feedback coefficient

In such structure, the control signal  $U$  displays the features of the functional generator and the technology complex, which is defined as the control object.

$$U = f(D(k_{oc}U_p(U)))$$

In fact, the control object is a complex object.

Fig. 2 shows the block diagram which solves the problem of continuous liquid flow heating, taking into account stabilization of the temperature parameter.

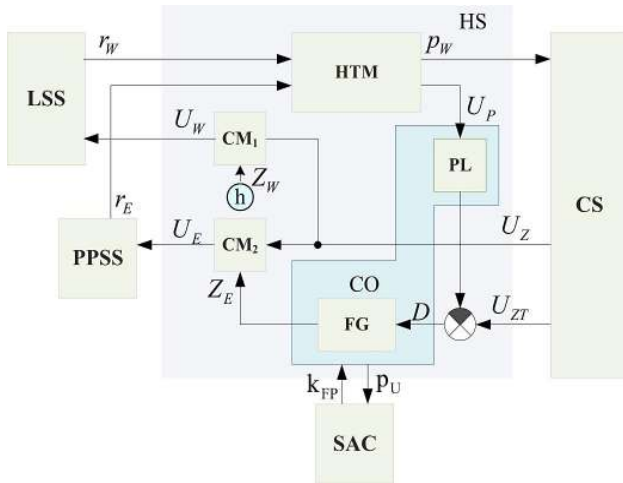

Fig. 2. Structure of the dynamic heating system with negative feedback: CS – consumption system; LSS – cold liquid supply system; PPSS – power product supply system; HS – heating system; CM<sub>1</sub>, CM<sub>2</sub> – coordination mechanisms; CO – control object; FG – functional generator; PL – proportional link; HTM – heating technology mechanism; r<sub>W</sub> – cold liquid flow; r<sub>E</sub> – power product flow; p<sub>W</sub> – heated liquid flow; U<sub>Z</sub> – heated liquid demand signal; U<sub>ZT</sub> – reference temperature signal; U<sub>P</sub> – current value of liquid temperature; k<sub>FP</sub> – vector of adjustable parameters; p<sub>U</sub> – control quality indicator; Z<sub>U</sub> – setting of liquid flow intensity; Z<sub>E</sub> – setting of energy product flow intensity; U<sub>W</sub> – liquid flow intensity control; U<sub>E</sub> – energy flow intensity control; D – output adder signal; h – manual data input

Such structure consists of several systems, each of which performs one basic technology function. These are the heated liquid consumption system (CS), the cold liquid supply system (LSS), the power product supply system (PPSS), the heating system (HS) and the automatic control system of the functional generator parameters (ACS).

Before the start of functioning, the consumption system assigns the task – the value of the stabilization parameter or the reference value of the heating temperature (U<sub>ZT</sub>) on the heating system input.

The active phase of the heating process starts at the time of high-level control pulse signal U<sub>Z</sub>. This signal comes to control inputs of coordination mechanisms MK<sub>1</sub> and MK<sub>2</sub>.

The mechanisms MK<sub>1</sub> and MK<sub>2</sub> are controllable keys, which transmit the reference signals Z<sub>W</sub> and Z<sub>E</sub> to the input of liquid and energy supply systems.

The feedback loop includes the functional generator, MK<sub>2</sub> coordination mechanism, power product supply technology mechanism, heating technology mechanism and technology products movement channels connecting them.

An additional impact is exerted by the parameters of the loop that includes the MK<sub>1</sub> coordination mechanism and the liquid supply system.

The task of the ACS is to select such coefficients of the dynamic system that, on the one hand, the system can't lose

stability, and on the other – it should provide the set quality of the transition process.

Time diagrams (Fig. 3) show the stabilization process of the temperature parameter in the system of continuous liquid heating when the coefficient of the integrating link in the feedback loop is changed.

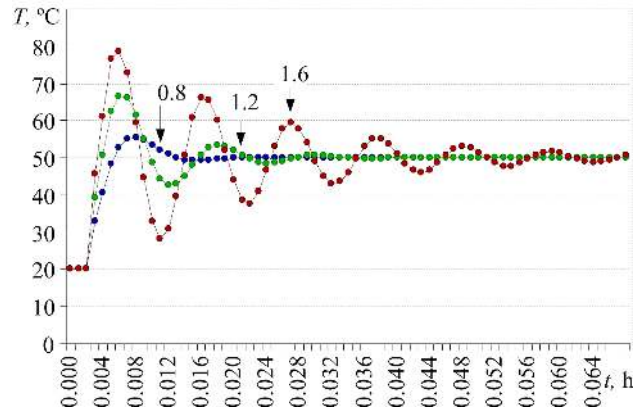

Fig. 3. Stabilization diagrams with different parameters of the integral link coefficient

In the ACS with high dynamics of transition processes, it is necessary to select up to four and more coefficients of the functional generator during regulation.

Thus, the structure of the functional generator and, therefore, the parameters number and regulation complexity, depends on the functional features of technology mechanisms and control mode.

### 5. Dynamic system structure synthesis with binary connections between subsystems

In order that the structure of dynamic systems did not change from the functional features of the technology part, it is necessary to define the new architectural principles of their creation.

Let us take as an axiom that the object of the dynamic system structure belongs to the technological subsystem in case if the input product of the object displays a functional connection with the input or output technological product. We will not consider the binary connection as a functional connection.

By binary connection we mean the connection of system objects using binary digital signals.

We will establish a binary connection between the technology subsystem and the control subsystem (Fig. 4).

In this form, the technology subsystem exchanges only binary messages with the control subsystem. These messages identify the position of the stabilized parameter relative to the reference value and its hit into the range of admissible values.

Let us see how the system works.

Signals at the input of the adder, rectifier and voltage comparators are functionally linked to the U<sub>P</sub> parameter, which it is necessary to stabilize. This means that these mechanisms relate to the technological subsystem.

A binary recording signal comes from the output of the voltage comparator KH<sub>1</sub>, which means that the value of the U<sub>P</sub> parameter is within the permissible temperature values or outside the permissible values.

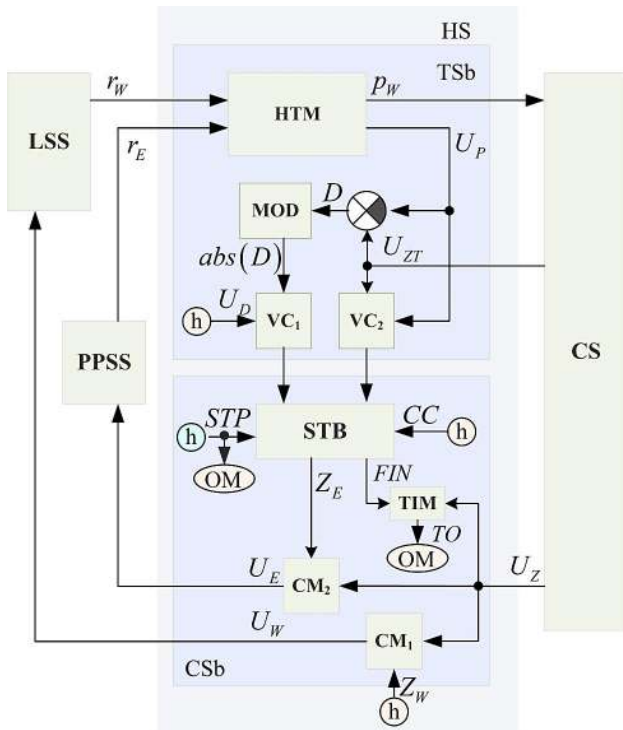

Fig. 4. Structure of the dynamic heating system with binary feedback: HS – heating system; TSb – technological subsystem; MOD – rectifier; VC<sub>1</sub>, VC<sub>2</sub> – voltage comparators; U<sub>D</sub> – allowable temperature deviation from the reference value; CSb – control subsystem; STB – stabilization module; D – temperature deviation from the reference value; STP – first step of stabilization; CC – coefficient of change of stabilization step; FIN – signal of temperature hit into the range of admissible values; TIM – timer; OM – optimization module; TO – operation time of heating temperature stabilization

At the output of the KH<sub>2</sub> comparator, a binary signal is generated, which indicates the position of the monitored parameter current value according to the reference signal.

Output signals of the comparators come to the stabilization module (STB) of the control subsystem (CSb). Also, the first step task signal of the stabilization signal (STP) and the coefficient of control step change (KM) arrive at the input of this module.

The initial signal value of STP is given on the basis of subjective representations. The search for a reasonable value of the initial step of control change is the optimization object.

The KM coefficient value is intended to change the STP step value. Within this research, the KM value was established at the level of two units and further did not change.

The heating operation and, accordingly, the stabilization operation, begins at the U<sub>Z</sub> signal time. This timepoint corresponds to the start of the stabilization operation (t<sub>s</sub>). At this timepoint, the task signal of the power product supply Z<sub>E</sub> is equal to zero.

After the sampling step time (dt) expires, the control value increases by the value of the initial step Z<sub>E\_NEW</sub> = Z<sub>E\_OL</sub> + STP. At the same time, the low-level signal is set at the output of KH<sub>2</sub>, since U<sub>P</sub> < U<sub>ZT</sub>.

Here Z<sub>E\_OL</sub> is the task value at the previous sampling interval step, Z<sub>E\_NEW</sub> is the task value at the current sampling interval step.

If the U<sub>P</sub> value exceeds the U<sub>ZT</sub> level, the step value is halved, and the step sign changes to the opposite. In this case, the new value of the reference signal Z<sub>E\_NEW</sub> is determined from the expression Z<sub>E\_NEW</sub> = Z<sub>E\_OL</sub> - STP/KM. Change of the sign and division of the current STP value by KM happens every time when the value of the U<sub>P</sub>(t) function crosses the value of the U<sub>ZT</sub>(t) function.

When the U<sub>P</sub> parameter value falls within the area of U<sub>D</sub> ± abs(D) values, the STB module gives a high-level pulse signal FIN.

Due to inertia and process delays in the technology channels, the parameter U<sub>P</sub>, after hit to the area of admissible values, can leave this area again. The search stabilization process continues until the FIN signal turns into a continuous series of high-level pulse signals.

At this time moment, defined as t<sub>F</sub>, the stabilization operation of the U<sub>P</sub> parameter comes to end. The timer TP defines the stabilization operation time TO = t<sub>F</sub> - t<sub>s</sub> and gives it to the input of the optimization module (OM).

The time diagrams explaining the principle of stabilization of the temperature parameter are presented in Fig. 5.

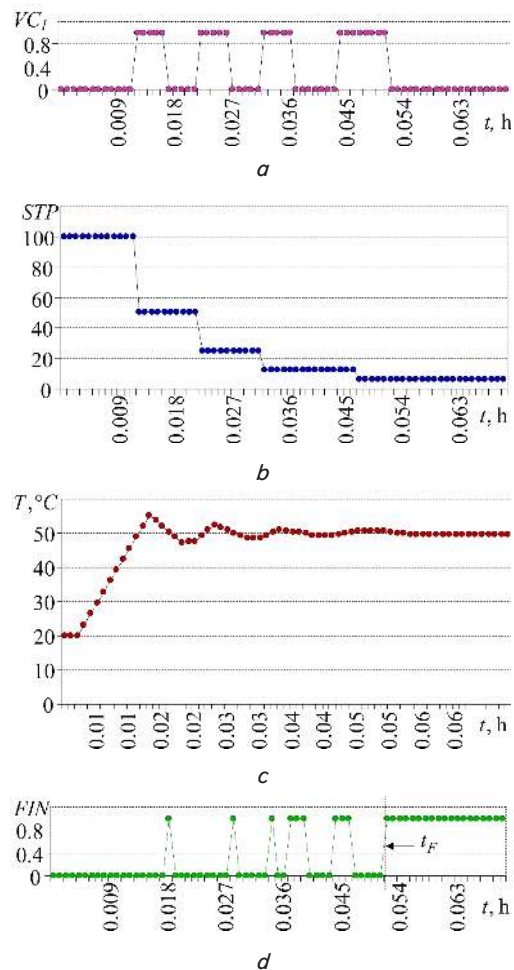

Fig. 5. Time diagrams of the dynamic system with binary feedback: a – position of the stabilized parameter relative to the reference value; b – change step of stabilization control; c – liquid current temperature; d – registration of temperature hit in the range of permissible values

Due to the binary outcome, the functional features of the technological part do not affect the principles of stabiliza-

zation of the control subsystem. In this case, it is universal for the class of dynamic systems with a continuous supply of action directional products (ADP).

For the class of dynamic systems with a batch supply of ADP, the stabilization module also does not change. The changes concern the structure of the technological subsystem.

Fig. 6 shows the block diagram of the starting process stabilization of the movement system. As the movement mechanism, the direct current motor is used [35].

For the solution of the speed stabilization problem, the control mechanism of ADP supply and determination of the completion moment of its supply is integrated into the technology subsystem structure. This function is performed by the mechanism of allocation of the back front of the signal (ZF) [36].

The signal of completion of the ADP supply is given on the controlled input MC<sub>2</sub>. As a result, the signal for the power product supply begins to arrive after the completion of the ADP supply.

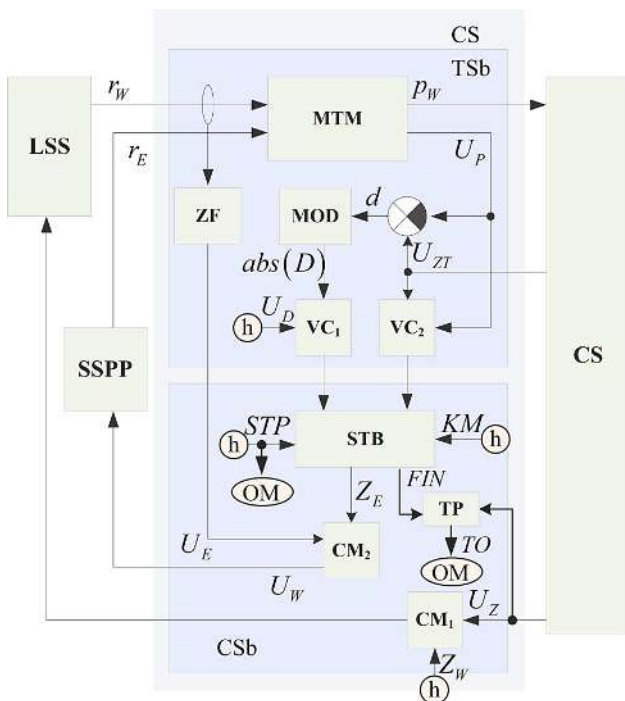

Fig. 6. Structure of the dynamic movement system with binary feedback: PFS – product feed system; MTM – movement technology mechanism; ZF – allocation mechanism of the signal back front

Fig. 7 shows the time diagram of the movement mechanism speed stabilization with binary feedback.

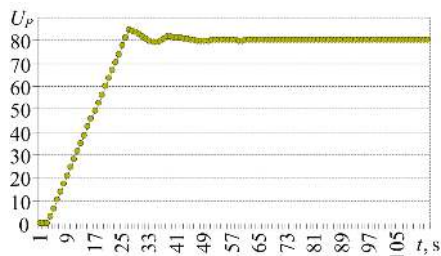

Fig. 7. Time diagram of speed stabilization of the movement mechanism with binary feedback

As can be seen, the dynamic system structure with ADP batch feed differs slightly from the structure of the dynamic system with ADP continuous feed. In this case, the stabilization principle remains unchanged.

### 6. Optimization of dynamic system stabilization process

Negative consequences of dynamic system instability are due to the fact that the quality of its output is unsatisfactory. For example, the temperature of the fluid is beyond the limits of allowed values. In this case, the heating costs and the cost of substandard liquid relate to the stabilization operation losses.

The size of losses and duration of the stabilization process are the factors that reduce the efficiency of the operational process in general.

In general, the damage from the unstable parameter of the output product of the dynamic system depends on the estimate of the stabilization process costs, stabilization process time, and output product cost.

Depending on the initial step size and the law of task change, the effectiveness of the stabilization operation varies.

In the case of liquid heating during the stabilization operation, cold liquid (generally ADP) and the power product (PP) are spent.

Knowing the cost of these products, as well as the cost estimate of the heated liquid unit, the efficiency of the stabilization operation can be determined.

Fig. 8 shows the block diagram of the efficiency determination module of the stabilization operation [37].

Evaluation indicator [38] was used to determine the efficiency index, which underwent the verification procedure for the possibility of its use as an efficiency criterion [39–43]:

$$E = \frac{(PE - RE)^2 TA^2}{RE \cdot PE \cdot TO^2} \tag{1}$$

Here TA is the unit time interval for determining the absolute potential effect of the stabilization operation [38].

The stabilization operation by optimizing the initial parameters is carried out if the stabilization result is valued above the technological start-up losses. In this case, PE > RE.

Thus, to evaluate the process efficiency, the PE value must exceed the RE maximum value.

$$PE > \max(RE_i),$$

where *i* is the *i*-th launch operation startup cost identifier

For definiteness, it is assumed that the PE value is 10 % higher than the maximum RE value.

Using the expression (1), it is possible to define the efficiency of the stabilization operation and to choose such initial step of stabilization at which the stabilization operation is most effective.

For the liquid heating operation, the dependence of resource efficiency on the value of the initial step of stabilization; is represented on the chart (Fig. 9).

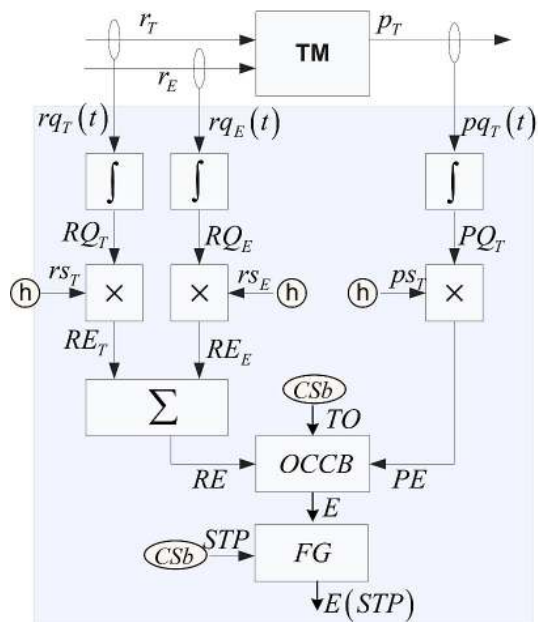

Fig. 8. Block diagram for determining the dependence of the efficiency index on the initial step of stabilization:

TM – technological mechanism; OCCB – optimization criterion calculating block;  $r_T$  – input technological product;  $r_E$  – energy product;  $p_T$  – output technological product;  $rq_T$  – registration signal of the input technological product quantitative parameter;  $rq_E$  – registration signal of the energy product quantitative parameter;  $pq_T$  – registration signal of the output technological product quantitative parameter;  $RQ_T$  – input process product integral value;  $RQ_E$  – energy product integral value;  $PQ_T$  – input technological product integral value;  $rs_T$  – input technological product unit cost;  $rs_E$  – energy product unit cost;  $ps_T$  – output technological product unit cost;  $RE_T$  – input technological product cost;  $RE_E$  – energy product cost;  $RE$  – input products cost;  $TO$  – stabilization operation time;  $PE$  – input products cost;  $E$  – efficiency index

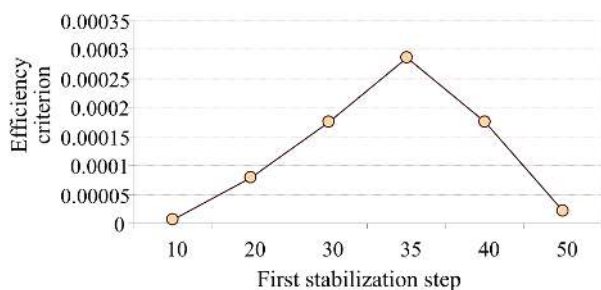

Fig. 9. Resource efficiency depending on the value of the initial stabilization step

The optimum value of the initial stabilization step is 35 units.

### 7. Determination of effective stabilization method of dynamic system technology parameter

The conducted research allows formalizing the determination procedure of the optimum value for setting the

stabilization process initial step in the form of stabilization method.

The method's idea is to perform the following procedure:

1. To set the reference value of stabilization parameter ( $U_{zt}$ ) and the range of allowable deviation from the reference value ( $U_D$ ).
2. To define the minimum value of the initial stabilization step (STP) and the initial stabilization control value ( $Z_E$ ).
3. To determine the time sampling step ( $dt$ ).
4. To form a new control signal of the stabilization process ( $Z_{E\_NEW}$ ) by changing the value of old control ( $Z_{E\_OLD}$ ) on each step of time sampling by the size of the initial stabilization step (STP)  $Z_{E\_NEW} = Z_{E\_OLD} + STP$ .
5. To determine the position of the technology parameter signal ( $U_P$ ) relative to the reference stabilization value ( $U_{ZT}$ ) and to remain in the form of the position marker (M).  
If  $U_P \leq U_{ZT}$ ,  $M = 1$  otherwise  $M = -1$ .
6. To determine and store the sign of the error between the value of stabilized parameter and the reference stabilization value in the form of the saved parameter ( $M_{OLD}$ ), in the previous step.
7. When the signs of the parameters M and  $M_{OLD}$  are different, the value of the new step  $STP_{NEW}$  and the sign of the step change with respect to the old value  $STP_{OLD}$ .

$$STP_{NEW} = STP_{OLD}, \text{ if } M_{OLD} = 1, M = 1;$$

$$STP_{NEW} = -(STP_{OLD}/KM), \text{ if } M_{OLD} = 1, M = -1;$$

$$STP_{NEW} = -STP_{OLD}, \text{ if } M_{OLD} = -1, M = -1;$$

$$STP_{NEW} = STP_{OLD}/KM, \text{ if } M_{OLD} = -1, M = 1.$$

8. To control the hit moment of the stabilization parameter to the area of admissible values

$$\text{If } U_P \leq U_{ZT} \pm abs(D), FIN = 1, \text{ otherwise } FIN = 0.$$

9. To define the stabilization process completion moment. The time point after which the stabilization parameter N does not leave the range of admissible values is determined by stabilization completion (the value of N is found experimentally).

10. To define the cost estimate of the stabilization process (RE), the time of the stabilization process (TO), and the cost estimate of the stabilization result (PE)

$$RE = \sum_{i=1}^I \left( rs_i \int_{t_s}^{t_f} rq_i(t) dt \right);$$

$$PE = \sum_{j=1}^J \left( ps_j \int_{t_s}^{t_f} pq_j(t) dt \right);$$

$$TO = t_s - t_f,$$

Where  $I$  is the number of input technology operation products;  $J$  is the number of output operation products (for example, the main and co-product).

11. To define the efficiency of the stabilization operation ( $E$ ) from the expression (1).

12. To define such initial stabilization step (STP) at which the stabilization operation is most effective in the course of optimization.

## 8. Discussion of research results concerning the synthesis of dynamic systems

It often turns out that the proposed solution of the practical problem begins to be perceived as a general pattern.

The idea that negative feedback is the general principle of control got on the fertile soil paved by cybernetics advertizing. The intensive research has begun connected with the search for a general approach to the solution of stability problem and stabilization quality criterion.

Since almost each object getting to the feedback chain has the individual nonlinearity, the number of works related to the search for common solutions increases exponentially. Such growth of the number of papers in this direction has created a cumulative advertizing effect the results of which can be observed today.

The conducted research showed that the functional separation of the technological part and the control part allows synthesizing a single structure of the dynamic system and creating a method of stabilization of quality parameters that are free from the functional features of the technological part.

It is found that the introduction of negative feedback is not the only way to solve the stabilization problem.

Taking into account the results of the conducted studies, it can be suggested that the presence of negative feedback, as a common cybernetic feature of dynamic systems, can be questioned.

The proposed method of binary stabilization successfully solves the problem of stabilizing the technological parameter of the dynamic system. In this case, the features of the technological part are not imposed on the control process.

In the case if several quality parameters dynamically change during the control process, the number of stabilization modules increases proportionally.

The paper considers the optimization of the initial control step. Obviously, the efficiency of the optimization process will also be affected by the change in the CM parameter or the use of methods of technical forecasting for an adaptive change in the control step while it approaches the reference value. Further research is needed in these areas.

## 9. Conclusions

1. The system problem of negative feedback loop use in dynamic automatic control systems is defined. The essence of the problem is due to the presence of a functional connection between the processes of the technological subsystem and the control subsystem. The formal sign of the system objects functional belonging to the technological subsystem or control subsystem is defined. According to this feature, the object belongs to the technological subsystem if its input signal is functionally connected with the parameter of the input or output technological product. The object belongs to the control subsystem if there is no such functional dependence, and there is only a binary connection with the technological subsystem. The proposed classification principle opens the possibility of synthesizing stable dynamic systems that are built with the use of the general principles of stabilizing the parameters of output technological products.

2. The structure included in the technology subsystem, which provides the function of stabilization of the technology parameter of the output product and uses binary connection with the control subsystem is synthesized. The structure of the module consists of objects, each of which performs one simple function. The module input products are the stabilized technology parameter, the reference stabilization value and the value of permissible deviation from the reference value. The output products of the module are the binary signal of technology parameter position relative to the reference signal and a binary signal of hit of the technology parameter to the area of admissible values. Such approach provides an opportunity of eliminating the instability mode and tough level of stabilization of the controlled technology parameter.

3. The binary stabilization method of the technological parameter of the output product is developed. The proposed method provides an opportunity to implement a unified approach to the selection of optimal parameters of the stabilization process by the criterion of resource efficiency.

## References

1. Ang K. H., Chong G., Li Y. PID control system analysis, design, and technology // IEEE Transactions on Control Systems Technology. 2005. Vol. 13, Issue 4. P. 559–576. doi: 10.1109/tcst.2005.847331
2. Ziegler J. G., Nichols N. B. Optimum settings for automatic controllers // Trans. ASME. 1942. Vol. 64. P. 759–768.
3. Chien K. L., Hrons J. A., Reswick J. B. On the Automatic Control of Generalized Passive Systems // Transactions of the American Society of Mechanical Engineering. 1972. Vol. 74. P. 175–185.
4. O'Dwyer A. PID compensation of time delayed processes 1998–2002: a survey // Proceedings of the 2003 American Control Conference, 2003. 2003. doi: 10.1109/acc.2003.1239802
5. Åström K. J., Hägglund T. The Future of PID Control // IFAC Proceedings Volumes. 2000. Vol. 33, Issue 4. P. 19–30. doi: 10.1016/S1474-6670(17)38216-2
6. Viner N. Kibernetika ili upravlenie i svyaz' v zhitvotnom i mashine. Moscow: Nauka, 1983. 344 p.
7. Stability of adaptive systems: passivity and averaging analysis / Anderson B. D., Bitmead R. R., Johnson C. R. et. al. MIT Press, 1987. 300 p.
8. Petrovas A., Rinkevičienė R. Automatic Control Theory I, II: A Laboratory Manual // Technika. 2012. 98 p. doi: 10.3846/1335-s
9. Avtomaticheskij kontrol' i regulirovanie tekhnologicheskikh processov na zhelezorudnyh fabrikah / Goncharov Yu. G., Davidkovich A. S. et. al. Moscow: Nedra, 1968. 227 p.
10. Hammond P. H. Feedback theory and its applications. London: English Universities Press, 1958. 348 p.
11. Spravochnik po teorii avtomaticheskogo upravleniya / A. A. Krasovskiy (Ed.). Moscow: Nauka, 1987. 712 p.
12. Horowitz M. Synthesis of feedback systems. Academic Press, 1963. 740 p. doi: 10.1016/c2013-0-12529-9
13. Shen J. C., Chiang H. K. PID tuning rules for second order systems // 5th Asian Control Conference. 2004. P. 472–477.

14. Silva G. J., Datta A., Bhattacharyya S. P. New results on the synthesis of PID controllers // *IEEE Transactions on Automatic Control*. 2002. Vol. 47, Issue 2. P. 241–252. doi: 10.1109/9.983352
15. A Method for Improving the Robustness of PID Control / Skoczowski S., Domek S., Pietruszewicz K., Broel-Plater B. // *IEEE Transactions on Industrial Electronics*. 2005. Vol. 52, Issue 6. P. 1669–1676. doi: 10.1109/tie.2005.858705
16. Karimi A., Garcia D., Longchamp R. PID controller tuning using Bode's integrals // *IEEE Transactions on Control Systems Technology*. 2003. Vol. 11, Issue 6. P. 812–821. doi: 10.1109/tcst.2003.815541
17. Hemery E. E. PC-based packages for identification, optimization, and adaptive control // *IEEE Control Systems*. 1991. Vol. 11, Issue 2. P. 37–43. doi: 10.1109/37.67674
18. Adaptive H/sub 2/ optimal control based on Smith predictor for continuous time systems with unknown time delay / Ren X. M., Rad A. B., Lo W. L., Chan P. T. // *International Conference on Control and Automation*. 2005. doi: 10.1109/icca.2005.1528109
19. Country M. Advancing the pH hypothesis of negative feedback to photoreceptors: sources of protons and a role for bicarbonate in feedback // *The Journal of Physiology*. 2017. Vol. 595, Issue 4. P. 1023–1024. doi: 10.1113/jp273518
20. Lanzon A., Chen H.-J. Feedback Stability of Negative Imaginary Systems // *IEEE Transactions on Automatic Control*. 2017. Vol. 62, Issue 11. P. 5620–5633. doi: 10.1109/tac.2017.2688579
21. Control-Quality Driven Design of Embedded Control Systems with Stability Guarantees / Aminifar A., Eles P., Peng Z., Cervin A., Arzen K.-E. // *IEEE Design & Test*. 2017. P. 1–1. doi: 10.1109/mdat.2017.2766564
22. Gu K., Naghnaei M. Stability Crossing Set for Systems With Three Delays // *IEEE Transactions on Automatic Control*. 2011. Vol. 56, Issue 1. P. 11–26. doi: 10.1109/tac.2010.2050162
23. Novara C., Formentin S. Data-Driven Inversion-Based Control of Nonlinear Systems With Guaranteed Closed-Loop Stability // *IEEE Transactions on Automatic Control*. 2018. Vol. 63, Issue 4. P. 1147–1154. doi: 10.1109/tac.2017.2744499
24. Dedesh V. T. Stability and self-oscillations of nonlinear single-circuit automatic control systems // *TsAGI Science Journal*. 2010. Vol. 41, Issue 3. P. 341–356. doi: 10.1615/tsagisij.v41.i3.70
25. Lazar M., Heemels W. P. M. H., Teel A. R. Further Input-to-State Stability Subtleties for Discrete-Time Systems // *IEEE Transactions on Automatic Control*. 2013. Vol. 58, Issue 6. P. 1609–1613. doi: 10.1109/tac.2012.2231611
26. Bokharaie V. S., Mason O., Verwoerd M. D-Stability and Delay-Independent Stability of Homogeneous Cooperative Systems // *IEEE Transactions on Automatic Control*. 2010. Vol. 55, Issue 12. P. 2882–2885. doi: 10.1109/tac.2010.2076334
27. Costa E. F., do Val J. B. R. Uniform Approximation of Infinite Horizon Control Problems for Nonlinear Systems and Stability of the Approximating Controls // *IEEE Transactions on Automatic Control*. 2009. Vol. 54, Issue 4. P. 881–886. doi: 10.1109/tac.2008.2010970
28. Bulatovic R. M. A stability criterion for circulatory systems // *Acta Mechanica*. 2017. Vol. 228, Issue 7. P. 2713–2718. doi: 10.1007/s00707-017-1841-4
29. Zhao X., Deng F. A New Type of Stability Theorem for Stochastic Systems With Application to Stochastic Stabilization // *IEEE Transactions on Automatic Control*. 2016. Vol. 61, Issue 1. P. 240–245. doi: 10.1109/tac.2015.2438414
30. Knorn S., Middleton R. H. Stability of Two-Dimensional Linear Systems With Singularities on the Stability Boundary Using LMIs // *IEEE Transactions on Automatic Control*. 2013. Vol. 58, Issue 10. P. 2579–2590. doi: 10.1109/tac.2013.2264852
31. Amanullah M., Tiwari P. Optimization of PID Parameter In Control System Tuning With Multi-Objective Genetic Algorithm // *Journal of Engineering Research and Applications*. 2014. Vol. 4, Issue 5. P. 60–66.
32. Mahdi S. A. Optimization of PID Controller Parameters based on Genetic Algorithm for non-linear Electromechanical Actuator // *International Journal of Computer Applications*. 2014. Vol. 94, Issue 3. P. 11–20. doi: 10.5120/16322-5573
33. PID-Controller Tuning Optimization with Genetic Algorithms in Servo Systems / Jaen-Cuellar A. Y., de J. Romero-Troncoso R., Morales-Velazquez L., Osornio-Rios R. A. // *International Journal of Advanced Robotic Systems*. 2013. Vol. 10, Issue 9. P. 324. doi: 10.5772/56697
34. Optimization of PID Controller Parameters on Flow Rate Control System Using Multiple Effect Evaporator Particle Swarm Optimization / Dwi Argo B., Hendrawan Y., Firmanda Al Riza D., Jaya Laksono A. N. // *International Journal on Advanced Science, Engineering and Information Technology*. 2015. Vol. 5, Issue 2. P. 62. doi: 10.18517/ijaseit.5.2.491
35. Development of the method for determining optimal parameters of the process of displacement of technological objects / Lutsenko I., Tytiuk V., Oksanych I., Rozhnenko Z. // *Eastern-European Journal of Enterprise Technologies*. 2017. Vol. 6, Issue 3 (90). P. 41–48. doi: 10.15587/1729-4061.2017.116788
36. Lutsenko I., Fomovskaya E., Serduik O. Development of executive system architecture of the converting class // *Eastern-European Journal of Enterprise Technologies*. 2016. Vol. 4, Issue 2 (82). P. 50–58. doi: 10.15587/1729-4061.2016.74873
37. Lutsenko I., Fomovskaya E. Identification of target system operations. The practice of determining the optimal control // *Eastern-European Journal of Enterprise Technologies*. 2015. Vol. 6, Issue 2 (78). P. 30–36. doi: 10.15587/1729-4061.2015.54432
38. Development of the method of quasi-optimal robust control for periodic operational processes / Lutsenko I., Fomovskaya E., Koval S., Serduik O. // *Eastern-European Journal of Enterprise Technologies*. 2017. Vol. 4, Issue 2 (88). P. 52–60. doi: 10.15587/1729-4061.2017.107542
39. Development of the method for testing of efficiency criterion of models of simple target operations / Lutsenko I., Vihrova E., Fomovskaya E., Serduik O. // *Eastern-European Journal of Enterprise Technologies*. 2016. Vol. 2, Issue 4 (80). P. 42–50. doi: 10.15587/1729-4061.2016.66307



40. Formal signs determination of efficiency assessment indicators for the operation with the distributed parameters / Lutsenko I., Fomovskaya E., Oksanych I., Vikhrova E., Serdiuk O. // Eastern-European Journal of Enterprise Technologies. 2017. Vol. 1, Issue 4 (85). P. 24–30. doi: 10.15587/1729-4061.2017.91025
41. Development of a verification method of estimated indicators for their use as an optimization criterion / Lutsenko I., Fomovskaya E., Oksanych I., Koval S., Serdiuk O. // Eastern-European Journal of Enterprise Technologies. 2017. Vol. 2, Issue 4 (86). P. 17–23. doi: 10.15587/1729-4061.2017.95914
42. Development of test operations in different duration to increase verification quality of efficiency formula / Lutsenko I., Fomovskaya E., Vihrova E., Serdiuk O., Fomovsky F. // Eastern-European Journal of Enterprise Technologies. 2018. Vol. 1, Issue 4 (91). P. 42–49. doi: 10.15587/1729-4061.2018.121810
43. Development of the method of modeling operational processes for tasks relating to decision-making / Lutsenko I., Oksanych I., Shevchenko I., Karabut N. // Eastern-European Journal of Enterprise Technologies. 2018. Vol. 2, Issue 4 (92). P. 26–32. doi: 10.15587/1729-4061.2018.126446

*При використанні багатьох сучасних методів автоматичної генерації дискретних моделей поверхонь неявно заданих геометричних об'єктів втрачається точність апроксимації в околах особливостей (отворів, зламів тощо). Для покращення дискретних моделей геометричних об'єктів використовують різні методи згладжування. Існуючі методи згладжування проблеми спрямовані на трикутні елементи, але менш дослідженою є оптимізація дискретних моделей поверхонь геометричних об'єктів на базі елементів іншої форми (наприклад, чотирикутників).*

*Запропоновано математичний апарат, заснований на використанні енергетичного функціоналу для кожного вузла моделі. Запропонований функціонал враховує відстань від поточного вузла до суміжних і дистанцію від геометричних центрів інцидентних елементів до поверхні.*

*Розроблено алгоритм мінімізації енергетичного функціоналу при згладжуванні дискретних моделей поверхонь неявно заданих геометричних об'єктів. Розроблений алгоритм є модифікацією метода Гауса на випадок пошуку мінімуму в локальних координатах багатокутника, утвореного сусідніми елементами. Алгоритм є локальним: мінімізація виконується послідовно для кожного вузла моделі, тому багатократно його застосування дозволяє отримати моделі з більш точною апроксимацією поверхні.*

*Розроблений алгоритм мінімізації функціоналу не потребує додавання нових вузлів. Як наслідок, можливо використовуючи єдину процедуру оптимізувати дискретні моделі поверхонь на базі трикутників, чотирикутників або мішаного типу (що містять трикутники і чотирикутники одночасно). У результаті підвищується точність апроксимації поверхонь в околах особливостей, що показано на прикладах згладжування моделей складних об'єктів*

*Ключові слова: геометричний об'єкт, дискретна модель, неявна функція, згладжування, поверхня, енергетичний функціонал*

UDC 519.6: 004.942

DOI: 10.15587/1729-4061.2018.130787

# OPTIMIZED SMOOTHING OF DISCRETE MODELS OF THE IMPLICITLY DEFINED GEOMETRICAL OBJECTS' SURFACES

**S. Choporov**

PhD, Associate Professor\*

E-mail: s.choporoff@znu.edu.ua

**S. Homeniuk**

Doctor of Technical Sciences, Professor\*

E-mail: serega@znu.edu.ua

**S. Grebenyuk**

Doctor of Technical Sciences, Associate

Professor, Head of Department\*\*

E-mail: gsm1212@ukr.net

\*Department of Software Engineering\*\*\*

\*\*Department of

Fundamental Mathematics\*\*\*

\*\*\*Zaporizhzhia National University

Zhukovskoho str., 66,

Zaporizhzhia, Ukraine, 69600

## 1. Introduction

Modeling of many natural and technical objects is associated with the need to describe their shape in the form of mathematical relations. A very common way of determining the set of points belonging to some object is to use implicit mathematical functions.

It is assumed that a set of points  $\Omega$  is defined implicitly if a logical predicate  $S(P)$  such that  $\Omega = \{P: S(P) = \text{true}\}$  is defined for each point  $P = (x, y, z)$ . The simplest form of such a predicate is the restriction to the sign of some real function in the form of the inequality  $F(P) \geq 0$ . For example, the function sphere  $(x, y, z) = r^2 - x^2 - y^2 - z^2$  is greater than zero at the points of the domain limited by a sphere of radius  $r$  centered