

Diesel Combustion and Emission Using High Boost and High Injection Pressure in a Single Cylinder Engine*

(Effects of Boost Pressure and Timing Retardation on Thermal Efficiency and Exhaust Emissions)

Yuzo AOYAGI**, Eiji KUNISHIMA**, Yasuo ASAUMI**, Yoshiaki AIHARA**,
Matsuo ODAKA*** and Yuichi GOTO***

Heavy-duty diesel engines have adopted numerous technologies for clean emissions and low fuel consumption. Some are direct fuel injection combined with high injection pressure and adequate in-cylinder air motion, turbo-intercooler systems, and strong steel pistons. Using these technologies, diesel engines have achieved an extremely low CO₂ emission as a prime mover. However, heavy-duty diesel engines with even lower NO_x and PM emission levels are anticipated. This study achieved high-boost and lean diesel combustion using a single cylinder engine that provides good engine performance and clean exhaust emission. The experiment was done under conditions of intake air quantity up to five times that of a naturally aspirated (NA) engine and 200 MPa injection pressure. The adopted pressure booster is an external supercharger that can control intake air temperature. In this engine, the maximum cylinder pressure was increased and new technologies were adopted, including a monotherm piston for endurance of $P_{\max} = 30$ MPa. Moreover, every engine part is newly designed. As the boost pressure increases, the rate of heat release resembles the injection rate and becomes sharper. The combustion and brake thermal efficiency are improved. This high boost and lean diesel combustion creates little smoke; ISCO and ISTHC without the ISNO_x increase. It also yields good thermal efficiency.

Key Words: Power Unit, Engine Combustion, Diesel Engine / High Boost, High Pressure Injection, Common Rail Injector, Emission

1. Introduction

Heavy-duty diesel engines have undergone continuous improvement in fuel consumption and exhaust emissions through change from a pre-chamber type to a direct-injection type, combustion modification using high-pressure injection and swirl air motion⁽¹⁾, adoption of turbo-intercoolers^{(2),(3)}, and alteration of piston materials from aluminum to iron⁽⁴⁾. Those improvements have earned a worldwide reputation for diesel engines as the prime movers of low CO₂ emission⁽⁵⁾. However, reduction of exhaust emissions such as NO_x and PM is required

urgently⁽⁶⁾.

Improvement of exhaust emissions is now proceeding by adoption of a newly developed common rail fuel injection system that makes high-pressure injection possible and a turbo charging system that provides air to the cylinder in large amounts. Further improvement will be carried out in this manner in the future⁽⁷⁾⁻⁽¹¹⁾. A catalyst is indispensable for reduction of exhaust emissions from diesel engines, but it is necessary to minimize exhaust emissions. In addition, it is important use after-treatment efficiently. This study measured the engine performance and exhaust emissions, under the condition that the fuel injection pressure was raised to 200 MPa using single cylinder engines. The intake air amount was raised to five times that of NA engine using high boost pressure.

Nomenclature

BMEP : Brake mean effective pressure kPa, MPa

* Received 1st February, 2005 (No. 05-4012)

** New ACE Institute Co., Ltd., 2530 Karima, Tsukuba-shi, Ibaraki 305-0822, Japan. E-mail: aoyagi@nace.jp

*** National Traffic Safety and Environment Laboratory, 7-42-27 Jindaiji-higashi-machi, Chofu-city, Tokyo 182-0012, Japan

Table 1 Engine specifications and test conditions

Item	Specifications
Engine type	DI single cylinder
Bore and stroke	135 × 140 mm
Displacement	2004 cm ³
Cylinder head	4 valve
Comb. chamber	D = 98 mm, shallow dish
Compression ratio	15
Swirl ratio	0.6
Air charging	External super charger with cooler, Max 501.3 kPa
Injection system	Accumulator type
Injector	Hole nozzle, 0.17 × 6
Injection pressure	200 MPa
Engine speed	1000 - 2000 rpm
Fuel	Diesel fuel JIS No.2 (Sulfur 400 ppm)

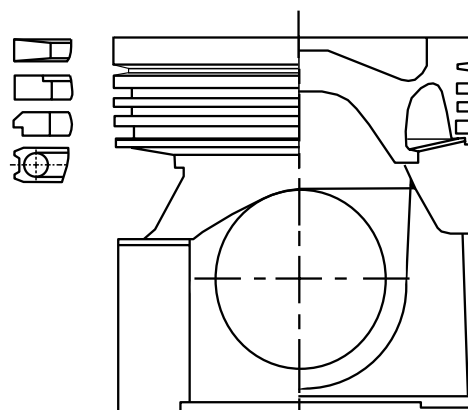
Fig. 1 Combustion chamber shape and monotherm steel piston for $P_{\max} = 30$ MPa

IMEP : Indicated mean effective pressure kPa, MPa

Ne : Engine speed rpm

Pb : Boost pressure kPa

Pinj : Injection pressure MPa

q : Injection fuel quantity mm³/st

ROHR : Rate of heat release kJ/°CA

ISNOx : Indicated specific NOx g/kWh

ISCO : Indicated specific CO g/kWh

ISTHC : Indicated specific THC g/kWh

SMOKE : Smoke FSN

ε : Compression ratio

λ : Air excess ratio

η_e : Brake thermal efficiency %

η_i : Indicated thermal efficiency %

2. Experimental Condition

2.1 Experimental single cylinder engine

Table 1 shows specifications of the engine used herein. This single cylinder engine was designed to allow it to withstand a maximum cylinder pressure of $P_{\max} = 30$ MPa. The piston used in this experiment is a monotherm piston made of steel, which can withstand $P_{\max} = 30$ MPa. The shapes of the cross sections of the piston and the combustion chamber are shown in Fig. 1. Most engine parts such as the piston pin, conrod, crank shaft, metal materials, intake and exhaust valves, cylinder head, head bolt, head gasket, cylinder block, as well as the piston, were designed to withstand $P_{\max} = 30$ MPa.

In the high boost experiment, it was considered that P_{\max} would rise higher than 30 MPa. The compression ratio $\varepsilon = 15.0$ was chosen to reduce the P_{\max} . The regular compression ratio was $\varepsilon = 16.5$.

The fuel injection pressure at the performance test was 200 MPa; a regular JIS No.2 diesel fuel (Sulfur 400 ppm) was used.

2.2 Experimental system and conditions

An external high-pressure fuel injection system was used in this study. Injection timing was set to ignite at

Table 2 Test conditions for combustion high speed photography

Item	Specifications
Comb. chamber	D = 100 mm, flat shallow dish with transparent bottom
Compression ratio	16
Charging conditions	from NA to 341.3 kPa
Injection pressure	100 MPa
Excess air ratio	3.5 constant
Engine speed	1000 rpm

TDC in real time by monitoring the heat release rate. Duration of the ignition delay was short under the supercharging condition; the injection timing was just before a few degrees of TDC. The supercharging system in this engine was an external super charge system driven by a motor. Its exhaust pressure was set equal to atmospheric pressure. Consequently, as the pumping work of the engine becomes great, the pumping work on the pressure diagram is excluded from IMEP, leaving only the work of the combustion area as indicated mean effective pressure (kPa; IMEP). The brake mean effective pressure (kPa; BMEP) of the single cylinder engine was obtained from IMEP from results of this experiment using the motoring friction of the multi-cylinder engine.

2.3 Observation of combustion

Only a few observations have described combustion under conditions of supercharging. Consequently, we used results of high-speed photography of diesel combustion from past studies as reference data for examining the same single cylinder engine⁽¹²⁾. Engine specifications for observation of the combustion conditions differ slightly from those of the performance test. Those different points are listed in Table 2.

The combustion chamber on the piston was observed from the bottom of the piston cavity: the combustion chamber shape was a flat and shallow dish; the cavity diameter was 100 mm; the bottom of the piston cavity was made of quartz glass; its compression ratio during the ob-

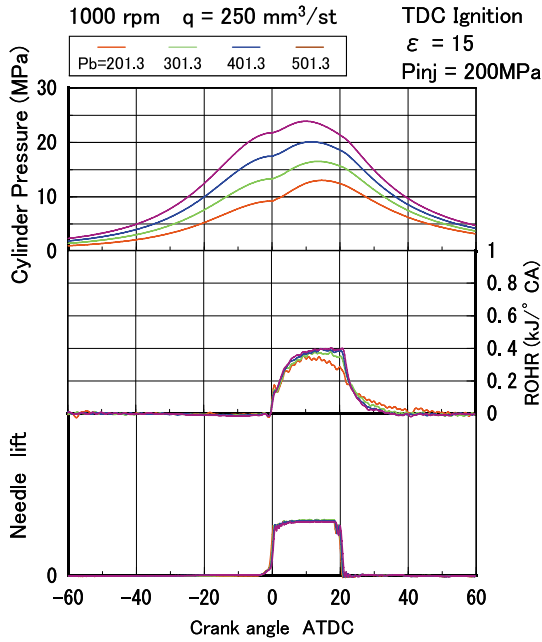

Fig. 2 Effect of boost pressures on cyl. press. and ROHR

servation test was $\varepsilon = 16$. The load was equivalent to 60%. The injection pressure was $P_{inj} = 100$ MPa under a constant condition of an air excess ratio $\lambda = 3.5$. The boost pressure varied from $P_b = 101.3$ kPa, which is the NA condition, to $P_b = 341.3$ kPa, which is the critical pressure for the strength of quartz.

3. Experimental Results

3.1 Pressure diagram and variation of heat release rate

Figure 2 shows results when changing the boost pressure P_b (kPa) under constant conditions of the injection quantity $q = 250$ mm³/st and $N_e = 1000$ rpm. The amount of air is twice that of the NA condition under $P_b = 201.3$ kPa. The heat release rate of that figure shows good burning. The burning becomes even better by increasing P_b ; the heat release rate approaches the injection rate.

Figure 3 shows results when changing the injection quantity from $q = 150$ to 350 mm³/st under the constant conditions of boost pressure $P_b = 501.3$ kPa and $N_e = 1000$ rpm. Because the amount of air in the cylinder was large under this condition and the injection duration was as long as 30 deg CA at $q = 350$ mm³/st, it was necessary to expand the total nozzle area to shorten the injection duration.

Figure 4 shows results when changing the engine speed from $N_e = 1000$ rpm to 1500 and 2000 rpm under constant conditions of boost pressure $P_b = 301.3$ kPa and injection quantity $q = 250$ mm³/st. The injection duration at injection quantity $q = 250$ mm³/st at $N_e = 2000$ rpm was as long as 40 deg CA and, as shown by the heat release rate, the burning duration was as long as 60 deg CA. Some

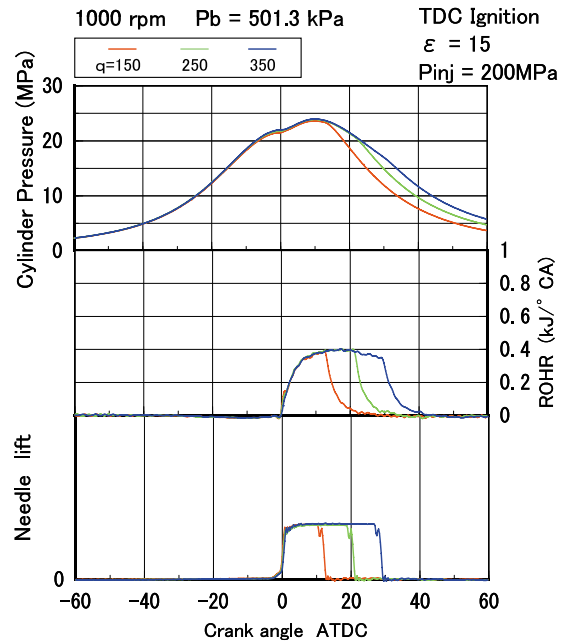

Fig. 3 Effect of fuel quantity on cyl. press. and ROHR

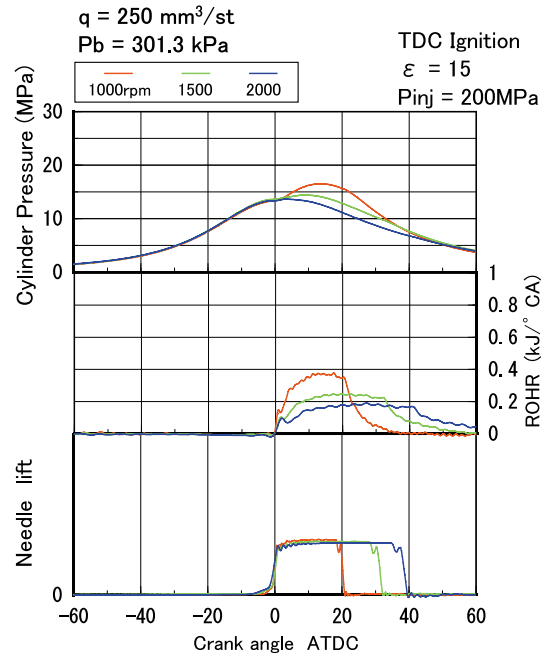

Fig. 4 Effect of engine speed on cyl. press. and ROHR

improvement is needed because this is not good combustion.

3.2 Low engine speed (1000 rpm)

Figure 5 shows the relationship of the brake thermal efficiency and P_{max} , increasing the boost pressure set as parameter to IMEP. Figure 6 shows the exhaust gases under the same condition. IMEP can be increased up to 3000 kPa under the injection quantity 350 mm³/st and the output power is equivalent to 282 kW (383PS) of a six-cylinder engine at 1000 rpm, considering friction.

The brake thermal efficiency reached its maximum at

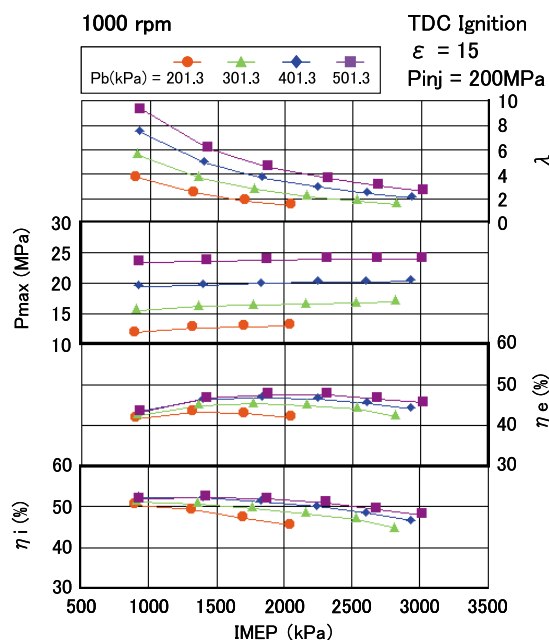

Fig. 5 Effect of boost pressures on P_{max} and thermal efficiency ($N_e = 1000$ rpm)

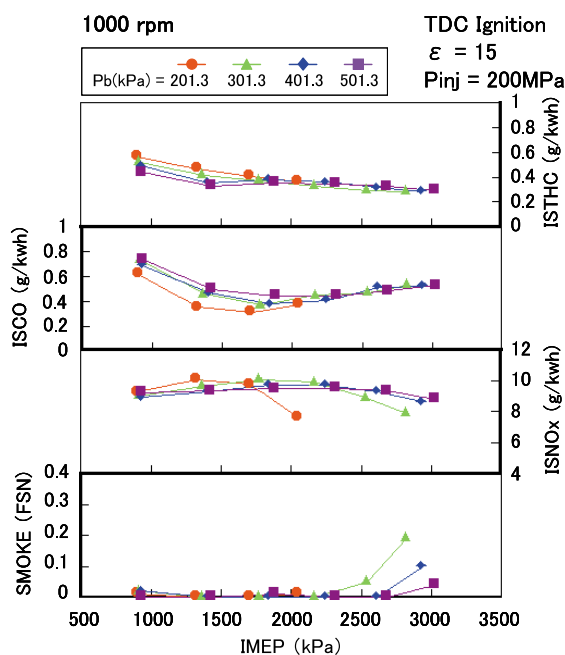

Fig. 6 Effect of boost pressures on exhaust emissions ($N_e = 1000$ rpm)

48% under the condition of IMEP 2000 kPa. It is an effective way to raise IMEP by boosting pressure to improve fuel consumption. The brake thermal efficiency rose gradually when the boost pressure was increased. However, the brake thermal efficiency increased slowly at more than $P_b = 401.3$ kPa. For that reason, the effective quantity of air sent to cylinder is expected to be up to four times that of an NA engine.

Furthermore, ISNO_x (indicated specific NO_x) per

output power was approximately 8–10 g/kWh; it did not change to a large extent by increasing boost pressure and fuel injection quantity. At the beginning of this experiment, we were concerned that the boost pressure would increase and that the oxygen concentration would also increase during lean combustion, engendering an increase of oxygen concentration and ISNO_x. Actually, ISNO_x did not increase, which was interesting. On the other hand, ISNO_x tends to decrease when IMEP increases because it decreases λ . Especially under $P_b = 201.3$ kPa, ISNO_x decreased at the maximum value of IMEP and the combustion was good without deterioration of smoke even at $\lambda = 1.5$.

Although the levels of ISCO and ISTHC per output power were low, it was necessary to lower the level of ISTHC further, considering the required future PM.

With the excess air, the level of smoke was very low because this experiment was performed using supercharging. The combustion was demonstrably good. As explained before, under $P_b = 201.3$ kPa, the combustion was good without deterioration of smoke even at the small value of $\lambda = 1.5$ at the maximum value of IMEP, but the air excess ratio may lower to $\lambda = 1.5 - 2.0$ at the condition of greater than $P_b = 301.3$ kPa. Thereby, the smoke would tend to increase at the maximum value of IMEP. The injection quantity was as large as $350 \text{ mm}^3/\text{st}$, as it never had been before under the condition that IMEP was increased by increasing boost pressure. Consequently, the injection duration lengthened greatly. During that time, the piston would descend. Presumably, the fuel spills from the piston cavity and degrades the combustion, thereby generating smoke. A combustion must be found that does not produce smoke at the $\lambda = 1.8$ level.

3.3 Medium engine speed (1500 rpm)

Figures 7 and 8 show results of $N_e = 1500$ rpm. IMEP is 2500 kPa at the injection quantity $q = 305 \text{ mm}^3/\text{st}$; the output power is 343 kW, equivalent to that of a six-cylinder engine at 1500 rpm. The test result pattern resembles the case of $N_e = 1000$ rpm; the maximum brake thermal efficiency at 46% can be obtained at IMEP = 1500–2000 kPa. Because ISNO_x has a decreasing tendency against the increase of IMEP, the increase of IMEP is preferable. Nevertheless, it is necessary to find a method to decrease the smoke because the decrease of ISNO_x is presumed to result from the decrease of λ and engenders increased smoke.

3.4 High engine speed (2000 rpm)

Figures 9 and 10 show results of $N_e = 2000$ rpm. IMEP was 1850 kPa at the injection quantity $q = 240 \text{ mm}^3/\text{st}$. The output power 317 kW equivalent to that of a six-cylinder engine. The injection duration was long because of the specification of the existing nozzle. Because the injection quantity was limited, the maximum value of IMEP was 1850 kPa. Because the friction in-

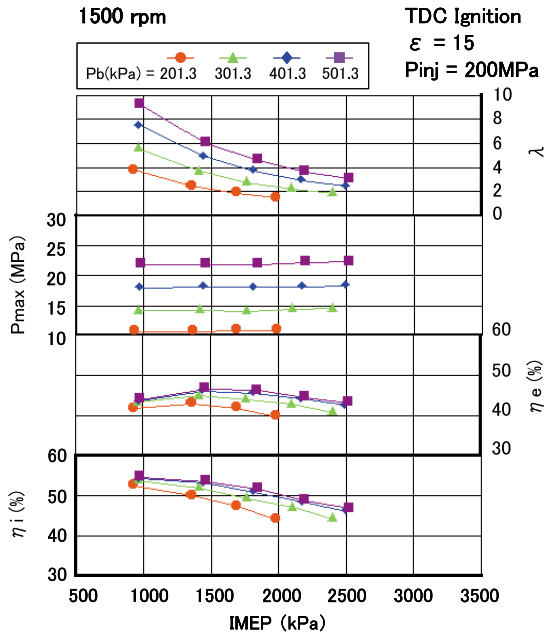

Fig. 7 Effect of boost pressures on P_{max} and thermal efficiency ($N_e = 1500$ rpm)

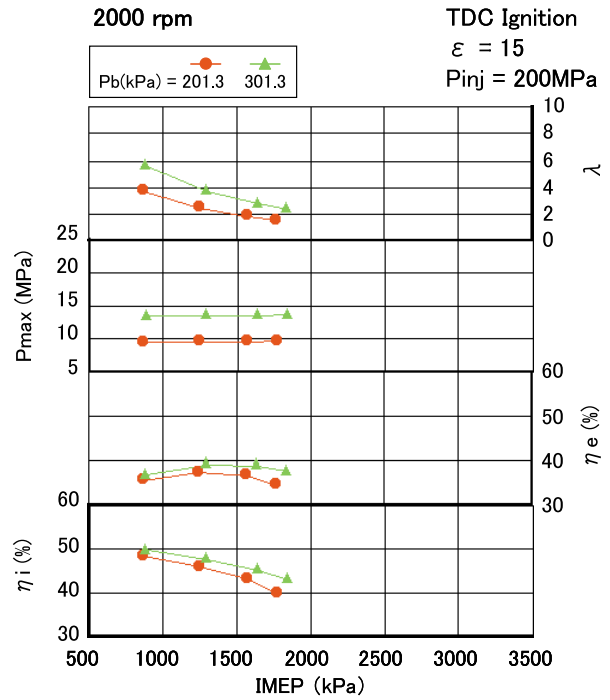

Fig. 9 Effect of boost pressures on P_{max} and thermal efficiency ($N_e = 2000$ rpm)

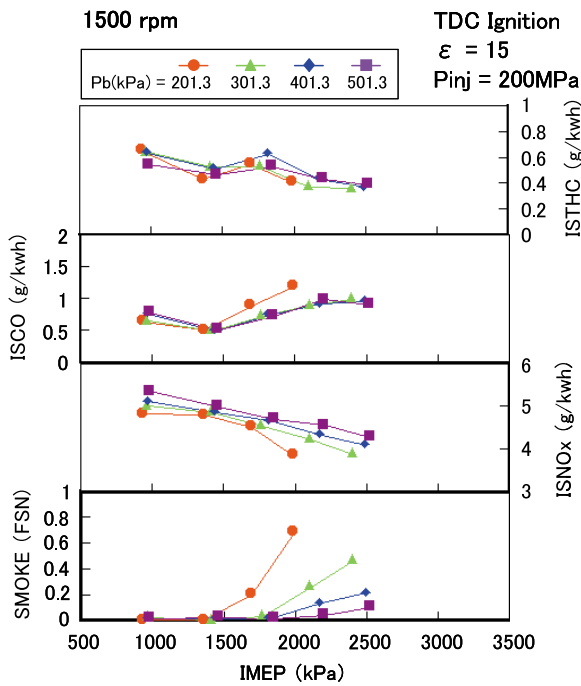

Fig. 8 Effect of boost pressures on exhaust emissions ($N_e = 1500$ rpm)

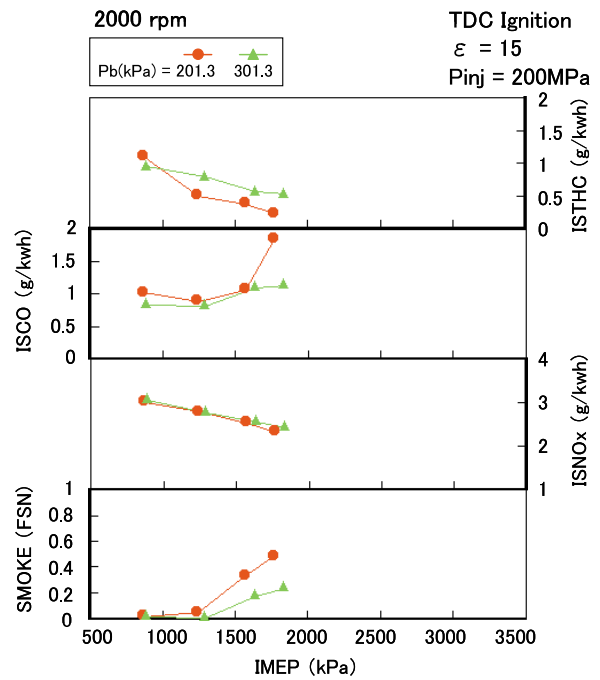

Fig. 10 Effect of boost pressures on exhaust emissions ($N_e = 2000$ rpm)

creased concomitant with the speed, the maximum value of the brake thermal efficiency was 39%.

On the other hand, the level of ISNO_x was low, and ISNO_x decreased against the increase of IMEP. As the injection duration became long at a high speed, the smoke increased remarkably when the injection quantity increased. Accordingly, high BMEP engine should afford good injection characteristics of both high speed and high load point, and low speed and low load point. In addition,

the injection quantity should cover the large range from idling to 350 mm³/st.

3.5 Combustion retardation (1 000 rpm)

Effects of combustion retardation by fuel injection timing retarding engine performance and exhaust emissions in 1 000 rpm are shown respectively in Figs. 11 and 12. In those figures, the parameter is fuel injection quan-

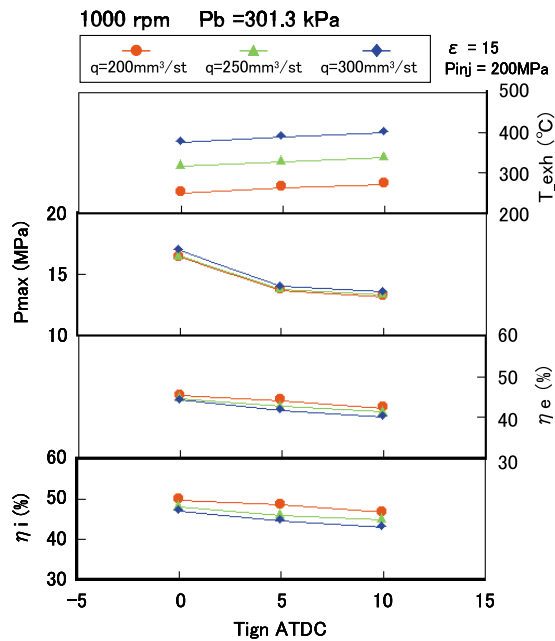

Fig. 11 Retardation of combustion timing effects on P_{\max} and thermal efficiency η_e

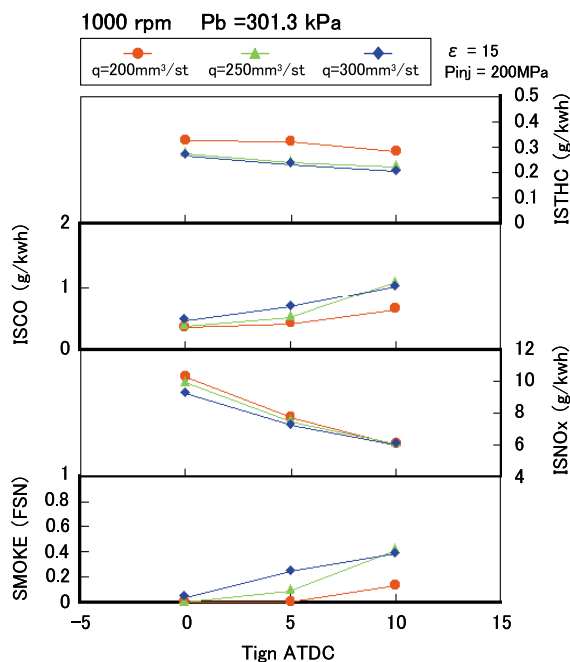

Fig. 12 Retardation of combustion timing effects on exhaust emissions

tity, which is varied from 200 to 300 mm^3/st . The purpose of combustion retardation is the reduction of ISNOx and the reduction of ISNOx is 40% by 10 deg of combustion retardation. Demerits of exhaust emissions are increased ISCO and smoke concentration. Considering future restrict emission regulation, smoke concentration should be decreased to reduce the mass of particulate matter. For keeping low smoke levels, the limit of the combustion start is 5 deg ATDC and the limit of fuel quantity is 250 mm^3/st

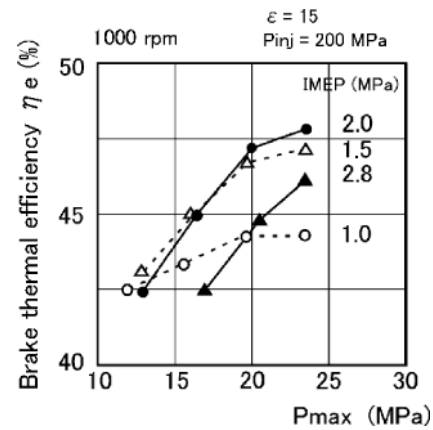

Fig. 13 Improvement in brake thermal efficiency by P_{\max} increase ($N_e = 1000$ rpm)

in $P_b = 301.3$ kPa condition. Maintaining these conditions, the reduction of ISNOx can be 25% because of the 5 deg combustion retardation. Keeping high boost pressures, ISNOx can be reduced greatly through use of combustion retardation. In contrast, brake thermal efficiency in $q = 250$ mm^3/st deteriorates 2.5% by 5 deg combustion retardation. Consequently, it causes a 5% of increase in fuel consumption.

Because of the combustion retardation, P_{\max} is reduced to 3.5 MPa from TDC to 5 deg ATDC of ignition, but P_{\max} does not change after 5 deg ATDC of ignition because the P_{\max} changes to the peak of compression pressure from the peak of combustion pressure.

4. Consideration

4.1 P_{\max} and brake thermal efficiency

Although supercharging boosts the intake air, P_{\max} is increased. At the same time, the brake thermal efficiency is also improved. By increasing P_{\max} , the brake thermal efficiency shown in Fig. 13 was obtained by boosting P_{\max} and increasing IMEP. From this result, the thermal efficiency, namely, fuel consumption, can be improved by extending P_{\max} to 20–25 MPa and using the high thermal efficiency range of IMEP = 1.5–2.0 MPa as the running range in vehicle.

4.2 Reduction of exhaust emissions

Obtained from this experiment, $P_b = 201.3$ and 301.3 kPa, the values of NOx without after-treatment are allowable under current regulations. It is necessary to decrease the NOx value in the future by means of the large volume of EGR because there is a practical limit to combustion retardation.

Furthermore, the increase of the air amount by raising the boost pressure reduces smoke. However, in the case where $P_b = 201.3$ kPa at $N_e = 1500$ rpm, NOx decreases, but smoke increases when IMEP exceeds 1500 kPa. This smoke is attributable to the decrease of the excess air ratio caused by the increase of IMEP. It is necessary to find a

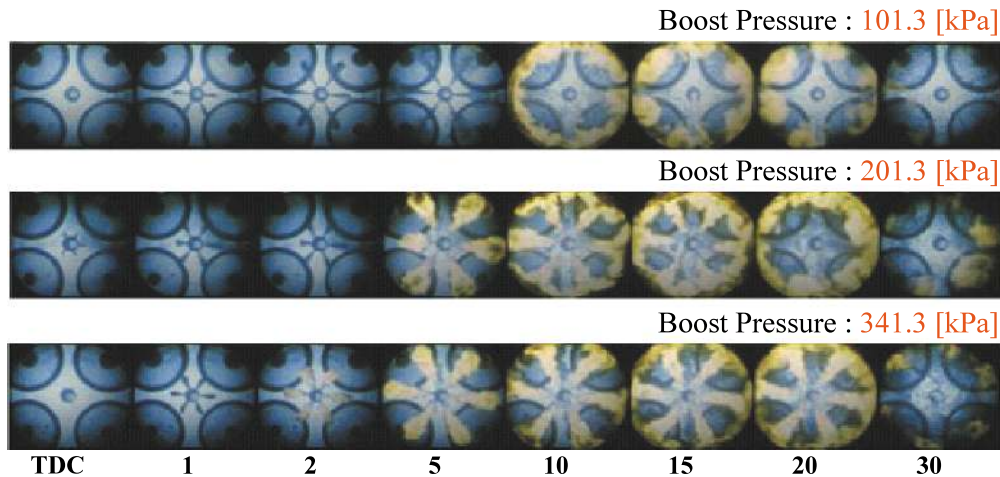

Fig. 14 High-speed photographs of diesel combustion ($P_{inj} = 100 \text{ MPa}$, $\lambda = 3.5$, $\varepsilon = 16$, $N_e = 1000 \text{ rpm}$)

combustion level at which smoke does not increase at the level of $\lambda = 1.8$.

4.3 Observation of combustion

Figure 14 shows results of combustion observations using the single cylinder engine. This observation was conducted under the same conditions as those for the performance test, but the injection pressure was 100 MPa and the boost pressure was increased to $P_b = 341.3 \text{ kPa}$ from the level of NA. Results of the combustion observation provided many useful facts for consideration. If the boost pressure were increased, ignition would occur extremely fast. The spray enters the flame and the density difference between the flame and the air becomes greater. The combustion duration in high pressure condition lengthens because of the large amount of fuel. Furthermore, it is necessary to promote the mixing of fuel spray and air using a new method.

4.4 Improvement items

The injection duration was too long under the engine speed of $N_e = 2000 \text{ rpm}$ in this test. A shorter duration is necessary to increase the total nozzle area. It is important to consider the existing desirable balance of combustion lest the total nozzle area be increased too much. Moreover, the excess air ratio decreases and thereby increases smoke when the injection quantity increases. It is necessary to find a combination of an injection system and a combustion chamber that will not allow smoke to increase with an air excess ratio of $\lambda = 1.8$.

5. Summary

Engine performance and exhaust emission characteristics were examined by inducing the amount of intake air up to five times that of an NA engine and by increasing the injection quantity up to $350 \text{ mm}^3/\text{st}$ under the condition of 200 MPa injection pressure.

(1) Combustion was improved by increasing the in-

take air amount. Consequently, a sharp heat release was obtained and thermal efficiency was improved. By increasing the amount of air and by increasing P_{max} , brake thermal efficiency was improved.

(2) For high boost diesel combustion, by increasing the air amount, the NOx weight per unit of output power did not increase. Furthermore, smoke was reduced greatly by increasing the air amount. Experiments proved that reductions of both NOx and PM are achieved by high boost and lean combustion.

Acknowledgments

The authors wish to thank New ACE's investors and the project to promote development of Next Generation Low Emission Vehicles of Ministry of Land, Infrastructure and Transport, who financially supported this study.

References

- (1) Kobayashi, A. and Suzuki, T., Progress of Heavy Truck Diesel Engines in Japan, SAE Paper 880466, (1988).
- (2) Suzuki, T., Sato, A. and Suenaga, K., Development of a Higher Boost Turbocharged Diesel Engine for Better Fuel Economy in Heavy Vehicles, SAE Paper 830379, (1983).
- (3) Sato, A., Suenaga, K., Noda, M. and Maeda, Y., Advanced Boost-up in Hino EP100-II Turbocharged and Charge-Cooled Diesel Engine, SAE Paper 870298, (1987).
- (4) Tsujita, M., Niino, S., Ishizuka, T., Kakinai, A. and Sato, A., Advanced Fuel Economy in Hino New P11C Turbocharged and Charge-Cooled Heavy Duty Diesel Engine, SAE Paper 930272, (1993).
- (5) Aoyagi, Y., Challenge to Super High Thermal Efficiency of Diesel Engine, Journal of the JSME, (in Japanese), Vol.105, No.1007 (2001), pp.667-671.
- (6) Japan Ministry of Environment, About New Automotive Emission Standards in Future (5th Report), (in Japanese), (2002).
- (7) Aoyagi, Y., Present and Future Technologies for Re-

- ducing Exhaust Emissions in Diesel Engines, Journal of JSAE, (in Japanese), Vol.55, No.9 (2001), pp.10–16.
- (8) Sugihara, H., Nakagawa, H., Shouyama, K. and Yamamoto, A., Hino New K13C Diesel Engine Equipped with Common-Rail Type Fuel Injection Equipment, Engine Technology, (in Japanese), Vol.01, No.04 (1999), pp.40–45.
- (9) Itoh, S. and Nakamura, K., Reduction of Diesel Exhaust Gas Emission with Common Rail System, Journal of JSAE, (in Japanese), Vol.55, No.9 (2001), pp.46–52.
- (10) Stover, T., Reichenbach, D. and Lifferth, E., The Cummins Signature 600 Heavy Duty Diesel Engine, SAE Paper 981035, (1998).
- (11) Knecht, W., European Emission Legislation of Heavy Duty Diesel Engines and Strategies for Compliance, Proceedings of the Thermofluidynamic Processes in Diesel Engines (THIESEL'2000), (2000), pp.289–302.
- (12) Aoyagi, Y., Asaumi, Y., Kunishima, E., Harada, A., Morita, A. and Seko, T., Visualized Analysis of a Pre-Mixed Diesel Combustion under the High Boosting Engine Condition, COMODIA2001, (2001), pp.434–440.
-