

Different Possible Ways for Saving Energy in the Cement Production

Aly Moustafa Radwan

Chemical Engineering & Pilot Plant Dept., National Research Center, Egypt

ABSTRACT

In terms of absolute consumption, the cement industry occupies a front position in the ranks of energy consumed industries. The total energy costs (thermal and electrical) make up about 30 to 40 percent of the total production costs of cement. This is why efficient energy utilization has always been a matter of priority in the cement industry. Cement manufactures requires very high temperatures to initiate the reaction and phase changes necessary to form the complex mineral compounds that give cement its unique properties. Pyro-processing in large rotary kiln is the operational step that provides the energy and environmental conditions necessary for the reaction and phase change. This operation dominates the energy consumption and environmental impacts associated with the manufacture of the cement. Improvement of energy efficiency reduces the emission of carbon dioxide from fuel and electricity use and may also reduce the costs of producing the cement. Process improvement may be attained by energy management, applying more energy efficient process equipment and by replacing old installations by new ones or shifting to complete new types of cement production processes, cement kiln optimization process, performing the research and development necessary to prepare and burning the alternative fuels in cement kiln and to develop new cement manufactures.

INTRODUCTION

Cement clinker is manufactured primarily from limestone, clay, sand and iron oxide-bearing as raw materials. These materials are blended and finely comminuted to form the raw meal. The process of manufacture of cement consists essentially of crushing and grinding of the raw materials, mixing them intimately at certain proportions and burning them, usually in a rotary kiln at a temperature of approximately 1450 °C. The material sinters and partially fuses to promote the formation of the clinker phases. The principal phases in the cement clinker are tri-calcium silicate, di-calcium silicate, tri-calcium aluminate and calcium aluminoferrite. The clinker is then cooled and ground to fine powder with the addition of a few percent of gypsum. The resulting product is so called commercial Portland cement [1].

During the heating up and burning process, decomposition reactions, phases transformations and formation of new phases occur. These phenomena influence each other. Regarding, the energy consumption in the kiln plant, the important aspects are the enthalpies of the reactions, which may be endothermic or exothermic (2).

Table (1) gives an overview of the important thermal reactions occurring during cement manufacture process. There are various processes for cement clinker manufacture e.g. wet, semi-wet, semi dry and dry process. The dry process is divided into three main types, namely, long dry process, dry process with cyclone preheate without preclinker, dry process with cyclone preheater with or without tertiary air duct. Such process differ mainly in the state of the feed to the rotary kiln which ranges from slurry with approximately 35% water content in the wet process to a raw meal that is a calcined to a great extent in the dry process with pre-calciner. The dry process with pre-calciner is the most process for the clinker manufactures due to its several advantages (3-5).

The basic principle in the kiln plant with pre-calciner, is that substantial fuel energy is introduced into the feed materials outside the rotary kiln, so that calcium carbonate in the materials is already de-carbonated to a great extent before entry into the rotary kiln. This pre-calcination step is achieved in the so called secondary firing system (calciner) as distinct from the main or the primary firing system in the kiln. This calciner is operated between the rotary kiln and the pre-heater.

Figure (1) shows a diagram of cement kiln plant with precalciner having a tertiary air duct. As shown from the diagram, the kiln plant consists of a multistage cyclone pre-heater and heated by the gases of the combustion arising from primary and secondary firing systems (rotary kiln, calciner). The preheated feed material enters the calciner where it is wholly or partially calcined. The reactions in the calciner is supplied by the kiln exit gas and by the fuel fired in the calciner. The solid material (hot-meal) and the gas leaving the calciner are separated from each other in the bottom cyclone. The solid materials is fed to the rotary kiln and the gases passes to the upper stage of the pre-heater. In the rotary kiln, solid materials is almost completely calcined in counter current flow with combustion of the gases from the primary firing burner (rotary kiln) and is heated to the clinkering temperature causing partial fusion which promotes the formation of the clinker phases [4].

Cooling of the clinker is achieved through two successive stages. First, the clinker is cooled in the rotary kiln from its clinkering temperature in counter current flow with the secondary air flow before dropping into the cooler. Second, the clinker is cooled in the cooler to its final exit temperature by induced cooling air through the cooler, which is wholly or partially, according to the type of the cooler, is used as pre-heated combustion air to the rotary kiln and calciner [5].

The advantages of the dry process with pre-calciner can be summarized as follows:

- It is possible to operate the calciner with low grade fuel or waste derived relatively low calorific value which can not be used in the rotary kiln. This is due to the relatively low temperature of calcium carbonate dissociation in the calciner around 820 °C.
- The dimension of the kiln can be reduced for the same productivity or the productivity can be increased for the same dimension of the kiln, which means high productivities of the process. This is due to the fact that the calcinations of the feed materials in the calciner proceed more rapidly and with smaller temperature difference between gas and solid than in the rotary kiln. This is also because, from the thermodynamics point of view, fuel energy is supplied to the calciner at that point where it is needed for the endothermic reaction of calcium carbonate decomposition. The thermal loads in the rotary kiln are greatly reduced and consequently the quantities of the required refractory are reduced.
- Accordingly, the advantages of the pre-calcining method result in low capital expenditure and low operating cost of the kiln plant with high attained productivities.

On the other hand, the operation of secondary firing system, however, affects the operational behaviour of the kiln plant. This is due to that raw materials and fuel fed to the cement burning process contains various amounts of secondary constituents such as chlorides, alkalis and sulphates . They are partially vaporized in the high temperature zone and condensed again in the colder temperature zone within the burning system. They therefore lead to form re-circulating cycle which can be disturb the kiln operation by the formation of coating or can have a detrimental effect on the clinker quality. From these points of view, it is necessary to use a method to keep the re-circulating systems within tolerable limits. This requires by pass devices which can be designed in various different ways.

In addition, the operation of secondary firing system is affected by the proportion of secondary fuel in the calciner. If too high proportion of fuel in the secondary firing system claimer, coating formation in the part of the preheater-calciner and at the kiln inlet and consequently seriously up setting kiln operation may occur.

In fact, cement clinker burning is high complex process because the various sub-processes such as heating, calcining, clinkering and cooling which do not take place consecutively but to some extent proceed simultaneously and influence each other.

2. REVIEW FOR ENERGY SAVING IN CEMENT KILN

2.1 Modeling Balance of Cement Kiln

The share of energy consumed in a cement clinker kiln plant attains 70-78% of the overall energy consumed in the process of cement production as a whole. The residual (22-30%) is the share of electrical energy. On the other hand, for the burning of the clinker kiln plant, thermal energy represents 92-96% of the required energy and the electrical energy accounts for only 4-8%. Therefore, potentials for reducing specific heat consumption in the kiln plant deserve priority (6-10). Accordingly, the considerations presented in this article review are related to the specific

fuel energy consumption in cement kiln plants. The effect of the different factors on the fuel energy consumption in cement kiln plants is widely discussed with the aid of mathematical models in the literature.

A mathematical model of cement kiln plant without precalciner has been established by Elkjore [11]. The effect of different parameters on the specific heat consumption and preheater exit gas temperature are investigated by the author with the aid of that model. The investigated parameters were the amount of the excess air, primary air, false air at the cement kiln, false air in the pre-heater, wall heat losses and kiln gas bypass ratio. Some operation conditions of the process have been kept at a certain values such as the degree of calcinations in the bottom stage cyclone pre-heater, hot meal temperature at the kiln inlet, kiln gas temperature, dust load in the kiln exit gas. Results of the calculation showed that the specific fuel energy consumption increases with the increases of excess air, primary air, and false air at the kiln inlet, cooler energy loss, false air in the pre-heater and the kiln gas by pass ratio. On the other hand, the pre-heater exit gas temperature increases with the increase of the excess air, false air at the kiln inlet. It decreases with the increase of the false air in the pre-heater and with the kiln gas by pass ratio.

A balance model of cement kiln plant with pre-calciner with tertiary air has been established by Ghazi [12]. The effect of various factors such as secondary fuel energy proportion, number of stages of cyclone pre-heater, kiln gas by pass ratio and the type of the fuel used on the energy consumption and the pre-heater exit gas temperature were investigated. Some operation conditions of the process have been specified at certain values, such as the combustion excess air factors, clinkering temperature, wall heat loss and cooler efficiency. By applying the model on different kiln plants in Egypt and other kiln plants in Germany, the result of calculations showed that the difference between theoretical calculated and measured values of fuel energy consumption are in the range of 0.10 to 5.8 %. The change in the energy losses from the individual sections of the system affects on the fuel consumption by different degrees.

A balance model of cement kiln plant with pre-calciner with tertiary air has been established by Gardeil *et al* [13]. The effect of various factors such as secondary fuel energy proportion, number of stages of cyclone pre-heater, kiln gas by pass ratio and the type of the fuel used on the energy consumption and the pre-heater exit gas temperature were investigated. Some operation conditions of the process have been specified at certain values, such as the combustion excess air factors, clinkering temperature, wall heat loss and cooler efficiency. The model was based on various assumptions namely, the de-carbonation behavior of the feed material in the calciner and the temperature difference between the materials and the exit gas at the kiln inlet. The results indicated that the fuel energy consumption and the pre-heater exit gas temperature increases with the increase of the fuel energy proportion. This is in fact due to the increase of the hot meal temperature in the bottom stage cyclone pre-heater.

Thermal analysis of cyclone pre-heater system based on a model has been established by Peng Fei [14]. The model was used to study the effect of dust loads at kiln inlet, precipitation efficiency of the cyclones and number of the stages of cyclone pre-heater on the fuel consumption. Some operation conditions of the process have been kept constant at certain values, such as kiln exit gas temperature, heat of reaction, wall heat losses, clinker temperature at the kiln outlet, and efficiency of the cooler. The results showed that with the increase of dust load of kiln exit gas by 0.1 kg dust/kg clinker, the specific energy consumption increases by about 13-17 KJ/kg clinker. The results indicated that the effect of precipitation efficiency of the lower cyclones on the fuel consumption is stronger than of the higher located cyclones.

From industrial trial in cement kiln plants with pre-calciner equipped with tertiary air duct (productivity ranging from 1041 to 3427 ton of clinker/day). They found that the energy loss from the pre-heater is about 0.75-1.25 MJ/kg clinker, the loss through the walls of the rotary kilns is about 0.2-0.55 MJ/kg of clinker, loss from the cooler is about 0.4-0.65 MJ/kg clinker. The change in the energy losses from the individual sections of the system affects on the fuel consumption by different degrees. Furthermore, on applying the mathematical models, the effect of different factors on the apparent degree of calcinations and secondary fuel energy proportion in the calciner have been estimated. Such factors were enthalpy of the kiln exit gas, potassium chloride cycle between kiln and the calciner and the enthalpy of the tertiary air. The results showed that the secondary fuel energy proportion supplied to the calciner decreases with the increase of the kiln exit gas temperature and with the temperature of the tertiary air. On the other hand, the degree of calcinations in the calciner increases with the increase of the kiln exit gas temperature and with KCl concentration in the hot meal [3].

2.2 Circulating Element in Cement Kiln

The raw materials and the fuels fed to the cement burning process contain various amounts of secondary constituents presents usually impurities such as chlorine, alkalis and sulphates, which may form more or less volatiles compounds. In a cement dry process with pre-calciner, on exposure to a continuously increasing temperature, those compounds evaporate or dissociate to different extents according to their nature. The resulting vaporizes and gases products flow to the pre-heater pre-calciner with the kiln gas, where, they condense on or react with suspended particles of the meal. Successive evaporation and condensation of secondary constituents between the kiln and the

pre-heater pre-calciner form what is known as the circulating phenomena. In fact, there are two cycles occurring in a clinker burning system, namely, internal cycle and external cycle. The internal cycle is formed by vaporization of the secondary constituents in the rotary kiln and the condensation in the colder zones of the process. On the other hand, the external cycle is caused through the return of the dust transferred with pre-heater exit gas to the raw mixture via the raw mill, the cooling of tower, the filter. The behavior of circulating elements depends on its degree of volatilization, its extent of adsorption by the hot meal and the condensation in the pre-heater, mill and filter and also by the degree of combination in the clinker [15].

Intensive internal cycles of the secondary constituents may cause serious operational problems due to coating formation, clinker quality deterioration in addition to the emission problems. The intensity of the cycles depends on the following factors:

The intake of alkalis, sulphur and chlorine in the raw materials and fuel, the burning temperature, the kiln gas temperature, the throughput of materials, the gas/materials temperature gradients, and the specific surface of the kiln feed.

Table (1) Reactions of Raw Materials and Reactions Enthalpies in Cement Clinker

| Reaction | Equation of reaction | kJ/kg clinker |
|-------------------------------------------------|------------------------------------------------------------------------------------------------------------------------------------------------|---------------|
| Formation of oxides and decomposition reactions | | |
| Volatilization of H ₂ O | H ₂ O _{liq.} → H ₂ O _{vap.} | 4 |
| Kaolinite decomposition | Al ₂ O ₃ .2SiO ₃ .2H ₂ O → Al ₂ O ₃ +2SiO ₂ +2H ₂ O | 78 |
| Mg CO ₃ dissociation | Mg CO ₃ → MgO + CO ₂ | 22 |
| CaCO ₃ dissociation | CaCO ₃ → CaO+ CO ₂ | 2111 |
| Formation of intermediate products | | |
| Formation of CA | CaO+Al ₂ O ₃ → CA | -8 |
| Formation of C ₂ F | 2CaO+Fe ₂ O ₃ → C ₂ F | -6 |
| Formation of C ₂ S | 2CaO+ SiO ₂ → β C ₂ S | -493 |
| Clinkering reactions | | |
| Formation of C ₄ AF | CA+C ₂ F+ CaO → C ₄ AF | 3 |
| Formation of C ₃ A | CA+ CaO → C ₃ A | 1 |
| Formation of C ₃ S | β C ₂ S +CaO → C ₃ S | 35 |
| Overall reactions | Kiln meal → clinker | 1747 |

Table (2) Average and Best Practice Energy Consumption Values for Cement Plant by Process

| Process | Unit | India Average | World Best Practice |
|------------------------------------|--------------------|---------------|---------------------|
| Raw Materials Preparation | | | |
| Coal mill | kWh/t clinker | 8 | 2.4 |
| Crushing | kWh/t clinker | 2 | 1.0 |
| Raw mill | kWh/t clinker | 28 | 27 |
| Clinker Production | | | |
| Kiln & cooler | Kcal/kg of clinker | 770 | 680 |
| Kiln & cooler | kWh/t clinker | 28 | 22 |
| Finish Grinding | | | |
| Cement mill | kWh/t cement | 30 | 25 |
| Miscellaneous | | | |
| Utilities: mining & transportation | kWh/t clinker | 1.6 | 1.5 |
| Utilities: packing house | kWh/t cement | 1.9 | 1.5 |
| Utilities: misc. | kWh/t cement | 2.0 | 1.5 |
| Total Electric | kWh/t cement | 95 | 77 |

Table3: Fuel Energy Consumption in Different Cement Kiln Plants

| Heat energy, KJ/kg of clinker | With grate cooler | With rotary cooler |
|-------------------------------|-------------------|--------------------|
| Rotary kiln | 400 | 315 |
| Cooler | 500 | 500 |
| Preheater | 875 | 855 |
| Heat of reaction | 1700 | 1760 |
| Bypass system | 250-350 | 250-350 |

Table 4: Fuel Energy Consumption of Rotary Kiln Plant with Cyclone Pre heater

| Energy loss , kJ/kg | By Gardiek | By Ghazi |
|------------------------------------|------------|----------|
| Exhaust preheater energy loss | 0.87 | 0.74 |
| Wall heat loss of the first stage | 0.22 | 0.20 |
| Wall heat loss of the second stage | 0.44 | 0.40 |
| Wall heat loss of the third stage | 0.76 | 0.63 |
| Wall heat loss of the forth stage | 1.18 | 0.96 |
| Rotary kiln wall heat loss | 1.18 | 0.96 |
| Cooler energy loss | 1.46 | 1.47 |
| Bypass energy loss | ----- | 0.46 |

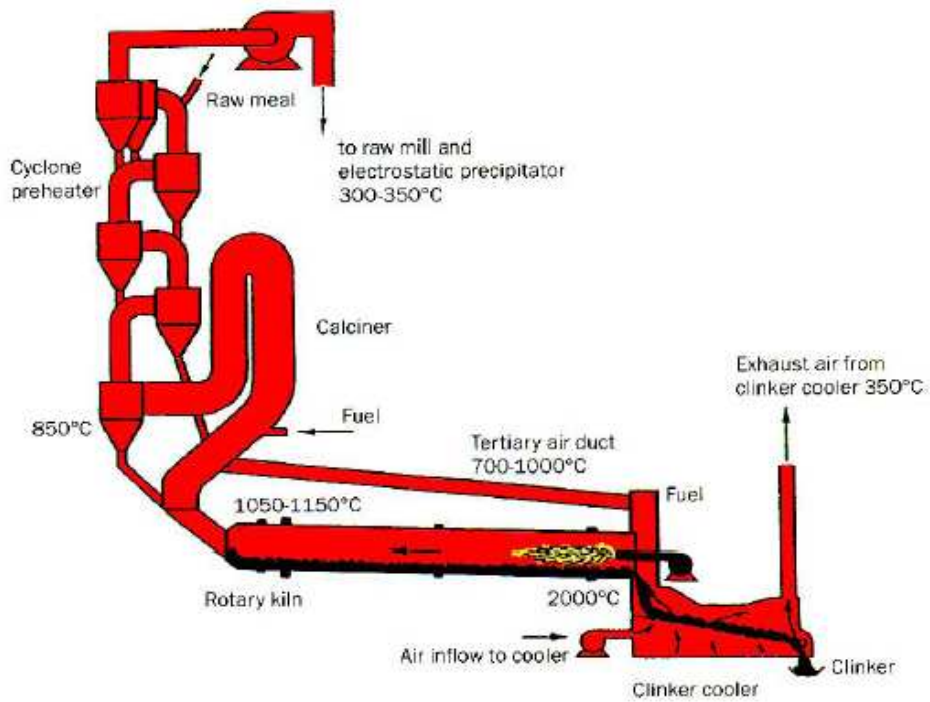

Figure1. Flow Diagram of Cement Kiln Plant with Cyclone Pre-heater, Calciner and Tertiary Air Duct

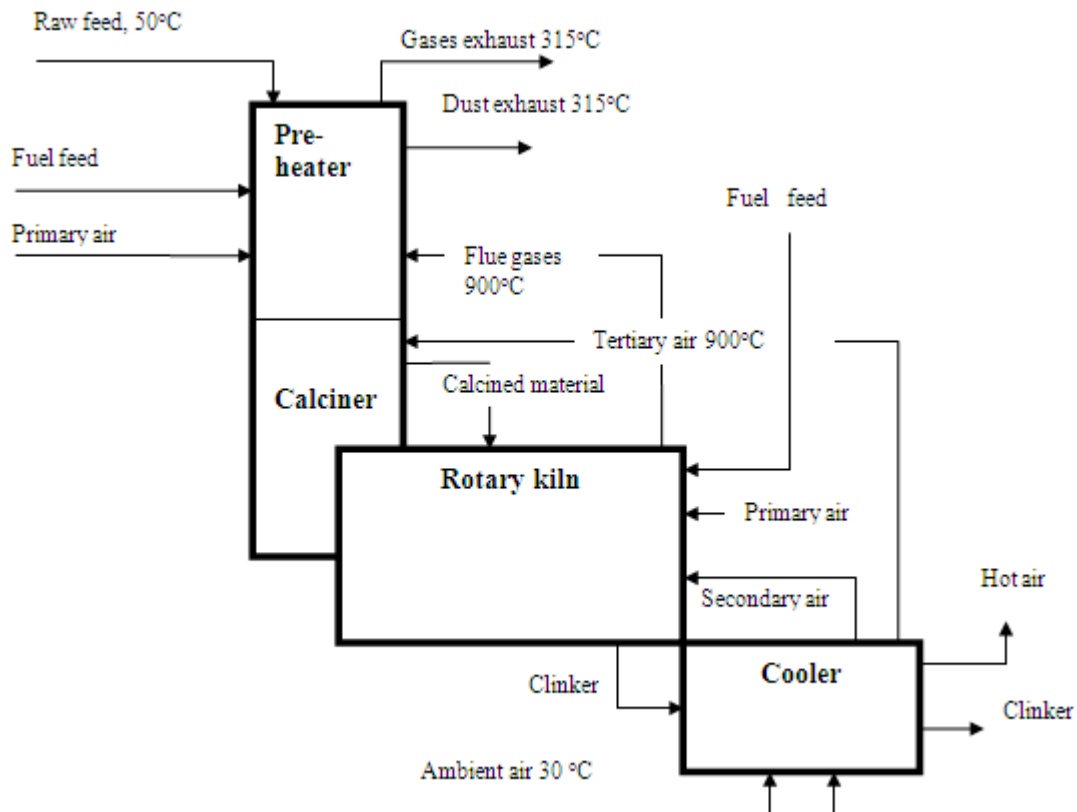

Figure 2. Flow Diagram for the Kiln Cement System

The following substances are to be regarded as undesirable when present in quantities of the order of magnitude indicated that: alkalis (K_2O , Na_2O) with total input 1-20 g/kg clinker, sulphates (SO_3) with total inputs of 10-30 g/kg clinker, chlorine with total input of 0.4-8 g/kg clinker [2,4].

2.3 Clinker Cooling

Clinker cooling in the cement industry has the following tasks to perform; cooling the clinker produced in the kiln to the lowest possible temperature, pre-heating the secondary and tertiary air required for the combustion process to the highest possible temperature, cooling the clinker at such a rate, which are suitable to give the required properties of the clinker.

Hansen [16] stated the requirements of clinker cooler to cool clinker down to a suitable temperature. Such requirements are: Cooler operation must not affect the kiln operation; Cooler must be easy to operate and easily incorporated in automatic control., Cooler must be study in design, reliable in operation, easy and economic in maintenance, compact, easy to clean, dust free and low level of noise.

2.4 Process Control

The main controlled variables of a cement kiln are the burning temperature and the exit gas temperature. The manipulated variables are the fuel rate and the kiln feed rate. The oxygen content in these gases is also usually controlled using the exhaust fan speeds but this control loop already existing in the industry [17].

The cement properties like hydraulic, highly depend on the clinker quality which is directly related to the burning temperature profile. Therefore, this temperature profile has to be carefully controlled to produce high quality clinker and to reduce the disturbance effects such as variation in the raw materials composition and in the combustible properties [18].

In the literature, few dynamic model of the cement kiln are proposed. The simulation of the behavior of the cement kiln is performed using a dynamic model. This model is based on Spang approach but modifications have been introduced to make the model more realistic and more appropriate to design a control structure. This model of cement kiln consists in a set of partial differential equations describing the heat and mass transfers occurring in the kiln [18].

Witsel *et al* have made contribution to the control of a rotary cement kiln, a simulation study of a multi-loop control scheme, designed using a frequency approach [19].

Recent studies on the modeling of cement manufacturing reported in the literature are mostly based on computational fluid dynamics and they mainly study aerodynamic behavior of a particles in the preheating system, the shape and the temperature of the flame in the combustion zone, coal combustion itself as well as oxygen enrichment in the burning zone and not so much the thermodynamics and clinker chemistry taking place in the kiln system [20].

Kaantee *et al* [21] have studied the modeling of a cement manufacturing process to study possible impacts of alternative fuels. The clinker burning process is well suited for the use of various alternative fuels because of the long residence times in both rotary kiln and gas channels. The model was used to optimize process control and the use of alternative fuels while maintaining clinker product quality. It was also to predict the possible changes in the combustion, pre-calcining and clinker formation process.

Radwan *et al* [22], have been studied the modeling, simulation and control of the cement kiln systems. A transient model is derived for cement kiln systems. In this work, two control loops was studied the temperature of the pre-heater calciner loop and the sintering zone temperature outlet of rotary kiln loop. The flow rate of the fuel is manipulated variable for the previous two control loops, but the disturbance variables are combustible properties of the fuel and the reaction energy due to the change the composition of the raw materials. The control system using PID controllers, which is robust with good performance in either set point tracking or disturbance rejection cases.

3. MASS AND HEAT BALANCE OF CEMENT KILN

In a typical dry process kiln systems, the feed materials are preheated by the hot gases from rotary kiln. A secondary burner in the pre-calciner is included to improve energy efficiency. The mixture of the preheated and pre-calcined materials enters the rotary kiln, which is a counter flow reactor. Fuels together with air enter from the opposite end. The solid feed is heated to an extremely high temperature in the burning zone such that raw materials react and form nodular clinker. Clinker exits the kiln at about 1350 °C and is cooled down to less than 120 °C by cross flowing air. Part of the heated air from the cooler enters the kiln, another portion flows to the pre-calciner; the rest is released as exhaust air (23-24).

The rotary kiln system considered for the energy audit is schematically shown in Figure.2.

3.1 Mass Balance of Cement Kiln

The mass balance for both preheater, rotary kiln and cooler is shown as the following:

3.1.1 Mass Balance of Preheater Calciner

Inlet mass = outlet mass

$$\text{Inlet mass} = m_c + m_{ra} + m_{kg} + m_{kd} + m_{tair} + m_{pair}$$

$$\text{Outlet mass} = m_{ex\ gases} + m_{hc} + m_{pd}$$

3.1.2 Mass Balance of Rotary Kiln

$$\text{Inlet mass} = m_k + m_{p\ air} + m_{sec.\ air} + m_{hc}$$

$$\text{Outlet mass} = m_{kg} + m_{kd} + m_{hk}$$

3.1.3 Mass Balance of Cooler

$$\text{Inlet mass} = m_{cair} + m_{hk}$$

$$\text{Outlet mass} = m_{sair} + m_{tair} + m_{w\ air} + m_{cd}$$

3.2 Heat Balance of Cement Kiln

The energy balance for both preheater, rotary kiln and cooler is shown as the following:

3.2.1 Preheater Calciner

Accumulation rate = heat input - heat out put

$$\text{Heat input} = Q_1 + Q_2 + Q_{ra} + Q_4 + Q_{kgas} + Q_{dust} + Q_{Tair} + Q_{Pair}$$

$$\text{Heat output} = Q_7 + Q_6 + Q_{10} + Q_8 + Q_{hc} + Q_i$$

3.2.2 Rotary Kiln

Accumulation rate = heat input –heat out put

$$\text{Heat input} = Q_{1k} + Q_{2k} + Q_{\text{pair}} + Q_{\text{sair}} + Q_{\text{hc}}$$

$$\text{Heat output} = Q_6 + Q_{\text{kgas}} + Q_{\text{kdust}} + Q_{\text{hk}} + Q_l$$

3.2.2 Cooler

Accumulation rate = heat input –heat out put

$$\text{Heat input} = Q_{\text{hc}} + Q_5$$

$$\text{Heat out put} = Q_{\text{sair}} + Q_{\text{tair}} + Q_9 + Q_{11} + Q_l$$

The effect of different parameters on the fuel energy consumption in cement kiln plant can be determined by using the above modeling.

4. ENERGY CONSUMPTION IN CEMENT KILN PLANT

Table (2) provides the average energy consumption values by processes for cement kiln plant. In almost cases, the average energy consumption values is significantly higher than the best practice value, indicating that a strong potential for energy efficiency improvements in many cement kiln plants [26].

5. POTENTIAL FOR ENERGY SAVING THROUGH PROCESS OPTIMIZATION

Thermal energy costs in the cement industry represented in a considerable proportion of the total production cost (approximately 30% of the total production cost). So, great efforts have been made in the past to lower thermal energy consumption when producing cement. By build modern rotary kiln and shutting down old kilns, thermal energy consumption dropped from 4.5 GJ/t in 1960 to 3.0 GJ/t. The potential for energy saving in cement kiln plant:

- Improved on preheating in the clinker cooler.
- By improved burning technology and efficient use of waste heat of pre-heater exit gas and of the heat losses through the shell of the rotary kiln and of waste cooler leaving the great cooler.
- For the same fuel consumption, the specific fuel energy costs have been reduced still further by using cheap secondary fuels. Nowadays, about 20-50% of the total fuel energy required is covered by secondary fuel.

A typical the fuel energy requirement for efficient production may approach 3000 KJ/kg, of which 2000 KJ/kg is used in drying of the feed and for carrying out the chemical reactions while 1000 KJ/kg is consumed energy losses for the kiln system.

The energy losses from the kiln system has to be expended on wall heat losses from the rotary kiln and pre-heater system, sensible heat in the pre-heater exhaust gas, sensible heat in the waste exhaust from the cooler and sensible heat in the by pass gases if found.

So, measures for further saving of the fuel energy are concentrated on operational optimization of preheating system for the air (in clinker cooler) and kiln feed (in pre-heater system), and reducing the wall heat losses in rotary kiln, pre-heater and cooler and reducing the heat losses through by pass system [27].

5.1 Saving Fuel Energy Consumption by Kiln Optimization

Most of the cement clinker plant is two types of the plant:

- Rotary kiln with cyclone preheater, tertiary air duct equipped with grate cooler.
- Rotary kiln with cyclone preheater, tertiary air duct equipped with rotary cooler.

The average clinker outputs from the above types of the kiln line between 1000 and 6000 ton/day. The average value of energy consumption for different kiln plant is shown as follows:

It is noted that the range of bypass energy losses in Table 3 depends on the percentage of bypass gas ratio in the kiln system.

Table 4. shows the factors affecting on the fuel energy consumption of rotary kiln plant with cyclone preheater. It is shown that an increased of the exhaust gas energy losses from pre-heater should be equals approximately 0.7 to 0.9 of the fuel energy consumption. Wall heat losses in the pre-heater do not have such a severe effect on the fuel energy consumption and only required 0.2 to 0.8 of the fuel energy. On the other hand, a factor of a bout 1.2 of the fuel energy has to be applied for wall heat losses in the rotary kiln and in the lowest stage of the cyclone pre-heater. For the bypass heat losses from bypass system should be equals approximately with 0.46 of the fuel energy consumption.

However, for kiln plant with normal design data, the greatest influence on the fuel energy consumption is exerted by the cooler. An increase in cooler energy losses produces a relative increase of 1.5 times the amount in the fuel energy consumption in the kiln plant.

5.1.1 Clinker Cooler

Measures for improving the energy recovery one aimed by reducing the primary air into the rotary kiln burner as much as possible and increasing the quantity of an heated in the cooler as secondary and tertiary air. In addition to this, the installation of modern kiln inlet seals minimizing the induced false in which adversely effect on the performance of the kiln and on the energy recovery from the clinker cooler.

Heat transfer in the grate cooler can be improved further by increasing the bed thickness on the grate of the recuperation. This can be achieved by reducing the speed of the grate (stack/min).

The heat transfer can also be improved by the grate plate with horizontal air outlets and increased pressure drop in the grate plates.

The heat recovery in the grate cooler can be increased by utilization of the heat of the waste air. In this case, it can be appropriate to separate the recuperation zone of the cooler structurally from the cooling zone and optimizing each of them independently. The general aim is to achieve an efficiency of the cooler approximately more than 70.0% (27).

5.1.2 Rotary Kiln

The shell heat losses from the rotary kiln can represent a considerable proportion of the total energy loss, specially in kiln plants with small throughout the heat loss through the shell of rotating the kiln lies in the range of 200-600 KJ/kg of clinker depending on the productivity of the kiln and if the kiln system have with or without tertiary air duct. Normally, the heat loss decreases with the increase of the productivity e.g. the heat loss through the shell of rotary kiln for plant .having high productivity is lower than that having low productivity. Also, the heat loss through the shell of rotary kiln plant with tertiary air duct is lower than that without tertiary air duct [27].

The heat loss through the shell of the rotary kiln can be reduced and consequently reduce the fuel energy saving by shutting down small kiln with lower productivity and or building of modern pre-calciner kilns.

The heat loss through the shell of the rotary kiln in the modern cement kiln with pre-calciner can be reduced by decrease the fuel in the main burner as much as possible and increasing the fuel in the pre-calciner unit to be reduce the thermal load on the rotary kiln. Furthermore, the heat loss through the shell of the kiln can be reduce by selecting the type of refractory which having lower thermal conductivity (high insulation brick). It also can be decrease by achieve a uniformity and stable coating inside the rotary kiln. This can be achieved by adjusting of the flame shape inside the kiln and by selecting a raw materials which having stable coating tendency by selecting appropriate module like LSF, SM and AM of raw materials.

Reducing clinkering times and temperatures, this would indirectly help to reduce kiln shell losses above 900 °C, but in practice, the energy savings will be only a small fraction of the maximum possible savings estimated for eliminating completely those kiln shell losses. Thus, they are likely to be insignificant [28].

5.1.3 Cyclone Preheater

The type and operation of the pre-heater may also an important influence on the fuel energy consumption of a cement kiln plant with cyclone pre-heater. The thermal efficiency of the pre-heater depends on the number of the stages in the pre-heater and the capacity of the flow ratio of the gas and the kiln feed of materials. It is reduced by reducing the internal circulating dust in the pre-heater system. The mass flow of the materials in the pre-heater was larger than the mass flow of the feed materials, as a result of incomplete separation in the cyclones. The separation efficiency of the different stages lies in the range of 50 to 95%. In addition to this, the materials was not fully transferred from cyclone 3 to cyclone 4 through gas leaving the rotary kiln and some of it fall directly from cyclone 3 into the rotary kiln inlet without passing to cyclone 4. This caused the gas temperature in cyclone 4 to raise the unacceptably high level of 980 °C. By making the changes to the dip tubes and installing distribution boxes or by changing the angle of entry of the meal chute, it is possible to reduce circulating dust systems and meal by pass and therefore to improve the heat recovery in the pre-heater. This also reduces the tendency to form coating due to overheating of the meal chute of cyclone [27].

Reducing the volume of exhaust gases, typically, the kiln exhaust gases are well over 60 % nitrogen and this carries a lot of heat away with it into the atmosphere, especially because it is not industrially practical to cool these gases to below about 120 °C to avoid condensation of liquid water in the gas ducts or on the raw feed. If the fuel could be burned in pure oxygen, a much higher percentage of its heat would be available over the bottleneck temperature of 900 °C and much lower volume of exhaust gases would be created. Thus, the overall thermal efficiency could, in theory be improved [28].

5.1.4 Rotary Kiln Firing Systems

The minimizing excess air in rotary kiln without any formed of CO leads to improvement in the performance of the kiln and consequently leads to reduce the fuel energy consumption shorten and intensity the flame leads to reduce the fuel energy consumption. Furthermore, optimize kiln burner primary air is to consider as potential for decreasing of fuel energy consumption.

5.1.5 Lime Saturation Factor, Silica Moduli and Alumina Moduli of Kiln Feed

The specific fuel energy consumption can be decreasing by reducing lime saturation factor, LSF, silica moduli SM and alumina moduli, AM of kiln feed. In this situation it is noteworthy to mention that, these moduli can be adapting in cement kiln plant according to the quality required of produced cement [28].

5.1.6 Installing Modern Cement Kiln Plant

Another approach to improve energy efficiency is to shift to another cement production technology. In general, it can be said that the dry process is much more energy efficient than the wet process and the semi-wet some what more energy efficient than the semi-dry process. The processes are exchangeable to a large extent, but the applicability also depends on the raw material available.

5.1.7 Fuel Quality and Fuel Combustion Efficiency

By far the largest proportion of energy consumed in cement manufacture consists of fuel that is used to heat the kiln. Therefore, the greatest gain in reducing energy input may come from improved fuel efficiency. The fuel energy consumption can be decreasing by selecting the type of fuel which having higher calorific value and easy to combustion. In addition to that, by adjusting the flame shape, the fuel energy consumption in cement kiln plant will be improved.

5.1.8 Process Control

To use energy saving control schemes it is necessary to have reliable measured values available for the most important influencing variables and controlled variables. The external variables include the compositions and mass flows of the input materials and the exhaust gas mass flow after the pre-heater. Internal influencing variables are the mass and energy flows in the kiln system which even if the external influencing variables are constant can be subjected to significant fluctuations as a result of the linked heat and mass transfer. The energy flows of the rotary kiln inlet gas and of the hot clinker are particularly important in this context. Investigations have shown that the energy flow of the rotary kiln inlet gas can be subjected to considerable fluctuation due, in particular, to changing circulating processes between the rotary kiln and calciner. For constant external influencing variables the fluctuations act directly and exclusively on the degree of calcinations with which the kiln feed material from the calciner enter the kiln. In practice, if the external influencing variables are constant, the hot clinker energy flow only affects the secondary air energy flow. It is determined by the hot clinker mass flow and its temperature.

Any changes which occur to the influencing variables should be indicated at an early stage by informative signals and offset by appropriate control interventions so that process is able to run smoothly and save energy. In this situation use is made of so called virtual signals which are calculated from several measured variables. Examples of this, the fuel energy flow, the calcium carbonate mass flow, the level of pre-calcination of the kiln feed material after leaving the calciner and the secondary air energy flow. This requires simple and operationally reliable measuring equipment and powerful digital data processing systems for central evaluation and storage of the signals [6, 27].

5.2 Energy Saving by Utilization Waste Heat

In general 54% of the fuel energy consumption is required for the chemical reaction of the kiln feed to produce clinker. About 16% of the fuel energy consumption is consumed for drying of the raw materials in the raw mill. The total of this energy percent gas about 70% corresponded to the useful energy. The remaining of 30% of the energy is needed to cover energy losses, namely 9.6% for wall heat loss, 17.9% for the exhaust gas, 1.8% for the cold clinker and 1.2% for other losses. The overall efficiency of the kiln system can be improved by recovering some of the heat loss. The recovered heat energy can then be used for several purposes such as for electricity generation and

preparation of hot water. There are a few major heat loss sources that would be considered for heat recovery. These are heat losses by kiln exhaust gas, hot air from cooler stack and radiation from the kiln surface.

The amount of the heat in the waste gases can be utilized or energy recovery, depending on the flows, temperature of the waste gas and thermal capacity of the waste gas. In this section, it will be explain how can be utilizing the different waste heat in cement plant.

5.2.1 Bypass Gas from Kiln Inlet

In bypass system, a part of the kiln gas (depending on Cl_2 , SO_3 , Na_2O and K_2O) is extracted at the kiln inlet temperature 1100-1250 °C, then cooled by quenching air to the suitable temperature 350-450 °C, and then cooled in the water conditioning tower to 140-160 °C and then dedusting in electrostatic precipitators and then the clean gas is passing to the stack. In order to be utilizing of this waste heat, the extracted hot gas at the inlet kiln at 1100 to 1250 °C can be cooled only to 350 °C with air and then de-dusting in hot gas electrostatic precipitation and then the clean gas can be utilized in drying of raw materials, drying of slag. The heat in the bypass gases can also be used in waste heat boiler [29-30].

5.2.2 Exhaust Gas from Preheater

The pre-heater exhaust contains a certain amount of heat. The gas has a temperature of 350 °C and a dust content of about 20-30 ton/h depending on separation efficiency of cyclone pre-heater. If the raw materials moisture content is low, only using a part of this gas for drying. In the case of a waste heat boiler may be installed which utilizes the upper temperature range of the exit gas from 350 to 200 °C. A boiler in this case must be equipped with effective cleaning devices.

5.2.3 Utilized of Preheater Exit Gas for Drying Raw Material

On of the most effective methods of recovering waste heat in cement plant would be to preheat the raw materials before the clinking process. Directing gas streams into the raw materials just before the grinding mill generally does this. This would lead to a more efficient grinding of the raw materials in addition to increasing its temperature. However, in most plants, the fresh raw materials taken from the mill is not directly sent to the kiln, and therefore, the temperature increase of the raw materials does not generally make sense because it will be stored in silos for a while before entering the clinking process. On the other hands, some plants may have only kiln systems rather than grinding systems. In such cases, this may not be possible unless some additional modifications are made in the plant [30-31].

5.2.4 Exhaust Air from Cooler

With the grate cooler, a considerable amount of the exhaust air is obtained as a waste air. The temperature of this waste air lies in the range of 300 to 400 °C. For special utilization purposes, the exhaust air can be extracted from the cooler at two different points. In this case, the waste air can be divided into two zones inside the cooler, colder and hotter portions. The hottest portion can be used for heating of the thermal and or drying of slag. It can be also used for steam. A colder portion of air could be used for heating of water to produce steam to generated power by using turbine. It can be used for electricity generation as from directly driving a consumer machine [6, 29].

5.2.5 Conversion Four Stage to Five Stage Cyclone Preheater

By an addition of a one stage of cyclone, the exit gas temperature downstream of the pre-heater was 52 °C; the specific energy consumption was down by 45 kcal/kg clinker. By an addition of a one stage the retention time between gas and material will increase and consequently the pre-heater exit gas will decrease and decrease the specific fuel energy consumption [32].

CONCLUSION

Cement production is a highly energy intensive production processes. Important efforts are being made to continue for saving the energy for the cement industry.

Successful reduction of fuel consumption contributes to lower fuel cost, higher clinker production, lower electricity consumption and lower greenhouse gas emission.

Internationally, the cement industry is moving toward the use of alternative fuels such as tires, lubricants and oils. The use of alternative fuel can save cost and contribute to solution of the environmental problems.

REFERENCES

- [1] Lawrence CD., "The production of low energy cements", In: Hewlett PC, Editor. Lea's Chemistry of Cement and Concrete, 4th Ed., London : Arnold; **1998**, 421-470,
- [2] Kreft, W., Scheubel, B., and Schutte, R., "Clinker quality, power economy and environmental load", Influencing factors and adaptation of the burning process. Part 1. "Basic conditions", *Zement-Kalk-Gips*, **1987**, No.3, 127-133.
- [3] Rosemann H., Locher F.W., and Jeschar R., "Fuel energy consumption and operational behaviour of rotary cement kiln plants with precalcining" *Zement-Kalk-Gips*, **1987**, No.10, 489-498.
- [4] Richard Bolwerk, "Co-processing of waste and energy efficiency by cement plants", Council Government Munster, Parallel session. Energy Efficiency in Cement, Metal, Petrochemical Industry, **2004**, *Domplatz 1-4*, D 48128, Munster, 1-11.
- [5] Walter H. Duda, "Cement-Data-Book", Berlin, Bauverlag, **1985**.
- [6] Al Barrett, "How to reduce energy consumption", *World Cement*, January, 92-96, **2002**.
- [7] Sheinbaum C., and Ozawa L., "Energy use and CO₂ emissions for Mexico's cement industry", *Energy*, **1998**, Vol.23, No.9, 725-732.
- [8] Akgun-Fehmi, "Investigation of energy saving and NO_X reduction possibilities in rotary kiln", *International Journal of Energy Research*, **2003**, Vol.27, No.4, 455-466.
- [9] Shiban J., "Energy conservation", *World Cement*, November, **2002**.
- [10] Worrell E., Martin N., and Price L., "Potentials for energy efficiency improvements in the US cement industry", *Energy*, **2000**, Vol.25, No.12, 1189-1214.
- [11] Elkajaer, H. P., "Determining the heat consumption of a four stage cyclone preheater by applying a mathematical model". *Zement-Kalk-Gips*, **1980**, No. 2, 63 -68.
- [12] Gahzi, A., "Investigation of cement dry process with respect to fuel economy and product quality", Thesis submitted for the degree of Ph.D in Chemical Engineering, Cairo University, **1997**.
- [13] Gardiek, H. O and Rose Mann, H., "Fuel energy consumption and fuel energy apportionment in the pre-calcining processes", *Zement-Kalk-Gips*, **1981**, No.9, 435-444.
- [14] Peng Feri, "Thermal analysis of cyclone preheater system based on a mathematical model", *Zement-Kalk-Gips*, **1986**, No.3, 133 -135.
- [15] Kreft W., "Comparison of various bypass systems in clinker burning plants", *Zement-Kalk-Gips*, **1990**, No.1, 20 -25.
- [16] Hansen, V., "Clinker cooler", *World Cement Technology*, **1980**, 76-81..
- [17] Witsel, A. C, Renotte C, Remy M., "Contribution to dynamic modeling of a cement kiln", Abstract, lab., d. Automatique, Faculte Polytechnique de Mons. Belgium. Saas.uxb.ac.be/Benelux, **2005**.
- [18] Bao L., "Modeling, identification and control of cement kiln", Computer Aided Process Engineering Center, Department of Chemical Engineering, Technical University of Denmark, DK-2800 Lyngby, Denmark. [http://www. Capcc.kt.dtu.dk, documents/research./Poster EAM](http://www.Capcc.kt.dtu.dk, documents/research./Poster EAM) , **2004**.
- [19] Witsel A. C. and Renotte C, "Contribution to the control of a rotary cement kiln-A simulation study", Abstract, lab., d. Automatique, Faculte Polytechnique de Mons. Belgium. www.wfw.wtb.tue.nl/Benelux, **2004**.
- [20] Kaantee U, Zevenhoven R, Backman R., and Mikko H, "Cement manufacturing using alternative fuels and the advantages of process modeling", *Fuel Processing Technology* **2004**, 85, 293-301.
- [21] Kaantee U., Zevenhoven, R, Backman R, and Mikko H. , " Modeling a cement manufacturing process to study possible impacts of alternative fuels", Paper accepted for presentation at on Recycling and Waste Treatment in Minerals and Metal Processing, **2002**, June,16-20.
- [22] Radwan A. M, Abed El-hamid, A. S and Eissa A. H, " Dynamic modeling, simulation and control of cement kiln systems " *AUEJ*, **2005**, Vol.8. No.12, 637-698.
- [23] Shaleen K., Rangan B. and Uday G., "Energy balance and cogeneration for a cement plant", *Applied Thermal Engineering*, **2002**, 22, 485-494.
- [24] Tahsin E., Vedat A., "Energy auditing and recovery for dry type cement raotary kiln systems- A case study", *Energy Conversion and Management* **2005**, 46, 551-562.
- [25] Ernst W. and Christina G., "Energy efficiency, improvements opportunities for cement making- An Energy Sar, Guide for energy and plant managers, January. **2004**.
- [26] Jayant S., Lyme P., Stephan de Laru and David F., " Assessment of energy use and energy savings potential in selected industrials sectors in India" August, **2005**.
- [27] Scheuer A., and Ellerbrock, H.G, " Possibile ways of saving energy on cement production", *Zement -Kalk-Gips*, **1992**, No.5, 222 -230.
- [28] Ellis G., "Industrially interesting approaches to low CO₂ cements", *Cement & Concrete Research* **2004**, 34, 1489-1498.
- [29] Brend H., "Improving efficiency" *World Cement*, **2000**, September, 75-84.

[30]Cologue E., "Ways to achieve optimum utilization of waste gas heat in cement kiln plants with cyclone preheaters", *Zement- Kalk-Gips*, **1986**, No.4, 101-103.

[31]Clemente G., "A burning advantage", *World Cement*, **2000**, December, 67-71.

[32]Igawa T. and Hatano H., "Energy saving by conversion of a four- stage into a five- stage cyclone preheater", *Zement- Kalk-Gips*, **1987**, No.2, 41-42.

Nomenclature

| Symbol | Description | Symbol | Description |
|-------------------|-------------------------------------|-------------------|----------------------------------|
| m_c | Mass flow rate of fuel to preheater | m_{ck} | Clinker discharge |
| m_{ck} | Mass flow rate of fuel to kiln | $m_{p\text{air}}$ | Preheater exhaust |
| H_c | Net heating value | $m_{p\text{air}}$ | Primary air |
| Q_1 | Combustion of fuel to preheater | m_{tair} | Hot air from cooler to preheater |
| Q_2 | Sensible heat of fuel to preheater | m_{sair} | Hot air form cooler to kiln |
| m_{ra} | Raw materials | m_{wair} | Waste hot air from cooler |
| Q_3 | Heat by raw materials | m_{kd} | Dust from kiln to preheater |
| Q_4 | Organic in the kiln feed | m_{pd} | Dust from pre-heater |
| Q_{kg} | Heat by kiln gas | m_{ch} | Hot materials calciner to kiln |
| Q_{tair} | Heat by tertiary air | $m_{c\text{air}}$ | Cooling air enter to cooler |
| Q_{pair} | Primary air | | |
| Q_7 | Kiln exhaust gas | | |
| Q_6 | Heat of reaction | | |
| Q_8 | Moisture in raw material and fuel | | |
| Q_{10} | Heat loss by dust from preheater | | |
| Q_{kd} | Kiln dust from kiln to preheater | | |
| Q_{hc} | Hot calcined materials | | |
| Q_{hc} | Hot clinker | | |
| Q_{1k} | Combustion of fuel to kiln | | |
| Q_{2k} | Sensible heat of fuel to kiln | | |
| Q_{sair} | Heat for secondary air | | |
| Q_5 | Heat by cooling air | | |
| Q_9 | Hot air from cooler | | |
| Q_{11} | Clinker discharge | | |
| Q_l | Heat losses | | |