

DIFFERENTIAL METHODS IN INVERSE SCATTERING

Alfred M. Bruckstein *, *Bernard C. Levy* ** and *Thomas Kailath* *

* Information Systems Laboratory

STANFORD UNIVERSITY

Stanford, CA 94305

and

** Laboratory for Information and Decision Systems

MASSACHUSETTS INSTITUTE OF TECHNOLOGY

Cambridge, MA 02139

Information Systems Laboratory

Technical Report

June, 1983

*The work of these authors was supported in part by the U. S. Army Research Office, under Contract DAAG29-79-C-0215 and by the Joint Services Program, under Contract DAAG29-81-K-0057. **The work of this author was supported by the Air Force Office of Scientific Research, under Grant AFOSR-82-0135.

Report Documentation Page

Form Approved
OMB No. 0704-0188

Public reporting burden for the collection of information is estimated to average 1 hour per response, including the time for reviewing instructions, searching existing data sources, gathering and maintaining the data needed, and completing and reviewing the collection of information. Send comments regarding this burden estimate or any other aspect of this collection of information, including suggestions for reducing this burden, to Washington Headquarters Services, Directorate for Information Operations and Reports, 1215 Jefferson Davis Highway, Suite 1204, Arlington VA 22202-4302. Respondents should be aware that notwithstanding any other provision of law, no person shall be subject to a penalty for failing to comply with a collection of information if it does not display a currently valid OMB control number.

| | | | | | |
|---|------------------------------------|-------------------------------------|----------------------------|---|---------------------------------|
| 1. REPORT DATE AUG 1983 | | 2. REPORT TYPE | | 3. DATES COVERED 00-08-1983 to 00-08-1983 | |
| 4. TITLE AND SUBTITLE Differential Methods in Inverse Scattering | | | | 5a. CONTRACT NUMBER | |
| | | | | 5b. GRANT NUMBER | |
| | | | | 5c. PROGRAM ELEMENT NUMBER | |
| 6. AUTHOR(S) | | | | 5d. PROJECT NUMBER | |
| | | | | 5e. TASK NUMBER | |
| | | | | 5f. WORK UNIT NUMBER | |
| 7. PERFORMING ORGANIZATION NAME(S) AND ADDRESS(ES) Massachusetts Institute of Technology, Laboratory for Information and Decision Systems, 77 Massachusetts Avenue, Cambridge, MA, 02139-4307 | | | | 8. PERFORMING ORGANIZATION REPORT NUMBER | |
| 9. SPONSORING/MONITORING AGENCY NAME(S) AND ADDRESS(ES) | | | | 10. SPONSOR/MONITOR'S ACRONYM(S) | |
| | | | | 11. SPONSOR/MONITOR'S REPORT NUMBER(S) | |
| 12. DISTRIBUTION/AVAILABILITY STATEMENT Approved for public release; distribution unlimited | | | | | |
| 13. SUPPLEMENTARY NOTES | | | | | |
| 14. ABSTRACT | | | | | |
| 15. SUBJECT TERMS | | | | | |
| 16. SECURITY CLASSIFICATION OF: | | | 17. LIMITATION OF ABSTRACT | 18. NUMBER OF PAGES 47 | 19a. NAME OF RESPONSIBLE PERSON |
| a. REPORT unclassified | b. ABSTRACT unclassified | c. THIS PAGE unclassified | | | |

ABSTRACT

This paper presents a new set of differential methods for solving the inverse scattering problem associated to the propagation of waves in an inhomogeneous medium. By writing the medium equations in the form of a two-component system describing the interaction of rightward and leftward propagating waves, the causality of the propagation phenomena is exploited in order to identify the medium layer by layer. The recursive procedure that we obtain constitutes a continuous version of an algorithm first derived by Schur in order to test for the boundedness of functions analytic inside the unit circle. It recovers the local reflection coefficient function of the medium. Using similar ideas, some other differential methods are also derived to reconstruct alternative parametrizations of the layered medium in terms of the local impedance or of the potential function. One of these methods is known in the literature as the method of characteristics.

The differential inverse scattering methods turn out to be very efficient since, in some sense, they let the medium perform the inversion by itself and thus fully exploit its structure. They provide an alternative to classical methods based on integral equations, which, in order to exploit the structure of the problem, must ultimately resort to differential equations of the same type.

1. INTRODUCTION

The inverse problem for the one-dimensional Schrodinger equation and for two-component scattering systems has received a large amount of attention over the years. This interest is motivated by the numerous applications of such problems existing in fields as varied as geophysics, transmission-line analysis, filter design, voice synthesis and quantum physics [1]-[10].

The first complete solution of the inverse scattering problem was obtained by Gelfand and Levitan [11], in the context of reconstructing a second order differential operator from its spectral function. Subsequently, several alternative solutions were proposed by Marchenko [12], Krein [13], Kay and Moses [14] and Faddeev [8],[15]. Other inversion procedures were derived by Gopinath and Sondhi [5],[6] and by Zakharov and Shabat [16],[17] for systems described respectively by transmission-line type equations and by two-component scattering models.

Since all the inverse scattering procedures mentioned above were formulated in terms of integral equations it was widely accepted in the scientific community that inverse problems require the solution of such equations. However, independently of the work of mathematicians and physicists, geophysicists such as Goupillaud, Claerbout and Robinson developed approaches which more directly exploit the physical properties of layered media in which waves propagate. Their solutions, sometimes referred to as dynamic deconvolution methods [2],[4], reconstruct the medium layer by layer, in a recursive manner. However this work was formulated in terms of a discretized layered earth model and was therefore not recognized as providing a solution to the general inverse

scattering problem. In fact, when dealing with continuously varying media geophysicists went back to using integral equations based approaches [1],[3],[18].

More recently, Deift and Trubowitz [19] proposed a potential reconstruction method based on a trace formula which calls for the propagation of an ordinary differential equation and which does not fit the classical inverse scattering framework.

The objective of this paper is to give a comprehensive account of differential inverse scattering methods. This is done by first deriving an infinitesimal layer peeling procedure which can be viewed as a continuous version of the dynamic deconvolution algorithm. This algorithm is in fact a continuous form of a method used by Schur to test for the boundedness of functions analytic inside the unit circle [20],[21]. The identification of recursive layer extraction methods with the Schur algorithm was first made by Dewilde and his coworkers [22],[23]. The method of characteristics (see e.g. Symes [24]), used by Santosa and Schwetlick [25] and by Sondhi and Resnick [26] for solving acoustical inverse problems, can also be interpreted from this point of view. The relation between the differential inverse scattering methods that we propose and the classical integral-equations-based approaches is then discussed. It is shown that by exploiting the structure of these integral equations, one can obtain a system of differential equations which solves the inverse problem. The differential equations have the same dynamics as the Schur recursions but require certain boundary values that have to be successively computed by using the integral equations. In fact these recursions are of the same type as the Krein-Levinson equations for factoring the resolvent of a Toeplitz operator [27],[28].

The paper is organized as follows. Several physical models of a scattering medium are presented in Section 1. These provide various equivalent parametr-

izations of the medium and give rise to different formulations of inverse scattering problems. The continuous layer-peeling algorithm and the associated Schur recursions for reconstructing the reflectivity function parametrization of the medium are derived in Section 3. They are then used in Section 4 to obtain other differential methods that reconstruct either the local impedance or the Schrodinger potential medium parametrizations. Section 5 relates these differential methods to the integral equations approaches and describes the Krein-Levinson type differential solution of the inverse problem. In Section 6 the results of the earlier sections are extended to some cases when the scattering medium is not lossless and Section 7 concludes with observations on possible extensions of these results.

2. Physical Models of Scattering Media

The inverse scattering methods that we discuss in this paper concern several classes of physical models which correspond to equivalent descriptions of a lossless scattering medium. They arise in the study of transmission-lines and of vibrating strings, in the analysis of layered acoustic media and of the vocal tract and in the description of particle scattering in quantum physics [1]-[9],[29],[30].

The first model that we consider is described by the symmetrized *telegrapher's equations*

$$\frac{\partial}{\partial x} \begin{bmatrix} v(x,t) \\ i(x,t) \end{bmatrix} = \begin{bmatrix} 0 & -Z(x) \frac{\partial}{\partial t} \\ -Z(x)^{-1} \frac{\partial}{\partial t} & 0 \end{bmatrix} \begin{bmatrix} v(x,t) \\ i(x,t) \end{bmatrix} \quad (2.1)$$

which may be viewed as obtained from the usual transmission-line equations by assuming that the inductance per unit length equals the inverse of the capacitance. $Z(x)$ in the above equation corresponds to the *local impedance* for a transmission-line or to the *area function* of the vocal tract model [6],[25],[26]. Since in equation (2.1) the "voltage" and "current" variables are expressed in different units, we also consider the normalized quantities

$$V(x,t) = v(x,t)Z(x)^{-1/2} \quad \text{and} \quad I(x,t) = i(x,t)Z(x)^{1/2} \quad (2.2)$$

which now have the same dimension. In terms of these normalized variables (2.1) becomes

$$\frac{\partial}{\partial x} \begin{bmatrix} V(x,t) \\ I(x,t) \end{bmatrix} = \begin{bmatrix} -k(x) & -\frac{\partial}{\partial t} \\ -\frac{\partial}{\partial t} & k(x) \end{bmatrix} \begin{bmatrix} V(x,t) \\ I(x,t) \end{bmatrix} \quad (2.3)$$

where $k(x)$ is the *local reflection coefficient* (also called the *reflectivity function*) given by

$$k(x) = Z(x)^{-1/2} \frac{d}{dx} Z(x)^{1/2} = \frac{1}{2} \frac{d}{dx} \ln Z(x) \quad (2.4)$$

Note that, as a direct consequence of this normalization, we have

$$\frac{v(x,t)}{i(x,t)} = \frac{V(x,t)}{I(x,t)} Z(x) \quad (2.5)$$

From the system (2.3) we can obtain directly the second order *wave equations*

$$\begin{cases} \left(\frac{\partial^2}{\partial x^2} - \frac{\partial^2}{\partial t^2} \right) V(x,t) - P(x) V(x,t) = 0 \\ \left(\frac{\partial^2}{\partial x^2} - \frac{\partial^2}{\partial t^2} \right) I(x,t) - Q(x) I(x,t) = 0 \end{cases} \quad (2.6)$$

where the *potentials* are given by

$$\begin{aligned} P(x) &= -\frac{d}{dx} k(x) + k(x)^2 = Z(x)^{1/2} \frac{d^2}{dx^2} Z(x)^{-1/2} \\ Q(x) &= \frac{d}{dx} k(x) + k(x)^2 = Z(x)^{-1/2} \frac{d^2}{dx^2} Z(x)^{1/2} \end{aligned} \quad (2.7)$$

In the transform domain the equations (2.6) take the form of Schrodinger equations, which justifies calling $P(x)$ and $Q(x)$ potentials. From (2.3) we can also obtain a model where the variables of interest are right and left propagating waves defined as

$$W_R(x,t) = \frac{V(x,t) + I(x,t)}{2} \quad \text{and} \quad W_L(x,t) = \frac{V(x,t) - I(x,t)}{2} \quad (2.8)$$

The evolution of the *wave variables* is given by

$$\frac{\partial}{\partial x} \begin{bmatrix} W_R(x,t) \\ W_L(x,t) \end{bmatrix} = \begin{bmatrix} -\frac{\partial}{\partial t} & -k(x) \\ -k(x) & \frac{\partial}{\partial t} \end{bmatrix} \begin{bmatrix} W_R(x,t) \\ W_L(x,t) \end{bmatrix} \quad (2.9)$$

To interpret this equation, note that when the impedance is constant over a certain section of the medium we shall have $k(x) = 0$ and therefore $W_R(x,t) = W_R(t-x)$ and $W_L(x,t) = W_L(t+x)$, corresponding to non-interacting right and left propagating waves. The intensity of local interaction between the waves propagating in opposite directions is quantified by $k(x)$, which justifies calling it the local reflection coefficient. A simple discretization of (2.9) gives the lattice model shown in Fig. 1. Such discrete lattice structures appear in a large number of applications, such as the linear prediction algorithms for speech signals [31], the layered-earth models of Goupillaud [2],[3], and digital filter synthesis [22]. The model in Fig. 1 is in fact crucial to the intuitive understanding of the inverse scattering techniques that we shall derive below.

By performing the space transformation

$$y(x) = \int_0^x Z(\xi) d\xi \quad (2.10)$$

on the telegrapher's equation we obtain the *string equation*

$$\frac{\partial^2}{\partial y^2} v(y,t) = \mu(y) \frac{\partial^2}{\partial t^2} v(y,t) \quad (2.11)$$

where $\mu(y)$ is the *mass density of the string* and is given by

$$\mu(y) = Z^{-2}[x(y)] \quad (2.12)$$

where $x(y)$ is the inverse transformation corresponding to (2.10). This model arises in connection with the use of inverse scattering methods in linear estimation theory [29]. By using the alternate space transformation

$$y'(x) = \int_0^x Z(\xi)^{-1} d\xi \quad (2.13)$$

we also obtain the *conjugate string equation*

$$\frac{\partial^2}{\partial y^2} i(y', t) = \mu'(y') \frac{\partial^2}{\partial t^2} i(y', t) \quad (2.14)$$

with

$$\mu'(y') = Z^2[x(y')] \quad (2.15)$$

Note that $\mu[y(x)] \mu'[y'(x)] = 1$, which explains referring to (2.11) and (2.14) as conjugate equations.

The four models of a scattering medium that we use in the sequel are thus the telegrapher's equations (2.1) parametrized by $Z(x)$, the Schrodinger equations (2.6) parametrized by $P(x)$ and $Q(x)$, the two-component wave system (2.9) specified by $k(x)$ and the string equations (2.11) and (2.14) parametrized by $\mu(y)$ and $\mu'(y')$ respectively. The objective of the inverse scattering problem that we address below is to reconstruct any of the above parametrizations from some given scattering data. The scattering data is obtained by probing the medium in order to determine its impulse or frequency response at one of the boundaries. The probing signals and the medium response are assumed to be measured perfectly, i.e. *the scattering data will be considered noise free*. Also note that, since $k(x)$ and $P(x)$ and $Q(x)$ are expressed in terms of the first and second derivatives of the impedance function, the different inversion methods will require various degrees of smoothness for $Z(x)$. When discussing the various cases we therefore assume that the $Z(x)$ function is as smooth as necessary for the expressions involved to be well-defined; fairly standard limiting procedures can often be used to relax these restrictions.

The inverse scattering problem associated with the Schrodinger equation of quantum physics is complicated by the possible existence of bound states. A

consequence of the assumed transmission-line model (2.1) is that energy cannot be trapped in the medium thereby ruling out the possibility of bound states [1],[17].

3. Continuous Parameter Schur Recursions

The basic differential inverse scattering method that we discuss in this paper relies on the wave picture associated with equation (2.9), a discrete approximation of which is depicted in Fig. 1.

3.1. The scattering data

The necessary data for the reconstruction of the scattering medium parameters may be obtained in two possible ways.

In the first case the medium is assumed to be quiescent at $t=0$ and it is probed by a known rightward propagating waveform incident on the medium after $t=0$. This waveform $W_R(0,t)$ will in general be an impulse followed (in time) by a piecewise continuous function, but we also discuss the case when no leading impulse is present. The measured data is the leftward propagating wave, as it is recorded at $x=0$, $W_L(0,t)$. It can be viewed as obtained by convolving the impulse response $R(t)$, of the scattering medium, with the probing wave $W_R(0,t)$. Since the ultimate objective is to measure the impulse response of the medium, the nature of the probing wave is not important provided it contains enough energy at all frequencies. Note, indeed, that as long as $W_R(0,t)$ is given and $W_L(0,t)$ is measured perfectly, we can always obtain the impulse response by performing a deconvolution.

Another way of gathering scattering data is to perform a measurement of its frequency response $\hat{R}(\omega)$ by sending into the medium sinusoidal waveforms at various frequencies and measuring the magnitude and phase-shift of the returning sinusoidal wave. This is clearly equivalent to the time-domain meas-

urements described above, since $\hat{R}(\omega)$ is the Fourier transform of $R(t)$.

From a practical point of view we cannot always directly generate the waveform $W_R(0,t)$ and measure $W_L(0,t)$. However we usually do have access to the physical variables $v(0,t)$ and $i(0,t)$, and by obtaining the medium response in terms of these variables we can reconstruct the corresponding $W_R(0,t)$ and $W_L(0,t)$ by using (2.8). (In the sequel we assume that $Z(0) = 1$.) The nature of the measurements (impulse or frequency response) clearly depends on the physical apparatus that is available. In the geophysical context, approximate impulse responses are obtained by using explosive sources (dynamite, air-guns) and frequency response data can be generated by using wide-band acoustic sources [2],[32]

3.2. The layer peeling procedure

Suppose that the incoming wave $W_R(0,t)$ contains a leading impulse. This impulse will propagate through the medium and, since the medium is causal, it is not hard to recognize by examining Fig. 1. that the waves $W_R(x,t)$ and $W_L(x,t)$ must have the form

$$\begin{cases} W_R(x,t) = \delta(t-x) + w_R(x,t) u(t-x) \\ W_L(x,t) = w_L(x,t) u(t-x) \end{cases} \quad (3.1)$$

where $w_R(x,t)$ and $w_L(x,t)$ are some piecewise continuous functions, $\delta(\cdot)$ denotes the Dirac distribution, and $u(\cdot)$ is the unit step function, i.e.,

$$u(t) = \begin{cases} 1 & \text{for } t \geq 0 \\ 0 & \text{for } t < 0 \end{cases} \quad (3.2)$$

The causal nature of $W_R(x,t)$ and $W_L(x,t)$, i.e. that they are zero for $t < x$, is a direct consequence of the fact that the medium was at rest at $t=0$ since the impulse requires an amount of time equal to x to reach the depth x in the

medium. Note that we assumed that the perturbation in the medium originated from its left end alone. By substituting (3.1) into the propagating equations (2.9) and equating the coefficients of $\delta(t-x)$ on both sides, we find that

$$w_L(x, x+) = \frac{1}{2}k(x) \quad \text{and} \quad \frac{d}{dx}w_R(x, x+) = -\frac{1}{2}k(x)^2 \quad (3.3)$$

This argument is an application of the classical method of *propagation of singularities* (see. e.g. [33]). Now, noting that the expression (3.1) for $W_R(x, t)$ and $W_L(x, t)$ implies that

$$\begin{aligned} V(x, t) &= \delta(t-x) + \Psi(x, t) u(t-x) \\ I(x, t) &= \delta(t-x) + \Phi(x, t) u(t-x) \end{aligned} \quad (3.4)$$

where

$$\Psi(x, t) = w_R(x, t) + w_L(x, t) \quad \text{and} \quad \Phi(x, t) = w_R(x, t) - w_L(x, t) \quad (3.5)$$

we conclude from (3.3) and (2.7) that the potentials are given by

$$\begin{aligned} P(x) &= -2 \frac{d}{dx}\Psi(x, x+) \\ Q(x) &= -2 \frac{d}{dx}\Phi(x, x+) \end{aligned} \quad (3.6)$$

The above results show that the local reflection coefficient sequence $k(x)$ can be reconstructed directly from the reflected waves at depth x in the scattering medium. However we have assumed that only the reflected wave at $x=0$ is measured; the waves at depth $x > 0$ will be constructed by a recursive procedure. Thus let us assume that the waves at point x have already been computed; then $k(x)$ can be readily identified as $w_L(x, x+)$ using (3.3) and substituting this value into the propagation equations (2.9), we can compute the waves at depth $x+\Delta$. Therefore, starting at $x=0$, the resulting recursive algorithm can successively identify the local reflection coefficient for increasing values of x . This recursive inverse scattering process may also be viewed as a

layer-peeling algorithm, where at every step one infinitesimal layer of the scattering medium is identified and effectively removed. The right and left propagating waves inside the medium are recursively generated and can be regarded at each step as a new set of scattering data for the remaining extent of the medium. For a lossless and discrete layered medium this algorithm is known in geophysics as a *dynamic deconvolution* process [4] and it is called the *downward continuation* method by Bube and Burridge [34]. Dewilde et al. [22],[23], noted that this algorithm is equivalent to the Darlington synthesis procedure for scattering functions and pointed out its similarity to a result of Schur (1917) that will be discussed in the next section. In the context of fast algorithms for linear estimation and operator factorization theory these recursions are sometimes referred to as the *fast Cholesky* recursions. The operator factorization identity associated to these recursions is discussed in [28].

To implement the layer peeling method we can use the following numerical scheme which was also derived in a slightly different form by Dewilde, Fokkema and Widya [23]. Denote

$$a_R(x,t) = w_R(x,t+x) \quad \text{and} \quad a_L(x,t) = w_L(x,t+x) \quad (3.7)$$

Then, integrating the evolution equations (2.9), we obtain, after some calculation, the following system of equations

$$\begin{cases} a_R(x,t) = w_R(0,t) - \int_0^x k(\xi) a_L(\xi,t) d\xi \\ a_L(x,t) = w_L(0,t+2x) - \int_0^x k(\xi) a_R(\xi,t+2x-2\xi) d\xi \end{cases} \quad (3.8)$$

together with the formula giving the reflection coefficient

$$k(x) = 2a_L(x,0) = 2 \left[w_L(0,2x) - \int_0^x k(\xi) a_R(\xi, 2x - 2\xi) d\xi \right] \quad (3.9)$$

By recursively integrating (3.8)-(3.9) along successive antidiagonals in the (x,t) plane, as depicted in Fig. 2., we can obtain the local reflection coefficients $k(x)$, for increasing values of x . Note also that we only need to know the probing and reflected waves $W_P(0,t)$ and $W_L(0,t)$ over the time span $[0,2x]$ in order to recover the transmission line parametrization up to depth x .

From a computational point of view, if we assume that the part of the medium of interest has total length L , and if we use a difference scheme with step-size L/N in the propagation of the layer peeling algorithm, (3.8)-(3.9), the total number of operations required to reconstruct the local reflection coefficient parametrization is $O(N^2)$. These algorithms are therefore very efficient, when compared to the direct deconvolution methods which do not exploit the physical structure of the medium.

3.3. The Schur recursions

By taking the Fourier transform of the waves $W_R(x,t)$ and $W_L(x,t)$ the propagation equations (2.9) become

$$\frac{\partial}{\partial x} \begin{bmatrix} \hat{W}_R(x,\omega) \\ \hat{W}_L(x,\omega) \end{bmatrix} = \begin{bmatrix} -j\omega & -k(x) \\ -k(x) & j\omega \end{bmatrix} \begin{bmatrix} \hat{W}_R(x,t) \\ \hat{W}_L(x,t) \end{bmatrix} \quad (3.10)$$

and the frequency response, or *reflection coefficient function* of the section of scattering medium over $[x,\infty)$ is given by the ratio

$$\hat{R}(x,\omega) = \frac{\hat{W}_L(x,\omega)}{\hat{W}_R(x,\omega)} \quad (3.11)$$

Clearly

$$\hat{R}(0, \omega) = \hat{R}(\omega) \quad (3.12)$$

is provided by the given scattering data. Using these definitions the layer-peeling algorithm described above can be recast as a recursive procedure for computing the sequence of reflection coefficient functions $\hat{R}(x, \omega)$ for increasing values of x . Since $\hat{R}(x, \omega)$ is the ratio of variables with a linear evolution given by (3.10), it will not be surprising to find, after some algebra, that it satisfies the Riccati equation

$$\frac{d}{dx} \hat{R}(x, \omega) = 2j\omega \hat{R}(x, \omega) + k(x) [\hat{R}(x, \omega)^2 - 1] \quad (3.13)$$

It is not clear how this can help, since $k(\cdot)$ is unknown, but recalling the identity (3.3) for $k(x)$ and the form (3.1) for the waves at x , we find by using the initial value theorem for unilateral transforms that

$$k(x) = 2\omega_L(x, x+) = \lim_{\omega \rightarrow \infty} 2j\omega \hat{R}(x, \omega) \quad (3.14)$$

By using (3.14) the equation (3.13) can now be propagated autonomously. In terms of the causal impulse response $R(x, t)$ corresponding to the reflection function $\hat{R}(x, \omega)$, the equation (3.14) simply states that

$$k(x) = 2R(x, 0+) \quad (3.15)$$

The Riccati equation (3.13) for the reflection function is fairly well-known in radiative transfer and transmission-line theory, and is a direct consequence of the rules of cascading infinitesimal scattering layers [35]. More details about the evolution of the medium representation under successive compositions of infinitesimal scattering layers will be given in Section 5.

In the context of the inverse problem of geophysics the Riccati equation (3.13) was also obtained by Gjevik et al. [36]. However, they did not notice the relation (3.14) which can be used to propagate the Riccati equation recursively, starting from the scattering data $\hat{R}(0, \omega) = \hat{R}(\omega)$. They proposed an iterative

rather than recursive procedure to compute the $k(x)$ function. We should note at this point that the computational issues associated with solving (3.13),(3.14) have not been studied and deserve further investigation.

The equations (3.13) and (3.14) constitute the continuous version of a procedure derived by Schur, in 1917 [20],[21], for testing boundedness of an analytic function outside the unit circle of the complex plane. Given a power series in z^{-1} , $S(z)$, Schur proved that $|S(z)| < 1$ on the unit circle if and only if the sequence of coefficients k_n generated by the recursion

$$S_{n+1} = \frac{1}{z} \frac{S_n(z) - k_n}{1 - k_n S_n(z)} \quad \text{with} \quad k_n = \lim_{z \rightarrow \infty} S_n(z) \quad (3.16)$$

are such that $|k_n| \leq 1$. The discrete parameter recursion (3.16) is in fact a discretized form of the Riccati recursion (3.13) and can be obtained from it by using a backwards difference scheme.

The Schur algorithm (3.16) may be interpreted as testing for the existence of a discrete (i.e. with piecewise constant impedance) transmission-line having $S(z)$ for the left reflection coefficient function. Similarly, the continuous version of this algorithm may be considered as testing for the existence of a lossless transmission-line which synthesizes the given scattering function $\hat{R}(\omega)$. A condition for the existence of such a transmission-line is that the reconstructed local impedance function $Z(x)$, appearing in the model (2.1), should be strictly positive and bounded. Since, from (2.4)

$$Z(x) = Z(0) \exp\left\{\int_0^x k(\xi) d\xi\right\} \quad (3.17)$$

this implies that we need to have $\left|\int_0^x k(\xi) d\xi\right| < \infty$ for all x . In this case $\hat{R}(\omega)$ is bounded by 1 on the real axis. We note that if a transmission-line is lossless, its left reflection function $\hat{R}(\omega)$ must be bounded by one on the real axis as a result

of energy conservation [5],[7],[9],[15]. The above result is therefore the continuous equivalent of the boundedness test devised by Schur.

4. Other Differential Inversion Methods

In the previous section our analysis concentrated on the two-component system of wave equations (2.9), and in this framework we have shown how to reconstruct the local reflection coefficient function $k(\cdot)$. By recalling the identities (2.7) and (3.17), the potentials $P(\cdot)$ and $Q(\cdot)$, and the impedance $Z(\cdot)$ may also be obtained. However, since $k(\cdot)$ is expressed as a function of the first derivative of the local impedance function, the reconstruction method that we have described above requires the differentiability of $Z(\cdot)$. When the local impedance function is only piecewise differentiable the Schur algorithm can be modified to take the discontinuities into account. However a more direct method is to use the *method of characteristics*, which can be described as follows.

4.1. The method of characteristics

Assume that the probing wave $W_R(x,t)$ does *not* contain a leading impulse and is a piecewise continuous function starting at $t=0$. Then, by causality, $W_R(x,t)$ and $W_L(x,t)$ must have the form

$$\begin{cases} W_R(x,t) = w_R(x,t) u(t-x) \\ W_L(x,t) = w_L(x,t) u(t-x) \end{cases} \quad (4.1)$$

Substituting these expressions into (2.9) we find that

$$w_L(x,x+) = 0 \quad (4.2)$$

which implies that

$$V(x, x+) = I(x, x+) \quad (4.3)$$

Recalling the identity (2.5) this shows that we have

$$\frac{v(x, x+)}{i(x, x+)} = Z(x) \quad (4.4)$$

Therefore, to reconstruct the impedance function, $Z(\cdot)$, we only need to measure the voltage and current variables $v(0, t)$ and $i(0, t)$ at the left boundary of the scattering medium and to propagate $v(x, t)$ and $i(x, t)$ by using (4.4) and (2.1). Note that the knowledge of the voltage and current variables at depth x enables us to compute the impedance $Z(x)$, which in turn can be used to obtain the functions $v(x+\Delta, t)$ and $i(x+\Delta, t)$. In this manner the impedance $Z(x)$ is computed recursively, starting from $x=0$, and this procedure is known in the literature as the method of characteristics [24]-[26].

The above inverse scattering procedure can be interpreted in terms of the layer-peeling technique of section 3.2 by considering the discretized version of (2.1) shown in Fig. 3. This figure indicates that the current and voltage variables at point $(n+1)\Delta$, where Δ is the discretization step-size, are obtained from the corresponding variables at depth $n\Delta$ by cascading a scattering layer described by the matrix

$$\Sigma_n = \begin{bmatrix} Z(n\Delta)^{1/2} & 1 \\ Z(n\Delta) & 2Z(n\Delta)^{1/2} \end{bmatrix} \quad (4.5)$$

with time delays and the inverse of the first scattering layer. This result can be obtained by noting that

$$\begin{bmatrix} W_R(n\Delta, t) \\ W_L(n\Delta, t) \end{bmatrix} = \Theta_n \begin{bmatrix} i(n\Delta, t) \\ v(n\Delta, t) \end{bmatrix} \quad (4.6)$$

where

$$\Theta_n = \frac{1}{2} \begin{bmatrix} Z(n\Delta)^{1/2} & Z(n\Delta)^{-1/2} \\ -Z(n\Delta)^{1/2} & Z(n\Delta)^{-1/2} \end{bmatrix} = [P_+\Sigma_n + P_-][P_-\Sigma_n + P_+]^{-1} \quad (4.7)$$

is the chain scattering or transmission matrix corresponding to the scattering representation Σ_n [37]. The projection matrices P_+ and P_- appearing in the above formula are defined as follows

$$P_+ = \begin{bmatrix} 1 & 0 \\ 0 & 0 \end{bmatrix} \quad P_- = \begin{bmatrix} 0 & 0 \\ 0 & 1 \end{bmatrix} \quad (4.8)$$

The method of characteristics exploits the delay structure as displayed in Fig. 3 and the fact that the left reflection coefficient (i.e. the 21 entry) of the matrix Σ_n is the local impedance $Z(n\Delta)$. Since both Σ_n and its inverse are entirely parametrized by the local impedance, the scattering layers associated to these matrices can be easily "peeled off" (i.e. their effect may be accounted for) as soon as $Z(n\Delta)$ has been computed.

The identity (4.4) shows that the reconstruction procedure described above can also be used to obtain the mass densities $\mu(\cdot)$ and $\mu'(\cdot)$, appearing in the string equations (2.11) and (2.14). This is done by substituting

$$\mu(y) = \left[\frac{i(y, y+)}{v(y, y+)} \right]^2 \quad (4.9)$$

and

$$\mu'(y') = \left[\frac{v(y', y'+)}{i(y', y'+)} \right]^2 \quad (4.10)$$

into the equations

$$\frac{\partial}{\partial y} \begin{bmatrix} v(y, t) \\ i(y, t) \end{bmatrix} = \begin{bmatrix} 0 & -\frac{\partial}{\partial t} \\ -\mu(y) \frac{\partial}{\partial t} & 0 \end{bmatrix} \begin{bmatrix} v(y, t) \\ i(y, t) \end{bmatrix} \quad (4.11)$$

and

$$\frac{\partial}{\partial y'} \begin{bmatrix} v(x, y') \\ i(y', t) \end{bmatrix} = \begin{bmatrix} 0 & -\mu(y') \frac{\partial}{\partial t} \\ -\frac{\partial}{\partial t} & 0 \end{bmatrix} \begin{bmatrix} v(y', t) \\ i(y', t) \end{bmatrix} \quad (4.12)$$

that describe the strings (2.11) and (2.14).

4.2. Direct recovery of the potential

Similarly, there also exists a procedure for computing the potentials $P(\cdot)$ and $Q(\cdot)$ directly, without first reconstructing the reflection coefficient function $k(\cdot)$. To do so let

$$\begin{aligned} F(x, t) &= \left(\frac{\partial}{\partial x} + \frac{\partial}{\partial t} \right) V(x, t) \\ G(x, t) &= \left(\frac{\partial}{\partial x} - \frac{\partial}{\partial t} \right) I(x, t) \end{aligned} \quad (4.13)$$

Then the Schrodinger equations (2.6) can be rewritten in the form of asymmetric two-component differential systems, given by

$$\frac{\partial}{\partial x} \begin{bmatrix} V(x, t) \\ F(x, t) \end{bmatrix} = \begin{bmatrix} -\frac{\partial}{\partial t} & 1 \\ P(x) & \frac{\partial}{\partial t} \end{bmatrix} \begin{bmatrix} V(x, t) \\ F(x, t) \end{bmatrix} \quad (4.14)$$

and

$$\frac{\partial}{\partial x} \begin{bmatrix} I(x, t) \\ G(x, t) \end{bmatrix} = \begin{bmatrix} -\frac{\partial}{\partial t} & 1 \\ Q(x) & \frac{\partial}{\partial t} \end{bmatrix} \begin{bmatrix} I(x, t) \\ G(x, t) \end{bmatrix} \quad (4.15)$$

The layer-peeling technique introduced in Section 3 can again be used to recover the potentials $P(\cdot)$ and $Q(\cdot)$ directly, by noting that

$$\begin{aligned} P(x) &= -2F(x, x+) \\ Q(x) &= -2G(x, x+) \end{aligned} \quad (4.16)$$

Consequently, if we propagate the variables $\{V(x, t), F(x, t)\}$ or $\{I(x, t), G(x, t)\}$ by using (4.16) and the propagation equations (4.14)-(4.15), the potentials $P(\cdot)$ and

$Q(\cdot)$ can be recovered directly from the scattering data.

To obtain the initial conditions for the systems (4.14) and (4.15) we assume that the scattering data is $W_P(0,t) = \delta(t)$ and $W_R(0,t) = R(t)u(t)$. Then, by using equation (2.3) and the fact that $k(0) = 2R(0+)$, we find that

$$\begin{cases} V(0,t) = \delta(t) + R(t)u(t) \\ F(0,t) = -2\left[-\frac{d}{dt}R(t) + R(0+)R(t)\right]u(t) \end{cases} \quad (4.17)$$

and

$$\begin{cases} I(0,t) = \delta(t) - R(t)u(t) \\ G(0,t) = -2\left[\frac{d}{dt}R(t) + R(0+)R(t)\right]u(t) \end{cases} \quad (4.18)$$

Whereas in Section 3 the potential was reconstructed by using the original scattering data and then differentiating the reflectivity function, the method that we propose here first differentiates the scattering data and then reconstructs the potential directly.

The layer-peeling algorithm for the systems (4.14),(4.15) can be interpreted as successively truncating the potentials $P(\cdot)$ and $Q(\cdot)$ in such a way that the new potentials

$$\begin{aligned} P(z,x) &= P(z)u(z-x) \\ Q(z,x) &= Q(z)u(z-x) \end{aligned} \quad (4.19)$$

correspond to the part of the original scattering medium located to the right of x . In this interpretation it is assumed that the part of the scattering medium on the left of x that was removed by the layer-peeling algorithm has been replaced by free-space (i.e. $k(z) = 0$ for $z < x$). The idea of using truncated potentials for the analysis of direct scattering phenomena was exploited earlier by Bellman

and Wing [38] and is discussed in Lamb [39]. This approach may also be regarded as an invariant imbedding method.

The differential method presented above for the reconstruction of the potentials $P(\cdot)$ and $Q(\cdot)$ seems to be related to the *trace method* of Deift and Trubowitz. Their method is based on the recursive computation of the Jost solution of the Schrodinger equation given by

$$\frac{d^2}{dx^2}f(x, \omega) + [\omega^2 - P(x)]f(x, \omega) = 0 \quad (4.20)$$

with boundary condition

$$\lim_{x \rightarrow \infty} f(x, \omega) \exp\{-j\omega x\} = 1 \quad (4.21)$$

Then, by substituting the trace formula

$$P(x) = \frac{2}{\pi} \int_{-\infty}^{\infty} j\omega \hat{R}(\omega) f^2(x, \omega) d\omega \quad (4.22)$$

into (4.20), $f(x, \omega)$ and $P(x)$ can be computed recursively for decreasing values of x . The connection between the approach of Deift and Trubowitz, and the algorithm that we have discussed above is not yet completely understood.

5. Integral Equations Formulation

In Section 3 the Schur recursions were derived by only using causality and the differential description of the medium. However most classical inversion methods are formulated in terms of integral equations. The objective of this section is to derive a set of Marchenko integral equations for the two-component system (2.9) and to show that these equations can be solved efficiently by a set of differential equations similar in form to the Schur recursions.

5.1. Transmission and scattering descriptions of the medium

The system (2.9) describes the transmission of waves through an infinitesimal section of the medium. These infinitesimal layers may be aggregated over the interval $[0, x]$ and by using the linearity of the medium we find that the waves $W_R(x, t)$ and $W_L(x, t)$ at depth x are related to the waves at the right boundary by

$$\begin{bmatrix} W_R(x, t) \\ W_L(x, t) \end{bmatrix} = \begin{bmatrix} M_{11}(x, t) & M_{12}(x, t) \\ M_{21}(x, t) & M_{22}(x, t) \end{bmatrix} * \begin{bmatrix} W_R(0, t) \\ W_L(0, t) \end{bmatrix} \quad (5.1)$$

where $*$ denotes the convolution operator. The matrix

$$M(x, t) = \begin{bmatrix} M_{11}(x, t) & M_{12}(x, t) \\ M_{21}(x, t) & M_{22}(x, t) \end{bmatrix} \quad (5.2)$$

is the transition matrix of the medium over $[0, x]$ and it satisfies the differential equation

$$\frac{\partial}{\partial x} M(x, t) = \begin{bmatrix} -\frac{\partial}{\partial t} & -k(x) \\ -k(x) & \frac{\partial}{\partial t} \end{bmatrix} M(x, t) \quad (5.3)$$

with initial condition

$$M(0,t) = \begin{bmatrix} \delta(t) & 0 \\ 0 & \delta(t) \end{bmatrix} \quad (5.4)$$

The aggregated medium corresponding to $M(x,t)$ can be viewed as obtained by composing the infinitesimal layers that were peeled off from the medium by the Schur algorithm over the interval $[0,x]$. Let $\hat{M}(x,\omega)$ be the Fourier transform of $M(x,t)$. Then, the composition procedure for generating $\hat{M}(x,\omega)$ and the layer peeling method are compared in Fig. 4.

Instead of using the transmission description of the medium given by (5.1) we can use an equivalent scattering description which relates the outgoing waves to the incoming waves, as follows

$$\begin{bmatrix} W_R(x,t) \\ W_L(0,t) \end{bmatrix} = \begin{bmatrix} T_L(x,t) & R_R(x,t) \\ R_L(x,t) & T_R(x,t) \end{bmatrix} * \begin{bmatrix} W_R(0,t) \\ W_L(x,t) \end{bmatrix} \quad (5.5)$$

The Fourier transform $\hat{S}(x,\omega)$ of the matrix

$$S(x,t) = \begin{bmatrix} T_L(x,t) & R_R(x,t) \\ R_L(x,t) & T_R(x,t) \end{bmatrix} \quad (5.6)$$

is the *scattering matrix* associated to the medium over $[0,x]$ and it can be obtained from $\hat{M}(x,\omega)$ by the relation

$$\hat{S}(x,\omega) = [P_+ \hat{M}(x,\omega) + P_-][P_- \hat{M}(x,\omega) + P_+]^{-1} \quad (5.7)$$

The general rules of composition of scattering layers are described in Redheffer [35].

As a consequence of the delay structure and losslessness of the elementary (infinitesimal) scattering layers described in Fig. 1, the scattering matrix $S(x,t)$ is such that

$$R_R(x,t) = R_L(x,t) = 0 \quad \text{for } t < 0 \quad (5.8)$$

$$T_R(x,t) = T_L(x,t) = 0 \quad \text{for } t < x \quad (5.9)$$

and it is lossless, i.e.

$$\hat{S}^H(x, \omega) \hat{S}(x, \omega) = I \quad (5.10)$$

where the superscript H denotes Hermitian transpose. In the transmission representation domain the relations (5.8) and (5.9) imply that the entries of $M(x, \cdot)$ have all support over $[-x, x]$. Finally, by noting that the transmission medium is invariant when the right and left propagating waves are interchanged and time is reversed, we get the following useful identities

$$\begin{cases} M_{11}(x, t) = M_{22}(x, -t) \\ M_{21}(x, t) = M_{12}(x, -t) \end{cases} \quad (5.11)$$

5.2. The Marchenko integral equations

When the medium is probed from the left, a consequence of its delay structure is that

$$W_R(x, t) = W_L(x, t) = 0 \quad \text{for } t < x \quad (5.12)$$

By substituting (5.12) into (5.1) and recalling that $M(x, \cdot)$ has support on $[-x, x]$, we obtain the system of integral equations

$$\begin{cases} \int_{-x}^t W_R(0, t - \tau) M_{11}(x, \tau) d\tau + \int_{-x}^t W_L(0, t - \tau) M_{12}(x, \tau) d\tau = 0 \\ \int_{-x}^t W_R(0, t - \tau) M_{21}(x, \tau) d\tau + \int_{-x}^t W_L(0, t - \tau) M_{22}(x, \tau) d\tau = 0 \end{cases} \quad (5.13)$$

which relates the entries of $M(x, t)$ to the measured waves $W_R(0, t)$ and $W_L(0, t)$, i.e. the scattering data. From the differential equation (5.3)-(5.4) satisfied by $M(x, t)$, it can be shown that $M_{11}(x, t)$ and $M_{21}(x, t)$ can be expressed as

$$\begin{aligned} M_{11}(x, t) &= \delta(x-t) + m_{11}(x, t)[u(x-t) - u(x+t)] \\ M_{21}(x, t) &= m_{21}(x, t)[u(x-t) - u(x+t)] \end{aligned} \quad (5.14)$$

Then, by using (5.14) and the symmetry relations (5.11), we get the *Marchenko*

integral equations (for $-x \leq t \leq x$)

$$\begin{cases} \int_{-x}^t W_R(0, t-\tau) m_{11}(x, \tau) d\tau + \int_{-t}^x W_L(0, t+\tau) m_{21}(x, \tau) d\tau = 0 \\ W_L(0, t+x) + \int_{-t}^x W_L(0, t+\tau) m_{11}(x, \tau) d\tau + \int_{-x}^t W_R(0, t-\tau) m_{21}(x, \tau) d\tau = 0 \end{cases} \quad (5.15)$$

which need to be solved for the functions $m_{11}(x, \cdot)$ and $m_{21}(x, \cdot)$. To guarantee the existence of solutions to these equations, it is as usual assumed that the probing wave $W_R(0, t)$ contains a leading impulse, see e.g. (3.1). In this case the integral equations (5.15) take the form of a system of coupled Fredholm equations of the second kind

$$\begin{cases} m_{11}(x, t) + \int_{-x}^t w_R(0, t-\tau) m_{11}(x, \tau) d\tau + \int_{-t}^x w_L(0, t+\tau) m_{21}(x, \tau) d\tau = 0 \\ w_L(0, t+x) + m_{21}(x, t) + \int_{-t}^x w_L(0, t+\tau) m_{11}(x, \tau) d\tau + \int_{-x}^t w_R(0, t-\tau) m_{21}(x, \tau) d\tau = 0 \end{cases} \quad (5.16)$$

The solution of these equations can be used to reconstruct the medium since from (5.3) and exploiting the form (5.14) of $M_{11}(x, t)$ and $M_{21}(x, t)$ we find that

$$k(x) = -2m_{21}(x, x-) \quad (5.17)$$

and

$$k^2(x) = 2 \frac{d}{dx} m_{11}(x, x-) \quad (5.18)$$

The equations (5.16) can be solved directly by using a simple discretization scheme. If the interval $[-x, x]$ is divided into N equal subintervals, this scheme would require $O(N^3)$ operations in order to reconstruct the reflection coefficient function over $[0, x]$.

However the kernels $w_R(0, t+\tau)$ and $w_L(0, t-\tau)$ which appear in (5.16) have respectively a Toeplitz and Hankel structure which can be exploited to reduce

the number of computations. Thus, note that $m_{11}(x,t)$ and $m_{12}(x,t)$ satisfy the differential system

$$\frac{\partial}{\partial x} \begin{bmatrix} m_{11}(x,t) \\ m_{21}(x,t) \end{bmatrix} = \begin{bmatrix} -\frac{\partial}{\partial t} & -k(x) \\ -k(x) & \frac{\partial}{\partial t} \end{bmatrix} \begin{bmatrix} m_{11}(x,t) \\ m_{21}(x,t) \end{bmatrix} \quad (5.19)$$

for $-x \leq t \leq x$, with initial conditions

$$m_{11}(0,0) = m_{21}(0,0) = 0 \quad (5.20)$$

When propagating (5.19), it turns out that we need to supply the values of the kernel $m_{21}(x, \cdot)$ at $t=x-$ (providing $k(x)$) and also the value of $m_{11}(x, \cdot)$ at $t=-x$. By using (5.17) and (5.18), $k(x)$ can be expressed as

$$k(x) = m_{21}(x, x-) = -w_L(0, 2x) - \int_{-x}^x w_L(0, x+\tau) m_{11}(x, \tau) d\tau - \int_{-x}^x w_R(0, x-\tau) m_{21}(x, \tau) d\tau \quad (5.21)$$

Furthermore setting $t = -x$ in (5.16) we find that

$$m_{11}(x, -x) = 0 \quad (5.22)$$

The differential system (5.19), with the boundary conditions (5.21) and (5.22), can now be used to compute $m_{11}(x,t)$ and $m_{21}(x,t)$ recursively. The equations (5.19) have the same form as the Schur recursions that were derived in Section 3. However the Schur algorithm is formulated as an initial value problem whereas the recursions derived above constitute a boundary value problem. These recursions are similar to the *Krein-Levinson* equations for factoring the resolvent of a Toeplitz kernel [27],[28]. They require the same order of computations as the Schur recursions. The stability of numerical schemes for propagating these two types of algorithms is discussed in Gohberg and Koltracht [40].

The differential equations (5.19) could have been derived also by applying the *displacement operators*

$$\tau = \frac{\partial}{\partial x} + \frac{\partial}{\partial t} \quad \text{and} \quad \mathfrak{v} = \frac{\partial}{\partial x} - \frac{\partial}{\partial t} \quad (5.23)$$

to the integral equations (5.16), and by using the displacement property

$$\tau f(x-t) = 0 \quad \text{and} \quad \mathfrak{v} f(x+t) = 0 \quad (5.24)$$

of Toeplitz and Hankel kernels. These displacement properties have been exploited in [27],[28] and [40] to derive some fast algorithms for the computation of resolvents of Toeplitz and Hankel operators and to obtain triangular factorizations of these operators. Anderson and Kailath, [41], also pointed out that the resulting fast algorithms can be used to solve the integral equations of classical inverse scattering theory.

5.3. Relation to classical inverse scattering

The integral equations (5.16) are expressed in terms of the general scattering data $W_R(0,t) = \delta(t) + w_R(0,t)u(t)$ and $W_L(0,t) = w_L(0,t)u(t)$. In the literature, two choices for the probing waves have been made either directly or implicitly

$$(i) \quad w_R(0,t) = 0 \quad \text{and} \quad w_L(0,t) = R(t)u(t) \quad (5.25)$$

$$(ii) \quad w_R(0,t) = w_L(0,t) = h(t) \quad (5.26)$$

The second choice above arises naturally when the scattering medium is terminated at its left boundary with a perfect reflector. The Marchenko integral equations that we have obtained above are therefore slightly more general than those presented in the literature of two-component inverse scattering problems [17],[39]. Furthermore they can be used to obtain the classical integral equations that solve the inverse scattering problem for the one-dimensional Schrodinger equation. To do so, denote by

$$K(x,t) = m_{11}(x,t) + m_{21}(x,t) \quad (5.27)$$

Then, by adding the two integral equations (5.16), we obtain

$$w_L(0,t+x) + K(x,t) + \int_{-x}^x [w_R(t-\tau) + w_L(t-\tau)] K(x,\tau) d\tau = 0 \quad (5.28)$$

where the potential is given by

$$P(x) = 2 \frac{d}{dx} K(x,x-) \quad (5.29)$$

In the special case when the scattering data is given by (5.25), the above equations correspond to the "classical" Marchenko solution of the inverse scattering problem [9],[15],[33]. When (5.26) is given as scattering data, it can be shown from (5.28) that the symmetrized kernel

$$K_S(x,t) = \frac{1}{2} [K(x,t) + K(x,-t)] \quad (5.30)$$

satisfies the Gelfand-Levitan equation [10],

$$K_S(x,t) + \frac{1}{2} [h(x+t) + h(x-t)] + \int_0^x \frac{1}{2} [h(|t-\tau|) + h(|t+\tau|)] K_S(x,\tau) d\tau = 0 \quad 0 < t < x \quad (5.31)$$

and again

$$P(x) = 2 \frac{d}{dx} K(x,x+) \quad (5.32)$$

Note that the symmetric kernel $K_S(x,t)$ is half the sum of all the entries in the transmission matrix $M(x,t)$.

Finally, if we define

$$L(x,t) = m_{11}(x,t) + m_{12}(x,t) \quad (5.33)$$

and use the scattering data (5.26), replacing t by $-t$ in the second equation in (5.16) and adding it to the first equation, we find that

$$h(x-t) + L(x,t) + \int_{-x}^x h(|t-\tau|)L(x,\tau)d\tau = 0 \quad (5.34)$$

This result is known as the Krein integral equation [8],[9],[13], and we have immediately that $K_S(x,t) = L(x,t) + L(x,-t)$. By noting that $m_{11}(x,-x) = 0$ and that $2m_{12}(x,-x) = k(x)$ we find that

$$k(x) = -2L(x,-x) \quad (5.35)$$

so that the local reflection coefficient function, and therefore the potential, can be reconstructed by this method.

This development shows that all the known solutions of the inverse scattering problem based on integral equations can be related to the differential approach that we have described in the previous sections. The integral equations based method of Gopinath and Sondhi [5],[6] may be regarded as using a special approach to the solution of Krein's equation. This method is of importance since the local impedance is directly recovered and a discussion of it can be found in Bruckstein and Kailath [42].

6. Inverse Scattering for General Media

The differential inversion methods that we have obtained above were restricted to the case of lossless scattering media. It is however possible to extend them to more general media, where the wave propagation is described by the two-component system

$$\frac{\partial}{\partial x} \begin{bmatrix} W_R(x,t) \\ W_L(x,t) \end{bmatrix} = \begin{bmatrix} -\frac{\partial}{\partial t} + a(x) & \beta(x) \\ b(x) & \frac{\partial}{\partial t} + \alpha(x) \end{bmatrix} \begin{bmatrix} W_R(x,t) \\ W_L(x,t) \end{bmatrix} \quad (6.1)$$

Such systems appear for example in the study of lossy transmission lines and acoustic media [26],[43]. The local loss function for this system is given by

$$-\frac{d}{dx} \int_{-\infty}^{\infty} [|\hat{W}_R(x,\omega)|^2 - |\hat{W}_L(x,\omega)|^2] d\omega = \int_{-\infty}^{\infty} [W_R^*(x,\omega) \ W_L^*(x,\omega)] \begin{bmatrix} -2a(x) & b(x)-\beta(x) \\ b(x)-\beta(x) & 2\alpha(x) \end{bmatrix} \begin{bmatrix} W_R(x,\omega) \\ W_L(x,\omega) \end{bmatrix} d\omega \quad (6.2)$$

which shows that a necessary and sufficient condition for losslessness is that, for all x ,

$$\begin{cases} a(x) = \alpha(x) = 0 \\ b(x) = \beta(x) \end{cases} \quad (6.3)$$

This is the case that was considered in the previous sections. An infinitesimal layer of the scattering medium corresponding to (6.1) is depicted in Fig. 5.

Since the scattering medium is parametrized by four different functions $\{a(\cdot), b(\cdot), \alpha(\cdot), \beta(\cdot)\}$, in general it will not be possible to reconstruct all of them from the pair of waves $W_R(0,t)$ and $W_L(0,t)$. The reconstruction techniques that will be discussed in this section therefore assume either that the parameters

$a(x)$, $\alpha(x)$ and $\beta(x)$ can be expressed as some function of $b(x)$, or that we have more information than the medium impulse response at $x=0$.

6.1. Reconstruction for a medium parametrized by $b(x)$ only

When the medium is entirely parametrized in terms of $b(\cdot)$ - as was the case, for example, for lossless media - the layer peeling procedure of Section 3 can be extended easily [42]. To do so, note that when the medium is probed by a wave $W_R(0,t)$ with a leading impulse, the waves at some depth x are of the form

$$\begin{cases} W_R(x,t) = \gamma_R(x)\delta(t-x) + w_R(x,t)u(t-x) \\ W_L(x,t) = w_L(x,t)u(t-x) \end{cases} \quad (6.4)$$

with

$$\gamma_R(x) = \exp\left\{\int_0^x a(\xi)d\xi\right\} \quad (6.5)$$

In this case

$$b(x) = 2\gamma_R^{-1}(x)w_L(x,x+) \quad (6.6)$$

and, since $\gamma_R(x)$ can be obtained from the previously reconstructed layers, equation (6.6) may be used to compute $b(x)$ for the next infinitesimal layer, which in turn determines $a(x)$, $\alpha(x)$ and $\beta(x)$. This implies that (6.1) and (6.6) can recursively compute the waves that propagate inside the medium and simultaneously recover the medium parameters.

The requirement that the medium be parametrized by $b(\cdot)$ alone might seem rather strong, however in the literature one often encounters papers that, after stating the problem in its full generality, introduce an equivalent assumption. It is also interesting to note that, in case the parameters $a(x)$, $\alpha(x)$ and $\beta(x)$ depend on $b(x)$ in a nontrivial way, it is not clear how the integral equations based inversion approaches can be extended.

6.2. Inverse scattering for a nonsymmetric system

Another example for which differential reconstruction methods can be devised is when $a(x) = \alpha(x) = 0$ in (6.1). In this case the resulting asymmetric two-component system is of the type considered by Zakharov and Shabat (see. e.g [16],[17]). The system (6.1) can in fact always be reduced to this particular form by performing the substitution

$$\begin{aligned} W_R(x,t) &\leftarrow \gamma_R^{-1}(x) W_R(x,t) \\ W_L(x,t) &\leftarrow \gamma_L^{-1}(x) W_L(x,t) \end{aligned} \quad (6.7)$$

where $\gamma_R(x)$ is given by (6.5) and

$$\gamma_L(x) = \exp\left\{\int_0^x \alpha(\xi) d\xi\right\} \quad (6.8)$$

In terms of these "normalized" variables, (6.1) becomes

$$\frac{\partial}{\partial x} \begin{bmatrix} W_R(x,t) \\ W_L(x,t) \end{bmatrix} = \begin{bmatrix} -\frac{\partial}{\partial t} & \beta(x) \frac{\gamma_L(x)}{\gamma_R(x)} \\ b(x) \frac{\gamma_R(x)}{\gamma_L(x)} & \frac{\partial}{\partial t} \end{bmatrix} \begin{bmatrix} W_R(x,t) \\ W_L(x,t) \end{bmatrix} \quad (6.9)$$

which is now in the form of an asymmetric two-component system. Let us define

$$k(x) = -b(x) \frac{\gamma_R(x)}{\gamma_L(x)} \quad \text{and} \quad k^A(x) = -\beta(x) \frac{\gamma_L(x)}{\gamma_R(x)} \quad (6.10)$$

The generalized Schur procedure that we derive next reconstructs the two functions $k(\cdot)$ and $k^A(\cdot)$ which are two independent functions of the original parametrization. Thus, unless $a(x) = \alpha(x) = 0$ for all x , this method will provide only a partial reconstruction of the original medium. Our presentation follows that of Yagle and Levy [44].

In addition to the causal pair of waves $W_R(0,t)$ and $W_L(0,t)$ that was used earlier as scattering data, it will be assumed that we are also given a *noncausal* wave pair

$$\begin{cases} W_L^A(0,t) = \delta(t) + w_L^A(0,t)u(-t) \\ W_R^A(0,t) = w_R^A(0,t)u(-t) \end{cases} \quad (6.11)$$

These waves can be viewed as obtained by exchanging the role of $W_R(\cdot)$ and $W_L(\cdot)$ and by reversing time in a scattering experiment. The corresponding reflection coefficient function

$$\hat{R}^A(\omega) = \frac{\hat{W}_R^A(0,\omega)}{\hat{W}_L^A(0,\omega)} \quad (6.12)$$

is the (1,2) entry of $\hat{S}^{-1}(\omega)$, where

$$\hat{S}(\omega) = \begin{bmatrix} \hat{T}_R(\omega) & \hat{R}_L(\omega) \\ \hat{R}_R(\omega) & \hat{T}_L(\omega) \end{bmatrix} \quad (6.13)$$

is the scattering matrix associated with the medium over $[0, \infty)$. It can therefore be obtained by probing the medium from both ends and measuring all the entries of $\hat{S}(\omega)$. Thus, even though the knowledge of the noncausal waves $W_L^A(0,t)$ and $W_R^A(0,t)$ is nonphysical, it can be assumed that $\hat{R}^A(\omega)$ or its anticausal inverse Fourier transform $R^A(t)$ is obtainable. For the case of a lossless medium, since $\hat{S}(\omega)$ is unitary, we have

$$\hat{R}^A(\omega) = \hat{R}(-\omega) \quad \text{and} \quad R^A(t) = R(-t) \quad (6.14)$$

so that this additional information is redundant.

The layer-peeling method can now be used for the asymmetric two-component system by noting that, at point x , the anticausal waves $W_L^A(x,t)$ and $W_R^A(x,t)$ have the form

$$\begin{cases} W_L^A(x,t) = \delta(x+t) + w_L^A(x,t)u(-x-t) \\ W_R^A(x,t) = w_R^A(x,t)u(-x-t) \end{cases} \quad (6.15)$$

and that

$$k^A(x) = 2w_R(x, -(x+)) \quad (6.16)$$

Therefore, by using the system (6.9) with the relations (3.3) and (6.16) to propagate both the causal and anticausal pairs of waves $\{W_R(x,t), W_L(x,t)\}$ and $\{W_L^A(x,t), W_R^A(x,t)\}$ simultaneously, we can recover both $k(\cdot)$ and $k^A(\cdot)$ in a sequential way.

In the transform domain the Riccati equations satisfied by

$$\hat{R}(x, \omega) = \frac{W_L(x, \omega)}{W_R(x, \omega)} \quad \text{and} \quad \hat{R}^A(x, \omega) = \frac{W_R^A(x, \omega)}{W_L^A(x, \omega)} \quad (6.17)$$

are

$$\frac{d}{dt} \hat{R}(x, \omega) = 2j\omega \hat{R}(x, \omega) + k^A(x) \hat{R}(x, \omega)^2 - k(x) \quad (6.18)$$

$$\frac{d}{dt} \hat{R}^A(x, \omega) = -2j\omega \hat{R}^A(x, \omega) + k(x) \hat{R}^A(x, \omega)^2 - k^A(x) \quad (6.19)$$

These equations can be propagated recursively by using the relations

$$\begin{aligned} \lim_{\omega \rightarrow \infty} 2j\omega \hat{R}(x, \omega) &= k(x) \\ \lim_{\omega \rightarrow \infty} -2j\omega \hat{R}^A(x, \omega) &= k^A(x) \end{aligned} \quad (6.20)$$

which have the effect of coupling (6.18) and (6.19).

An integral equations based solution of the above problem can be found in Ablowitz and Segur [17].

7. Conclusions

In this paper we have obtained differential inversion methods for identifying various parametrizations of lossless and nonlossless scattering media. Crucial in all the developments was the assumption that the given scattering data is noise-free, therefore the methods presented are *exact inversion algorithms*. These methods were also related to the classical approaches of Marchenko, Gelfand-Levitan and Krein which are based on solutions of Fredholm integral equations.

Two types of differential methods were described. The layer-peeling method, or equivalently the Schur recursions, directly exploited the physical structure of the medium to compute the propagating waves and to simultaneously recover its parameters. The corresponding algorithm was therefore formulated as an initial value problem. A second set of differential equations, the Krein-Levinson recursions, were also derived by exploiting the structure of the Marchenko integral equations. These differential equations have the same dynamics as the Schur recursions, however they require certain boundary values that have to be successively computed by invoking integral equations. The algorithms obtained via both approaches are both computationally efficient and numerically stable [40].

The results described in this paper could be extended in several ways. One of these would be their use for the propagation of solutions of certain nonlinear differential equations by the inverse scattering transform [16],[36]. Also, our analysis has been restricted to physical processes described by second-order differential equations. It would be interesting to generalize the differential approaches discussed in this paper to the study of inverse problems for more complex physical structures, described for example by general Hamiltonian systems.

References

- [1] J. A. WARE AND K. AKI, *Continuous and Discrete Inverse Scattering Problems in a Stratified Elastic Medium I: Plane Waves at Normal Incidence*, J. Acoust. Soc. of America, vol 45/4, pp. 911-921, 1969.
- [2] J. F. CLAERBOUT, *Fundamentals of Geophysical Data Processing*, McGraw-Hill, New York, 1976.
- [3] J. G. BERRYMAN AND R. R. GREENE, *Discrete Inverse Methods for Elastic Waves in Layered Media*, Geophysics, vol 45/2, pp. 213-233, 1980.
- [4] E. A. ROBINSON, *Spectral Approach to Geophysical Inversion by Lorentz, Fourier and Radon Transforms*, Proc. IEEE, vol 70/9, pp. 1039-1054, 1982.
- [5] B. GOPINATH AND M. M. SONDHAI, *Inversion of the Telegraph Equation and the Synthesis of Nonuniform Lines*, Proc IEEE, vol 59/3, pp. 383-392, 1971.
- [6] B. GOPINATH AND M. M. SONDHAI, *Determination of the Shape of the Human Vocal Tract from Acoustical Measurements*, Bell Syst. Tech. Journal, vol 49, pp.1195-1214, 1970.
- [7] L. WOHLERS *Lumped and Distributed Passive Networks*, Academic Press, New York, 1969.
- [8] L. D. FADDEEV, *The Inverse Problem of Quantum Theory of Scattering*, J. Math. Phys., vol 4/1, pp. 72-104, 1963.
- [9] K. CHADAN AND P. C. SABATIER, *Inverse Problems in Quantum Scattering Theory*, Springer-Verlag, New York, 1977.
- [10] F. DYSON *Old and New Approaches to the Inverse Scattering Problem*, in "Studies in Mathematical Physics", Essays in Honor of V. Bargmann, pp. 151-167, Princeton Series in Physics, Princeton, New Jersey, 1976.

- [11] I. M. GELFAND AND B. M. LEVITAN, *On the Determination of a Differential Equation from its Spectral Function*, Amer. Math. Soc. Transl., series 2, vol 1, pp. 253-304, 1955.
- [12] Z. S. AGRANOVICH AND V. A. MARCHENKO, *The Inverse Problem of Scattering Theory*, Gordon and Breach, New York, 1963.
- [13] M. G. KREIN, *On a Method for the Effective Solution of the Inverse Boundary Value Problem*, Dokl. Acad. Nauk SSSR, vol 94, pp. 987-990, 1954.
- [14] I. KAY AND M. E. MOSES (book) *Inverse Scattering Papers: 1955-1963*, Math. Sci. Press, Brookline, Mass, 1982.
- [15] L. D. FADDEEV, *Properties of the S-Matrix of the One-Dimensional Schrödinger Equation*, Amer. Math. Soc. Transl., series 2, vol 65, pp 139-166, 1967.
- [16] V. E. ZAKHAROV AND P. B. SHABAT *Exact Theory of Two-Dimensional Self-Focusing and One-Dimensional Self-Modulation of Waves in Nonlinear Media*, Sov. Phys. JETS, vol 34, pp. 62-69, 1972.
- [17] M. J. ABLOWITZ AND H. SEGUR, *Solitons and the Inverse Scattering Transform*, SIAM, Philadelphia, 1981.
- [18] M. S. HOWARD, *Inverse Scattering for a Layered Acoustic Medium Using the First Order Equations of Motion*, Geophysics, vol 48/2, pp. 163-170, 1983.
- [19] P. DEIFT AND E. TRUBOWITZ, *Inverse Scattering on the Line*, Comm. Pure and Appl. Math., vol 32/2, pp. 121-251, 1979.
- [20] I. SCHUR, *Über Potenzreihen, die im Innern des Einheitskreises Beschränkt Sind*, J. für die Reine und Angewandte Mathematik, vol 147, pp. 205-232, 1917.
- [21] N. I. AKHIEZER, *The Classical Moment Problem*, Hafner Publishing Co, New York, 1965.

- [22] P. DEWILDE, A. C. VIEIRA AND T. KAILATH, *On a Generalized Szego-Levinson Realization Algorithm for Optimal Linear Predictors Based on a Network Synthesis Approach*, IEEE Trans Circuits and Systems, vol CAS-25/9, pp. 663-675, 1978.
- [23] P. DEWILDE, J. T. FOKKEMA AND I. WIDYA, *Inverse Scattering and Linear Prediction, the Time Continuous Case* in Stochastic Systems: Mathematics of Filtering and Identification Applications, D. Reidel Publ. Co., Dordrecht, Holland, 1981.
- [24] W. SYMES, *Stable Solution of the Inverse Reflection Problem for a Smoothly Stratified Medium*, SIAM J. Math. Anal. 12, pp. 421-453, 1981.
- [25] F. SANTOSA AND H. SCHWETLICK *The Inversion of Acoustical Impedance Profile by Methods of Characteristics*, Wave Motion, vol 4, pp. 99-110, 1982.
- [26] M. M. SONDHI AND J. R. RESNICK, *The Inverse Problem for the Vocal Tract: Numerical Methods, Acoustical Experiments and Speech Synthesis*, J. Acoust. Soc. of America, vol 73/3, pp. 985-1002, 1983.
- [27] T. KAILATH, L. LJUNG AND M. MORF, *Generalized Krein-Levinson Equations for Efficient Calculation of Fredholm Resolvents of Nondisplacement Kernels*, in "Topics in Functional Analysis", essays in honor of M. G. Krein, Advances in Mathematics Supplementary Studies, vol 3, pp. 169-184, Academic Press, New York, 1978.
- [28] T. KAILATH, B. C. LEVY, L. LJUNG AND M. MORF, *The Factorization and Representation of Operators in the Algebra Generated by Toeplitz Operators*, SIAM J. Appl. Math, vol 37/3, pp. 467-484, 1979.
- [29] H. DYM AND H. P. McKEAN, *Gaussian Processes, Function Theory and the Inverse Scattering Problem*, Academic Press, New York, 1976.

- [30] R. G. NEWTON, *Inversion of Reflection Data for Layered Media: A Review of Exact Methods*, Geophys. J. Royal Astr. Soc., vol 65/1, pp. 191-215, 1981.
- [31] J. D. MARKEL AND A. H. GRAY, *Linear Prediction of Speech*, Springer-Verlag, New York, 1978.
- [32] E. A. ROBINSON AND S. TREITEL, *Geophysical Signal Processing*, Prentice-Hall, New Jersey, 1980.
- [33] R. BURRIDGE, *The Gelfand-Levitan, the Marchenko and the Gopinath-Sondhi Integral Equations of Inverse Scattering Theory Regarded in the Context of Inverse Impulse Response Problems*, Wave Motion, vol 2, pp. 305-323, 1980.
- [34] K. P. BUBE AND R. BURRIDGE, *The One-Dimensional Inverse Problem of Reflection Seismology*, to appear, SIAM Review, 1983.
- [35] R. REDHEFFER, *On the Relation of Transmission-Line Theory to Scattering and Transfer*, J. Math. Phys., vol XLI, pp. 1-41, 1962.
- [36] B. GJEVICK, A. NILSEN AND J. HOJEN, *An Attempt at the Inversion of Reflection Data*, Geophys. Prosp., vol 24, pp. 492-505, 1976.
- [37] V. BELEVITCH, *Classical Network Theory*, Holden-Day, San Francisco, 1968.
- [38] R. BELLMAN AND G. M. WING, *An Introduction to Invariant Imbedding*, J. Wiley and Sons, New York, 1975.
- [39] G. L. LAMB Jr., *Elements of Soliton Theory*, J. Wiley and Sons, New York, 1980.
- [40] I. GOHBERG AND I. KOLTRACHT, *Numerical Solutions of Integral Equations, Fast Algorithms and the Krein-Sobolev Equation*, The Weizmann Institute of Science, preprint, 1983.
- [41] B. D. O. ANDERSON AND T. KAILATH, *Fast Algorithms for the Integral Equations of the Inverse Scattering Problem*, Int. Eqns. and Operator Thy., vol 1/1, pp. 132-136, 1978.

- [42] A. M. BRUCKSTEIN AND T. KAILATH *Spatio-Temporal Scattering and Inverse Problems*, ISL Report, Stanford, 1983.
- [43] M. JAULENT, *The Inverse Scattering Problem for LCRG Transmission Lines*, J. Math. Phys., vol 23/12, pp. 2286-2290, 1982.
- [44] A. YAGLE AND B. C. LEVY, *The Schur Algorithm and its Applications*, LIDS Report, M. I. T., 1983

FIGURE CAPTIONS

Fig. 1: Discretized wave scattering layer.

Fig. 2: Integration path for the propagation of the layer-peeling algorithm.

Fig. 3: Discretized medium associated with the impedance reconstruction procedure.

Fig. 4: Comparison of the layer-peeling and layer aggregation methods.

Fig. 5: Wave scattering picture for a general medium.

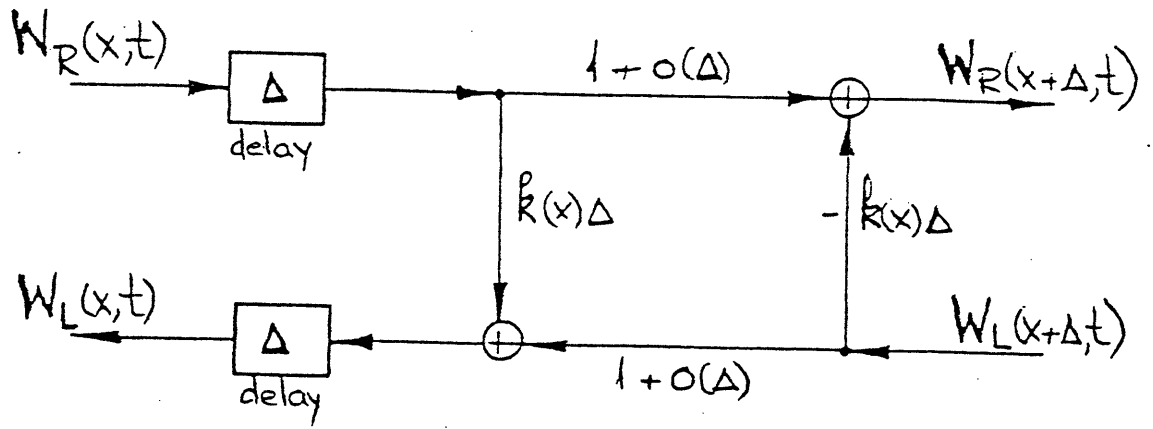

Fig 1.

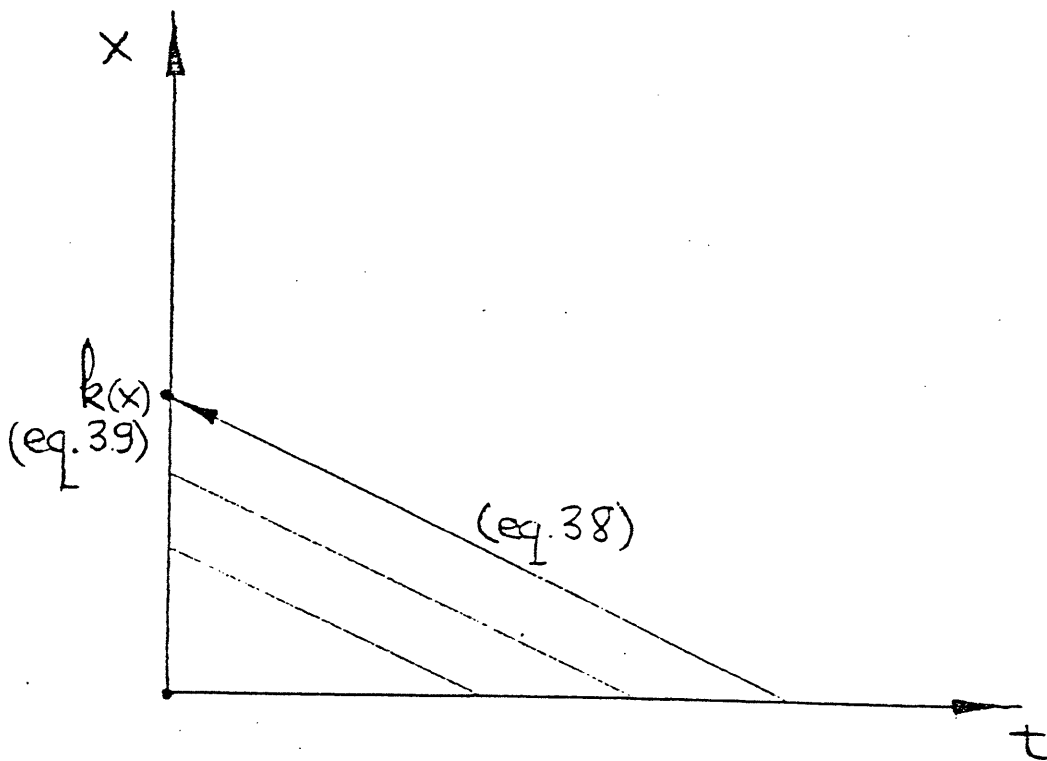

Fig 2.

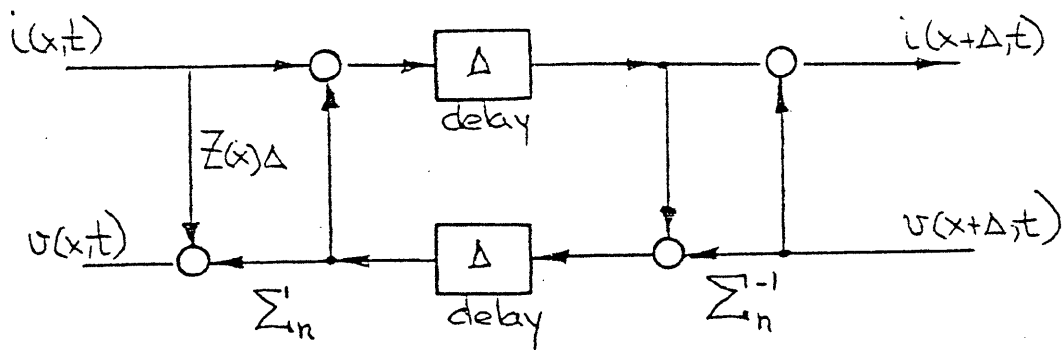

FIG 3.

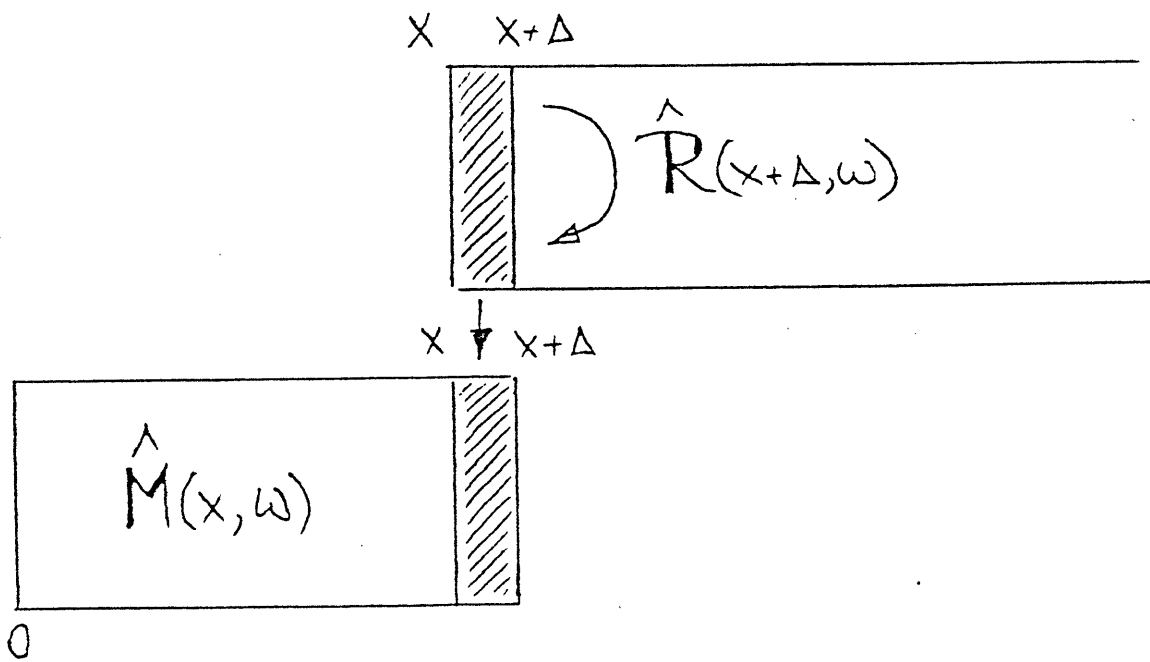

FIG 4.

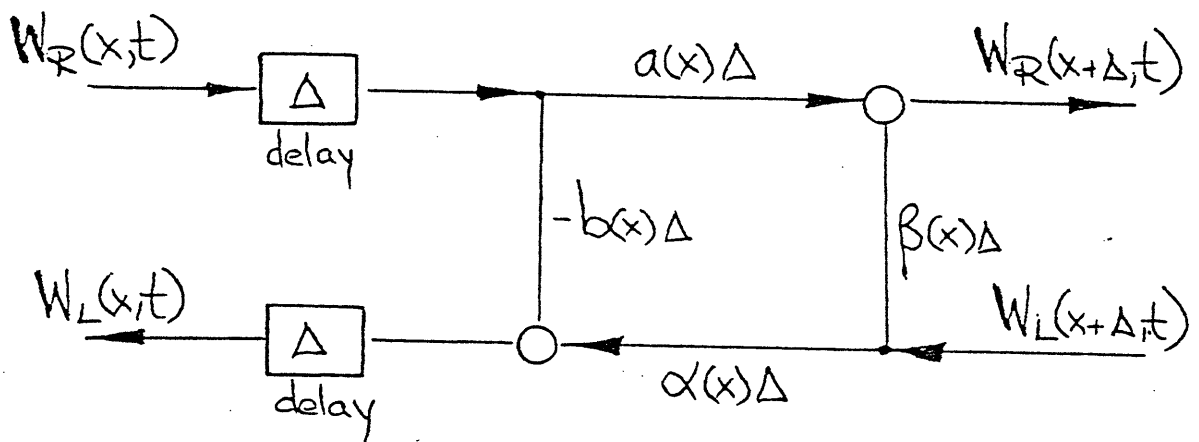

FIG 5.