

 Open access • Journal Article • DOI:10.1037/XGE0000774

Diffusion modeling and intelligence: Drift rates show both domain-general and domain-specific relations with intelligence. — Source link

Veronika Lerche, Mischa von Krause, Andreas Voss, Gidon T. Frischkorn ...+2 more authors

Institutions: Heidelberg University

Published on: 07 May 2020 - Journal of Experimental Psychology: General (American Psychological Association)

Topics: Information processing

Related papers:

- [A Theory of Memory Retrieval.](#)
- [Individual differences in components of reaction time distributions and their relations to working memory and intelligence](#)
- [Diffusion models in experimental psychology: A practical introduction.](#)
- [Neurocognitive Psychometrics of Intelligence: How Measurement Advancements Unveiled the Role of Mental Speed in Intelligence Differences:](#)
- [Individual Differences, Aging, and IQ in Two-Choice Tasks](#)

Share this paper:    

View more about this paper here: <https://typeset.io/papers/diffusion-modeling-and-intelligence-drift-rates-show-both-1a2z8fsm1a>



**University of
Zurich**^{UZH}

**Zurich Open Repository and
Archive**

University of Zurich
University Library
Strickhofstrasse 39
CH-8057 Zurich
www.zora.uzh.ch

Year: 2020

Diffusion modeling and intelligence: Drift rates show both domain-general and domain-specific relations with intelligence

Lerche, Veronika ; von Krause, Mischa ; Voss, Andreas ; Frischkorn, Gidon T ; Schubert, Anna-Lena ; Hagemann, Dirk

Abstract: Several previous studies reported relationships between speed of information processing as measured with the drift parameter of the diffusion model (Ratcliff, 1978) and general intelligence. Most of these studies utilized only few tasks and none of them used more complex tasks. In contrast, our study (N = 125) was based on a large battery of 18 different response time tasks that varied both in content (numeric, figural, and verbal) and complexity (fast tasks with mean RTs of ca. 600 ms vs. more complex tasks with mean RTs of ca. 3,000 ms). Structural equation models indicated a strong relationship between a domain-general drift factor and general intelligence. Beyond that, domain-specific speed of information processing factors were closely related to the respective domain scores of the intelligence test. Furthermore, speed of information processing in the more complex tasks explained additional variance in general intelligence. In addition to these theoretically relevant findings, our study also makes methodological contributions showing that there are meaningful interindividual differences in content specific drift rates and that not only fast tasks, but also more complex tasks can be modeled with the diffusion model.

DOI: <https://doi.org/10.1037/xge0000774>

Posted at the Zurich Open Repository and Archive, University of Zurich

ZORA URL: <https://doi.org/10.5167/uzh-197016>

Journal Article

Accepted Version

Originally published at:

Lerche, Veronika; von Krause, Mischa; Voss, Andreas; Frischkorn, Gidon T; Schubert, Anna-Lena; Hagemann, Dirk (2020). Diffusion modeling and intelligence: Drift rates show both domain-general and domain-specific relations with intelligence. *Journal of Experimental Psychology: General*, 149(12):2207-2249.

DOI: <https://doi.org/10.1037/xge0000774>

Diffusion Modeling and Intelligence:

Drift rates show both domain-general and domain-specific relations with intelligence

One of the processes that has often been discussed as basis of individual differences in intelligence is speed of information processing (Jensen, 2006). This notion is supported by consistent empirical results showing moderate relationships between general intelligence¹ and response times (RTs) from a broad range of cognitive tasks (Sheppard & Vernon, 2008). Regarding these relationships between intelligence and RTs, (at least) two important observations have been made in the last decades: (1) The relationship between RT and intelligence does not seem to be specific to content domains (verbal, figural, numeric; Levine, Preddy, & Thorndike, 1987; Neubauer & Bucik, 1996). (2) The slower responses within one task are more highly related to intelligence than the faster responses, resulting in the formulation of the *worst performance rule* (Larson & Alderton, 1990; for a review, see Coyle, 2003; for methodological considerations, see Frischkorn, Schubert, Neubauer, & Hagemann, 2016; for a meta-analysis, see Schubert, 2019). Thus, in brief, the relationship between intelligence and speed of information processing seems to depend on the speed of trials, but not or only to a small degree on the specific task content.

However, there are some methodological limitations of previous studies that examined the relationship between intelligence and speed of information processing. One of these limitations has been pointed out by Schmiedek, Oberauer, Wilhelm, Süß, and Wittmann (2007): Regarding the worst performance rule, they noted that previous studies employed different RT bands resulting in only restricted numbers of trials per band, thereby limiting the reliability of estimates. Instead of employing RT bands, Schmiedek et al. (2007) used a mathematical model that takes into account information about RT distributions, and thus has

¹ In this paper, we use the term *general intelligence* to denote a general factor that statistically emerges in intelligence tests (in the sense of sampling theories, e.g., Kovacs & Conway, 2016). Our use of the term general intelligence does not imply that we assume this factor to be a causal factor. In fact, our study does not have the aim of providing any inferences regarding the question of causality.

1 a considerably higher information usage—the diffusion model (Ratcliff, 1978; see Voss,
2 Nagler, & Lerche, 2013, for a review).

3 The diffusion model is a stochastic model that is applicable to binary response time
4 tasks and allows the separation of different, otherwise confounded, processes. One parameter
5 of this model—drift rate—is supposed to provide a pure measure of speed of information
6 processing, with other processes (such as speed of motoric response execution, or speed-
7 accuracy settings) “partialled out”. It is a known property of the diffusion model that changes
8 in drift rate have a larger influence on the tail than on the leading edge of RT distributions.
9 More specifically, Ratcliff and McKoon (2008) report that changes in the .9 quantile of RT
10 distributions are typically four times as large as changes in the .1 quantile. Changes in other
11 parameters of the diffusion model—which measure processes such as speed-accuracy settings
12 (threshold separation parameter) or the duration of encoding and motoric processes (non-
13 decision time parameter)—on the other hand, do not have this asymmetric influence on fast
14 vs. slow RTs. In line with this reasoning, Schmiedek et al. (2007) found the drift rate (but not
15 other diffusion model parameters) to be related to intelligence. In the following years, other
16 studies also supported the notion that intelligence as measured by classical intelligence tests
17 is associated with the drift rate (e.g., Ratcliff, Thapar, & McKoon, 2011; Schmiedek et al.,
18 2007; Schmitz & Wilhelm, 2016; Schubert, Hagemann, Voss, Schankin, & Bergmann, 2015).

19 In contrast to drift rate, mean RTs are influenced by a number of different processes
20 (e.g., how cautious individuals are and how fast they execute the motoric response). In fact,
21 for these other processes, for which the diffusion model provides distinct measures, no
22 consistent correlations with intelligence have been found. The only relationship that has been
23 reported several times is a small negative correlation of intelligence with non-decision time,
24 indicating that more intelligent people are faster in non-decisional processes, that is, in
25 encoding and/or motoric processes (McKoon & Ratcliff, 2012; Schubert et al., 2015; Schulz-

1 Zhecheva, Voelkle, Beauducel, Biscaldi, & Klein, 2016). In several other studies, however,
2 this relationship between intelligence and non-decision time has not been found (e.g.,
3 Schmiedek et al., 2007; Schmitz & Wilhelm, 2016). Critically, previous studies that
4 examined relationships between diffusion model parameters and intelligence are based on
5 only limited numbers of tasks and they used different estimation approaches, which might
6 account for inconsistencies in the findings.

7 To sum up, according to the literature distinct effects of speed of information
8 processing on RT distributions account for the worst performance rule. Furthermore, whereas
9 drift rate seems to be consistently related to intelligence, for the other diffusion model
10 parameters the current state of research is inconsistent. We will now come back to the
11 question of domain-specificity of mental speed. The diffusion model, which has proved
12 useful for the examination of the worst performance rule, might also help to gain further
13 insights into this finding.

14 Interestingly, previous studies did not find clear support for a three-factor structure
15 (numeric, figural, verbal) in RT tasks, suggesting that there are no substantial domain-
16 specific factors of speeds of information processing (Levine et al., 1987; Neubauer & Bucik,
17 1996). This observation is in contrast to findings from intelligence tests that assume a
18 hierarchical structure of intelligence with both a general factor and domain-specific factors
19 (e.g., verbal, numeric, figural; Jäger, Süß, & Beauducel, 1997). However, it might be difficult
20 to draw definite conclusions from the mental speed studies by Levine et al. (1987) and
21 Neubauer and Bucik (1996) as they did not explicitly disentangle processing speed from
22 other processes. The mental speed measures used in these studies might, thus, have been
23 distorted and may therefore have been no valid indicators of actual speed of information
24 processing. Notably, the studies did find a tendency for domain-specific correlations (i.e.,
25 higher correlations between intelligence and mental speed in the respective domains)

1 although their data did not contain compelling evidence for a hierarchical factor structure of
2 mental speed. Moreover, effects were not consistent and very small. Thus, we hypothesize
3 that the measures of processing speed used might not have been pure enough to find clear
4 support for domain-specificity. Using drift rate as a purer measure of cognitive speed
5 provides a more powerful and fairer test for the question, whether cognitive speed has stable
6 domain-specific components. The diffusion model literature, though, so far only reports one
7 general drift rate factor, and Schmiedek et al. (2007) see their results as suggesting that
8 “underlying mechanisms could be relatively task-independent” (p. 425). Notably, however,
9 previous diffusion model studies only used a very restricted number of tasks per domain.
10 Accordingly, the existing literature does not allow to draw clear inferences as to whether
11 there is only one common speed of information processing or whether there are domain-
12 specific speeds. It is further unclear whether domain-specific processing speeds (if they exist)
13 are related to the respective intelligence test scores or just to general intelligence.

14 To sum up, we see two important research gaps that have not been addressed by
15 previous studies analyzing the association of cognitive speed and intelligence with the
16 diffusion model framework. These gaps originate from restrictions in the number and breadth
17 of the employed tasks. First, whereas previous studies found clear evidence for an association
18 of drift rate and general intelligence, results regarding the other diffusion model parameters
19 are less clear-cut. Second, previous diffusion model studies did not vary task content
20 systematically, so it remains an open question whether there are also domain-specific factors
21 of cognitive speed, and whether such domain-specific speeds are related to the respective
22 intelligence test scores.

23 Another perspective on the research aims listed above relates to the diffusion model as
24 a diagnostic tool: Whereas, in the past, the diffusion model was mainly employed for the
25 analysis of differences between groups or conditions, in recent years it has been proposed to

1 use this methodology also for the analysis of *interindividual differences* in cognitive
2 processes (e.g., Frischkorn & Schubert, 2018; Ratcliff & Childers, 2015; White, Curl, &
3 Sloane, 2016). Our study allows for an examination of whether there are in fact meaningful
4 content-domain specific interindividual differences in the processing of information.

5 One further important goal of the present study is the comparison of easy (perceptual)
6 tasks vs. complex tasks (requiring more complex mental operations). In the past, it was often
7 recommended to apply the diffusion model only to tasks with mean trial RTs of up to 1.5
8 seconds (e.g., Ratcliff & Frank, 2012; Ratcliff & McKoon, 2008; Ratcliff, Thapar, Gomez, &
9 McKoon, 2004). Following this rule of thumb, the previous studies that examined links
10 between intelligence and drift rate used easy tasks that required no complex mental
11 operations and thus allowed for very rapid responding. Interestingly, first studies indicate that
12 the diffusion model might also be applicable to more complex tasks, requiring several
13 seconds for response selection (Aschenbrenner, Balota, Gordon, Ratcliff, & Morris, 2016;
14 Lerche, Christmann, & Voss, 2018; Lerche & Voss, 2017a). These studies, however, only
15 examined single tasks (e.g., a complex figural task in the studies by Lerche & Voss, 2017a)
16 and did not compare easy with more complex tasks. In the present study, we use a large
17 number of both easy and more complex tasks and examine whether the goodness-of-fit of the
18 diffusion model differs between data from easy vs. complex tasks.

19 Furthermore, we test the criterion validity of drift rate in the more complex tasks,
20 analyzing whether drift rate is related to intelligence not only in the fast, but also in the more
21 complex tasks. In fact, for more complex conditions stronger associations of intelligence and
22 mental speed have been reported (Sheppard & Vernon, 2008; see also Coyle, 2017;
23 Marshalek, Lohman, & Snow, 1983). More precisely, the relationship between intelligence
24 and mental speed increases from very simple tasks (RTs of about 300 ms) to moderately
25 complex tasks (RTs around 500-900 ms), but decreases again if tasks get even more complex

1 (RTs of more than 1200 ms; Jensen, 2005; see also Lindley, Wilson, Smith, & Bathurst,
2 1995). Thus, there seems to be an inverted-U-shaped relationship between task complexity
3 and the correlation between intelligence and mental speed. In our study, we examine “easy”
4 tasks (around 600 ms; i.e., moderately complex tasks according to the definition by Jensen)
5 and “complex” tasks (around 3000 ms). Jensen states the hypothesis that one reason for the
6 decrease from moderately complex to complex tasks is that individual differences in
7 performance strategies play a more important role in complex tasks. Furthermore, Lindley et
8 al. (1995) point out that in their complex task participants had to repeatedly scan between
9 different task elements resulting in supplemental motor time so that RT became a less
10 accurate measure of processing speed. Notably, drift rate is a more specific measure of
11 processing speed with some strategies (different speed-accuracy settings) or the duration of
12 encoding processes partialled out. Jensen also mentions that complex tasks show more task-
13 specific factors that can weaken the correlation between RT and g . As we use a large number
14 of tasks, we can use a structural equation modeling (SEM) approach, which helps us to
15 control for task specificities. Thus, the use of diffusion modeling and SEM provides us with
16 more specific measures of mental speed and the relationship between mental speed and
17 intelligence. Accordingly, in our study we assume a substantial relationship between drift rate
18 and intelligence also for the more complex tasks.

19 In the following paragraphs, we first give a brief introduction to the diffusion model
20 (for more detailed information, see Ratcliff, Smith, Brown, & McKoon, 2016; Voss, Nagler,
21 et al., 2013; Wagenmakers, 2009). Next, we present a review of previous studies that
22 examined relationships between intelligence and diffusion model parameters. In the
23 subsequent section, we present theoretical underpinnings of the relationship between drift rate
24 and intelligence. After that, we examine the question of whether the diffusion model is also

1 applicable to more complex RT tasks. Finally, we present the method and results of our
2 study.

3 **Introduction to the Diffusion Model**

4 The diffusion model (Ratcliff, 1978) is a mathematical model that is applicable to
5 decision tasks with two response options. When a participant works on a trial of such a binary
6 task (e.g., color discrimination task, see Voss, Rothermund, & Voss, 2004) she is assumed to
7 accumulate information continuously until she reaches one of two thresholds (see Figure 1).
8 The two thresholds represent either the two response options (response coding) or the
9 response accuracy (accuracy coding; e.g., Figure 1). The distance between the thresholds, the
10 so-called threshold separation (a) reflects how much information needs to be accumulated to
11 reach a decision. If individuals are more cautious, they will accumulate more information
12 before they decide for one option. In this case, a larger threshold separation will cause longer
13 RTs and—at the same time—higher accuracy because the decision processes will terminate at
14 the wrong threshold more rarely.

15 Speed of information processing is denoted as drift (v) and is illustrated by the arrows
16 in Figure 1, with steeper arrows indicating faster accumulation of information. During
17 information sampling, Gaussian noise is added constantly to the drift, reflecting random
18 fluctuations in the decision process. Due to this noise, the accumulation process does not
19 terminate after the same time and not always at the same threshold, even if the available
20 information (i.e., the stimulus) is identical. The two panels of Figure 1 illustrate the influence
21 of differences in drift on the RT distributions. It can be seen that if the drift is higher (Panel
22 B) fewer errors are made resulting in a smaller distribution at the error threshold and a larger
23 distribution at the correct response threshold. In addition, RT distributions for lower drift
24 rates (Panel A) are more spread out than those for higher drift rates. Another diffusion model
25 parameter is non-decision time (t_0) which subsumes the duration of all non-decision

1 A study by Schubert, Frischkorn, Hagemann, and Voss (2016) corroborates this idea.
2 The authors conducted a test-retest study with a time interval of eight months. They then used
3 latent state-trait analyses to disentangle trait influences and situation influences. The most
4 important finding was that drift rates had the highest consistencies, indicating that they were
5 the most trait-like parameters. Accordingly, drift rate might be a good candidate for
6 associations with intelligence, which is characterized by high temporal stability and great
7 consistency (Danner, Hagemann, Schankin, Hager, & Funke, 2011).

8 In support of this hypothesis, in several studies relationships between general
9 intelligence and drift rate have been reported (McKoon & Ratcliff, 2012; Ratcliff, Thapar, &
10 McKoon, 2010; Ratcliff et al., 2011; Schmiedek et al., 2007; Schmitz & Wilhelm, 2016;
11 Schubert et al., 2015; Schulz-Zhecheva et al., 2016). These studies measured drift rates from
12 performance in different types of binary tasks. For example, Ratcliff et al. (2010) used a
13 numerosity discrimination task, a recognition memory task, and a lexical decision task.
14 Intelligence was assessed by means of the Vocabulary and Matrix Reasoning subtests of the
15 Wechsler Adult Intelligence Scale. The authors observed substantial correlations between IQ
16 (mean over the two scales) and drift rate as measured in the lexical decision ($r = .53$) and
17 recognition memory task ($r = .55$). The correlation was smaller for the numerosity task ($r =$
18 $.24$). As also alluded to by the authors this is not astonishing, as the subscales of the
19 intelligence test that were administered did not address the numeric domain, but the verbal
20 (vocabulary subtest) and figural domain (matrix reasoning subtest). Only small-to-moderate
21 values were observed for the correlation of intelligence with threshold separation and non-
22 decision time ($|r|_{\max} = .33$).

23 In a subsequent paper, Ratcliff et al. (2011) reported correlations between IQ and
24 diffusion model parameters from an item recognition memory task and an associative
25 recognition memory task. Again, there were substantial correlations between the IQ scales

1 and drift rate with $r = .36-.68$ for college age participants and $r = .47-.67$ for participants aged
2 60-74 years. For the oldest group (75-90 years old), correlations were smaller ($r = .18-.34$),
3 which was seen as partly attributable to floor effects and lower reliability of the vocabulary
4 subtest. For threshold separation and non-decision time, an inconsistent pattern of mostly
5 small correlations with IQ emerged across tasks and age groups. McKoon and Ratcliff
6 (2012), who assessed participants of the same three age groups with the same two subtests of
7 the Wechsler Intelligence Scale, also found IQ to be correlated with drift rates for associative
8 recognition (r s between .24 and .68) and item recognition (r s between .49 and .68). In
9 addition, non-decision times were negatively related to IQ, suggesting faster encoding and/or
10 response execution of more intelligent participants.

11 Schubert et al. (2015) report results from three elementary cognitive tasks (Hick task,
12 Sternberg memory scanning task, and Posner letter matching task). Intelligence was assessed
13 in this study with Raven's Advanced Progressive Matrices and with a shortened version of
14 the knowledge test of the German Intelligenz-Struktur-Test 2000-R. In line with the results of
15 the previously reported studies, the authors observed a correlation of $r = .50$ between the
16 component score of drift rates from the different tasks (extracted from principal component
17 analyses) and general intelligence. In addition, like in the study by McKoon and Ratcliff
18 (2012), a negative relationship between intelligence and non-decision time emerged ($r = -$
19 .42). Thus, the more intelligent individuals not only showed higher drift rates but also shorter
20 non-decision times.

21 Schmiedek et al. (2007) used a larger number of different tasks: two lexical tasks, two
22 numeric tasks, and four spatial tasks. For the assessment of intelligence, the authors
23 employed tasks of the Berlin Structure of Intelligence Test (BIS; Jäger et al., 1997). More
24 specifically, three numeric, figural, and verbal tasks from the reasoning and psychometric
25 speed operation scales were used. Based on structural equation modeling (SEM), the authors

1 found that the latent factor of psychometric speed correlated highest with latent drift rate
2 ($r = .59$), whereas the correlations were smaller for threshold separation ($r = -.42$) and non-
3 decision time ($r = -.04$). Similarly, for reasoning the highest correlation emerged for drift rate
4 ($r = .79$; threshold separation: $r = -.48$; non-decision time: $r = .25$).

5 Schmitz and Wilhelm (2016) also reported relationships of drift with intelligence.
6 Using two different cognitive tasks and also employing SEM to link the drift rates to a
7 measure of fluid intelligence (a figural sequence reasoning test from the BEFKI; Wilhelm,
8 Schroeders, & Schipolowski, 2014) they found correlations with drift of $r = .15$ (non-
9 significant) for visual search and of $r = .29$ for visual comparison. The authors did not report
10 any significant correlations between fluid intelligence and the other diffusion model
11 parameters.

12 Schulz-Zhecheva et al. (2016) tested a sample of participants aged 8 to 18 years with
13 Cattell's Culture Fair Intelligence Test (CFT 20-R; Cattell & Cattell, 1960; Weiss, 2006) of
14 fluid intelligence and measured diffusion model drift rates across four simple decision tasks.
15 The latter consisted of deciding whether a number was odd or even, whether a number was
16 smaller or larger than 50, whether an arrow pointed upward or downward and whether a line
17 was shown in the upper or lower half of the screen. Once more, drift rate was by far the
18 strongest correlate of fluid intelligence (gf ; $r = .41$; non-decision time: $r = -.20$; threshold
19 separation: $r = -.13$). The total gf factor variance explained by the diffusion model parameters
20 was 19%.

21 In sum, drift rate seems to have a trait-like characteristic, showing moderate
22 consistency across different tasks and temporal stability. Moreover, robust relationships
23 between drift rates and intelligence have been reported across different studies and
24 experimental tasks. In contrast, correlations of the other diffusion model parameters with
25 intelligence are smaller and the pattern is less consistent. Apart from the relationship with

1 drift rate, the finding that has been most often reported is a negative correlation between
2 intelligence and non-decision time. However, this relationship only showed up in some of the
3 studies.

4 From the previous diffusion model literature, no clear conclusions can be drawn
5 regarding the existence of domain-specific drift rates. Whereas the findings by Schmiedek et
6 al. (2007) speak in favor of task-independence of speed of information processing, other
7 studies lend first support to the hypothesis that speed of information processing might differ
8 between domains. For example, Ratcliff et al. (2010) who measured intelligence with a verbal
9 and a figural test found a smaller correlation of intelligence with drift in a numeric task than
10 in a verbal or a figural task. Furthermore, in the study by Schubert et al. (2016) drift rates
11 showed smaller consistencies than typically observed in intelligence tests, suggesting that
12 individual differences in drift rates also reflect task- and content-specific properties to a
13 substantial degree. Importantly, a study that combines domain-specific intelligence
14 assessment with a battery of various RT tasks that tackle these domains is still missing. It is
15 an open question whether a domain-specific structure of speed of information processing can
16 be found and if so, if such domain-specific drift rates correlate with the respective domain
17 scores of an established intelligence measure. To address these questions, in our study, we
18 put together a battery of 18 different binary RT tasks that address the three different domains
19 of intelligence.

20 **Relationship between Drift Rate and Intelligence: Theoretical Considerations**

21 As we described in the last section, empirical findings support the view that speed of
22 information processing as measured by the drift rate of the diffusion model is related to
23 intelligence. Next, we will outline why this relationship is theoretically plausible and why we
24 assume that in more complex tasks relationships between drift rate and intelligence might be
25 even stronger than in less complex tasks.

1 For illustration, let us consider the two mechanisms proposed by Salthouse (1996) to
2 describe the assumed effect of age-related slowing on cognition, the *limited time mechanism*
3 and the *simultaneity mechanism*. The *limited time mechanism* is supposed to be in effect
4 when the time for solving a problem is limited and only little time is available for the higher-
5 order integration of information, because earlier stages of information processing occupied
6 too much time. The *simultaneity mechanism* assumes that, over time, information becomes
7 less available in working memory. If older individuals need more time to process
8 information, a greater amount of information will then be lost or at least fragmented by the
9 time they start to integrate all processed information. Accordingly, we assume that
10 individuals who have a reduced speed of information processing (i.e., a smaller drift rate) will
11 suffer more from time constraints, as they have less time available for higher-order
12 processing. Furthermore, for these individuals (in contrast to individuals with higher drift
13 rates) more information will get lost during the accumulation process. The importance of
14 temporal aspects in information-processing has also been stressed, for example, by the Time-
15 Based Resource-Sharing (TBRS) model (Barrouillet, Bernardin, & Camos, 2004; Camos &
16 Barrouillet, 2014). The model supports the view of a time-related decay of memory traces
17 and regards the number of necessary memory retrievals and the time given to perform them
18 as important factors influencing performance. More complex tasks will often require more
19 memory retrievals than simple RT tasks (e.g., perceptual or recognition memory tasks), with
20 time pressure kept constant between task types. Accordingly, more complex RT tasks might
21 be more vulnerable to deficits in speed of accumulation of information. In other words, task-
22 related differences in working memory demands might underlie higher relationships between
23 more complex tasks and intelligence.

24 A similar idea is part of the *process overlap theory* (Conway & Kovacs, 2015; Kovacs
25 & Conway, 2016, see also Kan, van der Maas, & Kievit, 2016), a recently proposed

1 intelligence theory. According to this theory “executive/attentional processes” play an
2 important role, underlying—amongst other—both the worst performance rule and the finding
3 of higher relationships with intelligence for more complex tasks. Process overlap theory is
4 considered a modern version of Thomson’s sampling theory (Thomson, 1916). According to
5 Thomson (1916), each mental test addresses a number of what has later often been called
6 “bonds” (see Deary, Lawn, & Bartholomew, 2008, for a historical analysis). This account
7 explains correlations of performance across tasks by an overlap of required psychological
8 processes (in the intelligence literature also often referred to as *positive manifold*). Rather
9 than assuming a causal general factor of intelligence, process overlap theory regards the *g*
10 factor—that undoubtedly shows up in any factor analysis of cognitive ability test data—as an
11 “emergent property” (p. 162, Kovacs & Conway, 2016).

12 In contrast to Thomson’s theory, process overlap theory does not postulate an additive
13 overlap of processes but assumes a bottleneck in form of multiplicatively linked
14 “executive/attentional processes” (Kovacs & Conway, 2016; see Schubert & Rey-Mermet,
15 2019, for a critical discussion of the empirical testability of this hypothesis). Kovacs and
16 Conway (2016) state that “*g* loadings depend on the involvement of executive processes
17 seated primarily in the prefrontal cortex rather than on the number of processes measured” (p.
18 170) and define *complexity* as “the extent to which a test taps executive/attentional processes”
19 (p. 164). Accordingly, they suppose the relationship between more complex tasks and
20 intelligence is driven by the engagement of executive processes. Similarly, it is assumed that
21 the slower trials in a task are more highly related to intelligence because they are indicators of
22 failures in executive processes. We support this view of a common explanation of both these
23 empirical observations. More specifically, we assume that the drift rate of the diffusion model
24 might provide a methodological account for both observations. It has already been
25 demonstrated that the drift rate provides an explanation for the worst performance rule (e.g.,

1 Schmiedek et al., 2007). So far, however, no study has examined relationships between
2 intelligence and drift rate in more complex tasks. In our study, we examine complex tasks
3 with RTs of about 3000 ms, thus tasks for which according to Jensen (2005) relationships
4 between mental speed and intelligence should be small because of higher influences of
5 individual differences in strategies. As the diffusion model provides a more specific measure
6 of mental speed (e.g., partialling out speed-accuracy settings), we assume that also for more
7 complex tasks there should be a substantial relationship between mental speed (measured by
8 means of the drift rate) and intelligence. This relationship might even be larger than for less
9 complex tasks because of higher memory demands.

10 In short, we suppose that a higher speed of information processing helps to counteract
11 time-related decay of memory. This might be particularly relevant for tasks with higher
12 memory demands. In our study, we examine both fast tasks with little memory demands and
13 more complex tasks with higher memory demands. As we will outline in the next section, we
14 assume that the diffusion model is also applicable to such more complex tasks.

15 **Diffusion Modeling for Fast vs. More Complex Tasks**

16 In the past, the diffusion model has almost exclusively been applied to *fast* tasks. By
17 this term, we refer here to tasks with a mean trial duration of below 1.5 seconds. The claim
18 that the diffusion model is only applicable to such fast tasks has been repeatedly put forth
19 (e.g., Ratcliff & Frank, 2012; Ratcliff & McKoon, 2008; Ratcliff, Thapar, et al., 2004) and
20 has strongly influenced the choice of tasks for diffusion modeling for a long time. The
21 reasoning underlying this restriction is that tasks with longer RTs were seen as more likely to
22 violate basic assumptions of the diffusion model (such as the assumption that decisions are
23 based on a single processing stage and that parameters remain constant over time within one
24 trial). However, we question the idea that data from more complex tasks are more likely to
25 violate assumptions of the diffusion model.

1 Let us first consider response time tasks that fulfill the 1.5 second rule, that is, typical
2 RT tasks to which the diffusion model has been applied frequently, such as a color
3 discrimination task. In this task, participants have to decide whether, for example, the color
4 orange or blue prevails in a square filled with pixels of these two colors (e.g., Germar,
5 Schlemmer, Krug, Voss, & Mojzisch, 2014; Voss et al., 2004). Participants are assumed to
6 sample evidence from the perceptual dimension (here, color). In such perceptual tasks, it is
7 plausible that participants continuously sample information (i.e., perceptions of color), until
8 they are reasonable sure that one color prevails. However, the diffusion model has also often
9 been applied to tasks in which a continuous sampling of information is less plausible.
10 Imagine, for example, the lexical decision task (Ratcliff, Gomez, & McKoon, 2004). Here it
11 is unclear, whether—during decision making—information of “wordiness” of a stimulus is
12 accumulated with constant drift. Rather, different pre-lexical (e.g., bigram frequencies) and
13 post-lexical (e.g., similarity to existing words) processes could inform the decision with
14 different impact, thus resulting in separate decision stages with different drift rates.

15 Since there is no way to assess the assumptions of the diffusion model analytically,
16 the model has to be validated empirically, both regarding its general ability to fit empirical
17 data and regarding the external validity of all model parameters. Such validation studies are
18 essential for any cognitive model and any new type of task. One important tool in this regard
19 are so-called selective influence studies that demonstrate that specific experimental
20 manipulations with high face validity take impact on specific model parameters in a specific
21 way. Importantly, such selective influence studies have shown comparably good validity of
22 the diffusion model parameters for color discrimination (Voss et al., 2004) and recognition
23 memory (Arnold, Bröder, & Bayen, 2015). Accordingly, even in the recognition memory task
24 the model assumptions are apparently not seriously violated.

1 Imagine now a more complex task, for example, the complex figural task used in our
2 study (see Figure 2, for an example stimulus). In each trial of this task, participants see
3 several rectangles. Half of the rectangles are surrounded by a blue border and half of them by
4 a red border. Participants have to estimate the total area of the blue-bordered rectangles and
5 compare it to the total area of the red-bordered rectangles in order to assess which of these
6 summed areas is larger. In studies by Lerche and Voss (2017a), the variant of the complex
7 figural task employed led to mean RTs of about 7 seconds per trial. Answers of participants
8 to an open-framed question about their use of strategies revealed that a typical strategy is to
9 sequentially pick pairs of rectangles and compare the two rectangles within one pair to each
10 other (i.e., one red- and one blue-bordered rectangle). Apart from the high perceptual and
11 spatial affordances (e.g., considering color of borders, and both width and height of
12 rectangles at different positions on the screen), also memory processes are relevant.
13 Participants need to remember which of the rectangles they have already compared and how
14 large the differences were. Thus, this task can be partitioned into several sub-tasks. For
15 example, each pair of rectangles could be seen as one sub-task (with each of these sub-tasks
16 consisting of further sub-tasks). Each sub-task might be conceived of as having its own speed
17 of information processing. Following the concept of the law of large numbers, with an
18 increase in the number of sub-tasks, extreme values of drift rate in single sub-tasks might
19 become less influential, allowing for an even better measurement of overall mental speed.
20 Thus, we assume that the data of tasks such as the complex figural task can be modelled
21 adequately by a constant drift (i.e., on average, information accrues towards the correct
22 boundary) with Gaussian noise (reflecting non-systematic influences).

23 Importantly, in selective influence studies based on the complex figural task,
24 convergent and discriminant validity of the diffusion model parameters were comparable to
25 what has been observed in the validation studies based on faster tasks (Lerche & Voss,

1 2017a). Furthermore, in another study, data from a complex *verbal* task were entered into a
2 diffusion model analysis (Lerche et al., 2018). In this task, participants had to assess the
3 meaningfulness of sentences, which took 2.2 seconds on average. Results again demonstrated
4 an excellent fit of the diffusion model. Thus, these first empirical findings support our claim
5 that the diffusion model can also be applied to tasks with mean response times above 1.5
6 seconds. In the present study, we build upon these promising results and employ both fast and
7 more complex tasks. We compare the model fit between these two types of tasks and examine
8 the external validity (analyzing the relationship of drift rate with intelligence).

9 **The Present Study**

10 In the present study, an intelligence test battery and a battery of 18 binary RT tasks
11 were administered to a sample of 125 participants. The RT tasks included both simple and
12 complex tasks addressing three content domains (numeric, figural, and verbal). With our
13 study, we pursued three main objectives: First, we aimed to replicate findings from previous
14 studies showing that general intelligence correlates with drift rate measured across a variety
15 of different tasks. That is, we expected a substantial relationship between general intelligence
16 and the drift rates across tasks. Second, we wanted to examine whether there are domain-
17 specific aspects of cognitive speed as measured by drift rates and—if so—whether these are
18 related to the respective numeric, verbal, and figural aspects of intelligence, as measured by
19 an intelligence test. Third, we aimed at further investigating the applicability of the diffusion
20 model to more complex RT tasks, which require more time for response selection.
21 Specifically, we compare model fit from nine fast and nine more complex tasks. We also
22 examine how drift rates estimated from the more complex tasks specifically predict general
23 intelligence.

1 **Method**

2 *Participants*

3 We determined the required minimum sample size for structural equation analyses
4 with a power analysis following the procedure described by Kim (2005). According to this
5 procedure, the proposed minimum sample size for a test of close model fit according to the
6 Root Mean Squared Error of Approximation (RMSEA) is 113 ($df = 350$, $\alpha = .05$, $\beta = .05$). We
7 recruited 125 participants for the study to ensure adequate power.²

8 We used different recruitment methods. The largest part of participants was recruited
9 via a newspaper article. Others were hired via the participants' pool of the Psychological
10 Institute of Heidelberg University in Germany using the software hroot (Bock, Baetge, &
11 Nicklisch, 2014) or by means of fliers that were distributed at public places. We obtained
12 informed consent from all participants. Participants were remunerated with 35€ after data
13 collection was completed. In addition, all participants received feedback about their
14 performance. Participants were between 18 and 65 years old ($M = 36.0$, $SD = 14.3$). Sixty-
15 three percent were females. The percentage of students amounted to 50%.

16 *Design and Procedure*

17 The study consisted of three sessions. In the first session, participants had to work on
18 an intelligence test³. In the second and third session, all RT tasks were administered (with
19 nine of these tasks in each session). The order of tasks was identical for all participants and is
20 provided in Table 1. Tasks of the three different domains and fast and slow tasks were
21 presented alternatingly. After the third and the sixth task within each session, participants
22 took a break of three minutes.

23 Each of the 18 tasks started with four practice trials. In these trials, participants

² Following suggestions of our reviewers, we kept the structural equation models simpler than in our original analysis plan. Most importantly, for the intelligence data, we used scale means rather than the single task scores, leading to a lower number of dfs in our models.

³ $N = 11$ participants had already participated in a previous study in which the same intelligence test was administered. These participants, therefore, only took part in the two PC assessments and received 25€.

1 received feedback about the correctness of their response (green checkmark vs. red cross for
2 correct vs. erroneous responses, respectively; presentation duration: 1500 ms). After the
3 practice trials, 100 test trials (preceded by one warm-up trial) were administered. All tasks
4 had a binary response format, with both responses correct in half of the trials. Simulation
5 studies have shown that the diffusion model can provide reliable parameter estimates for
6 about 100 or even fewer trials (Lerche, Voss, & Nagler, 2017). The practice and warm-up
7 trials were discarded from subsequent analyses. The order of trials was determined randomly
8 and was held constant for all participants. In each trial, participants had to press one of two
9 keys (“A” or “L”). The key assignment was identical for all participants. Each trial started
10 with the presentation of a fixation cross for 500 ms. Subsequently, the target was shown and
11 remained on the screen until the participant responded. Participants were instructed always to
12 respond as fast and accurately as possible. The next trial started after an inter-trial-interval of
13 500 ms.

14 The fast tasks took between 528 and 810 ms on average per trial ($M = 655$ ms) and the
15 slow tasks took between 2469 and 4314 ms ($M = 3319$ ms). The mean duration of assessment
16 sessions was 71 minutes for session 2 and 69 minutes for session 3.

17 *Intelligence Assessment*

18 For the assessment of intelligence we used the Berlin Intelligence Structure Test (BIS;
19 Jäger et al., 1997) which relies on the bimodal Berlin intelligence structure model (Jäger,
20 1982). This model comprises operation-related and content-related components of general
21 intelligence. Of interest to our study were the content-related components (numeric, figural,
22 and verbal). The intelligence assessment was run in sessions of six participants at maximum
23 and took on average 50 minutes.

24 Whereas Schmiedek et al. (2007) selected only nine tasks that were all taken from the
25 reasoning and psychometric speed operations, we also used the memory tasks of the short

1 scale BIS (BIS; Jäger et al., 1997), which resulted in a total of 12 tasks originating from three
2 of the four operations tapped in the test (reasoning, psychometric speed, memory, and idea
3 fluency). We excluded the tasks on idea fluency because they are more related to creativity
4 than to the construct of intelligence (cf. Schmitz & Wilhelm, 2016). Consequently, verbal,
5 numeric, and figural domains were represented by four tasks each. To keep the structural
6 equation models as simple as possible, we used scale means as manifest variables for each of
7 the three content domains.

8 ***Response-time Tasks***

9 The study consisted of 3 (domain: numeric vs. verbal vs. figural) \times 2 (speed: fast vs.
10 slow) \times 3 (number of tasks) = 18 different RT tasks (Table 1). In the following, we briefly
11 describe the different tasks and materials.

12 *Numeric Tasks*

13 The *fast numeric tasks* were the number discrimination task, the odd-even task, and
14 the simple inequation task. In the *number discrimination task*, participants saw a number in
15 each trial and had to assess whether this number was smaller or larger than 500. The numbers
16 were randomly drawn from a uniform distribution ranging from 100 to 900 (excluding 500),
17 with the restriction that half of the numbers were larger than 500 and that the mean deviation
18 from 500 was identical for the numbers smaller and the numbers larger than 500. In the *odd-*
19 *even task*, participants had to assess whether a presented number was odd or even. The
20 numbers were randomly drawn from a uniform distribution ranging from 100 to 899 (i.e., a
21 vector including 400 odd and 400 even numbers). In the *simple inequation task*, participants
22 had to decide which of two numbers displayed left and right of the center of the screen was
23 larger. The two simultaneously presented numbers were randomly drawn from a uniform
24 distribution ranging from 1 to 20, with the restrictions that numbers were never identical and
25 that the difference between the numbers did not exceed 3.

1 The *slow numeric tasks* were the mean value computation task, the equation task and
2 the complex inequation task. In the *mean value computation task*, 16 numbers were presented
3 on the screen. Participants had to assess whether the mean of these numbers was smaller or
4 larger than 500. The mean of the 16 simultaneously presented numbers of each trial was
5 either 400 or 600, and the numbers were presented at random positions on the screen
6 (overlapping of numbers was prevented). In the *equation task*, in each trial an equation was
7 shown and participants had to assess whether the equation was correct or wrong. In half of
8 the trials, a multiplication or division had to be performed, respectively. The erroneous
9 equations were generated using several different principles. Specifically, for erroneous
10 equations either the tens digit or the ones digit of the solution were set to incorrect values
11 (e.g., $5 \cdot 7 = 25$ or $4 \cdot 12 = 40$, respectively), the operator was wrong (e.g., $11/3 = 33$), or
12 the order of numerator and denominator was reversed (e.g., $8/64 = 8$). In the *complex*
13 *inequation task*, participants had to decide which solution of two equations displayed on the
14 left and right side of the screen was larger. The equations were sums and differences of two
15 numbers (e.g., “9 – 6” vs. “19 – 17”). The two numbers were drawn randomly from a uniform
16 distribution between 1 and 20, and the solutions of the sums and differences were in that
17 range as well. The operations for the two equations were randomly determined and could be
18 the same or different for the two equations. Furthermore, the difference between the solutions
19 of the two equations was restricted to a maximum of 3.

20 *Verbal Tasks*

21 The *fast verbal tasks* were the word category task, the lexical decision task, and the
22 animacy task. In the *word category task*, in each trial a word was presented and participants
23 had to assess whether the word was an adjective or a noun. All words comprised of six letters
24 and had one or two syllables. The words had frequency classes of 12 or above (according to
25 the online dictionary project of the university of Leipzig, retrieved in May 2017, see

1 <http://wortschatz.uni-leipzig.de/de>), which indicates that the German word “der” (“the”) is
2 used at least 2^{12} times as often as the selected stimuli. The mean frequency class of adjectives
3 and nouns was identical ($M = 15$). Thus, all words had a low frequency in German language.
4 In the *lexical decision task*, letter combinations were presented and participants had to assess
5 whether or not these were German words. The stimuli were selected from a lexical decision
6 study by Lerche and Voss (2017b). The words were nouns consisting of one or two syllables
7 and four to six letters. The words had a frequency class of 14 or 15 (retrieved in November
8 2014). The non-words had been generated by replacement of vowels from valid word. Thus,
9 all non-words were pronounceable and had plausible bigram frequencies. In the *animacy task*,
10 nouns were presented and participants had to classify these as living vs. nonliving. The
11 “living” stimuli could refer to humans, animals or plants. Two of the authors and two further
12 independent raters classified the words unambiguously as living vs. nonliving. The words
13 consisted of one to three syllables, four to eight letters, and had frequency classes between 11
14 and 16 (retrieved in June 2017). The mean frequency class was identical for words classified
15 as living or nonliving ($M = 13$).

16 The *slow verbal tasks* were the grammar task, the statement task, and the semantic
17 category task. In the *grammar task*, participants read German sentences with grammatical
18 errors and had to indicate whether the error was located in the possessive pronoun or in the
19 noun. All sentences consisted of five words and had a very similar structure: They always
20 started with a personal pronoun and further contained a predicate and an object with a
21 possessive pronoun (e.g., “Er widerspricht seine Chef oft.” = “He often contradicts his boss.”;
22 the error in the German statement is in the possessive pronoun that should read “seinem”
23 instead of “seine”). In each trial, by changing one word—either the possessive pronoun or the
24 object—the sentence could be corrected. The errors were generated using the wrong case

1 (e.g., accusative instead of dative), the wrong gender, the wrong declension, or the wrong
2 number.

3 In the *statement task*, four to six words were presented at different positions of the
4 screen. The participants had to assess whether or not it was possible to create a true statement
5 using all of the presented words. The words were distributed randomly across the screen.
6 From each set of words one grammatically correct sentence could be composed. An example
7 for a true statement is “ein Lastwagen ist sehr schwer” (“A truck is very heavy”) and for a
8 wrong statement is “reiche Menschen haben kein Geld” (“Rich people have no money”).

9 In the *semantic category task*, five nouns were presented one above the other. There
10 was one superordinate category to which most of the words (that is, three or four words)
11 belonged. Either one or two words did not belong to this category. Participants had to
12 indicate whether one or two words did not belong to this superordinate category. The selected
13 words were members of the superordinate categories planets, seating furniture, fruit, tools,
14 baking ingredients, medical specialists, geometric figures, grain, craftsmen, or organs
15 reported by Scheithe and Bäuml (1995). Either three or four words belonged to the same
16 category and one or two belonged to another superordinate category. For example, in one trial
17 the words “Stuhl” (= chair), “Sonne” (= sun), “Sessel” (= armchair), “Sofa” (= sofa), and
18 “Bank” (= bench) were shown. Here, the correct response was 1 because all words except one
19 (“sun”) belong to the same superordinate category “seating furniture”. In another example,
20 “Weizen” (= wheat), “Mond” (= Moon), “Jupiter” (= Jupiter), “Merkur” (= Mercury), and
21 “Hirse” (= sorghum) were presented. In this case, the correct response was 2, because two
22 nouns (“wheat” and “sorghum”) do not belong to the dominant category (planets). There are
23 10 different possibilities for the positioning of two minority category members among the
24 five words and five possibilities for the positioning of one minority category member. Each
25 possible positioning was used equally often.

1 *Figural Tasks*

2 Example illustrations of the figural tasks are depicted in Figure 2. The *fast figural*
3 *tasks* were the dot-rectangle task, the simple area task, and the polygon task. In the *dot-*
4 *rectangle task*, a rectangle and a dot were shown. Participants had to indicate whether the dot
5 was located within or outside of the rectangle. The rectangles varied in size while the dot was
6 always of the same size. The form of the rectangle and the exact positioning of the dot were
7 determined randomly. In the *simple area task*, two rectangles were shown side by side.
8 Participants had to assess which of the two rectangles was larger. The edge lengths of the
9 rectangles were determined randomly, with the area of the smaller rectangle always
10 comprising 70% of the area of the larger rectangle. In the *polygon task*, polygons were shown
11 and participants had to indicate whether the stimulus was a triangle or a quadrangle. The
12 shapes of polygons were generated randomly.

13 The *slow figural tasks* were the maze task, the complex area task, and the pie task. In
14 the *maze task*, mazes were presented with a dot positioned inside the maze. Participants had
15 to assess whether or not it was possible to leave the labyrinth (starting from the position of
16 the dot). The mazes were drawn manually with a graphics program. In the *complex area task*
17 (cf. Lerche & Voss, 2017a), in each trial six rectangles were shown. Three of them had a red
18 border and three of them had a blue border. Participants had to compare the total area of all
19 red-bordered rectangles with the total area of all blue-bordered rectangles and decide which
20 area was larger. The larger area was always 1.3 times larger than the smaller area. The
21 rectangles were generated randomly based on some restrictions (most importantly, the largest
22 or smallest area was not indicative of the correct answer so that participants really had to
23 assess the total area, see Lerche & Voss, 2017a, for details). In the *pie task*, three pie slices
24 were shown in each trial. Participants had to judge whether the three slices—if put together—
25 add up to more or less than a full circle. Between trials, the slices summed up to either 95%

1 or 105%, and each slice comprised between 5% and 95% of a full circle each. The
2 combinations of slices were generated randomly with the restriction that from the summing
3 of only two slices it was not possible to derive a correct answer.

4 ***Data preparation***

5 For all RT tasks, we discarded all responses faster than 300 ms. Furthermore, for each
6 task, trials lying more than three interquartile ranges beneath the first or above the third
7 quartile of the intra-individual logarithmized RT distributions were excluded (see also Tukey,
8 1977). The percentage of excluded trials was on average 1.3% per task and participant.

9 One participant interrupted accidentally the experimental program at the beginning of
10 the penultimate task of the session, so that data from two tasks (mean value computation task
11 and dot-rectangle task) are missing for this participant. Furthermore, separately for the
12 different RT tasks, we removed the diffusion model parameter estimates of participants with
13 inadequate model fit (i.e., fit < 1% quantile of the simulated data, see below for details on the
14 assessment of model fit; this resulted in an exclusion of 0.93% of the diffusion model
15 parameter estimates). Next, we also excluded the diffusion model parameter estimates, mean
16 RT and accuracy for a specific person and task if the accuracy rate or mean RT for this
17 specific task and person exceeded the Tukey criterion (i.e., distance from first or third
18 quartile larger than three times the interquartile range; Tukey, 1977)⁴. Finally, based on the
19 estimated diffusion model parameters (v , a , t_0), accuracy rates, mean RTs and intelligence
20 scale scores, we computed the Mahalanobis distances to detect multivariate outliers. Two of
21 our participants exceeded the critical value of $\chi^2 = 140.89$ ($df = 93$, $p = .001$) and thus had to
22 be excluded.

⁴ To test the robustness of our main findings, in additional analyses we excluded univariate outliers in the diffusion model parameters (because we had obtained some extreme estimates, e.g., $t_0 \approx 0$, $a \approx 10$, $v > 10$). The pattern of results remained unchanged when we excluded these values.

1 *Parameter Estimation*

2 We estimated the diffusion model parameters using the maximum likelihood
3 optimization criterion implemented in *fast-dm-30* (Voss & Voss, 2007; Voss & Voss, 2008;
4 Voss, Voss, & Lerche, 2015). Parameters were estimated separately for each participant and
5 each task. Thresholds were associated with correct (upper threshold) and erroneous (lower
6 threshold) responses. Accordingly, the starting point was centered between thresholds ($z_r =$
7 0.5). In addition, we fixed the intertrial variabilities of drift rate and starting point to zero.
8 These two parameters cannot be estimated reliably from low trial numbers and the fixation of
9 these parameters can even improve the estimation of the other model parameters (Lerche &
10 Voss, 2016; see also van Ravenzwaaij, Donkin, & Vandekerckhove, 2016). In sum, for each
11 participant and each task we obtained estimates for threshold separation, drift rate, non-
12 decision time, and the intertrial variability of non-decision time.

13 In order to examine the robustness of our results, we also conducted three additional
14 types of parameter estimation. In the first, we associated the thresholds with the two response
15 categories of the respective task (instead of correct and erroneous responses) and freely
16 estimated the starting point. This way, we could check if accounting for a possible bias in
17 starting point alters our results. With this estimation approach, we obtained two different drift
18 rate estimates per task, one for each response category, and—after multiplying the drift rate
19 for the category associated with the lower threshold by -1—computed the mean of the two
20 drift rates as an overall estimate of drift per task. In our second additional estimation
21 procedure, we examined whether practice effects might influence our pattern of results.
22 Therefore, prior to parameter estimation, we excluded not only the four practice trials and the
23 warm-up trial of each task, but also the subsequent 20 trials. Finally, we combined the two
24 alternative estimation approaches obtaining parameter estimates with a freely estimated
25 starting point while also excluding the 20 additional practice trials.

1 Some of the tasks employed in our study were similar to tasks that have already been
2 used for diffusion model analyses: Specifically, lexical decision tasks (e.g., Dutilh,
3 Vandekerckhove, Tuerlinckx, & Wagenmakers, 2009; Wagenmakers, Ratcliff, Gomez, &
4 McKoon, 2008; Yap, Balota, Sibley, & Ratcliff, 2012), number discrimination (Ratcliff,
5 2014; Ratcliff, Thompson, & McKoon, 2015), odd-even tasks (Schmiedek et al., 2007;
6 Schmitz & Voss, 2012), animacy discrimination tasks (Aschenbrenner et al., 2016; Spaniol,
7 Madden, & Voss, 2006; Voss, Rothermund, Gast, & Wentura, 2013), and the complex area
8 task (Lerche & Voss, 2017a) have been analyzed with the diffusion model before. However,
9 most tasks, in particular the slow RT tasks (with the exception of the complex area task),
10 have not yet been examined by means of diffusion modeling. Thus, we were particularly
11 interested in whether the model can fit data from all tasks (and especially from the slow
12 tasks) reasonably well. Accordingly, we examined the model fit for all tasks (our procedure is
13 reported in the Results section).

14 ***Structural Equation Modeling***

15 Our structural equation modeling approach consisted of two main steps. First, we
16 established a measurement model for drift rates and a model of the intelligence test scales,
17 separately. Then, we combined these two models into one complete model. We used the *R*
18 package *lavaan* (Rosseel, 2012) for the structural equation analyses. To deal with missing
19 data we employed the full information maximum likelihood (FIML) estimator included in
20 *lavaan*, which utilizes all available information.

21 We standardized all observed variables before they were entered into the structural
22 equations to avoid estimation problems resulting from differing variances between the drift
23 rates and the intelligence scale scores. As we were not interested in absolute values, fixing all
24 means to zero is unproblematic. However, the analysis of correlations instead of covariances
25 can lead to biased standard errors and fit indices (Cudeck, 1989). We accounted for this by

1 fixing the model implied indicator variances to one, equal to the manifest indicator variances,
2 as proposed by Cudeck. For examination of model fit we used several fit indices: the χ^2
3 statistic, the Comparative Fit Index (CFI), the Root Mean Square Error of Approximation
4 (RMSEA), and the Tucker-Lewis Index (TLI). We used the cut-off criteria proposed by Hu
5 and Bentler (1999) for evaluation of fit. Please note that due to the use of the FIML estimator,
6 a mean structure was also estimated. We fixed all estimated indicator means to zero (as the
7 variables were standardized), a fact that informs the degrees of freedom for all reported
8 models.

9 We compared four different measurement models of drift rate. Because it was
10 essential to keep the models as parsimonious as possible, we assumed parallel measurement
11 of all factors by fixing all factor loadings to one and setting all residual variances of items
12 loading onto the same factor equal (see Lord & Novick, 1968, Equations 3.3.1a and 3.3.1b,
13 for the outline of a model of parallel measurement). The four models are shown in Figure 3.
14 The first model (Model 1) assumed a general (*g*) factor of drift rate. This equals the
15 assumption that the common variance in speed of information processing can be explained by
16 a single, general factor contributing to all tasks. Model 2 did not include a *g* factor, but three
17 uncorrelated domain factors. The idea behind this model is that there are different types of
18 speed of information processing for figural, verbal and numeric tasks, and that these are
19 unrelated to one another. In Model 3, we assumed a hierarchical structure of the factors: *g*
20 was modeled as a higher-order factor and the domain factors as lower part of the factor
21 hierarchy. The general factor is here interpreted as the common variance of the domain
22 factors, which—in contrast to Model 2—are thought to be correlated. Thus, Model 3 assumes
23 that speed of information processing has both a general component and domain-specific

1 components⁵. Finally, in Model 4, we fit an extended version of Model 3 adding a factor that
2 captures the specific variance of the slow tasks (M-1 approach; Eid, Lischetzke, Nussbeck, &
3 Trierweiler, 2003). Here, the idea is that speed of information processing in the slower, more
4 complex tasks shares specific common variance. This way, the interpretation of the g factor
5 changes: It now comprises the domain-general shared variance of speed of information
6 processing except for the variance solely shared by the slow tasks. As not all of the models
7 are nested, we compare model fit based on AIC and BIC values.

8 For the BIS intelligence scales, we used a hierarchical model of domains and a
9 superordinate g factor (Intelligence Model, see Figure 4). We employed scale means (instead
10 of single item values) as single indicators for each domain (figural, numerical, verbal) to keep
11 the model as simple as possible, fixing residual indicator (not: domain) variances to zero.⁶
12 Domain factor variances were set equal for the three domains. We also fixed the
13 unstandardized loadings of the indicators on g and on the domain factors to 1. While this
14 assumption of perfect measurement and parallel structure is certainly an oversimplification,
15 we made this decision because the BIS is an established instrument and the focus of this
16 study is less on the structure of intelligence, but on the structure of speed of information
17 processing and its relationship to intelligence. In the last step, we combined the best fitting
18 model of drift rates and the BIS model (Combined Drift-Intelligence Model).

19 Although the focus of this work is on drift rate, we also fit the same model structures
20 (Models 1 to 4, see Figure 3) to estimates of threshold separation (a), non-decision time (t_0)

⁵ In the literature on the structure of mental abilities, there is an ongoing debate on how hierarchical models compare to so-called bifactor models (see, e.g., Morgan, Hodge, Wells, & Watkins, 2015). The latter assume a structure of both uncorrelated domain factors and a g factor, also orthogonal to the other factors. Thus, bifactor models do not make the presumption that the common variance shared by all tasks is due to the variance shared between the domain factors. Empirically, bifactor models often tend to fit better, while at the same time being less understood from a substantive, theoretical perspective (Kan, van der Maas, & Levine, 2019). Bifactor models fit better because with all loadings estimated freely hierarchical models are more constrained: The hierarchical models assume that the proportions of indicator variance accounted for by the domain (residual) factors and the proportions accounted for by g are the same for all indicators within a domain (Gignac, 2016). In our modeling approach, we fixed all factor loadings to be equal within each factor, which leads to a case where hierarchical and bifactor models are mathematically equivalent, yielding identical fit indices and estimates of the corresponding variances. We decided to use a hierarchical model instead of a bifactor model because it can be interpreted more intuitively and because it is also the more common model of cognitive abilities found in the literature.

⁶ Fixing the indicator variances to zero and using the domain factors as de-facto residuals was necessary to estimate the covariances between the drift domain residuals and the respective intelligence test components.

1 and mean logarithmized response times of correct responses. If a measurement model with
2 acceptable fit emerged, we further tested the combined model (i.e., including the intelligence
3 model). In the tables and plots, models are labeled accordingly (e.g., Drift Model 1 or RT
4 Model 1). The data of our study is available on the Open Science Framework project page:
5 https://osf.io/xpbwe/?view_only=2dbdd4d3d0cf4a5aa7229c6410593c0f.

6 **Results**

7 Tables A1 to A6 in the Appendix report descriptive statistics of response times,
8 accuracy rates, drift rates, threshold separations, non-decision times, and intelligence scores.
9 Figures A1 (fast tasks) and A2 (slow tasks) in the Appendix show boxplots of the response
10 times for all 18 tasks.

11 *Fit of the diffusion model*

12 Our analyses of model fit comprise two different approaches: First, we examined the
13 fit values of the maximum likelihood optimization. For better interpretation of these values,
14 we conducted simulation studies based on the estimated parameters to infer a criterion for the
15 assessment of model fit (Voss, Nagler, et al., 2013). Second, we analyzed model fit by means
16 of graphical illustrations comparing observed and estimated descriptive statistics.

17 In the maximum likelihood approach, parameter estimation is based on the
18 maximization of the sum of logarithmized densities over all responses. Boxplots illustrating
19 log-likelihood values for all tasks are given in Figure B1 (fast tasks) and Figure B2 (slow
20 tasks) in the Appendix. Higher likelihood values indicate a better fit of data to the model. One
21 problem with the interpretation of the log-likelihood values is that they depend on the
22 parameter ranges of the specific task. For example, the RT distributions of slower tasks are
23 more spread so that the sum of logarithmized densities is smaller (for an example illustration,
24 see Fig. 4 in Lerche & Voss, 2017a). This makes it difficult to compare the performance of
25 tasks with different parameter ranges.

1 To account for this, we conducted simulation studies. More specifically, for each task,
2 we generated 1,000 random parameter sets from multivariate normal distributions, with
3 means, variances, and covariances based on the distribution of estimated parameters. Thus,
4 simulated parameter sets were similar to observed parameters. From each parameter set, we
5 simulated one random data set (using *construct-samples*, which is part of the program *fast-*
6 *dm*). Therefore, simulated data reflects the assumption that data is based on a diffusion
7 process. Next, we re-estimated parameters from simulated data using the same *fast-dm*
8 settings as for the analyses of observed data (i.e., same number of estimated and fixed
9 parameters, same optimization criterion). If the fit values for the real data are worse than
10 those of the simulated data, the observed data probably do not result from a diffusion process
11 only, and consequently, results from the diffusion model analyses might be invalid.
12 Importantly, the distributions of log-likelihood values did not differ systematically between
13 observed data and simulated data, suggesting an excellent model fit (see Figures B1 and B2).

14 We further defined a criterion to quantify the percentage of observed data sets with
15 poor fit. Specifically, we computed the 1% quantile of the distribution of fit values from
16 simulated data. Maximum likelihood values below this criterion are assumed to indicate poor
17 model fit. This criterion is depicted as horizontal line in each plot. In addition, the plots give
18 the percentage of data sets with fit values below this criterion. The percentages of suspicious
19 fits are very low (at maximum 3.2%) and they are equal for the slow and fast tasks ($M =$
20 1.1%). This suggests that the diffusion model fits equally well for the fast and slow RT tasks
21 of our study.

22 We also examined the model fit graphically, in terms of the precision of predictions
23 for accuracy rates and RT quartiles. Specifically, we constructed scatter plots for each type of
24 task (domain \times speed) that show the correspondence of different statistics (RT quartiles and
25 accuracy rates) of observed data (x-axis) with the respective values predicted from the

1 diffusion model results (y-axis; see Figures B3 and B4 in the Appendix for the fast and slow
2 tasks, respectively). In these figures, each point represents one participant in one task. The
3 figures illustrate that the diffusion model fit the data very well as for all tasks the points are
4 close to the diagonals (all correlations between the empiric and the respective estimated
5 quartiles were larger than .97). Interestingly, the model fits at least as well for slow as for fast
6 RT tasks. Thus, the graphical fit analyses are in accordance with the simulation-based
7 analyses of maximum likelihood values.

8 The simulation studies and graphical analyses of model fit for the three alternative
9 types of estimation (including estimates of starting point, excluding additional practice trials,
10 and doing both) yielded similar results. The according plots are in the supplementary online
11 material.

12 *Structural Equation Modeling*⁷

13 We started by fitting the measurement models described above (Models 1 to 4, see
14 Figure 3) to the drift rate estimates: Model 1, a g factor model; Model 2, a model of
15 uncorrelated domains; Model 3, a hierarchical model of domains and a g factor; and Model 4,
16 a model that further added a method factor for all slow decision tasks. Table 2 shows the fit
17 indices for all drift rate models. Figures C1 to C4 in the Appendix show the results for Drift
18 Models 1 to 4 and Tables C1 to C4 in the Appendix report the parameter estimates for each of
19 the four structural equation models, including the unstandardized solution, the corresponding
20 standard errors and *p* values, and completely standardized estimates.

21 Model 4, the model containing a hierarchical structure of three content domain
22 factors, a superordinate g factor, and a method factor for the slow tasks had the best fit in
23 terms of AIC and BIC values (see Table 2) and also regarding the measures of absolute
24 model fit ($\chi^2 [df= 184] = 254.40$, CFI = .88; TLI = 0.90; RMSEA = 0.06). Accordingly, we

⁷ All the structural equation modeling analyses can be examined and replicated by executing the R Markdown file that we provide on the OSF project page.

1 decided to retain this model. It should be noted that the estimated residual variance of the
2 figural drift factor did not differ significantly from zero und should therefore be interpreted
3 accordingly. We kept it in the model in order to a) refrain from post hoc model adjustments
4 and b) make possible replications easier to compare.

5 The Intelligence Model is illustrated in Figure C5 in the Appendix, Table 2 shows the
6 fit, and Table C5 in the Appendix the parameter estimates. As the fit was good ($\chi^2 [df = 8] =$
7 0.18, CFI = 1.00; TLI = 1.03; RMSEA = 0.00), we used this model for the combined
8 analyses.

9 Finally, we combined the best measurement model of drift rates (i.e., Model 4) and
10 the Intelligence Model into a Combined Drift-Intelligence Model. We allowed freely
11 estimated covariances between residual figural drift rate and residual figural BIS intelligence,
12 residual numeric drift rate and residual numeric BIS intelligence, residual verbal drift rate and
13 residual verbal BIS intelligence, and the superordinate g factor for drift rate and g BIS
14 intelligence.⁸ In addition, the covariance between the slow decision task factor and the g BIS
15 intelligence factor was freely estimated, reflecting our hypothesis that speed of information
16 processing in slow tasks might be especially closely related to general intelligence. Figure 5
17 shows the resulting model. Model fit was acceptable ($\chi^2 [df = 241] = 406.49$; CFI = .82; TLI
18 = 0.84; RMSEA = 0.07; see Table 2). Table 3 shows the parameter estimates. All latent
19 factors except the figural drift factor had variances significantly different from zero; the same
20 was true for the covariances between them. The relative parts of the variances of the manifest
21 indicators explained by the latent factors are reported in Table 4. Across all tasks, 20% of the
22 variance of drift rates could be attributed to the g Drift factor, while 3-16% were based on the

⁸ We also fitted a Combined Drift-Intelligence Model freely estimating the covariances between all domain residuals. Only the theoretically implied covariances (Figural Drift <-> Figural IQ, Numeric Drift <-> Numeric IQ, Verbal Drift <-> Verbal IQ) reached statistical significance, except for a negative correlation between verbal drift and figural intelligence ($r = -.34, p = .048$).

1 domain-specific factors. For the complex tasks, an additional 10% of the variance was
2 explained by the slow factor. Overall, the mean task specific and error variance was 63%.

3 The estimated correlation between figural intelligence and figural drift rate was .90.
4 However, this value should not be over-interpreted because of the very low residual variance
5 of figural drift rate, which did not differ significantly from zero. Numeric intelligence and
6 numeric drift rate correlated with .74. The correlation between verbal intelligence and verbal
7 drift rate was .50, while the correlation between domain general drift rate and general
8 intelligence as measured by the BIS was .45. Finally, the method factor for slow decision
9 tasks and the BIS *g* factor were also strongly correlated ($r = .68$). If the links of the *g* drift and
10 slow drift factors to *g* BIS intelligence were modeled as a regression, the R^2 value of *g* BIS
11 was .67. Thus, the domain general drift factor and the slow drift factor jointly explained two
12 thirds of the variance in general intelligence.

13 We conducted several robustness checks to ensure our main findings would hold.
14 First, we fit models with completely freely estimated factor loadings and residual indicator
15 variances for both the best measurement model (Drift Model 4, freely estimated, see Figure
16 C6 and Table C6 in the Appendix; see Table 2 for fit indices) and the Combined Drift-
17 Intelligence Model (freely estimated, see Figure C7 and Table C7 in the Appendix; see Table
18 2 for fit indices). In terms of AIC and BIC values, the constrained Drift Model 4 was
19 preferred to the freely estimated version. For the Combined Drift-Intelligence Model, AIC
20 was lower for the free model, but the constrained model had the lower BIC value (i.e., better
21 fit). Please note that the number of estimated parameters in the freely estimated models is
22 very large for our sample size and the results should thus be interpreted with caution. In
23 addition, estimation of the Combined Drift-Intelligence Model (freely estimated) yielded a

1 non-positive definite estimated covariance matrix.⁹ Still, while the estimated unstandardized
2 factor loadings in the freed models sometimes differed widely from unity and standard errors
3 were much higher than in the constrained model, leading to statistically insignificant
4 estimates, the main resulting covariances remained much the same. Namely, the estimated
5 correlations between the factors in the freely estimated Combined Drift-Intelligence Model
6 (compared to the constrained Combined Drift-Intelligence Model) were: .56 (.90) for the
7 figural, .90 (.74) for the numeric, and .52 (.50) for verbal drift residual factors and their
8 respective intelligence counter-parts. A correlation of .42 (.45) was now found for the relation
9 of *g* Drift and *g* BIS and a correlation of .74 (.68) for the association of the slow factor and *g*
10 BIS.

11 Further evidence for the robustness of our results was provided by additional analyses
12 based on different specifications of the diffusion models: Similar results emerged for the
13 structural equation models when drift was estimated using the alternative diffusion model
14 architectures that a) also estimated the starting point, b) excluded 20 additional practice trials,
15 or c) did both. Fit indices and parameter estimates for these models are given in the
16 supplementary online material.

17 Table 5 shows the fit values for the measurement models of threshold separation, non-
18 decision time, and mean logarithmized response times. Parameter estimates for all these
19 models can be found in the supplementary online material. Of all the measurement models,
20 only *t*₀ Models 1, 3, and 4 showed somewhat acceptable model fit (RMSEA < 0.08, CFI and
21 TLI at least > 0.82), with Model 4 showing the lowest values in AIC and BIC. Thus, for non-
22 decision time, a hierarchical model of domain factors, a superordinate *g* *t*₀ factor and a
23 method factor for slow tasks provided the best fit. However, the residual variances for the

⁹ This problem could be overcome by fixing the residual variance of the Figural Drift factor, that did not differ significantly from zero, to zero.

1 RT of 660 ms), and the other half being more complex, slower tasks (mean RT of 3320 ms).
2 Thereby, our study is the first diffusion model study on intelligence that includes not only fast
3 but also more complex RT tasks and uses a large number of tasks per content domain. This
4 allowed us to examine three main substantial questions: First, we tested whether we can
5 replicate the relationship between general intelligence and drift rate that has been found in
6 previous diffusion model studies (e.g., Ratcliff et al., 2011; Schmiedek et al., 2007; Schmitz
7 & Wilhelm, 2016; Schubert et al., 2015). Additionally, we also examined relationships of
8 intelligence with mean RT and other diffusion model parameters. Second, we analyzed
9 whether there are domain-specific aspects of speed of information processing and—if so—
10 whether these domain-specific drift rate factors are related to the respective domains of the
11 intelligence test BIS (Berlin Intelligence Structure Test; Jäger et al., 1997).

12 In addition to these substantial questions, our study also allows the examination of
13 two methodological issues. First, in the last years it has been proposed to use the diffusion
14 model not only for the analysis of differences between groups or conditions (the typical
15 application in most previous studies), but also for the examination of interindividual
16 differences (e.g., Frischkorn & Schubert, 2018; Ratcliff & Childers, 2015; White et al.,
17 2016). Our study is the first to allow a profound analysis of whether there are meaningful
18 interindividual differences in the content-domain specific aspects of drift rates. Second, in the
19 past, the diffusion model was typically only applied to fast RT tasks. Our study allows
20 inferences about whether the diffusion model fits slower, more complex RT tasks similarly
21 well as typical fast RT tasks. Furthermore, we could examine the external validity of drift rate
22 in more complex tasks, analyzing the relationship with intelligence.

23 **Summary of Results**

24 The presented structural equation analyses replicated findings of previous diffusion
25 model studies in that we found a strong relationship between a general drift rate factor and

1 general intelligence as measured by the BIS. As the general latent factor of drift rates in our
2 study captured the shared variance of 18 different tasks, this provides strong support for the
3 hypothesis that speed of information processing is closely linked to general intelligence.
4 Furthermore, for two out of three content domains (verbal and numeric), we found significant
5 domain-specific drift factors, indicating that there are domain-specific interindividual
6 differences in mental speed that can be assessed with a diffusion model analysis. Strikingly,
7 the three domain-specific latent factors accounted for roughly one third of the shared variance
8 between tasks. Moreover, the domain-specific drift factors were closely related to the
9 respective components of the standard intelligence test. Finally, fit of diffusion models was
10 equally good for fast and more complex RT tasks and speed of information processing in the
11 more complex tasks explained additional variance in general intelligence.

12 **Domain-specific speeds of information processing**

13 Our study is the first to reveal domain-specific drift factors, which we further found to
14 be related to the respective domain scores of the intelligence test. The variance proportions
15 explained by the domain-specific drift factors for numeric and verbal drift are substantial
16 (15% and 16%), challenging the view of only one general mental speed factor. Thereby, our
17 study helps to reconcile research on mental speed with the literature that is based on standard
18 intelligence testing. In the latter, a hierarchical structure with both a *g* factor and domain-
19 specific factors is a very common assumption. Previous mental speed studies might have
20 failed to reveal domain-specific factors due to measurement issues. Specifically, studies that
21 did not employ the diffusion model might have examined a measure of mental speed that is
22 confounded by other processes such as encoding speed, motoric speed, or speed-accuracy
23 settings. The diffusion model has the great advantage of providing a more process-pure
24 measure of mental speed. Furthermore, previous studies employing the diffusion model might

1 have failed to find domain-specific drift rates because the number of tasks that had been used
2 for each domain might have been too low.

3 **Diffusion modeling for slower, more complex RT tasks?**

4 In the past, it was assumed that the diffusion model is only applicable to fast RT tasks
5 with mean trial RTs below 1.5 seconds (e.g., Ratcliff, Thapar, et al., 2004). However, first
6 studies support the notion that the model might also be utilized for more complex tasks.
7 Lerche and Voss (2017a) conducted experimental validation studies (also often called
8 “selective influence studies”) based on a complex figural RT task, and Lerche et al. (2018)
9 examined model fit of a complex verbal task. The present study offers a unique possibility to
10 compare model fit between easy and more complex tasks, because participants completed
11 both nine complex tasks and nine fast tasks, which were—beside the differences in cognitive
12 demands—very similar. Thus, we could compare model fit (in statistical terms and
13 graphically) between fast and slow tasks and examine correlations with intelligence.
14 Interestingly, the fit of the diffusion model was as good for the more complex as for the
15 simpler tasks.

16 Furthermore, in our structural equation modeling analyses, a model that included an
17 additional “slow drift factor” (i.e., a factor on which the drift rates of all slow tasks loaded)
18 fitted data better than models without this factor. Furthermore, this slow drift factor was
19 closely linked to general intelligence ($r = .68$). The explained variance (R^2) for drift rates
20 from slow tasks was slightly higher than for drift from fast tasks, due to the latent slow factor
21 that explained 10% of their variance. Thus, drift rates in the more complex tasks are closely
22 related to intelligence, which provides evidence for a good criterion validity of drift rates in
23 this kind of tasks.

24 The complex tasks that we employed in our study apparently differed in their
25 demands in terms of, for example, memory (e.g., high demands in the “complex area task”)

1 or reasoning (e.g., high demands in the “word category task”). We did not manipulate or
2 measure the specific demands in our study. However, it is notable that the diffusion model fit
3 all of our complex tasks very well, thus, fit was independent of the specific task demands. In
4 line with this finding are other recent studies that successfully applied sequential sampling
5 models to tasks with high demands on memory or reasoning. One of them applied the
6 diffusion model to a difficult recognition memory task (Aschenbrenner et al., 2016) and
7 another one applied the linear ballistic accumulator model (Brown & Heathcote, 2008) to an
8 inductive reasoning task (Hawkins, Hayes, & Heit, 2016).

9 **Advantages of the diffusion model**

10 Notably, the slow drift factor and the general drift factor together accounted for an
11 impressive 67% of the variance of general intelligence assessed by the BIS. It is striking that
12 drift rate has such a close relation to intelligence in the present study. In our view, this strong
13 relation—and the advantage of drift rate over mean RT—can be explained by two advantages
14 of the diffusion model.

15 First, unlike mean RT, the drift provides a common metric that combines both RT and
16 accuracy (Spaniol et al., 2006). Thus, when effects of cognitive ability spread over response
17 latencies and accuracy (i.e., higher ability is negatively related to RT and positively related to
18 accuracy of a task), a common metric is required that captures both effects. This is of special
19 importance, when the main impact of cognitive ability is for one group of participants on
20 speed and for others on accuracy.

21 Second, the diffusion model makes it possible to disentangle different processes of
22 information processing. Most important, different—and conceptually independent—
23 parameters map speed of information processing, speed-accuracy settings, and non-decision
24 times. For example, participants might be faster or slower, because they are less or more
25 cautious (i.e., error avoiding), respectively. Participants might also differ in the time needed

1 for encoding or motoric responses (i.e., non-decision time parameter). For example, it has
2 been consistently found that older participants are more cautious (i.e., higher threshold
3 separations) and that they have higher non-decision times than younger participants (see
4 Theisen, Lerche, von Krause, & Voss, 2019, for a meta-analysis). This example shows that
5 the validity of pure RT as a measure for mental speed might be problematic (see Coyle, 2017,
6 for a similar argument). In diffusion modeling, the response style (threshold separation) and
7 non-decision time are removed analytically from the index for mental speed (drift).
8 Therefore, drift rate is a more process-pure measure of mental speed than is mean RT, and is
9 thus a better predictor for intelligence.

10 **Are relationships with intelligence specific for drift rate?**

11 Importantly, in our structural equation analyses drift rates showed a clear pattern of
12 correlations with intelligence, distinguishing between domain-general and domain-specific
13 aspects, whereas the structural equation models of mean RT did not have a satisfactory fit.
14 Similarly, previous studies that used chronometric tasks and varied the type of material
15 (numeric, verbal, figural) failed to find clear support for domain-specific factors (Levine et
16 al., 1987; Neubauer & Bucik, 1996). These studies examined behavioral variables which—as
17 outlined in more detail in the previous section—are confounded with other processes
18 involved in task execution such as speed-accuracy settings.

19 Apart from drift rate, for non-decision time, we also observed relationships with
20 intelligence (fitting the same models as for drift rate resulted in a worse, but still acceptable,
21 model fit). Higher scores in the intelligence test were associated with shorter non-decision
22 times. Also in some previous studies, negative relationships between non-decision time and
23 intelligence have been reported (McKoon & Ratcliff, 2012; Schubert et al., 2015; Schulz-
24 Zhecheva et al., 2016), whereas in other studies no such relationship was found (e.g.,
25 Schmiedek et al., 2007; Schmitz & Wilhelm, 2016). Our study—which is based on a large

1 number of RT tasks and might thus allow more solid inferences than previous studies—
2 supports the view that there is also a relationship between non-decision time and intelligence
3 (even though this relationship is smaller than for drift rate).

4 What does this relationship between intelligence and non-decision time indicate? It
5 suggests that “intelligence” as measured by classical paper-and-pencil based intelligence tests
6 is more than speed of information processing. In fact, as already mentioned previously, not
7 only mean RTs in response time tasks, but also performance in paper-and-pencil-based
8 intelligence tests like the BIS can be influenced by different processes. In intelligence tests, it
9 is difficult to distinguish between the different processes that are involved in task completion,
10 such as decision settings (i.e., whether individuals prefer speed or accuracy), motoric
11 elements (e.g., how fast individuals write down their answers), encoding processes, and speed
12 of information processing.¹⁰ Thus, we suppose that non-decision time is related to the BIS
13 because also the paper-and-pencil-based test measures to a certain extent non-decisional
14 components. The non-decision time parameter of the diffusion model includes time needed
15 for encoding and motoric processes. We hypothesize that the correlations with intelligence
16 are probably mainly based on encoding processes rather than on motoric processes. It seems
17 implausible that for motoric components a model with not only a general factor, but also
18 domain-specific factors and a complex task factor emerges. In line with this argument, when
19 the *Jensen box* is used—which allows a separation of the time needed for decision making
20 (termed RT) from the time needed for finger movement (movement time)—RTs clearly
21 increase with increasing task complexity, whereas movement times do not (Jensen, 1987;
22 2006; see also the Differential–Developmental Model by Coyle, 2017). It is, however, highly
23 plausible that encoding processes differ between domains. Furthermore, the complex task

¹⁰ One notable exception is the explanatory model for performance in the Raven matrices by Carpenter, Just, and Shell (1990), in which different processes (incremental encoding, rule induction, goal management) were identified that contributed to the solution of the matrices. However, its application remains limited and its focus on Raven matrices forbids the generalization to other types of intelligence tests.

1 factor could be attributed to the fact that the stimuli in the more complex tasks consisted of
2 more elements than the stimuli in the fast tasks (e.g., several numbers distributed over the
3 screen in the mean value computation task in contrast to a single number presented in the
4 center of the screen in the number discrimination task). Accordingly, more complex tasks
5 pose higher demands on encoding than easier tasks. Importantly, by means of diffusion
6 modeling, we get a purer measure of speed of information processing with the time needed
7 for encoding and motoric components partialled out.

8 **Limitations and directions for future research**

9 We want to make clear that we do not claim that mental speed is causally related to
10 intelligence. In fact, a recent study based on an experimental approach did not find support
11 for a causal link between mental speed (as measured by the drift rate of the diffusion model)
12 and intelligence (Schubert, Hagemann, Frischkorn, & Herpertz, 2018). Rather, the authors
13 suggest that structural properties of the brain may give rise to the association between mental
14 speed and intelligence. The aim of our project was not to make any inferences regarding the
15 question of causality.

16 Diffusion modeling allows for an examination of interesting research questions
17 surrounding the g factor and other intelligence-related phenomena. One of these questions,
18 which we addressed in our study, is the examination of whether there are domain-specific
19 mental speeds. However, there are certainly further interesting research questions that could
20 be examined by means of diffusion modeling in the future, for example the factor
21 differentiation finding (e.g., Detterman & Daniel, 1989), which is regarded as one main
22 feature of g (Kovacs & Conway, 2016).

23 Apart from the examination of further intelligence-related phenomena, it would also
24 be important to explore relationships between drift rate and external criteria (e.g., grades at
25 school/university, or job performance). Presently, we have no data on the predictive validity

1 of drift rates for success in life; however, we think that future studies investigating this issue
2 are important. Because our analyses revealed that in particular drift rate in more complex RT
3 tasks showed strong relationships with intelligence, future research might focus on these
4 more complex tasks.

5 In future studies, one might also examine whether the results that we observed in our
6 study are moderated by the number of trials used in the RT tasks. Several diffusion model
7 studies found that drift rate grows over time (Dutilh et al., 2009; Lerche & Voss, 2017b;
8 Petrov, Van Horn, & Ratcliff, 2011). Possibly, the 100 trials per task used in our study still
9 give room for learning effects and relationships with intelligence might be even stronger or
10 possibly smaller if higher trial numbers were employed, so that more trials could be discarded
11 as practice trials.¹¹ A higher trial number would also increase reliability of estimates for drift
12 (Lerche & Voss, 2017b; Lerche et al., 2017).

13 One aspect that is common to both the assessment of intelligence with the BIS and our
14 computerized RT tasks (both “fast” and “slow” tasks) is the focus on speed. Chuderski (2013)
15 showed that this focus on speed can have an important impact. He found that working
16 memory capacity and fluid intelligence are isomorphic constructs when both are measured
17 under time pressure. If, on the other hand, fluid intelligence is measured with no real time
18 pressure, the relationship with working memory capacity decreases. The findings from the
19 study by Chuderski (2013) suggest that relationships between drift rate in speeded RT tasks
20 and intelligence measured under unspeeded conditions will probably be lower than the
21 relationships we observed in our study which focused on speed. However, the difference in
22 relationships between drift rate and speeded vs. unspeeded intelligence tests would possibly
23 be smaller than the differences between working memory capacity and speeded vs.

¹¹ Notably, our additional analyses in which we estimated parameters after exclusion of a larger number of practice trials did not result in a different pattern of results.

1 unspeeded fluid intelligence as measured by Chuderski, because the isomorphic relation
2 between working memory and fluid intelligence both assessed under speeded conditions
3 might be partly attributable to non-decision time (e.g., speed of encoding). If the diffusion
4 model is used, such influences can be “partialled out” so that we expect more similar
5 relationships between speeded vs. unspeeded intelligence testing and our performance
6 measure (drift rate). It would be interesting to examine the size of the relationship between
7 drift rate and unspeeded vs. speeded intelligence testing in future research and compare it to
8 the effect sizes found by Chuderski.

9 One final aspect that we want to point out is that our findings do not lend support to
10 an application of the diffusion model to all kinds of more complex, slower RT task. In tasks
11 that require significantly more time than the approximately three seconds observed in our
12 study, it becomes more likely that central assumptions of the diffusion model are seriously
13 violated. In future studies it would be interesting to analyze tasks with substantially longer
14 RTs (e.g., a matrices task with a mean RT of more than a minute; Partchev & De Boeck,
15 2012). Probably more important than the mean RT of a task are characteristics of the specific
16 task. Even fast tasks can be poor candidates for diffusion modeling (e.g., because no
17 continuous information uptake takes place). At the same time, even highly complex tasks that
18 consist of many sub-tasks might be compatible with the diffusion model. In our study, the
19 diffusion model provided a good fit for all employed tasks, and the relationships with
20 intelligence speak in favor of the validity of the parameter drift rate. These tasks are
21 interesting candidates for future diffusion model studies. If, however, researchers are
22 interested in applying the diffusion model to any new tasks, these tasks (whether fast or slow)
23 need to be carefully tested in terms of model fit and—even better—additionally with
24 validation studies.

1 **Conclusions**

2 Prior research revealed relationships between general intelligence and the drift
3 parameter of the diffusion model. This pattern proved to be robust in our structural equation
4 modeling of a set of 18 binary RT tasks. Additionally, we expanded this research showing
5 that there are content-domain specific (verbal, numeric, figural) aspects of cognitive speed,
6 which are related to the respective components of a standard intelligence test. Moreover,
7 slower, more complex tasks also proved to be closely linked to intelligence. Finally, we
8 supply several more complex binary RT tasks that were fit well by the diffusion model and
9 could thus be employed in future research projects.

1 Table 1
 2 *Overview of the 3 (domain: numeric vs. verbal vs. figural) × 2 (speed: fast vs. slow) × 3*
 3 *(number of tasks) = 18 RT tasks*

	fast	Slow
numeric	<ul style="list-style-type: none"> – FN1: number discrimination task (2.2) number is greater vs. smaller than 500 – FN2: odd-even task (1.5) number is odd vs. even – FN3: simple inequation task (2.8) inequation is correct vs. wrong 	<ul style="list-style-type: none"> – SN1: mean value computation task (1.8) 16 numbers with mean greater vs. smaller than 500 – SN2: equation task (2.5) equation is correct vs. wrong – SN3: complex inequation task (1.2) equation on left or right side is larger
verbal	<ul style="list-style-type: none"> – FV1: word category task (2.6) word is adjective vs. noun – FV2: lexical decision task (1.1) letter combination is word vs. non-word – FV3: animacy task (1.7) noun is living vs. nonliving 	<ul style="list-style-type: none"> – SV1: grammar task (1.4) sentence with grammatical error in possessive pronoun vs. noun – SV2: statement task (2.3) statement is correct vs. wrong – SV3: semantic category task (2.9) several nouns with one vs. two nouns not belonging to the superordinate category
figural	<ul style="list-style-type: none"> – FF1: dot-rectangle task (1.9) dot within vs. outside of rectangle – FF2: simple area task (2.4) rectangles with larger area on the left vs. right side – FF3: polygon task (1.3) polygon is triangle vs. rectangle 	<ul style="list-style-type: none"> – SF1: maze task (2.1) maze solvable vs. insolvable – SF2: complex area task (1.6) six rectangles with larger total area of red vs. blue bordered rectangles – SF3: pie task (2.7) three pie slices making more vs. less of a total pie

4 *Note.* The first letter indicates the task complexity (F = fast, S = slow); the second letter denotes the domain (N = numeric, V
 5 = verbal, F = figural). The numbers in parentheses indicate the time point of assessment (session and number in sequence).

1 Table 2

2 *Fit indices of Drift Rate Models, Intelligence Model, and Combined Drift-Intelligence Model*

Model	AIC	BIC	χ^2	df	CFI	TLI	RMSEA
Drift Model 1	5,773.69	5,776.50	350.71	188	.73	0.78	0.08
Drift Model 2	5,795.32	5,803.75	368.34	186	.69	0.75	0.09
Drift Model 3	5,711.05	5,722.30	282.07	185	.84	0.86	0.07
Drift Model 4	5,685.38	5,699.44	254.40	184	.88	0.90	0.06
Drift Model 4, freely estimated	5,688.59	5,772.96	207.61	159	.92	0.92	0.05
Intelligence Model	945.39	948.21	0.18	8	1.00	1.03	0.00
Combined Drift-Intelligence Model	6,507.19	6,538.12	406.49	241	.82	0.84	0.07
Combined Drift-Intelligence Model, freely estimated	6,496.67	6,603.53	341.97	214	.86	0.86	0.07

3 *Note.* Model 1: *g* factor model; Model 2: model of uncorrelated domains; Model 3: hierarchical model of domains and a *g*
4 factor; Model 4: Model 3 with additional method factor for all slow decision tasks. AIC = Akaike's Information Criterion.
5 BIC = Bayesian Information Criterion. CFI = Comparative Fit Index. TLI = Tucker-Lewis Index. RMSEA = Root Mean
6 Squared Error Of Approximation. The best-fitting drift rate model among the four alternative models (Models 1 to 4) is
7 highlighted. In the freely estimated models, all loadings and residual variances were unconstrained.
8

1 Table 3
2 *Combined Drift-Intelligence Model*

Parameter	Estimate	SE	95% CI	<i>p</i>	Std. Est.
Loadings					
Fv on v (each figural task)	1	0			0.487
Nv on v (each numeric task)	1	0			0.603
Vv on v (each verbal task)	1	0			0.591
sv on v (each slow task)	1	0			0.322
gv on Fv	1	0			0.919
gv on Nv	1	0			0.742
gv on Vv	1	0			0.758
gIQ on F_Mean/on N_Mean/V_Mean	1	0			0.734
FIQ on F_Mean/NIQ on N_Mean/VIQ on V_Mean	1	0			0.679
Covariances					
gv with gIQ	0.148	0.035	[0.080; 0.216]	<.001	0.450
sv with gIQ	0.162	0.030	[0.102; 0.222]	<.001	0.684
Fv with FIQ	0.117	0.031	[0.057; 0.177]	<.001	0.899
Nv with NIQ	0.202	0.035	[0.134; 0.269]	<.001	0.736
Vv with VIQ	0.130	0.034	[0.063; 0.197]	<.001	0.497
Latent (Residual) Variances					
gv	0.200	0.025	[0.152; 0.248]	<.001	1
gIQ	0.539	0.039	[0.462; 0.617]	<.001	1
sv	0.104	0.023	[0.059; 0.149]	<.001	1
Fv	0.037	0.028	[-0.017; 0.091]	.182	0.156
Nv	0.163	0.032	[0.100; 0.227]	<.001	0.449
Vv	0.149	0.031	[0.089; 0.209]	<.001	0.426
FIQ/NIQ/VIQ	0.461	0.039	[0.383; 0.538]	<.001	0.461
Residual Indicator Variances					
v (each fast figural task)	0.763	0.033	[0.698; 0.827]	<.001	0.763
v (each fast numeric task)	0.637	0.031	[0.576; 0.697]	<.001	0.637
v (each fast verbal task)	0.651	0.032	[0.589; 0.713]	<.001	0.651
v (each slow figural task)	0.659	0.034	[0.593; 0.725]	<.001	0.659
v (each slow numeric task)	0.533	0.034	[0.467; 0.599]	<.001	0.533
v (each slow verbal task)	0.547	0.032	[0.486; 0.609]	<.001	0.547

3 *Note.* Missing *p* values indicate fixed parameters. The standardized solution is completely standardized.

4

1 Table 4

2 *Percentage of variance explained by latent variables in manifest indicators in Combined*3 *Drift-Intelligence Model*

Task type	g Factor	Slow factor	Domain Factor	Residual
Fast Figural	20.03		3.70	76.27
Slow Figural	20.03	10.37	3.70	65.90
Fast Numeric	20.03		16.30	63.67
Slow Numeric	20.03	10.37	16.30	53.29
Fast Verbal	20.03		14.85	65.12
Slow Verbal	20.03	10.37	14.85	54.75

4

1 Table 5
 2 *Fit indices of threshold separation (a), non-decision time (t₀) and RT models*

Model	AIC	BIC	χ^2	df	CFI	TLI	RMSEA
<i>a</i> Model 1	5,594.45	5,597.26	485.09	188	.67	0.73	0.11
<i>a</i> Model 2	5,813.55	5,821.99	700.20	186	.43	0.53	0.15
<i>a</i> Model 3	5,597.19	5,608.44	481.84	185	.67	0.73	0.11
<i>a</i> Model 4	5,502.78	5,516.84	385.42	184	.78	0.82	0.09
<i>t</i> ₀ Model 1	5,610.96	5,613.77	316.75	188	.82	0.86	0.07
<i>t</i> ₀ Model 2	5,791.36	5,799.80	493.15	186	.58	0.65	0.12
<i>t</i> ₀ Model 3	5,607.52	5,618.77	307.31	185	.83	0.86	0.07
<i>t</i> ₀ Model 4	5,587.65	5,601.71	285.44	184	.86	0.88	0.07
Combined <i>t</i> ₀ -Intelligence Model	6,457.09	6,488.03	390.73	241	.84	0.86	0.07
RT Model 1	4,924.20	4,927.01	796.82	188	.68	0.74	0.16
RT Model 2	5,105.80	5,114.23	974.41	186	.59	0.66	0.19
RT Model 3	4,834.62	4,845.87	701.24	185	.73	0.78	0.15
RT Model 4	4,802.50	4,816.56	667.12	184	.75	0.79	0.15

3 *Note.* Model 1: *g* factor model; Model 2: model of uncorrelated domains; Model 3: hierarchical model of domains and a *g*
 4 factor; Model 4: Model 3 with additional method factor for all slow decision tasks. AIC = Akaike's Information Criterion.
 5 BIC = Bayesian Information Criterion. CFI = Comparative Fit Index. TLI = Tucker-Lewis Index. RMSEA = Root Mean
 6 Squared Error Of Approximation. The best-fitting model among the four alternative models (Models 1 to 4) is always
 7 highlighted.
 8

1 Table 6
2 *Combined t_0 -Intelligence Model*

Parameter	Estimate	SE	95% CI	<i>p</i>	Std. Est.
Loadings					
F_{t_0} on t_0 (each figural task)	1	0			0.540
N_{t_0} on t_0 (each numeric task)	1	0			0.579
V_{t_0} on t_0 (each verbal task)	1	0			0.614
st_0 on t_0 (each slow task)	1	0			0.275
gt_0 on F_{t_0}	1	0			1.016
gt_0 on N_{t_0}	1	0			0.948
gt_0 on V_{t_0}	1	0			0.894
gIQ on F_Mean/N_Mean/V_Mean	1	0			0.731
VIQ on V_Mean/NIQ on N_Mean/VIQ on F_Mean	1	0			0.682
Covariances					
gt_0 with gIQ	-0.266	0.031	[-0.327; -0.206]	<.001	-0.663
st_0 with gIQ	-0.023	0.025	[-0.071; 0.026]	.358	-0.112
F_{t_0} with FIQ	-0.047	0.027	[-0.101; 0.007]	.086	-0.709
N_{t_0} with NIQ	-0.103	0.030	[-0.161; -0.045]	.001	-0.819
V_{t_0} with VIQ	-0.113	0.032	[-0.176; -0.051]	<.001	-0.604
Latent (Residual) Variances					
gt_0	0.301	0.021	[0.260; 0.343]	<.001	1
gIQ	0.535	0.041	[0.455; 0.615]	<.001	1
st_0	0.076	0.019	[0.039; 0.113]	<.001	1
F_{t_0}	-0.010	0.022	[-0.052; 0.033]	.657	-0.033
N_{t_0}	0.034	0.023	[-0.012; 0.080]	.146	0.101
V_{t_0}	0.076	0.026	[0.025; 0.127]	.003	0.201
FIQ/NIQ/VIQ	0.465	0.041	[0.385; 0.545]	<.001	1
Residual Indicator Variances					
t_0 (each fast figural task)	0.708	0.029	[0.651; 0.765]	<.001	0.708
t_0 (each fast numeric task)	0.665	0.029	[0.609; 0.721]	<.001	0.665
t_0 (each fast verbal task)	0.623	0.028	[0.567; 0.678]	<.001	0.623
t_0 (each slow figural task)	0.633	0.030	[0.574; 0.691]	<.001	0.633
t_0 (each slow numeric task)	0.589	0.030	[0.529; 0.649]	<.001	0.589
t_0 (each slow verbal task)	0.547	0.031	[0.486; 0.608]	<.001	0.547
F_Mean/N_Mean/V_Mean	0	0			

3 *Note.* Missing *p* values indicate fixed parameters. The standardized solution is completely standardized.

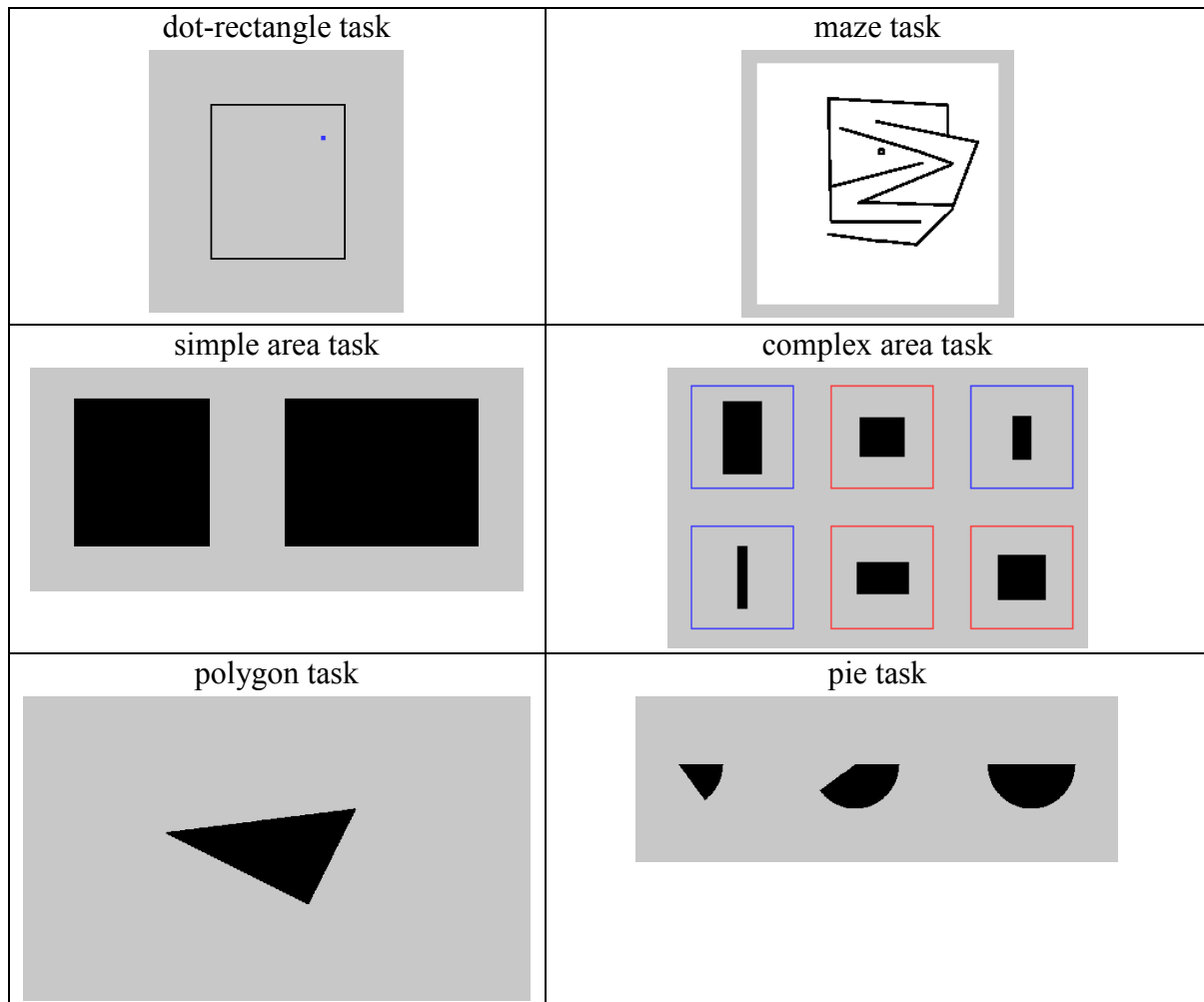

Figure 2. Example for stimuli from the fast figural tasks (left) and the slow figural tasks (right).

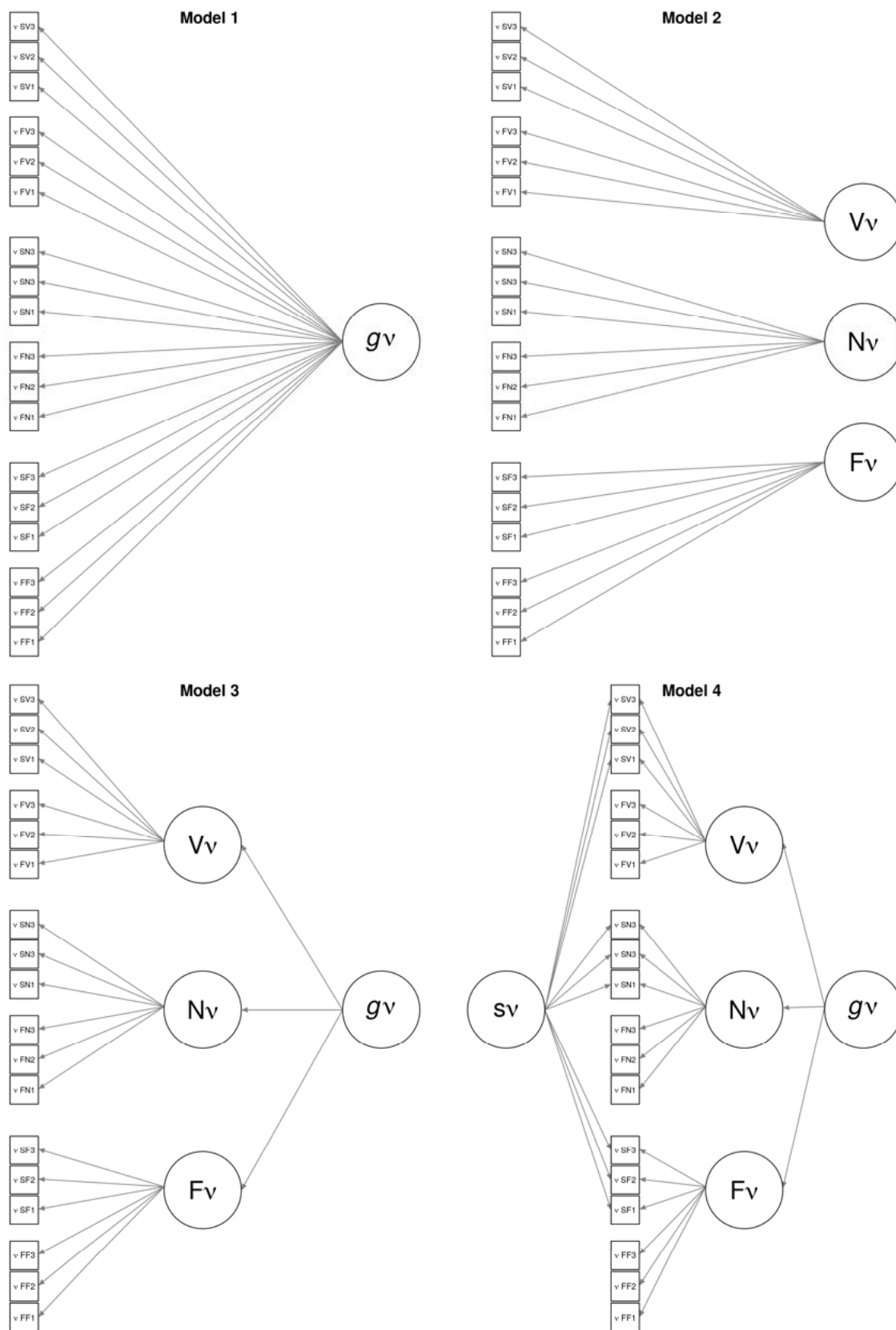

Figure 3. Drift Rate Models 1 to 4. The first letter of the task indices denotes the type of task (F = fast, S = slow); the second letter indicates the domain (N = numeric, V = verbal, F = figural). See Table 1 for a brief description of all tasks. g_v = general drift rate factor, V_v = verbal drift rate factor, N_v = numeric drift rate factor, F_v = figural drift rate factor, sv = method factor for drift rate in slow tasks. All unstandardized factor loadings are fixed to 1. Residuals are omitted from the plot for simplicity. We used the same model structures also for threshold separation, non-decision time and mean logarithmized response times.

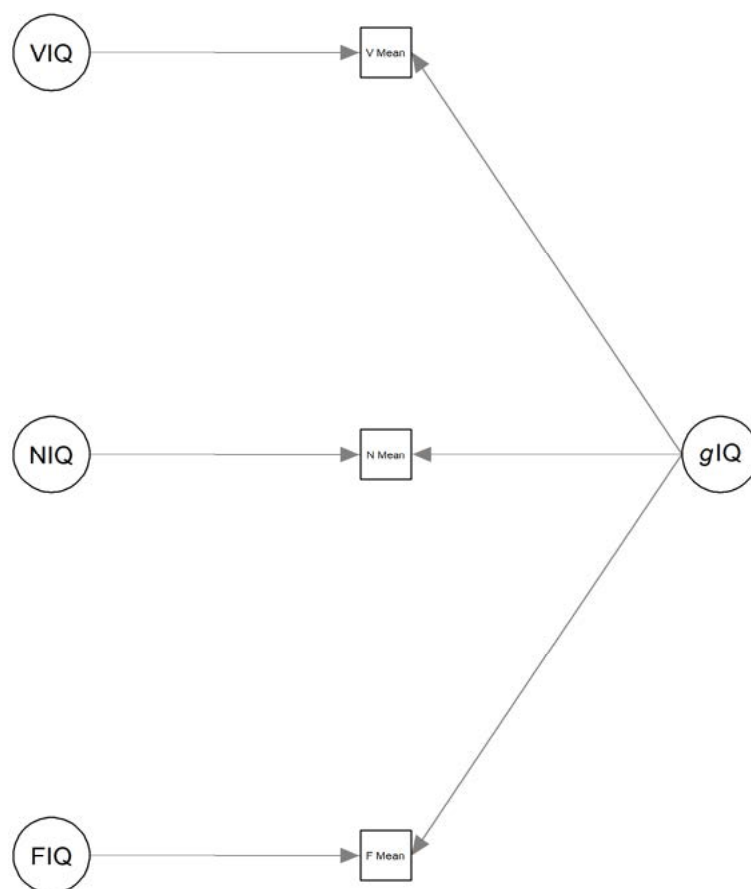

Figure 4. Intelligence Model. Scale means are used as indicators for verbal (*VIQ*), numeric (*NIQ*) and figural (*FIQ*) intelligence. *glQ* = general intelligence. Indicator residuals are fixed to zero, domain factors serve as quasi-residuals, see Methods.

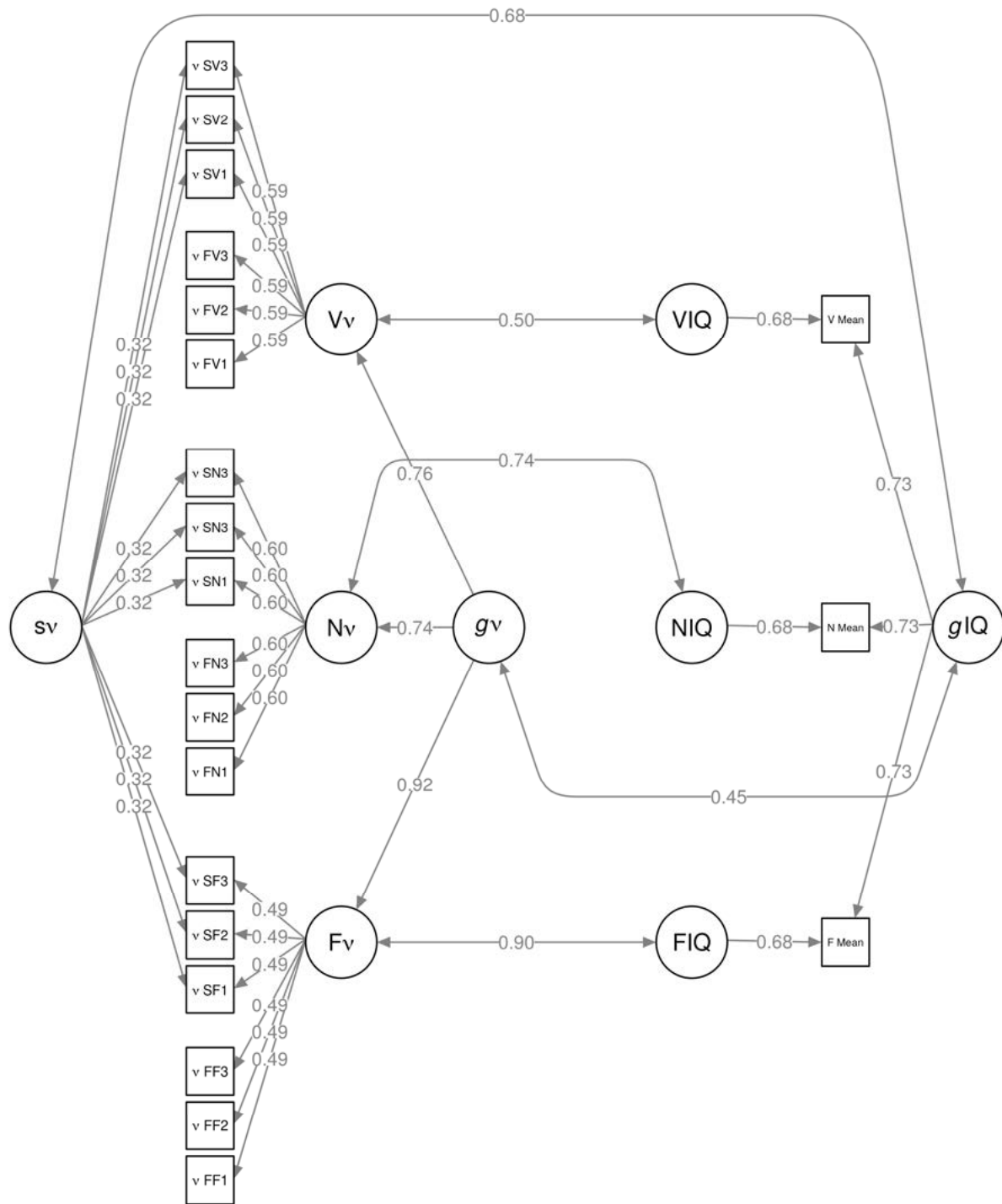

Figure 5. Combined Drift-Intelligence Model. The first letter of the task indices denotes the type of task (F = fast, S = slow); the second letter indicates the domain (N = numeric, V = verbal, F = figural). See Table 1 for a brief description of all tasks. Completely standardized loadings are reported. Residuals are omitted from the plot for simplicity. The latent correlations between the drift domains and intelligence domains are between the drift domain residuals and the (quasi-residual) intelligence domain factors (see Methods). g_v = general drift rate factor. V_v = verbal drift rate factor. N_v = numeric drift rate factor. F_v = figural drift rate factor. sv = method factor for drift rate in slow tasks. Scale means are used as indicators for verbal (VIQ), numeric (NIQ) and figural (FIQ) intelligence. gIQ = general intelligence. As the loadings of the drift domain factors are standardized on the different freely estimated variances of the domain factors, their standardized values differ although the unstandardized loadings are all fixed to 1.

References

- Arnold, N. R., Bröder, A., & Bayen, U. J. (2015). Empirical validation of the diffusion model for recognition memory and a comparison of parameter-estimation methods. *Psychological Research, 79*(5), 882-898. doi: 10.1007/s00426-014-0608-y
- Aschenbrenner, A. J., Balota, D. A., Gordon, B. A., Ratcliff, R., & Morris, J. C. (2016). A diffusion model analysis of episodic recognition in preclinical individuals with a family history for Alzheimer's disease: The adult children study. *Neuropsychology, 30*(2), 225-238. doi: 10.1037/neu0000222
- Barrouillet, P., Bernardin, S., & Camos, V. (2004). Time Constraints and Resource Sharing in Adults' Working Memory Spans. *Journal of Experimental Psychology: General, 133*(1), 83-100. doi: 10.1037/0096-3445.133.1.83
- Bock, O., Baetge, I., & Nicklisch, A. (2014). hroot: Hamburg registration and organization online tool. *European Economic Review, 71*, 117-120.
- Brown, S. D., & Heathcote, A. (2008). The simplest complete model of choice response time: Linear ballistic accumulation. *Cognitive Psychology, 57*(3), 153-178. doi: 10.1016/j.cogpsych.2007.12.002
- Camos, V., & Barrouillet, P. (2014). Attentional and non-attentional systems in the maintenance of verbal information in working memory: The executive and phonological loops. *Frontiers in Human Neuroscience, 8*. doi: 10.3389/fnhum.2014.00900
- Carpenter, P. A., Just, M. A., & Shell, P. (1990). What one intelligence test measures: A theoretical account of the processing in the Raven Progressive Matrices Test. *Psychological Review, 97*(3), 404-431. doi: 10.1037/0033-295X.97.3.404
- Carroll, J. B. (1993). *Human cognitive abilities: A survey of factor-analytic studies*. New York, NY, US: Cambridge University Press.
- Cattell, R. B., & Cattell, A. (1960). *Measuring intelligence with the culture fair tests*. Champaign, IL, USA: Institute for Personality and Ability Testing.
- Chuderski, A. (2013). When are fluid intelligence and working memory isomorphic and when are they not? *Intelligence, 41*(4), 244-262. doi: 10.1016/j.intell.2013.04.003
- Conway, A. R. A., & Kovacs, K. (2015). New and emerging models of human intelligence. *WIREs Cognitive Science, 6*(5), 419-426. doi: 10.1002/wcs.1356
- Coyle, T. R. (2003). A review of the worst performance rule: Evidence, theory, and alternative hypotheses. *Intelligence, 31*(6), 567-587. doi: 10.1016/S0160-2896(03)00054-0
- Coyle, T. R. (2017). A Differential-Developmental Model (DDM): Mental Speed, Attention Lapses, and General Intelligence (g). *Journal of Intelligence, 5*(2), 25.
- Cudeck, R. (1989). Analysis of correlation matrices using covariance structure models. *Psychological bulletin, 105*(2), 317-327. doi: 10.1037/0033-2909.105.2.317
- Deary, I. J., Lawn, M., & Bartholomew, D. J. (2008). A conversation between Charles Spearman, Godfrey Thomson, and Edward L Thorndike: The International Examinations Inquiry Meetings 1931-1938. *History of Psychology, 11*(2), 122-142. doi: 10.1037/1093-4510.11.2.122
- Detterman, D. K., & Daniel, M. H. (1989). Correlations of mental tests with each other and with cognitive variables are highest for low IQ groups. *Intelligence, 13*(4), 349-359. doi: [https://doi.org/10.1016/S0160-2896\(89\)80007-8](https://doi.org/10.1016/S0160-2896(89)80007-8)
- Dutilh, G., Vandekerckhove, J., Tuerlinckx, F., & Wagenmakers, E.-J. (2009). A diffusion model decomposition of the practice effect. *Psychonomic Bulletin & Review, 16*(6), 1026-1036. doi: 10.3758/16.6.1026
- Eid, M., Lischetzke, T., Nussbeck, F. W., & Trierweiler, L. I. (2003). Separating trait effects from trait-specific method effects in multitrait-multimethod models: A multiple-indicator CT-C(M-1) model. *Psychological Methods, 8*(1), 38-60. doi: 10.1037/1082-989X.8.1.38
- Frischkorn, G. T., & Schubert, A.-L. (2018). Cognitive Models in Intelligence Research: Advantages and Recommendations for Their Application. *Journal of Intelligence, 6*(3), 34.
- Frischkorn, G. T., Schubert, A.-L., Neubauer, A. B., & Hagemann, D. (2016). The Worst Performance Rule as Moderation: New Methods for Worst Performance Analysis. *Journal of Intelligence, 4*(3), 9.
- Germar, M., Schlemmer, A., Krug, K., Voss, A., & Mojzisch, A. (2014). Social influence and perceptual decision making: A diffusion model analysis. *Personality and Social Psychology Bulletin, 40*(2), 217-231. doi: 10.1177/0146167213508985
- Gignac, G. E. (2016). The higher-order model imposes a proportionality constraint: That is why the bifactor model tends to fit better. *Intelligence, 55*, 57-68. doi: 10.1016/j.intell.2016.01.006
- Hawkins, G. E., Hayes, B. K., & Heit, E. (2016). A dynamic model of reasoning and memory. *Journal of Experimental Psychology: General, 145*(2), 155-180. doi: 10.1037/xge0000113
- Horn, J. L. (1965). A rationale and test for the number of factors in factor analysis. *psychometrika, 30*(2), 179-185. doi: 10.1007/bf02289447
- Hu, L.-t., & Bentler, P. M. (1999). Cutoff criteria for fit indexes in covariance structure analysis: Conventional criteria versus new alternatives. *Structural Equation Modeling, 6*(1), 1-55. doi: 10.1080/10705519909540118
- Jäger, A. O. (1982). Mehrmodale Klassifikation von Intelligenzleistungen: Experimentell kontrollierte Weiterentwicklung eines deskriptiven Intelligenzstrukturmodells. = Multimodal classification of intelligence achievement: Experimentally controlled, further development of a descriptive intelligence structure model. *Diagnostica, 28*(3), 195-225.

- Jäger, A. O., Süß, H.-M., & Beauducel, A. (1997). *Berliner Intelligenzstruktur-Test : BIS-Test, Form 4*. Göttingen [u.a.]: Hogrefe.
- Jensen, A. R. (1987). Process differences and individual differences in some cognitive tasks. *Intelligence*, *11*(2), 107-136. doi: 10.1016/0160-2896(87)90001-8
- Jensen, A. R. (2005). Mental chronometry and the unification of differential psychology. In R. J. Sternberg & J. E. Pretz (Eds.), *Cognition and intelligence: Identifying the mechanisms of the mind*. (pp. 26-50). New York, NY: Cambridge University Press.
- Jensen, A. R. (2006). *Clocking the Mind: Mental Chronometry and Individual Differences*. Amsterdam: Elsevier.
- Kan, K.-J., van der Maas, H. L. J., & Kievit, R. A. (2016). Process overlap theory: Strengths, limitations, and challenges. *Psychological inquiry*, *27*(3), 220-228. doi: 10.1080/1047840X.2016.1182000
- Kan, K.-J., van der Maas, H. L. J., & Levine, S. Z. (2019). Extending psychometric network analysis: Empirical evidence against g in favor of mutualism? *Intelligence*, *73*, 52-62. doi: 10.1016/j.intell.2018.12.004
- Kim, K. H. (2005). The Relation Among Fit Indexes, Power, and Sample Size in Structural Equation Modeling. *Structural Equation Modeling*, *12*(3), 368-390. doi: 10.1207/s15328007sem1203_2
- Kovacs, K., & Conway, A. R. A. (2016). Process overlap theory: A unified account of the general factor of intelligence. *Psychological inquiry*, *27*(3), 151-177. doi: 10.1080/1047840X.2016.1153946
- Larsen, L., Hartmann, P., & Nyborg, H. (2008). The stability of general intelligence from early adulthood to middle-age. *Intelligence*, *36*(1), 29-34. doi: 10.1016/j.intell.2007.01.001
- Larson, G. E., & Alderton, D. L. (1990). Reaction time variability and intelligence: A "worst performance" analysis of individual differences. *Intelligence*, *14*(3), 309-325. doi: [https://doi.org/10.1016/0160-2896\(90\)90021-K](https://doi.org/10.1016/0160-2896(90)90021-K)
- Lerche, V., Christmann, U., & Voss, A. (2018). Impact of context information on metaphor elaboration: A diffusion model study. *Experimental Psychology*, *65*(6), 370-384. doi: 10.1027/1618-3169/a000422
- Lerche, V., & Voss, A. (2016). Model complexity in diffusion modeling: Benefits of making the model more parsimonious. *Frontiers in Psychology*, *7*(1324). doi: 10.3389/fpsyg.2016.01324
- Lerche, V., & Voss, A. (2017a). Experimental Validation of the Diffusion Model based on a Slow Response Time Paradigm. *Psychological Research*. doi: 10.1007/s00426-017-0945-8
- Lerche, V., & Voss, A. (2017b). Retest reliability of the parameters of the Ratcliff diffusion model. *Psychological Research*, *81*(3), 629-652. doi: 10.1007/s00426-016-0770-5
- Lerche, V., Voss, A., & Nagler, M. (2017). How many trials are required for parameter estimation in diffusion modeling? A comparison of different optimization criteria. *Behavior Research Methods*, *49*(2), 513-537. doi: 10.3758/s13428-016-0740-2
- Levine, G., Preddy, D., & Thorndike, R. L. (1987). Speed of information processing and level of cognitive ability. *Personality and individual differences*, *8*(5), 599-607. doi: 10.1016/0191-8869(87)90057-2
- Lindley, R. H., Wilson, S. M., Smith, W. R., & Bathurst, K. (1995). Reaction time (RT) and IQ: Shape of the task complexity function. *Personality and individual differences*, *18*(3), 339-345. doi: 10.1016/0191-8869(94)00154-K
- Lord, F. M., & Novick, M. R. (1968). *Statistical theories of mental test scores*. Reading MA: Addison-Wesley.
- Marshalek, B., Lohman, D. F., & Snow, R. E. (1983). The complexity continuum in the radex and hierarchical models of intelligence. *Intelligence*, *7*(2), 107-127. doi: 10.1016/0160-2896(83)90023-5
- McKoon, G., & Ratcliff, R. (2012). Aging and IQ effects on associative recognition and priming in item recognition. *Journal of Memory and Language*, *66*(3), 416-437. doi: 10.1016/j.jml.2011.12.001
- Morgan, G. B., Hodge, K. J., Wells, K. E., & Watkins, M. W. (2015). Are Fit Indices Biased in Favor of Bi-Factor Models in Cognitive Ability Research?: A Comparison of Fit in Correlated Factors, Higher-Order, and Bi-Factor Models via Monte Carlo Simulations. *Journal of Intelligence*, *3*(1), 2-20.
- Neubauer, A. C., & Bucik, V. (1996). The mental speed—IQ relationship: unitary or modular? *Intelligence*, *22*(1), 23-48. doi: [https://doi.org/10.1016/S0160-2896\(96\)90019-7](https://doi.org/10.1016/S0160-2896(96)90019-7)
- Partchev, I., & De Boeck, P. (2012). Can fast and slow intelligence be differentiated? *Intelligence*, *40*(1), 23-32. doi: 10.1016/j.intell.2011.11.002
- Petrov, A. A., Van Horn, N. M., & Ratcliff, R. (2011). Dissociable perceptual-learning mechanisms revealed by diffusion-model analysis. *Psychonomic Bulletin & Review*, *18*(3), 490-497. doi: 10.3758/s13423-011-0079-8
- Ratcliff, R. (1978). A theory of memory retrieval. *Psychological Review*, *85*(2), 59-108. doi: 10.1037/0033-295x.85.2.59
- Ratcliff, R. (2014). Measuring psychometric functions with the diffusion model. *Journal of Experimental Psychology: Human Perception and Performance*, *40*(2), 870-888. doi: 10.1037/a0034954
- Ratcliff, R., & Childers, R. (2015). Individual differences and fitting methods for the two-choice diffusion model of decision making. *Decision*, *2*(4), 237-279. doi: 10.1037/dec0000030
- Ratcliff, R., & Frank, M. J. (2012). Reinforcement-Based Decision Making in Corticostriatal Circuits: Mutual Constraints by Neurocomputational and Diffusion Models. *Neural Computation*, *24*(5), 1186-1229. doi: 10.1162/NECO_a_00270
- Ratcliff, R., Gomez, P., & McKoon, G. (2004). A Diffusion Model Account of the Lexical Decision Task. *Psychological Review*, *111*(1), 159-182. doi: 10.1037/0033-295x.111.1.159
- Ratcliff, R., & McKoon, G. (2008). The diffusion decision model: Theory and data for two-choice decision tasks. *Neural Computation*, *20*(4), 873-922. doi: 10.1162/neco.2008.12-06-420
- Ratcliff, R., & Rouder, J. N. (1998). Modeling response times for two-choice decisions. *Psychological Science*, *9*(5), 347-356. doi: 10.1111/1467-9280.00067

- Ratcliff, R., Smith, P. L., Brown, S. D., & McKoon, G. (2016). Diffusion decision model: Current issues and history. *Trends in cognitive sciences*, 20(4), 260-281. doi: 10.1016/j.tics.2016.01.007
- Ratcliff, R., Thapar, A., Gomez, P., & McKoon, G. (2004). A diffusion model analysis of the effects of aging in the lexical-decision task. *Psychology and Aging*, 19(2), 278. doi: 10.1037/0882-7974.19.2.278
- Ratcliff, R., Thapar, A., & McKoon, G. (2010). Individual differences, aging, and IQ in two-choice tasks. *Cognitive Psychology*, 60(3), 127-157. doi: 10.1016/j.cogpsych.2009.09.001
- Ratcliff, R., Thapar, A., & McKoon, G. (2011). Effects of aging and IQ on item and associative memory. *Journal of Experimental Psychology: General*, 140(3), 464-487. doi: 10.1037/a0023810
- Ratcliff, R., Thompson, C. A., & McKoon, G. (2015). Modeling individual differences in response time and accuracy in numeracy. *Cognition*, 137, 115-136. doi: 10.1016/j.cognition.2014.12.004
- Ratcliff, R., & Tuerlinckx, F. (2002). Estimating parameters of the diffusion model: Approaches to dealing with contaminant reaction times and parameter variability. *Psychonomic Bulletin & Review*, 9(3), 438-481. doi: 10.3758/bf03196302
- Rosseel, Y. (2012). lavaan: An R Package for Structural Equation Modeling. 2012, 48(2), 36. doi: 10.18637/jss.v048.i02
- Salthouse, T. A. (1996). The processing-speed theory of adult age differences in cognition. *Psychological Review*, 103(3), 403-428. doi: 10.1037/0033-295X.103.3.403
- Scheithe, K., & Bäuml, K.-H. (1995). Deutschsprachige Normen für Vertreter von 48 Kategorien. = German-language norms for representatives of 48 conceptual categories. *Sprache & Kognition*, 14(1), 39-43.
- Schmiedek, F., Oberauer, K., Wilhelm, O., Süß, H.-M., & Wittmann, W. W. (2007). Individual differences in components of reaction time distributions and their relations to working memory and intelligence. *Journal of Experimental Psychology - General*, 136(3), 414-429. doi: 10.1037/0096-3445.136.3.414
- Schmitz, F., & Voss, A. (2012). Decomposing task-switching costs with the diffusion model. *Journal of Experimental Psychology: Human Perception and Performance*, 38(1), 222-250. doi: 10.1037/a0026003
- Schmitz, F., & Wilhelm, O. (2016). Modeling Mental Speed: Decomposing Response Time Distributions in Elementary Cognitive Tasks and Correlations with Working Memory Capacity and Fluid Intelligence. *Journal of Intelligence*, 4(4), 13.
- Schubert, A.-L. (2019). A meta-analysis of the worst performance rule. *Intelligence*, 73, 88-100. doi: 10.1016/j.intell.2019.02.003
- Schubert, A.-L., Frischkorn, G. T., Hagemann, D., & Voss, A. (2016). Trait Characteristics of Diffusion Model Parameters. *Journal of Intelligence*, 4(3), 7. doi: 10.3390/jintelligence4030007
- Schubert, A.-L., Hagemann, D., Frischkorn, G. T., & Herpertz, S. C. (2018). Faster, but not smarter: An experimental analysis of the relationship between mental speed and mental abilities. *Intelligence*, 71, 66-75. doi: <https://doi.org/10.1016/j.intell.2018.10.005>
- Schubert, A.-L., Hagemann, D., Voss, A., Schankin, A., & Bergmann, K. (2015). Decomposing the relationship between mental speed and mental abilities. *Intelligence*, 51, 28-46. doi: 10.1016/j.intell.2015.05.002
- Schubert, A.-L., & Rey-Mermet, A. (2019). Does Process Overlap Theory Replace the Issues of General Intelligence with the Issues of Attentional Control? *Journal of Applied Research in Memory and Cognition*, 8(3), 277-283. doi: <https://doi.org/10.1016/j.jarmac.2019.06.004>
- Schulz-Zhecheva, Y., Voelkle, M., Beauducel, A., Biscaldi, M., & Klein, C. (2016). Predicting Fluid Intelligence by Components of Reaction Time Distributions from Simple Choice Reaction Time Tasks. *Journal of Intelligence*, 4(3), 8. doi: 10.3390/jintelligence4030008
- Sheppard, L. D., & Vernon, P. A. (2008). Intelligence and speed of information-processing: A review of 50 years of research. *Personality and individual differences*, 44(3), 535-551. doi: 10.1016/j.paid.2007.09.015
- Spaniol, J., Madden, D. J., & Voss, A. (2006). A Diffusion Model Analysis of Adult Age Differences in Episodic and Semantic Long-Term Memory Retrieval. *Journal of Experimental Psychology: Learning, Memory, and Cognition*, 32(1), 101-117. doi: 10.1037/0278-7393.32.1.101
- Theisen, M., Lerche, V., von Krause, M., & Voss, A. (2019). Age differences in diffusion model parameters: A meta-analysis. *Manuscript submitted for publication*.
- Thomson, G. H. (1916). A Hierarchy without a General Factor. *British Journal of Psychology*, 8(3), 271.
- Tukey, J. W. (1977). *Exploratory Data Analysis*. Reading: Addison-Wesley.
- van Ravenzwaaij, D., Donkin, C., & Vandekerckhove, J. (2016). The EZ diffusion model provides a powerful test of simple empirical effects. *Psychonomic Bulletin & Review*, 1-10. doi: 10.3758/s13423-016-1081-y
- van Ravenzwaaij, D., Donkin, C., & Vandekerckhove, J. (2017). The EZ diffusion model provides a powerful test of simple empirical effects. *Psychonomic Bulletin & Review*, 24(2), 547-556. doi: 10.3758/s13423-016-1081-y
- Voss, A., Nagler, M., & Lerche, V. (2013). Diffusion models in experimental psychology: A practical introduction. *Experimental Psychology*, 60(6), 385-402. doi: 10.1027/1618-3169/a000218
- Voss, A., Rothermund, K., Gast, A., & Wentura, D. (2013). Cognitive processes in associative and categorical priming: a diffusion model analysis. *J Exp Psychol Gen*, 142(2), 536-559. doi: 10.1037/a0029459
- Voss, A., Rothermund, K., & Voss, J. (2004). Interpreting the parameters of the diffusion model: An empirical validation. *Memory & Cognition*, 32(7), 1206-1220. doi: 10.3758/BF03196893
- Voss, A., & Voss, J. (2007). Fast-dm: A free program for efficient diffusion model analysis. *Behavior Research Methods*, 39(4), 767-775. doi: 10.3758/bf03192967

- Voss, A., & Voss, J. (2008). A fast numerical algorithm for the estimation of diffusion model parameters. *Journal of Mathematical Psychology*, 52(1), 1-9. doi: 10.1016/j.jmp.2007.09.005
- Voss, A., Voss, J., & Lerche, V. (2015). Assessing cognitive processes with diffusion model analyses: a tutorial based on fast-dm-30. *Frontiers in Psychology*, 6(336). doi: 10.3389/fpsyg.2015.00336
- Wagenmakers, E.-J. (2009). Methodological and empirical developments for the Ratcliff diffusion model of response times and accuracy. *European Journal of Cognitive Psychology*, 21(5), 641-671. doi: 10.1080/09541440802205067
- Wagenmakers, E.-J., Ratcliff, R., Gomez, P., & McKoon, G. (2008). A diffusion model account of criterion shifts in the lexical decision task. *Journal of Memory and Language*, 58(1), 140-159. doi: 10.1016/j.jml.2007.04.006
- Weiss, R. H. (2006). *Grundintelligenztest Skala 2-Revidierte Fassung (CFT 20-R)[General Intelligence Test Scale 2-Revised]*. Göttingen: Hogrefe.
- White, C. N., Curl, R. A., & Sloane, J. F. (2016). Using Decision Models to Enhance Investigations of Individual Differences in Cognitive Neuroscience. *Frontiers in Psychology*, 7(81). doi: 10.3389/fpsyg.2016.00081
- Wilhelm, O., Schroeders, U., & Schipolowski, S. (2014). *Berliner Test zur Erfassung fluider und kristalliner Intelligenz für die 8. bis 10. Jahrgangsstufe (BEFKI 8-10)*. Göttingen: Hogrefe.
- Yap, M. J., Balota, D. A., Sibley, D. E., & Ratcliff, R. (2012). Individual differences in visual word recognition: Insights from the English Lexicon Project. *Journal of Experimental Psychology: Human Perception and Performance*, 38(1), 53-79. doi: 10.1037/a0024177

Appendix A: Task Descriptives

Table A1

Descriptives of RT (in ms)

Task	Mean	<i>SD</i>	Minimum	Maximum
FF1	560	96	398	846
FF2	620	176	372	1,278
FF3	551	96	393	877
FN1	527	78	395	758
FN2	590	107	409	947
FN3	670	135	467	1,168
FV1	792	164	542	1,350
FV2	781	162	513	1,397
FV3	737	124	530	1,161
SF1	3,234	1,091	1,517	7,354
SF2	4,189	2,009	1,355	10,366
SF3	2,856	906	1,021	5,171
SN1	4,168	1,904	1,004	11,074
SN2	2,761	1,098	1,014	6,670
SN3	2,805	885	1,571	5,780
SV1	2,380	709	1,145	4,516
SV2	3,030	1,002	1,654	6,599
SV3	3,600	895	1,935	6,808

Note. The first letter indicates the task complexity (F = fast, S = slow); the second letter denotes the domain (N = numeric, V = verbal, F = figural). See Table 1 for a brief description of all tasks. *SD* = standard deviation.

Table A2
Descriptives of Accuracy Rate (in %)

Task	Mean	<i>SD</i>	Minimum	Maximum
FF1	93.65	2.88	84.54	97.00
FF2	98.68	1.60	93.00	100.00
FF3	97.71	1.90	91.58	100.00
FN1	98.03	2.26	89.00	100.00
FN2	97.68	2.03	91.00	100.00
FN3	97.17	2.74	88.00	100.00
FV1	96.22	3.76	79.55	100.00
FV2	95.11	3.97	78.35	100.00
FV3	97.18	2.41	87.00	100.00
SF1	95.53	2.91	87.00	100.00
SF2	86.69	6.50	69.00	100.00
SF3	80.47	9.10	53.06	97.00
SN1	90.76	8.11	61.00	100.00
SN2	91.16	5.48	72.00	98.00
SN3	93.51	3.71	82.00	100.00
SV1	96.36	2.39	88.00	100.00
SV2	95.11	2.61	85.86	99.00
SV3	94.24	4.77	80.21	100.00

Note. The first letter indicates the task complexity (F = fast, S = slow); the second letter denotes the domain (N = numeric, V = verbal, F = figural). See Table 1 for a brief description of all tasks. *SD* = standard deviation.

Table A3
Descriptives of drift rate

Task	Mean	<i>SD</i>	Minimum	Maximum
FF1	3.16	0.73	1.79	6.42
FF2	3.26	1.02	1.43	7.16
FF3	4.27	0.96	2.38	8.01
FN1	4.97	1.82	2.41	16.50
FN2	3.95	0.97	2.12	8.52
FN3	3.97	1.39	2.00	12.23
FV1	2.81	0.88	1.37	6.25
FV2	2.68	0.78	1.12	4.83
FV3	3.21	0.89	1.54	6.61
SF1	0.94	0.20	0.52	1.61
SF2	0.58	0.17	0.17	0.97
SF3	0.50	0.18	0.09	1.02
SN1	0.70	0.22	0.15	1.30
SN2	0.80	0.25	0.39	1.48
SN3	1.08	0.33	0.57	2.15
SV1	1.17	0.20	0.64	1.79
SV2	1.03	0.29	0.54	1.99
SV3	0.90	0.23	0.39	1.63

Note. The first letter indicates the task complexity (F = fast, S = slow); the second letter denotes the domain (N = numeric, V = verbal, F = figural). See Table 1 for a brief description of all tasks. *SD* = standard deviation.

Table A4
Descriptives of threshold separation

Task	Mean	<i>SD</i>	Minimum	Maximum
FF1	0.91	0.21	0.46	1.71
FF2	1.53	0.53	0.66	3.61
FF3	1.16	0.61	0.63	5.52
FN1	1.47	1.31	0.44	10.00
FN2	1.20	0.51	0.62	3.90
FN3	1.36	1.03	0.50	10.00
FV1	1.52	0.73	0.53	5.76
FV2	1.33	0.44	0.55	2.62
FV3	1.35	0.55	0.66	5.61
SF1	3.75	1.44	1.73	10.00
SF2	3.71	1.37	1.45	8.05
SF3	3.06	0.81	1.36	5.10
SN1	4.00	1.53	1.21	10.00
SN2	3.25	0.92	1.13	6.35
SN3	2.85	0.92	1.52	6.79
SV1	3.08	0.84	1.71	7.07
SV2	3.19	0.87	1.35	5.14
SV3	3.69	1.23	1.75	10.00

Note. The first letter indicates the task complexity (F = fast, S = slow); the second letter denotes the domain (N = numeric, V = verbal, F = figural). See Table 1 for a brief description of all tasks. *SD* = standard deviation.

Table A5
Descriptives of non-decision time (in ms)

Task	Mean	<i>SD</i>	Minimum	Maximum
FF1	423	65	273	587
FF2	359	66	242	592
FF3	411	56	236	555
FN1	388	67	135	539
FN2	427	57	313	678
FN3	499	96	192	789
FV1	513	76	226	850
FV2	527	74	367	749
FV3	520	65	333	732
SF1	1,286	495	137	2,969
SF2	1,480	918	63	5,874
SF3	913	397	230	2,657
SN1	1,628	1,207	0	5,794
SN2	844	309	36	2,097
SN3	1,501	422	628	2,983
SV1	1,092	348	366	2,525
SV2	1,448	420	910	3,746
SV3	1,635	413	68	3,280

Note. The first letter indicates the task complexity (F = fast, S = slow); the second letter denotes the domain (N = numeric, V = verbal, F = figural). See Table 1 for a brief description of all tasks. *SD* = standard deviation.

Table A6

Descriptives of BIS domain scale scores

	Mean	<i>SD</i>	Minimum	Maximum
F_Mean	96.35	7.74	76.50	114.25
N_Mean	99.94	8.38	80.50	120.75
V_Mean	102.78	7.83	79.75	121.50

Note. V = Verbal, N = Numeric, F = Figural. *SD* = standard deviation.

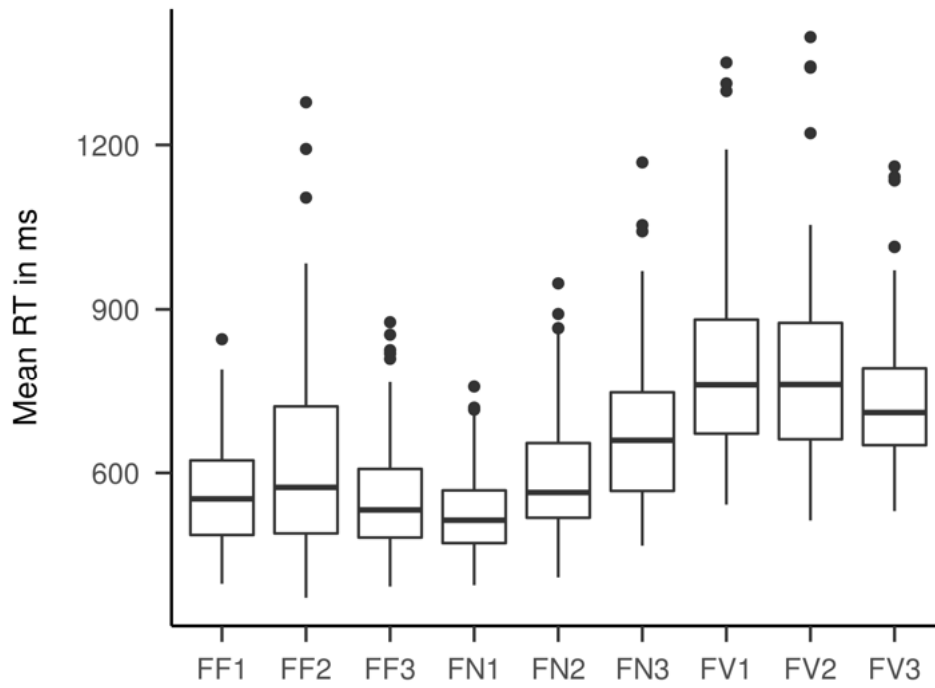

Figure A1. Boxplots of mean response times for all *fast* tasks. The first letter indicates the task complexity (F = fast); the second letter denotes the domain (N = numeric, V = verbal, F = figural). See Table 1 for a brief description of all tasks. The boxplots display the first, second and third quartile. Outliers are values greater than 1.5 times the interquartile range from either end of the box.

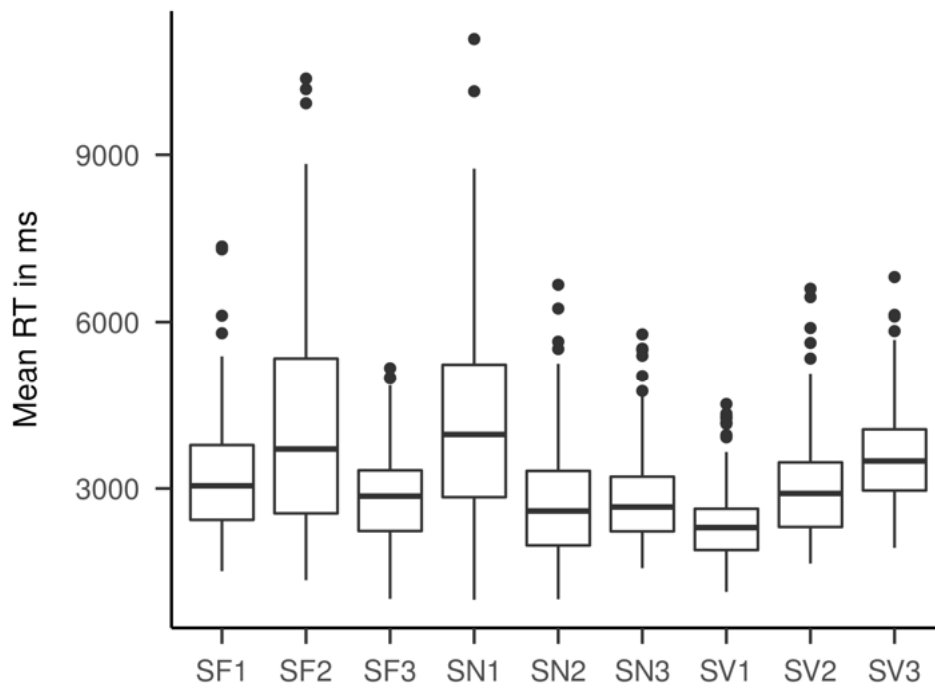

Figure A2. Boxplots of mean response times for all *slow* tasks. The first letter indicates the task complexity (S = slow); the second letter denotes the domain (N = numeric, V = verbal, F = figural). See Table 1 for a brief description of all tasks. The boxplots display the first, second and third quartile. Outliers are values greater than 1.5 times the interquartile range from either end of the box.

Appendix B: Diffusion Model Fit

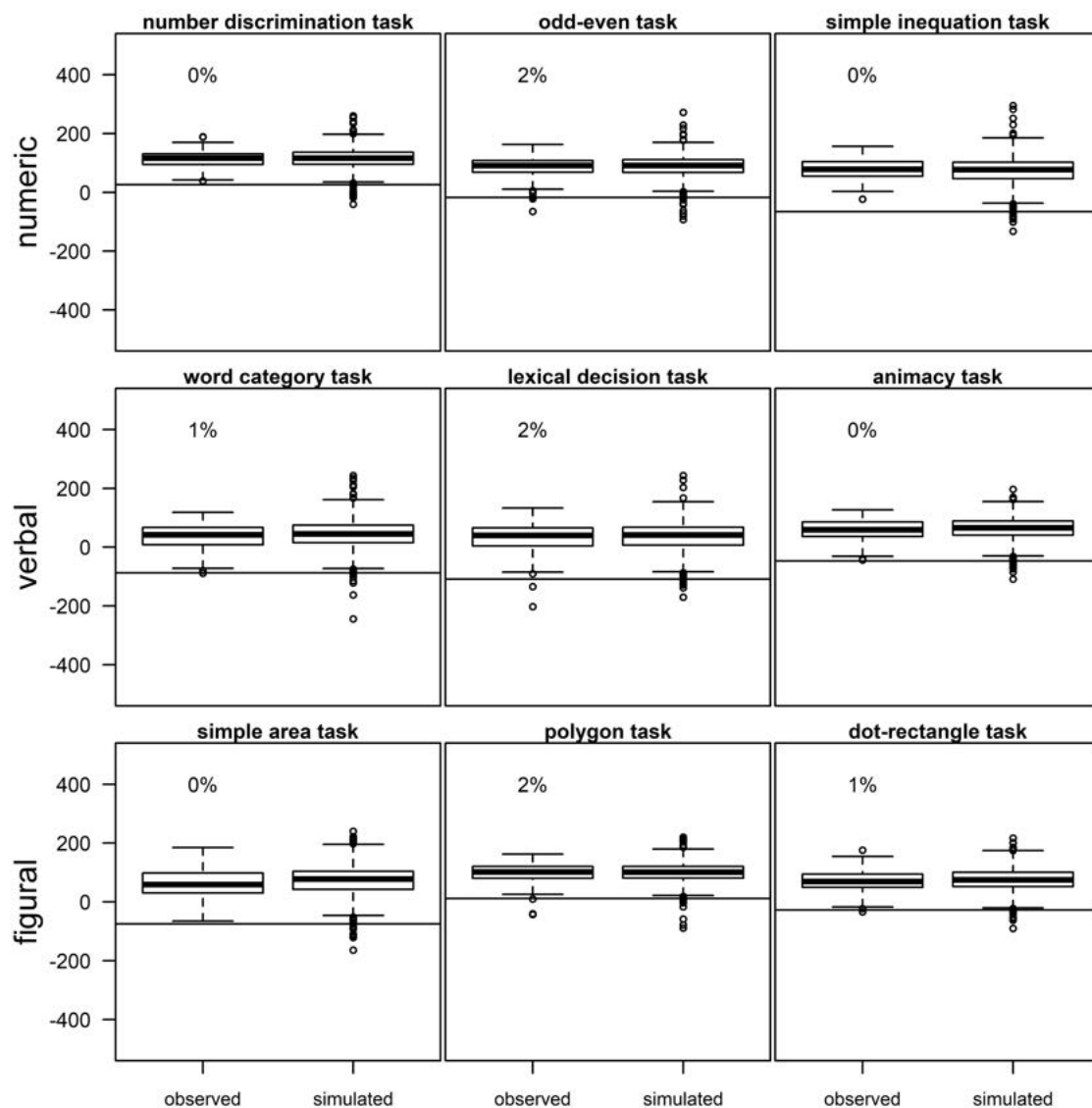

Figure B1. Model fit of all *fast* RT tasks. The boxplots show the maximum likelihood statistic (sum of logarithmized densities). Lower values indicate worse model fit. The horizontal line is the 1% percentile of fit values from 1000 simulated data sets. For observed data, the percentage of fits that are worse than this critical value is also given.

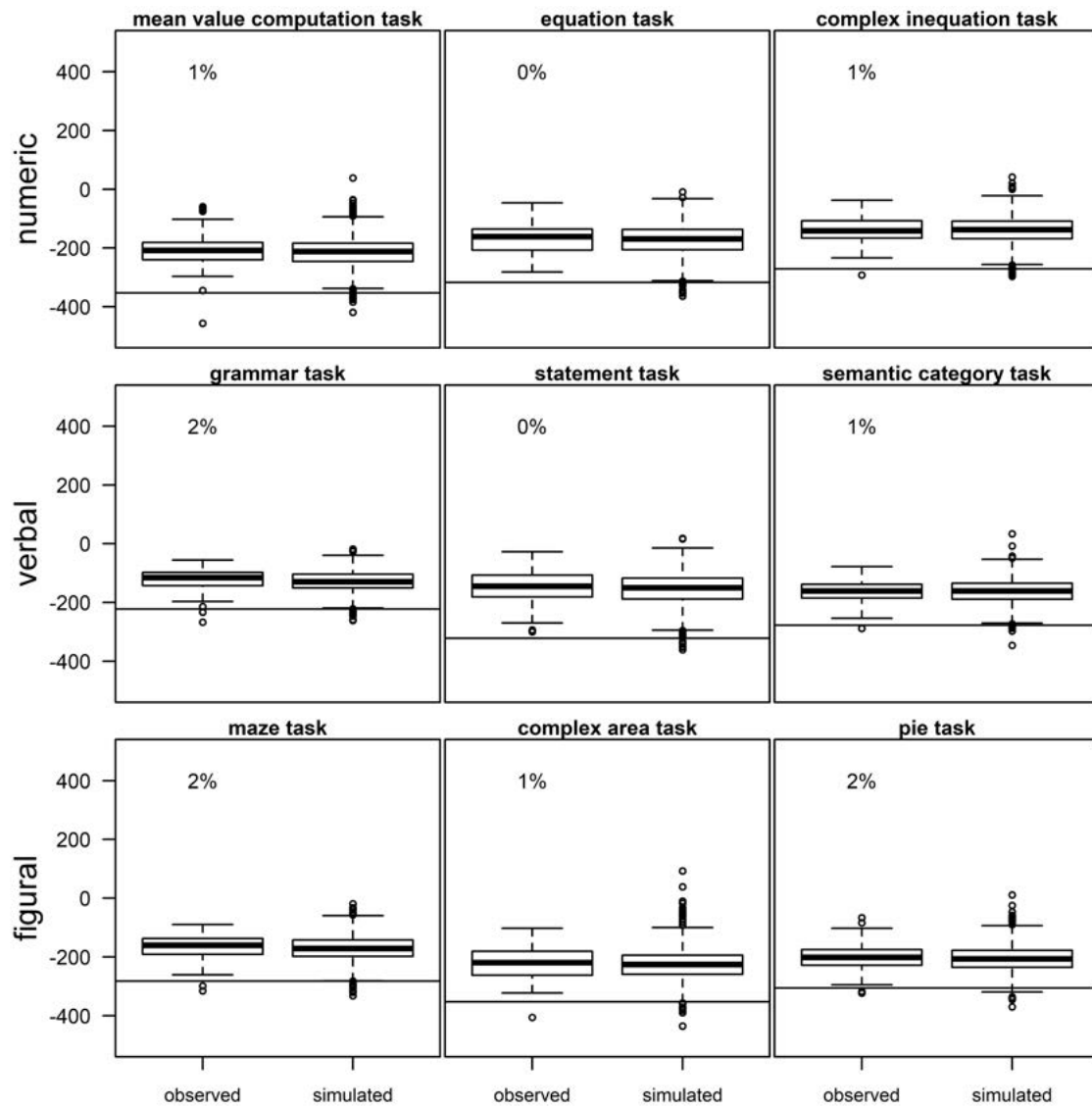

Figure B2. Model fit of all *slow* RT tasks. The boxplots show the maximum likelihood statistic (sum of logarithmized densities). Lower values indicate worse model fit. The horizontal line is the 1% percentile of fit values from 1000 simulated data sets. For observed data, the percentage of fits that are worse than this critical value is also given.

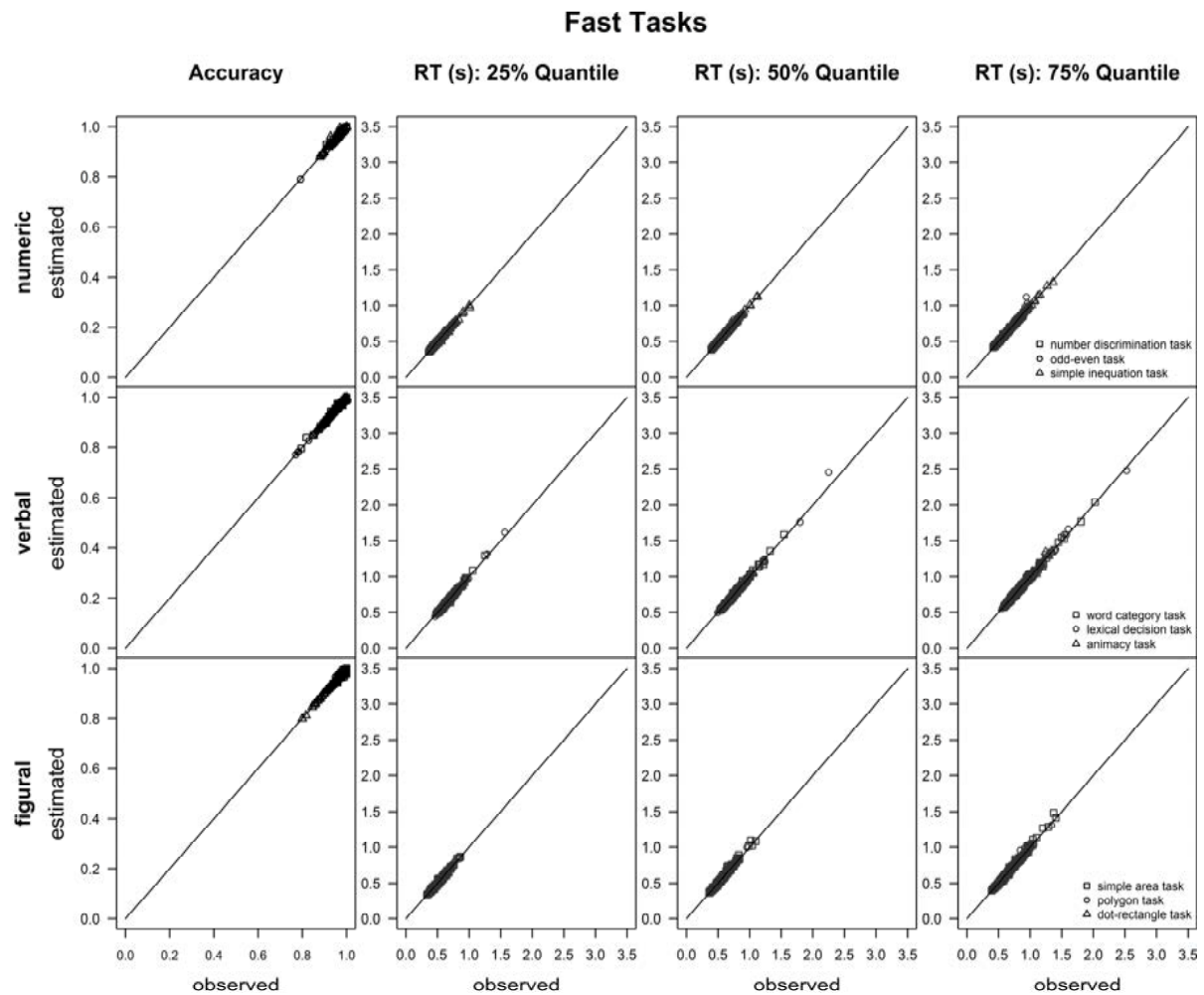

Figure B3. Model fit of the *fast* RT tasks based on the comparison of statistics (accuracy rate, first, second and third RT quartile) of observed data and models' predictions. Each point represents one participant in one task. The diagonals indicate perfect model fit. One data point exceeding the scales of the third RT quartile plot was omitted.

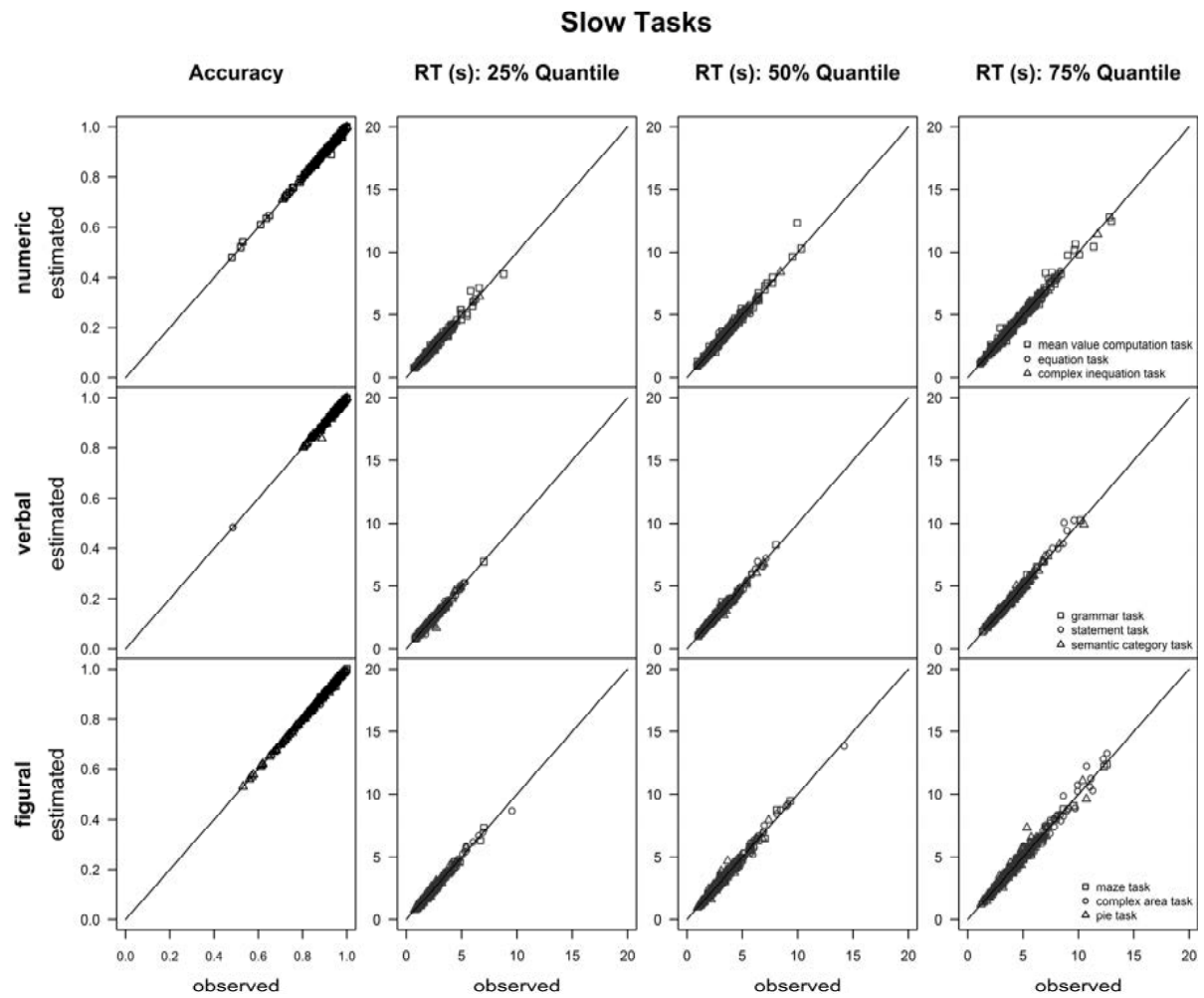

Figure B4. Model fit of the *slow* RT tasks based on the comparison of statistics (accuracy rate, first, second and third RT quartile) of observed data and models' predictions. Each point represents one participant in one task. The diagonals indicate perfect model fit. Two data points exceeding the scales of the third RT quartile plot were omitted.

Appendix C: Structural Equation Models

Table C1

Drift Model 1 (g factor)

Parameter	Estimate	SE	95% CI	<i>p</i>	Std. Est.
Loadings					
gv on v (each task)	1	0			0.509
Latent (Residual) Variances					
gv	0.259	0.020	[0.219; 0.298]	<.001	1
Residual Indicator Variances					
v (each task)	0.741	0.020	[0.702; 0.781]	<.001	0.741

Note. Missing *p* values indicate fixed parameters. The standardized solution is completely standardized.

Table C2
Drift Model 2 (uncorrelated domains)

Parameter	Estimate	<i>SE</i>	95% <i>CI</i>	<i>p</i>	Std. Est.
Loadings					
Fv on v (each figural task)	1	0			0.506
Nv on v (each numeric task)	1	0			0.610
Vv on v (each verbal task)	1	0			0.615
Latent (Residual) Variances					
Fv	0.256	0.035	[0.188; 0.325]	<.001	1
Nv	0.371	0.033	[0.308; 0.435]	<.001	1
Vv	0.378	0.033	[0.314; 0.442]	<.001	1
Residual Indicator Variances					
v (each figural task)	0.744	0.035	[0.675; 0.812]	<.001	0.744
v (each numeric task)	0.629	0.033	[0.565; 0.692]	<.001	0.629
v (each verbal task)	0.622	0.033	[0.558; 0.686]	<.001	0.622

Note. Missing *p* values indicate fixed parameters. The standardized solution is completely standardized.

Table C3
Drift Model 3 (hierarchical model of domains & g factor)

Parameter	Estimate	SE	95% CI	<i>p</i>	Std. Est.
Loadings					
Fv on v (each figural task)	1	0			0.514
Nv on v (each numeric task)	1	0			0.605
Vv on v (each verbal task)	1	0			0.617
gv on Fv	1	0			0.922
gv on Nv	1	0			0.784
gv on Vv	1	0			0.769
Latent (Residual) Variances					
gv	0.225	0.024	[0.178; 0.271]	<.001	1
Fv	0.039	0.029	[-0.017; 0.096]	.171	0.149
Nv	0.141	0.033	[0.077; 0.206]	<.001	0.386
Vv	0.156	0.032	[0.092; 0.219]	<.001	0.409
Residual Indicator Variances					
v (each figural task)	0.736	0.032	[0.672; 0.800]	<.001	0.736
v (each numeric task)	0.634	0.031	[0.573; 0.696]	<.001	0.634
v (each verbal task)	0.620	0.031	[0.559; 0.680]	<.001	0.620

Note. Missing *p* values indicate fixed parameters. The standardized solution is completely standardized.

Table C5
Intelligence Model

Parameter	Estimate	SE	95% CI	<i>p</i>	Std. Est.
Loadings					
gIQ on F_Mean/N_Mean/V_Mean	1	0			0.736
VIQ on V_Mean/NIQ on N_Mean/FIQ on F_Mean	1	0			0.677
Latent (Residual) Variances					
gIQ	0.542	0.040	[0.465; 0.620]	<.001	1
FIQ/NIQ/VIQ	0.458	0.040	[0.380; 0.535]	<.001	1
V_Mean/N_Mean/F_Mean	0	0			

Note. Missing *p* values indicate fixed parameters. The standardized solution is completely standardized.

Table C6

Drift Model 4 (hierarchical model of domains & g factor & slow method factor), freely estimated

Parameter	Estimate	SE	95% CI	p	Std. Est.
Loadings					
Fv on v.FF1	1	0			0.365
on v.FF2	1.213	0.685	[-0.128; 2.555]	.076	0.443
on v.FF3	1.996	1.266	[-0.486; 4.477]	.115	0.729
on v.SF1	0.793	0.624	[-0.430; 2.017]	.204	0.290
on v.SF2	0.974	0.532	[-0.067; 2.016]	.067	0.356
on v.SF3	1.364	0.802	[-0.207; 2.935]	.089	0.498
Nv on v.FN1	1	0			0.610
on v.FN2	1.035	0.144	[0.753; 1.318]	<.001	0.632
on v.FN3	0.802	0.158	[0.492; 1.112]	<.001	0.489
on v.SN1	0.673	0.188	[0.304; 1.042]	<.001	0.411
on v.SN2	1.172	0.203	[0.774; 1.570]	<.001	0.715
on v.SN3	1.206	0.217	[0.780; 1.632]	<.001	0.736
Vv on v.FV1	1	0			0.690
on v.FV2	1.045	0.126	[0.799; 1.291]	<.001	0.721
on v.FV3	0.942	0.135	[0.678; 1.207]	<.001	0.650
on v.SV1	0.828	0.123	[0.586; 1.070]	<.001	0.571
on v.SV2	0.628	0.130	[0.372; 0.883]	<.001	0.433
on v.SV3	0.741	0.136	[0.474; 1.008]	<.001	0.511
sv on v.SF1	1	0			0.378
on v.SF2	1.339	1.182	[-0.978; 3.656]	.257	0.507
on v.SF3	1.080	0.997	[-0.875; 3.034]	.279	0.408
on v.SN1	1.543	1.299	[-1.002; 4.088]	.235	0.584
on v.SN2	0.587	0.673	[-0.733; 1.907]	.383	0.222
on v.SN3	0.579	0.744	[-0.879; 2.038]	.436	0.219
on v.SV1	0.749	0.501	[-0.233; 1.731]	.135	0.283
on v.SV2	0.895	0.653	[-0.385; 2.175]	.170	0.339
on v.SV3	1.099	0.654	[-0.182; 2.381]	.093	0.416
gv on Fv	1	0			0.748
gv on Nv	1.860	1.370	[-0.825; 4.545]	.175	0.833
gv on Vv	1.768	1.188	[-0.560; 4.096]	.137	0.700
Latent (Residual) Variances					
gv	0.075	0.100	[-0.121; 0.270]	.455	1
sv	0.143	0.214	[-0.276; 0.562]	.503	1
Fv	0.059	0.050	[-0.038; 0.156]	.235	0.441
Nv	0.114	0.071	[-0.026; 0.254]	.110	0.307
Vv	0.243	0.082	[0.081; 0.404]	.003	0.510
Residual Indicator Variances					
v.FF1	0.867	0.142	[0.589; 1.144]	<.001	0.867
v.FF2	0.804	0.085	[0.637; 0.970]	<.001	0.804
v.FF3	0.469	0.170	[0.136; 0.802]	.006	0.469
v.FN1	0.628	0.090	[0.451; 0.804]	<.001	0.628
v.FN2	0.601	0.094	[0.418; 0.784]	<.001	0.601
v.FN3	0.760	0.074	[0.615; 0.906]	<.001	0.760

v.FV1	0.524	0.083	[0.361; 0.687]	<.001	0.524
v.FV2	0.480	0.086	[0.312; 0.648]	<.001	0.480
v.FV3	0.577	0.082	[0.416; 0.738]	<.001	0.577
v.SF1	0.773	0.158	[0.463; 1.083]	<.001	0.773
v.SF2	0.617	0.096	[0.428; 0.806]	<.001	0.617
v.SF3	0.585	0.090	[0.408; 0.762]	<.001	0.585
v.SN1	0.491	0.098	[0.298; 0.684]	<.001	0.491
v.SN2	0.439	0.071	[0.300; 0.578]	<.001	0.439
v.SN3	0.411	0.073	[0.268; 0.553]	<.001	0.411
v.SV1	0.594	0.079	[0.440; 0.748]	<.001	0.594
v.SV2	0.698	0.082	[0.538; 0.858]	<.001	0.698
v.SV3	0.566	0.094	[0.381; 0.750]	<.001	0.566

Note. Missing p values indicate fixed parameters. The standardized solution is completely standardized.

Table C7
Combined Drift-Intelligence Model, freely estimated

Parameter	Estimate	SE	95% CI	<i>p</i>	Std. Est.
Loadings					
Fv on v.FF1	1	0			0.392
on v.FF2	1.180				0.463
on v.FF3	1.630				0.639
on v.SF1	0.758				0.297
on v.SF2	1.215				0.477
on v.SF3	1.554				0.610
Nv on v.FN1	1	0			0.526
on v.FN2	1.011	0.187	[0.645; 1.377]	<.001	0.532
on v.FN3	0.756	0.181	[0.401; 1.112]	<.001	0.398
on v.SN1	0.860	0.202	[0.464; 1.257]	<.001	0.453
on v.SN2	1.472	0.261	[0.960; 1.985]	<.001	0.775
on v.SN3	1.572	0.252	[1.078; 2.066]	<.001	0.827
Vv on v.FV1	1	0			0.679
on v.FV2	1.043	0.123	[0.803; 1.284]	<.001	0.709
on v.FV3	0.970	0.131	[0.714; 1.226]	<.001	0.659
on v.SV1	0.846	0.118	[0.615; 1.076]	<.001	0.575
on v.SV2	0.679	0.117	[0.450; 0.907]	<.001	0.461
on v.SV3	0.740	0.120	[0.505; 0.976]	<.001	0.503
sv on v.SF1	1	0			0.564
on v.SF2	0.537	0.230	[0.087; 0.988]	.019	0.303
on v.SF3	0.399	0.191	[0.025; 0.773]	.036	0.225
on v.SN1	0.641	0.219	[0.212; 1.070]	.003	0.362
on v.SN2	0.469	0.236	[0.008; 0.931]	.046	0.265
on v.SN3	0.151	0.188	[-0.218; 0.520]	.421	0.085
on v.SV1	0.392	0.168	[0.063; 0.721]	.020	0.221
on v.SV2	0.717	0.214	[0.297; 1.137]	.001	0.404
on v.SV3	0.747	0.182	[0.391; 1.104]	<.001	0.421
gv on Fv	1	0			0.885
gv on Nv	1.091				0.720
gv on Vv	1.191				0.608
gIQ on F_Mean	1	0			0.808
gIQ on N_Mean	0.858	0.033	[0.794; 0.923]	<.001	0.693
gIQ on V_Mean	0.833				0.673
FIQ on F_Mean	1	0			0.590
NIQ on N_Mean	1	0			0.721
VIQ on V_Mean	1	0			0.740
Covariances					
gv with gIQ	0.117				0.418
sv with gIQ	0.336	0.062	[0.214; 0.458]	<.001	0.739
Fv with FIQ	0.060	0.035	[-0.008; 0.128]	.082	0.561
Nv with NIQ	0.237	0.038	[0.162; 0.312]	<.001	0.899
Vv with VIQ	0.208	0.046	[0.119; 0.298]	<.001	0.522

Latent (Residual) Variances					
gv	0.121				1
gIQ	0.652	0.038	[0.578; 0.727]	<.001	1
sv	0.318	0.127	[0.068; 0.567]	.013	1
Fv	0.033	0.017	[0.000; 0.067]	.053	0.217
Nv	0.134	0.036	[0.000; 0.067]	<.001	0.482
Vv	0.291	0.080	[0.134; 0.448]	<.001	0.630
FIQ	0.348	0.038	[0.273; 0.422]	<.001	1
NIQ	0.519	0.059	[0.404; 0.634]	<.001	1
VIQ	0.548	0.052	[0.446; 0.649]	<.001	1
Residual Indicator Variances					
v.FF1	0.846				0.846
v.FF2	0.786	0.067	[0.655; 0.916]	<.001	0.786
v.FF3	0.591	0.097	[0.402; 0.780]	<.001	0.591
v.FN1	0.723	0.085	[0.557; 0.890]	<.001	0.723
v.FN2	0.717	0.075	[0.571; 0.863]	<.001	0.717
v.FN3	0.842	0.064	[0.716; 0.967]	<.001	0.842
v.FV1	0.538	0.080	[0.382; 0.695]	<.001	0.538
v.FV2	0.497	0.077	[0.346; 0.649]	<.001	0.497
v.FV3	0.566	0.079	[0.412; 0.720]	<.001	0.566
v.SF1	0.594	0.102	[0.393; 0.794]	<.001	0.594
v.SF2	0.681	0.076	[0.531; 0.831]	<.001	0.681
v.SF3	0.578	0.061	[0.458; 0.697]	<.001	0.578
v.SN1	0.664	0.078	[0.512; 0.817]	<.001	0.664
v.SN2	0.330	0.054	[0.225; 0.435]	<.001	0.330
v.SN3	0.309	0.051	[0.209; 0.409]	<.001	0.309
v.SV1	0.621	0.076	[0.471; 0.771]	<.001	0.621
v.SV2	0.624	0.080	[0.466; 0.782]	<.001	0.624
v.SV3	0.570	0.082	[0.409; 0.731]	<.001	0.570
F_Mean/N_Mean/V_Mean	0	0			

Note. Missing *p* values indicate fixed parameters. The standardized solution is completely standardized. Caveat: unreliable estimates with some missing standard errors.

Table C8

Non-Decision Time Model 4 (hierarchical model of domains & g factor & slow method factor)

Parameter	Estimate	SE	95% CI	<i>p</i>	Std. Est.
Loadings					
<i>Ft₀</i> on <i>t₀</i> (each figural task)	1	0			0.539
<i>Nt₀</i> on <i>t₀</i> (each numeric task)	1	0			0.582
<i>Vt₀</i> on <i>t₀</i> (each verbal task)	1	0			0.613
<i>st₀</i> on <i>t₀</i> (each slow task)	1	0			0.273
<i>gt₀</i> on <i>Ft₀</i>	1	0			1.020
<i>gt₀</i> on <i>Nt₀</i>	1	0			0.944
<i>gt₀</i> on <i>Vt₀</i>	1	0			0.897
Latent (Residual) Variances					
<i>gt₀</i>	0.302	0.021	[0.261; 0.344]	<.001	1
<i>st₀</i>	0.075	0.019	[0.038; 0.112]	<.001	1
<i>Ft₀</i>	-0.012	0.021	[-0.054; 0.031]	.592	-0.040
<i>Nt₀</i>	0.037	0.023	[-0.009; 0.083]	.117	0.108
<i>Vt₀</i>	0.074	0.026	[0.023; 0.124]	.004	0.196
Residual Indicator Variances					
<i>t₀</i> (each fast figural task)	0.709	0.029	[0.652; 0.767]	<.001	0.709
<i>t₀</i> (each fast numeric task)	0.661	0.029	[0.605; 0.717]	<.001	0.661
<i>t₀</i> (each fast verbal task)	0.624	0.028	[0.568; 0.680]	<.001	0.624
<i>t₀</i> (each slow figural task)	0.635	0.030	[0.575; 0.694]	<.001	0.635
<i>t₀</i> (each slow numeric task)	0.587	0.030	[0.527; 0.646]	<.001	0.587
<i>t₀</i> (each slow verbal task)	0.550	0.031	[0.488; 0.611]	<.001	0.550

Note. Missing *p* values indicate fixed parameters. The standardized solution is completely standardized.

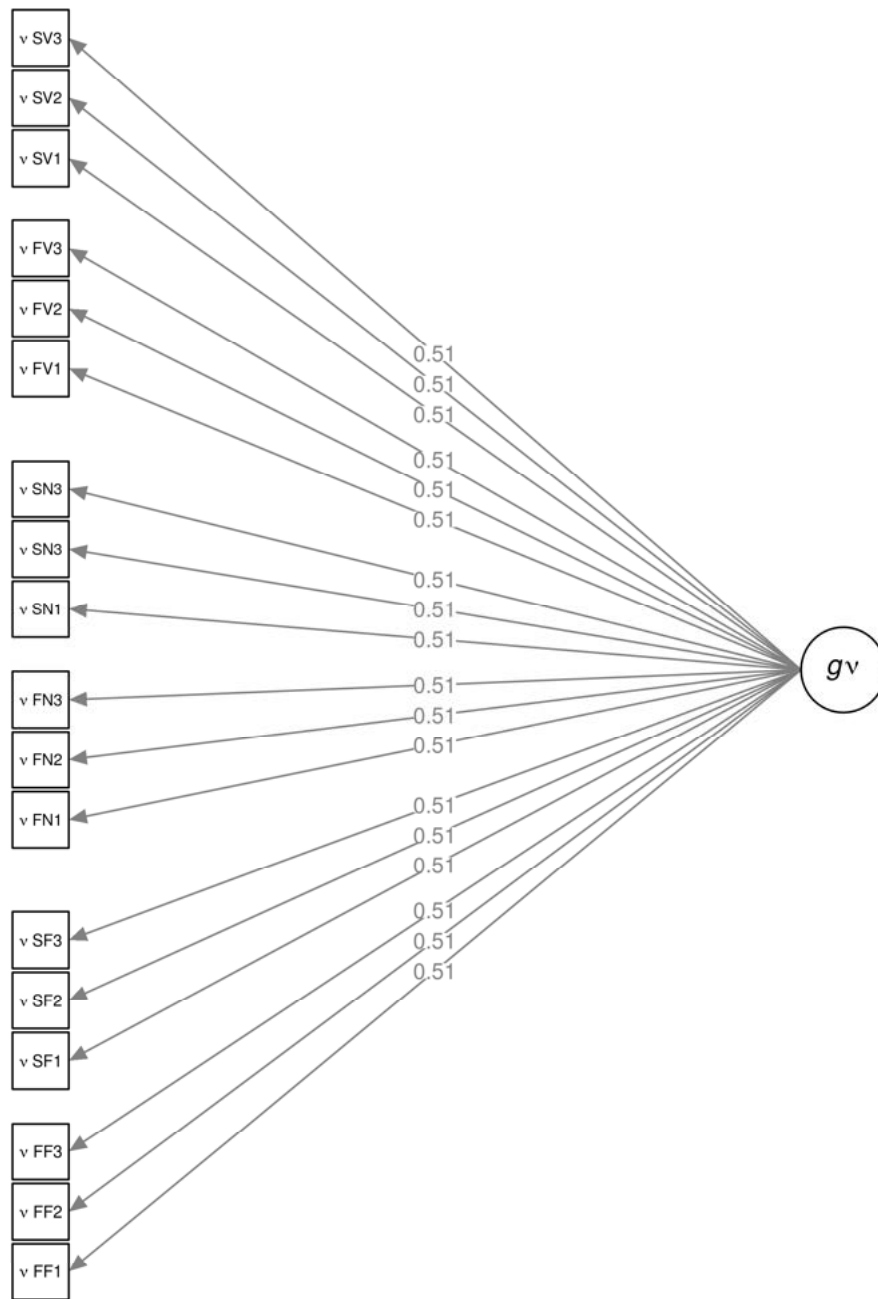

Figure C1. Drift Model 1. The first letter of the task indices denotes the type of task (F = fast, S = slow); the second letter indicates the domain (N = numeric, V = verbal, F = figural). See Table 1 for a brief description of all tasks. Standardized loadings reported. Residuals are omitted from the plot for simplicity. *gv* = general drift rate factor.

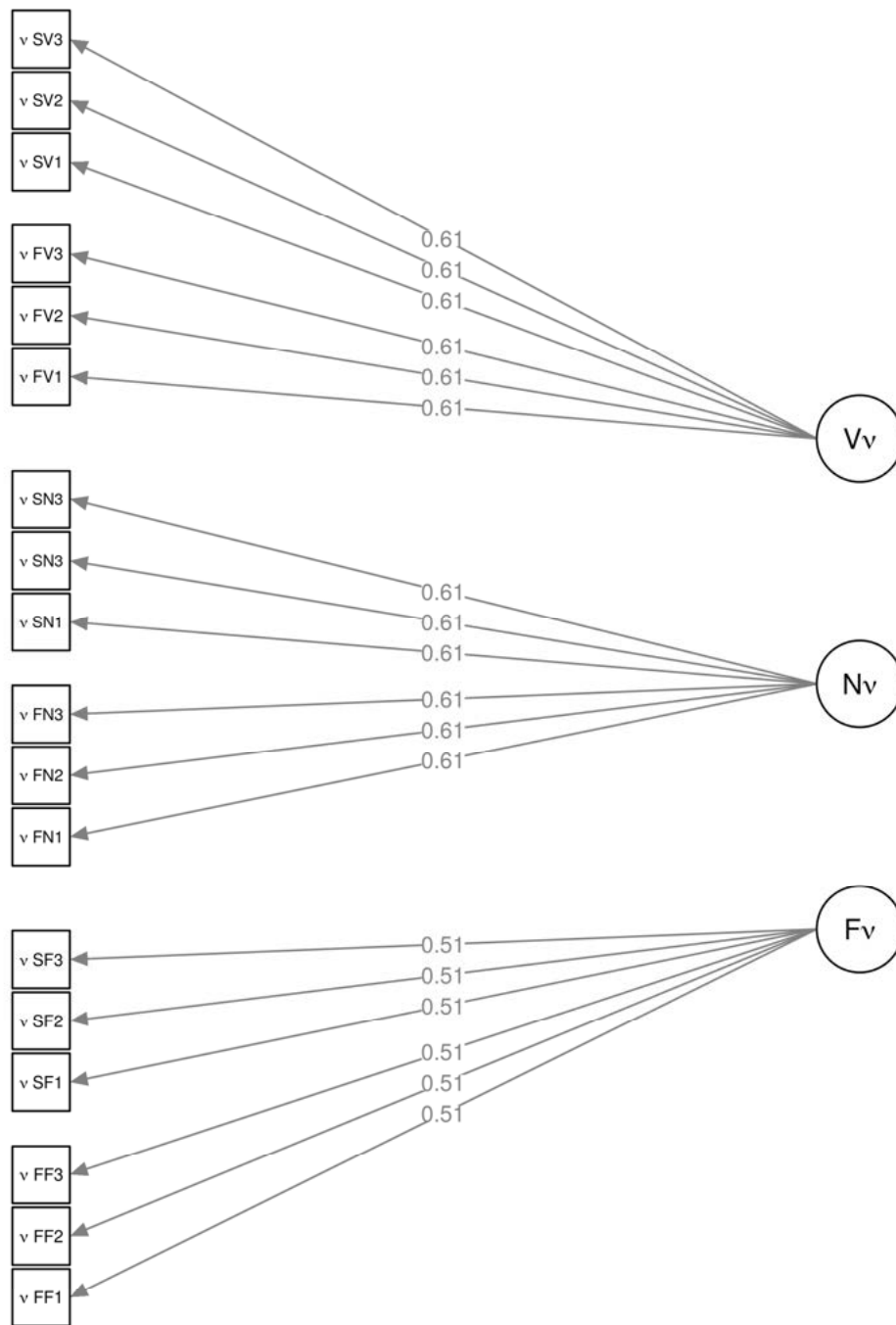

Figure C2. Drift Model 2. The first letter of the task indices denotes the type of task (F = fast, S = slow); the second letter indicates the domain (N = numeric, V = verbal, F = figural). See Table 1 for a brief description of all tasks. Standardized loadings reported. Residuals are omitted from the plot for simplicity. V_v = verbal drift rate factor. N_v = numeric drift rate factor. F_v = figural drift rate factor.

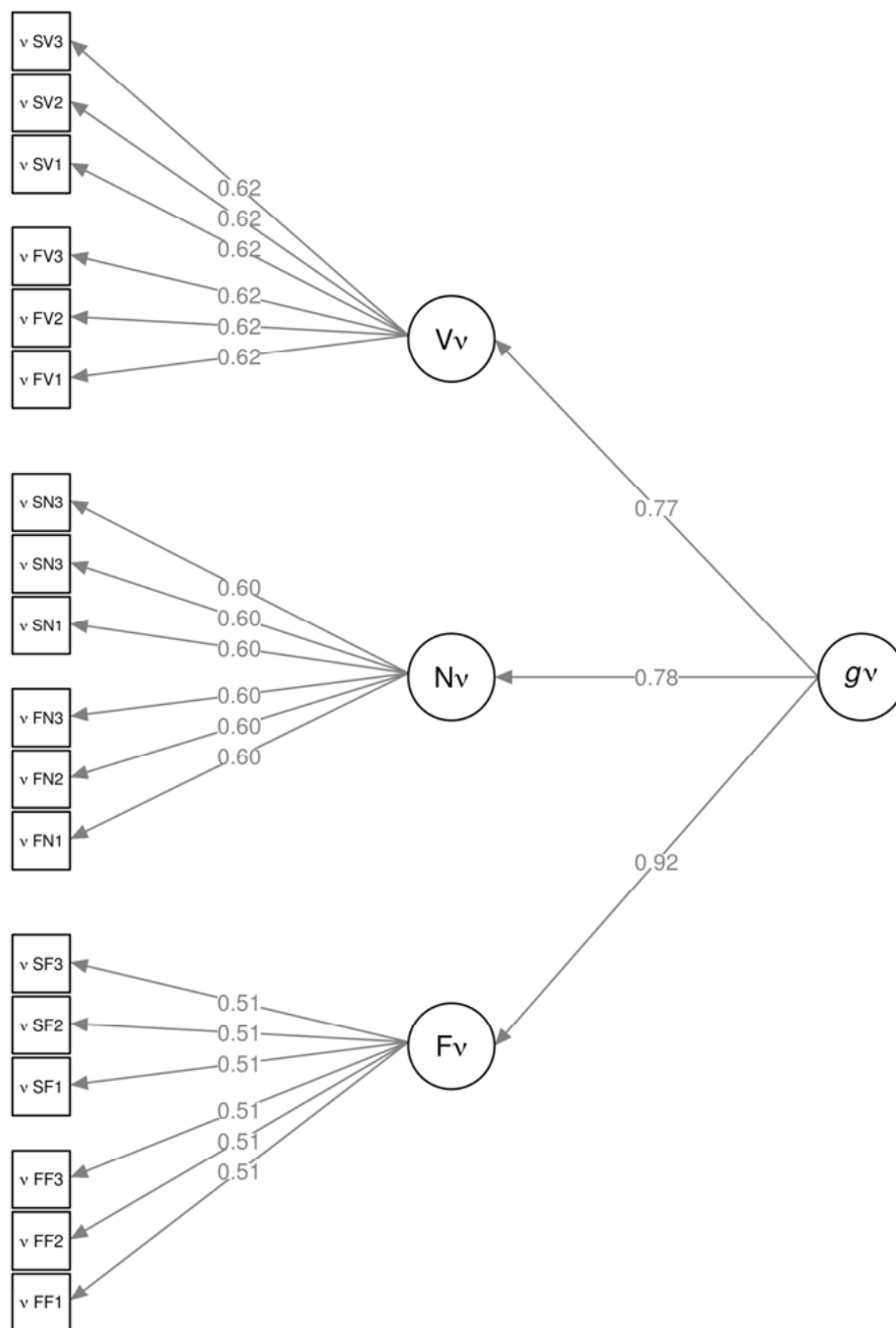

Figure C3. Drift Model 3. The first letter of the task indices denotes the type of task (F = fast, S = slow); the second letter indicates the domain (N = numeric, V = verbal, F = figural). See Table 1 for a brief description of all tasks. Standardized loadings reported. Residuals are omitted from the plot for simplicity. g_v = general drift rate factor. V_v = verbal drift rate factor. N_v = numeric drift rate factor. F_v = figural drift rate factor. As the loadings of the drift domain factors are standardized on the different freely estimated variances of the domain factors, their standardized values differ although the unstandardized loadings are all fixed to 1.

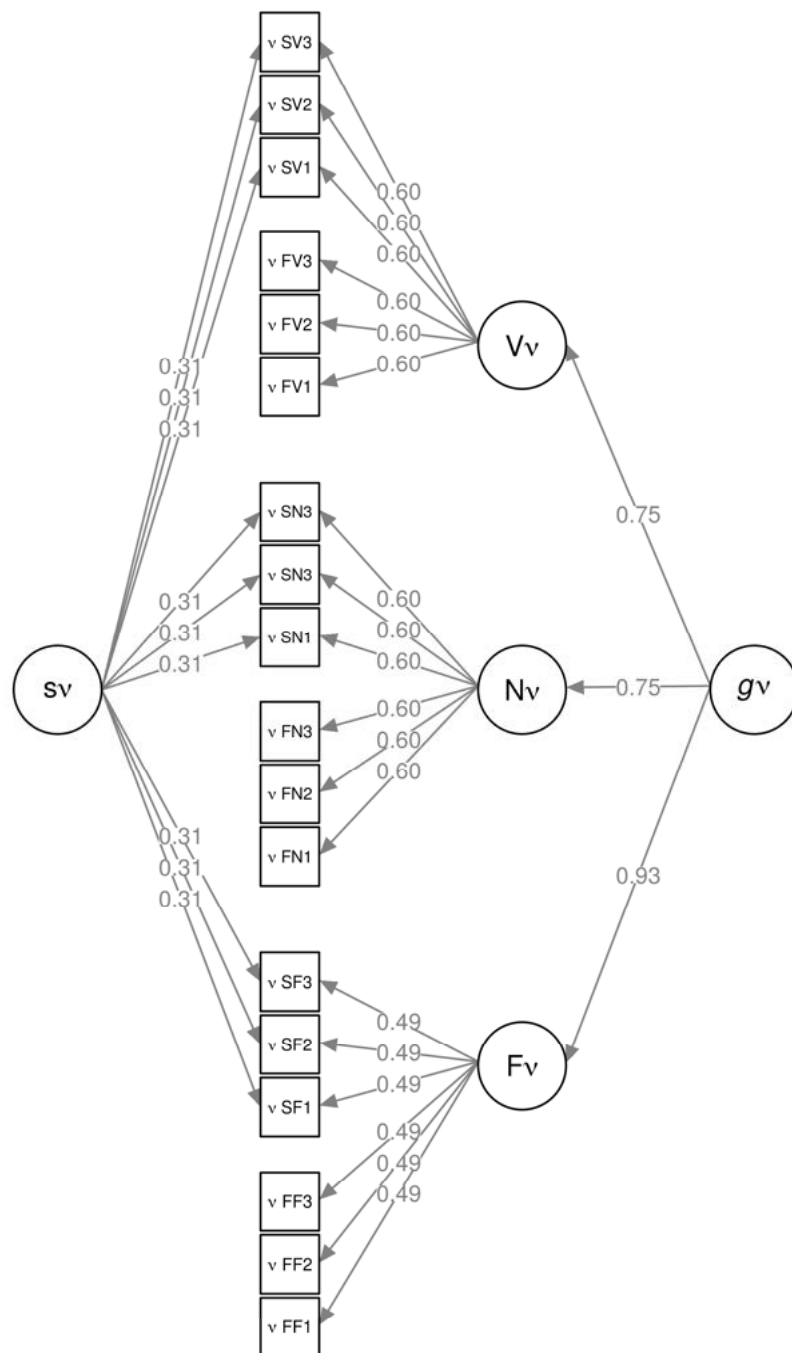

Figure C4. Drift Model 4. The first letter of the task indices denotes the type of task (F = fast, S = slow); the second letter indicates the domain (N = numeric, V = verbal, F = figural). See Table 1 for a brief description of all tasks. Standardized loadings reported. Residuals are omitted from the plot for simplicity. gv = general drift rate factor. Vv = verbal drift rate factor. Nv = numeric drift rate factor. Fv = figural drift rate factor. sv = method factor for drift rate in slow tasks.

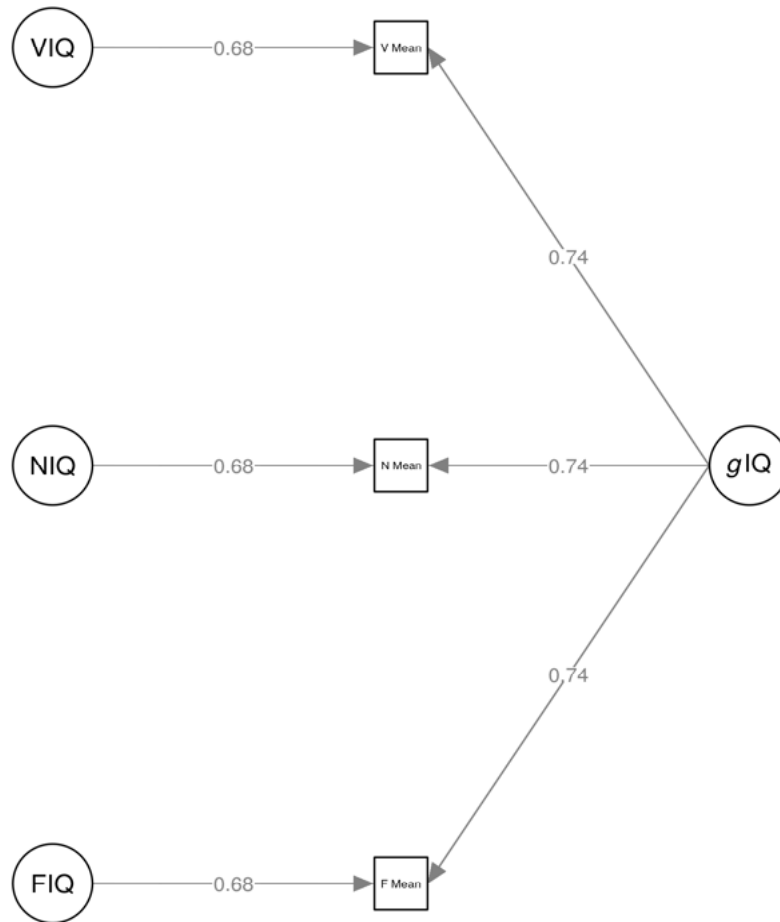

Figure C5. Intelligence Model. Scale means are used as indicators for verbal (VIQ), numeric (NIQ) and figural (FIQ) intelligence. gIQ = general intelligence. Completely standardized loadings are reported. Indicator residuals are fixed to zero, domain factors serve as quasi-residuals, see Methods.

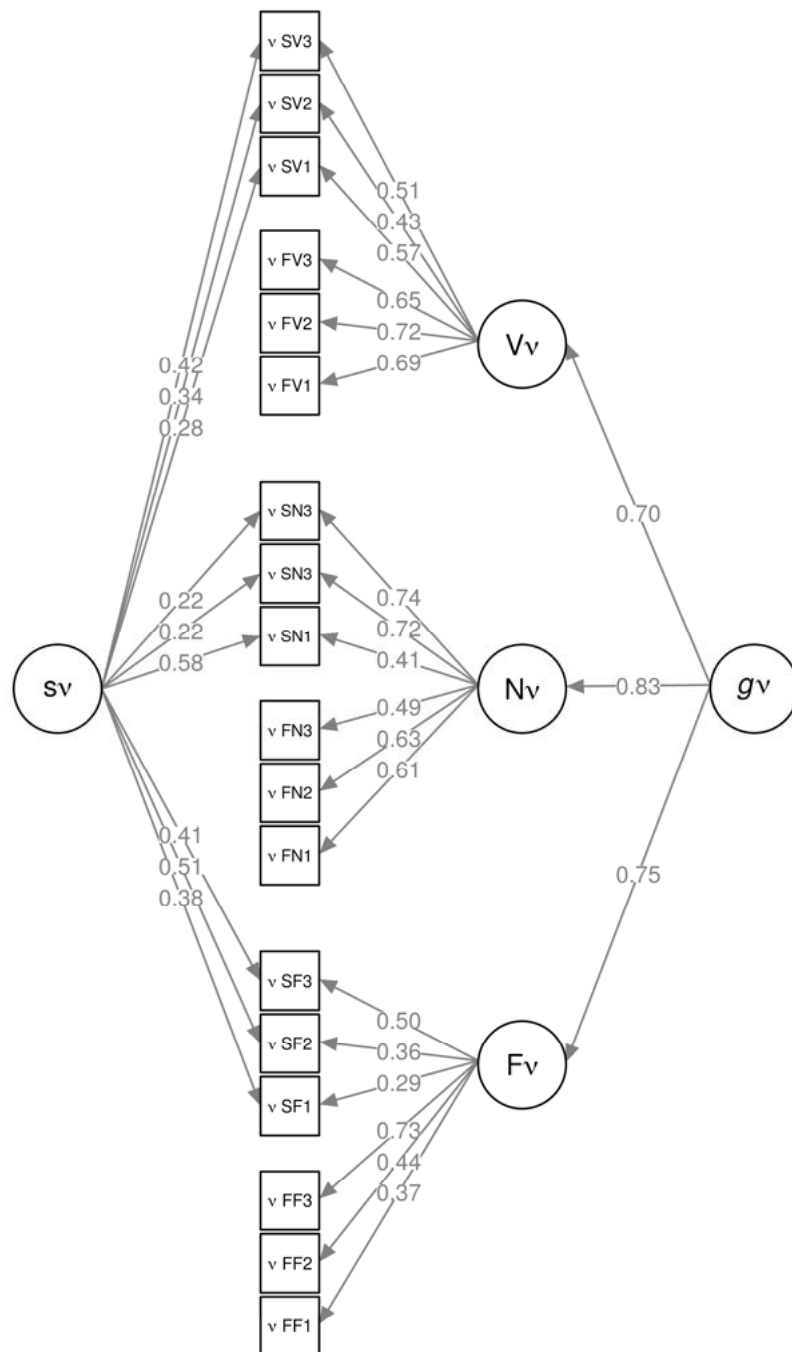

Figure C6. Drift Model 4 (freely estimated). The first letter of the task indices denotes the type of task (F = fast, S = slow); the second letter indicates the domain (N = numeric, V = verbal, F = figural). See Table 1 for a brief description of all tasks. Standardized loadings reported. Residuals are omitted from the plot for simplicity. gv = general drift rate factor. Vv = verbal drift rate factor. Nv = numeric drift rate factor. Fv = figural drift rate factor. sv = method factor for drift rate in slow tasks.

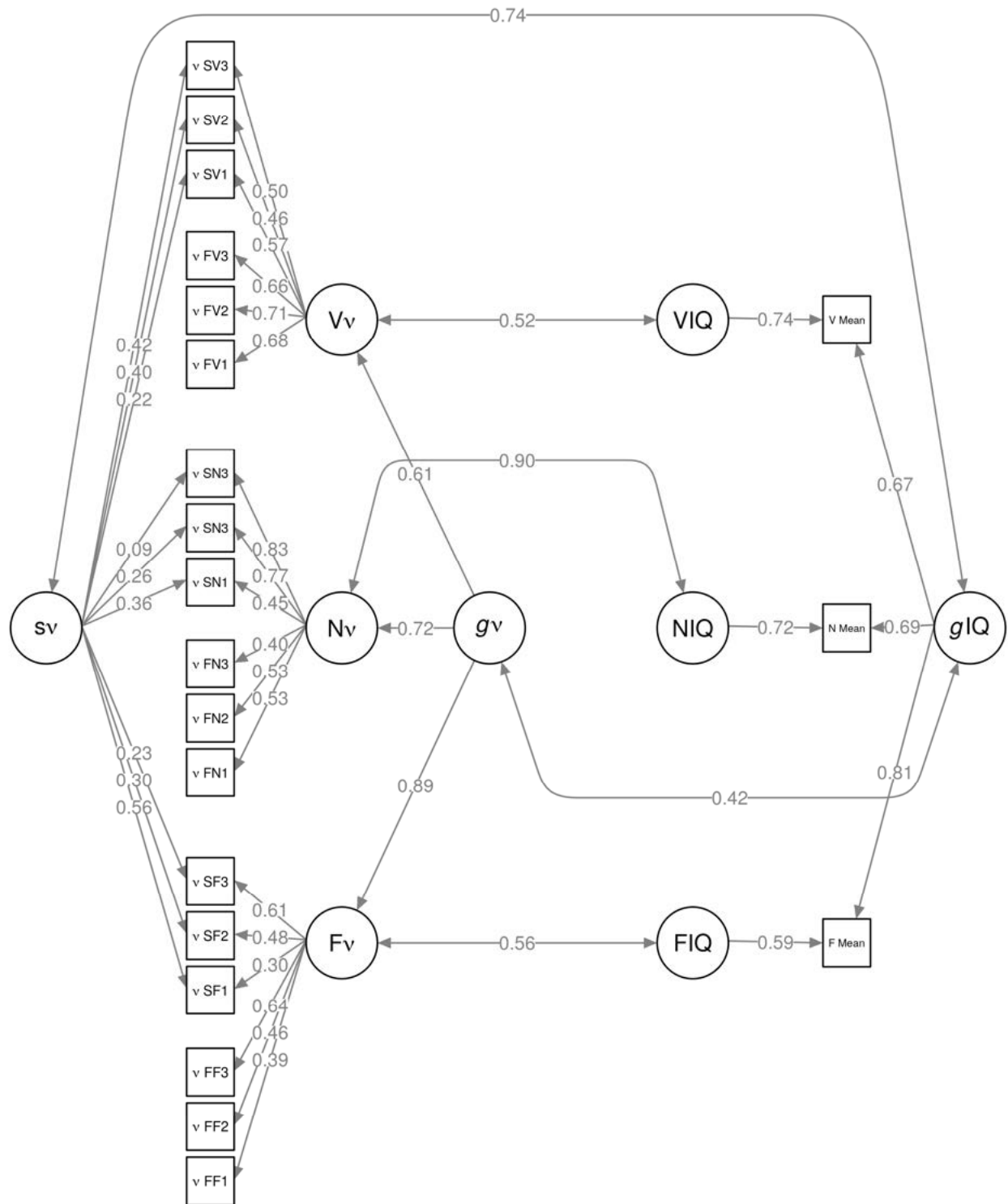

Figure C7. Combined Drift-Intelligence Model (freely estimated). The first letter of the task indices denotes the type of task (F = fast, S = slow); the second letter indicates the domain (N = numeric, V = verbal, F = figural). See Table 1 for a brief description of all tasks. Standardized loadings reported. Residuals are omitted from the plot for simplicity. The latent correlations between the drift domains and intelligence domains are between the drift domain residuals and the (quasi-residual) intelligence domain factors (see Methods). *g*v = general drift rate factor. *V*v = verbal drift rate factor. *N*v = numeric drift rate factor. *F*v = figural drift rate factor. *sv* = method factor for drift rate in slow tasks. Scale means are used as single indicators for verbal (VIQ), numeric (NIQ) and figural (FIQ) intelligence. *g*IQ = general intelligence.

Context of the Research

This research project is a cooperation of researchers from the departments of Quantitative Research Methods (VL, MVK, and AV) and Personality Research (GTF, ALS, and DH) of the Psychological Institute of Ruprecht-Karls-Universität Heidelberg. In this project, we could nicely combine the main expertise of the two labs, that is, diffusion modeling and intelligence research. In the preceding years, VL and AV have been contacted repeatedly by researchers who asked whether they could use the diffusion model also for more complex RT tasks. VL and AV conducted studies that provide first support for an extension to more complex tasks. Thereby arose the idea for a larger project, which includes numerous both fast and more complex RT tasks. GTF, ALS, and DH were always wondering whether there are domain-specific speeds of information processing but—because they usually additionally collect EEG data—they so far had refrained from running a study with such a large number of different RT tasks ($N = 18$). MVK is a PhD student who joined the team at the beginning of the recruitment for the study and has taken over an important role in the running of the study and the data analyses. He is currently examining the data further, focusing on age effects. One future research project will be the examination of relationships between drift rate in more complex tasks and external measures of performance (e.g., job performance).