



Digital coherent receiver for phase modulated radio-over-fibre optical links

Zibar, Darko; Yu, Xianbin; Peucheret, Christophe; Jeppesen, Palle; Tafur Monroy, Idelfonso

Published in:

I E E E Photonics Technology Letters

Link to article, DOI:

[10.1109/lpt.2008.2009359](https://doi.org/10.1109/lpt.2008.2009359)

Publication date:

2009

Document Version

Publisher's PDF, also known as Version of record

[Link back to DTU Orbit](#)

Citation (APA):

Zibar, D., Yu, X., Peucheret, C., Jeppesen, P., & Tafur Monroy, I. (2009). Digital coherent receiver for phase modulated radio-over-fibre optical links. *I E E E Photonics Technology Letters*, 21(1-4), 155-157. <https://doi.org/10.1109/lpt.2008.2009359>

General rights

Copyright and moral rights for the publications made accessible in the public portal are retained by the authors and/or other copyright owners and it is a condition of accessing publications that users recognise and abide by the legal requirements associated with these rights.

- Users may download and print one copy of any publication from the public portal for the purpose of private study or research.
- You may not further distribute the material or use it for any profit-making activity or commercial gain
- You may freely distribute the URL identifying the publication in the public portal

If you believe that this document breaches copyright please contact us providing details, and we will remove access to the work immediately and investigate your claim.

Digital Coherent Receiver for Phase-Modulated Radio-Over-Fiber Optical Links

Darko Zibar, Xianbin Yu, Christophe Peucheret, Palle Jeppesen, and Idelfonso T. Monroy

Abstract—A novel digital signal processing-based coherent receiver for phase-modulated radio-over-fiber (RoF) optical links is presented and demonstrated experimentally. Error-free demodulation of 50-Mbaud binary phase-shift keying (BPSK) and quadrature phase-shift keying data signal modulated on a 5-GHz radio-frequency (RF) carrier is experimentally demonstrated using the proposed digital coherent receiver. Additionally, a wavelength-division-multiplexing (WDM) phase-modulated RoF optical link is experimentally demonstrated. A 3×50 Mb/s WDM transmission of a BPSK modulated 5-GHz RF carrier is achieved over 25 km for the WDM channel spacing of 12.5 and 25 GHz, respectively.

Index Terms—Carrier recovery, coherent communication, digital receivers, digital signal processing (DSP), microwave photonics, phase-locked loop (PLL), phase-modulation.

I. INTRODUCTION

TRANSPORT and distribution of radio and wireless signals over fiber [radio-over-fiber (RoF)] is an important technology in order to realize converged fiber-optic and wireless networks [1]. Especially, RoF optical links employing optical phase modulation at the antenna base station have recently attracted much attention [2]–[4]. An immediate advantage of optical phase modulation over intensity modulation is that the process of imposing a high radio-frequency (RF) wireless signal on the optical carrier is inherently linear when conventional phase modulators are used. Additionally, phase-modulated RoF optical links do not require bias voltage for the optical phase modulator at the remote antenna base station. The challenge to implement a phase-modulated optical link lies in the receiver structure since optical phase-modulated links require a coherent receiver [2], [3]. With recent advances in integrated electronic circuits and digital signal processing (DSP), coherent receivers using DSP are becoming very attractive [3]. Recent efforts on digital coherent receivers for RoF optical links have mostly focused on analog communication with focus on linear demodulation [3]. We have recently proposed and experimentally demonstrated by proof-of-principle a novel DSP-based coherent receiver for phase-modulated RoF optical links employing a simple amplitude shift keying

modulation format for RF carriers [4]. However, as we move towards more complex RF modulation schemes, carrier recovery and RF phase estimation becomes more challenging. In this letter, we propose a DSP-based coherent receiver for digital RoF optical links. The proposed coherent receiver uses carrier-recovery digital phase-locked loop (PLL) to compensate for the frequency and phase difference between the transmitter and local oscillator (LO) laser, linear signal demodulation, and maximum likelihood carrier phase estimation (MLCPE) for RF carrier and phase estimation. Using the proposed digital coherent receiver, we report on the successful experimental demodulation of binary phase-shift keying (BPSK) and quadrature phase-shift keying (QPSK) phase-modulated RoF optical link at 5-GHz RF carrier. Additionally, we report on the successful experimental demonstration of a 3×50 Mb/s BPSK wavelength-division-multiplexing (WDM) phase-modulated RoF optical link over 25 km, using digital coherent detection. We demonstrate signal demodulation and subsequent data recovery for WDM channel spacing of 25 and 12.5 GHz.

II. SYSTEM SETUP AND DIGITAL COHERENT RECEIVER

The general outline of the experimental setup for the (WDM) phase-modulated RoF optical link and the proposed digital coherent receiver is shown in Fig. 1. The transmitter consists of three tunable DFB lasers with ~ 3 MHz linewidth and wavelengths in the range between 1550.20 and 1550.60 nm. The output of the transmitter is amplified by a high-power erbium-doped fiber amplifier. A vector signal generator is used to generate an RF carrier (5 GHz) which is modulated by a 50-Msymbol/s BPSK or QPSK data signal. The modulated RF data signal denoted $V_{in}(t)$ is then used to drive a conventional lithium-niobate optical phase modulator. After transmission through SMF, the phase-modulated optical data signal is then split in two polarizations using a polarization-beam splitter (PBS). At the receiver, a 90° optical hybrid is used to mix the received data signal with the tunable external cavity LO laser (~ 100 -kHz linewidth). According to Fig. 1, we have a polarization controller before the PBS at the receiver so that the polarization of the incoming signal is manually aligned to maximize the power input to the optical hybrid. Indeed, in practice, a polarization diversity scheme, or polarization tracking, could be implemented. The in-phase (I_i) and quadrature (I_q) optical signal components are detected with two pairs of balanced photodiodes (bandwidth 7.5 GHz). The wavelength of the LO laser is tunable in order to demultiplex different WDM channels. The detected photocurrents are digitalized at a sample rate of 40 Gs/s using a high-bandwidth real-time oscilloscope (Agilent Infinium DSO80000B with 13-GHz analog bandwidth). The sampled photocurrent is later used for offline signal demodulation and data recovery which is described in

Manuscript received August 13, 2008; revised October 13, 2008. First published November 21, 2008; current version published January 16, 2009. This work was supported by Villum-Kann-Rasmussen postdoctoral research Grant VKR-07-008.

The authors are with DTU Fotonik, Department of Photonics Engineering, Technical University of Denmark, Kgs. Lyngby DK-2800, Denmark (e-mail: dz@com.dtu.dk; xyu@com.dtu.dk; cp@com.dtu.dk; pj@com.dtu.dk; itm@com.dtu.dk).

Color versions of one or more of the figures in this letter are available online at <http://ieeexplore.ieee.org>.

Digital Object Identifier 10.1109/LPT.2008.2009359

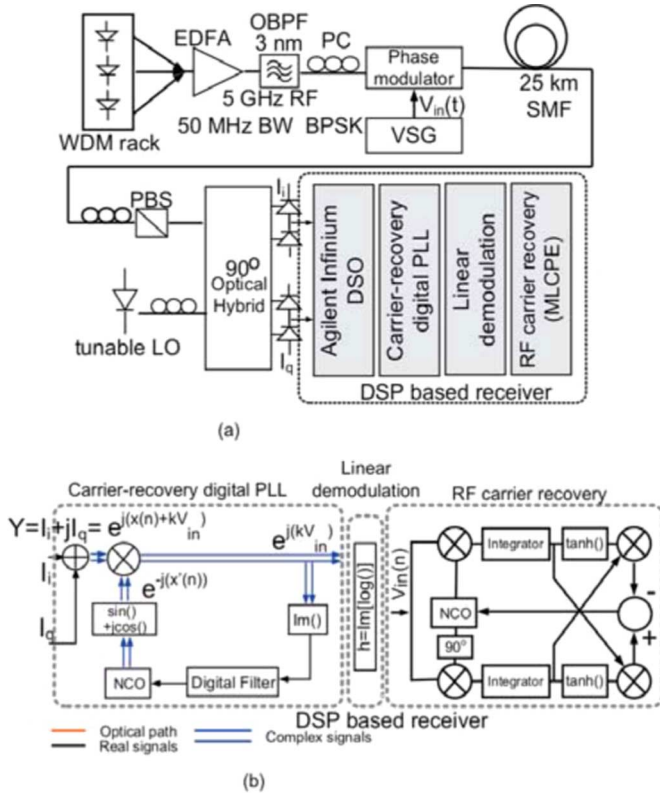

Fig. 1. (a) General outline for the experimental setup for demonstration of (WDM) phase-modulated RoF optical link using the digital coherent detection. (b) Outline of the proposed digital coherent receiver.

the following. The digitalized photocurrents form a complex quantity $Y[n] = I_i[n] + jI_q[n] \equiv e^{j(x(n)+kV_{in})}$, where n is an integer and k is a constant. The digital signal $Y[n]$ contains all the necessary information to compensate for the frequency and phase difference between the transmitter and LO laser ($x(n)$), recover the RF carrier frequency and phase, and finally recover the data. Following Fig. 1, we see that first the frequency offset between the transmitter laser and LO laser, contained in the complex quantity $Y[n]$, is removed using carrier-recovery digital PLL, thereafter the signal is linearly demodulated such that the output of the linear demodulator block corresponds to the RF signal at the transmitter, i.e., V_{in} , and finally the linearly demodulated signal is sent to the RF carrier recovery module to remove the RF carrier and phase and thereby perform signal demodulation. The carrier-recovery digital PLL consists of a phase rotator, phase-detector, digital low-pass filter, number controlled oscillator (NCO), and sine/cosine processor. The sine/cosine processor accepts the real NCO phase samples as input and delivers sine and cosine samples of those phases to produce a complex locally generated signal, i.e., $e^{-jx'(n)}$, where $x'(n)$ is an estimate of the frequency and phase difference between the transmitter and LO laser (see Fig. 1). The phase rotator performs a complex multiplication between the data signal $Y[n]$ and the locally generated signal, $e^{-jx'(n)}$, to produce a complex control signal for the carrier recovery loop. A phase detector algorithm $\Im\{e^{j(x(n)-x'(n)+kV_{in})}\}$, whose output is proportional to $\sin(x(n) - x'(n))$, provides an indication of the phase error. The digital signal from the phase detector is then passed through a digital (first-order)

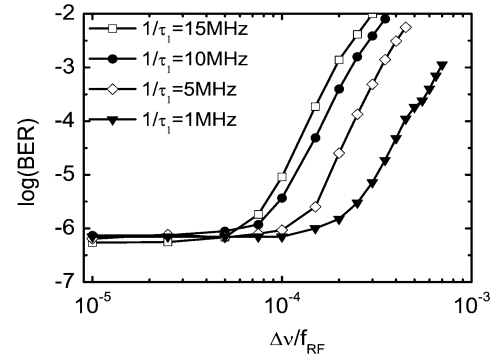

Fig. 2. Simulation results for BER as a function of the laser linewidth-to-RF carrier frequency ratio, $\Delta\nu/f_{RF}$, for the selected values of the digital proportional integrator filter bandwidth.

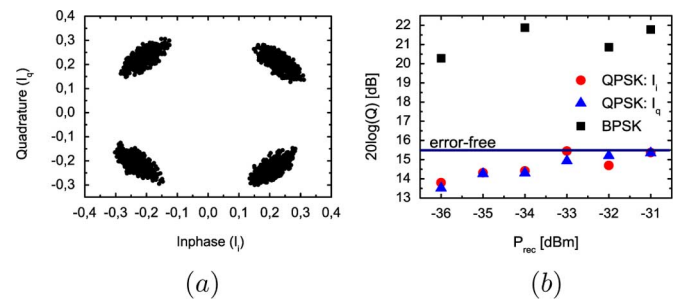

Fig. 3. (a) Constellation diagram of the demodulated QPSK data signal (5-GHz RF carrier) obtained from the experimental data. (b) Q -factor values, obtained from the experimental data, of the demodulated 50-Msymbol BPSK and QPSK data signal (5-GHz RF).

filter and the output from the digital filter controls the NCO. When the carrier-recovery digital PLL is locked, the frequency and phase difference between the transmitter and LO laser is removed from the complex signal $Y[n] \propto e^{jkV_{in}}$. Next, we linearly demodulate the phase-encoded RF data signal V_{in} through the relation $\Im\{\ln\{e^{jkV_{in}}\}\}$ [3]. The signal after linear demodulation is sent to MLCPE the RF carrier phase, where the data can be demodulated. Recognizing that $\tanh(w) = 1$ for $w \gg 1$ and -1 for $w \ll 1$, we see that we have the decision-directed RF carrier recovery. The maximum likelihood RF phase estimation is derived by demodulating the signal by sine and cosine derived from the common NCO running at F_{RF}/F_s (F_{RF} : RF carrier frequency; F_s : sampling frequency), doing separate integration operation slicing the data [6]. Next, in Fig. 2, we briefly investigate the tolerance of the digital coherent receiver on the laser linewidth using numerical simulations. The bit-error rate (BER) is computed as a function of the laser linewidth-to-RF carrier frequency ratio, $\Delta\nu/f_{RF}$, for selected values of the low-pass digital filter bandwidth in the carrier-recovery DPLL. It is observed that wider laser linewidth can be tolerated by decreasing loop filter bandwidth. We should keep in mind that by decreasing the loop filter bandwidth, the overall loop gain will be decreased as well, which in the end will limit the tracking range of the carrier-recovery DPLL.

III. EXPERIMENTAL RESULTS

Fig. 3(a) illustrates a constellation diagram of the 50-Msymbol/s QPSK signal recovered from the optical phase-modulated link (5-GHz RF carrier) after transmission

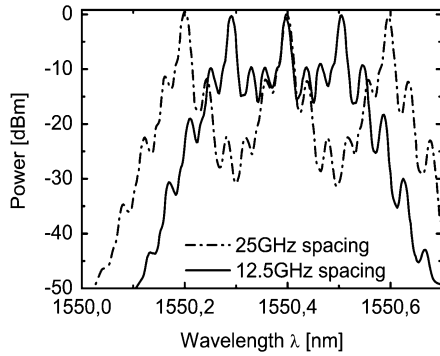

Fig. 4. Measured optical spectra of WDM phase-modulated RoF optical signal.

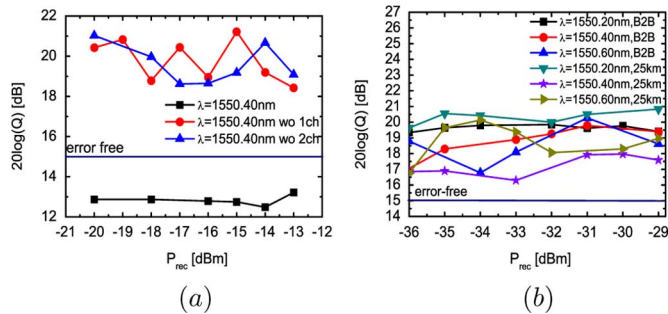

Fig. 5. (a) Q -factor of demodulated WDM channel ($\lambda_2 = 1550.40$) nm for a WDM channel spacing of 12.5 GHz. (b) Q -factor of demodulated WDM channels (25-GHz spacing) for back-to-back and after 25 km.

through couple of meters of fiber. Fig. 3(a) demonstrates that the digital receiver can be successfully used for QPSK signal demodulation in the subcarrier phase-modulated optical link. In Fig. 3(b), the Q -factor of the demodulated 5-GHz RF carrier employing 50-Mb/s BPSK and 100-Mb/s QPSK data modulation is shown as a function of average received power for the back-to back measurement. For BPSK modulation, the high values of the Q -factor indicate that error-free (BER better than 10^{-9} , corresponding to Q larger than 15.6 dB) signal demodulation is achieved in the whole considered range of the received optical power levels. The values of the Q -factor of the in-phase and quadrature tributaries of the demodulated QPSK signal are below the Q -factor values for the BPSK modulated signal. Since the same average power was used for BPSK and QPSK, the power of each in-phase/quadrature tributary of the QPSK signal is lower compared to the power of the BPSK signal, resulting in a lower Q -factor for the QPSK signal tributaries. The degradation could also be attributed to the increased sensitivity of QPSK systems towards laser linewidth. Additionally, imperfections in the RF carrier phase estimation scheme for the QPSK signal may also contribute to the observed performance degradation. Fig. 4 shows the optical spectra of the WDM phase-modulated RoF optical signal when the WDM channel spacing is 12.5 and 25 GHz, respectively. As the WDM channel spacing is reduced to 12.5 GHz, significant overlap among channels is observed, making the signal recovery very challenging. To begin with, the WDM channel spacing is set to 12.5 GHz. In Fig. 5(a), the Q -factor of the demodulated WDM channel at $\lambda_2 = 1550.40$ nm is shown as

a function of average received optical power. Results are only provided for the center channel at λ_2 since it is the one that experiences most crosstalk from the two neighboring channels. Three different scenarios are considered: 1) two neighboring WDM channels at $\lambda_1 = 1550.20$ nm and $\lambda_3 = 1550.60$ nm are present; 2) the WDM channel at $\lambda_1 = 1550.20$ nm is removed; and 3) the WDM channels at $\lambda_1 = 1550.20$ nm and $\lambda_3 = 1550.60$ nm are both removed. The Q -factor of the demultiplexed and demodulated WDM channel at $\lambda_2 = 1550.40$ nm is about 13 dB, when the channels at $\lambda_1 = 1550.20$ nm and $\lambda_3 = 1550.60$ nm are simultaneously present. This is below 15.6 dB, which corresponds to error-free (BER better than 10^{-9}) signal demodulation and detection. From Fig. 5(a), it is observed that, as the neighboring channels are removed, the system performance in terms of Q -factor improves, as expected and the measured Q -factors are above 15.6 dB. Next, the WDM channel spacing is increased to 25 GHz. In Fig. 5(b), the Q -factor for the three demodulated WDM channels is shown for back-to-back measurement and after 25-km transmission in the case of 25-GHz channel spacing. The measured Q -factors are all above 15.6 dB, which corresponds to error-free signal demodulation and detection. We stress that, even though no dispersion compensation algorithm has been used, error-free signal demodulation is still obtainable after 25 km.

IV. CONCLUSION

A novel concept for DSP-based coherent receiver for phase-modulated RoF optical links has been proposed and experimentally demonstrated. We have experimentally shown that the digital coherent receiver can be used to successfully recover subcarrier modulated data employing BPSK/QPSK modulation formats. If more spectrally efficient modulation formats such as 16 QAM are used, RF carrier recovery becomes more challenging due to denser constellation diagrams and laser phase noise. Additionally, we have experimentally demonstrated a novel concept of WDM phase-modulated RoF link using digital coherent detection. The system could potentially be upgraded to operate at higher RF frequencies. The main limitations originate from the bandwidth of the photodiodes and sampler at the receiver. The receiver could also be used for subcarrier multiplexed systems, if a bandpass filter is applied for channel selection after linear demodulation.

REFERENCES

- [1] J. Capmany and D. Novak, "Microwave photonics combines two worlds," *Nature Photonics*, vol. 1, pp. 319–330, Jun. 2007.
- [2] H. F. Chou, A. Ramaswamy, D. Zibar, L. A. Johansson, J. E. Bowers, M. Rodwell, and L. A. Coldren, "High-linearity coherent receiver with feedback," *IEEE Photon. Technol. Lett.*, vol. 19, no. 12, pp. 940–942, Jun. 15, 2007.
- [3] T. R. Clark and M. L. Dennis, "Coherent optical phase-modulation link," *IEEE Photon. Technol. Lett.*, vol. 19, no. 16, pp. 1206–1208, Aug. 2007.
- [4] D. Zibar, I. T. Monroy, C. Peucheret, L. A. Johansson, J. E. Bowers, and P. Jeppesen, "DSP based coherent receiver for phase-modulated radio-over-fibre optical links," in *Proc. Optical Fibre Communication Conf. (OFC 2008)*, Anaheim, CA, 2008, Paper OThH3.
- [5] F. Gardner, *Phase Lock Techniques*, 3rd ed. Hoboken, NJ: Wiley, 2004.
- [6] J. Kuszweil, *An Introduction to Digital Communication*. Hoboken, NJ: Wiley, 2000.