

Digital Optical Signal Processing with Polarization-Bistable Semiconductor Lasers

JAI-MING LIU, MEMBER, IEEE, AND YING-CHIN CHEN, MEMBER, IEEE

Abstract—The operations of a complete set of optical AND, NAND, OR, and NOR gates and clocked optical *S-R*, *D*, *J-K*, and *T* flip-flops are demonstrated, based on direct polarization switching and polarization bistability, which we have recently observed in InGaAsP/InP semiconductor lasers. By operating the laser in the direct-polarization-switchable mode, the output of the laser can be directly switched between the TM_{00} and TE_{00} modes with high extinction ratios by changing the injection-current level, and optical logic gates are constructed with two optoelectronic switches or photodetectors. In the polarization-bistable mode, the laser exhibits controllable hysteresis loops in the polarization-resolved power versus current characteristics. When the laser is biased in the middle of the hysteresis loop, the light output can be switched between the two polarization states by injection of short electrical or optical pulses, and clocked optical flip-flops are constructed with a few optoelectronic switches and/or photodetectors. The 1 and 0 states of these devices are defined through polarization changes of the laser and direct complement functions are obtainable from the TE and TM output signals from the same laser. Switching of the polarization-bistable lasers with fast-rising current pulses has an instrument-limited mode-switching time on the order of 1 ns. With fast optoelectronic switches and/or fast photodetectors, the overall switching speed of the logic gates and flip-flops is limited by the polarization-bistable laser to <1 ns. We have demonstrated the operations of these devices using optical signals generated by semiconductor lasers. The proposed schemes of our devices are compatible with monolithic integration based on current fabrication technology and are applicable to other types of bistable semiconductor lasers.

I. INTRODUCTION

THE basic building blocks of a digital system are logic gates and memory elements. Theoretically, any digital system can be constructed entirely from NAND (or NOR) gates and flip-flops, in which the gates perform combinational logic operations and the flip-flops perform sequential logic operations and memory functions. In conventional electronic systems, flip-flops are constructed by combining many logic gates with complicated circuitry. The switching speed of these flip-flops is limited primarily by the gate propagation delays. In order to realize digital optical signal processing and digital optical computing, optical logic gates and optical flip-flops must be developed. Some optical-logic-gate schemes based on electrooptic devices [1], optoelectronic devices [2], or nonlinear optical devices [3] have been proposed previously. Campbell *et al.* [2] have demonstrated the operation of an optical AND gate with optical input signals at two different wavelengths and the output signal at still another wavelength. Lattes *et al.* [3] recently proposed an optical XOR gate based on the guided-wave Mach-Zehnder interferometer. However, the realization

of its operation is still awaiting the discovery of materials of very large nonlinear optical coefficient. Tsang *et al.* [4] have demonstrated optoelectronic logic operations with cleaved-coupled-cavity semiconductor lasers in which the inputs are electrical signals and the outputs are optical signals at different wavelengths for different logic functions. Recently, Okumura *et al.* [5] reported the operations of optical flip-flops, an *S-R* and a *J-K* flip-flop, by combining many logic elements in the same way the electronic flip-flops are usually constructed. The circuitry is very complicated and the speed is extremely low (hundreds of microseconds). They are basically a simulation of electronic flip-flops with optical input and output.

In this paper, we present, with very simple circuitry, the operations of a complete set of optical logic gates and optical flip-flops based on direct polarization switching [6] and polarization bistability [7] in semiconductor lasers which we have recently observed. By operating the laser in the direct-polarization-switchable mode, logic gates such as AND, NAND, OR, and NOR are demonstrated with two optoelectronic switches [8], [9] or photodetectors. When the laser is operated in the polarization-bistable mode, clocked optical flip-flops are constructed and demonstrated with a few optoelectronic switches or photodetectors. Unlike the conventional electronic or optical flip-flops [5], our optical flip-flops are not constructed by combining logic gates. In fact, the circuits of our optical flip-flops are not more complicated than those of the logic gates. This is a great advantage for monolithic integration and high speed applications. Because the 1 and 0 states in a polarization bistable laser are defined through polarization changes, the laser is always lasing throughout the operation and it changes states without a change of the carrier density. Therefore, the switching speed of each element is, in principle, limited only by the response time of the optoelectronic switches (and/or the photodetectors) and the mode switching time of the laser. Subnanosecond overall switching speed can easily be achieved [7]–[9]. Since the laser changes states by switching between TE (electric field parallel to the junction) and TM (electric field normal to the junction) modes, the switching behavior of one mode is always complementary to that of the other. In a logic gate, the output signals from the same laser in each of the two orthogonal polarizations represent two complement logic functions. In a flip-flop, they directly constitute the normal output, Q , and its complement, \bar{Q} , respectively. This special feature is certainly not available in conventional intensity-bistable semiconductor lasers [10]. The number of components in a flip-flop is reduced as no extra components for generating the complement output are necessary. Since the TE and TM comple-

Manuscript received November 5, 1984.

The authors are with GTE Laboratories, Inc., Waltham, MA 02254.

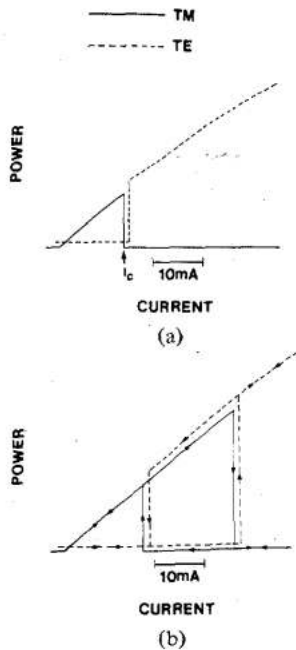

Fig. 1. Polarization-resolved CW power versus current characteristics of a polarization-bistable semiconductor laser. (a) The direct-polarization-switchable mode. (b) The polarization-bistable mode. The origins of the TE curves are shifted for clarity. Notice that the injection current is negative.

mentary output signals are emitted from the same laser with nearly the same spatial mode profile [7], they can be simultaneously coupled into and transmitted through the same optical waveguide, modulated and processed by mode-converter or electrooptics before they are separated. For example, by sending the beam through a half-wave plate, the functions carried by the TE and TM modes can be exchanged. In addition to these advantages of polarization-bistable lasers, the basic schemes of our circuitry also apply to the construction of logic gates and flip-flops with other types of bistable semiconductor lasers, such as the cleaved-coupled-cavity spectrum-bistable lasers [11] and the intensity-bistable lasers [10].

II. POLARIZATION-BISTABLE LASERS

The polarization-bistable lasers are V -grooved substrate buried heterostructure InGaAsP/InP lasers emitting at $1.3 \mu\text{m}$ wavelength. The same laser can be operated in the direct-polarization-switchable mode without hysteresis in the power versus current characteristics or in the polarization-bistable mode with controllable hysteresis in the power versus current characteristics, by controlling the operation temperature within a few degrees. These phenomena have been demonstrated in some InGaAsP/InP lasers operating near the characteristic polarization transition temperature, T_c , of each individual laser [12]. In this temperature regime, the laser operates in a pure TM_{00} mode at low injection currents and switches operation to a pure TE_{00} mode at high injection currents. At a temperature just below T_c , the polarization-resolved CW power-current characteristics of a laser exhibits an abrupt polarization transition at a characteristic injection-current level, I_c , as is shown schematically in Fig. 1(a). When a laser is operated in this direct-polarization-switchable mode, its output can be directly

switched between the TM_{00} and TE_{00} modes by changing the injection-current level [6]. With fast-rising current pulses, subnanosecond switching speed can be achieved and the switching extinction ratio is very high [6].

With further decreases in the temperature, hysteresis loops with high contrast ratios can be observed in the polarization-resolved power-current characteristics, as is shown schematically in Fig. 1(b). The width of the hysteresis loop can be varied by controlling the operation temperature within a few degrees. As an example [7], a selected laser with $T_c = 195.2 \text{ K}$ exhibits a hysteresis loop of 1 mA at 193.5 K ; the hysteresis loop increases continuously to 23 mA at 186.7 K , and disappears with a further decrease in temperature. When the laser is operated in this polarization-bistable mode and is biased in the middle of the hysteresis loop, the light output can be switched between the two polarization states by injection of short electrical or optical pulses [7]. If the laser initially operates in the TM_{00} mode, a negative current pulse can switch the laser output to the TE_{00} mode, while a subsequent positive current pulse switches it back to the TM_{00} mode. Notice that the injection current in Fig. 1(a) and (b) is negative. With very short single current pulses, instrument-limited switching time on the order of 1 ns has been observed [7].

III. LOGIC AND INVERTER

Since the laser is always lasing throughout the operation and changes states by changing the polarization of the output emission, we have two possible logic operations.

A. Intensity-Defined Logic

The binary states are defined as conventionally by the level of the light intensity, disregarding the polarization. For example, if positive logic is used, a high intensity output is 1 and a low or zero intensity output is 0. Since the laser is always lasing either in the TE or TM mode, the logic function carried by the TE output is always the complement of that carried by the TM output. They can be transmitted through the same optical waveguide. However, the two polarizations must be separated before the digital data or functions carried by each mode (say A in the TE mode, \bar{A} in the TM mode) can be read and processed. In this mode of logic operation, the INVERTER is built-in since the complement function is always accompanying the normal function in the emission of the same laser.

B. Polarization-Defined Logic

Alternatively, we can define one polarization as the 1 state, the other as the 0 state, disregarding the absolute intensity level. That is, TE is 1 and TM is 0, or vice versa. In this case, only one set of digital data or logic function is carried by the output of a laser. The TE and TM modes cannot be separated when the data are read or processed. A TE-TM mode converter, such as a half-wave plate, is an INVERTER.

In the following descriptions of optical logic gates and optical flip-flops, we use the positive intensity-defined logic.

IV. OPTICAL LOGIC GATES

For optical logic operations, optical bistability is not necessary. The laser is operated in the direct-polarization-switchable

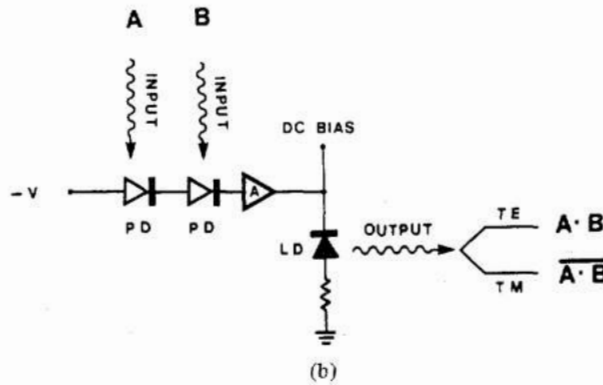
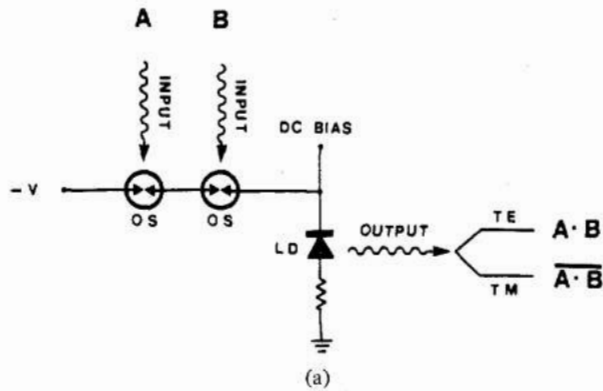

Fig. 2. Circuit diagrams of an optical AND gate for the TE light emission and optical NAND gate for the TM emission. (a) The input ports are optoelectronic switches (OS). (b) The input ports are reverse-biased photodetectors (PD).

mode with the CW power-current characteristics shown in Fig. 1(a). At a current level below I_c , the laser output is TM-polarized. Above I_c , the laser output changes polarization to TE. Notice that the polarity of the injection current is negative.

In principle, any logic function can be constructed entirely from NAND gates or from NOR gates. However, for the purpose of completeness, we present the circuit of each individual gate. Since the TE and TM outputs from a laser are complement functions in the intensiy-defined logic, an AND gate for the TE light emission is a NAND for the TM emission, and vice versa. Similarly, an OR gate for the TE emission is a NOR for the TM emission, and vice versa.

A. AND and NAND

Fig. 2 shows the TE-AND (TM-NAND) gate. In Fig. 2(a), the circuit consists of two high-speed optoelectronic switches [8], [9] (OS) in series. The laser diode (LD) is biased just below the polarization-switching current level, I_c . When either or both input signals are 0, the switches in series are not conducting and the laser output is TM-polarized. When both input signals, A and B , are 1, the switches are both conducting. The negative voltage, $-V$, and the impedances of the switches are adjusted so that when both switches are conducting, the injection-current level is higher than I_c and the laser output switches into the TE polarization. The TE output represents the logic function $A \cdot B$ and the TM output represents $\overline{A \cdot B}$.

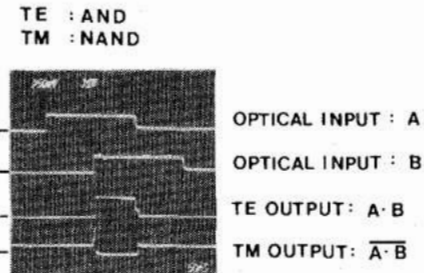

Fig. 3. Operation of the TE-AND (TM-NAND) optical logic gate shown in Fig. 2(b). All traces are optical signals.

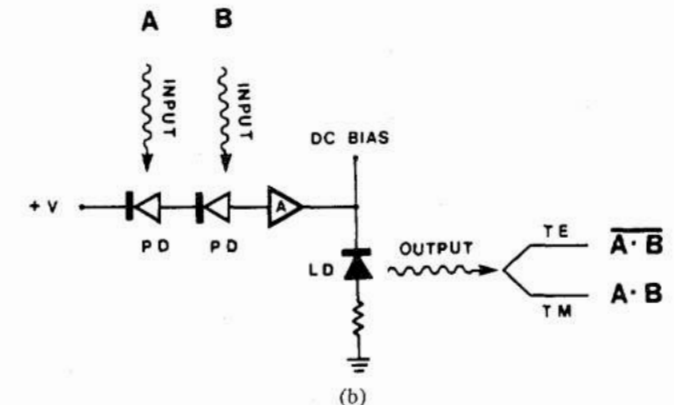
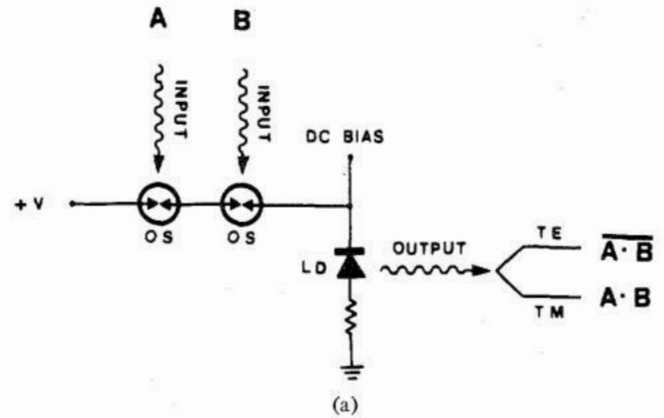

Fig. 4. Circuit diagrams of an optical NAND gate for the TE light emission and AND gate for the TM emission using (a) optoelectronic switches and (b) photodetectors.

The optoelectronic switches in Fig. 2(a) can be replaced with two photodetectors in series, connected under reverse bias. The alternative circuit consisting of photodetectors is shown in Fig. 2(b). Since photodetectors generally do not deliver much current, an amplifier may be necessary. With the optoelectronics switches, it is possible to switch the laser without an amplifier [7], [9]. The operation of the TE-AND (TM-NAND) gate is demonstrated in Fig. 3.

Fig. 4 shows the TE-NAND (TM-AND) gate. In these circuits, the optoelectronic switches and the photodetectors are biased with a positive voltage, $+V$, and the laser is biased negatively at a current level just above I_c . The operations of these circuits

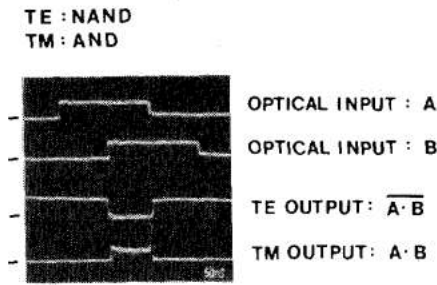

Fig. 5. Operation of the TE-NAND (TM-AND) optical logic gate in Fig. 4(b). All traces are optical signals.

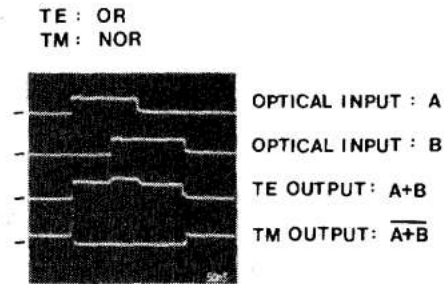
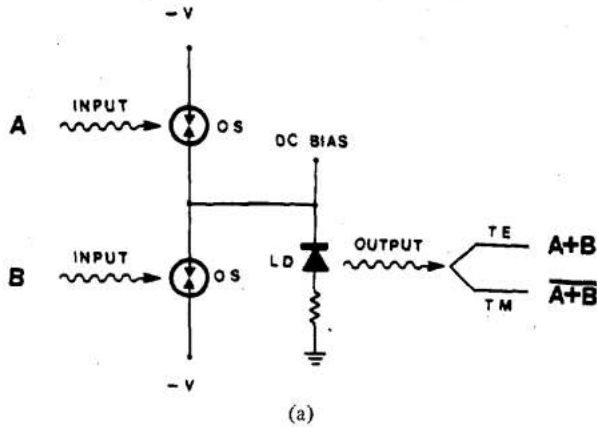
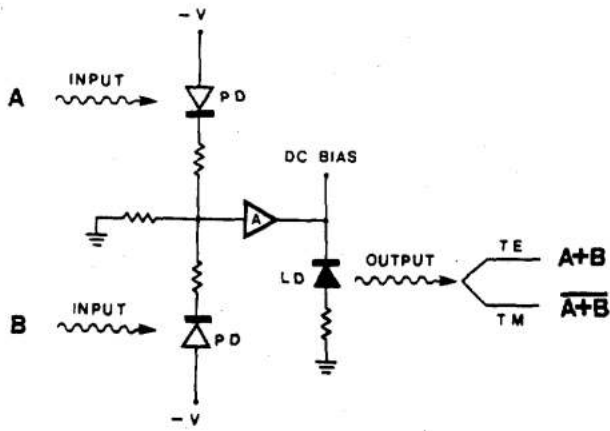

Fig. 7. Operation of the TE-OR (TM-NOR) optical logic gate shown in Fig. 6(b). All traces are optical signals.



(a)



(b)

Fig. 6. Circuit diagrams of a TE-OR and TM-NOR gate using (a) optoelectronic switches and (b) photodetectors.

are similar to those in Fig. 2, except that the TE output now represents $\overline{A \cdot B}$ and the TM output represents $A \cdot B$. Fig. 5 shows the operation of the TE-NAND (TM-AND) gate.

B. OR and NOR

Fig. 6 shows the TE-OR (TM-NOR) gate. In Fig. 6(a), two optoelectronic switches in parallel are each negatively biased with the same voltage $-V$, and the laser diode is biased at a dc level just below I_c . The circuit parameters are adjusted so that one conducting switch is enough to increase the injection current level above I_c to switch the laser output from TM to TE polarization. The TE and TM output signals, therefore, represent $A + B$ and $\overline{A + B}$, respectively. Fig. 6(b) shows an alter-

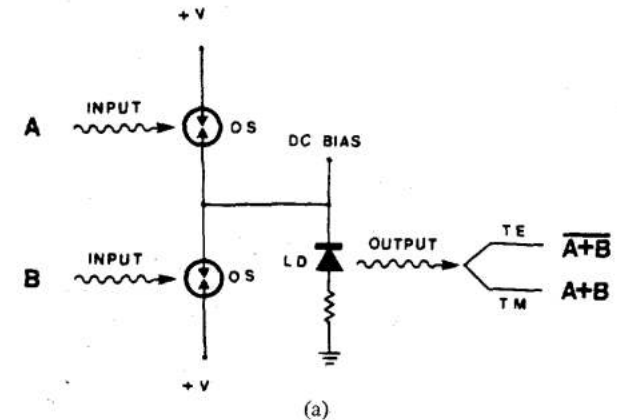

(a)

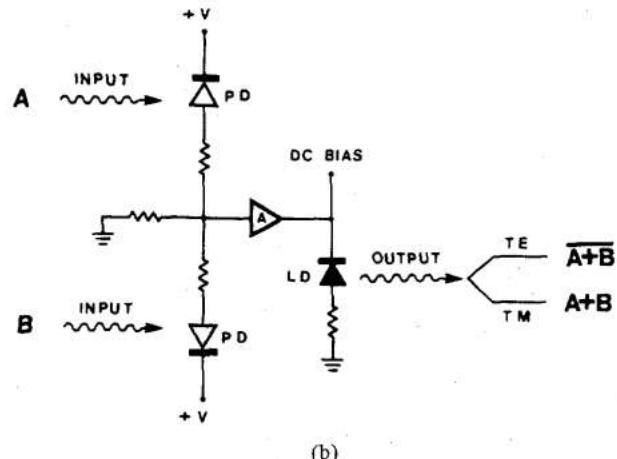

(b)

Fig. 8. Circuit diagrams of a TE-NOR and TM-OR gate. (a) Optoelectronic switches. (b) Photodetectors.

native circuit using photodetectors. Fig. 7 demonstrates the operation of the TE-OR (TM-NOR) gate.

The TE-NOR (TM-OR) gate is shown in Fig. 8. The operations of these circuits are similar to those of the circuits in Fig. 6. However, the optoelectronic switches and the photodetectors are now biased with a positive voltage and the laser is biased negatively at an injection current level just above I_c . The TE and TM output signals represent $\overline{A + B}$ and $A + B$, respectively. The operation of the TE-NOR (TM-OR) gate is shown in Fig. 9.

V. OPTICAL FLIP-FLOPS

Flip-flops are the basic memory elements in a digital system. A flip-flop has two stable states and stores one bit of informa-

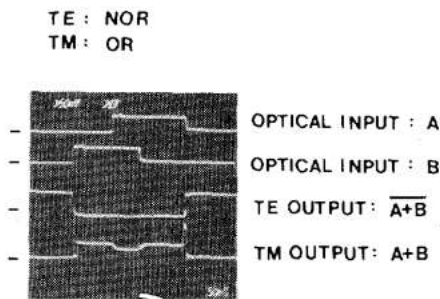

Fig. 9. Operation of the TE-NOR (TM-OR) optical logic gate shown in Fig. 8(b). All traces are optical signals.

tion in a binary system. Flip-flops are usually used in pulsed sequential logic systems, in which each of the flip-flops is a clocked device. The sequential systems are synchronous. They operate in synchronism with a train of system clock pulses, CP, at a fixed clock rate. One bit of information is defined by the time interval between two successive clock pulses. A clocked flip-flop changes state as a result of the occurrence of a clock pulse. Q_n refers to the state of a flip-flop before the occurrence of the CP, and Q_{n+1} refers to the state of the device after the occurrence of the CP. The basic operations of a flip-flop are: set ($Q_{n+1} = 1$), reset ($Q_{n+1} = 0$), and complement ($Q_{n+1} = \overline{Q}_n$).

There are basically four types of flip-flops: *S-R*, *D*, *J-K*, and *T*. In conventional electronic systems [13], the *S-R* flip-flop is the basic element and the other types of flip-flops are constructed with an *S-R* flip-flop and a few NAND gates. In the following, we demonstrate the operations of the four types of optical flip-flops with an independent circuit for each type. By operating the laser in the polarization-bistable mode as shown in Fig. 1(b), clocked optical flip-flops are constructed with very simple circuitry. Throughout the operation, the laser is biased in the middle of the hysteresis loop, and is switched between the two stable states of orthogonal polarization by short electrical pulses activated by a train of optical clock pulses. Without the use of extra NAND gates, the circuit for each type of flip-flop has similar simplicity and similar high speed.

A. *S-R* (Set-Reset) Flip-Flop

Fig. 10(a) shows the circuit of an optical *S-R* flip-flop consisting of three high-speed optoelectronic switches (OS) and a polarization-bistable laser diode (LD) which is biased in the middle of the hysteresis loop. Two switches are used as the input ports of the flip-flop to receive the digital optical input signals, *S* and *R*. A third switch, activated by a train of optical clock pulses, CP, is used to sample the output of the first two switches in synchronism with the clock pulses. The output pulses from this switch then trigger the laser diode to switch the polarization of its output at the repetition rate of the clock pulses. One bit of the output data is defined by the time interval between two successive clock pulses. As previously discussed, the TE and TM outputs constitute the normal output, Q , and its complement, \overline{Q} , respectively. In the absence of a clock pulse, changes in logic state at the data input cause no change in the output. At the moment a clock pulse arrives, if $S = 0$ and $R = 0$, no voltage is applied to the third switch and there is

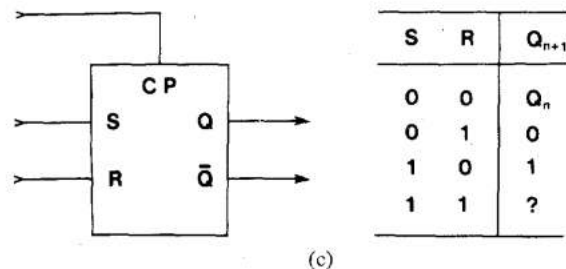
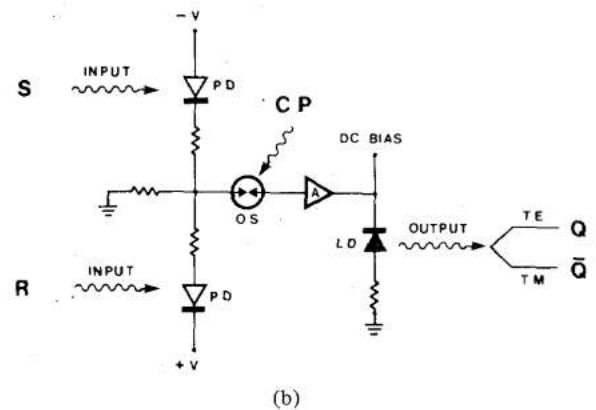
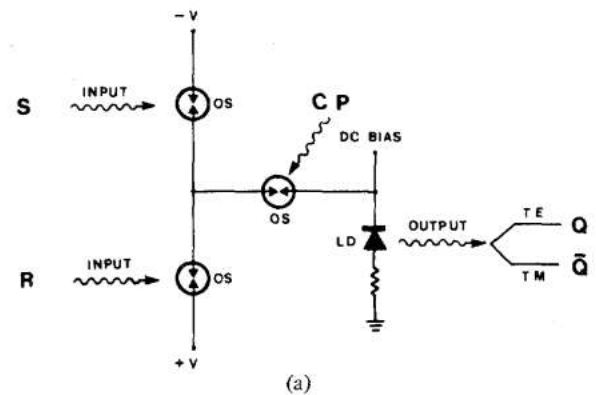

Fig. 10. (a) The circuit of an optical *S-R* flip-flop consisting of three optoelectronic switches. (b) An alternative circuit using two photodetectors. PD is the photodetector, OS the optoelectronic switch, and LD the polarization-bistable laser diode. (c) Logic diagram and characteristic table of the *S-R* flip-flop.

no sampled output pulse to trigger the laser. The laser stays in its previous state Q_n . If $S = 0$ and $R = 1$ at the moment of a clock pulse, a positive output pulse propagates through the third switch. The laser output is switched from TE to TM. If the laser originally operates in the TM mode, it stays in the TM mode at the triggering of a positive pulse. Therefore, the condition $S = 0$ and $R = 1$ always results in $Q_{n+1} = 0$ ($\overline{Q}_{n+1} = 1$). If $S = 1$ and $R = 0$, a negative pulse is sampled. The laser is triggered to operate in the TE mode ($Q_{n+1} = 1$). The condition $S = 1$ and $R = 1$ is forbidden in conventional electronic *S-R* flip-flops because it results in an indeterminate state as indicated by the question mark in Fig. 10(c). However, in our optical *S-R* flip-flop, we have experimentally observed that when the two input ports are well-balanced, the condition $S = 1$ and $R = 1$ generates $Q_{n+1} = Q_n$ and is not indeterminate. The

S-R FLIP-FLOP OPERATION

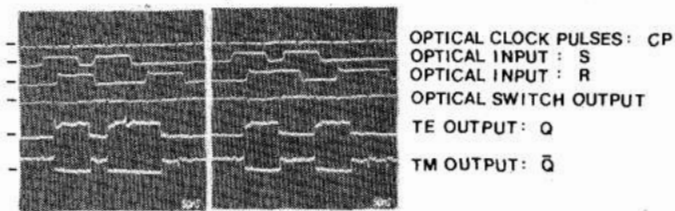

Fig. 11. Operation of the optical *S-R* flip-flop shown in Fig. 10(b). Trace 4 is the inverted electrical output of the optoelectronic switch activated by the clock pulses. All other traces are optical signals.

logic diagram and the characteristic table of the *S-R* flip-flop are shown in Fig. 10(c).

In our experimental demonstration of the *S-R* flip-flop operation, an alternative circuit shown in Fig. 10(b) was used, in which the two optoelectronic switches at the input ports were substituted with avalanche photodetectors (PD) because only one optoelectronic switch was available to us. The input signals, *S* and *R*, are generated by two AlGaAs/GaAs stripe-geometry semiconductor lasers with pulsed current injection. The optical clock pulses are generated by an AlGaAs/GaAs transverse-junction-stripe laser driven by a train of current pulses. The optoelectronic switch consists of a Cr-doped semi-insulating GaAs substrate with a gap in the top metallization. The switching efficiency was rather low (<1 percent) because the switch was not designed for this application. An amplifier was, therefore, used to enhance the electrical output of the optoelectronic switch before the signal was used to trigger the polarization-bistable laser. As will be discussed later, the amplifier is not needed if well-designed switches are used. The photographs in Fig. 11 show the operation of the optical *S-R* flip-flop. Notice that all the traces are optical signals from semiconductor lasers except for trace 4, which represents the inverted electrical output pulses from the optoelectronic switch which trigger the laser diode, LD. It can be clearly seen from the traces in Fig. 11 that the TE and TM optical output signals are complementary to each other and that they are *Q* and \bar{Q} outputs of the flip-flop.

B. *D* (Delay or Data) Flip-Flop

Fig. 12(a) shows the circuit of an optical *D* flip-flop consisting of two optoelectronic switches. If *D* = 0 at the moment a clock pulse occurs, the switch at the input port is not conducting and a positive voltage is applied to the sampling optoelectronic switch. The clock pulse activates the sampling optoelectronic switch to transmit a positive current pulse which triggers the laser to operate in the TM mode, thus, $Q_{n+1} = 0$. If *D* = 1 when the clock pulse occurs, the input switch is conducting. Since $V_a > V_b$, a negative current pulse is then generated at the sampling switch by the clock pulse and triggers the laser to operate in the TE mode. Thus, $Q_{n+1} = 1$ when *D* = 1. Fig. 12(b) shows an alternative circuit using a photodetector at the input port. Fig. 12(c) shows the logic diagram and the characteristic table of a *D* flip-flop. This type of flip-flop is useful when transferring data from one source to another and is the simplest type of device from a control point of view.

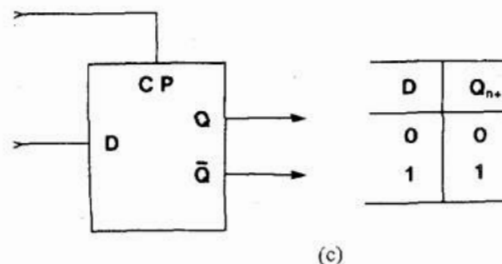
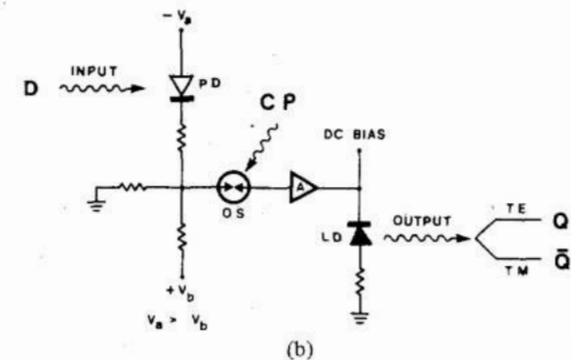
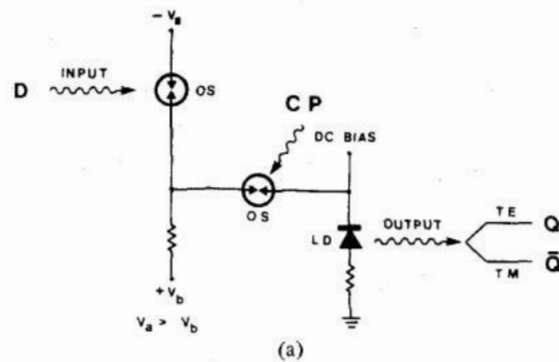

Fig. 12. (a) and (b) Circuit diagrams. (c) Logic diagram and characteristic table of an optical *D* flip-flop.

The photograph in Fig. 13 demonstrates the operation of the optical *D* flip-flop with the circuit of Fig. 12(b). All the traces are optical signals from semiconductor lasers except for trace 3, which represents the inverted electrical output pulses from the sampling optoelectronic switch activated by the clock pulse train.

C. *J-K* Flip-Flop

The circuit of an optical *J-K* flip-flop, which consists of five optoelectronic switches and two optical feedback lines, is shown in Fig. 14(a). The TE and TM optical output signals are fed back to control OS4 and OS1, respectively. OS2 at the *J* input port and OS1 are connected in series and are biased with a negative voltage, $-V$, while OS3 at the *K* input port and OS4 are connected in series and are biased with a positive voltage, $+V$. The fifth optoelectronic switch OS5 is activated by opti-

D FLIP-FLOP OPERATION

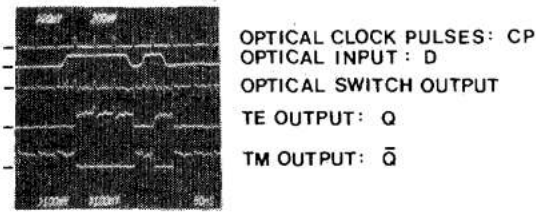

Fig. 13. Operation of the optical *D* flip-flop shown in Fig. 12(b). The third trace from the top is the inverted electrical output of the optoelectronic switch activated by the clock pulses. All other traces are optical signals.

J-K FLIP-FLOP OPERATION

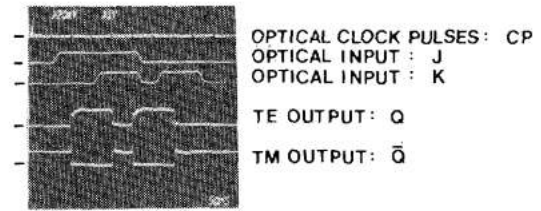

Fig. 15. Operation of the optical *J-K* flip-flop shown in Fig. 14(b). All traces are optical signals.

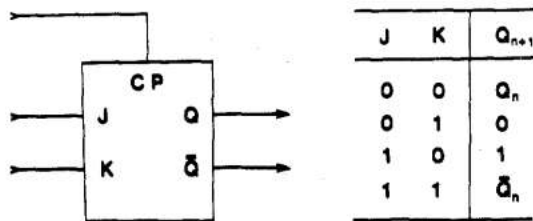
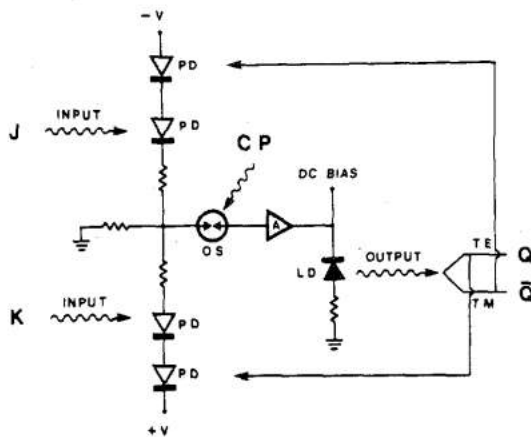
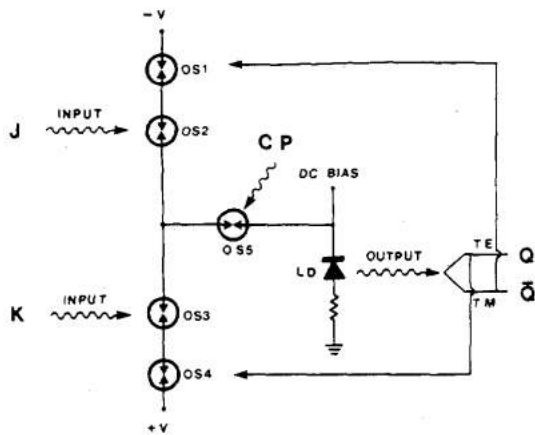

Fig. 14. (a) and (b) Circuit diagrams. (c) Logic diagram and characteristic table of an optical *J-K* flip-flop.

cal clock pulses to sample the input voltage from these two arms. Consider the moment a clock pulse occurs at OS5. If $J = 0$ and $K = 0$, no input voltage is applied to OS5 and no triggering pulse is switched. The laser is not triggered and will stay in its previous state Q_n . If $J = 0$ and $K = 1$, OS2 is open and OS3 is conducting. If $Q_n = 0$, there is no TE feedback to turn on OS4. Again, no input voltage is applied to OS5 and the laser stays in $Q_{n+1} = Q_n = 0$. If $Q_n = 1$, the TE output is fed back to turn on OS4. A positive voltage is applied to OS5 which then switches out a positive pulse in synchronism with the clock pulse. The laser is then triggered to switch into the TM mode, resulting in $Q_{n+1} = 0$. Similarly, the condition $J = 1$ and $K = 0$ always results in $Q_{n+1} = 1$. When $J = 1$ and $K = 1$, both OS2 and OS3 are conducting. If $Q_n = 0$, a TM feedback signal turns on OS1 and a negative pulse will be switched by OS5 in synchronism with the clock pulse. The laser is then triggered to switch to the TE mode, resulting in $Q_{n+1} = 1$. If $Q_n = 1$, OS4 is turned on by a TE feedback signal and a positive pulse is switched by OS5 to trigger the laser into the TM mode. The output thus switches to $Q_{n+1} = 0$ at the time the clock pulse occurs. Therefore, the output always changes state at the arrival of a clock pulse when $J = 1$ and $K = 1$. Fig. 14(c) shows the logic diagram and the characteristic table of the *J-K* flip-flop.

Fig. 15 demonstrates the operation of the optical *J-K* flip-flop with an alternative circuit shown in Fig. 14(b), in which OS1-OS4 are replaced with photodetectors under reverse bias and an amplifier is used to amplify the electrical output of OS5 as in Fig. 10(b). All the traces in Fig. 15 are optical signals from semiconductor lasers.

D. *T* (Toggle or Complement) Flip-Flop

The circuit of an optical *T* flip-flop is shown in Fig. 16(a) which consists of four optoelectronic switches and two optical feedback lines. When a clock pulse arrives, if $T = 0$, OS3 is open and no triggering voltage pulse can propagate through OS4. The laser stays in its previous state, $Q_{n+1} = Q_n$. If $T = 1$, OS3 is conducting. If $Q_n = 0$, a TM feedback signal turns on OS1. A negative pulse propagates through OS4 under the excitation of a clock pulse. This triggers the laser to switch to the TE mode, resulting in $Q_{n+1} = \bar{Q}_n = 1$. Similarly, if $T = 1$ and $Q_n = 1$, then $Q_{n+1} = \bar{Q}_n = 0$. Therefore, the *T* flip-flop always toggles or changes state with every input clock pulse as long as the input *T* is at logic 1. The logic diagram and the characteristic table of the *T* flip-flop are shown in Fig. 16(c). In an alternative circuit, OS1 and OS2 can be replaced with two

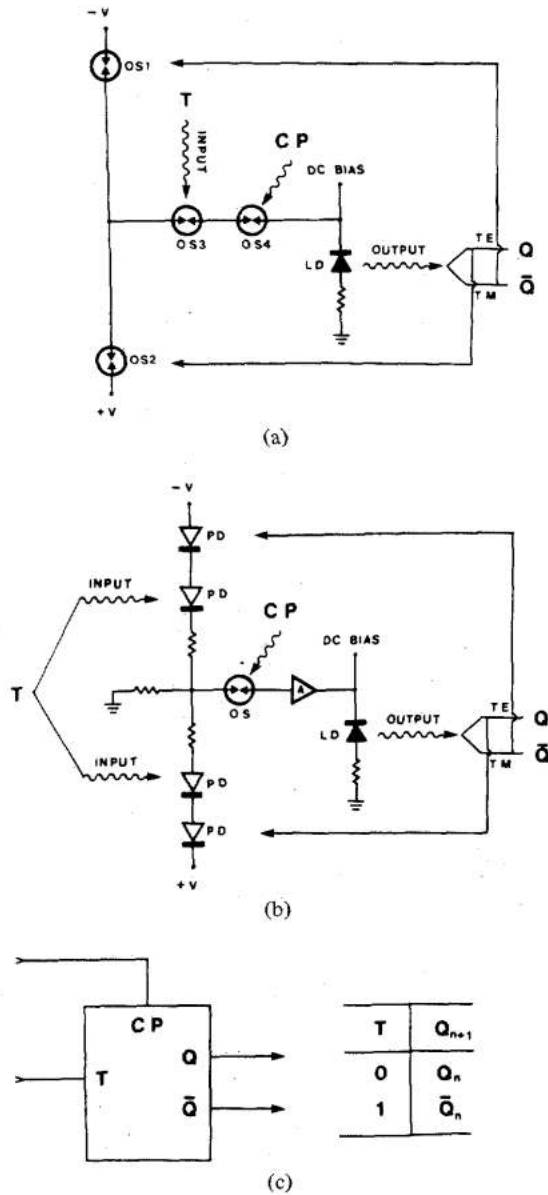

Fig. 16. (a) and (b) Circuit diagrams. (c) Logic diagram and characteristic table of an optical T flip-flop.

T FLIP-FLOP OPERATION

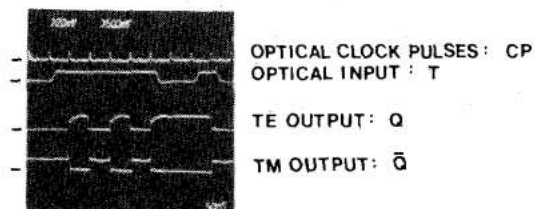

Fig. 17. Operation of the optical T flip-flop shown in Fig. 16(b). All traces are optical signals.

reverse-biased photodetectors. However, the optoelectronic switch OS3 at the T input port cannot be substituted with a photodetector. Since only one optoelectronic switch is available to us, the operation of the optical T flip-flop as is demonstrated in Fig. 17 was performed with another alternative circuit shown in Fig. 16(b).

VI. DISCUSSION AND CONCLUSIONS

Based on the polarization-bistable semiconductor lasers, we have proposed the schemes for a complete set of optical logic gates and clocked optical flip-flops with very simple circuitry which consists of high-speed optoelectronic switches and/or photodetectors. We have also demonstrated the operation of each of the logic gates and flip-flops using optical input signals and optical clock pulses generated by conventional semiconductor lasers. Limited by the speed (rise time and fall time) of the pulse generators used to drive the semiconductor lasers which generate the optical input signals, we were not able to directly demonstrate subnanosecond operations of these devices. However, independent switching operations of the polarization-bistable lasers with fast-rising current pulses did show instrument-limited mode switching time of the laser on the order of 1 ns [6], [7]. The response times of optoelectronic switches and photodetectors are a few hundred picoseconds. The overall switching speed of the devices should be limited by the polarization-bistable laser to <1 ns. Our schemes are therefore capable of working at a clock rate well over 100 MHz if very fast rising and falling optical input signals are used. Optical signal processing at a data rate close to 1 Gbit/s can be achieved.

On the basis of current fabrication technology, each of the proposed circuits can be monolithically integrated. Because of the simplicity of the circuitry, the flip-flops and the logic gates will have similar small integrated sizes and high speed. Because the input, output, and the clock pulses are not directly optically coupled, the operations of these devices do not depend on the coherence of the optical pulses, nor do they require close frequency-matching of optical signals at various stages. By properly choosing the semiconductor materials for the optoelectronic switches, they can operate with input, output, and clock pulses at the same wavelength, or at different wavelengths. By designing the schemes to work at the same wavelength, they can be used as the building blocks of an optical signal processing system based on a single substrate material. If the devices are designed to operate with input, output, and clock pulses at different wavelengths, they can be used as optical logic interface components to connect systems working at various wavelengths. For example, with input signals in the 8000 Å wavelength range and output signals at 1.3 μm, the devices can transfer information from a local AlGaAs/GaAs-based optical signal processing system to an InGaAsP/InP-based long distance optical communication system in addition to performing their specific logic or memory operations.

In addition to the compatibility with monolithic integration, the schemes demonstrated in this paper have an attractive feature of being operable at practical power levels of semiconductor lasers. Consider optoelectronic switches made of semiinsulating GaAs with the following parameters: n (refractive index) = 3.6, $(\mu_n + \mu_p)$ (sum of electron and hole mobilities) = 2000 cm²/V⁻¹ s⁻¹, l (the gap between electrodes) = 3 μm, $h\nu$ (incident photon energy) = 1.5 eV, the conductance across the gap is [14] $G = 1 \times 10^{-2} \Omega^{-1}/\mu\text{J}$. To switch the output of a polarization-bistable laser within 1 ns, the current pulse needs to be 40 mA, or 2 V across 50 Ω, [7]. Such voltage can be delivered by the circuit with two optoelectronic switches connected in

series shown in Fig. 10(a), using 20 V dc bias and 2 pJ ($=2$ mW \times 1 ns) energy of the semiconductor laser pulse. In this case, an amplifier in the circuit is not necessary.

The polarization-bistable lasers change states by switching the output between TE and TM modes with very high contrast ratios. Direct complement functions are obtainable from TE and TM output signals from the same laser, and the 1 and 0 states have very high contrast ratios. In addition to these advantages of the polarization-bistable lasers, the basic principles of our schemes are also applicable to other types of bistable lasers.

REFERENCES

- [1] H. F. Taylor, "Guided wave electrooptic devices for logic and computation," *Appl. Opt.*, vol. 17, p. 1493, 1978.
- [2] J. C. Campbell, A. G. Dentai, J. A. Copeland, and W. S. Holden, "Optical AND gate," *IEEE J. Quantum Electron.*, vol. QE-18, pp. 992-995, June 1982.
- [3] A. Lattes, H. A. Haus, F. J. Leonberger, and E. P. Ippen, "An ultrafast all-optical gate," *IEEE J. Quantum Electron.*, vol. QE-19, pp. 1718-1723, Nov. 1983.
- [4] W. T. Tsang, N. A. Olsson, and R. A. Logan, "Optoelectronic logic operations by cleaved-coupled-cavity semiconductor lasers," *IEEE J. Quantum Electron.*, vol. QE-19, pp. 1621-1625, Nov. 1983.
- [5] K. Okumura, Y. Ogawa, H. Ito, and H. Inaba, in *Proc. 13th Int. Quantum Electron. Conf.*, Anaheim, CA, June 1984, paper TuBB2.
- [6] Y. C. Chen and J. M. Liu, "Direct polarization switching in semiconductor lasers," *Appl. Phys. Lett.*, vol. 45, p. 604, 1984.
- [7] —, "Polarization bistability in semiconductor lasers," *Appl. Phys. Lett.*, vol. 46, p. 16, 1985.
- [8] F. J. Leonberger and P. F. Moulton, "High speed InP optoelectronic switch," *Appl. Phys. Lett.*, vol. 35, p. 712, 1979; see also A. G. Foyt, F. J. Leonberger, and R. C. Williamson, "Picosecond InP optoelectronic switches," *Appl. Phys. Lett.*, vol. 40, p. 447, 1982.
- [9] E. O. Göbel, G. Veith, J. Kuhl, H. U. Habermeire, L. Lübke, and A. Perger, "Direct gain modulation of a semiconductor laser by a GaAs picosecond optoelectronic switch," *Appl. Phys. Lett.*, vol. 42, p. 25, 1983.
- [10] C. Harder, K. Y. Lau, and A. Yariv, "Bistability and pulsations in semiconductor lasers with inhomogeneous current injection," *IEEE J. Quantum Electron.*, vol. QE-18, 1351-1361, Mar. 1982.
- [11] N. A. Olsson, W. T. Tsang, R. A. Logan, I. P. Kaminow, and J. S. Ko, "Spectral bistability in coupled cavity semiconductor lasers," *Appl. Phys. Lett.*, vol. 44, p. 375, 1984.
- [12] Y. C. Chen and J. M. Liu, "Temperature-dependent polarization behavior of semiconductor lasers," *Appl. Phys. Lett.*, vol. 45, p. 731, 1984.
- [13] See for example, J. Millman and C. C. Halkias, *Integrated Electronics: Analog and Digital Circuits and Systems*. New York: McGraw-Hill, 1972, ch. 17.
- [14] A. M. Johnson and D. H. Auston, "Microwave switching by picosecond photoconductivity," *IEEE J. Quantum Electron.*, vol. QE-11, p. 283, 1975.

Jai-Ming Liu (M'83), for a photograph and biography, see p. 277 of the March 1985 issue of this JOURNAL.

Ying-Chih Chen (M'80), for a photograph and biography, see p. 277 of the March 1985 issue of this JOURNAL.