

Institute for Software Integrated Systems
Vanderbilt University
Nashville, Tennessee, 37235

Digital Passive Attitude and Altitude
Control Schemes for Quadrotor
Aircraft

Nicholas Kottenstette, and Joseph Porter

TECHNICAL REPORT

ISIS-08-911 Original: 11/2008,
Revised:3/31/2010

NOTICE: This is the author's version of a work that will appear at The Seventh IEEE International Conference on Control and Automation (ICCA 2009) at Christchurch, New Zealand. Changes resulting from the publishing process, such as peer review, editing, corrections, structural formatting, and other quality control mechanisms may not be reflected in this document. Changes may have been made to this work since it was submitted for publication. Please see IEEE for the definitive version. (correction to Corollary 2 added in latest revision).

Digital Passive Attitude and Altitude Control Schemes for Quadrotor Aircraft.

Nicholas Kottenstette*, Joseph Porter*
*ISIS/Vanderbilt University

Abstract—This paper presents a formal method to design a digital inertial control system for quad-rotor aircraft. In particular, it formalizes how to use approximate passive models in order to justify the initial design of passive controllers. Fundamental limits are discussed with this approach – in particular, how it relates to the control of systems consisting of cascades of three or more integrators in which input actuator saturation is present. Ultimately, two linear proportional derivative (PD) passive controllers are proposed to be combined with a non-linear saturation element. It is also shown that yaw control can be performed independently of the inertial controller, providing a great deal of maneuverability for quad-rotor aircraft. A corollary, based on the sector stability theorem provided by Zames and later generalized for the multiple-input-output case by Willems, provides the allowable range of k for the linear negative feedback controller kI in which the dynamic system $H_1 : x_1 \rightarrow y_1$ is inside the sector $[a_1, b_1]$, in which $-\infty < a_1$, $0 < b_1 \leq \infty$, and $b_1 > a_1$. This corollary provides a formal method to verify stability, both in simulation and in operation for a given family of inertial set-points given to the quad-rotor inertial controller. The controller is shown to perform exceptionally well when simulated with a detailed model of the STARMAC, which includes blade flapping dynamics.

I. INTRODUCTION

Quadrotor helicopters are agile aircraft which are lifted and propelled by four rotors. Unlike traditional helicopters, they do not require a tail-rotor to control yaw and can use four smaller fixed-pitch rotors. Smaller rotors allow these vehicles to achieve higher velocities before blade flapping effects begin to introduce instability and limit performance. However, without an attitude control system it is difficult if not impossible for a human to successfully fly and maneuver such a vehicle. Thus, most research has focused on small unmanned aerial vehicles in which advanced embedded control systems could be developed to control these aircraft. In [1] a Lyapunov-like control approach is used to develop a non-linear inertial controller which relies on robust stability results involving control elements with nested saturation blocks [2], [3]. [4] shows that a simple, model-independent quaternion-based proportional derivative (PD) controller performs quite well in controlling attitude as compared to other more involved non-linear controllers. In [5], image based visual servo control algorithms are presented which exploit passivity-like properties of the dynamic model in order to derive Lyapunov control algorithms which rely on backstepping techniques. All the above papers, and others

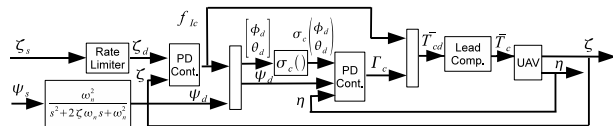

Fig. 1. Proposed quad-rotor control system.

contain fairly detailed models which guide their overall control design. Most of the Lyapunov control proposals typically are fairly computationally expensive and it is not clear how robust they are to model uncertainties. In particular, all of the above papers appear to neglect a significant time lag characteristic related to the motor thrust command and the corresponding thrust which results due to the acceleration of the air column. With [1] as an exception, almost all other model descriptions neglect the limited control thrust due to motor saturation. More significant all model descriptions in previous literature neglect digital platform implementation effects such as sampling delay, quantization, etc. In order to address these effects we propose that Corollary 2 provides a formal manner to *verify* that the sector stability condition is satisfied for a given family of inertial position inputs which can easily be verified through both simulation and field testing.

As depicted in Fig. 1 we propose to use two PD controllers (denoted as PD Cont. in Fig. 1). The inner-most loop controller is a 'fast' PD attitude controller in which attitude is described by Euler angles η . The attitude controller design is initially justified by assuming that the controller and dynamics are passive. Next, we further assume that the resulting attitude controller is 'fast' enough that we can close the loop with a second PD inertial controller (the inertial position is denoted ζ). These initial assumptions allow us to propose a control system which will guarantee an overall L_2^m -stable (or bounded) system. However, this initial design will not work due to the following limitations: First, there is a significant lag between rotor thrust commands and the resulting change in thrust. The lag is apparently due to the acceleration of the air columns above their respective rotors [6]. In order to compensate for this lag we add an additional lead compensator to minimize this effect (denoted as Lead Comp. in Fig. 1). Second, the rotors can only apply a fixed range of thrust (denoted $\sigma(\bar{T}_c)$ in which \bar{T}_c denotes the corresponding thrust command vector) due to motor driver voltage limits. It can be inferred from [1] that the relationship between roll (ϕ), pitch (θ), and thrust T to the corresponding

⁰Contract/grant sponsor (number): NSF (NSF-CCF-0820088)
Contract/grant sponsor (number): Air Force (FA9550-06-1-0312).

desired inertial position can be approximated as a cascade of four integrators subject to input actuator saturation. [2] shows that a saturated actuator input makes it impossible to implement a linear control law (such as using two PD controllers) in order to globally stabilize a system which consists of cascades of three or more integrators. However, by choosing to limit the linear control output by using appropriately designed saturation blocks there does exist a linear control law such that global stability can be achieved [2, Theorem 2.2]. This fundamental limitation essentially requires us to naturally limit the range of attitude commands to our inner-loop PD controller in terms of pitch and roll to the interval $[-\frac{\pi}{4}, \frac{\pi}{4}]$ using the saturation function which is denoted as $\sigma_c(\cdot)$ in Fig. 1. In simulations, the control of our quad-rotor aircraft worked quite well until the velocity reached a point in which significant rotor flapping effects began to destabilize the system. We chose to limit the maximum velocities by adding a position rate change limiter (depicted as 'Rate Limiter' in Fig. 1) to the desired inertial position set-point (denoted as ζ_s). The rate change limiter includes an additional second-order pre-filter applied to ζ_s in order to minimize overshoot. A similar filter is applied to the yaw set-point ψ_s as well. Other non-ideal effects – non-passive attitude coordinates (Euler angles η), quantization, single-precision floating point math errors, and sample-rate delay can be addressed by using Corollary 2 to *verify* that the sector stability condition is satisfied over a large family of inertial position inputs.

Section II introduces a few definitions regarding passivity, boundedness, and corollaries regarding stability. Section III provides an appropriate model to describe the quad-rotor dynamics as it relates to statements regarding the design of a controller for the quad-rotor. Section IV provides a description of our control implementation and corresponding stability arguments which lead us to an overall feasible control design. Section V provides a detailed discussion of a detailed simulation of our control system used to control a detailed model of the STARMAC quad-rotor helicopter which includes highly non-linear blade-flapping effects [6]. Section VI presents our conclusions and points to future research directions.

II. PASSIVITY AND SECTOR STABILITY

In order to discuss the (boundedness) or stability properties of the quad-rotor with our proposed control system we recall the following nomenclature, definitions and present Corollary 2 in order to *verify* stability. Let \mathcal{T} be the set of times of interest in which $\mathcal{T} = \mathbb{R}^+$ for continuous-time signals and $\mathcal{T} = \mathbb{Z}^+$ for discrete-time signals. Let \mathcal{V} be a linear space \mathbb{R}^m and denote as \mathcal{H} the space of all functions $u : \mathcal{T} \rightarrow \mathcal{V}$ which satisfy the following:

$$\|u\|_2^2 = \int_0^\infty u^\top(t)u(t)dt < \infty, \quad (1)$$

for continuous-time systems (L_2^m), and

$$\|u\|_2^2 = \sum_0^\infty u^\top(i)u(i) < \infty, \quad (2)$$

for discrete-time systems (l_2^m). Similarly, we will denote by \mathcal{H}_e the extended space of functions ($u : \mathcal{T} \rightarrow \mathcal{V}$) by introducing the truncation operator:

$$x_T(t) = \begin{cases} x(t), & t < T, \\ 0, & t \geq T \end{cases}$$

for continuous time, and

$$x_T(i) = \begin{cases} x(i), & i < T, \\ 0, & i \geq T \end{cases}$$

for discrete time. The extended space \mathcal{H}_e satisfies the following:

$$\|u_T\|_2^2 = \int_0^T u^\top(t)u(t)dt < \infty; \quad \forall T \in \mathcal{T} \quad (3)$$

for continuous time systems (L_{2e}^m), and

$$\|u_T\|_2^2 = \sum_0^{T-1} u^\top(i)u(i) < \infty; \quad \forall T \in \mathcal{T} \quad (4)$$

for discrete time systems (l_{2e}^m).

Definition 1: A dynamic system $H : \mathcal{H}_e \rightarrow \mathcal{H}_e$ is L_2^m stable if

$$u \in L_2^m \implies Hu \in L_2^m. \quad (5)$$

in which $Hu = y$ corresponds to the dynamic output of the system, and the value of Hu at time t will be denoted as $Hu(t) = y(t)$.

Definition 2: A dynamic system $H : \mathcal{H}_e \rightarrow \mathcal{H}_e$ is l_2^m stable if

$$u \in l_2^m \implies Hu \in l_2^m. \quad (6)$$

in which $Hu = y$ corresponds to the dynamic output of the system, and the value of Hu at discrete time i will be denoted as $Hu(i) = y(i)$.

The inner product over the interval $[0, T]$ for continuous time is denoted as follows:

$$\langle y, u \rangle_T = \int_0^T y^\top(t)u(t)dt$$

similarly the inner product over the discrete time interval $\{0, 1, \dots, T-1\}$ is denoted as follows:

$$\langle y, u \rangle_T = \sum_0^{T-1} y^\top(i)u(i).$$

For simplicity of discussion we note the following equivalence for our inner-product space:

$$\langle (Hu)_T, u_T \rangle = \langle (Hu)_T, u \rangle = \langle Hu, u_T \rangle = \langle Hu, u \rangle_T.$$

Definition 3: Assuming that $Hu(0) = y(0) = 0$, then a dynamic system $H : \mathcal{H}_e \rightarrow \mathcal{H}_e$ is (strictly) inside the sector $[a, b]$, $b > 0$, $a \leq b$, $\epsilon > 0$ if

$$\|y_T\|_2^2 - (a+b)\langle y, u \rangle_T + ab\|u_T\|_2^2 \leq 0 \quad (\leq -\epsilon\|u_T\|_2^2) \quad (7)$$

Definition 4: Assuming that $Hu(0) = y(0) = 0$, then a dynamic system $H : \mathcal{H}_e \rightarrow \mathcal{H}_e$ is (strictly) interior conic with center $c \in \mathbb{R}$ and radius r , $\epsilon \geq 0$ if

$$\|(Hu - cu)_T\| \leq r\|u_T\| \quad (\leq (r + \epsilon)\|u_T\|) \quad (8)$$

Corollary 1: A dynamic system $H : \mathcal{H}_e \rightarrow \mathcal{H}_e$ is (strictly) interior conic with center $c \in \mathbb{R}$ and radius $r, \epsilon \geq 0$ if and only if H is (strictly) inside the sector $[a, b]$ with $a = c - r$ and $b = c + r$ ($c = \frac{a+b}{2}$, $r = \frac{b-a}{2}$).

Remark 1: Corollary 1 follows directly from [7, Theorem 2.8] and originally developed for the single-input-output case in [8].

Property 1: Assume the following dynamic systems $H : u \rightarrow y$, $H_1 : u_1 \rightarrow y_1$ are inside their respective sectors $[a, b]$, $[a_1, b_1]$, and $k \geq 0$ is a constant then:

- (i) I can be said to be inside $[1, 1]$, $[\epsilon, 1] \forall 0 < \epsilon \leq 1$, or strictly inside $[0, 1 + \epsilon] \forall 0 < \epsilon \leq 1$.
- (ii) kH is inside $[ka, kb]$
- (iii) Sum Rule: $(H + H_1)$ is inside $[a + a_1, b + b_1]$.

Remark 2: The first two properties are obvious, and follow the properties listed for the single-input-output case stated in [8, Section 4.2]. The Sum Rule is not at all obvious when using the sector constraint, however as shown for the single-input-output case in [8] we can establish that $(H + H_1)$ is interior conic with center $\frac{1}{2}(b + b_1 + a + a_1)$ and radius $\frac{1}{2}(b + b_1 - a - a_1)$ which is equivalent to being inside the sector $[a + a_1, b + b_1]$ (due to Corollary 1).

$$\begin{aligned} & \|((H + H_1)u - \frac{1}{2}((b + a) + (b_1 + a_1))u)_T\| \leq \\ & \| (Hu - \frac{1}{2}(b + a)u)_T \| + \| (H_1u - \frac{1}{2}(b_1 + a_1)u)_T \| \\ & \text{due to the triangle inequality.} \\ & \leq \frac{1}{2}(b - a)\|u_T\| + \frac{1}{2}(b_1 - a_1)\|u_T\| \\ & \leq \frac{1}{2}(b + b_1 - a - a_1)\|u_T\|. \end{aligned}$$

The second to last inequality results when we recall that $H_{(1)}$ is interior conic with center $c_{(1)} = \frac{a_{(1)} + b_{(1)}}{2}$ and radius $r_{(1)} = \frac{b_{(1)} - a_{(1)}}{2}$.

Definition 5: If we assume that $Hu(0) = 0$, then if H is inside the sector:

- i) $[0, \infty]$ it is a passive (positive) system
- ii) $[0, b]$, $b < \infty$, it is strictly output passive
- iii) $[\epsilon, \infty]$, $\epsilon > 0$ or strictly inside the sector $[0, \infty]$ it is strictly input passive
- iv) $[a, b]$, $a > 0$, $b < \infty$ it is strictly input-output passive
- v) $[a, b]$, $-\infty < a$, $b < \infty$ it is a bounded (l_2^m -stable for discrete time, or L_2^m -stable for continuous time) system.

Let us denote the state of a system as $x \in \mathbb{R}^n$. Let the supply rate $r(u, y)$ have the following form:

$$r(u, y) = y^T(t)u(t) - \frac{1}{(a+b)}y^T(t)y(t) - \frac{ab}{(a+b)}u^T(t)u(t) \quad (9)$$

for the continuous time case or

$$r(u, y) = y^T(i)u(i) - \frac{1}{(a+b)}y^T(i)y(i) - \frac{ab}{(a+b)}u^T(i)u(i) \quad (10)$$

for the discrete time case.

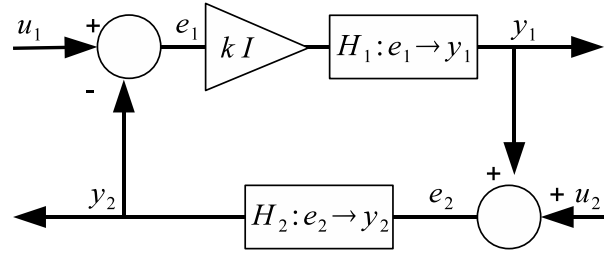

Fig. 2. Bounded system $H : [u_1^T, u_2^T]^T \rightarrow [y_1^T, y_2^T]^T$.

Remark 3: In a slightly less general manner as was done in [9], let us assume that we can describe our system H in terms of the following state-space equations:

$$\begin{aligned} \dot{x}(t) &= f(x(t), u(t)), \quad x(0) = x_o, \quad t > 0 \\ y(t) &= h(x, u(t)) \end{aligned}$$

for the continuous-time case, or

$$\begin{aligned} x(i+1) &= f(x(i), u(i)), \quad x(0) = x_o, \quad i \geq 0 \\ y(i) &= h(x(i), u(i)) \end{aligned}$$

for the discrete-time case. Then if there exists a *storage function* $V(x) : \mathbb{R}^n \rightarrow \mathbb{R} > 0$, $\forall x \neq 0$ and $V(0) = 0$ in which there exists a $b > 0$, $a \leq b$ and:

- 1) $\dot{V}(x) \leq r(u, y)$, and $\dot{V}(x)$ is continuously differentiable, then H is inside the sector $[a, b]$ for the continuous-time case.
- 2) $V(x(i+1)) - V(x(i)) \leq r(u, y)$, $\forall i \in \mathcal{T}$, then H is inside the sector $[a, b]$ for the discrete-time case.

The following Theorem serves as the basis for proposing the linear PD controllers depicted in Fig. 1. It is a weaker form of the passivity theorem [10] which considers when the input $u_2 \neq 0$. Parts of the theorem have appeared in [11]–[14], we generalize it slightly by adding kI to the structure.

Theorem 1: Assume that the combined system $H : u_1 \rightarrow y_1$, $u_2 = 0$ depicted in Fig. 2 has $0 < k < \infty$ and consists of two dynamic systems $H_1 : u_1 \rightarrow y_1$ and $H_2 : u_2 \rightarrow y_2$ which are either:

- i) respectively inside the sector $[a_1, b_1]$, $a_1 = 0, b_1 < \infty$ (H_1 is strictly output passive) and inside the sector $[0, \infty]$ (H_2 is passive) or
- ii) respectively inside the sector $[a_1, b_1]$, $a_1 = 0, b_1 = \infty$ (H_1 is passive) and inside the sector $[a_2, \infty]$ (H_2 is strictly input passive),

then $H : u_1 \rightarrow y_1$ is strictly output passive and bounded (l_2^m stable for the discrete time case, or L_2^m stable for the continuous time case).

Proof: First we recall the property that the combined system kH_1 is inside the sector $[ka_1, kb_1]$ and that $e_1 = u_1 - y_2$ therefore

i)

$$\langle y_1, e_1 \rangle_T \geq \frac{1}{kb_1} \|(y_1)_T\|_2^2$$

$$\langle y_1, u_1 \rangle_T \geq \langle y_2, y_1 \rangle_T + \frac{1}{kb_1} \|(y_1)_T\|_2^2$$

$$\langle y_1, u_1 \rangle_T \geq \frac{1}{kb_1} \|(y_1)_T\|_2^2$$

in which the final (strictly output passive) inequality results since H_2 is passive.

ii)

$$\begin{aligned} \langle y_1, e_1 \rangle_T &\geq 0 \\ \langle y_1, u_1 \rangle_T &\geq \langle y_2, y_1 \rangle_T \\ \langle y_1, u_1 \rangle_T &\geq a_2 \|(y_1)_T\|_2^2 \end{aligned}$$

in which the final (strictly output passive) inequality results since H_2 is strictly input passive. \blacksquare

Remark 4: Theorem 1-i provides the basis for constructing asymptotic stabilizing controllers for systems which can be described as a cascade of two passive systems $H_c = H_1 H_2$. The first half of the system H_1 is rendered strictly output passive by closing the inner-loop in a manner which satisfies Theorem 1-ii, then the outer-loop is closed with the output of H_2 .

Although, Theorem 1 provides a sound and intuitive basis to construct stable attitude control systems, it does not allow us to provide a formal way to verify the effects of cascading a 'fast' attitude controller with a slower PD inertial controller. The following corollary provides a way to verify stability when passivity constraints of the closed loop system can not meet the previously mentioned constraints. In particular we are concerned with the case when H_1 is inside the sector $[a_1, \infty]$ in which $-\infty < a_1 < 0$.

Corollary 2: Assume that the combined dynamic system $H : [u_1^T, u_2^T]^T \rightarrow [y_1^T, y_2^T]^T$ depicted in Fig. 2 consists of two dynamic systems $H_1 : u_1 \rightarrow y_1$ and $H_2 : u_2 \rightarrow y_2$ which are respectively inside the sector $[a_1, b_1]$ and strictly inside the sector $[0, 1 + \epsilon]$, for all $\epsilon > 0$. Then H is bounded (L_2^m stable for the continuous time case or l_2^m stable for the discrete time case) if:

$$\begin{aligned} -\frac{1}{\max\{|a|, b\}} < k < -\frac{1}{a_1}, \quad \text{if } a_1 < 0 \\ -\frac{1}{b} < k < \infty, \quad \text{otherwise.} \end{aligned}$$

Remark 5: The upper bound on k for Corollary 1 follows directly from [7, Corollary 4.3.3, case 3] for the multi-input-output case and [8, Theorem 2a, case 2] for the single-input-output case. The lower-bound on k is a direct result of applying the small-gain condition.

III. QUAD-ROTOR MODEL

Let $\mathcal{I} = \{e_N, e_E, e_D\}$ (North-East-Down) denote the inertial frame, and $\mathcal{A} = \{e_x, e_y, e_z\}$ denote a frame rigidly attached to the aircraft as depicted in Fig. 3. Let ζ denote inertial position, η denote the vector of Euler angles $\eta^T = [\phi, \theta, \psi]^T$ in which ϕ is the roll, θ is the pitch and ψ is the yaw. $R(\eta) \in \text{SO}(3)$ is the orthogonal rotation matrix ($R^T R = I$) which describes the orientation of the airframe in which $R(\eta)$ describes the rotation matrix from the inertial frame to the body frame as is the convention used in [15], [16]. The rotation matrix allows coordinates relative to the inertial frame such as inertial angular velocity ω_I to

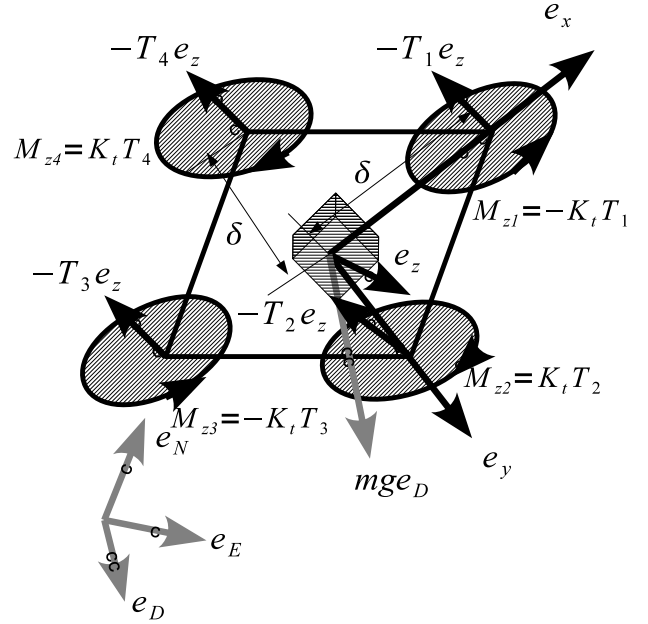

Fig. 3. UAV with depiction of inertial and body frames.

coordinates relative to the body frame such as the angular velocity ω as follows

$$\omega_I = R^T(\eta)\omega.$$

The standard equations of motion are as follows:

$$\dot{\zeta} = v_I$$

$$m\dot{v}_I = f_I = mge_D - TR^T(\eta)e_z \quad (11)$$

$$I\dot{\omega} = -\omega \times I\omega + \Gamma \quad (12)$$

$$\dot{\eta} = J(\eta)\omega. \quad (13)$$

Which results in a cascade structure, where the inertial force (f_I) depends on the orientation as described by the Euler angle η . (13) relates the frame angular velocity ω to the rate change of the Euler angle $\dot{\eta}$ which depends on the frame control torque $\Gamma^T = [\gamma_x, \gamma_y, \gamma_z]^T$. Each control torque is applied about each corresponding frame axis and positive torque follows the right hand rule. This cascade structure is an overall non-passive structure which has many passive elements. The overall approach in designing a controller for this system will be to take advantage of the passive elements to design a 'fast' passive attitude controller. The closed-loop dynamics of the attitude controller will be fast enough to ignore in order to implement a 'slower' passive inertial position controller which will command the desired attitude in order to reach a desired inertial position relative to the origin of the inertial frame ($\zeta^T = [X, Y, Z]^T$). In the inertial frame, X is the relative distance from the origin along the e_E axis, Y is the relative distance from the origin along the e_N axis, and Z is the relative distance from the origin along the e_D axis. Note that $Z < 0$, $\dot{Z} < 0$ corresponds to the UAV above the inertial origin and flying upward.

Using the shorthand notation $c_x = \cos x$ and $s_x = \sin x$, the rotation matrix $R(\eta)$ is related to the Euler angles as

follows [15, Section 5.6.2]:

$$R(\eta) = \begin{bmatrix} c_\theta c_\psi & c_\theta s_\psi & -s_\theta \\ s_\phi s_\theta c_\psi - c_\phi s_\psi & s_\phi s_\theta s_\psi + c_\phi c_\psi & c_\theta s_\phi \\ c_\phi s_\theta c_\psi + s_\phi s_\psi & c_\phi s_\theta s_\psi - s_\phi c_\psi & c_\theta c_\phi \end{bmatrix} \quad (14)$$

The matrix $J(\eta)$ is the inverse of the Euler angle rates matrix $[E'_{123}(\eta)]^{-1}$ [15, Section 5.6.4] such that

$$J(\eta) = \begin{bmatrix} 1 & \sin \phi \tan \theta & \cos \phi \tan \theta \\ 0 & \cos \phi & -\sin \phi \\ 0 & \frac{\sin \phi}{\cos \theta} & \frac{\cos \phi}{\cos \theta} \end{bmatrix}. \quad (15)$$

In order to determine the range for η in which $J(\eta) > 0$ we recall

Remark 6: [17, Remark 1] Any matrix $A \in \mathbb{R}^{n \times n}$ is positive definite if and only if the symmetric part of A ($B = \frac{1}{2}(A + A^T)$) is positive definite. and

Theorem 2: [17, Theorem 5] If $A \in \mathbb{R}^{n \times n}$ is symmetric, then A is positive definite if and only if $|A_i| > 0$ for $i = 1, \dots, n$ in which $|\cdot|$ denotes the determinant and A_i consists of the ‘‘intersection’’ of the first i rows and columns of A . Using the above two tests we can numerically verify that:

$$J(\eta) > 0, \quad \phi, \theta \in \left[-\frac{29}{90}\pi, \frac{29}{90}\pi\right], \quad \psi \in [-\pi, \pi]. \quad (16)$$

Therefore the relationship between $J(\eta) : \omega_f \mapsto \dot{\eta}$ is passive for the range of η given by (16). Determining passivity properties relating $\omega_f \mapsto \eta$ is a much more challenging task. However, in simulations where $|\omega_{fi}| < 0.5$, and the pitch and roll are conservatively limited within the range of $[-\frac{\pi}{4}, \frac{\pi}{4}]$ the sector bounds are near $[-.004, \infty]$ – which is slightly active when compared to a passive system which would be confined to the sector $[0, \infty]$ [8]. Other attitude parametrization such as the modified Rodrigues parameters possess a passive relationship between angular velocity and attitude which we plan to investigate in the future [13].

Completing our discussion on the UAV dynamics we note that the relationship between inertial acceleration, control thrusts, and the Euler angles is

$$m\dot{v}_I = \begin{bmatrix} 0 \\ 0 \\ mg \end{bmatrix} + f_{Ic}, \quad f_{Ic} = -T \begin{bmatrix} c_\phi s_\theta c_\psi + s_\phi s_\psi \\ c_\phi s_\theta s_\psi - s_\phi c_\psi \\ c_\theta c_\phi \end{bmatrix} \quad (17)$$

in which f_{Ic} denotes the inertial control force, $T = \sum_{i=1}^4 T_i$ is the total thrust applied by each rotor T_i , $i \in \{1, 2, 3, 4\}$. Ignoring blade flapping effects, the control torques Γ and total thrust T have the following relationship:

$$\begin{bmatrix} \gamma_x \\ \gamma_y \\ \gamma_z \\ T \end{bmatrix} = \begin{bmatrix} 0 & -\delta & 0 & \delta \\ \delta & 0 & -\delta & 0 \\ -K_t & K_t & -K_t & K_t \\ 1 & 1 & 1 & 1 \end{bmatrix} \begin{bmatrix} T_1 \\ T_2 \\ T_3 \\ T_4 \end{bmatrix} \quad (18)$$

in which δ is the distance from the center of gravity for each rotor of the UAV along the x and y body frame axis and K_t captures the relationship between rotor velocity and corresponding torques applied about the z -axis. As long as $\delta K_t \neq 0$, the matrix is invertible and can be used to map a desired thrust command T and control torque command Γ to

a corresponding motor thrust command T_i . Since passivity is not affected by commanding a desired yaw and yaw rate $\psi, \dot{\psi}$ we will allow the user to command a desired yaw while maintaining a desired inertial position (e.g. in order to rotate the view of an on-board camera). Therefore we choose to keep yaw as a free variable to control and use a small-angle assumption to relate attitude to inertial force applied by the rotors.

$$\frac{f_{Ic}}{-T} \approx \begin{bmatrix} 0 \\ 0 \\ 1 \end{bmatrix} + \begin{bmatrix} s_\psi & c_\psi \\ -c_\psi & s_\psi \\ 0 & 0 \end{bmatrix} \begin{bmatrix} \phi \\ \theta \end{bmatrix}. \quad (19)$$

Therefore a desired inertial control command $f_{Ic}^T = [f_{Icx}, f_{Icy}, f_{Icz}]$, will be used to determine a desired inertial set point as follows:

$$\begin{bmatrix} \phi_{\text{set}} \\ \theta_{\text{set}} \end{bmatrix} = \begin{bmatrix} s_\psi & -c_\psi \\ c_\psi & s_\psi \end{bmatrix} \begin{bmatrix} \frac{f_{Icx}}{f_{Icz}} \\ \frac{f_{Icy}}{f_{Icz}} \end{bmatrix}. \quad (20)$$

Finally, there is a non-ideal lag between motor thrust command T_i and the actual thrust applied by each rotor.

$$T_{ai}(s) = \frac{T_i(s)}{\tau s + 1} \quad (21)$$

in which $\tau \approx .1$ seconds represents the thrust lag to each rotor and can not be neglected in designing the controller.

IV. CONTROL IMPLEMENTATION

A. Attitude Control System

Our overall goal is to design a ‘fast’ attitude control system. There are numerous ways to approach this problem, which has been extensively studied throughout the years. Many have taken a Lyapunov (and/or) passivity based approach for controlling attitude [1], [4], [14], [18]–[22]. We will follow the passivity-based approach to control attitude by converting the mapping $H : \Gamma \mapsto \omega$ from a passive system (which we shall recall) to a strictly output passive system which is also inside sector $[0, 1]$. By confining $H : \Gamma \mapsto \omega$ to the $[0, 1]$ sector $H_{sop} : k_\eta e_1 \mapsto \omega$ we can close the loop on attitude using η , which does not consist of a passive mapping $H_\eta \omega \mapsto \eta$. Simulations show that $H_\eta \omega \mapsto \eta$ is confined to the $[-.004, \infty]$ sector for a fairly large range of η and $\dot{\eta}$, which unfortunately is not sufficient to find a gain k_η to satisfy the sector constraints in which $H_\eta = H_2$, and $k_\eta H_{sop} = H_1$ in [7, Corollary 4.3.3] (this is the multiple input-output version of [8, Theorem 2a]). In fact, the weakest ‘combined’ constraints which can be placed on H_1 and H_2 is that H_2 must be strictly input passive and H_1 must essentially be passive. A more interesting case is when H_2 is strictly inside the sector $[0, 1 + \epsilon]$, $\epsilon > 0$ (for example $H_2 = I$ is strictly inside the sector $[0, 1 + \epsilon]$ for all $\epsilon > 0$). When H_2 is strictly inside the sector $[0, 1 + \epsilon]$ for $\epsilon > 0$, then boundedness is guaranteed for any H_1 which is inside the sector $[\frac{-1}{1+\epsilon}, \infty]$.

Theorem 3: Any rigid body with inertia matrix $I = I^T > 0$, $\dot{I} = 0$ and dynamics satisfying the Euler-Lagrange equation (12) (in which $\omega, \Gamma \in \mathbb{R}^3$) is a lossless passive system $H : \Gamma \mapsto \omega$.

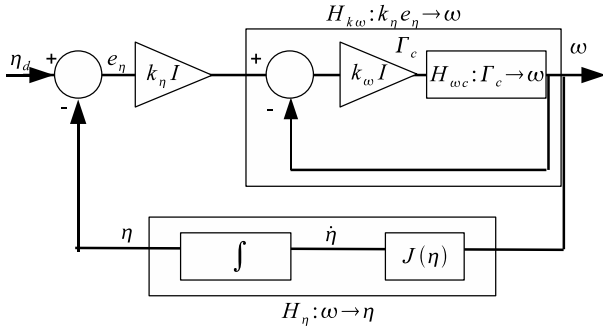

Fig. 4. Proposed attitude control system.

Proof: The total angular energy stored in the UAV is the kinetic energy

$$S(\omega) = \frac{1}{2} \omega^T I \omega > 0, \omega \neq 0$$

The rate change of kinetic energy has the following form

$$\dot{S}(\omega) = \omega^T I \dot{\omega}. \quad (22)$$

We note that $\omega \times$ can be represented as a skew symmetric matrix in terms of $\omega^T = [\omega_1, \omega_2, \omega_3]^T$:

$$\omega \times = \begin{bmatrix} 0 & -\omega_3 & \omega_2 \\ \omega_3 & 0 & -\omega_1 \\ -\omega_2 & \omega_1 & 0 \end{bmatrix}, (\omega \times)^T = -\omega \times$$

Likewise, $C(\omega) = \omega \times I$ is also skew symmetric:

$$C(\omega)^T + C(\omega) = I^T((\omega \times)^T + \omega \times)I = I^T 0 I = 0.$$

Substituting (12) into (22) in terms of $C(\omega)$ results in

$$\begin{aligned} \dot{S}(\omega) &= \omega^T I(-I^{-1}C(\omega)\omega + I^{-1}\Gamma) \\ &= \omega^T C(\omega)\omega + \omega^T \Gamma \\ &= \omega^T \Gamma. \end{aligned}$$

Therefore with $S(\omega) > 0$, $\forall \omega \neq 0$, and $\dot{S}(\omega) = \omega^T \Gamma$, then the UAV angular kinematics describe a lossless passive system $H : \Gamma \mapsto \omega$. ■

Fig. 4 depicts our attitude control system. The following corollary justifies its initial structure.

Corollary 3: The proposed closed-loop attitude control system $H_{cl\omega} : \eta_d \rightarrow \omega$, $k_\eta, k_\omega > 0$ depicted in Fig. 4 is bounded if $H_\eta : \omega \rightarrow \eta$ and $H_{\omega c} : \Gamma_c \rightarrow \omega$ are passive.

Remark 7: Corollary 3 is a direct result of Theorem 1. As previously discussed there are two limitations to the above assumptions. First, the use of Euler angles does not result in a passive mapping for $H_\eta : \omega \rightarrow \eta$. Second, the desired control torques $\Gamma_c \neq \Gamma$ as previously discussed and illustrated in Fig. 5 include a lead compensator in order to recover as much passivity as possible due to the lag in thrust from the motors.

The next corollary justifies the attitude control design, for which we can verify the satisfaction of desired conditions for a large family of desired attitude set points η_d .

Corollary 4: The proposed closed-loop attitude control system $H_{cl\omega} : \eta_d \rightarrow \omega$, $k_\omega > 0$ depicted in Fig. 4 is bounded if the cascaded system $H_{k\omega}H_\eta : k_\eta e_\eta \rightarrow \eta$ are inside the

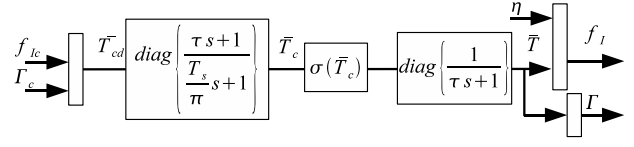

Fig. 5. Relationship between desired inertial control force (f_{Ic}) and control torque Γ_c to actual inertial force f_I and torque Γ .

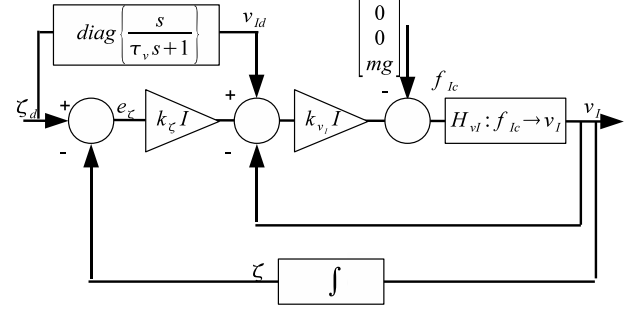

Fig. 6. Proposed inertial control system.

sector $[a, \infty]$ and k_η satisfies the bounds given in Corollary 2 such as when $a_1 < 0$, $0 < k_\eta < -\frac{1}{a}$.

Remark 8: It can be shown that many bounded systems cascaded with an integrator can be bounded by the sector $[a, \infty]$ in which $-\infty < a < 0$. Typically we find that $|a| < 1$ which allows for a reasonable value for k_η . Also, the integrator makes it possible for $\eta = \eta_d$ at steady state.

B. Inertial Control System

In discussing stability for the inertial control system we will denote the system which includes the gravity compensation as $H_{gcomp} : k_{vI} e_{vI} \rightarrow v_I$ in which

$$f_{Ic} = k_{vI} e_{vI} - \begin{bmatrix} 0 \\ 0 \\ mg \end{bmatrix}.$$

It should be obvious for the case when $f_{Ic} = f_I$ that $H_{gcomp} : k_{vI} e_{vI} \rightarrow v_I$ is passive. Which justifies the following corollary.

Corollary 5: The proposed closed-loop inertial control system $H_{cl\zeta} : \zeta_d \rightarrow v_I$, $k_{vI} > 0$ depicted in Fig. 6 is bounded if the gravity-compensated system $H_{gcomp} : k_{vI} e_{vI} \rightarrow v_I$ is passive, since $\int : v_I \rightarrow \zeta$ is passive.

Finally, when $H_{gcomp} : k_{vI} e_{vI} \rightarrow v_I$ is cascaded with an integrator in which

$$\zeta = \int_0^T v_I dt,$$

we denote this cascaded system as $H_{gcomp} \int : k_{vI} e_{vI} \rightarrow \zeta$ and state the following corollary.

Corollary 6: The proposed closed-loop inertial control system $H_{cl\zeta} : \zeta_d \rightarrow v_I$, $k_{vI} > 0$ depicted in Fig. 6 is bounded if the cascaded system $H_{gcomp} \int : k_{vI} e_{vI} \rightarrow \zeta$ are inside the sector $[a, \infty]$ and k_ζ satisfies the bounds given in Corollary 2 such as when $a_1 < 0$, $0 < k_\zeta < -\frac{1}{a}$.

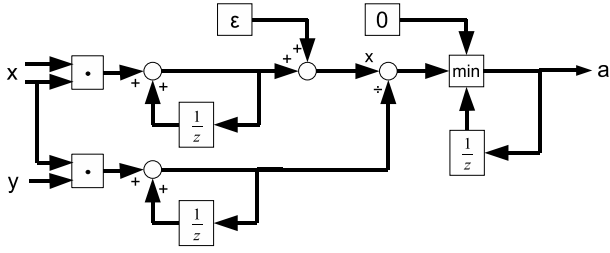

Fig. 7. Simulink block to verify the sector bounds.

V. SIMULATION AND VERIFICATION

A. Verifying Sector Bounds From Simulation

The sector relations from the previously given corollaries allow verification of the sector bounds in a simulation environment. Definition 3 gives the required equation in terms of the input x and output $y = Hx$ and sector limits $[a, b]$.

$$\|y_T\|_2^2 - (a+b)\langle y, x \rangle_T + ab\|x_T\|_2^2 \leq 0$$

To find bounds for a given input signal x and output signal y , consider the following:

$$\begin{aligned} \lim_{b \rightarrow \infty} \left\{ \frac{1}{b} \|y_T\|_2^2 - \frac{a+b}{b} \langle y, x \rangle_T + a \|x_T\|_2^2 \right\} &\leq 0 \\ \Rightarrow -\langle y, x \rangle_T + a \|x_T\|_2^2 &\leq 0 \\ \Rightarrow -\infty < a \leq \frac{\langle y, x \rangle_T}{\varepsilon + \|x_T\|_2^2} \end{aligned} \quad (23)$$

Fig. 7 shows a Simulink implementation of this concept. Running sums are kept for $\|x_T\|_2^2$ and $\langle y, x \rangle_T$ over time. In order to verify a theoretical bound, we must then find inputs which characterize the behavior of the system with respect to parameters that affect those bounds.

The following set of figures illustrates a nominal test flight in which yaw is varied from $-\pi$ to π , furthermore under these flight conditions sector stability is satisfied. In particular $k_\zeta = 1.5$, $k_\eta = 11.5$,

$$H_\zeta : k_\zeta e_\zeta \rightarrow \zeta \text{ is inside } \left[\frac{1}{1.501}, \infty \right] \text{ and}$$

$$H_\eta : k_\eta e_\eta \rightarrow \eta \text{ is inside } \left[\frac{1}{25.78}, \infty \right].$$

Fig. 8 shows the inertial position ζ with respect to time for the test flight. Figures 9, 10, and 11 depict the corresponding tracking error, Euler angles, and control thrust command T_c .

VI. CONCLUSIONS

We have shown a way to design effective control systems for quad-rotor aircraft. These vehicles provide extremely challenging controller design problems; however, breaking the system down into passive components (i.e., treating inertial and attitude control separately) allows us to propose the use of simple yet effective PD controllers. We also showed and verified that yaw can be controlled independently of the desired inertial position. Furthermore, we can use a basic lead compensator to account for non-ideal lag effects

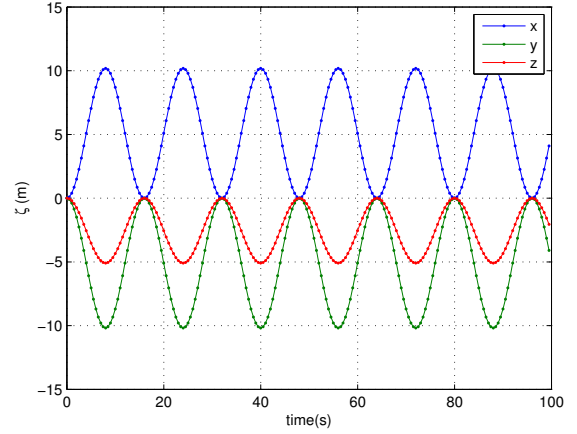

Fig. 8. Test flight which satisfies sector stability.

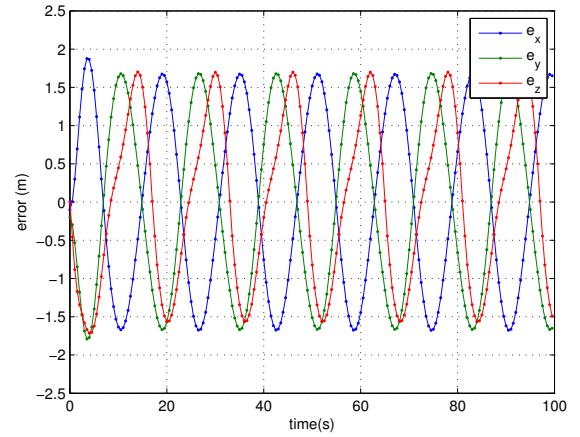

Fig. 9. Corresponding tracking error for test flight.

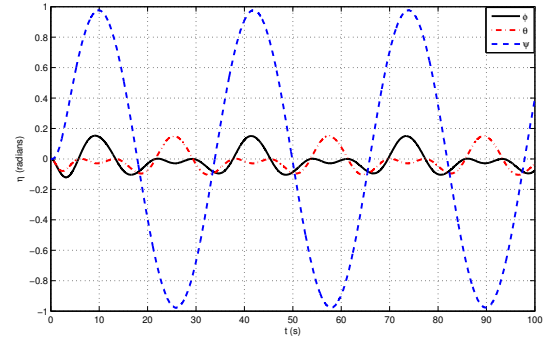

Fig. 10. Corresponding Euler angles for test flight.

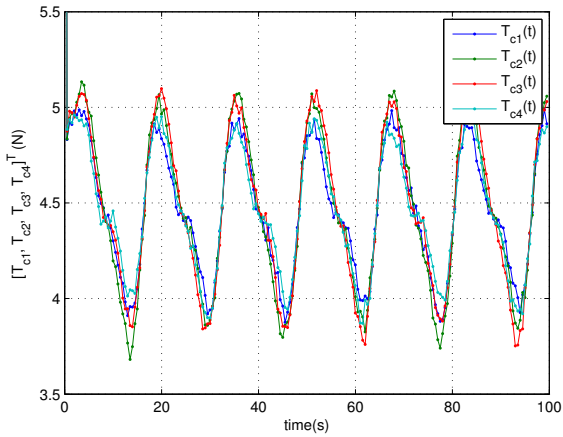

Fig. 11. Corresponding control thrust commands T_c for test flight.

due to thrust. By limiting the command range for pitch and roll we can naturally address actuator saturation issues. System stability can then be verified over a fairly large range of operational conditions by means of Corollary 2. Unfortunately, for higher frequency set-point content k_ζ will not satisfy Corollary 2 – however, the quad-rotor aircraft remains stable in simulation. This emphasizes that Corollary 2 may only be necessary for stability and points towards further investigation of recent mixed passivity and small gain stability results [23], [24].

REFERENCES

- [1] P. Castillo, A. Dzul, and R. Lozano, “Real-time stabilization and tracking of a four-rotor mini rotorcraft,” *Control Systems Technology, IEEE Transactions on*, vol. 12, no. 4, pp. 510–516, 2004.
- [2] A. Teel, “Global stabilization and restricted tracking for multiple integrators with bounded controls,” *Systems & Control Letters*, vol. 18, no. 3, pp. 165–171, 1992.
- [3] —, “A nonlinear small gain theorem for the analysis of control systems with saturation,” *Automatic Control, IEEE Transactions on*, vol. 41, no. 9, pp. 1256–1270, 1996.
- [4] A. Tayebi and S. McGilvray, “Attitude stabilization of a VTOL quadrotor aircraft,” *Control Systems Technology, IEEE Transactions on*, vol. 14, no. 3, pp. 562–571, 2006.
- [5] T. Hamel and R. Mahony, “Image based visual servo control for a class of aerial robotic systems,” *Automatica*, vol. 43, no. 11, pp. 1975–1983, 2007.
- [6] G. M. Hoffmann, H. Huang, S. L. Waslander, and C. J. Tomlin, “Quadrotor helicopter flight dynamics and control: Theory and experiment,” *Collection of Technical Papers - AIAA Guidance, Navigation, and Control Conference 2007*, vol. 2, pp. 1670 – 1689, 2007.
- [7] J. Willems, “The Analysis of Feedback Systems, volume 62 of Research Monographs,” 1971.
- [8] G. Zames, “On the input-output stability of time-varying nonlinear feedback systems. i. conditions derived using concepts of loop gain, conicity and positivity,” *IEEE Transactions on Automatic Control*, vol. AC-11, no. 2, pp. 228 – 238, 1966.
- [9] D. Hill and P. Moylan, “The stability of nonlinear dissipative systems,” *IEEE Transactions on Automatic Control*, vol. AC-21, no. 5, pp. 708 – 711, 1976/10/. [Online]. Available: <http://dx.doi.org/10.1109/TAC.1976.1101352>
- [10] C. A. Desoer and M. Vidyasagar, *Feedback Systems: Input-Output Properties*. Orlando, FL, USA: Academic Press, Inc., 1975.
- [11] A. van der Schaft, *L2-Gain and Passivity in Nonlinear Control*. Secaucus, NJ, USA: Springer-Verlag New York, Inc., 1999.
- [12] N. Kottenstette and P. J. Antsaklis, “Stable digital control networks for continuous passive plants subject to delays and data dropouts,” *2007 46th IEEE Conference on Decision and Control (CDC)*, vol. to appear, pp. 1 – 8, 2007.
- [13] P. Tsiotras, “Further passivity results for the attitude control problem,” *Automatic Control, IEEE Transactions on*, vol. 43, no. 11, pp. 1597–1600, 1998.
- [14] F. Lizarralde and J. Wen, “Attitude control without angular velocity measurement: a passivity approach,” *Automatic Control, IEEE Transactions on*, vol. 41, no. 3, pp. 468–472, 1996.
- [15] J. Diebel, “Representing Attitude: Euler Angles, Unit Quaternions, and Rotation Vectors,” Technical report, Stanford University, California, USA, Tech. Rep., 2006.
- [16] L. Mangiacasale, *Flight Mechanics of a [mu]-airplane: With a Matlab Simulink Helper*. Edizioni Libreria CLUP, 1998.
- [17] C. Johnson, “Positive definite matrices,” *Amer. Math. Monthly*, vol. 77, no. 3, pp. 259–264, 1970.
- [18] B. Wie, H. Weiss, and A. Arapostathis, “Quaternion feedback regulator for spacecraft eigenaxis rotations,” *Journal of Guidance, Control, and Dynamics*, vol. 12, no. 3, pp. 375 – 380, 1989, quaternion Feedback Regulator;Spacecraft Eigenaxis Rotations;Euler’s Eigenaxis Rotation;Quaternion Feedback Stability Analysis;.
- [19] J. Wen and K. Kreutz-Delgado, “The attitude control problem,” *Automatic Control, IEEE Transactions on*, vol. 36, no. 10, pp. 1148–1162, 1991.
- [20] O. Egeland and J. Godhavn, “Passivity-based adaptive attitude control of a rigid spacecraft,” *Automatic Control, IEEE Transactions on*, vol. 39, no. 4, pp. 842–846, 1994.
- [21] O. Fjellstad and T. Fossen, “Position and attitude tracking of AUV’s: a quaternion feedback approach,” *Oceanic Engineering, IEEE Journal of*, vol. 19, no. 4, pp. 512–518, 1994.
- [22] B. Costic, D. Dawson, M. De Queiroz, and V. Kapila, “Quaternion-based adaptive attitude tracking controller without velocity measurements,” *Journal of Guidance, Control, and Dynamics*, vol. 24, no. 6, pp. 1214–1222, 2000.
- [23] W. Griggs, B. Anderson, and A. Lanzon, “A mixed small gain and passivity theorem in the frequency domain,” *Systems & Control Letters*, vol. 56, no. 9-10, pp. 596–602, 2007.
- [24] W. Griggs, B. Anderson, A. Lanzon, and R. M.C., “Interconnections of nonlinear systems with “mixed” small gain and passivity properties and associated input-output stability results,” *Systems & Control Letters*, vol. to appear, pp. 1–17, 2009.