

Dimensional Accuracy and Surface Finish Optimization of Fused Deposition Modelling Parts using Desirability Function Analysis

Stephen O. Akande

School of Mechanical and System Engineering
Newcastle University
Newcastle, UK

Abstract— Fused deposition modelling (FDM) machines are increasingly being used to manufacture parts for functional use. The need to ensure that the parts have good surface finish and dimensional accuracy thus exist. The work described in this paper aim to determine the optimum process parameters that can be used to produce parts with both good surface finish and dimensional accuracy. Test parts were fabricated on FDM machine with different factor levels of layer thickness, speed of deposition and fill density. Factorial design of experiment (DOE) and desirability function were used to investigate the optimum factor levels for fabricating parts. The optimum factor levels for dimensional accuracy was observed to be different from that of surface roughness. Optimum process factors levels for minimization of both surface roughness and dimensional accuracy were then determined in this research work. The experimental results was validated by producing parts with the obtained optimum process parameters.

Keywords— Fused filament fabrication, desirability function, Polylactic acid, dimensional accuracy, surface roughness

I. INTRODUCTION

Rapid product development is very crucial for organization to have competitive advantage over its competitors. Increasing market globalization and reduction in product development cycle is a necessity for survival in industrial economies [1]. High quality products that are introduced into the market before those of their competitors enjoy more patronage and are more profitable. As a result of these advantages great efforts are put into bringing high quality product into the market quickly. A technology which considerably speeds up the product development cycle is the concept and practice of rapid prototyping (RP)/ additive manufacturing (AM). Fused deposition modelling (FDM) is one of the most important AM processes because of ease of operation, low cost of machinery of part made by the process, durability of product and easy material changeability [2, 3]. An FDM machine (Figure 1) consists of an extruder head with nozzle for depositing heated filaments, some machines have a single nozzle while others have multiple nozzles. One of the nozzle is used for depositing part material and the other for depositing support material. The tool path of the extruder head is based on computer numerical control system which enables material to be deposited in precise pattern and on the platform and also controls movement of the platform. The

process involves the movement of filaments from the filament reels through a system of rollers into the extruder head where it is heated to semi – liquid (molten state) and then deposited on the movable platform. The deposited material is called “road” which then cools and solidifies. On completion of deposition of a layer the movable platform will move downward (Z – direction) and another layer will then be deposited or bonded on the previous layer. This process continues until the part is fully built.

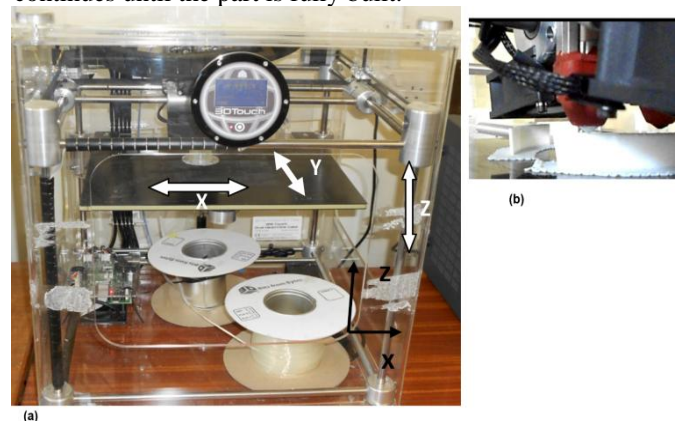

Figure 1 (a) 3D Touch FFF machine (b) extruder head depositing material

However, improvement is still required for FDM to move from rapid prototyping to manufacturing of functional parts. The need for parts to have good mechanical properties during service conditions and the need for dimensional accuracy to be controlled and better surface finish [4, 5] has been identified. McClurkin [6] and Kruth et al. [7] pointed out that dimensional accuracy of parts made using rapid prototyping system is very important for it to be used as a primary manufacturing process. The quality of FDM fabricated part is also dependent on the processing conditions[8]. There is thus need of studying the effect of processing parameters on the quality of fabricated part with the aim of optimising the parameters in order to produce part with good surface finish and dimensional accuracy. Due to capability of FDM to be used for manufacturing of functional parts, some work has been done on improving the quality of part made by FDM process.

Pennington et al. [9] investigated effect of the position of parts in the building envelope, part size and envelope temperature on dimensional accuracy of parts made by FDM using ABS material. And it was reported that the studied factors have significant effect on dimensional accuracy. Surface finish and dimensional accuracy are very important either for aesthetic purpose or for mating and functional parts in service condition. Surface roughness of parts is also affected by the speed of deposition, layer thickness and road width [10]. Vasudevarao et al. [11] also pointed out surface roughness of parts made by using FDM machine to be significantly affected by layer thickness and part orientation. Wang et al.[12] used Taguchi method with the Gray relational analysis to optimise dimensional accuracy and ultimate tensile strength of FDM ABS made part. Martínez et al.[13] also uses Taguchi methodology and ANOVA analysis to select the best process parameters for surface finish of FDM made part.

However, it can be observed from literature that most of the previous work in FDM either focused on optimization of a single response or limited to ABS material unlike this research work. Also, the significance of factors for optimisation of a single response does not necessarily mean they can be significant for optimisation of multiple responses [14]. There is thus need for multiple response optimisation of quality characteristics of dimensional accuracy and surface finish.

Desirability function analysis had been used successfully in optimization of multiple objectives. Ramanujam et al. [15] used desirability function analysis for optimization of multiple machining process parameters for turning of Al-15%SiC_p composites. Anoop et al. [16] also used it for optimizing process parameters for maximizing tensile strength, flexural strength and impact strength of fused deposition modelling parts.

This research aim at optimization of multiple objectives of dimensional accuracy (and surface roughness of FDM made parts using desirability fuction. This paper will thus combine full factorial experimental design with desirability function analysis to evaluate the effect of process parameters on quality characteristics and determine optimum parameter settings for fabrication of part in FDM. This research will thus be useful in fabrication of part with good quality characteristics that are understudied in this research.

II. EXPERIMENTAL PLAN

The FDM system from Bits from Bytes that is owned by 3D Systems is a low cost rapid prototyping system. 3D Touch printer (Figure 1) from the company was used for this experiment and it uses Axon software for setting the process parameters (factors). The part design was firstly created in Autodesk Inventor and then converted to STL file format before being imported into the Axon software for setting of processing parameters and conversion of the STL file to a BFB print file that defines the tool path for printing of the parts.

However, it was observed in literature that surface finish and dimensional accuracy are affected by layer thickness and speed of deposition, they are thus considered in these experiments, in addition to fill density that was not considered in previous studies by various authors each at two levels as shown in Table 1. The available process parameters that were used in these experiments are thus described as:

- Layer thickness: It is thickness of deposited filament layer
- Fill density: The building of a part begins with deposition of molten filament called 'road' and collection of roads form the layer. The deposited road is used for defining the perimeter of the part to form a close boundary which will later be fill using a fill pattern. The density of filling process is called fill density and the fill style is called fill pattern.
- Print speed: Is the linear speed of movement of the nozzle in the XY plane. In the BFB machine a "speed multiplier" is used for increasing the speed of deposition. The speed multipliers of 1X and 1.3X are approximately equivalent 16 mm/s and 21.33 mm/s respectively.

The FDM machine build specification showing the low and high factors levels settings that were used in these experiments is shown in Table 1.

Table 1 Experimental plan: Process factors settings

Factors	Low level (-1)	High level (1)
Layer thickness	0.25mm	0.5mm
Speed multiplier	1X	1.3 X
Fill density	20%	100%

A. Experimental procedures

Test specimens were made using PLA material source from Bits from Bytes and built on 3D –touch printer. The processing factors are as shown in Table 1.

1) Experimental design

Design of experiments (DOE) and Taguchi method have been used for optimization of process parameters in various fields [10, 17-24]. Factorial design of DOE with two –levels for each factor have been reported to be efficient in factors screening or process characterization [25]. It is therefore adopted in this experiment. The experiment plan consist of 16 runs, four blocks, two replicates and was randomized. Minitab 16.0 was used to generate the design matrix for the DOE with each run corresponding to the various factor levels combination that will produce the responses for quality characteristics of dimensional accuracy and surface finish that are examined in this study.

2) Test specimens

The design of specimens used for evaluating the dimensional accuracy and surface finish is as shown in Figure 2.

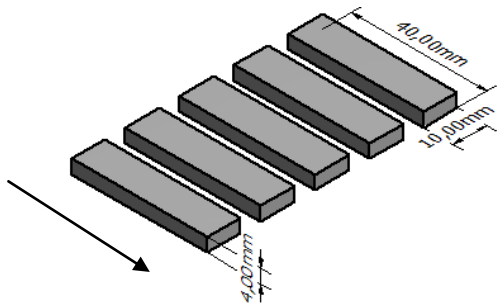

Figure 2 Specimens for dimensional accuracy and surface roughness with dimensions

B. Dimensional measurement

Dimensions of the fabricated set of specimens were measured using a Mitutoyo Digital Calliper with a resolution of 0.01mm and then compared with the CAD design to find out the dimensional accuracy of the process with respect to length, width and thickness per sample. Deviation is the difference between the nominal dimensions from that of the measured dimensions.

C. Surface roughness measurement

Surface roughness of fabricated part (Figure 2) were measured using Taylor – Hobson (Talysurf) surface texture measuring instrument and in accordance to BS ISO 4287:1997. It involve movement of Talysurf stylus tip across the top surface of specimen in order to acquires deviations in surface profile or to measured roughness of the surface in measurement direction shown in Figure 2. Roughness of the surface (R_a) is obtained from the machine output result and is the arithmetic average of the departures of the roughness profile from the centerline within the evaluation length [26].

$$R_a = \frac{1}{l} \int_0^l |y(x)| dx \quad (2)$$

Where, R_a is the mean roughness of the evaluated surface profile, $y(x)$ is the height of the surface profile, and l is the sampling length

III. EXPERIMENTAL ANALYSIS

1) Pareto chart analysis

Pareto chart is used in DOE for comparison of relative size of effects and evaluating their statistical significant. The chart display in Minitab consist of absolute value of effects with a reference line which corresponds to $\alpha = 0.05$ drawn on the chart for evaluating the significance of factors effects. An effect that crosses the reference line is statistically significant.

2) Desirability function analysis (DFA)

One method of optimizing multiple responses simultaneously is the use of desirability function as demonstrated by Derringer and Suich [27]. The methodology involves the use of desirability function, while the factors level with highest desirability is the optimal factors settings for the response. Desirability is calculated by using Eq. (4) to (5) [28]: The individual desirability function is given by Eq. (4)

$$d_i = f_i(y)^{W_i} \quad (4)$$

Where: W_i is the weight for response i , and the function $f_i(y)$ is dependent on optimization objective which may be to hit a target, minimize or maximize response. y is the response value. Since the goal of this experimentation is minimization of responses, then $f_i(y)$ is given as:

$$f_i(y) = \begin{cases} 1 & y < T \\ \left(\frac{U-y}{U-T}\right) & T \leq y \leq U \\ 0 & y > U \end{cases} \quad (5)$$

Where, U represent the upper acceptable response value and T is the target value.

Composite desirability (D) is calculated as follows:

$$D = (d_1^{I_1} * d_2^{I_2} * \dots * d_n^{I_n})^{1/(I_1+I_2+\dots+I_n)} \quad (6)$$

d_i is the individual desirability for response i , and I_i is the importance for response i ($i = 1, 2, \dots, n$)

For the same importance for each response, the overall desirability is given as the geometric mean of the individual desirability (d_1, d_2, \dots, d_n):

$$D = (d_1 * d_2 * \dots * d_n)^{1/n} \quad (7)$$

The composite desirability for both weights and importance is given by Eq. (8) and is obtained by substituting Eq. (4) into Eq. (6)

$$D = (f_1(y)^{W_1 I_1} * f_2(y)^{W_2 I_2} * \dots * f_n(y)^{W_n I_n})^{1/(I_1+I_2+\dots+I_n)} \quad (8)$$

3) Optimization

In order to determine optimal factor level settings, for minimization of variations in length, width, thickness and surface roughness, desirability function analysis (DFA) was used. The individual desirability (d) is normally used for evaluating the extent to which factor settings optimize a single response while composite desirability (D) evaluates the extent to which factor settings optimize a group of responses generally [29]. Desirability value varies between 0 and 1. One represents an ideal situation while zero means that one or more of the responses are not within the desired acceptable limits. Weight is used for defining the shape of desirability function for each response. It is used for emphasizing or de-emphasizing the target. A weight that is less than one will place less importance on the target and a weight of one places emphasis on target and bound. If all the responses are equally important a default value of 1 is to be used. Since all the responses, target and bound are equally important to obtain a realistic optimal value. Weight and importance of one were chosen for each response in this analysis. The goal of this experiment is to minimize response, thus the optimal setting will be obtained by maximizing the composite desirability (the higher the better) [15, 30].

IV. EXPERIMENTAL RESULTS

Five specimens (see Figure 2) were made for each experimental run and the mean of the responses is taken as the representation of the values of dimensions and surface roughness (R_a) for each of the 16 experimental runs as shown

in Table 2. Each run has a combination of factor levels which will be used for evaluating the significance of factors on the respective responses. Where, La, SD and FD in the table

represent layer thickness, speed of deposition and fill density respectfully.

Table 2 Experimental design matrix and data of respective responses for each run

Run Order	Blocks	La	SD	FD	% Δ length	% Δ width	% Δ thickness	Ra (μm)
1	4	-1	-1	1	0.81	4.08	10.40	3.72
2	4	-1	1	-1	0.69	3.02	7.50	2.46
3	4	1	1	1	0.24	0.78	8.95	13.42
4	4	1	-1	-1	0.16	0.22	5.90	17.52
5	3	-1	1	1	1.13	5.70	14.80	13.18
6	3	1	1	-1	0.16	0.32	7.45	11.98
7	3	1	-1	1	0.12	0.56	5.85	16.82
8	3	-1	-1	-1	0.39	1.72	5.15	2.12
9	1	1	1	-1	0.15	0.56	6.75	16.02
10	1	1	-1	1	0.03	0.76	6.90	19.34
11	1	-1	1	1	1.21	5.86	13.65	17.24
12	1	-1	-1	-1	0.59	1.94	8.70	2.12
13	2	1	-1	-1	0.11	0.86	8.40	22.48
14	2	1	1	1	0.17	0.40	6.90	13.62
15	2	-1	-1	1	0.96	3.84	11.45	5.84
16	2	-1	1	-1	0.69	2.56	4.45	1.86

A. Dimensional accuracy and surface roughness

Figure 3 shows Pareto charts of the effects for percentage change in thickness, width, length and surface roughness at 95% confidence level ($\alpha = 0.05$).

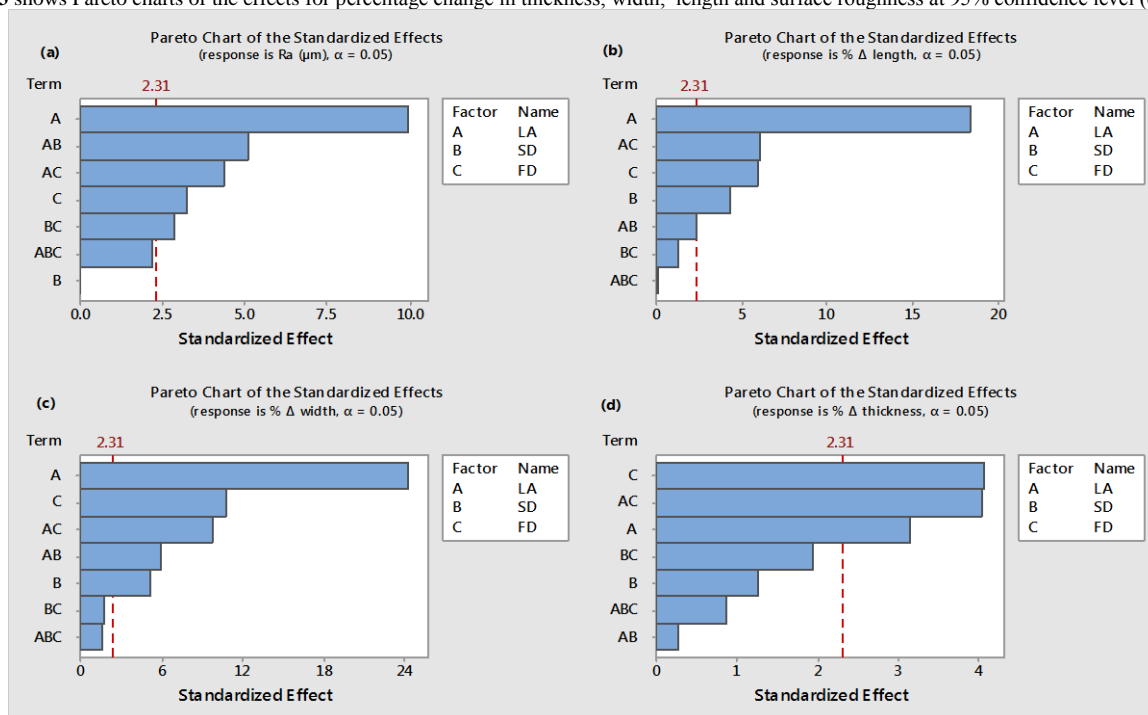

Figure 3 Pareto chart of standardized effects for (a) Surface roughness (b) % change in length (c) % change in width (d) % change in thickness

B. Response Optimization

Table 3 and Table 4 show the goal of the optimization which in this case is minimization, the specified response target and upper bounds, weight and importance values and optimal parameter levels and composite desirability values.

Table 3 Optimal factor levels for individual dimensional accuracies and surface roughness

	Goal	Target	Parameters			Global solution (coded units)	d_i
			Upper	Weight	importance		
% Δ L	Minimum	0.03	1.21	1	1	LA =1, SD = -1, FD = -1	0.897
% Δ W	Minimum	0.22	5.86	1	1	LA =1, SD = -1, FD = -1	
% Δ T	Minimum	4.45	14.80	1	1	LA =1, SD = -1, FD = -1	
Ra (μ m)	Minimum	1.86	22.48	1	1	LA = -1, SD = -1, FD = -1	0.987

Table 4 Optimal factor levels for combine response (dimensional accuracies and surface roughness)

	Parameters						d_i
	Goal	Target	Upper	Weight	importance	Global solution (coded units)	
% Δ L	Minimum	0.03	1.21	1	1	LA =-1, SD = -1, FD = 1	0.927
% Δ W	Minimum	0.22	5.86	1	1	LA =-1, SD = -1, FD = 1	
% Δ T	Minimum	4.45	14.80	1	1	LA =-1, SD = -1, FD = 1	
Ra (μ m)	Minimum	1.86	22.48	1	1	LA = -1, SD = -1, FD = 1	

Ten specimens was also produced for the confirmation experiments based on the obtained optimal solutions from the analysis of data obtained in the experimental runs. The dimensional accuracy and surface roughness from experimental runs based on optimization settings in Table 4 is shown Figure 4. Where Δ L is change in length, Δ W is change in width, Δ T is change in thickness.

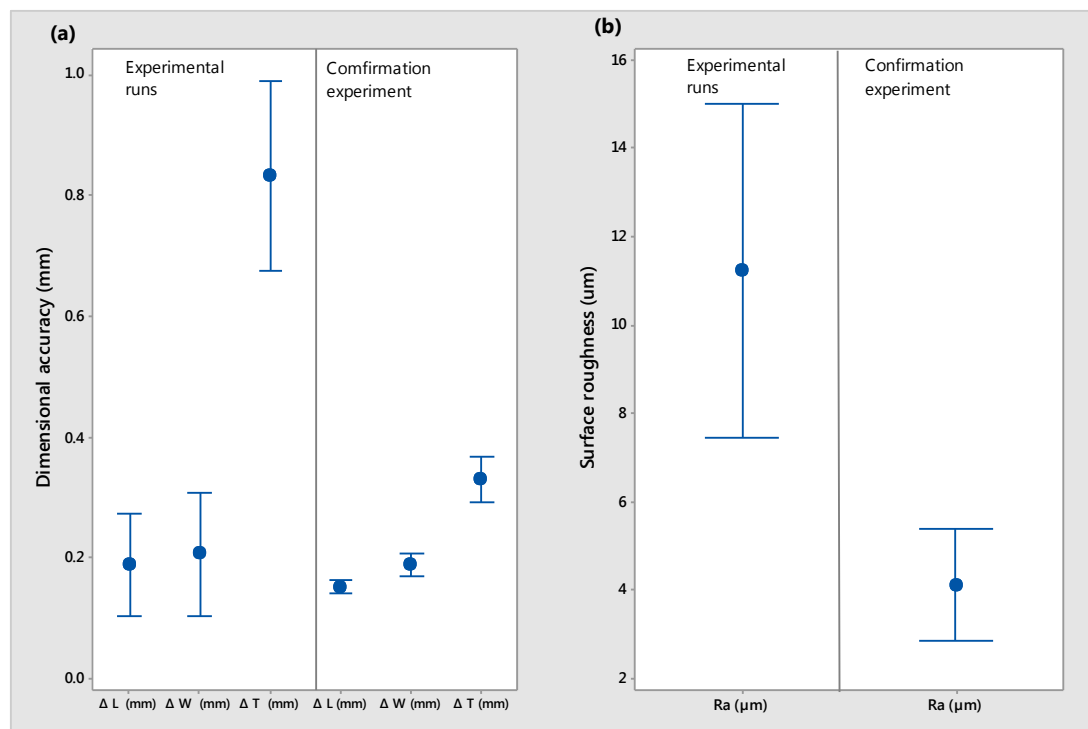

Figure 4 Confirmation experiments for (a) Dimensional accuracy (b) Surface roughness, error bars indicate 95% confidence interval

V. DISCUSSIONS

A. Variation of dimensional accuracy and surface roughness with parameter sets

From

Figure 3 the most significant factor affecting dimensional accuracy and surface roughness is layers thickness. All the factor effects that crosses the reference line (2.31) are statistically significant. The order of the significant effects of the evaluated parameters is also as shown in that figure. This results also suggest that the level of significance for each evaluated response vary from each other. Speed of deposition have not effect on the surface roughness and percentage change in thickness but interaction between speed of deposition and fill density is significant for surface roughness.

B. Optimal process parameters

From Table 3 the optimal parameter sets for dimensional accuracy are high layer thickness, low speed of deposition and low fill density while that for surface roughness are low layer thickness, low speed of deposition and low fill density. Because of the mismatch between the required optimum process parameter sets for both dimensional accuracy and surface roughness a need to determine a combine optimum parameter sets for both properties thus exist. Optimization was then carried out to find the optimum global solution for both dimensional accuracy and surface roughness (see Table 4). The obtained combine desirability function value is 0.927 thus the optimal solution is satisfactory since it is very close to highest possible value of 1. Reduction in dimensional inaccuracy and surface roughness (see Figure 4) can be observed when the optimum process parameters that was obtained from the analysis of experimental results was used to fabricate test parts. The experimental results is thus validated.

VI. CONCLUSION

The effect of process parameters of speed of deposition, layer thickness and fill density on dimensional accuracy and surface roughness of FDM made parts have been evaluated. The process parameters were observed to affect those properties differently. Desirability function was then used to determine the optimum process parameters for the minimization of both dimensional inaccuracy and surface roughness. The experimental results was validated by producing parts with the obtained optimum process parameters. Experimental results tend to suggest that it is possible to produced parts with both optimum surface roughness and dimensional accuracy.

VII. REFERENCES

- Gunasekaran, A., *Agile manufacturing: enablers and an implementation framework*. International Journal of Production Research, 1998. **36**(5): p. 1223-1247.
- Levy, G.N., R. Schindel, and J.P. Kruth, *Rapid manufacturing and rapid tooling with layer manufacturing (LM) technologies, state of the art and future perspectives*. CIRP Annals - Manufacturing Technology, 2003. **52**(2): p. 589-609.
- Rosochowski, A. and A. Matuszak, *Rapid tooling - the state of art*. Journal of Materials Processing Technology, 2000. **106**: p. 191 - 198.
- Sun, Q., et al., *Effect of processing conditions on the bonding quality of FDM polymer filaments*. Rapid Prototyping Journal, 2008. **14**(2): p. 72-80.
- Gregorian, A., et al. *Accuracy improvement in rapid prototyping machine (FDM-1650)*. in *Solid Freeform Fabrication Proceedings*. 2001.
- McClurkin, J.E. and D.W. Rosen, *Computer-aided build style decision support for stereolithography*. Rapid Prototyping Journal, 1998. **4**(1): p. 4-13.
- Kruth, J.P., M.C. Leu, and T. Nakagawa, *Progress in Additive Manufacturing and Rapid Prototyping*. CIRP Annals - Manufacturing Technology, 1998. **47**(2): p. 525-540.
- Zhou, J.G., D. Herscovici, and C.C. Chen, *Parametric process optimization to improve the accuracy of rapid prototyped stereolithography parts*. International Journal of Machine Tools and Manufacture, 2000. **40**(3): p. 363-379.
- Pennington, R.C., N.L. Hoekstra, and J.L. Newcomer, *Significant factors in the dimensional accuracy of fused deposition modelling*. Proceedings of the Institution of Mechanical Engineers, Part E: Journal of Process Mechanical Engineering, 2005. **219**(1): p. 89-92.
- Anitha, R., S. Arunachalam, and P. Radhakrishnan, *Critical parameters influencing the quality of prototypes in fused deposition modelling*. Journal of Materials Processing Technology, 2001. **118**(1-3): p. 385-388.
- Vasudevarao, B., et al. *Sensitivity of RP surface finish to process parameter variation*. in *Solid Freeform Fabrication Proceedings*. 2000.
- Wang, C.C., T.W. Lin, and S.S. Hu, *Optimizing the rapid prototyping process by integrating the Taguchi method with the Gray relational analysis*. Rapid prototyping journal, 2007. **13**(5): p. 304-315.
- Martínez, J., et al. *Modelization of surface roughness in FDM parts*. in *AIP Conference Proceedings*. 2012.
- Antony, J., *Simultaneous optimisation of multiple quality characteristics in manufacturing processes using Taguchi's quality loss function*. The International Journal of Advanced Manufacturing Technology, 2001. **17**(2): p. 134-138.
- Singh, H. and P. Kumar, *Optimizing multi-machining characteristics through Taguchi's approach and utility concept*. Journal of Manufacturing Technology Management, 2006. **17**(2): p. 255-274.
- Sood, A.K., R.K. Ohdar, and S.S. Mahapatra, *Parametric appraisal of mechanical property of fused deposition modelling processed parts*. Materials & Design, 2010. **31**(1): p. 287-295.
- Liao, H.T. and J.R. Shie, *Optimization on selective laser sintering of metallic powder via design of experiments method*. Rapid prototyping journal, 2007. **13**(3): p. 156-162.
- Zalba, B., B. Sánchez-valverde, and J.M. Marín, *An experimental study of thermal energy storage with phase change materials by design of experiments*. Journal of Applied Statistics, 2005. **32**(4): p. 321-332.
- Sun, A.Y.T., S. Anand, and J.S.Y. Tang, *Comprehensive design of experiments-based framework for optimal CMM inspection and uncertainty analysis of form tolerances*. International Journal of Production Research, 2002. **40**(9): p. 2097-2123.
- Lin, T. and B. Chananda, *Quality Improvement of an Injection-Molded Product Using Design of Experiments: A Case Study*. Quality Engineering, 2003. **16**(1): p. 99-104.
- Lee, B.H., J. Abdullah, and Z.A. Khan, *Optimization of rapid prototyping parameters for production of flexible ABS object*. Journal of Materials Processing Technology, 2005. **169**(1): p. 54-61.
- Sreenathbabu, A., K.P. Karunakaran, and C. Amarnath, *Statistical process design for hybrid adaptive layer manufacturing*. Rapid prototyping journal, 2005. **11**(4): p. 235-248.

23. Bisgaard, S., *Process Optimization: Going Beyond Taguchi Methods*. 1991: Center for Quality and Productivity Improvement, University of Wisconsin-Madison.
24. Montgomery, D.C., *Design and analysis of experiments*. 4th ed. 1997, New York: Wiley. xiii, 704.
25. Montgomery, D.C., *Design and analysis of experiments*. 6th ed. 2005, Chichester: Wiley. xv, 643.
26. BSI 6741: Part 1 : 1987, *Surface roughness terms*. 1987, BSI Standards Publication, London.
27. Derringer, G. and R. Suich, *Simultaneous optimization of several response variables*. J. Quality Technol., 1980. **12**: p. 214-219.
28. Minitab Inc. *How Minitab calculates the desirability values when using the Response Optimizer?* 2012 [cited 2012 10th October]; Available from: <http://www.minitab.com/en-GB/support/answers/answer.aspx?ID=1342&langType=2057>.
29. Minitab Inc. *Response optimization*. Minitab 16.0 Software Help: Design of experiments tutorial, 2012.
30. Ramanujam, R., R. Raju, and N. Muthukrishnan, *Taguchi Multi-machining Characteristics Optimization in Turning of Al-15% SiCp Composites using Desirability Function Analysis*. Journal of studies on manufacturing, 2010. **1**: p. 120-125.