

## Dimensioning of optical multicast for dynamic WDM convergent access networks

### *Dimensionado de multicast óptico para redes WDM de acceso dinámicas convergentes*

Gustavo Puerto Leguizamón<sup>1</sup>    Miguel Sastoque Caro<sup>1</sup>    Carlos Suárez Fajardo<sup>1</sup>

Recibido 19 de mayo de 2014, aceptado 6 de agosto de 2014

*Received: May 19, 2014    Accepted: August 6, 2014*

#### ABSTRACT

This paper presents a teletraffic study that evaluates the benefits of a passive optical access network, fix/mobile, by multiplexing wavelength division (WDM-PON) in which it is appreciated the impact of including extra wavelengths channels for the transmission of multicast services versus the multicast transport service using replicated unicast connections. The conclusion is that under heavy bulk-data traffic, the nominal data rate and tolerated efficiency are defined by the maximum number of out-of-profile users permitted for every multicast solution. Specifically, for the high values of efficiency the channels of extra wavelength avoid the need of multicast wavelengths used only when there is a fraction (significantly small) of out-of-profile users (5%).

Keywords: Dynamic wavelength allocation, multicast networks, optical access networks, passive optical networks.

#### RESUMEN

*Este artículo presenta un estudio de teletráfico que evalúa las prestaciones de una red óptica de acceso pasiva, convergente fija/móvil, por multiplexación en división de longitud de onda (WDM-PON) en la cual se valora el impacto de incluir canales de longitudes de onda extra para la transmisión de servicios multicast contra la solución al transporte de servicios multicast usando conexiones unicast replicadas. Se concluye que bajo condiciones de alta carga de tráfico, la tasa de datos nominal y la eficiencia tolerada definen el máximo número de usuarios fuera de perfil soportados para cada solución multicast considerada. Específicamente, para valores altos de eficiencia, los canales de longitud de onda extra evitan la necesidad de longitudes de onda multicast dedicadas solamente cuando se tiene una fracción de usuarios fuera de perfil sustancialmente pequeña, alrededor de un 5%.*

*Palabras clave: Asignación dinámica de canales, redes multicast, redes ópticas de acceso, redes ópticas pasivas.*

#### INTRODUCTION

Passive Optical Network (PON) is becoming a popular choice for broadband access. In the downstream, PON relies on concurrent Time

Division Multiplexing (TDM) connections between the Optical Line Terminal (OLT) and the Optical Network Unit (ONU) to distribute a bandwidth of up to 2.5 Gb/s among up to 128 subscribers [1]. However, the large growth of Internet traffic and

<sup>1</sup> Universidad Distrital Francisco José de Caldas. Facultad de Ingeniería. Carrera 7 N° 40B-53. Bogotá, Colombia.  
E-mail: gapuerto@udistrital.edu.co; masastoquec@correo.udistrital.edu.co; csuarezf@udistrital.edu.co

video based applications will put into evidence the shortage of the access network capacity, with expected future services based on highly-bandwidth-consuming video applications as shown in a recent Cisco forecast traffic [2].

Based on that forecast, it is clear that video services will dominate the bandwidth consumption in the forthcoming years. In this context, two important aspects have to be evaluated; the first one is related to the access network, which capacity must satisfy the ever-increasing bandwidth demand. The second aspect deals with the services distribution in the access segment itself. Today, multicast services have become very popular as telecommunications operators take advantage of multicasting solutions to distribute contents to a large number of users. Multicast is an important functionality for Triple Play Services where voice communication, video services and broadband Internet have to be efficiently distributed in the access network among a wide number of users.

On the other hand, Radio Access Network (RAN) environments supporting multimedia applications, as those featured by recent 4G mobile networks, present new challenges for multicast service distribution protocols. As users move inside the RAN, the routing protocol has to guarantee the reachability of network services during all of the possible handover processes, especially in the case of active communications. Nowadays these networks distribute multicast services using point-to-point unicast transmission; this strategy results in redundancy and increment of network resource utilization. In addition, most of the existing multicast routing protocols are IP-based controlled by the Internet Group Management Protocol (IGMP) [3-4], which deals with the creation and management of multicast group membership and by definition excludes Quality of Service (QoS) considerations or the creation of a single optimal multicast distribution tree [5]. In the RAN segment those approaches are today far too restricted today and lead to potential inconsistencies in the functionality and capability throughout the access infrastructure due to the non-ubiquity of the IP multicasting.

In this context, the WDM-PON paradigm [6-7] arises as the most promising access network technology to support the increasing bandwidth consumption while enables advanced features in the physical

layer such as optical multicast and dynamic channel allocation. Recently several architectures have been proposed for WDM-PON multicast services distribution, the approaches aim at increasing the performance and capabilities in terms of security, amount of end-users on line, flexibility and reliability, all of this according to an increment of broadcast in multicast multimedia services. As far as the architecture is concerned, different schemes at the physical layer have been proposed to achieve benefits in specific applications, for instance, simultaneity in downstream and upstream flows with unicast and multicast connections according with the switching scheme [8-9]. Another approach of WDM-PON multicast is proposed [10] where WDM is mixed with frequency reuse to increase the capacity in the physical layer, the results of this scheme present an amount of 32 end-fixed-users with 10 Gb/s unicast downlink and 2.5 Gb/s unicast uplink. Finally, an architecture that provides a survivable operation with a Bit Error Rate (BER) close to  $1 \times 10^{-9}$  while offering high network availability and reliability described in [11-12]. To the best of our knowledge, there have not been proposals for dynamic convergent optical multicast besides one of our previous works [13] and none of the related works deal with a study that evaluates the data traffic conditions that make the replicated-unicast solution no longer feasible as compared to dedicated multicast wavelength channels for the delivery of multicast services.

In this work the WDM-PON access network platform described in [13], which supports several multicast-related functions at the physical layer for converged fixed and mobile users, is evaluated. A performance assessment work to establish under which conditions multicast based on replicated-unicast connections is no longer beneficial, in comparison to dedicated multicast wavelengths, is presented. For that reason, threshold values between the two alternatives are determined, such thresholds are given in terms of the relative proportion of users behaving according to two possible types of Internet traffic profiles: web browsing and High Definition (HD) video streaming.

## MATERIALS AND METHODS

Current PON systems transmit on one data wavelength from the OLT to the ONU as depicted in Figure 1. The data carried by a given wavelength

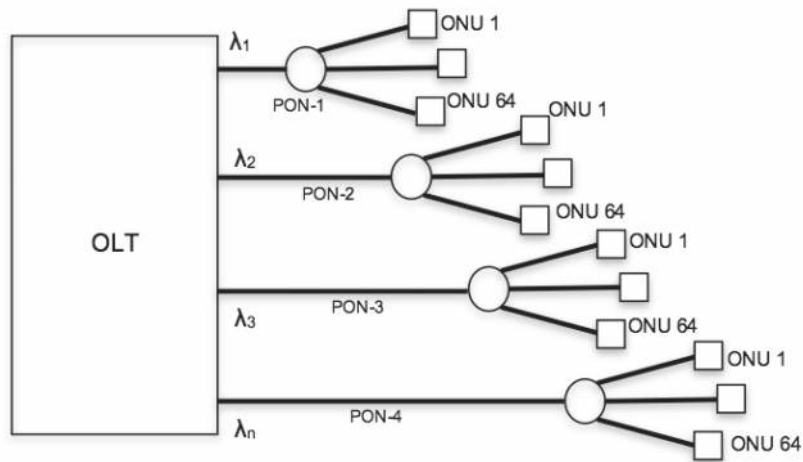

Figure 1. Standard PON network model featuring single-static wavelength distribution. Source: Authors.

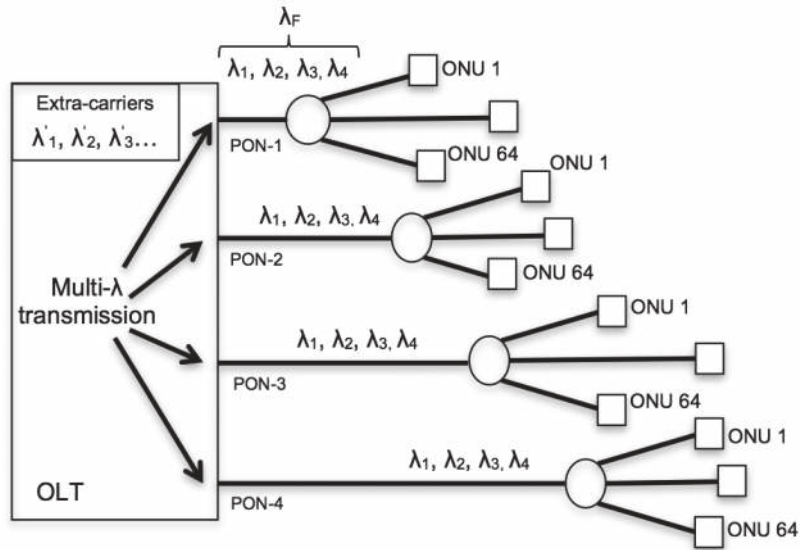

Figure 2. Approach for WDM-PON network model featuring multiple-dynamic wavelength distribution. Source: Authors.

is evenly distributed among the ONUs within each PON, where a static wavelength allocation is performed. Evolved PON networks will include multiple wavelength distribution in order to increase capacity in the system as seen in Figure 2. This paradigm is known as WDM-PON.

In this context, each ONU is multi-wavelength-processing-capable with static or dynamic wavelength allocation depending on whether a tunable or fixed filter is used for optical channel selection at the

ONU [14]. It should be pointed out that upgrading the OLT to enable multi-wavelength allocation implies the use of one fixed transmitter per additional wavelength at the OLT. Tunable transmitters can also be used; however it results in a complex downstream distribution in terms of data control plane due to the TDM-like behavior of the optical bursts generated by the tunable transmitter.

The studied scenario follows the setup shown in Figure 2; four fixed wavelengths carry the multicast

data (Multicast-1 and Multicast-2) by means of TDM replicated-unicast connections on each fixed wavelength  $\lambda_F = (\lambda_1 - \lambda_4)$ . Though additional wavelengths might be used, this implies the use of more transmitters with their associated cost. The available capacity of each fixed wavelength is assumed to be 10 Gb/s; while a multicast data accounts for 2.52 Gb/s, the remaining 7.48 Gb/s are available for the delivery of Internet traffic. Each ONU serves 64 users (i.e.: the system comprises 256 users in total). From the downlink perspective, the Internet access service makes bulk-data download possible for each user. Note that the OLT assigns the available capacity of each fixed wavelength to Internet traffic, and enforces solutions for the equitable sharing of capacity among all users downloading data. As a converged network is considered, that is, an optical network able to transport wireless data, it should be pointed out that the Internet traffic and multicast data can be requested by both fixed and mobiles users. To ascertain if the bit rate share is below an acceptable level, two parameters are defined: the nominal bit rate  $N$  and the link efficiency parameter  $e$ . The lower bound  $B$  for the bit rate is then defined as:

$$B = eN \tag{1}$$

Also note in Figure 2, that the additional wavelengths used as extra-capacity carriers ( $\lambda'_1, \lambda'_2, \lambda'_3$ ) are initially empty, not used, waiting to serve demanding ONUs that undergo a temporary capacity shortage. In this context, the dynamic channel allocation improves the system performance by enabling extra wavelength channels depending on a given demand. For modelling purposes, download requests from users are represented by state-dependent Poisson-arrival processes. Requests are modelled as coming from a limited number of sources (identifying one user with a source then  $S = 64$  per fixed wavelength). Each source has constant arrival intensity when the source is idle, and each source has arrival intensity zero when the source is busy, i.e.: ON/OFF sources. The arrival process is hence state-dependent. A source is idle during a time interval, which is exponentially distributed with rate  $\gamma$  and the source is busy (transmitting data) during an exponentially distributed time interval with rate  $\mu$ . These two parameters may be summarized in the offered traffic per idle source  $\beta$  as:

$$\beta = \frac{\gamma}{\mu} \tag{2}$$

All busy sources in a given instant of time equally share the available bit rate. The usage factor  $U$  is the fraction of time that a source is busy and is defined as:

$$U = \frac{S\beta}{(1 + \beta)^S} \tag{3}$$

$U$  can be deduced via a simple system with an isolated source that is assumed to change to the busy state when required (i.e.: it experiences no blocking) [15]. The steady state probabilities  $p(0), p(1)$  which are the proportion of time the process spends in idle and busy states, respectively, are calculated from the state transition diagram equilibrium equation between neighbouring states:

$$p(1) = S\beta p(0) \tag{4}$$

And the fact that:

$$P(0) + p(1) = 1 \tag{5}$$

Two user profiles are considered according to two downloading behaviours: a) *in-profile user* ( $U = 0.1$ , e.g. web browsing) and b) *out-of-profile user* ( $U = 0.9$ , HD video streaming). This teletraffic study assumes that the population of sources consists of in-profile users and a certain fraction of out-of-profile users that are randomly distributed. Under such conditions the study addresses the impact of having an increasingly large portion of out-of-profile users contributing to the perceived overload of the system. The performance evaluation has been carried out using an advanced modelling, analysis and simulation environment [16], which can simulate and solve the continuous-time Markov chains associated with the load distribution and traffic generation for the user profiles defined in the system model.

## RESULTS AND DISCUSSION

Figure 3 shows the average bit rate share per user with respect to the fraction of out-of-profile users. Two dashed lines, that mark the two nominal bit rates considered in this study  $N_1 = 155$  Mb/s and

$N_2=622$  Mb/s are included for reference. These bit rates correspond to the standard net bandwidths the ONU supports depending on the capacity of its line card interface. The rationale behind Figure 3 is to determine, for a specific lower bound value  $B$ , the maximum fraction  $f$  of out-of-profile users that can be supported while complying with  $B$ , stricter for high values of  $B$  (e.g. if  $e = 1, f_1 = 0.8235$  for  $B_1 = 155$  Mb/s, while  $f_2 = 0.1256$  for  $B_2 = 622$  Mb/s). That is, with 82.35% of out-of-profile users, a multicast bandwidth of 155 Mb/s is feasible to be shared among end users while 622 Mb/s can be shared when only a 12.56% of users have out-of-profile behaviour, in both cases when a maximum efficiency is considered. In any case, the nominal bit rate decreases as the number of out-of-profile users increases. Figure 4, shows the maximum fraction of out-of-profile users for  $B_1$  and  $B_2$  and any value of efficiency that can be supported assuming 0, 1, and 2 extra-capacity carriers ( $\lambda_F, \lambda'_1$  and  $\lambda'_2$ ). The value of  $\lambda_F$  defines the boundary between needing reconfigurable wavelengths or not. Thus, for a system with only two reconfigurable carriers, the value of  $\lambda'_2$  marks the inflection point where replicated-unicast connections are no longer advantageous in comparison to dedicated multicast wavelengths.

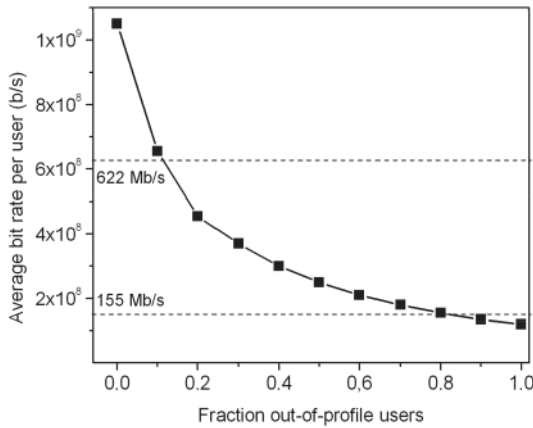

Figure 3. Average user bit rate as a function of the fraction of out-of-profile users.

In this case the network operator must face the choice of migrating multicast traffic to dedicated multicast wavelengths or disregarding lower bound commitment bit rate. Note that for high efficiency values curves are very close to each other, i.e., the range of the fraction of out-of-profile users where the extra-carriers avoid the need for dedicated

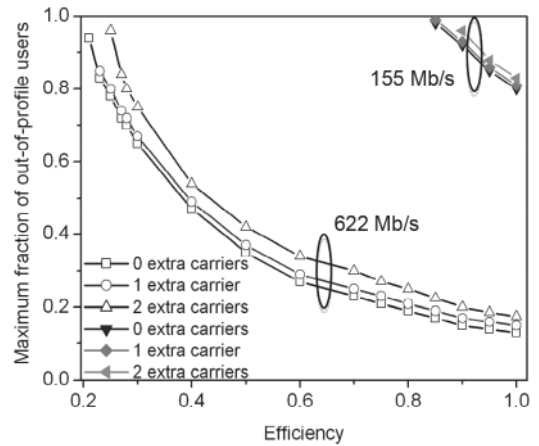

Figure 4. Maximum supported fraction of out-of-profile users.

multicast wavelengths is noteworthy small (e.g. if  $e = 1$ , for  $B_2 = 622$  Mb/s,  $\lambda_F = 0.1276, \lambda'_1 = 0.1484$ , and  $\lambda'_2 = 0.1780$ , so  $\lambda'_2 - \lambda_F = 5.04\%$ ), although this property relaxes for low efficiencies (e.g. if  $e = 0.3$ , for  $B_2 = 622$  Mb/s,  $\lambda_F = 0.6450, \lambda'_1 = 0.6789$ , and  $\lambda'_2 = 0.7563$ , so  $\lambda'_2 - \lambda_F = 11.13\%$ ). Also note the results for nominal bit rates lower than 622 Mb/s, e.g. 155 Mb/s, in this case the lower bandwidth consumption allows the system to support higher efficiencies for a high fraction of out-of-profile users. Finally, Figure 5 shows the average number of extra-capacity carriers simultaneously needed (in general, a real value), for  $e = 1$ . Since the number of wavelengths must be integer, the next largest integer value is included for reference. The value of  $\lambda'_n$  coincides with the discontinuities in the function,

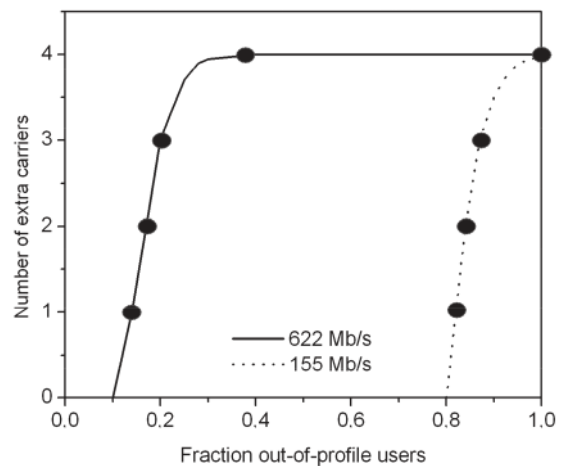

Figure 5. Average number of extra-capacity carriers simultaneously needed.



e.g. for  $B_1 = 155$  Mb/s,  $\lambda_F = 0.8212$ ,  $\lambda'_1 = 0.8390$ ,  $\lambda'_2 = 0.8705$ , etc., and again the highest value of efficiency can be supported by the extra-capacity carriers only within a narrow interval  $\lambda'_2 - \lambda_F = 4.93\%$  of the fraction of out-of-profile users.

## CONCLUSIONS

A simulation-based downlink performance evaluation that defines under which bulk-data traffic overload conditions a solution for multicast based on replicated-unicast connections is no longer helpful, in comparison to the dedicated multicast wavelength assignment, is presented in this paper. The study draws the conclusion that the specific boundary between these two alternatives depends on the nominal bit rate and the efficiency, and although the overload threshold depends mainly on the nominal bit rate, the range of the fraction of out-of-profile users where the extra-carriers avoid the need for selective multicast wavelengths depends on the efficiency parameter, being the fraction of tolerated additional out-of-profile users substantially small (about 5%) for high values of efficiency (very desirable from the user viewpoint), and slightly higher, around 12% of out-of-profile users, for lower values of efficiency (interesting from the network operator point of view).

This paper evaluated the network performance of multicast traffic distribution in future WDM-PON access networks. These evolved systems require upgrading both the OLT and ONU architectures in order to provide WDM connectivity between them. The fact that a stack of wavelengths is broadcasted, from the OLT to different PON featuring a dynamic channel allocation, requires the use of optical tunable filters at the ONU. In this context, it should be pointed out that currently no practical candidate technology performs fast selection, while there are several technologies for slow selection such as Fabry-Perot Filters (FPF) or Fiber Bragg Grating Filters (FBG). Therefore, further research is needed to implement wavelength-tunable optical filters featuring fast optical channel selection for future WDM-PON access networks.

## ACKNOWLEDGEMENT

The authors would like to acknowledge the Universidad Distrital Francisco José de Caldas for

supporting the realization of this paper and the Optical and Quantum Research Group at the Universidad Politécnica de Valencia for the contribution in valuable discussions around the topic.

## REFERENCES

- [1] J. Angelopoulos, H. Leligou, T. Argyriou, S. Zontos, E. Ringoot and T. Van Caenegem. "Efficient transport of packets with QoS in an FSAN-aligned GPON". *IEEE Comm. Mag.* Vol. 42 N° 2, pp. 92-98. February, 2004. ISSN: 0163-6804. DOI: 10.1109/MCOM.2003.1267106.
- [2] Cisco. "Cisco Visual Networking Index: Forecast and Methodology 2012-2017". Cisco. Date of visit: 1/05/2014. URL: [http://www.cisco.com/en/US/solutions/collateral/ns341/ns525/ns537/ns705/ns827/white\\_paper\\_c11-481360.pdf](http://www.cisco.com/en/US/solutions/collateral/ns341/ns525/ns537/ns705/ns827/white_paper_c11-481360.pdf)
- [3] W. Fenner. "Internet Group Management Protocol, Version 2". RFC 2236. November, 1997. Date of visit: 5/05/2014. URL: <http://www.rfc-editor.org/rfc/rfc2236.txt>
- [4] B. Fenner. "IANA Considerations for IPv4 Internet Group Management Protocol (IGMP)". BCP 57. RFC 3228. February, 2002. Date of visit: 5/05/2014. URL: <http://tools.ietf.org/html/rfc3228>
- [5] A. Adams, J. Nicholas and W. Siadak. "Protocol Independent Multicast – Dense Mode (PIM-DM) Prot. Specification (Revised)". RFC 3973, 2005. Date of visit: 5/05/2014. URL: <http://www.rfc-editor.org/rfc/rfc3973.txt>
- [6] C. Gee-Kung, A. Chowdhury, J. Zhensheng, C. Hung-Chang, H. Ming-Fang, Y. Jianjun and G. Ellinas. "Key Technologies of WDM-PON for Future Converged Optical Broadband Access Networks". *IEEE/OSA Journal of Optical Communications and Networking.* Vol. 1 N° 4, pp. C35-C50. September, 2009. ISSN: 1943-0620. DOI: 10.1364/JOCN.1.000C35.
- [7] J. Kani. "Enabling Technologies for Future Scalable and Flexible WDM-PON and WDM/TDM-PON Systems". *IEEE J. of Selected Topics in Quantum Electron.*, Vol. 16 N° 5, pp. 1290-1297. September, 2010. ISSN: 1077-260X. DOI: 10.1109/JSTQE.2009.2035640.

- [8] Y. Qiu and C.K. Chan. "A novel WDM passive optical network architecture supporting two independent multicast data streams". *Optical Fiber Technology*. Vol. 18 N° 1, pp. 29-33. January, 2012. ISSN: 1068-5200. DOI: 10.1016/j.yofte.2011.11.001.
- [9] G. Pandey, N. Agarwal and A. Goel. "WDM PON enhanced capacity architecture for unicast, multicast and broadcast through efficient sideband carrier modulation". Ninth International Conference on Wireless and Optical Communications Networks (WOCN). Indore, India. September, 2012.
- [10] F. Zhang, W. De Zhang and Z. Xu. "Broadcast/multicast capable carrier reuse WDM-PON". *Journal of Lightwave Technology*. Vol. 29 N° 15, pp. 2276-2284. August, 2011. ISSN: 0733-8724. DOI: 10.1109/JLT.2011.2158986.
- [11] Y. Qiu and C.K. Chan. "Optical overlay of multicast stream on a survivable WDM passive optical network". *IEEE Photon. Technol. Lett.* Vol. 25 N° 6, pp. 584-586. March, 2013. ISSN: 1041-1135. DOI: 10.1109/LPT.2013.2244877.
- [12] C. Calvin and K. Chan. "Survivable architectures and optical multicast overlay for WDM passive optical networks". 6th International Conference on Advanced Infocomm Technology (ICAIT). Hsinchu, Taiwan. July, 2013.
- [13] G. Puerto, J. Mora, B. Ortega and J. Capmany. "Selective Multicast in a Dynamic Wavelength Router for DWDM Converged Wired/Wireless Access Networks". Conference on Optical Fiber Communication. San Diego, USA. March, 2010.
- [14] Y. Hsueh, M. Rogge, S. Yamamoto and L. Kazovsky. "A highly flexible and efficient passive optical network employing dynamic wavelength allocation". *IEEE J. of Lightwave Technol.* Vol. 23 N° 1, pp. 277-286. January, 2005. ISSN: 0733-8724. DOI: 10.1109/JLT.2004.838811(410) 23.
- [15] V.B. Iversen. "Teletraffic engineering and network planning". Technical University of Denmark. 2010. Date of visit: 15/04/2014. URL: [ftp://ftp.dei.polimi.it/users/Flaminio.Borgonovo/Teoria/teletraffic\\_Iversen.pdf](ftp://ftp.dei.polimi.it/users/Flaminio.Borgonovo/Teoria/teletraffic_Iversen.pdf)
- [16] W. Sanders. "Möbius Manual, Version 2.4". University of Illinois. December, 2012. Date of visit: 15/04/2014. URL: <https://www.mobius.illinois.edu/docs/MobiusManual.pdf>