

1971

Direct design of a portal frame

Angel Fajardo Ugaz
Portland State University

Follow this and additional works at: https://pdxscholar.library.pdx.edu/open_access_etds



Part of the [Computer-Aided Engineering and Design Commons](#), [Structural Engineering Commons](#), and the [Structural Materials Commons](#)

Let us know how access to this document benefits you.

Recommended Citation

Ugaz, Angel Fajardo, "Direct design of a portal frame" (1971). *Dissertations and Theses*. Paper 1480. <https://doi.org/10.15760/etd.1479>

This Thesis is brought to you for free and open access. It has been accepted for inclusion in Dissertations and Theses by an authorized administrator of PDXScholar. Please contact us if we can make this document more accessible: pdxscholar@pdx.edu.

AN ABSTRACT OF THE THESIS OF ANGEL FAJARDO UGAZ for the Master of Science
in Applied Science presented May 21, 1971.

Title: Direct Design of a Portal Frame

APPROVED BY MEMBERS OF THE THESIS COMMITTEE

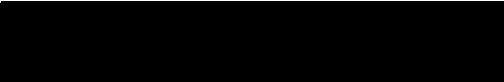
Shriniwas N. Pagay, Chairman

Harry J. White

HaciK Erzurumlu

This investigation was undertaken to develop plastic design aids to be used in the direct design of optimum frames. It uses the concept of minimum weight of plastically designed steel frames, and the concept of linear programming to obtain general solutions. Among the special characteristics of this study are: A. The integration of both gravity and combined loading conditions into one linear programming problem. B. The application of the revised simplex method to the dual of a parametric original problem. C. The application of A and B above in the development of design aids for the optimum design of symmetrical single-bay, single-story portal frame. Specifically, design graphs for different height to span ratios and different vertical load to lateral load ratios are developed. The use of these graphs does not require the knowledge of linear programming or computers on the part of the designer.

DIRECT DESIGN OF A PORTAL FRAME

by

Angel Fajardo Ugaz

A thesis submitted in partial fulfillment of the
requirements for the degree of

MASTER OF SCIENCE
in
APPLIED SCIENCE

Portland State University
1971

TO THE OFFICE OF GRADUATE STUDIES:

The members of the committee approve the thesis of
Angel Fajardo Ugaz presented May 21, 1971.

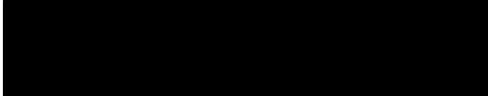

Shriniwas N. Pagay, Chairman

Harry J. White

Hacik Erzurumlu

APPROVED:

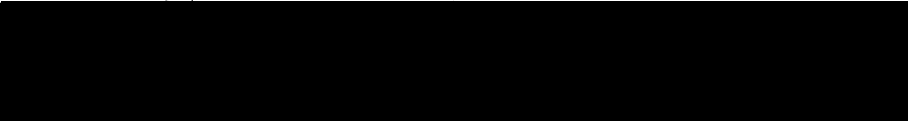
Nan-Teh Hsu, Acting Head, Department of Applied Science

David T. Clark, Dean of Graduate Studies

NOTATION

A	Current basic matrix of the revised simplex
B^{-1}	Transformation matrix
C	Coefficients of the objective function equation
C_B	Coefficients of the basic variables in the objective function
C_R	Coefficients of the nonbasic variables in the objective function
f	Plastic safety factor
h	Height of portal frame
K	Load ratio
L	Span of portal frame
M_1	Plastic moment of column
M_2	Plastic moment of beam
M_a	M_1/PL
M_b	M_2/PL
P	Load
Q	Gravity load
R	Current nonbasic matrix
S_i	Slack variables
W	Dual Variable of M
X	Height to span ratio
Y	Transform vector coefficient of entering variable
Z	Plastic modulus
Z_p	Objective function of primal
Z_D	Objective function of dual

TABLE OF CONTENTS

NOTATION

I.	Introduction	1
	1. General.	1
	2. Scope of the Study	2
II.	Plastic Design	4
III.	Minimum Weight Design.	9
IV.	Study of a One-Bay, One-Story, Fixed-Ended Portal Frame.	16
	1. Introduction	16
	2. One-Bay, One-Story, Fixed-Ended Portal Frame	16
	3. The Linear Programming Problem	23
	4. Example Problem.	36
	5. Concluding Remarks	42
V.	Study of a One-Bay, One-Story, Hinged-Ended Portal Frame	43
	1. Introduction	43
	2. One-Bay, One-Story, Hinged-Ended Portal Frame.	43
	3. The Linear Programming Problem	46
	4. Example Problem.	50
	5. Concluding Remarks	54
VI.	Summary and Conclusions	55
	1. Summary.	55
	2. Conclusions.	56
APPENDIX.		57
A.	Revised Simplex Method of Linear Programming	57
B.	1. Computer Program to Check Relations.	64
	2. Possible Basic Solutions Table	66
	3. Collapse Mechanism Obtained From B.1	67
C.	Graphs 1 and 2	69
D.	Reference.	72

I. INTRODUCTION

I. 1. General. The total design of a structure may be divided into the following phases:

- 1) Information and data acquisition about the structure.
- 2) Preliminary design.
- 3) Rigorous analysis and design.
- 4) Documentation.

Once the applied loads and the geometry of the structure are known, the traditional approach has been to consider a preliminary structure, analyze it, and improve it. In contrast with this trial and error procedure, the minimum weight design generates automatically the size of structural members to be used. This method of direct design combines the techniques of linear programming with the plastic design of structures. Minimum weight of plastically designed steel frames has been studied extensively in the last two decades; Foulkes^{1*} applied the concept of Foulkes mechanisms to obtain the minimum weight of structure. This concept was also used by Heyman and Prager² who developed a design method that automatically furnishes the minimum weight design. Rubinstein and Karagozian³ introduced the use of linear programming in the minimum weight design. Linear programming has also been treated by Bigelow and Gaylord⁴ (who added column buckling constraints) and others.⁵

In the above studies the required moments are found when the loads and configuration of the frames are given. If different loading conditions or different frame dimensions are to be studied, a new linear

*Superscripts refer to reference numbers in Appendix D.

programming problem must be solved for every loading and for every change of the dimensions. Moreover, the computation of the required design moments requires a knowledge of linear programming and the use of computers.

I. 2. Scope of this Study. The purpose of this study is to develop direct design aids which will provide optimum values of the required moments of a structure. In contrast with the preceding investigations, this study introduces the following new concepts: (a) The integration of both gravity and combined loading into one linear programming problem which gives better designs than the individual approach. (b) The development of general solutions for optimum plastic design. These general solutions, presented in a graph, chart or table, would provide directly the moments required for an optimum design for various loads and dimensions of a structure. (c) In order to attain the general solution a new procedure is introduced in Chapter IV, a brief description of which follows: 1. The objective function¹⁰ and constraint equations are written in a parametric form as a function of the plastic moments where the "C"* coefficients of the objective function and the b vector are parameters. These parameters are related to the loads and to the frame dimensions. 2. It solves the dual of the original problem using the Revised Simplex Method,⁹ but instead of operating transformations on the constant numerical values, it operates on the parameters. 3. The solutions are found for different ranges of values of the parameter which meet the optimality condition $C_R - C_B B^{-1} < 0$.

*See Appendix E for Notation

In Chapter IV, Graph No. 1 is developed to illustrate the above concepts and a design example is given to show its practical application. From this graph the optimum design of a one-bay, one-story, fixed-ended portal frame may be read directly, after computing the parameters X and K . Here, X is the height to span and $2K$, the ratio of vertical to lateral load. It should be pointed out that these concepts can be applied to multistory multiple-bay frames.

Chapter IV studies one-bay, one-story, hinged-ended, portal frames. Because of the special characteristics of the linear programming problem, a semigraphical method is used. Graph No. 2 is developed as a design aid in this manner, and a design example to illustrate its use is provided.

Chapters II and III discuss briefly the widely known concepts of plastic design and minimum weight design, and Appendix A describes the computational procedure of the Revised Simplex Method.

To this date, the concepts a, b, and c mentioned above have not been applied to the optimum design of framed structures; neither graphs No. 1 or 2 have been published before.

II. PLASTIC DESIGN

Traditional elastic design has for many years believed in the concept that the maximum load which a structure could support was that which first caused a stress equal to the yield point of the material somewhere in the structure. Ductile materials, however, do not fail until a great deal of yielding is reached. "When the stress at one point in a ductile steel structure reaches the yield point, that part of the structure will yield locally, permitting some readjustment of the stresses. Should the load be increased, the stress at the point in question will remain approximately constant, thereby requiring the less stressed parts of the structure to support the load increase. It is true that statically determinate structures can resist little load in excess of the amount that causes the yield stress to first develop at some point. For statically indeterminate structures, however, the load increase can be quite large; and these structures are said to have the happy facility of spreading out overloads due to the steel's ductility."⁶

In the plastic theory, rather than basing designs on the allowable stress method the design is based on considering the greatest load which can be carried by the structure as a unit.

Consider a beam with symmetric cross section composed of ductile material having an elastoplastic stress-strain diagram (identical in tension and compression) as shown in Fig. 2.1. Assuming that initially plane cross-sections remain plane as the applied bending moment increases, the strain distribution will vary as shown in Fig. 2.2.A. The corresponding distributions of bending stress are shown in Fig. 2.2.B. If the magnitude of strain could increase indefinitely, the stress distribution would approach that of Fig. 2.2.C. The bending moment corresponding to this

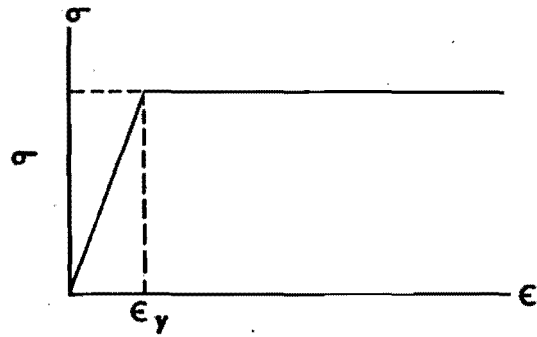

FIG. 2-1 Elasto-plastic stress-strain diagram

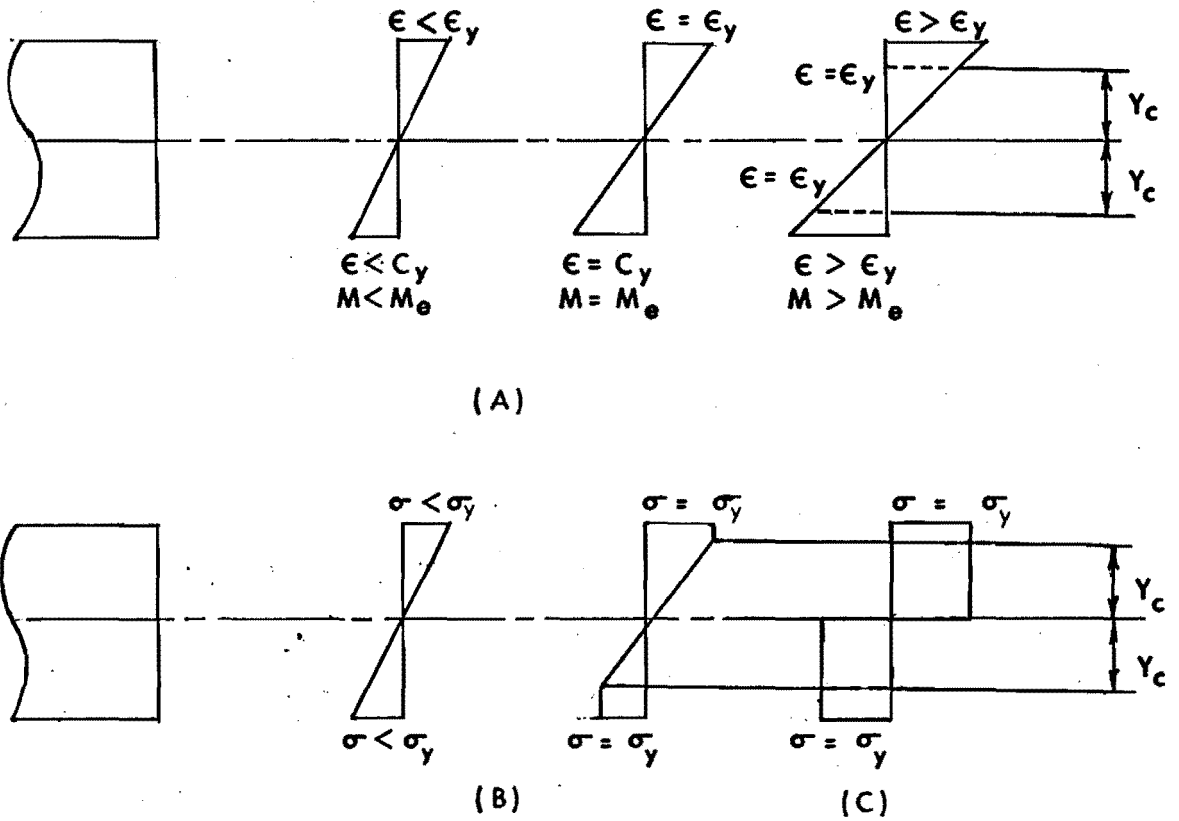

FIG. 2-2 Elastic and inelastic strain and stress distribution in beam subjected to bending

C. Fully plastic stress distribution

distribution is referred to as the "fully plastic" bending moment and is often denoted by M_p . For a typical I-Beam, for example, $M_p = 1.15 M_e$ where M_e is the maximum bending moment corresponding to entirely elastic behavior.

As the fully plastic moment is approached, the curvature of the beam increases sharply. Figure 2.4 shows the relationship between moment and curvature for a typical I-beam shape. In the immediate vicinity of a point in a beam at which the bending moment approaches M_p large rotations will occur. This phenomenon is referred to as the formation of a "plastic hinge."

As a consequence of the very nearly bilinear moment-curvature relation for some sections (Fig. 2.4), we could assume entirely elastic behavior until the moment reaches M_p (Fig. 2.5), at which point a plastic hinge will form.

Utilizing the concept of plastic hinges, structures transmitting bending moments may be designed on the basis of collapse at ultimate load. Furthermore, indeterminate structures will not collapse at the formation of the first plastic hinge. Rather, as will be shown, collapse will occur only after the formation of a sufficient number of plastic hinges to transform the structure into a mechanism. Before considering design, however, it is necessary to discuss the most applicable method of analysis, the "kinematic method." It will be assumed throughout, that the process of hinge formation is independent of axial or shear forces, that all loads increase in proportion, and that there is no instability other than that associated with transformation of the structure into a mechanism.

The kinematic method of analysis is based on a theorem which provides an upper bound to the collapse load of a structure. The statement of this

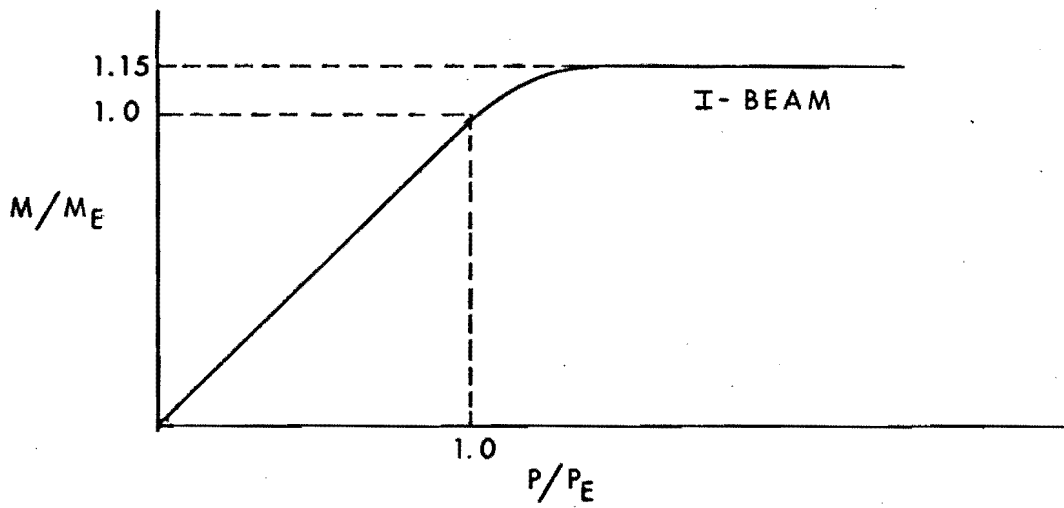

FIG. 2.4 Moment-curvature relations ($p = \text{curvature}$).

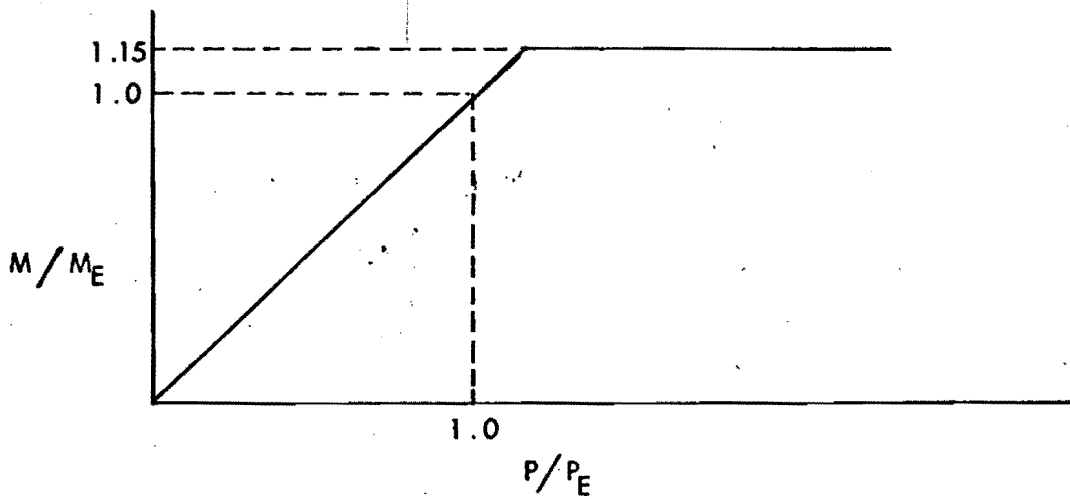

FIG. 2-5 Idealized moment-curvature relation.

theorem is as follows: "The actual limiting load intensity on a structure is the smallest intensity that can be computed by arbitrarily inserting an adequate number of plastic hinges to form a mechanism, and equating the work dissipated in the hinges to the work of the applied loads"⁶ (i.e., by applying the principle of virtual work to an assumed mechanism and computing the load corresponding to the formation of the mechanism).

To find the actual collapse load utilizing this theorem it is therefore necessary to consider all possible mechanisms for the structure.

In order to reverse the analysis process, and design a frame of specified geometry subjected to specified loads, it is necessary to regard the fully plastic moment of each component as a design parameter. In this case, it is not known at the outset whether the column will be weaker or stronger than the beam. Hence, mechanisms considered must include both possibilities. Consideration of mechanisms for the purpose of design leads to a set of constraints on the allowable values of fully plastic moments. It is also necessary to define what will constitute an optimum design for a frame. With minimum weight again chosen as the criterion, a relationship between structural weight and fully plastic moments of the various components is required.

III. MINIMUM WEIGHT DESIGN

The optimum plastic design of frames has been investigated by many authors and most of them agree that the total weight of the members furnishes a good measure of the total cost. Thus we shall study designs for minimum weight.

A relationship between structural weight and plastic modulus of the various components may be observed⁶ in figure 3.1 where the weight per unit length is drawn against $Z = \frac{M_p}{\sigma_y}$

These curves satisfy the equation:

$$q = K_1 \left(\frac{M_p}{\sigma_y} \right)^\alpha \quad (3.1)$$

For WF, $\alpha \approx 2/3$ and making $K_1 = K_2$

$$q = K_2 M_p^{2/3} \quad (3.2)$$

This is shown in figure 3.2

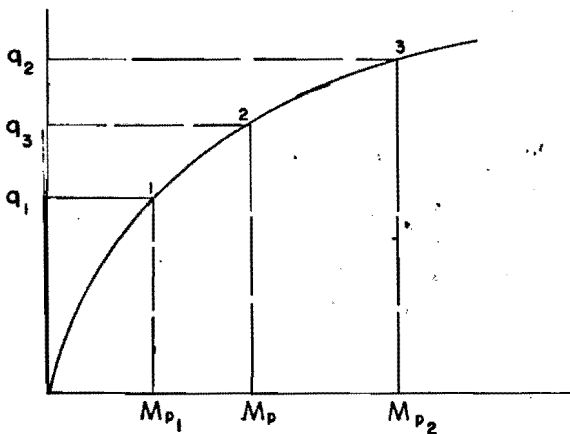

FIG. 3.2

$$q_3 = (1/2)(q_1 + q_2)$$

$$\frac{M_{p2}}{M_{p1}} < 2$$

For a ratio of M_{p2} over M_{p1} of less than 2, we can substitute Eq. 3.2 by the equation of the tangent at a point 3 which the abscissa is the arithmetic mean of the abscissa of the end points 1 and 2, the error incurred is of the order of 1%.

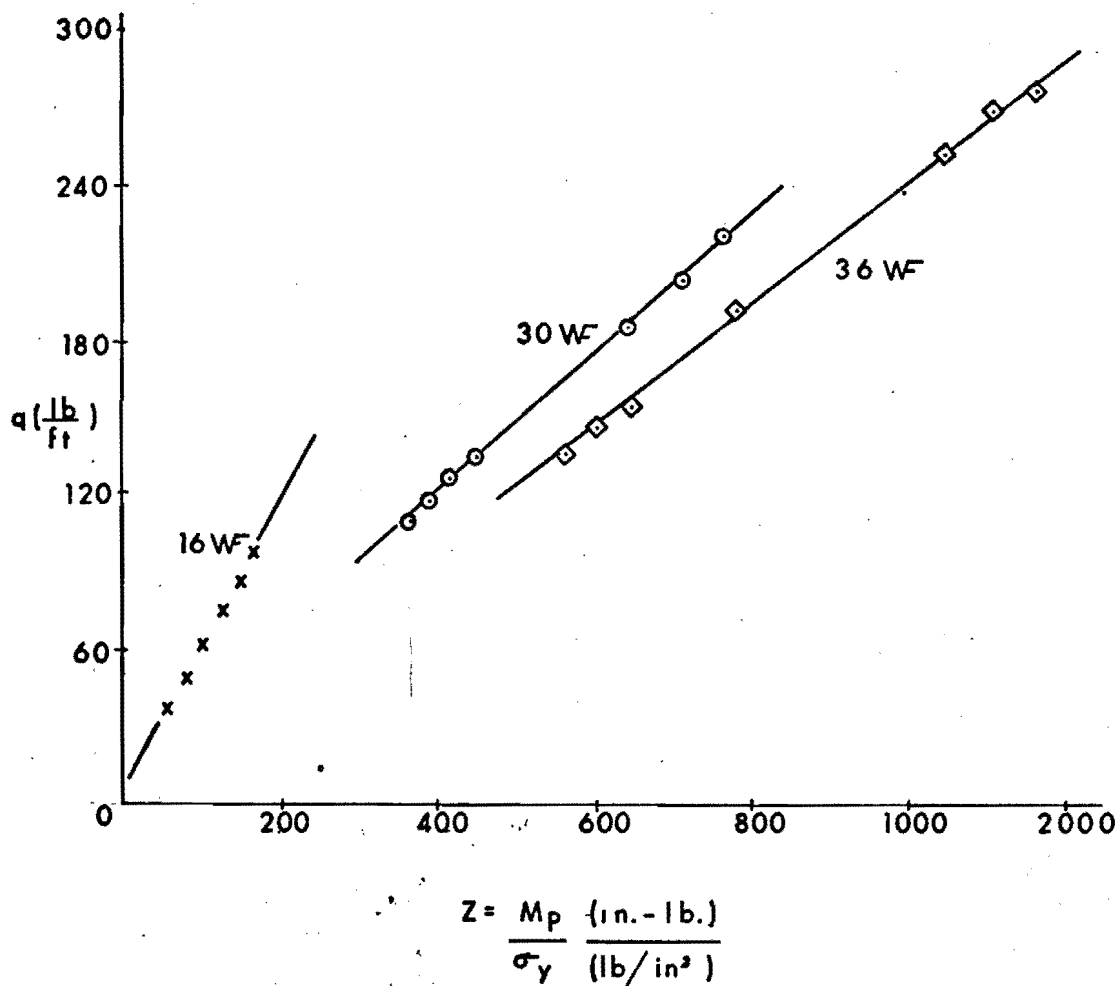

FIG. 3.1. Weight per foot vs. plastic Modulus for standard wide-flange shapes. (Ref. 6)

The equation of the target is then $q = a + b M_p$. The total weight of the structure will be $\sum q L_i = \sum L_i (a + b M_{pi}) = a \sum L_i + b \sum M_{pi} L_i$. Where L_i is the length of member i , M_{pi} its plastic moment capacity and, n the number of members.

When the dimensions of the frame are given the term $a \sum L_i$ is constant so the objective function B depends only on M_p and L_i , thus to find the minimum weight we should minimize $B = \sum M_p L$.

The constraints are determined by all the possible collapse mechanisms and applying the virtual work equations. The external work inflicted by the loads must be less or at best equal to the strain energy or internal work capacity of the frame. That is:

$$U \geq \delta W_E$$

$$\sum M_{pi} \theta_i \geq \sum P_j L_j \theta_j \quad \text{for each mechanism}$$

Example: Design the frame shown in Fig. 3.3, which is braced against sideway.

The objective function $B = \sum M_p L$

$$B = 2M_1 (0.4L) + M_2(L) = 0.8M_1 L + M_2 L = (0.8M_1 + M_2) L$$

The collapse mechanisms and their energy equations are shown in Fig. 3.4. If the objective function is divided by a constant (PL^2) , the optimum solution will not change. Thus,

$$B = \frac{0.8M_1}{PL} + \frac{M_2}{PL}$$

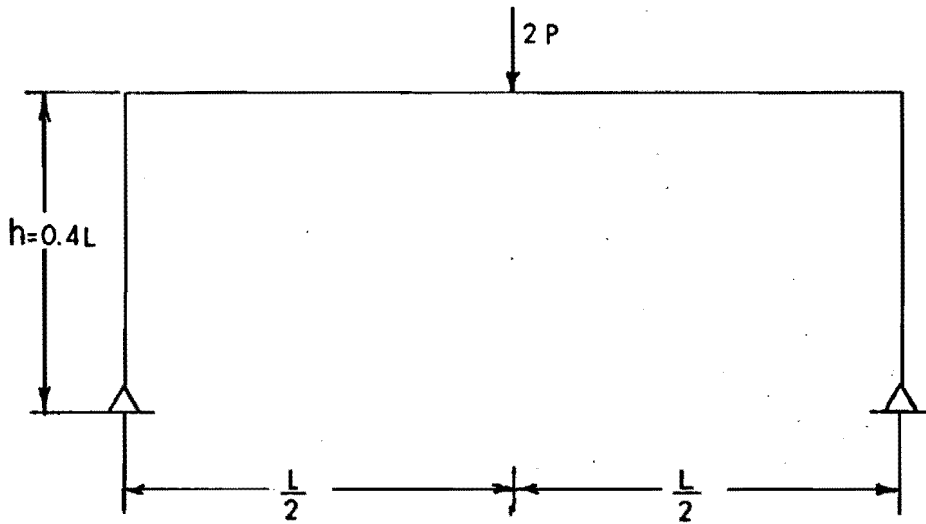
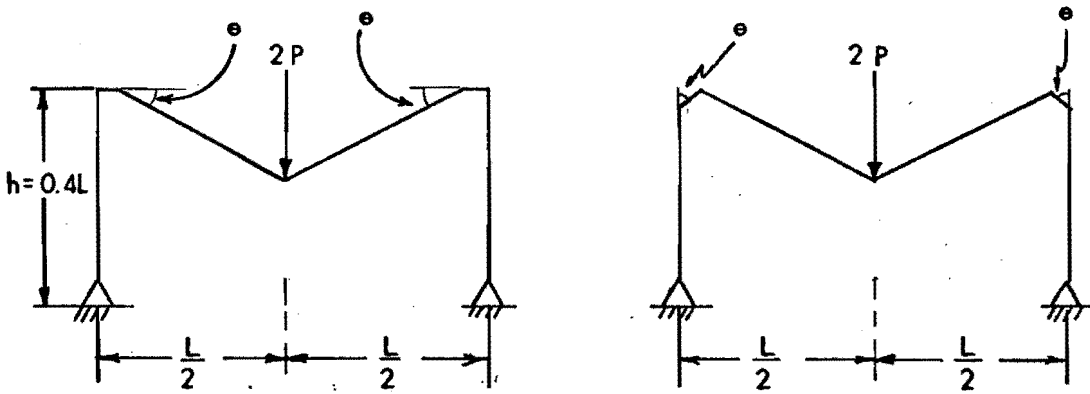

FIG. 3.3



$$M_2(\theta) + M_2(2\theta) + M_2(\theta) \geq 2P\left(\frac{L}{2}\right)\theta$$

$$\frac{4M_2}{PL} \geq 1$$

$$(M_1 > M_2)$$

$$M_1(\theta) + M_2(2\theta) + M_1(\theta) \geq 2P\left(\frac{L}{2}\right)\theta$$

$$\frac{2M_1}{PL} + \frac{2M_2}{PL} \geq 1$$

$$(M_2 > M_1)$$

FIG. 3.4

The linear programming problem is

$$\text{Minimize } B = \frac{0.8M_1}{PL} + \frac{M_2}{PL}$$

$$\text{Subject to } \frac{4M_2}{PL} \geq 1$$

$$\frac{2M_1}{PL} + \frac{2M_2}{PL} \geq 1$$

$$\frac{M_1}{PL}, \frac{M_2}{PL} \geq 0$$

This could be written in the Matrix form

$$\text{Minimize } (0.8, 1) \begin{bmatrix} \frac{M_1}{PL} \\ \frac{M_2}{PL} \end{bmatrix} = \bar{C}'\bar{M}$$

$$\text{S.t. } \begin{bmatrix} 0 & 4 \\ 0 & 2 \end{bmatrix} \begin{bmatrix} \frac{M_1}{PL} \\ \frac{M_2}{PL} \end{bmatrix} \geq \begin{bmatrix} 1 \\ 1 \end{bmatrix} = \bar{A}\bar{M} \geq B$$

$$\text{Or Minimize } \bar{C}'\bar{M}$$

$$\text{S.t. } \bar{A}\bar{M} \geq B$$

A graphic solution is shown in Fig. 3.5. The linear constraints divide the area into two; the area of Feasible designs--where the combinations of values of M_1 and M_2 will not violate the constraints, thus giving a safe structure, and the area of unfeasible designs--where any point

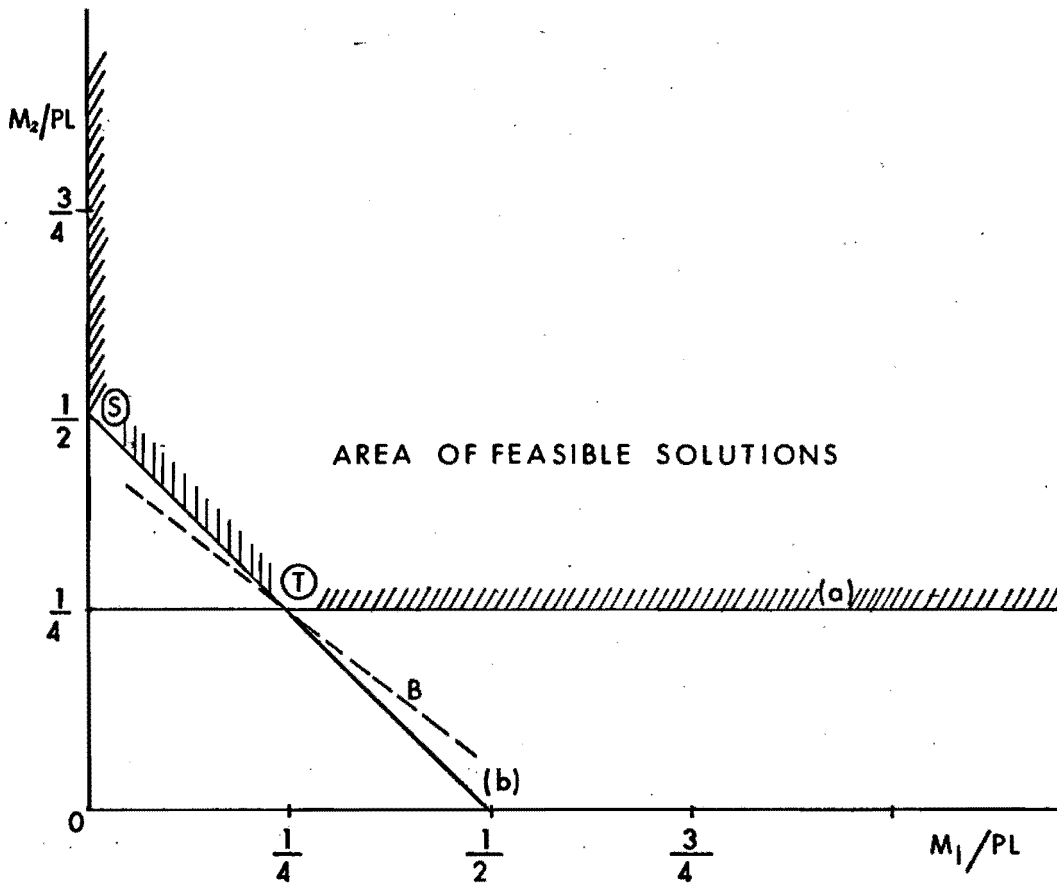

$$(a) \quad \frac{4 M_2}{PL} \leq 1$$

$$(b) \quad \frac{2 M_1}{PL} + \frac{2 M_2}{PL} \leq 1$$

$$M_1 \geq 0, \quad M_2 \geq 0$$

$$B = \left(\frac{0.8 M_1}{PL} + \frac{M_2}{PL} \right) = \frac{9}{20}$$

FIG. 3.5

represents a frame that will not be able to support the load. The points "r" and "s" where the constraints intersect each other on the boundary of the feasible solutions are called "Basic Solutions," one of which is the optimum solution. The solution is

$$M_1 = M_2 = PL/4, \quad B = (3/4)PL^2$$

In the case of three or more variables, the graphic solution becomes cumbersome and impossible. The methods of Linear Programming will be used (see appendix) for the subsequent problem.

Remarks. The optimum design of the frame in the example will give $Z = \frac{M_p}{\sigma_y} = \frac{PL/4}{\sigma_y} = \frac{PL}{4\sigma_y}$ which, of course, will vary depending on P, L and σ_y , but for a determined value of P and L, we are not apt to find a rolled section with exactly that plastic modulus because there is only a limited number of sections available. The solution will then be

$$M_1 = M_2 > PL/4, \quad Z > \frac{PL}{4\sigma_y}$$

These values will not break any of the constraints. If $M_1 = PL/4$ and $M_2 = PL/4$ meet this requirement so will any value of M_1 and M_2 greater than $PL/4$. For an exact solution we should apply a method of "Discrete Linear Programming" substituting M by Z_y and using the standard shapes; however, this method consumes a lot of computer time and is expensive. Another way to tackle this problem is to use the linear programming solution as an initial solution and by systematically combining the available sections in the neighborhood, the best design is obtained.

IV. STUDY OF A ONE-BAY ONE-STORY FIXED-ENDED PORTAL FRAME

IV. 1. Introduction. In this chapter a design aid (Graph No. 1) will be developed for a one-bay, one-story, fixed-ended portal frame. This design aid provides not only optimum design values, but also the corresponding mechanisms. It starts by finding the basic mechanisms. From the basic mechanisms all the possible collapse mechanisms are obtained, which in turn, provide the energy constraints. These linear constraints, for both gravity and combined loads, are integrated into one set. The objective function equation was developed in Chapter III as: $\sum B = \sum_{pi} L_i$, which is to be minimized. The solution will be found by applying the revised simplex method to the dual of the original problem. However, instead of having constant coefficients in the objective function and in the righthand side values (b vector), we have some function of the parameters X and K. General solutions are found for values of X and K that meet the optimality condition, that is $C_R - C_B B^{-1} < 0$. A graph presenting these solutions is constructed. A numerical example follows in Section IV. 4. to illustrate the use of Graph No. 1 which gives the moments required for an optimum design, given the loads and the frame dimensions.

IV. 2. One-Bay, One-Story, Fixed-Ended Portal Frame. Consider the frame shown in Fig. 4.1 where the plastic moment of each column is M_1 and the plastic moment of the beam is M_2 . There are seven potentially critical sections and the redundancy is $6-3=3$. The number of linearly independent basic mechanisms is $7-3=4$. These are shown in Fig. 4.2. For a combined loading condition, all possible mechanisms and their corresponding energy constraint equations are shown in Fig. 4.3.

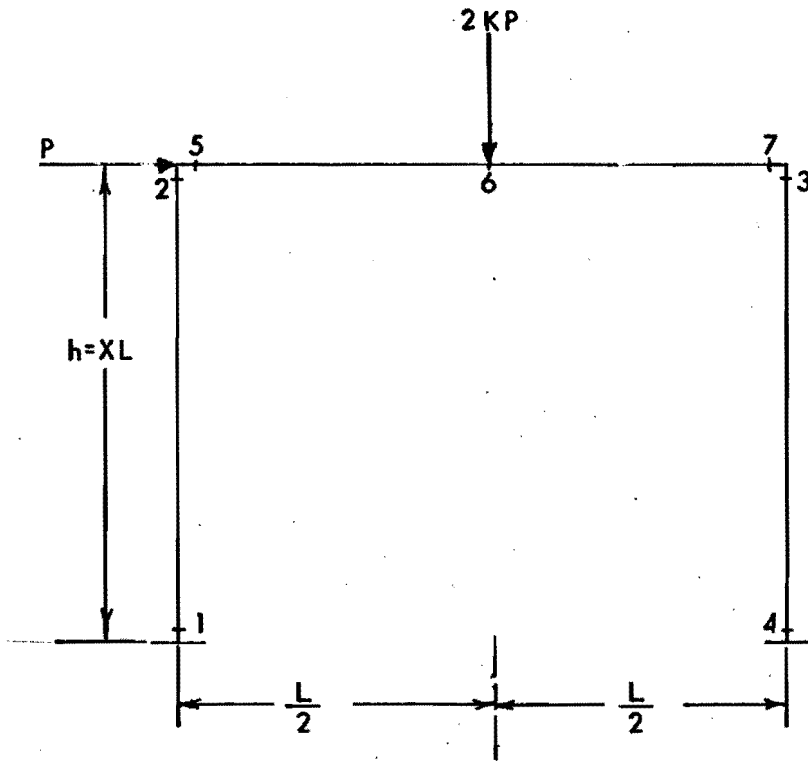
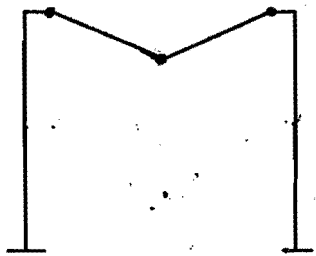
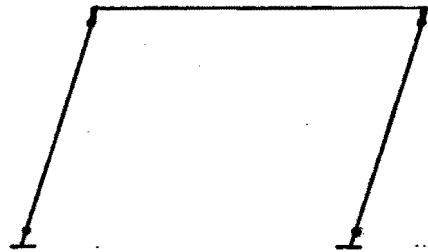

FIG. 4.1



Beam mechanism



Panel mechanism



Joint mechanisms

BASIC INDEPENDENT MECHANISMS

FIG. 4.2

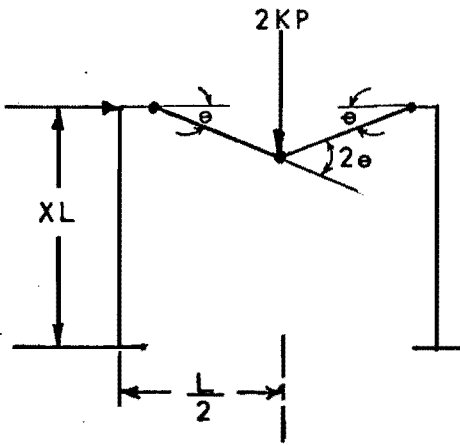

(a) $4M_2 \leq KPL$

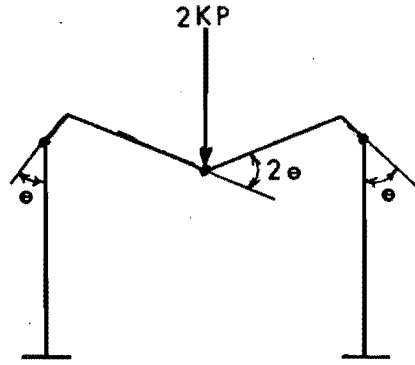

(b) $2M_1 + 2M_2 \leq KPL$

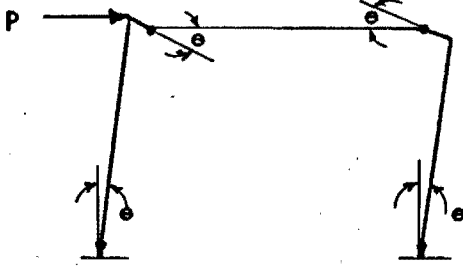

(b') $2M_1 + 2M_2 \leq XPL$

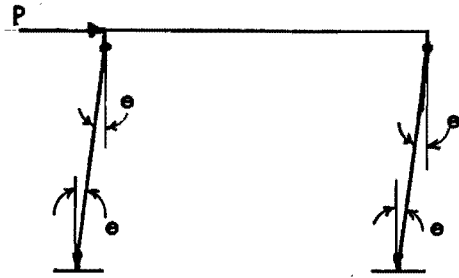

(c) $4M_1 \leq XPL$

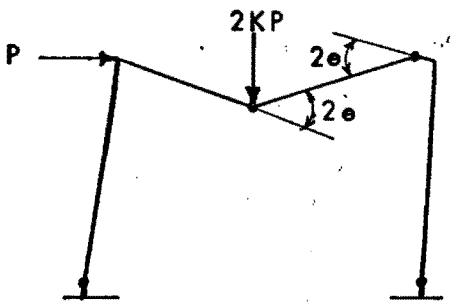

(d) $2M_1 + 4M_2 \leq (X+K)PL$

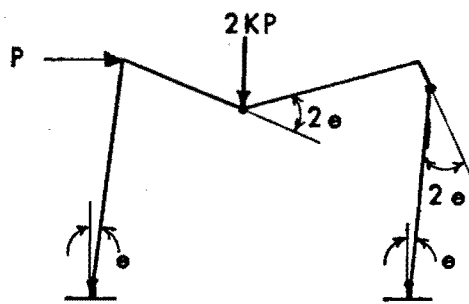

(e) $4M_1 + 2M_2 \leq (X+K)PL$

FIG. 4.3 COLLAPSE MECHANISMS

We should use either (b) or (b¹) depending if $K > X$ or $K < X$, respectively. The objective function is:

$$B = \frac{B^1}{PL^2} = 2X \frac{M_1}{PL} + \frac{M_2}{PL}$$

Written in matrix form we can state the problem:

$$\text{Minimize } B = (2X, 1) \begin{bmatrix} \frac{M_1}{PL} \\ \frac{M_2}{PL} \end{bmatrix}$$

$$\text{S.t. } \begin{bmatrix} 0 & 4 \\ 2 & 2 \\ 4 & 0 \\ 2 & 4 \\ 4 & 2 \end{bmatrix} \begin{bmatrix} \frac{M_1}{PL} \\ \frac{M_2}{PL} \end{bmatrix} \geq \begin{bmatrix} K \\ K \text{ or } X \\ X \\ X + K \\ X + K \end{bmatrix}$$

For gravity loads there are only two relevant mechanisms. (a) and (b).

$$Q = \frac{1.85}{1.40} 2KP = 1.321(2KP)$$

$$(a_1) \quad 4M_2 \geq QL/2 \quad \text{or} \quad 8 \frac{M_2}{QL} \geq 1$$

$$(b_1) \quad 2M_1 + 2M_2 \geq QL/2 \quad \text{or} \quad 4 \frac{M_1}{QL} + 4 \frac{M_2}{QL} \geq 1$$

The objective function is:

$$B = \sum M_i L_i = 2X M_1 L + M_2 L$$

$$B = \frac{B}{QL^2} = 2X \frac{M_1}{QL} + \frac{M_2}{QL}$$

A graphical solution of this linear programming problem will give (see Fig. 4.4)

I) For $X < 1/2$

$$M_1 = M_2 = (1/8) QL$$

Collapse Mechanisms $a_1, b_1,$

II) For $X > 1/2$

$$M_1 = 0$$

$$M_2 = (1/4) QL$$

Collapse Mechanism b_1

For the latter condition M_1 is determined either by column requirements or by the combined loading requirements. In either case a M_2 may be found from equation b_1 and checked against equation a_1 .

The usual way of solving a design problem would be to find the combined and gravity load solutions independently and to use the loading condition, which is more critical. However, an integrated approach may be used, which is developed in the following paragraphs.

The gravity load objective function is:

$$\text{Minimize } B = 2x \frac{M_1}{QL} + \frac{M_2}{QL}$$

$$\text{But, } Q = 1.321 (2KP)$$

$$\text{Thus, } B = \frac{2x M_1}{1.321(2K)PL} + \frac{M_2}{1.321(2K)PL}$$

Multiplying B by 1.321(2K) we could write:

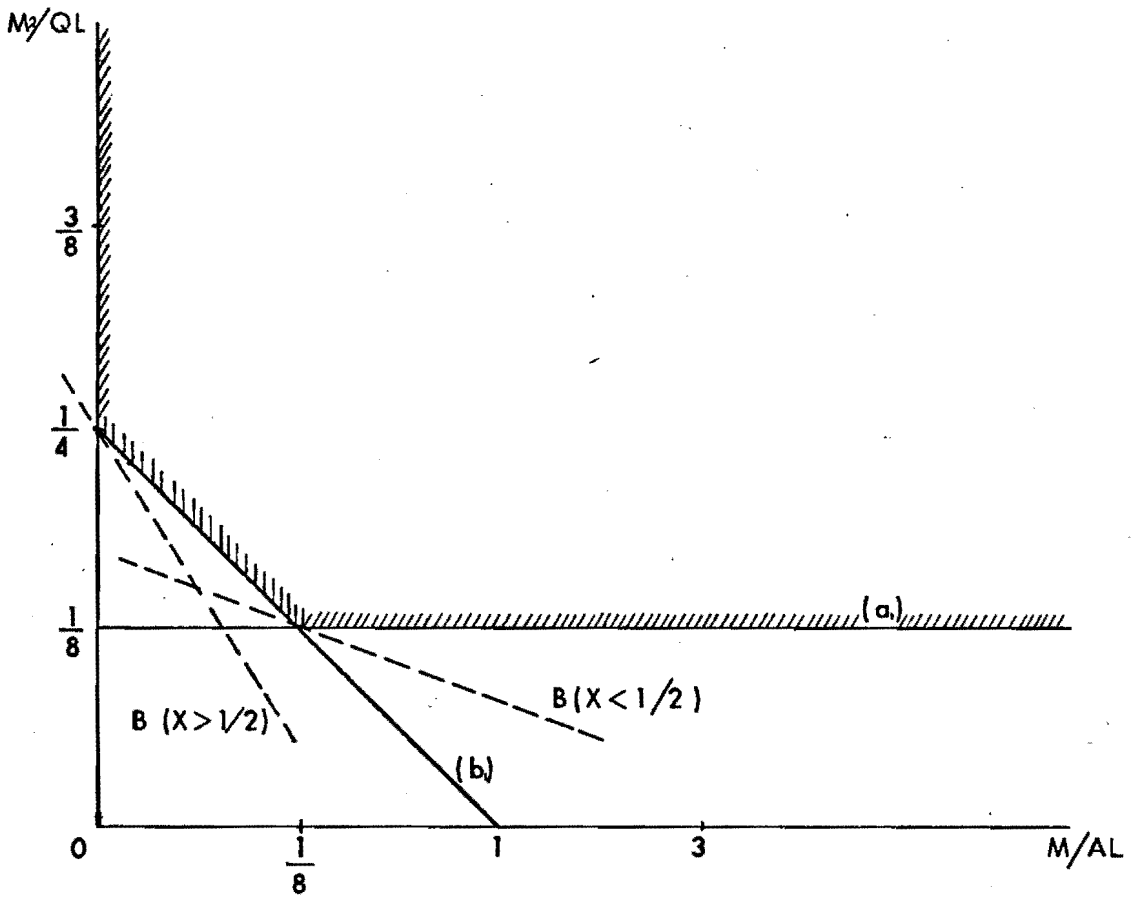

$$(a) \quad \frac{8M_2}{QL} \geq 1$$

$$(b) \quad \frac{4M_1}{QL} + \frac{4M_2}{QL} \geq 1$$

$$M \geq 0, \quad M \geq 0$$

$$B = \frac{2XM_1}{QL} + \frac{M_2}{QL}$$

FIG. 4.4 GRAPHIC SOLUTION TO GRAVITY LOADING

$$B = 2X \frac{M_1}{PL} + \frac{M_2}{PL} \quad \text{which is the same objective function}$$

as the one for the combined load. Substituting $Q = 1.321(2KP)$ in equations a_1 and b_1 :

$$(a_1) \quad \frac{8 M_2}{1.321(2KP)L} \geq 1 \quad \text{or} \quad \frac{4 M_2}{PL} \geq 1.321K$$

$$(b_1) \quad \frac{4 M_1}{1.321(2KP)L} + \frac{4 M_2}{1.321(2KP)L} \geq 1$$

$$\text{or,} \quad \frac{2M_1}{PL} + \frac{2M_2}{PL} \geq 1.321K$$

Considering that the combined loading and the gravity loading have the same objective function we could integrate the two sets of constraints and we will have:

$$(a) \quad \frac{4M_2}{PL} \geq K$$

$$(b) \quad \frac{2M_1}{PL} + \frac{2M_2}{PL} \geq K$$

$$(b^1) \quad \frac{2M_1}{PL} + \frac{2M_2}{PL} \geq X$$

$$(c) \quad \frac{4M_1}{PL} \geq X$$

$$(d) \quad \frac{2M_1}{PL} + \frac{4M_2}{PL} \geq X + K$$

$$(e) \quad \frac{4M_1}{PL} + \frac{2M_2}{PL} \geq X + K$$

$$(a_1) \quad \frac{4M_2}{PL} \geq 1.321K$$

$$(b_1) \quad \frac{2M_1}{PL} + \frac{2M_2}{PL} \geq 1.321K$$

$$\frac{M_1}{PL}, \quad \frac{M_2}{PL} \geq 0$$

Observing that a_1 contains a ; and b_1 contains b , the a and b could be eliminated. Making $M_1/PL = M_a$ and $M_2/PL = M_b$, we could state our problem as:

$$\text{Minimize} \quad 2X M_a + M_b$$

$$\text{S.t.} \quad (a_1) \quad 4M_b \geq 1.321K$$

$$(b_1) \quad 2M_a + 2M_b \geq 1.321K$$

$$(b^1) \quad 2M_a + 2M_b \geq X$$

$$(c) \quad 4M_a \geq X$$

$$(d) \quad 2M_a + 4M_b \geq X + K$$

$$(e) \quad 4M_a + 2M_b \geq X + K$$

$$M_a, M_b \geq 0$$

IV. 3. The Linear Programming Problem.

$$\text{Minimize} \quad (2X - 1) \begin{bmatrix} M_a \\ M_b \end{bmatrix}$$

$$\text{S.t.} \quad \begin{bmatrix} 0 & 4 \\ 2 & 2 \\ 2 & 2 \\ 4 & 0 \\ 2 & 2 \end{bmatrix} \begin{bmatrix} M_a \\ M_b \end{bmatrix} \geq \begin{bmatrix} 1.321K \\ 1.321K \text{ or } X \\ X \\ X + K \\ X + K \end{bmatrix}$$

$$M_a, M_b \geq 0$$

The dual would be:

$$\text{Maximum} \quad 1.321 K W_1 + \begin{bmatrix} 1.321K \\ X \end{bmatrix} W_2 + X W_3 + (X + K) W_4 + (X+K) W_5$$

$$\text{S.t.} \quad 0W_1 + 2W_2 + 4W_3 + 2W_4 + 4W_5 \leq 2X$$

$$4W_1 + 2W_2 + 0W_3 + 4W_4 + 2W_5 \leq 1$$

Applying the revised simplex method (see Appendix A)

$$W_b = \begin{bmatrix} S_1 \\ S_2 \end{bmatrix} = \begin{bmatrix} 2X \\ 1 \end{bmatrix} \quad B_I^{-1} = \begin{bmatrix} 1 & 0 \\ 0 & 1 \end{bmatrix} \quad b_j^* = \begin{bmatrix} 2X \\ 1 \end{bmatrix}$$

$$C_B = (0, 0) \quad C_R = \left[(1.321K), \begin{matrix} 1.321K \\ X \end{matrix}, X, (X+K), (X+K) \right]$$

$$R = \begin{matrix} & w_1 & w_2 & w_3 & w_4 & w_5 \\ \begin{bmatrix} 0 & 2 & 4 & 2 & 4 \\ 4 & 2 & 0 & 4 & 2 \end{bmatrix} \end{matrix}$$

This problem will be solved as a function of the X and K parameters to obtain general solution. However, a computer program (see Appendix B) was also written to provide a check to the analytical solution.

As we want to maximize, we need to find the values of X and K for which $(C_R - C_B B^{-1} R)$ is less than zero, this optimum of the dual will give

the optimum minimum of our initial problem, and $C_B B^{-1}$ will give the optimum values for M_a and M_b .

For analytical solutions go to paths (I), (II), (III).

For numerical computer solutions go to Appendix B and C.

Path (I)

$$1) \text{ Enter } W_2 \quad R_2 = \begin{bmatrix} 2 \\ 2 \end{bmatrix}$$

$$2) Y_2 = B^{-1} \begin{bmatrix} 2 \\ 2 \end{bmatrix} = \begin{bmatrix} 2 \\ 2 \end{bmatrix}$$

$$\text{Min } \left[\frac{2X}{2}, \frac{1}{2} \right] = \begin{cases} \text{For } X < 1/2 & i = 1, S_1 \text{ leaves} \\ \text{For } X > 1/2 & i = 2, S_2 \text{ leaves} \end{cases}$$

For $i = 1$ solution go to (IV).

$$3) X = 1/2 \quad B_{II}^{-1} = \begin{bmatrix} 1 & -1 \\ 0 & 1/2 \end{bmatrix} \quad A = \begin{array}{cc} S_1 & W_2 \\ \begin{bmatrix} 1 & 2 \\ 0 & 2 \end{bmatrix} \end{array}$$

$$4) b^* = B^{-1} \begin{bmatrix} 2X \\ 1 \end{bmatrix} = \begin{bmatrix} 2X - 1 \\ 1/2 \end{bmatrix} \quad R = \begin{array}{ccccc} W_1 & S_2 & W_3 & W_4 & W_5 \\ \begin{bmatrix} 0 & 0 & 4 & 2 & 4 \\ 4 & 1 & 0 & 4 & 2 \end{bmatrix} \end{array}$$

$$1) \text{ Enter } W_5 \quad R_5 = \begin{bmatrix} 4 \\ 2 \end{bmatrix}$$

$$2) Y_5 = B^{-1} R_5 = \begin{bmatrix} 2 \\ 1 \end{bmatrix}$$

$$\text{Min } \frac{2X-1}{2}, \frac{1/2}{1} = \begin{cases} \text{For } X < 1 & i = 1, S_1 \text{ Leaves} \\ \text{For } X > 1 & i = 2, W_2 \text{ leaves} \end{cases}$$

$$3) \quad 1/2 < X < 1$$

$$B_{III}^{-1} = \begin{bmatrix} 1/2 & -1/2 \\ -1/2 & 1 \end{bmatrix} \quad A = \begin{matrix} W_5 & W_2 \\ \begin{bmatrix} 4 & 2 \\ 2 & 2 \end{bmatrix} \end{matrix}$$

$$4) \quad R = \begin{matrix} W_1 & S_1 & W_3 & W_4 & S_2 \\ \begin{bmatrix} 0 & 1 & 4 & 2 & 0 \\ 4 & 0 & 0 & 4 & 1 \end{bmatrix} \end{matrix} \quad b^* = \begin{bmatrix} X & -3/4 \\ 1 & -X \end{bmatrix}$$

$$5) \quad C_B = \begin{bmatrix} X + K, & 1.321K \\ & X \end{bmatrix} \quad C_B^{-1} = \begin{bmatrix} 1/2(1.64K-X) & 1/2(X-.32K) \\ 1/2(S-K) & 1/2 K \end{bmatrix}$$

$$C_R = \begin{bmatrix} 1.321K, & 0 & , X & , K+X & , 0 \end{bmatrix}$$

$$C_B^{-1}R = \begin{bmatrix} 3.284K-X & .821K-1/2X, & 2X-.642K & 2.963K-X & 1/2X-.16K \\ 2(X-K) & , 1/2(X-K) & 2K & , 2X-K & , 1/2K \end{bmatrix}$$

$$C_R - C_B^{-1}R = \begin{bmatrix} 2X-1.963K & & .642K-X & 2X-1.983X \\ 3.321K-2X & & , X-2K & , 2K-X \end{bmatrix} < 0$$

If, a) $.642K < X < .981K$ and $1/2 < X < 1$

b) There is no optimum possible

$$6) \quad a) \quad S_1 = M_1 = 1/2(X-.32K)$$

$$S_2 = M_2 = 1/2(1.64K-X)$$

Collapse mechanisms b_i, e

$$1) \quad \text{Enter } W_3 \quad R_3 = \begin{bmatrix} 4 \\ 0 \end{bmatrix}$$

$$2) \quad Y_3 = B^{-1}R_3 = \begin{bmatrix} 2 \\ -2 \end{bmatrix}$$

$$Y_{23} = -2 < 0$$

Use $i = 1$

W_5 Leaves

Path (II.)

$$1) \text{ Enter } W_3 \quad R_3 = \begin{bmatrix} 4 \\ 0 \end{bmatrix}$$

$$2) Y_3 = B^{-1}R_3 = \begin{bmatrix} 4 \\ 0 \end{bmatrix}$$

$$Y_{23} = 0 \quad i = 1 \quad S_1 \text{ Leaves}$$

$$3) B_{II}^{-1} = \begin{bmatrix} 1/4 & 0 \\ 0 & 1 \end{bmatrix} \quad A = \begin{array}{cc} W_3 & S_2 \\ \begin{bmatrix} 4 & 0 \\ 0 & 1 \end{bmatrix} \end{array}$$

$$4) b^* = B_{II}^{-1}b = \begin{bmatrix} 1/4 & 0 & 2X & = & 1/2X \\ 0 & 1 & 1 & & 1 \end{bmatrix}$$

$$R = \begin{array}{ccccc} W_1 & W_2 & S_1 & W_3 & W_4 \\ \begin{bmatrix} 0 & 2 & 1 & 2 & 4 \\ 4 & 2 & 0 & 4 & 2 \end{bmatrix} \end{array}$$

$$1) \text{ Enter } W_5 \quad R_5 = \begin{bmatrix} 4 \\ 2 \end{bmatrix}$$

$$2) Y_5 = B^{-1}R_5 = \begin{bmatrix} 1 \\ 2 \end{bmatrix}$$

$$\text{Min} \left[\frac{1/2X}{1}, \frac{1}{2} \right] = \begin{array}{cc} X < 1 & i = 1 \\ X > 1 & i = 2 \end{array} \begin{array}{l} W_3 \text{ Leaves} \\ S_2 \text{ Leaves} \end{array}$$

$$3) X > 1$$

$$B_{III}^{-1} = \begin{bmatrix} 1/4 & -1/2 \\ 0 & 1/2 \end{bmatrix}$$

$$A = \begin{array}{cc} W_3 & W_5 \\ \begin{bmatrix} 4 & 4 \\ 0 & 2 \end{bmatrix} \end{array}$$

$$4) \quad R = \begin{matrix} & W_1 & W_2 & S_1 & W_4 & S_2 \\ \begin{matrix} 0 \\ 4 \end{matrix} & \begin{bmatrix} 0 & 2 & 1 & 2 & 0 \\ 4 & 2 & 0 & 4 & 1 \end{bmatrix} \end{matrix}$$

$$5) \quad C_B = [X, X + K] \quad C_B^{-1} = [1/4X, 1/2K]$$

$$C_R = \left[\begin{array}{cccccc} 1.321K, & 1.321K & , & 0 & , & K+X & , & 0 \end{array} \right]$$

$$C_B^{-1}R = \left[\begin{array}{cccccc} 2K & , & 1/2X+K & , & 1/4X, & 2K+1/2X, & 1/2K \end{array} \right]$$

$$C_R - C_B^{-1}R = \left[\begin{array}{cccccc} -.679K, & .321K-1/2X, & & , & 1/2X-K, & \end{array} \right] < 0$$

If, $.642K < X < 2K$ and $X > 1$

$$M_1 = 1/4X, \quad M_2 = 1/2K$$

Collapse mechanisms c, e

Path (III.)

$$1) \text{ Enter } W_y \quad R_4 = \begin{bmatrix} 2 \\ 4 \end{bmatrix}$$

$$2) \quad Y_4 = B^{-1} \begin{bmatrix} 2 \\ 4 \end{bmatrix} = \begin{bmatrix} 2 \\ 4 \end{bmatrix}$$

$$\text{Min } \left[\frac{2X}{2}, \frac{1}{4} \right] = \begin{bmatrix} \text{For } X < 1/4 & i = 1, S_1 \text{ Leaves} \\ \text{For } X > 1/4 & i = 2, S_2 \text{ Leaves} \end{bmatrix}$$

$$3) \quad X > 1/4 \quad B_{II}^{-1} = \begin{bmatrix} 1 & -1/2 \\ 0 & 1/4 \end{bmatrix} \quad A = \begin{array}{cc} S_1 & W_4 \\ \begin{bmatrix} 1 & 2 \\ 0 & 4 \end{bmatrix} \end{array}$$

$$4) \quad b^* = B^{-1} \begin{bmatrix} 2X \\ 1 \end{bmatrix} = \begin{bmatrix} 2X-1/2 \\ 1/4 \end{bmatrix} \quad R = \begin{array}{ccccc} W_1 & W_2 & W_3 & S_2 & W_5 \\ \begin{bmatrix} 0 & 2 & 4 & 0 & 4 \\ 4 & 2 & 0 & 1 & 2 \end{bmatrix} \end{array}$$

To enter W_2 go to (V).

$$1) \text{ Enter } W_5 \quad R_5 = \begin{bmatrix} 4 \\ 2 \end{bmatrix}$$

$$2) \quad Y_5 = B^{-1} R_5 = \begin{bmatrix} 3 \\ 1/2 \end{bmatrix}$$

$$\text{Min } \left[\frac{2X-1/2}{3}, \frac{1/4}{1/2} \right] = \begin{bmatrix} X < 1 & i = 1 & S_1 \text{ Leaves} \\ X > 1 & i = 2 & W_4 \text{ Leaves} \end{bmatrix}$$

$$3) \quad 1/4 < X < 1 \quad B^{-1} = \begin{bmatrix} 1/3 & -1/6 \\ -1/6 & 1/3 \end{bmatrix} \quad A = \begin{array}{cc} W_5 & W_4 \\ \begin{bmatrix} 4 & 2 \\ 2 & 4 \end{bmatrix} \end{array}$$

$$4) \quad R = \begin{matrix} & W_1 & W_2 & W_3 & S_2 & S_1 \\ \begin{matrix} 0 \\ 4 \end{matrix} & \begin{bmatrix} 0 & 2 & 4 \\ 4 & 4 & 0 \end{bmatrix} & \begin{matrix} 0 \\ 1 \end{matrix} & \begin{matrix} 0 \\ 0 \end{matrix} & \begin{matrix} 1 \\ 0 \end{matrix} \end{matrix}$$

$$5) \quad C_B = [X+K, X+K] \quad C_B B^{-1} = [1/6(X+K), 1/6(S+K)]$$

$$\begin{aligned} C_R &= [1.321K, 1.321K, X, 0, 0] \\ C_B B^{-1} R &= [2/3(X+K), 2/3(X+K), 2/3(X+K), 1/6(X+K), 1/6(X+K)] \\ C_R - C_B B^{-1} R &= [.654K - 2/3X, .654K - 2/3X, 1/3X - 2/3K, \dots] < 0 \end{aligned}$$

If, $.981K < X < 2K$ and $1/4 < X < 1$

$$M_1 = M_2 = 1/6(X+K)$$

Collapse mechanisms d, e

Path (IV)

3) $x < 1/2$

$$B_{II}^{-1} = \begin{bmatrix} 1/2 & 0 \\ -1 & 1 \end{bmatrix}$$

$$A = \begin{array}{cc} W_2 & S_2 \\ \begin{bmatrix} 2 & 0 \\ 2 & 1 \end{bmatrix} \end{array}$$

4) $b^* = B^{-1} \begin{bmatrix} 2X \\ 1 \end{bmatrix} = \begin{bmatrix} X \\ 1-2X \end{bmatrix}$

$$R = \begin{array}{ccccc} W_1 & S_1 & W_3 & W_4 & W_5 \\ \begin{bmatrix} 0 & 1 & 4 & 2 & 4 \\ 4 & 0 & 0 & 4 & 2 \end{bmatrix} \end{array}$$

1) Enter W_1 $R_1 = \begin{bmatrix} 0 \\ 4 \end{bmatrix}$

2) $Y_1 = B^{-1}R_1 = \begin{bmatrix} 0 \\ 4 \end{bmatrix}$

$Y_{11} = 0$ use $Y_{21} = 4$ $i = 2$, S_2 Leaves

3) $x < 1/2$

$$B_{III}^{-1} = \begin{bmatrix} 1/4 & 0 \\ -1/4 & 1/4 \end{bmatrix}$$

$$A = \begin{array}{cc} W_2 & W_1 \\ \begin{bmatrix} 2 & 0 \\ 2 & 4 \end{bmatrix} \end{array}$$

4) $b^* = \begin{bmatrix} 1/2X \\ 1/4-3/4X \end{bmatrix}$

$$R = \begin{array}{ccccc} S_2 & S_1 & W_3 & W_4 & W_5 \\ \begin{bmatrix} 0 & 1 & 4 & 2 & 4 \\ 1 & 0 & 0 & 4 & 2 \end{bmatrix} \end{array}$$

5) $C_B = \begin{bmatrix} 1.321K & 1.321K \\ X & \end{bmatrix}$

$$C_B^{-1} = \begin{bmatrix} .33K & .33K \\ 1/2X-.33K & \end{bmatrix}$$

$$C_R = \begin{bmatrix} 0 & , & 0 & , & X & , & X+K & , & X+K \end{bmatrix}$$

$$C_B B^{-1} R = \begin{bmatrix} .33K, & .33K & 1.321K & 1.981K & 1.981K \\ & 1/2X-.33K & 2X-1.321K & X+.66K & 2X-.66K \end{bmatrix}$$

$$C_R - C_B B^{-1} R = \begin{bmatrix} , & , & X-1.321K & X-.981K & X-.981K \\ & & 1.321K-X & +.34K & .34K-X \end{bmatrix} < 0$$

If, a) $X < .981K$ and $X < 1/2$

$$M_1 = M_2 = .33K$$

Collapse mechanisms a_1, b_1

$$1) \text{ Enter } W_4 \quad R_4 = \begin{bmatrix} 2 \\ 4 \end{bmatrix}$$

$$2) \quad Y_4 = B^{-1} R_4 = \begin{bmatrix} 1 \\ 1/2 \end{bmatrix}$$

$$\text{Min} \left[\frac{1/2X}{1}, \frac{1/4 - 3/4X}{1/2} \right] = \begin{bmatrix} \text{For } X < 1/4 & i = 1, W_2 \text{ Leaves} \\ \text{For } X > 1/4 & i = 2, W_1 \text{ Leaves} \end{bmatrix}$$

3) $X < 1/4$

$$B_{IV}^{-1} = \begin{bmatrix} 1/2 & 0 \\ -1/2 & 1/4 \end{bmatrix}$$

$$A = \begin{bmatrix} W_4 & W_1 \\ 2 & 0 \\ 2 & 4 \end{bmatrix}$$

4)

$$R = \begin{bmatrix} S_2 & S_1 & W_3 & W_2 & W_5 \\ 0 & 1 & 4 & 2 & 4 \\ 1 & 0 & 0 & 2 & 2 \end{bmatrix}$$

$$5) \quad C_B = \begin{bmatrix} X + K, & 1.321K \end{bmatrix}$$

$$C_B B^{-1} = \begin{bmatrix} 1/2(X-.321K), & .33K \end{bmatrix}$$

$$C_R = \begin{bmatrix} 0 & , & 0 & , & X & , & 1.321K & , & X + K \\ & & & & & & K & & \end{bmatrix}$$

$$C_B^{-1} C_R = \begin{bmatrix} .33K, & 1/2(X-.321K), & 2X-.642K, & X+.339K, & 2X+.018K \end{bmatrix}$$

$$C_R - C_B^{-1} C_R = \begin{bmatrix} , & , & .642K-X, & .981K-X, & .981K-X \\ & & & -.339K, & \end{bmatrix} < 0$$

If, $X < .982K$ and $X < 1/4$

$$M_1 = 1/2(X-.321K) \quad M_2 = .33K$$

Collapse mechanisms a_1, d

Path (V)

$$1) \text{ Enter } W_2 \quad R_2 \begin{bmatrix} 2 \\ 2 \end{bmatrix}$$

$$2) Y_2 = B_{II}^{-1} R_2 = \begin{bmatrix} 1 \\ 1/2 \end{bmatrix}$$

$$\text{Min} \left[\frac{2X-1/2}{1}, \frac{1/4}{1/2} \right] = \begin{bmatrix} X < 1/2 & i = 1 & S_1 \text{ Leaves} \\ X > 1/2 & i = 2 & W_4^1 \text{ Leaves} \end{bmatrix}$$

$$3) 1/4 < X < 1/2$$

$$B_{III}^{-1} = \begin{bmatrix} 1 & -1/2 \\ -1/2 & 1/2 \end{bmatrix}$$

$$A = \begin{matrix} W_2 & W_4 \\ \begin{bmatrix} 2 & 2 \\ 2 & 4 \end{bmatrix} \end{matrix}$$

$$4) R = \begin{matrix} W_1 & S_1 & W_3 & S_2 & W_5 \\ \begin{bmatrix} 0 & 1 & 4 & 0 & 4 \\ 4 & 0 & 0 & 1 & 2 \end{bmatrix} \end{matrix}$$

$$5) C_B = \begin{bmatrix} 1.321K & X + K \\ K & \end{bmatrix}$$

$$C_B B^{-1} = \begin{bmatrix} 1/2(1.642K-X) & 1/2(X-321K) \\ 1/2(X-K) & 1/2K \end{bmatrix}$$

$$C_R = \begin{bmatrix} 1.321K & 0 & X & 0 \end{bmatrix}$$

$$C_B B^{-1} R = \begin{bmatrix} 2X - .64K & 1/2(1.642K-X) & 3.284K-2X & 1/2(X-321K) & 2963K-X \\ 2K & 1/2(X-K) & 2X-2K & 1/2K & 2X-K \end{bmatrix}$$

$$C_R - C_B B^{-1} R = \begin{bmatrix} 1.961K-2X & & 3X-3.284K & & -1.963K \\ -.689 & & 2X-X & & 2K-X \end{bmatrix} < 0$$

If, a) There is no optimum possible

b) $X > 2K$ and $1/4 < X < 1/2$

$$M_1 = 1/2(X-K), \quad M_2 = 1/2K$$

Collapse mechanisms b^1, d

The optimum solutions that provide the collapse mechanisms and optimum moments for different values of X and K are presented below and also in Graph No. I.

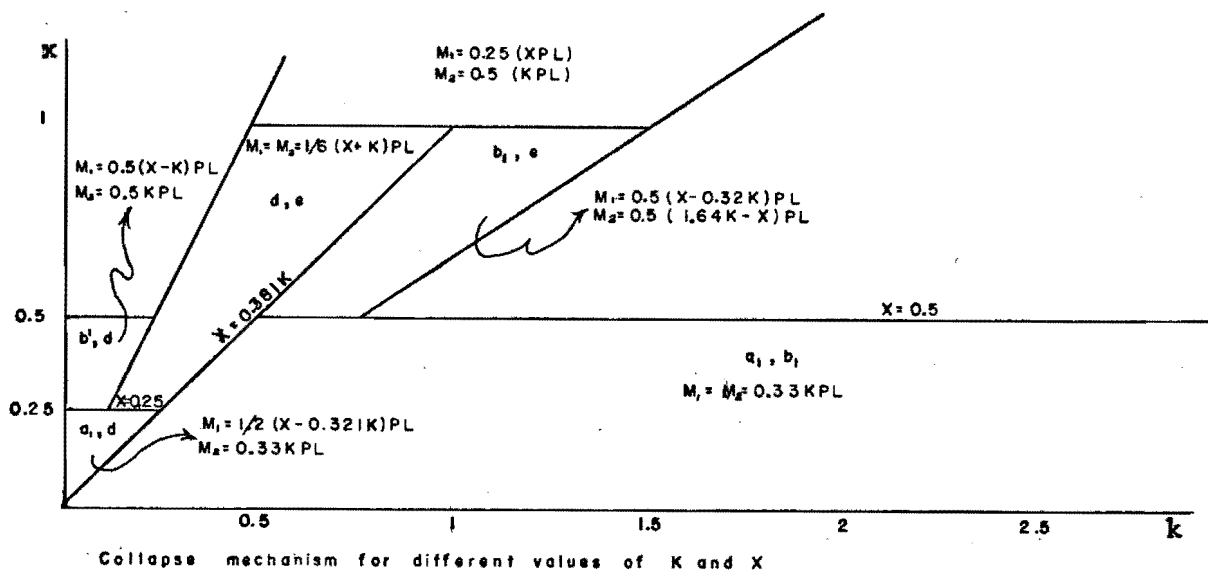

IV. 4. Example: Design the frame shown in Fig. 4.5.

$$f = 1.4 \quad P = (13) (1.4) = 18.2 \text{ kips}$$

$$X = \frac{h}{L} = \frac{24}{32} = .75 \quad K = \frac{26}{(2)(13)} = 1$$

From Graph I at $X = .75$ and $K = 1$ the collapse mechanisms are b_1 and e ; the moments are:

$$M_1 = 1/2(X - .321K)PL = .215PL = 125.2 \text{ kips-ft.}$$

$$M_2 = 1/2(1.642K - X)PL = .446PL = 259.6 \text{ kips ft.}$$

The bending moment diagrams are shown in Fig. No. 4.6. There are two collapse mechanisms; b_1 for the gravity loads, and e for the combined loads, these mechanisms provide the basis for the design requirements.

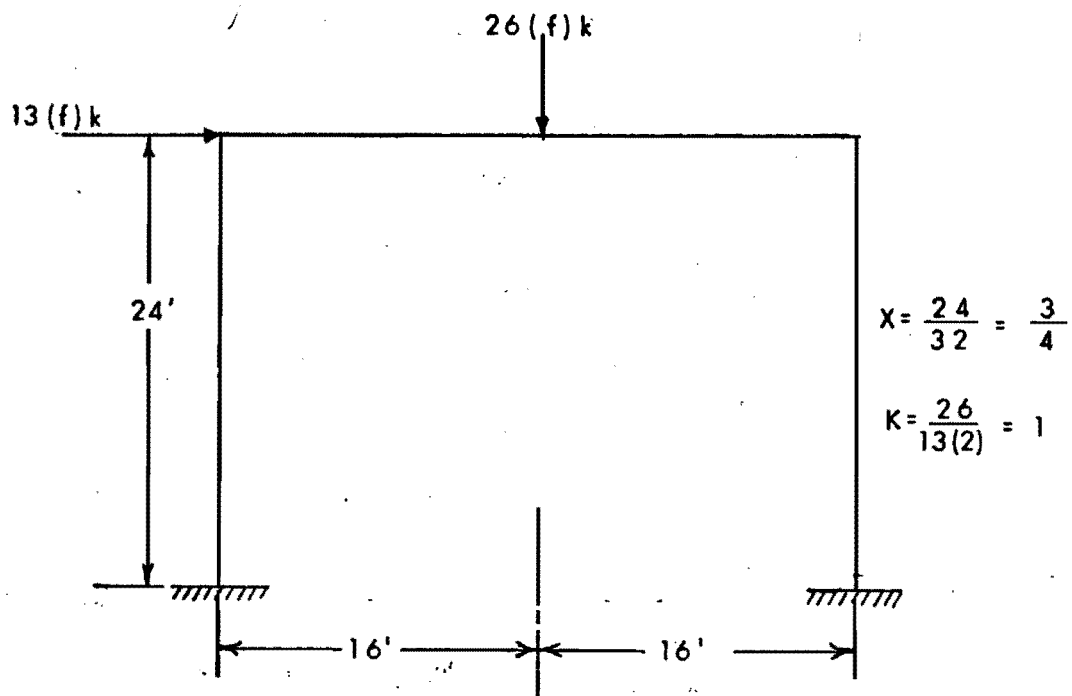

FIG. 4.5 FIXED-ENDED RECTANGULAR FRAME

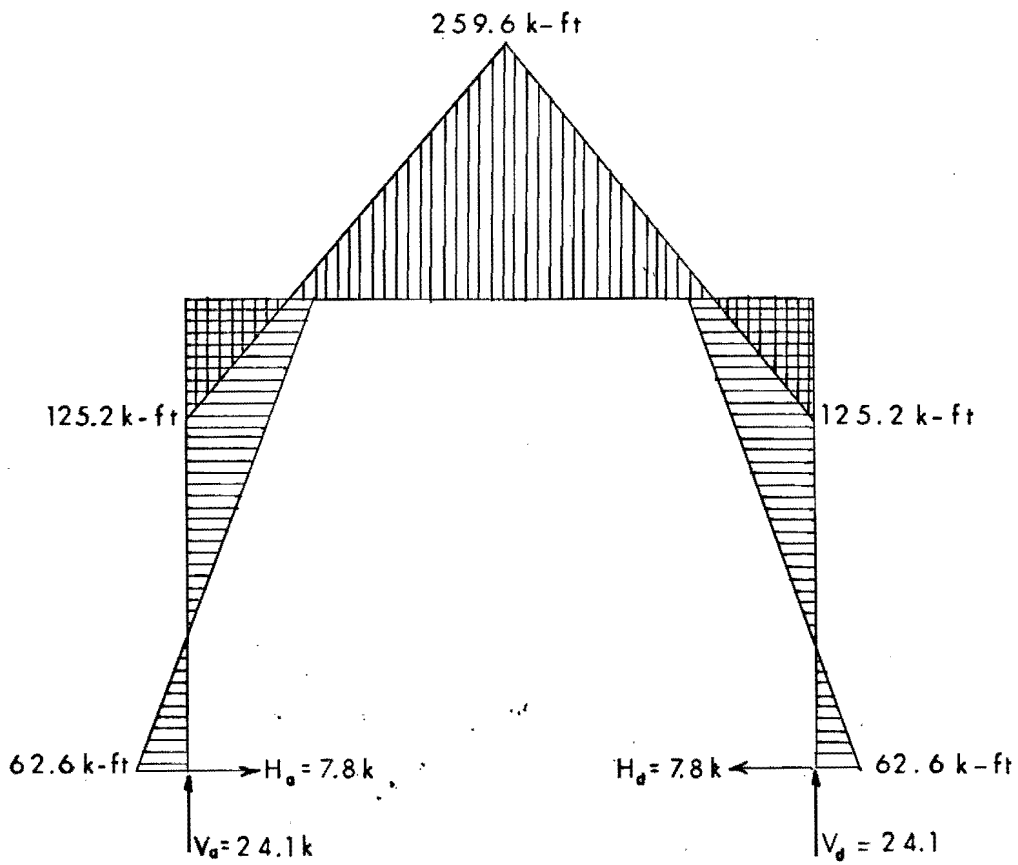

FIG. 4.6a MOMENT DIAGRAM FOR "b" (gravity loads)

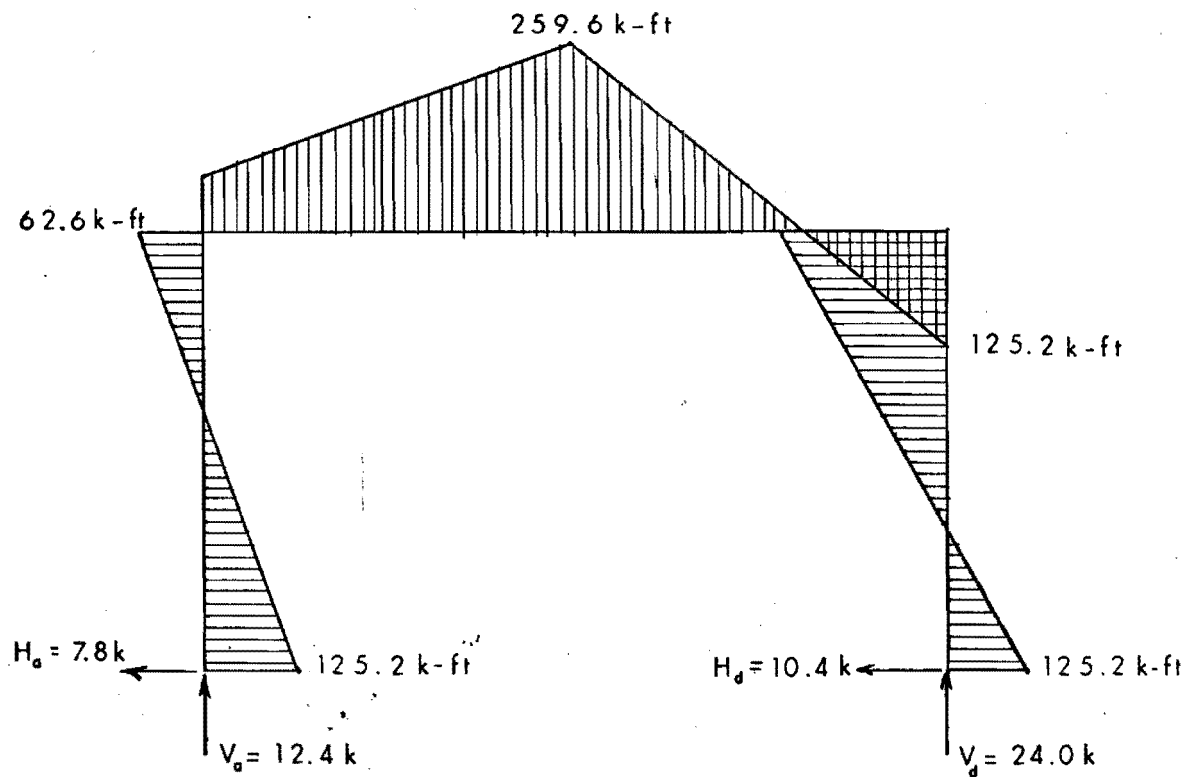

FIG. 4.6b MOMENT DIAGRAM FOR "e" (combined loading)

Taking the higher values for plastic moments, shear and normal stresses we have:

$$M_1 = 125.2 \text{ K-ft.}$$

$$M_2 = 259.6 \text{ K-ft.}$$

$$V_{cd} = H_d = 10.4 \text{ K}$$

$$N_{ab} = V_a = N_{cd} = V_d = 24.1 \text{ K}$$

$$N_{bc} = 10.4 \text{ K}$$

Choice of Section

$$\text{Column } M_1 = 125.2 \text{ k-ft.}$$

$$Z_1 = \frac{125.2 \times 12}{36} = 41.73 \text{ in.}^3$$

12 WF31

$$Z_1 = 44.0 \text{ in.}^3$$

$$A = 9.12 \text{ in.}^2$$

$$b = 6.525 \text{ in.}^2$$

$$d = 12.09 \text{ in.}$$

$$t = .465 \text{ in.}$$

$$w = .265$$

$$r_x = 5.11 \text{ in.}$$

$$r_y = 1.47 \text{ in.}$$

Beam

$$M_2 = 259.6 \text{ k-ft.}$$

$$Z_2 = \frac{259.6 \times 12}{36} = 86.53 \text{ in.}^3 \quad \frac{259.6 \times 12}{36} = \underline{86.53 \text{ in.}^3}$$

18 WF 45

$Z = 89.6 \text{ in.}$

$A = 13.24 \text{ in.}^2$

$b = 7.477 \text{ in.}$

$d = 17.86 \text{ in.}$

$t = .499 \text{ in.}$

$w = .335 \text{ in.}$

$r_x = 7.30 \text{ in.}$

$r_y = 1.55 \text{ in.}$

Shear Force*

$$V_{ab} = 10.4 < .550 \sigma_y w d \times 10^{-3}$$

$$< .55 \times 36 \times .265 \times 9.12 = 48.2 \text{ k}$$

$$V_b = 24.1 < .55 \times 36 \times .395 \times 17.86$$

Normal Force

$$P_y = A \sigma_y = 9.12 \times 36 = 328 \text{ k}$$

Stability Check

$$2 \frac{N_p}{P_y} + \frac{1}{70} \frac{L}{r_x} \leq 1$$

$$2 \left[\frac{24.1}{328} \right] + \frac{1}{70} \left[\frac{24 \times 12}{5.11} \right] = .147 + .806 < 1 \quad \text{O.K.}$$

Buckling Strength

$$\frac{M_d}{P_y} = \frac{24.1}{328} = .0735 < .15$$

The full plastic moment of section may be used.

* Designed according to Ref. 8

Cross Section Proportions

Beam	Column
$b/t = 12.6$	$15.5 < 17$ OK
$d/w = 53.3$	$45.6 < 70-100 \frac{N_P}{P_y} = 62.7$ OK

Lateral Bracing

$$\text{Columns } l_{cr} = (60-40 \frac{M}{M_P}) r_y = 60-40(-1) \times 1.47 = 147.0 \text{ in.}$$

$147.0 < 24 \times 12 = 288$ One lateral support is necessary.

Brace Column at $12' = 144$ in. from top.

Brace beam at $4' < 35 r_y$, intervals.

Connections

$$W_d = W_r - W = \frac{3 M_P}{\sigma_y d_b d_c} - W$$

$$W_d = \frac{3 \times 125.2 \times 12}{36 \times 13.24 \times .12} - .335 = .598 - .381 = .267 \text{ in.}$$

Use two double plates of at least .134 in. thickness each.

IV. 5. Concluding Remarks. Graph No. 1 provides a way to obtain directly the optimum design moments of a single-bay, single-story, fixed-ended portal frame. The amount of computation involved in developing this type of graph depends significantly on the number of variables in the primal, that is, the required M_{pi} (M_1 and M_2 here-in). This is true because it is the dual of the problem that is the one solved, and the order of the transformation matrix B^{-1} depends on the number of the original variables. The two collapse mechanisms obtained in the example were related to different loading conditions; therefore, both distributions of moments should be analysed.

V. STUDY OF A ONE-BAY ONE-STORY HINGED-ENDED PORTAL FRAME

V. 1. Introduction. This chapter follows the general outline of Chapter IV with the difference that the solution to the linear programming problem is obtained semigraphically. A design aid (Graph No. 2) will be developed and a design example will be provided.

V. 2. One-Bay, One-Story, Hinged-Ended Portal Frame. Consider the frame shown in Fig. 5.1 where both columns have the same plastic moment, M_1 , which may differ from M_2 , the plastic moment of the beam. There are five potentially critical sections, the redundancy is $4-3=1$. Thus, the number of basic mechanisms is $5-1=4$. The four independent mechanisms are shown in Fig. 5.2; these are: the beam mechanism, the panel mechanism and two false mechanisms of the rotation of the joints. All possible mechanisms and their work equations are shown in Fig. 5.3.

The objective function is the same as the one for the fixed ended, portal frame (Chapter IV.), that is:

$$B = \frac{2XM_1}{PL} + \frac{M_2}{PL}$$

For a combined loading the linear constraints related to these mechanisms are:

$$(a) \quad \frac{4M_2}{PL} > K$$

$$(b) \quad \frac{2M_1}{PL} + \frac{2M_2}{PL} > K$$

$$(c) \quad \frac{2M_2}{PL} > X$$

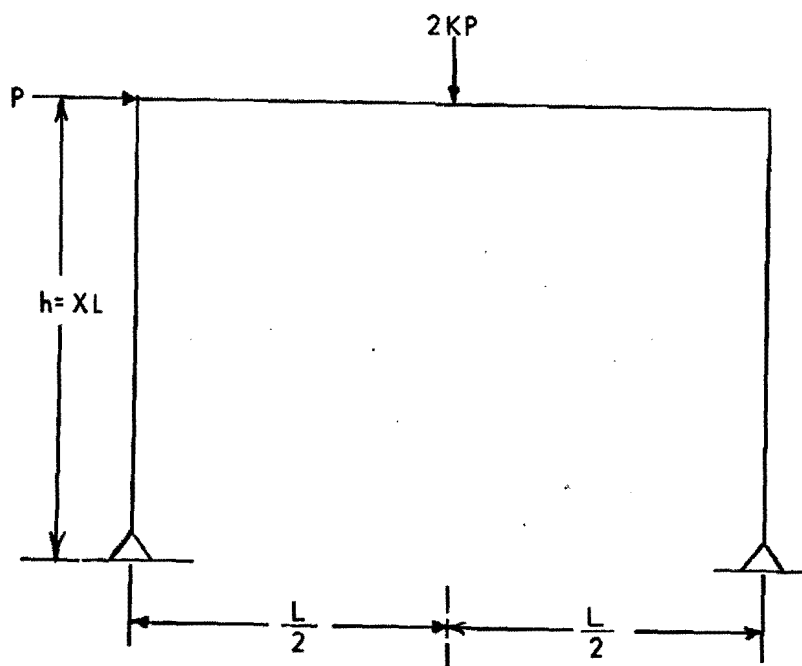
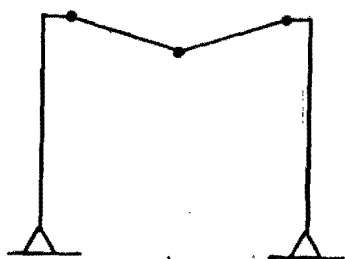
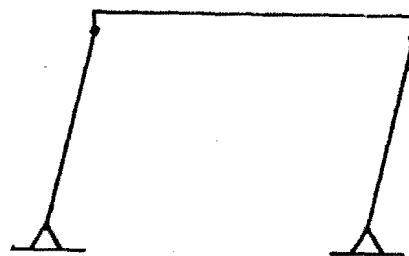

FIG. 5.1 HINGED ENDS RECTANGULAR FRAME



BEAM MECHANISM



PANEL MECHANISM



JOINT MECHANISMS

FIG. 5.2 BASIC MECHANISMS

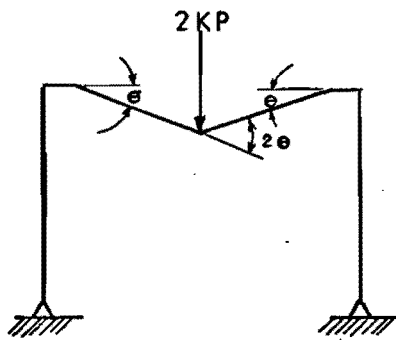

(a) $4M_2 \leq KPL$

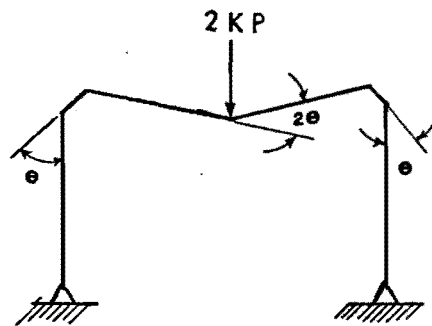

(b) $2M_1 + 2M_2 \leq KPL$

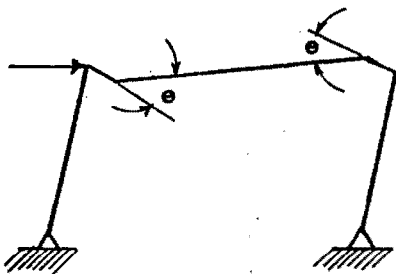

(c) $2M_2 \leq XPL$

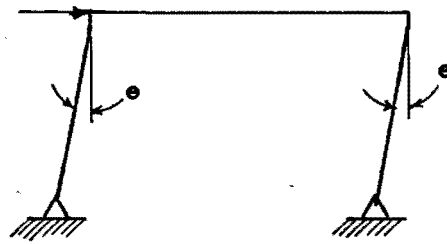

(d) $2M_1 \leq XPL$

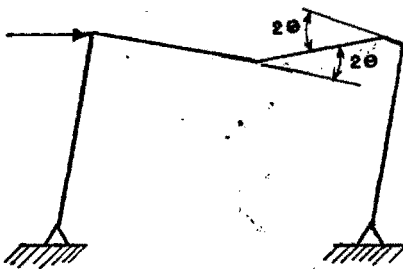

(e) $4M_2 \leq (X + K)PL$

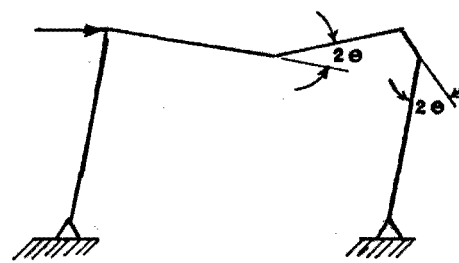

(f) $2M_1 + 2M_2 \leq (X + K)PL$

FIG. 5.3 COLLAPSE MECHANISMS

$$(d) \quad 2 \frac{M_1}{PL} \geq X$$

$$(e) \quad 4 \frac{M_2}{PL} \geq X + K$$

$$(f) \quad 2 \frac{M_1}{PL} + 2 \frac{M_2}{PL} \geq X + K$$

$$\frac{M_1}{PL} \geq 0, \quad \frac{M_2}{PL} \geq 0$$

The gravity loading constraints are the same as the ones in part IV, that is:

$$(a_1) \quad 4 \frac{M_2}{PL} \geq 1.321K$$

$$(b_1) \quad 2 \frac{M_1}{PL} + 2 \frac{M_2}{PL} \geq 1.321K$$

V. 3. The Linear Programming Problem.

Combining both sets of constraints as in part IV and eliminating

(a) and (b) we have:

$$\text{Minimize } B = 2X \frac{M_1}{PL} + \frac{M_2}{PL}$$

S.t.

$$(a_1) \quad 4 \frac{M_2}{PL} \geq 1.321K$$

$$(b_1) \quad 2 \frac{M_1}{PL} + 2 \frac{M_2}{PL} \geq 1.321K$$

$$(c) \quad 2 \frac{M_2}{PL} \geq X$$

$$(d) \quad 2 \frac{M_1}{PL} \geq X$$

$$(e) \quad 4 \frac{M_2}{PL} \geq X + K$$

$$(f) \quad 2 \frac{M_1}{PL} + 2 \frac{M_2}{PL} \geq X + K$$

A graphical solution of this linear programming problem will give
(see Fig. 5.4):

(I) For $X > K$

$$M_1 = M_2 = \frac{X}{2} PL$$

Collapse Mechanisms c, d

(II) For $.321K < X < K$

(a) $X < .5$

$$M_1 = M_2 = 1/4 (X + K) PL$$

Collapse Mechanisms e, f

(b) $X > .5$

$$M_1 = \frac{X}{2} PL \quad M_2 = \frac{K}{2} PL$$

Collapse Mechanisms d, f

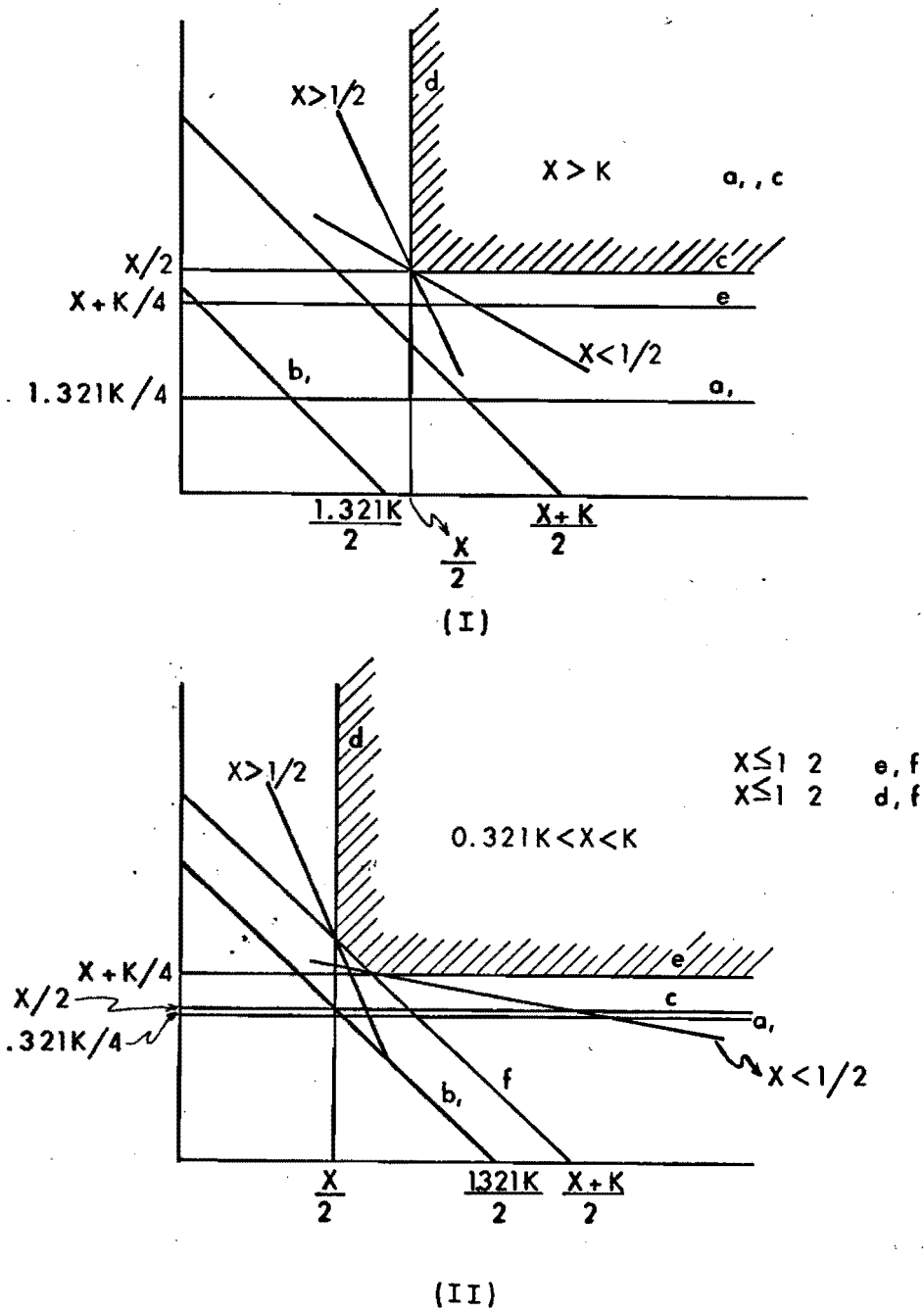
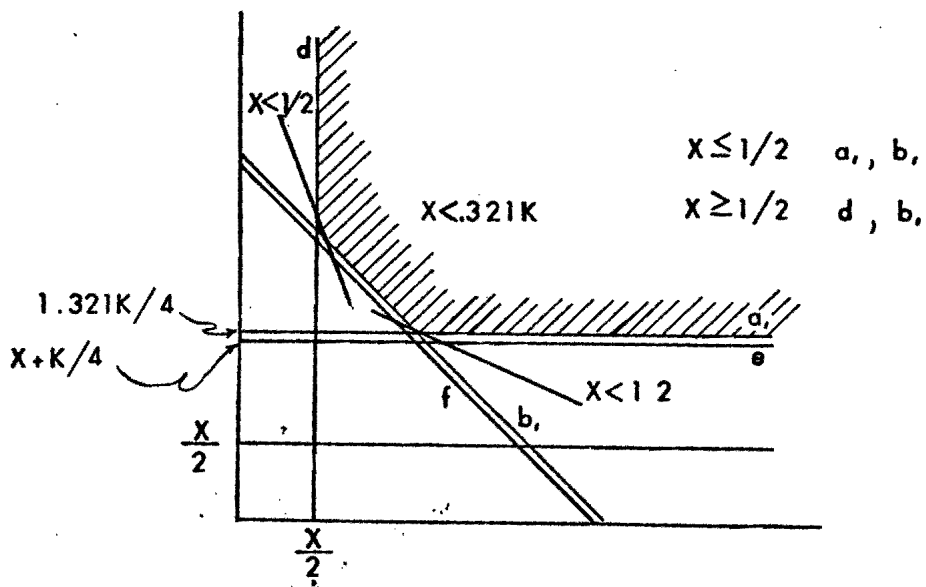

FIG. 5.4 (A)



(III)

FIG. 5.4 (B)

(III) For $X < .321 K$

(a) $X < .5$

$$M_1 = M_2 = .33KPL$$

Collapse Mechanisms a_1, b_1

(b) $X > .5$

$$M_1 = \frac{X}{2} PL \quad M_2 = 1/2 (1.321K-X)$$

Collapse Mechanisms b_1, d

The optimum solutions that provide the collapse mechanisms and optimum moments for different values of X and K are presented in Graph No. II.

V. 4. Example: Design the frame for the load shown in Fig. 5.5.

$$f = 1.4 \quad P = 13 \times 1.4 = 18.2$$

$$X = 3/4 \quad K = 1$$

$$.321K < X < K \quad X > 1/2$$

From Graph II at $X = .75$ and $K = 1$ the collapse mechanisms are d and f , and the moments are:

$$M_1 = 1/2 X PL = (1/2) (3/4) \times 18.2 \times 32 = 218.4 \text{ K-ft.}$$

$$M_2 = 1/2 KPL = (1/2) \times 1 \times 18.2 \times 32 = 291.2 \text{ K-ft.}$$

Collapse Mechanisms are d, f

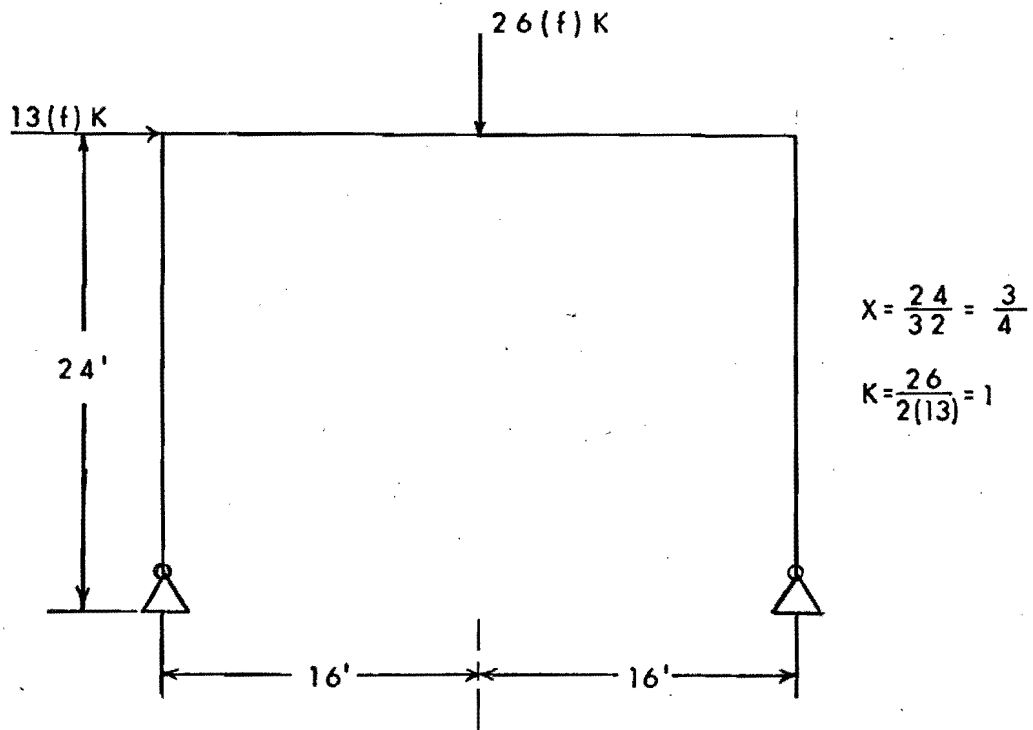

FIG. 5.5 HINGED ENDS RECTANGULAR FRAME

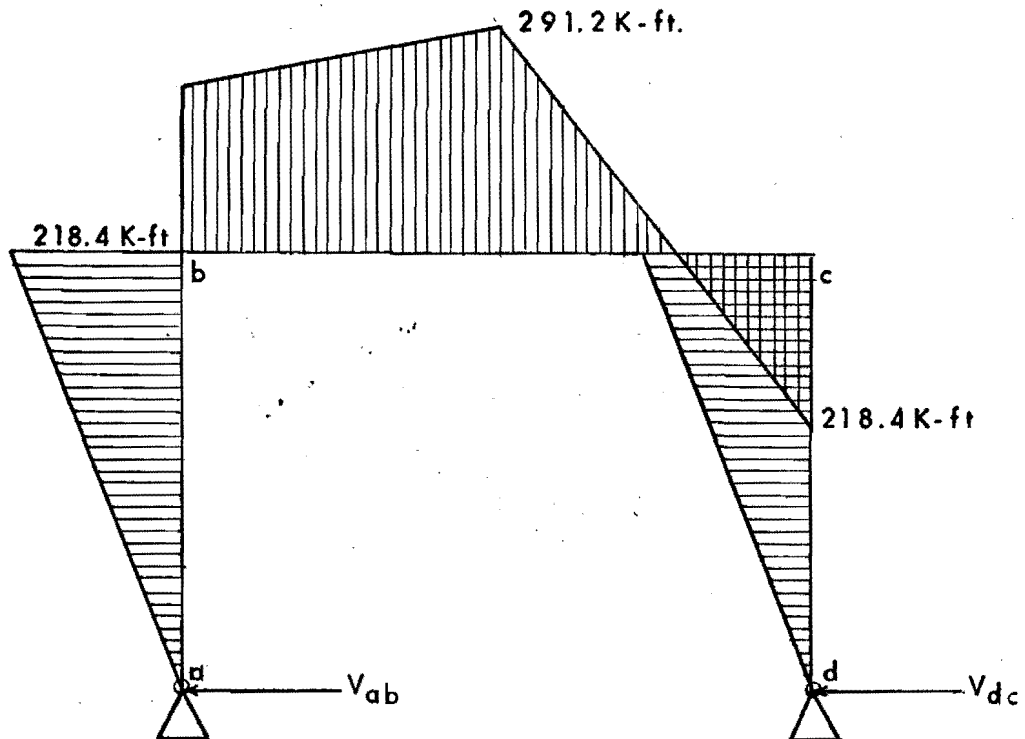

FIG. 5.6 MOMENT DIAGRAM

Analysis:

The moment diagram is shown in Fig. 5.6; from there:

$$V_{dc} = \frac{M_1}{h} = \frac{218.4}{24} = 9.1K$$

$$V_{ab} = 18.2 - 9.1 = 9.1K$$

$$N_{dc} = \frac{18.2 \times 24 + 36.4 \times 16}{32} = 31.85K = -V_c$$

$$N_{ab} = 4.55K = V_b$$

Choice of Section

Columns

$$M_1 = 218.4 \text{ k-ft.}$$

$$Z = \frac{218.4 \times 12}{36} = 72.8 \text{ in.}^3$$

14 WF 48

$$Z = 78.5 \text{ in.}^3$$

$$A = 14.11 \text{ in.}^2$$

$$d = 13.81 \text{ in.}$$

$$b = 8.031 \text{ in.}$$

$$t = .593 \text{ in.}$$

$$w = .339 \text{ in.}$$

$$r_x = 5.86 \text{ in.}$$

$$r_y = 1.91 \text{ in.}$$

Beam

$$M_1 = 291.2 \text{ K-ft.}$$

$$Z = \frac{291.2 \times 12}{36} = 97.1 \text{ in.}^3$$

18 WF 50

$$Z = 100.8 \text{ in.}^3$$

$$A = 14.71 \text{ in.}^2$$

$$d = 18.0 \text{ in.}$$

$$b = 7.5 \text{ in.}$$

$$t = .570 \text{ in.}$$

$$w = .358 \text{ in.}$$

$$r_x = 7.38 \text{ in.}$$

$$r_y = 1.59 \text{ in.}$$

Shear Force

$$V_{ab} = 9.1 < .55 \sigma_y w d = .55 \times 36 \times .339 \times 13.81 = 93 \text{ K OK}$$

$$V_c = 31.85 < 19.8 \times .358 \times 18 = 127.6 \text{ K OK}$$

Normal Force

$$P_y = A \sigma_y = 14.11 \times 36 = 508 \text{ K}$$

Stability Check

$$2 \left[\frac{N_p}{P_y} \right] + \frac{1}{70} \left[\frac{L}{r_x} \right] \leq 1$$

$$2 \left[\frac{31.85}{508} \right] + \frac{1}{70} \left[\frac{24 \times 12}{5.86} \right] = .125 + .701 < 1 \text{ OK}$$

Buckling Strength

$$\frac{N_p}{P_y} = \frac{31.85}{508} = .0625 < .15$$

The full plastic moment of section may be used.

Cross Section Proportions

	Beam	Column	
b/t =	13.2	13.5	< 17 OK
d/w =	50.3	40.7	< 55 OK

Lateral Bracing

$$\text{Columns } l_{cr} = (60 - 40 \frac{M}{M_p}) r_y = 60 \times 1.91 = 114.6 \text{ in.}$$

114.6 < 24 x 12 = 288 in. Lateral support is necessary.

Brace columns at 35 r_y = 67 in. from top and 110 in. from bottom.

Brace Beam at 55 in. < 35 r_y intervals.

Connections

$$w_d = w_r - w_b = \frac{3 M_p}{\sigma_y d_b d_c} - w_b = \frac{3 \times 218.4 \times 12}{36 \times 18 \times 13.81} - .358$$

$$= .508 - .358 = .150$$

Use two double plates of at least .075 in. thickness each.

V. 5. Concluding Remarks. The use of the semigraphical method of solution to linear programming is limited to special cases of problems which contain no more than two variables; hence, its use in this chapter. The two collapse mechanisms obtained in the design example are related to the same loading condition. Therefore, a new mechanism is formed with plastic hinges common to the original two. This new collapse mechanism is called Foulkes mechanism; it has the characteristic that the slope of its energy equation is parallel to the minimum weight objective function.

VI. SUMMARY AND CONCLUSIONS

VI. 1. Summary. Based on the concepts of minimum weight, plastic theory and linear programming, the general solution graphs developed in this paper provide the values of the plastic moments as well as the corresponding collapse mechanisms for different loading conditions and dimensions of a single-bay, single-story portal frame.

It should be pointed out that the regular plastic design procedure starts with a preliminary design and then determines the corresponding collapse mechanism under each loading condition, then the collapse loads are compared with the working loads. If the design is to be changed the new collapse mechanisms must be found again, etc. The determination of the collapse mechanisms requires a good deal of effort and skill on the part of the designer. In contrast, from the graphs 1 and 2, developed in Chapter IV and Chapter V, we could obtain directly the collapse mechanisms. In the case where each of the two collapse mechanisms are related to different loading conditions (as in the example in Chapter IV), the two mechanisms should be analyzed to obtain a feasible design. In the case where both collapse mechanisms are related to the same loading conditions, (as in the example in Chapter V), a new mechanism is formed with plastic hinges common to the original two. This new collapse mechanism is formed with plastic hinges common to the original two. This new collapse mechanism is called Foulkes mechanism¹ and has the characteristic that the slope of its energy equation is the same as the slope of the minimum weight objective function.

The practical use of the general solutions to the plastic design is twofold; one is in the graphical form as a design aid, and two, with the help of a computer, the general solution and other pertinent information

may be stored to provide a direct design of single-bay, single-story portal frames.

VI. 2. Conclusions. From this study the following conclusions may be drawn:

1. The integration of both gravity and combined loading into one linear programming problem has been shown to be feasible, and the solution thus obtained satisfies both loading conditions.

2. The application of the revised simplex method to the dual of a parametric primal problem provides a useful technique for the development of general solutions to optimum design problems. This has been illustrated in Chapter IV to obtain Graph No. 1.

3. The amount of computation involved in the development of this type of solutions (conclusion No. 2) depends mainly on the number of variables of the primal problem, and to a much lesser degree on the number of parameters.

4. Graphs 1 and 2, presented in Appendix C, greatly simplify the design of single-bay, single-story portal frames by providing moment requirements for optimum designed frames. To use these graphs (design aids), a designer need not know linear programming or computers.

Appendix A

Linear Programming - Revised Simplex ⁹

The "general linear programming problem" seeks a vector

$X = (x_1, x_2, \dots, x_n)$ which will:

Maximize

$$c_1 x_1 + c_2 x_2 + \dots + c_j x_j + \dots + c_n x_n$$

Subject to

$$x_j \geq 0, \quad j = 1, 2, \dots, n$$

$$a_{11} x_1 + a_{12} x_2 + \dots + a_{1j} x_j + \dots + a_{1n} x_n \leq b_1$$

$$a_{21} x_1 + a_{22} x_2 + \dots + a_{2j} x_j + \dots + a_{2n} x_n \leq b_2$$

...

$$a_{i1} x_1 + a_{i2} x_2 + \dots + a_{ij} x_j + \dots + a_{in} x_n \leq b_i$$

$$a_{m1} x_1 + a_{m2} x_2 + \dots + a_{mj} x_j + \dots + a_{mn} x_n \leq b_m$$

where a_{ij} , b_i , c_j are specified constants, $m < n$, and $b_i \geq 0$.

Alternately, the "constraint equations," may be written in matrix

form:

$$\begin{bmatrix} a_{11} & a_{12} & \dots & a_{1n} \\ a_{21} & a_{22} & \dots & a_{2n} \\ \dots & \dots & \dots & \dots \\ a_{m1} & a_{m2} & \dots & a_{mn} \end{bmatrix} \begin{bmatrix} x_1 \\ x_2 \\ \dots \\ x_n \end{bmatrix} \leq \begin{bmatrix} b_1 \\ b_2 \\ \dots \\ b_m \end{bmatrix}$$

or,

$$AX \leq \vec{b}$$

$$x_j \geq 0$$

Thus the linear programming problem may be stated as:

$$\begin{array}{ll} \text{Maximize} & \bar{c}\bar{x} \\ \text{S.t.} & A\bar{x} \leq \bar{b} \\ & x_j \geq 0 \quad j = 1, 2, \dots, n \end{array}$$

In contrast with the simplex method that transforms the set of numerical values in the simplex tableau. The revised simplex reconstructs completely the tableau at each iteration from the initial data, A , b or c (or equivalently, from the first simplex tableau) and from the inverse B^{-1} of the current basis B .

We start with a Basis $B^{-1} = I$ and $R = A$, $b = b$. The steps to calculate the next iteration are as follows:

- 1) Determine the vector R_k to enter the basis
- 2) Calculate the vector $Y_k = B^{-1}R_k$. If $Y_k \leq 0$, there is no finite optimum. Otherwise, application of the exit criterion of the simplex method will determine the vector a_i which is to leave. That is:

$$\text{Minimum } \frac{b_j^*}{y_{jk}} \quad \forall j \quad i = \text{subscript of leaving variable}$$

- 3) Calculate the inverse of the new basis B^{-1} following the rules:

Rule 1 - Divide row i in B^{-1} by Y_{ik}

Rule 2 - Multiply the new row i by Y_{jk} , and subtract from row $j \neq i$ to obtain new row j

- 4) Calculate new $b^* = B^{-1}b^*$ (old), modify R matrix by substituting the R_k vector by the vector a_i .

5) Calculate the new values of $T = C_R - C_B B^{-1} R$, where C_R and C_B are the objective function coefficients of the non-basic and basic variables respectively. If $T < 0$ we have obtained a maximum. If $T > 0$, find k for maximum $T_1 \nabla 1$ and go to step one.

6) The optimum solution is given by the basic variables, their values are equal to $B^{-1}b$, and the objective function is $Z = C_B B^{-1}b$.

Example 1A

$$\text{Maximum } Z = 3X_1 + 2X_2$$

S.t.

$$2X_1 + X_2 + S_1 \leq 8$$

$$X_1 + 3X_2 + S_2 \leq 12$$

$$X_1 + X_2 + S_3 \leq 5$$

$$X_1, X_2 \geq 0$$

1st Basic Feasible Solution

$$X_B = \begin{bmatrix} S_1 \\ S_2 \\ S_3 \end{bmatrix} \quad B^{-1} = \begin{bmatrix} 1 & 0 & 0 \\ 0 & 1 & 0 \\ 0 & 0 & 1 \end{bmatrix} \quad b^* = \begin{bmatrix} 8 \\ 12 \\ 5 \end{bmatrix}$$

$$C_B = (0, 0, 0) \quad R = \begin{array}{c} X_1 \quad X_2 \\ \begin{bmatrix} 2 & 1 \\ 1 & 3 \\ 1 & 1 \end{bmatrix} \end{array}$$

$$C_B B^{-1} R = (0, 0) \quad C_R = (3, 2)$$

$$T = C_R - C_B B^{-1} R = (3, 2) < 0 \quad \text{Non Optimum}$$

$$\text{Maximum } T_1 = (3, 2) = 3, \quad K = 1$$

$$1) \text{ Enter } X_1 \quad R_1 = \begin{bmatrix} 2 \\ 1 \\ 1 \end{bmatrix}$$

$$2) Y_1 = B^{-1} \begin{bmatrix} 2 \\ 1 \\ 1 \end{bmatrix} = \begin{bmatrix} 2 \\ 1 \\ 1 \end{bmatrix}$$

$$\text{Minimum } \frac{b_j^*}{y_{jk}} = \left[\frac{8}{2}, \frac{12}{1}, \frac{5}{1} \right] = 4, \quad i = 1 \quad S_1 \text{ Leaves}$$

$$3) y_{11} = 2 \quad B_1 = 1/2 (1, 0, 0) = (1/2, 0, 0)$$

$$y_{21} = 1 \quad B_2 = (0, 1, 0) - 1(1/2, 0, 0) = (-1/2, 1, 0)$$

$$y_3 = 1 \quad B_3 = (0, 0, 1) - 1(1/2, 0, 0) = (-1/2, 0, 1)$$

$$B^{-1} = \begin{bmatrix} .5 & 0 & 0 \\ -.5 & 1 & 0 \\ -.5 & 0 & 1 \end{bmatrix}$$

$$4) b^* = B^{-1} \begin{bmatrix} 8 \\ 12 \\ 5 \end{bmatrix} = \begin{bmatrix} 4 \\ 8 \\ 1 \end{bmatrix} \quad R = \begin{array}{cc} S_1 & X_2 \\ \begin{bmatrix} 1 \\ 0 \\ 0 \end{bmatrix} & \begin{bmatrix} 1 \\ 3 \\ 1 \end{bmatrix} \end{array}$$

$$5) C_B = (3, 0, 0) \quad C_R = (0, 2)$$

$$C_B B^{-1} R = (1.5, 1.5)$$

$$T = C_R - C_B B^{-1} R = (-1.5, 0.5) < 0 \quad \text{Non Optimum}$$

$$\text{Maximum } T_1 = (-1.5, 0.5) = 0.5, \quad K = 2$$

$$1) \text{ Enter } X_2 \quad R_2 = \begin{bmatrix} 1 \\ 3 \\ 1 \end{bmatrix}$$

$$2) Y_2 = B^{-1} \begin{bmatrix} 1 \\ 3 \\ 1 \end{bmatrix} = \begin{bmatrix} .5 \\ 2.5 \\ .5 \end{bmatrix}$$

$$\text{Minimum} \left[\frac{4}{.5}, \frac{8}{2.5}, \frac{1}{.5} \right] = 2, \quad i = 3$$

$$3) \begin{aligned} y_{23} &= 1/2 & B_3 &= 2(-1/2, 0, 1) = (-1, 0, 2) \\ y_{21} &= 1/2 & B_1 &= (1/2, 0, 0) - 1/2(-1, 0, 2) = (1, 0, -1) \\ y_{22} &= 2.5 & B_2 &= (-1/2, 1, 0) - 2.5(-1, 0, 2) = (2, 1, -5) \\ B^{-1} &= \begin{bmatrix} 1 & 0 & -1 \\ 2 & 1 & -5 \\ -1 & 0 & 2 \end{bmatrix} \end{aligned}$$

$$4) b^* = B^{-1} \begin{bmatrix} 4 \\ 8 \\ 1 \end{bmatrix} = \begin{bmatrix} 3 \\ 11 \\ -2 \end{bmatrix} \quad R = \begin{array}{cc} & \begin{matrix} s_1 & s_3 \end{matrix} \\ \begin{bmatrix} 1 \\ 0 \\ 0 \end{bmatrix} & \begin{bmatrix} 0 \\ 0 \\ 1 \end{bmatrix} \end{array}$$

$$5) \begin{aligned} C_B &= (3, 0, 2) & C_R &= (0, 0) \\ C_B B^{-1} &= (1, 0, 1) \\ C_B B^{-1} R &= (1, 1) \\ T = C_R - C_B B^{-1} R &= (-1, -1) < 0 \quad \text{A Optimum Solution has been} \\ &\text{reached.} \end{aligned}$$

$$6) \quad x_B = \begin{bmatrix} x_1 \\ s_2 \\ x_2 \end{bmatrix} = B^{-1}b = \begin{bmatrix} 1 & 0 & -1 \\ 2 & 1 & -5 \\ -1 & 0 & 2 \end{bmatrix} \begin{bmatrix} 8 \\ 12 \\ 5 \end{bmatrix} = \begin{bmatrix} 3 \\ 3 \\ 2 \end{bmatrix}$$

$$x_1 = 3, \quad x_2 = 2$$

$$z = c_B B^{-1}b = (1, 0, 1) \begin{bmatrix} 8 \\ 12 \\ 5 \end{bmatrix} = 13$$

Duality¹⁰

The linear programming problem (primal)

$$\text{Minimize } Z_p = CX$$

$$\text{S.t. } AX \geq b$$

$$x_j \geq 0 \quad j=1, 2, \dots, n$$

Has a dual

$$\text{Maximize } Z_d = b^1 W$$

$$\text{S.t. } A^1 W \leq c^1$$

$$w_i \geq 0 \quad i = 1, 2, \dots, m$$

Where A^1 is the transpose of A , b^1 of b and c^1 of c .

These two sets of equations have some interesting relationships.

The most important one is that if one possesses a feasible solution so does the other one and their optimum objective function value is the same. That is:

$$\text{Minimum (opt) } Z_p = \text{maximum (opt) } Z_D$$

Also the primal solution is contained in the dual, in particular in the cost coefficients of the slack variables, and viceverse. Moreover, the dual of the dual is the primal and we can look at performing simplex iterations on the dual, where the rows in the primal correspond to columns in the dual.

Example 2 A

Find the dual and its solution for example 1.A.

$$\text{Max } Z_p = 3X_1 + 2X_2$$

$$\text{S.t. } 2X_1 + X_2 \leq 8$$

$$X_1 + 3X_2 \leq 12$$

$$X_1 + X_2 \leq 5$$

$$X_1, X_2 \geq 0$$

a) The dual is

$$\text{Min } Z_D = 8W_1 + 12W_2 + 5W_3$$

$$\text{S.t. } 2W_1 + W_2 + W_3 \geq 3$$

$$W_2 + 3W_3 \geq 2$$

$$W_1, W_2, W_3 \geq 0$$

b) The dual solution is given by the value of the cost coefficients of the slack variables of the primal (which is, example 1A). These values are found in the vector $(CB^{-1})'$

$$W' = C B^{-1} = [1, 0, 1]$$

$$W_1 = 1, W_2 = 0, W_3 = 1$$

$$Z_d = b'W = Z'_d = W'b$$

$$\text{and } Z_d = W'b = [1, 0, 1] \begin{bmatrix} 8 \\ 12 \\ 5 \end{bmatrix} = 13$$

APPENDIX B
1 COMPUTER PROGRAM

```
10 DIM Z(1,5),R(2,2),Y(2,1),D(2,1)
11 DIM C(1,2),E(1,5),F(2,1),G(2,1),W(2,1)
12 DIM P(1,2),A(2,2),R(2,5)
15 FOR K=.125 TO 6 STEP .125
16 PRINT
17 PRINT
18 PRINT "    K=";K
20 FOR X=.125 TO 2.5 STEP .125
25 IF X<1.321*K THEN 40
30 LET M=X
35 GOTO 45
40 LET M=1.321*K
45 LET Z(1,1)=1.321*K
50 LET Z(1,2)=M
55 LET Z(1,3)=X
60 LET Z(1,4)=X+K
65 LET Z(1,5)=X+K
70 LET D(1,1)=2*X
75 LET D(2,1)=1
80 LET R(1,1)=0
85 LET R(1,2)=2
90 LET R(1,3)=4
95 LET R(1,4)=2
100 LET R(1,5)=4
105 LET R(2,1)=4
110 LET R(2,2)=2
115 LET R(2,3)=0
120 LET R(2,4)=4
125 LET R(2,5)=2
130 LET A(1,1)=1
135 LET A(1,2)=0
140 LET A(2,1)=0
145 LET A(2,2)=1
150 MAT C=ZER(1,2)
155 MAT B=IDN(2,2)
159 MAT F=D
160 LET I=2
165 LET Y(1,1)=R(1,1)
170 LET Y(2,1)=R(2,1)
175 MAT W=B*Y
176 MAT Y=W
180 MAT G=B*F
181 MAT F=G
215 IF Y(1,1)>0 THEN 230
220 GOTO 272
230 IF Y(2,1)>0 THEN 250
240 GOTO 255
```

```
250 IF F[1,1]/Y[1,1]-F[2,1]/Y[2,1]>0 THEN 272
255 LET J=1
260 LET L=2
270 GOTO 280
272 LET J=2
275 LET L=1
280 LET B[J,1]=B[J,1]/Y[J,1]
285 LET B[J,2]=B[J,2]/Y[J,1]
290 LET B[L,1]=B[L,1]-B[J,1]*Y[L,1]
295 LET B[L,2]=B[L,2]-B[J,2]*Y[L,1]
300 LET A1=Z[1,1]
305 LET Z[1,1]=C[1,J]
310 LET C[1,J]=A1
315 LET A1=A[1,J]
320 LET A[1,J]=R[1,1]
325 LET R[1,1]=A1
330 LET A1=A[2,J]
335 LET A[2,J]=R[2,1]
340 LET R[2,1]=A1
345 MAT P=C*B
350 MAT E=P*R
355 MAT E=Z-E
370 LET A2=E[1,1]
371 LET I=1
375 FOR H=2 TO 5
380 IF A2-E[1,H]>0 THEN 395
385 LET A2=E[1,H]
390 LET I=H
395 NEXT H
400 IF A2>0 THEN 165
450 PRINT X
453 MAT PRINT P
454 MAT PRINT A
455 PRINT
460 PRINT
465 NEXT X
475 NEXT K
480 END
```

APPENDIX B. 2

	a _i	b _i	b'	c	d	e
a _i	$4M_b = 1.321K$					
b _i	0.33K	$2M_a + 2M_b = 1.321K$				
b'	$0.5(X - 0.66K)$ 0.33K	$X/4$ $X = 1.321K$ $X/4$	$2M_a + 2M_b = X$			
c	$X/4$ 0.33K	$X/4$ $1/4(2.642K - X)$	$X/4$ $X/4$	$4M_a = X$		
d	$0.5(X - 0.321K)$ 0.33K	$0.5(1.642K - X)$ $0.5(X - 0.321K)$	$0.5(X - K)$ $K/2$	$X/4$ $1.8(2K + X)$	$2M_a + 4M_b = K + X$	
e	$1/4(X - 1.64K)$ 0.33K	$0.5(X - 0.321K)$ $0.5(1.64K - X)$	$K/2$ $1/2(X - K)$	$X/4$ $K/2$	$1/6(K + X)$	$4M_a + 2M_b = K + X$

POSSIBLE BASIC SOLUTIONS

APPENDIX B.3

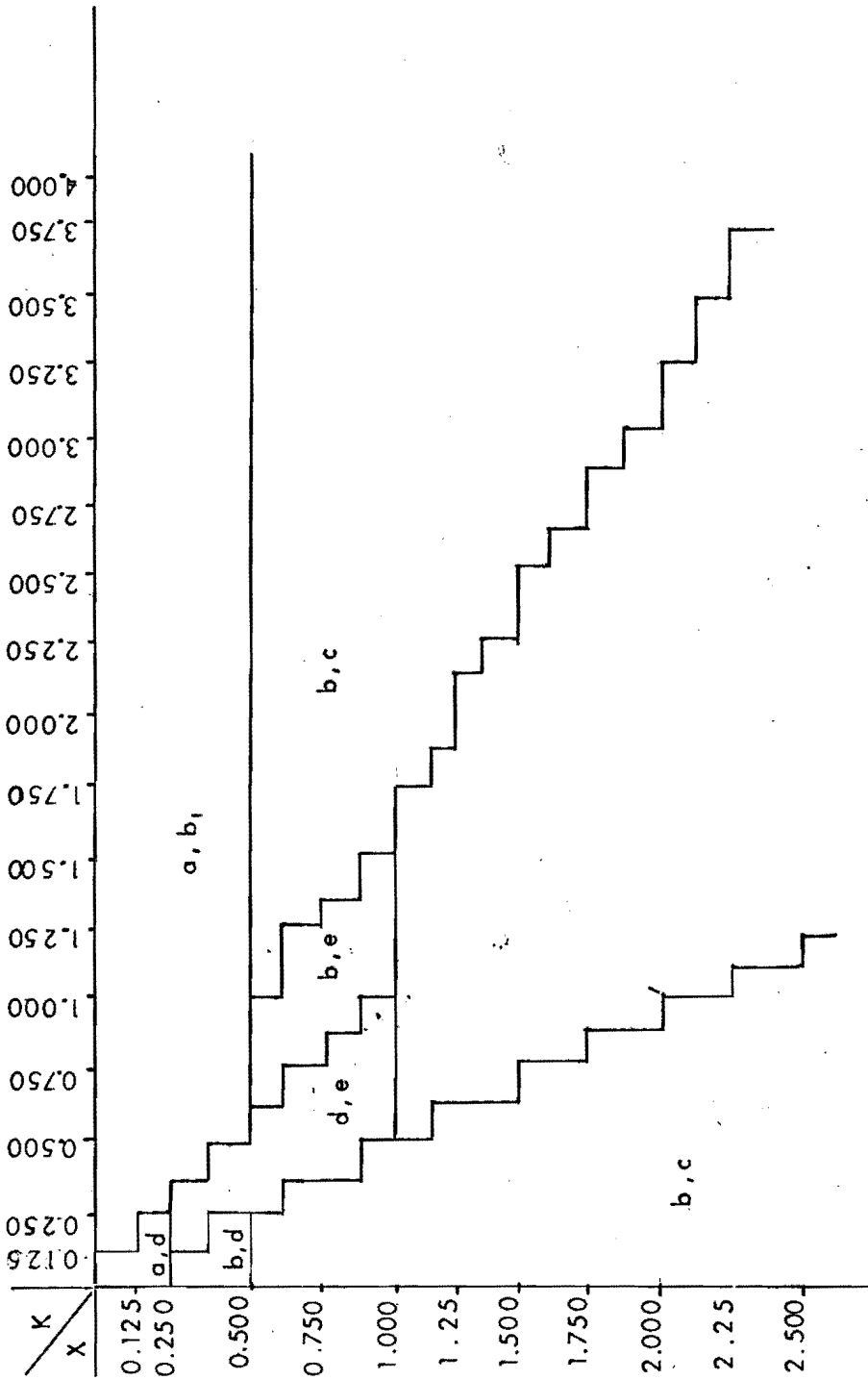

COLLAPSE MECHANISMS OBTAINED BY COMPUTER PROGRAM

APPENDIX C

GRAPH No I

ONE-BAY SINGLE STORY FIXED ENDED PORTAL FRAME

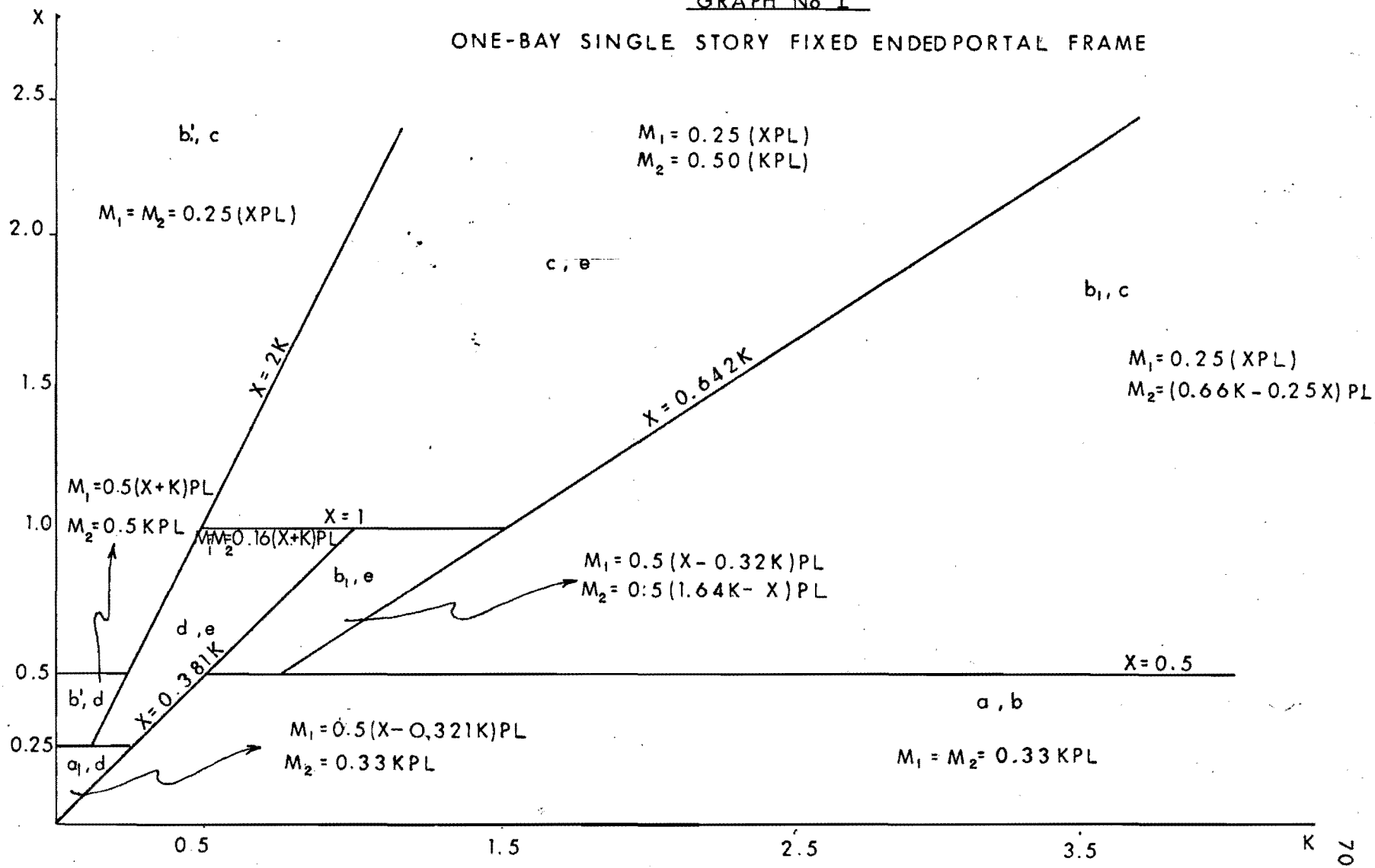

GRAPH No. II
ONE-BAY SINGLE STORY HINGED ENDED PORTAL FRAME

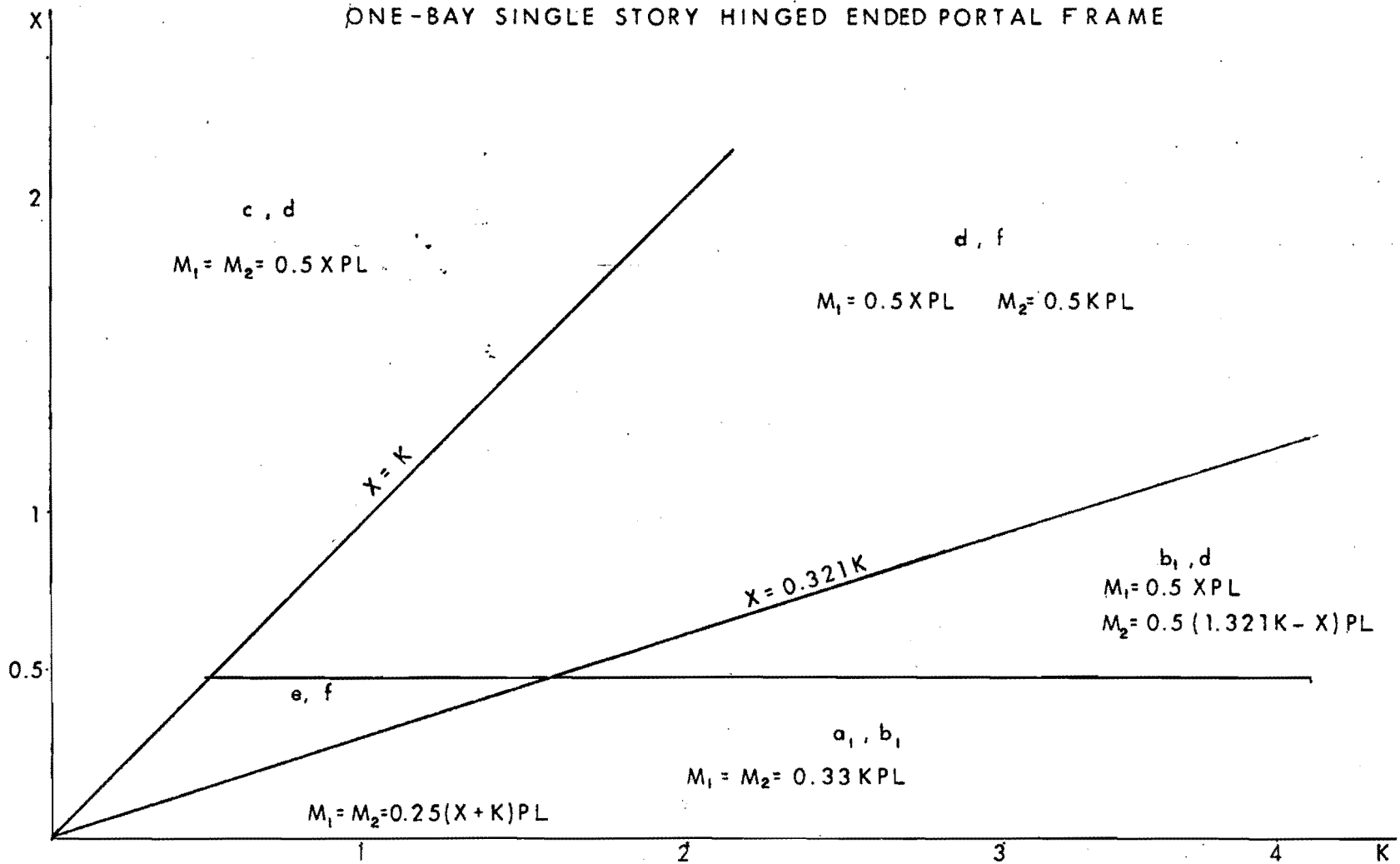

APPENDIX D REFERENCES

1. Foulkes, J., "The Minimum Weight Design of Structural Frames," Proceedings of Royal Society, London, Series A, Vol. 223, 1954, p. 482.
2. Heyman, J., and Prager, W., "Automatic Minimum Weight Design of Steel Frames," Journal of the Franklin Institute, Philadelphia, Pa., Vol. 266, p. 339.
3. Rubinstein, Moshe F., and Karagozian, John, "Building Design Using Linear Programming," Journal of the Structural Division, Proceedings of the American Society of Civil Engineers, Vol. 92, December 1966, p. 223.
4. Bigelow, Richard H., and Gaylord, Edwin H., "Design of Steel Frames for Minimum Weight," Journal of the Structural Division, Proceedings of the American Society of Civil Engineers, Vol. 92, December 1967, p. 109.
5. Romstad, Karl M., and Wang, Chu-Kia, "Optimum Design of Framed Structures," Journal of the Structural Division, ASCE, Vol. 94, No. ST12, Proc. Paper 6273, December, 1968, p. 2817.
6. Massonnet, C. E., and Save, M. A., "Plastic Analysis and Design," Blaisdell Publishing Company, New York, 1965.
7. Beedle, Lynn S., "Plastic Design of Steel Frames," John Wiley & Sons, Inc., New York, 1961.
8. American Society of Civil Engineers, "Plastic Design in Steel," 1961.
9. Wagner, H. M., "Principles of Operations Research," Prentice-Hall, Englewood-Cliff, New Jersey, 1969.
10. Gass, Saul I., "Programacion Lineal, Metodos Y Aplicaciones," Compania Editorial Continental, S. A., Mexico, 1961.