



STANFORD UNIVERSITY
ENGINEERING IN MEDICINE AND BIOLOGY

DISPERSION AND ATTENUATION
OF SMALL ARTIFICIAL PRESSURE WAVES
IN THE AORTA

GPO PRICE \$ _____

CFSTI PRICE(S) \$ _____

Hard copy (HC) 3.00

Microfiche (MF) .65

M. ANLIKER¹

M. B. HUSTAND²

E. OGDEN³

ff 653 July 65

DEPT. OF AERONAUTICS AND ASTRONAUTICS
STANFORD UNIVERSITY
380 LOMAX AVENUE AND AIR ENGINEERING DEPT. OF
AERONAUTICS AND ASTRONAUTICS, STANFORD UNIVERSITY
380 LOMAX AVENUE, MENLO PARK, CALIF. 94024

BIOMECHANICS LABORATORY

FACILITY FORM 402	N 6R-24915	
	(ACCESSION NUMBER)	(THRU)
	43	1
	(PAGES)	(CODE)
CP 94696	04	
(NASA CR OR TMX OR AD NUMBER)	(CATEGORY)	

1965

1965

Department of Aeronautics and Astronautics
Stanford University
Stanford, California

DISPERSION AND ATTENUATION OF
SMALL ARTIFICIAL PRESSURE WAVES IN THE AORTA

by

Max Anliker,[†] Michael B. Hestand[‡]
and
Eric Ogden,[‡] Ames Research Center, NASA

SUDAAR NO. 342
April 1968

[†] Associate Professor

[‡] Ph. D. Candidate and NSF Trainee

[‡] Chief, Environmental Biology Division

This work was carried out at the Ames Research Center of NASA
with the support of NASA Grant NGR 05-020-223

ABSTRACT

A new method was developed to determine the elastic behavior of large blood vessels in terms of their transmission characteristics for small sinusoidal pressure signals. The method utilizes transient signals of the form of finite trains of sine waves that are superimposed on the naturally occurring pressure fluctuations and are generated by an electrically driven impactor or by a pump. Its application to the thoracic aortae of 18 mature mongrel dogs anesthetized with Nembutal has shown that dispersion and attenuation data for frequencies between 40 and 200 cps can be obtained without requiring either Fourier transform computations or resolution of reflection interference. For the frequency range considered, the aorta is only mildly dispersive but exhibits strong attenuation that must be attributed primarily to dissipative mechanisms in the vessel wall. At normal blood pressure levels the wave speed during diastole can have a value between 4 and 6 m/sec. For all frequencies tested the amplitude ratio of the waves exhibits the same exponential decay pattern with distance measured in wavelengths. A marked increase in wave speed is observed from diastole to systole that can be associated with an increase in mean flow and with a stiffening of the aortic wall due to the rise in pressure. This phenomenon implies that the aortae of anesthetized dogs should exhibit nonlinear properties with respect to large amplitude pulse waves such as those generated by the heart.

Key Words: elastic behavior of blood vessels
 dissipative mechanisms
 phase velocity
 wave generator
 nonlinear properties of aorta
 wave transmission characteristics
 catheter-tip manometer
 non-axisymmetric waves

INTRODUCTION

This communication is one of a series (1, 2) dealing with the mechanical properties of blood vessels in terms of their wave transmission characteristics. It describes a new experimental approach to the determination of the distensibility of large arteries and veins by measuring the dispersion and attenuation of artificially induced pressure waves. Even though the experimental results given in this paper have been exclusively obtained from the aortae of anesthetized dogs, the data are expected to be helpful in the selection of an appropriate mathematical model for the mechanical behavior of blood vessels in general. Specifically, it is hoped that the results will be useful in the determination of the constitutive laws obeyed by the walls of arteries and veins (3, 4).

Various mathematical models for the mechanical behavior of blood vessels have been proposed and utilized to predict the propagation characteristics of sinusoidal pressure waves in the circulatory system. Significant theoretical contributions have been made by Witzig (5), Iberall (6), Morgan and Kiely (7), Womersly (8), Hardung (9), Klip (10) and many other investigators. Comprehensive reviews of theoretical as well as experimental investigations of wave transmission in blood vessels and hemodynamic problems in general have been made by McDonald (11), Fox and Saibel (12), Rudinger (13), Skalak (14) and Fung (15).

Experimental data on the mechanical properties of various blood vessels have been obtained by four different approaches:

- 1) Force-displacement measurements on excised vessels (16, 17, 18)
- 2) Force-displacement measurements on vessels in situ or in vivo (3, 19, 20)
- 3) Determination of the propagation characteristics of individual harmonic components of the natural pulse wave generated by the heart (21, 22)

4) Measurement of transmission characteristics of artificially induced pressure waves (23, 24, 25)

None of these approaches is ideal from all points of view, but it appears that the last one should be given preference for a variety of reasons. The removal of the vessels from their natural surroundings raises a multitude of physiological questions and also introduces some mechanical uncertainties regarding the simulation of the forces and constraints to which the vessels are subjected under natural conditions. Force-displacement measurements on vessels under in-vivo conditions seem to be more meaningful, particularly when the circulation through the vessel of interest does not have to be interrupted; however, the question of the extent to which this measuring technique alters the "normal" mechanical behavior of the vessel still exists. The accuracy of data derived from an analysis of the propagation characteristics of individual harmonic components of the pulse wave generated by the heart is highly debatable. There is increasing evidence that the transmission of the natural pulse is influenced by nonlinear phenomena that preclude in a strict sense its resolution into harmonic components for the purpose of determining their speeds and attenuation (26, 27). The data presented in this paper appear to lend further support to this view.

With the development of extremely sensitive displacement-, pressure- and flow-transducers with a high frequency response it has become possible to measure accurately in various large blood vessels the propagation characteristics of artificially induced waves of controlled shape and amplitude. The mechanical properties of these vessels can then be determined by making use of recent theoretical studies of the transmission of small waves in arteries and veins (28, 29, 30). The relevance of the properties obtained in this manner depends on the validity of the mathematical

model that was introduced for the mechanical behavior of blood vessels in the theoretical prediction of the wave propagation characteristics. As far as the determination of elastic and viscoelastic properties of the vessel wall are concerned, this approach is obviously an indirect one, and as such somewhat cumbersome. However, its advantages are that it yields essentially local and instantaneous values. The usefulness of such an approach in assessing changes in the elastic behavior of blood vessels caused by altered physiological conditions or vascular diseases is self-evident. Also, with the help of transcutaneous ultrasound sensors the technique should theoretically be applicable to certain vessels in man without requiring the penetration of the skin.

THEORETICAL CONSIDERATIONS

The manner in which a signal is propagated in any medium depends in general on the nature and form of the signal. For example, a pressure pulse of a given shape normally has different propagation characteristics when its amplitude is very large as compared to when its amplitude is small. Large amplitude signals are extremely difficult to analyze mathematically since their behavior is influenced by nonlinear phenomena that can no longer be considered negligible when the amplitude exceeds a certain range. Also, the nonlinear effects do not permit a complex propagating signal to be synthesized from--or resolved into--simple harmonic components whose properties can be readily defined and analyzed. Therefore, in most theoretical studies the amplitude has been assumed to be sufficiently small to allow for linearization.

The propagation characteristics of small signals in a given medium or system are customarily described by the speed and attenuation of infinitely long trains of sine waves (harmonic waves) as a function of the frequency or wavelength (31). Considering the simplest case of such a train of sine waves with a frequency f propagating in a specified direction, say the x -axis, one can express mathematically the variation of the signal p with the coordinate x and the time t by

$$p(x, t) = A(x) \sin \frac{2\pi f}{c} (x - ct)$$

where $A(x)$ is the amplitude of the signal at station x and c the speed. Since c can be determined from the instantaneous phase difference

$$\frac{2\pi f}{c} \Delta x$$

between two points separated by the distance Δx , the speed of an infinite train of harmonic waves is commonly referred to as phase velocity. When the phase velocity varies with frequency, the system is called dispersive (31). As a convenient

measure for the attenuation of harmonic waves one can use the ratio $\frac{A(x)}{A(x_0)}$ of the amplitude at a distal station x to that at a proximal station x_0 . Henceforth the amplitude at station x will be denoted simply by A and that at station x_0 by A_0 .

In reality one does not have infinitely long trains of harmonic waves since the media are of finite dimensions. Moreover, it may even be impossible to observe finite trains of appreciable length when reflection sites are in close proximity of the point of observation. Therefore, the dispersion and attenuation of infinitely long trains of harmonic signals can practically only be determined from the propagation properties of signals of finite length. When the signals are of non-sinusoidal shape, this requires the laborious evaluation of the Fourier transform of the propagating signal at various locations within the medium and a careful accounting of the uncertainties that may arise from the occurrence of reflections.

For a mildly dispersive medium, i. e. one in which the phase velocity varies less than 10 per cent whenever the frequency is changed by 10 per cent, the need for Fourier transform computations can be circumvented if the transient signal is of the form of a finite train of sine waves. As indicated in Figure 1, the Fourier spectrum of such waves is dominated by the frequency of the sine waves in increasing proportion to the length of the trains. Therefore, the speed of such a signal can be considered a good approximation of the phase velocity corresponding to the frequency of the sine waves. Also, it is possible to avoid the interference of reflections with the transient signal if the signals are of sufficiently short duration or if the medium exhibits strong attenuation. For sufficiently high frequencies and short trains the waves can be recorded before their reflections arrive at the recording site. In the case of strong attenuation, the reflections of a small wave can be completely damped out before they reach the transducer location.

METHODS

Guided by the preceding theoretical considerations, the authors have induced small pressure perturbations in the form of finite trains of sine waves in the aortae of 18 anesthetized dogs. The animals weighed 20-40 kg and were anesthetized with 30 mg/kg sodium pentobarbital (Nembutal) intravenously. They were generally mature mongrels of uncertain age. The dogs were in the supine position throughout the experiment and artificially ventilated with room air at the rate of 9 to 11 liters per minute by means of a Palmer respirator. The blood pressure was continuously monitored with the aid of a Statham P23Dd manometer connected to a radio-opaque catheter inserted through the left carotid artery or the omocervical artery and positioned with an X-ray fluoroscope in the aortic arch.

The basic experimental arrangement is schematically illustrated in Figure 2. The pressure signals were generated either by means of a sinusoidal pump or by an electrically driven impactor. When the pump was used, a polyethylene cannula with an internal diameter of 4 mm was inserted through the left subclavian branch into the descending aorta. When the sinusoidal waves were induced with the aid of the impactor, it was positioned over the aorta in such a manner as to produce small indentations of the vessel wall. The impactor was inserted into the chest through an opening in the left 4th or 5th intercostal space or one along the midline. It was usually placed a few cm below the left subclavian branch. In some cases the intercostal branches were ligated and the aorta was freed from its attachment to the thoracic wall. The pressure signals generated by the indentations of the vessel wall or the sinusoidal pump were measured by means of highly sensitive pressure transducers adapted for physiological applications as catheter-tip manometers. Two types of pressure transducers were used

for this purpose. Both were originally designed for the measurement of rapid pressure fluctuations in wind tunnel models. One of the transducers is a commercially available Bytrex pressure cell Model HFD-5^{*)} which utilizes silicon semiconductor strain gauges. The other is a capacitance-type pressure cell recently developed at the Ames Research Center (32). Figure 3 shows a photograph of both types of catheter-tip manometers.

The Bytrex pressure cell has a diameter of 3 mm. It is gold-plated to reduce the corrosive effects of body fluids. The shielded leads and the venting tube are protected by a heat-shrinkable plastic tube forming a leak-proof flexible catheter. The cell has a sensitivity of $80\mu\text{V}/\text{mm Hg}$ with an excitation of 25 volts. It is linear within 1% from 0 to 300 mm Hg, and has a natural frequency above 60 kc in air. The output from the bridge circuit is amplified by means of Astrodata amplifiers Model 885.^{**)}

The capacitance-type pressure cells used in the experiments have a diameter of 1.4 mm or 1.0 mm and are mounted at the tip of a catheter which encloses the electrical leads and the venting tube. The cell forms a part of a capacitance bridge and the signals are recorded with the aid of a 100 kc carrier amplifier. The fundamental frequency of this manometer is 82 kc in air. It allows for a resolution of about .2 mm Hg and is linear within 1% from 0 to 200 mm Hg.

After amplification the signals from both types of catheter-tip transducers were recorded with the aid of galvanometers whose frequency response is flat up to 3300 cps and a Honeywell Visicorder with a paper speed up to 200 cm/sec. The

*) Schaevitz-Bytrex, Inc.
223 Crescent St.
Waltham, Mass. 02154

**) Astrodata, Inc.
240 E. Palais Rd.
Anaheim, Calif. 92805

catheter-tip and Statham manometers, amplifiers and recording equipment were calibrated as a system for each experiment. Also, the catheter-tip transducers were continuously checked for drift and changes in sensitivity with the help of the Statham gauge. The Bytrex catheter-tip manometers were usually inserted through the left and right femoral arteries; the smaller capacitance transducers were inserted through the left and right saphenous arteries and thus did not cause any major blockage of the circulation through the legs.

The relative positions of the catheter-tip manometers and the impactor or pump cannula could readily be varied and measured to an accuracy of 1 mm through the use of an X-ray image intensifier and a radio-opaque grid with a mesh size of 1 cm. Usually the proximal manometer was positioned at a minimal distance of 5 to 6 cm from the wave generator and the distance between the transducers was systematically varied in increments of 1 or 2 cm. For wave studies in the thoracic aorta the maximum distance between transducers was generally less than 12 cm.

In most of the experiments the trains of sine waves were generated by an electrically driven impactor. One of the electric pistons or impactors used is shown in Figure 4. It consists of a solenoid whose core is connected to a light rod which indents the blood vessel. The rod is protected by a stiff tube which also serves as the support of a hook placed around the vessel. For repetitive generation of sinusoidal signals the size of the hook should be compatible with the size of the artery. A sinusoidal motion of the piston is induced with the aid of an electronic oscillator and a high fidelity amplifier. The number of sine waves and the intervals between the trains are controlled by a tone burst generator.

Since the displacements of the vessel wall caused by the electrically driven impactor have axisymmetric as well as non-axisymmetric components, the corresponding pressure fluctuations must also be expected to exhibit components

of both kinds. Theoretical studies show that the propagation characteristics of non-axisymmetric waves are vastly different from those of axisymmetric disturbances (1, 2). The presence of non-axisymmetric components may make it therefore impossible to observe a single finite train of sine waves, at least within close proximity of the wave generator. Fortunately, these non-axisymmetric waves are completely attenuated within a distance of about ten vessel radii (5 to 6 cm) from the impactor. This has been verified by comparing the pressure recordings from two transducers positioned at different points of a given lumen cross-section. When the amplitude and the phase difference between the two pressure signals were negligible for any relative location of the transducers in that cross-section, it was concluded that the signal was axisymmetric.

It is relatively easy to determine the speed of a train of small sinusoidal pressure perturbations by measuring the transmission time of readily identifiable corresponding points of the signal. As illustrated in Figure 5, the authors selected as characteristic points the intersections of the tangents at successive inflection points. From the time Δt (8 milliseconds) it takes for this point to travel the distance Δx (4 cm) between the transducers the signal speed $\frac{\Delta x}{\Delta t}$ (5 m/sec) can be computed. This signal speed is interpreted as an approximation of the phase velocity corresponding to the frequency of the sine wave which is 70 cps in this particular case. With a recording speed of 100 cm/sec and time lines at 10 millisecond intervals it was in most cases possible to determine time lag Δt with an accuracy of 0.3 milliseconds. The amplitude is defined as indicated in Figure 5 and denoted by A_0 at the proximal transducer and by A at the distal transducer. By measuring Δt and A/A_0 for the various frequencies and distances Δx between the transducers one obtains the dispersion and attenuation characteristics of these waves for different segments of the aorta.

RESULTS

Examples of actual recordings of small pressure signals in the form of finite trains of sine waves superimposed on the naturally occurring pressure fluctuations in the aortae of anesthetized dogs are given in Figure 6. Each of the three pairs of pressure records shown was obtained with the aid of two catheter-tip manometers positioned at different points of the thoracic aorta. The natural pulse wave and the artificially induced pressure signals can easily be recognized. In these instances the frequencies of the sine waves were 70 cps, 100 cps and 140 cps. The recordings in Figures 5 and 6 are from experiments in which the low frequency impacts were deliberately made larger than normal in order to provide a clear illustration. In the data discussed below, the amplitudes of the sine waves were generally less than 5 mm Hg and their frequencies ranged from 40 to 200 cps. Wave trains with frequencies below 40 cps could be recorded over a distance of more than 20 cm. Most of the results given in this paper are based on wave transmission data obtained from a segment of the thoracic aorta less than 12 cm in length to minimize the effects of taper and branching.

The sinusoidal pressure signals were generated at various times in the cardiac cycle in each dog as illustrated in Figure 6. Though attenuated during their propagation, they clearly retained their sinusoidal character. The absence of noticeable distortions of the sinusoidal pressure waves suggests that the aorta is not strongly dispersive for pressure waves in the frequency range considered here and that there are no discernible effects of reflections. In a strongly dispersive medium one should observe "forerunners" (33) of the trains of sine waves, especially when the trains are short. However, no "forerunners" of the pressure signals could be discerned in the aorta. For sinusoidal waves recorded during diastole, the time lag Δt did not vary measurably with the selection of a characteristic point within the same train. This can be interpreted as further evidence that the aorta is not strongly dispersive and that the effects of reflections are negligible.

However, for signals produced during systole, Δt was observed to be noticeably different for different characteristic points within the same train and appeared to vary systematically with the cardiac phase. This implies that the signal speed also varied with the cardiac phase during systole. Theoretical analyses indicate that the wave speed may be affected by both pressure (1, 2, 28) and mean flow (34). Any description of the dispersive nature of the aorta should therefore include a reference to the pressure and mean flow levels at which the wave speeds were determined. A separate study of the effects of a mean flow on the velocity of various waves is now in progress. The dispersion curves given here are restricted to waves generated during the diastolic phase during which the mean flow velocities are insignificant compared with the signal speed (11).

A typical dispersion curve illustrating wave speeds measured in one of the earlier experiments performed by the authors is shown in Figure 7. In this particular case the wave speed is approximately 5.5 m/sec and is nearly independent of frequency between 60 and 200 cps. The attenuation of some of these waves in terms of the amplitude ratio A/A_0 as a function of the distance between the transducers in cm is given in Figure 8. It is evident that the low frequency waves are transmitted over a much larger distance than are the high frequency signals. This attenuation can be attributed to the combined effect of three main causes:

1. Dissipation mechanisms in the vessel wall;
2. Radiation of energy into the surrounding tissue or vascular bed;
3. Viscosity of blood.

The radiation of energy into the surrounding medium must play a minor role in the case of the thoracic aorta since the complete surgical exposure of the thoracic aorta segment in which the waves were studied did not cause a noticeable change in

the dissipation of the waves observed prior to exposure. Moreover, it has been shown theoretically (29) that the viscosity of the blood can only account for a small fraction of the observed attenuation for the frequency range and type of waves considered here. Therefore, the damping of pressure waves can be almost entirely attributed to dissipation mechanisms in the vessel wall.

Knowing the phase velocity c as a function of the frequency one can compute the wavelength $\lambda = \frac{c}{f}$ and represent the attenuation as a function of the non-dimensional distance $\frac{\Delta x}{\lambda}$ for all frequencies. Figure 9 gives the attenuation pattern when A/A_0 is plotted against $\Delta x/\lambda$. It appears that for all frequencies the amplitude ratio A/A_0 decreases in the same exponential fashion with $\frac{\Delta x}{\lambda}$:

$$\frac{A}{A_0} = e^{-k \frac{\Delta x}{\lambda}}$$

where $k = 0.89$ in this particular case. It is therefore convenient to plot A/A_0 on a logarithmic scale as illustrated in Figure 10.

Additional dispersion and attenuation curves representative of a total of 17 further experiments are given in Figures 11 to 16. The results of these experiments indicate that at normal blood pressure levels the wave speed in the thoracic aorta during diastole has a value between 4 and 6 m/sec, while the attenuation coefficient k varies between 0.7 and 1.0 for waves propagating in the peripheral direction. For frequencies below 40 cps the waves induced by the impactor generally no longer had the form of pure sine waves and the data from such waves usually showed a somewhat larger scatter and were therefore not used. Even so, between 20 and 40 cps the waves were sufficiently close facsimiles of pure harmonics to warrant noting that their transmission properties were essentially the same as those for waves with frequencies higher than 40 cps.

The method developed for these experiments permits the generation of transient signals at any instant of the cardiac cycle (Figure 6) and should therefore allow for a study of the combined effects of the naturally occurring pressure- and flow-fluctuations on the transmission characteristics of pressure signals. Also, by occluding the ascending aorta for a few seconds or by stopping the heart through vagal stimulation, the effect of pressure alone on the speed of the sine waves can be determined. The pressure dependence of the phase velocities can then be used as a measure of the change of the elastic properties of the aorta wall with stress.

During systole the speed of the sine trains was consistently evaluated by measuring the time lag Δt of a characteristic point in the middle of the trains. By plotting the corresponding speed as a function of the instantaneous aortic pressure one obtains as typical data those shown in Figures 17-19. The points representing the speeds of waves of different frequencies have been identified by the symbols listed in the left-hand corner of the graphs. In Figures 17 and 18 the data corresponding to extremely low pressures were acquired by occluding the ascending aorta for about 10 seconds, while those in Figure 19 were obtained during vagal stimulation. Figure 17 demonstrates that with a blood pressure of 100/65 mm Hg the wave speed may increase from approximately 4 m/sec at diastole to about 6 m/sec at systole. This result is independent of frequency in the range from 40 to 120 cps. In other words: with a pulse pressure of 35 mm Hg the phase velocity can increase by as much as 50% from diastole to systole. The relatively large scatter of the data points for systolic pressures may be due to the rapid changes in mean flow that occur during the systolic phase of the cardiac cycle.

DISCUSSION

The wave transmission data derived from 18 experiments consistently portrays a very weak dispersion for pressure waves generated during diastole and exhibits in all cases the same exponential decay pattern for the amplitude of a propagating sinusoidal pressure wave. The attenuation per wavelength is nearly independent of frequency between 40 and 200 cps and the attenuation coefficient k ranges from 0.7 to 1.0. Therefore, during propagation over a distance of one wavelength (2 to 15 cm) the amplitude of a sine wave will diminish to about 50% to 30% of its initial value. This loss of energy must be attributed primarily to dissipative mechanisms in the vessel wall since the viscosity of the blood and the radiation of energy into the surroundings of the aorta can only account for a relatively small fraction of the attenuation in the frequency range considered.

The absence of any significant dispersion and reflection interference was indicated by the facts that for small amplitudes the sine waves retained their sinusoidal form during propagation and that the signal speed was independent of the choice of a characteristic point. Under such conditions one can justify interpreting the signal speed as an approximation of the phase velocity corresponding to the frequency of the sine wave and thus avoid the laborious Fourier transform computations.

The frequency and amplitude of the sinusoidal pressure waves could be accurately controlled irrespective of whether they were generated by the pump or by the electrically driven impactor. However, the number of sine waves contained in each train and the interval between the trains were most accurately controlled when the impactor was used. Therefore, in most of the experiments conducted the waves were generated by a controlled tapping of the aorta. To minimize any possible manifestations of nonlinear effects associated with large pressure fluctuations, the amplitudes of the sine waves were generally chosen no larger than necessary for a

precise determination of the signal speed. For wave amplitudes less than 5 mm Hg no evidence of reflections or nonlinear behavior was discernible for frequencies above 40 cps. For frequencies between 20 and 40 cps there were also no obvious manifestations of nonlinear propagation characteristics, but it should be noted that such waves in general exhibited minor distortions, even with small amplitudes. However, these waves were so close to being pure harmonics that their speeds and attenuation may be interpreted as meaningful data with some qualification. For frequencies below 40 cps it was possible to generate waves with amplitudes up to 20 mm Hg. Such waves clearly altered their shape during propagation, but no attempt was made to interpret these changes as the result of reflections or specific nonlinear properties of the aorta.

Of particular significance among the results presented here is the marked increase in wave speed between diastole and systole. This rise in speed can be attributed to two probable causes, a stiffening of the aortic wall with pressure and an increase in mean flow. This phenomenon is now under detailed study, since it implies that the aorta of anesthetized dogs should exhibit nonlinear properties with respect to large amplitude pulse waves such as those generated by the heart. A nonlinear behavior of the aorta in this sense would call for a reassessment of the interpretation of all data derived from the propagation characteristics of individual harmonic components of the natural pulse wave.

The dispersion and attenuation properties of the aorta for a given pressure level and axial stretch can be utilized in the determination of a valid mathematical model for the mechanical behavior of the aorta and specifically in establishing the constitutive laws of the vessel wall. The insignificant dispersion of pressure waves within the frequency range covered by the experiments has been predicted by several

theoretical studies (1, 2, 28-30). In these and other studies it was shown that there are three different kinds of waves that can be transmitted by a vessel of the shape of a circular cylinder. The waves can be distinguished by the corresponding displacement pattern of the vessel defined by the motion of an arbitrary point of the wall in the axial, circumferential and radial directions, as illustrated in Figure 20. The propagation characteristics of the wave will depend strongly on which of the three displacement components (u, v, w) dominates. For example, a wave in which the radial motion of the wall dominates is transmitted at a relatively low speed and exhibits a strong intraluminal pressure fluctuation. Such a wave is generally referred to as a pressure wave. Waves with dominant axial or circumferential wall motion by contrast produce extremely small pressure perturbations but travel at a considerably higher speed than do pressure waves. In references (1) and (2) the three types of waves have been predicted on the basis of a mathematical model in which the elastic and viscoelastic properties of the wall material are free parameters that can be evaluated for example by measuring the propagation characteristics of one type of wave. With this information one can then predict the transmission properties of the other types of waves and by comparing them with those measured in experiments the validity of the model can be conveniently tested.

A quantitative evaluation of changes in the elastic properties of blood vessels on the basis of altered propagation characteristics of waves is only meaningful after a mathematical model has been established which predicts the dispersion and attenuation of the various waves with a reasonable accuracy. After such a model has been arrived at, it should be possible to apply the method described in this communication in a systematic study of the control mechanisms that may govern active changes in the elastic properties of blood vessels.

ACKNOWLEDGMENT

The authors are indebted to Dr. L. Sapirstein for his helpful suggestions in preparing the manuscript and to Mr. R. Westbrook for his assistance in the design of the wave generator.

REFERENCES

1. Anliker, M., and Maxwell, J.: The dispersion of waves in blood vessels. In Biomechanics Symposium, edited by Y. C. Fung. New York, ASME, 1966, pp. 47-67.
2. Maxwell, J., and Anliker, M.: The dissipation and dispersion of small waves in arteries and veins with viscoelastic wall properties. Biophysical J. In press.
3. Fung, Y.C.B.: Elasticity of soft tissues in simple elongation. Am. J. Physiol. 213: 1532, 1967.
4. Prager, W.: On the formulation of constitutive equations for living soft tissues. AFOSR Sci. Rpt. 67-2599, 1967. Defense Documentation Center, Alexandria, Virginia 22314.
5. Witzig, K.: Über erzwungene Wellenbewegungen zäher, inkompressibler Flüssigkeiten in elastischen Röhren. Inaugural Dissertation, Universität Bern, Wyss 1914.
6. Iberall, A.S.: Attenuation of oscillatory pressures in instrument lines. J. of Res. - Nat. Bureau of Stds. 45: 85, 1950.
7. Morgan, G.W., and Kiely, J.P.: Wave propagation in a viscous liquid contained in a flexible tube. J. Acoust. Soc. Am. 26: 326, 1954.
8. Womersley, J.R.: An elastic tube theory of pulse transmission and oscillatory flow in mammalian arteries. WADC Tech. Report TR 56-614. Defense Documentation Center. 1957.
9. Hardung, V.: Propagation of pulse waves in viscoelastic tubings. In Handbook of Physiology, Vol. I, Circulation, edited by W. F. Hamilton. Washington, D. C., Am. Physiol. Soc., 1962, pp. 107-135.
10. Klip, W.: Velocity and Damping of the Pulse Wave. The Hague, Martinus Nijhoff, 1962.
11. McDonald, D.A.: Blood Flow in Arteries. London, Edward Arnold, Ltd., 1960.
12. Fox, E.A., and Saibel, E.: Attempts in the mathematical analysis of blood flow. Trans. Soc. Rheol. 7: 25, 1963.
13. Rudinger, G.: Review of current mathematical methods for the analysis of blood flow. In Biomedical Fluid Mechanics Symposium. New York, ASME, 1966, pp. 1-33.
14. Skalak, R.: Wave propagation in blood flow. In Biomechanics, edited by Y. C. Fung. New York, Applied Mechanics Division ASME, 1966, pp. 20-46.

15. Fung, Y.C.: Biomechanics, its scope, history and some problems of continuum mechanics in physiology. *J. App. Mech. Reviews*, 21: 1, 1968.
16. Fenn, W.O.: Changes in length of blood vessels on inflation. *In* *Tissue Elasticity*, edited by J.W. Remington. Washington, D.C., Am. Physiol. Soc., 1957, pp. 154-160.
17. Bergel, D.C.: The dynamic elastic properties of the arterial wall. *J. Physiol.* 156: 458, 1961.
18. Apter, J.T., and Marquay, E.: Correlation of visco-elastic properties of large arteries with microscopic structure: V. Effects of sinusoidal forcings at low and at resonance frequencies. *Cir. Res.* 22: 393, 1968.
19. Patel, D.J., Greenfield, J.C., and Fry, D.L.: In vivo pressure-length-radius relationship of certain blood vessels in man and dog. *In* *Pulsatile Blood Flow*, edited by E.O. Attinger. New York, 1964, pp. 293-306.
20. Lee, J.S., Frasher, W.G., and Fung, Y.C.: Two dimensional finite deformation experiments on dog's arteries and veins. AFOSR Sci. Rpt. 67-1980, 1967. Defense Documentation Center.
21. McDonald, D.A., and Taylor, M.G.: The hydrodynamics of the arterial circulation. *Prog. Biophys. Biophys. Chem.* 9: 107, 1959.
22. McDonald, D.A.: Regional pulse-wave velocity in the arterial tree. *J. Appl. Physiol.* 24: 73, 1968.
23. Landowne, M.: A method using induced waves to study pressure propagation in human arteries. *Cir. Res.* 5: 594, 1957.
24. Landowne, M.: Characteristics of impact and pulse wave propagation in brachial and radial arteries. *J. Appl. Physiol.* 112: 91, 1958.
25. Peterson, Lysle H., The dynamics of pulsatile blood flow, *Cir. Res.* 2: 127, 1954.
26. King, A.L.: Some studies in tissue elasticity. *In* *Tissue Elasticity*, edited by J.W. Remington. Washington, D.C., Amer. Physiol. Soc., 1957, p. 123.
27. Dick, D., Kendrick, J., Matson, G., and Rideout, V.C.: Measurement of nonlinearity in the arterial system of the dog by a new method. *Cir. Res.* 22: 101, 1968.
28. Atabek, H.B., and Lew, H.S.: Wave propagation through a viscous incompressible fluid contained in an initially stressed elastic tube. *Biophysical J.* 6: 481, 1966.
29. Jones, E., Chang, I-Dee, and Anliker, M.: Effects of viscosity and external constraints on wave transmission in blood vessels, SUDAAR Report No. 344, Dept. of Aeronautics and Astronautics, Stanford University, Stanford, Calif., 1968.

30. Klip, W., Van Loon, P., and Klip, D.: Formulas for phase velocity and damping of longitudinal waves in thick-walled viscoelastic tubes. *J. Appl. Physics* 38: 3745, 1967.
31. Lindsay, R.B.: *Mechanical Radiation*. New York, McGraw-Hill Book Company, Inc., 1960.
32. Coon, G.: Diaphragm type capacitance transducer. U.S. Pat. Off. No. 3,027,769. 1962.
33. Brillouin, L.: *Wave Propagation and Group Velocity*. New York and London, Academic Press, 1960.
34. Morgan, G.W., and Ferrante, W.R.: Wave propagation in elastic tubes filled with streaming liquid. *J. Acoust. Soc. Am.* 27: 715, 1955.

$$f(t) = \frac{1}{2\pi} \int_{-\infty}^{\infty} F(\omega) e^{i\omega t} d\omega$$

$$F(\omega) = \int_{-\infty}^{\infty} f(t) e^{-i\omega t} dt$$

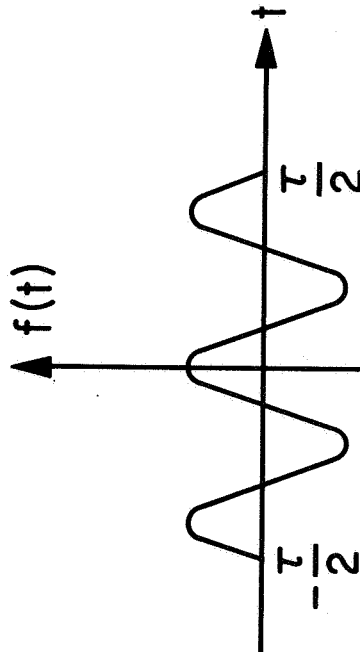

$$f(t) = \begin{cases} \cos(\omega_0 t), & |t| < \frac{\tau}{2} \\ 0, & |t| > \frac{\tau}{2} \end{cases}$$

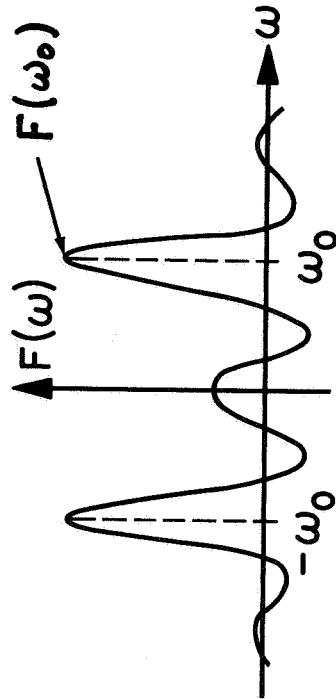

$$F(\omega) = \frac{\tau}{2} \left[\frac{\sin\left(\frac{\omega - \omega_0}{2}\right) \tau}{\left(\frac{\omega - \omega_0}{2}\right) \tau} + \frac{\sin\left(\frac{\omega + \omega_0}{2}\right) \tau}{\left(\frac{\omega + \omega_0}{2}\right) \tau} \right]$$

Figure 1. Fourier transform of finite train of sine waves. $F(\omega_0)$ dominates the spectrum increasingly with the length of the train.

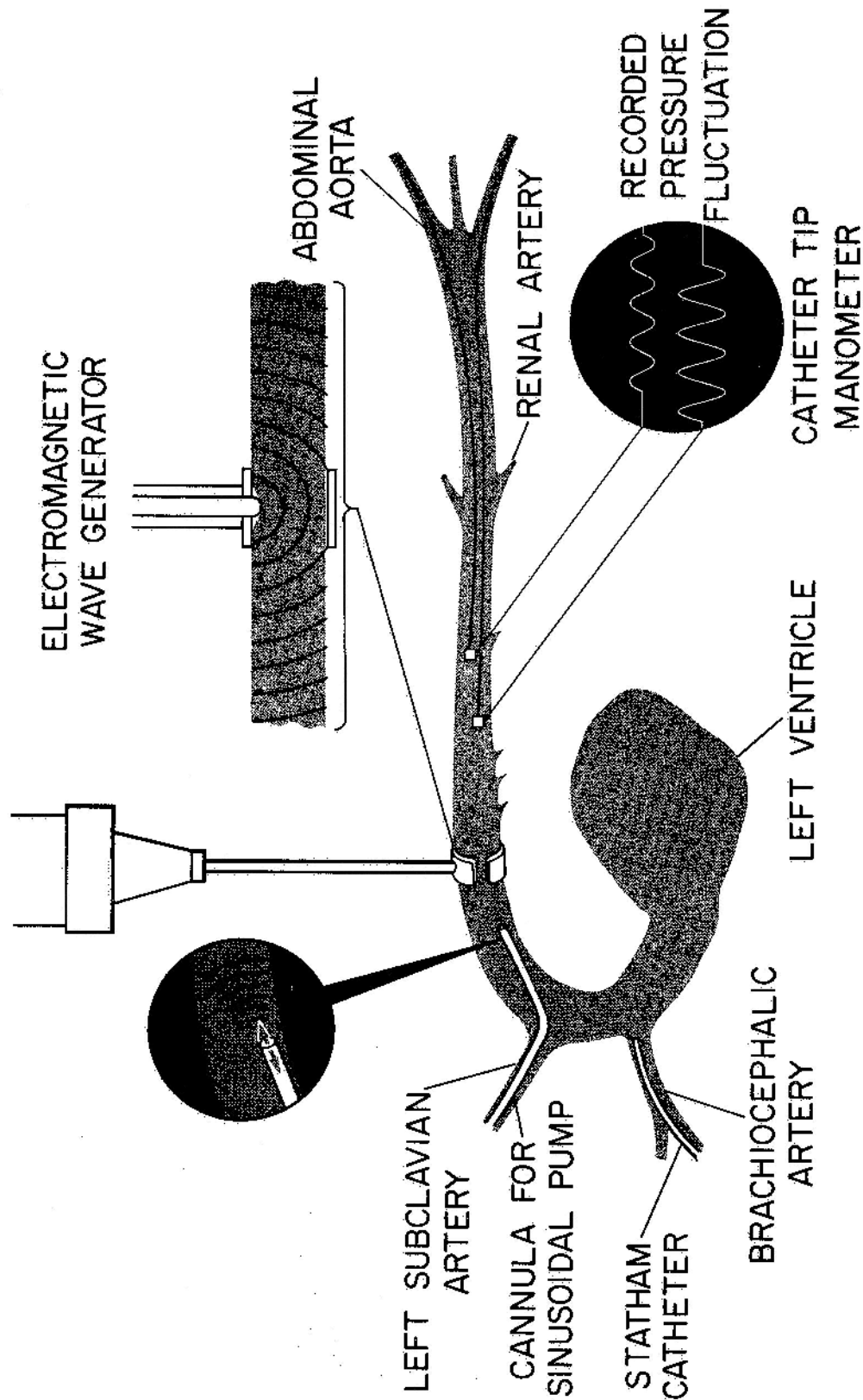

Figure 2. Arrangement of the experimental apparatus for generating and sensing small sinusoidal pressure waves in the aorta of an anesthetized dog. Both methods of inducing the pressure signals are illustrated; however, the wavelengths of the waves indicated in the magnifications of the details showing the cannula and vibrating piston are much shorter than those analyzed in this investigation (2 to 15 cm).



Figure 3. Pressure cells adapted for use as catheter-tip manometers. Left: Bytrex transducer HFD-5 (strain gauge type). Right: Coon pressure sensor (capacitance type) developed by NASA.

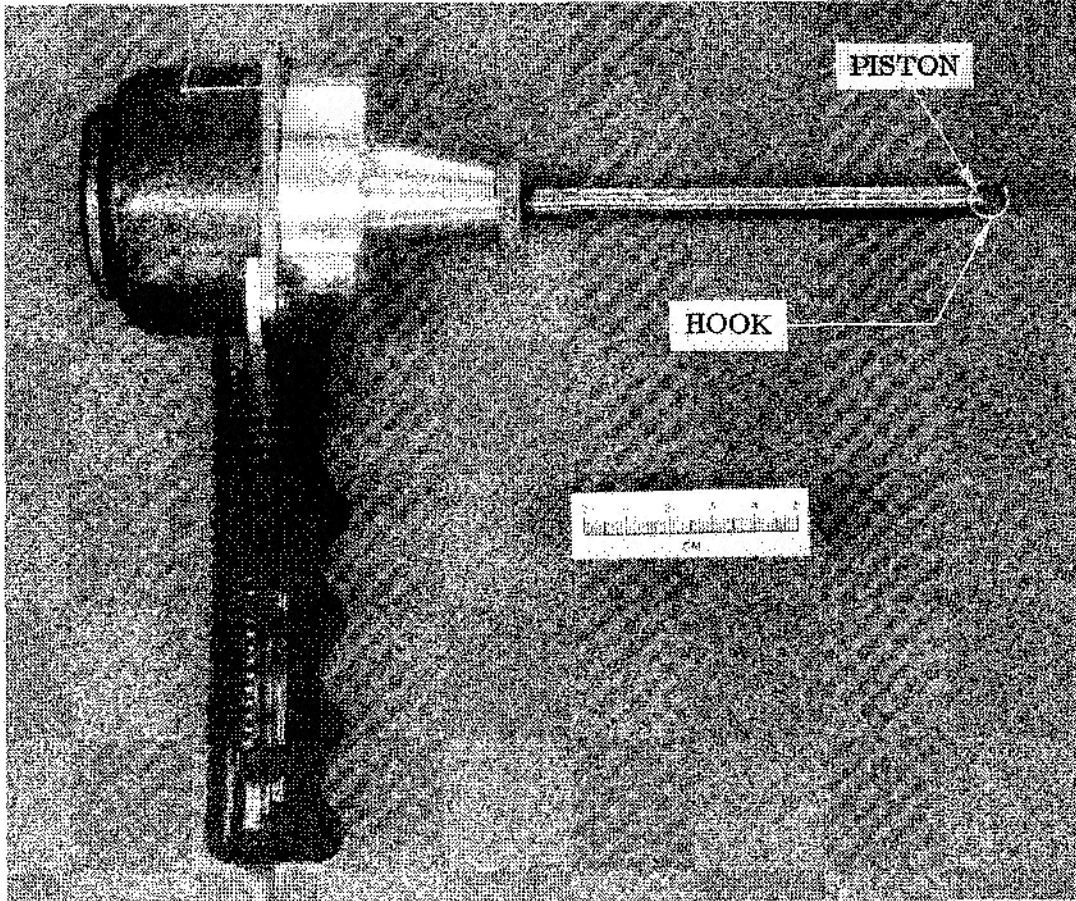
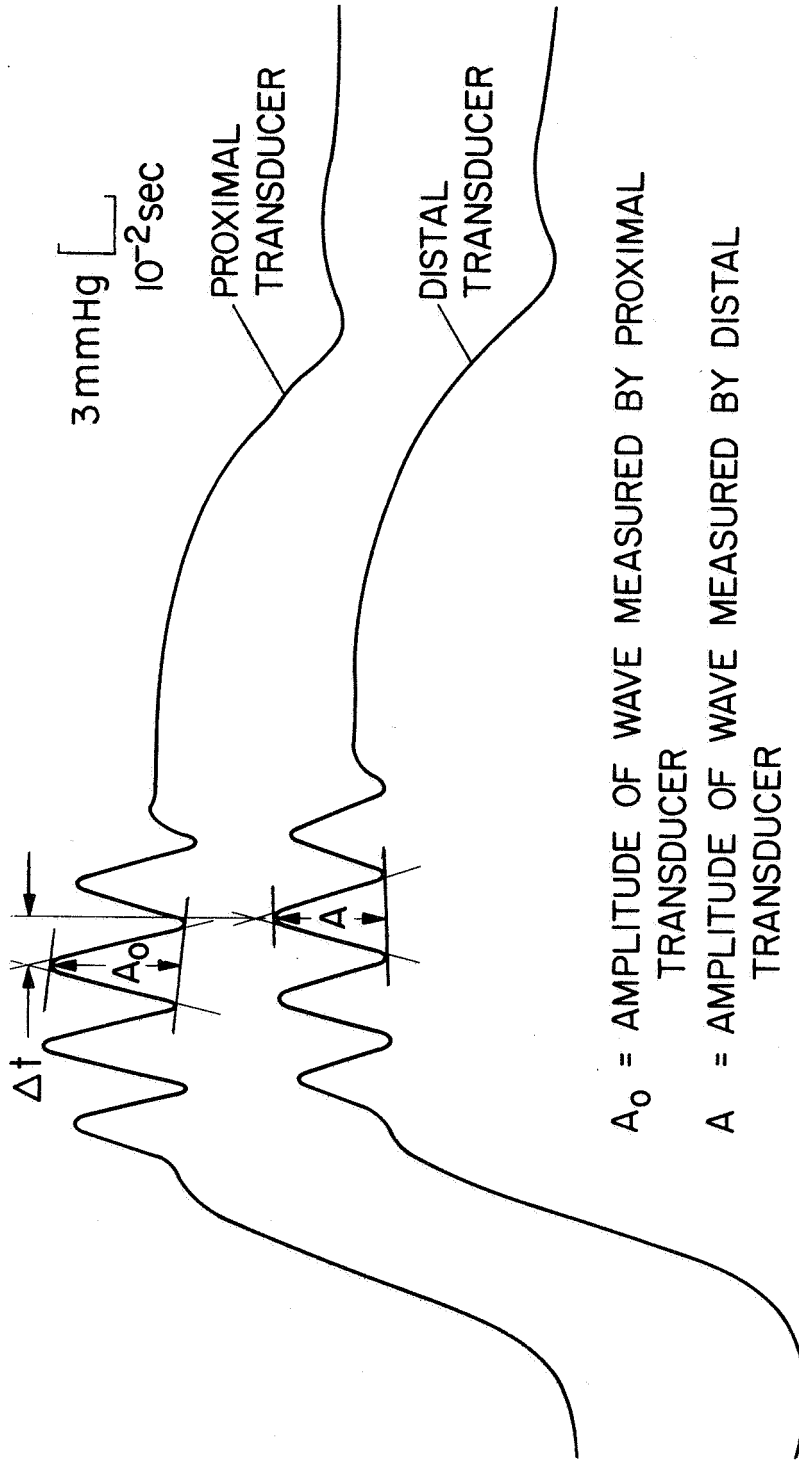

Figure 4. Small electromagnetic wave generator with exchangeable hook. For frequencies between 40 and 80 cps the maximum piston travel in this model is about 3.5 mm while above 80 cps it rapidly diminishes with increasing frequency.

EXAMPLE OF A TYPICAL VISICORDER RECORDING OF A TRAIN
OF 4 SINE WAVES INDUCED AT SYSTOLE

70 cps, $\Delta X = 4$ cm



A_0 = AMPLITUDE OF WAVE MEASURED BY PROXIMAL
TRANSDUCER

A = AMPLITUDE OF WAVE MEASURED BY DISTAL
TRANSDUCER

ΔX = DISTANCE BETWEEN TRANSDUCERS

Δt = TIME LAG IN SECONDS

$V = \Delta X / \Delta t$ APPROXIMATE PHASE VELOCITY AT 70 CPS

Figure 5. Sample recording of a transient pressure signal with illustration of signal speed and amplitude determination. The signal speed was defined by the time lag or transmission time Δt (8 milliseconds) of a characteristic point of the signal for the distance Δx (4 cm) between the transducers. By choosing the intersection of the tangents at two successive inflection points of the sine wave as a characteristic point it was possible to measure Δt to an accuracy of .3 milliseconds. The signal speed V is interpreted as an approximation of the phase velocity.

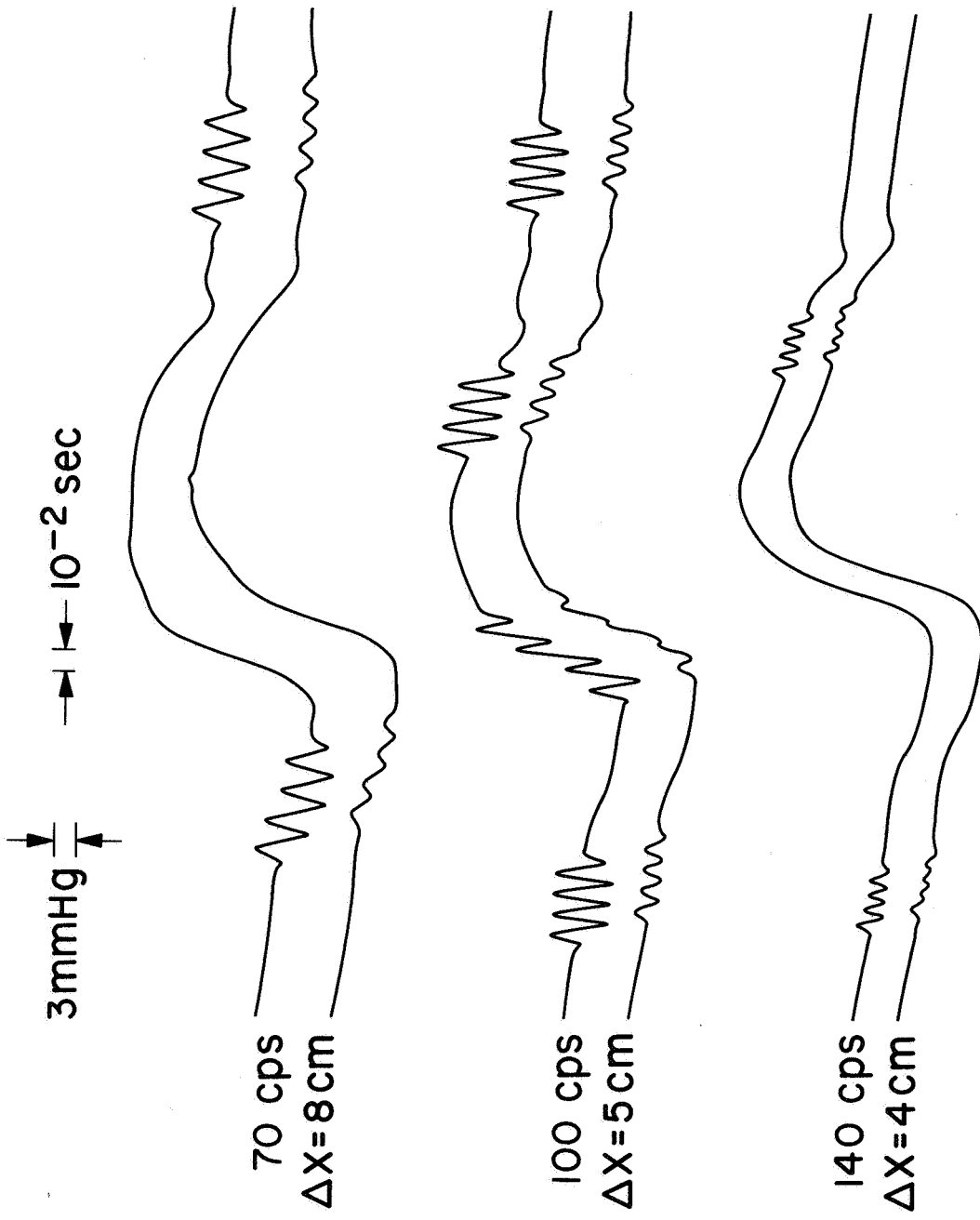

Figure 6. Representative tracings of recordings of the natural pulse wave in the thoracic aorta of an anesthetized dog, with artificially superimposed trains of sinusoidal waves. The transient signals can be induced at any time during the cardiac cycle. Note that the sine waves are highly damped but retain their sinusoidal character during propagation.

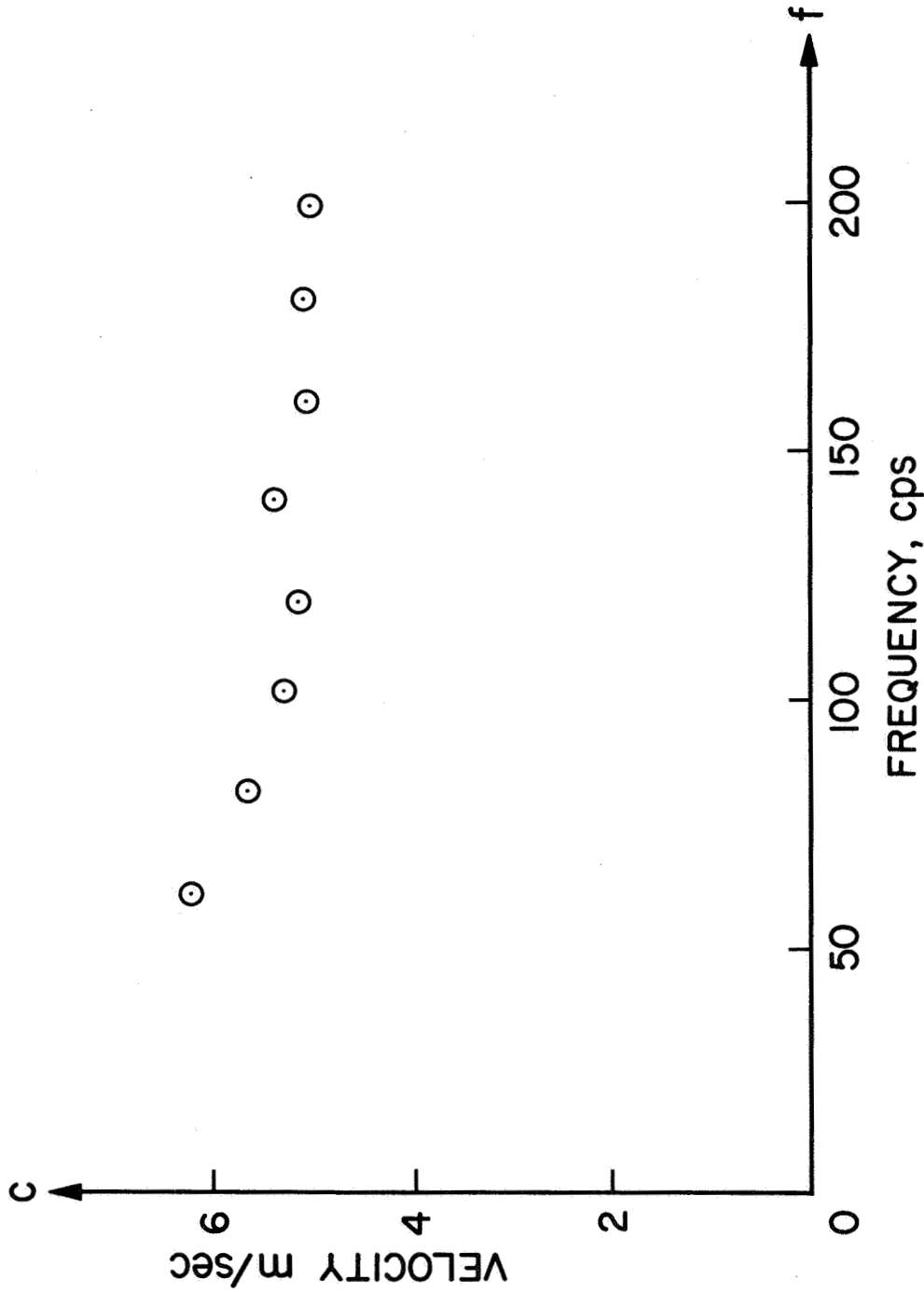

Figure 7. Typical dispersion of waves generated in the thoracic aorta of a dog during diastole. Each point represents an average of 3 to 10 speed measurements of different wave trains at the same pressure levels during diastole. (Exp. #62, Aug. 31, 1966)

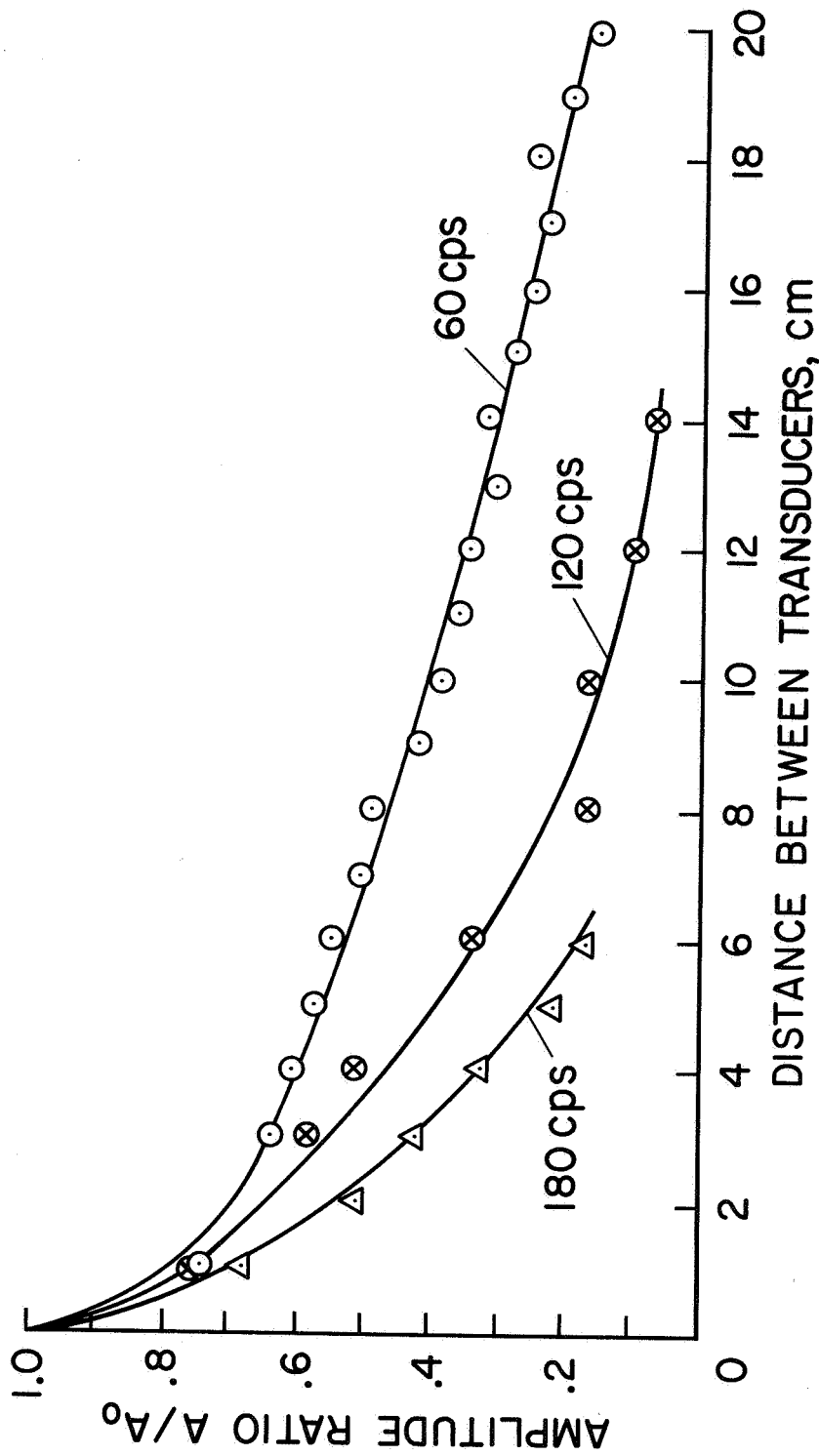

Figure 8. Attenuation of small sinusoidal pressure waves with 3 different frequencies in the aorta of a dog during diastole. The attenuation is given in the form of the amplitude ratio as a function of the distance travelled by the waves measured in cm. Note the rapid dissipation of the signals at higher frequencies. (Exp. #62, Aug. 31, 1966)

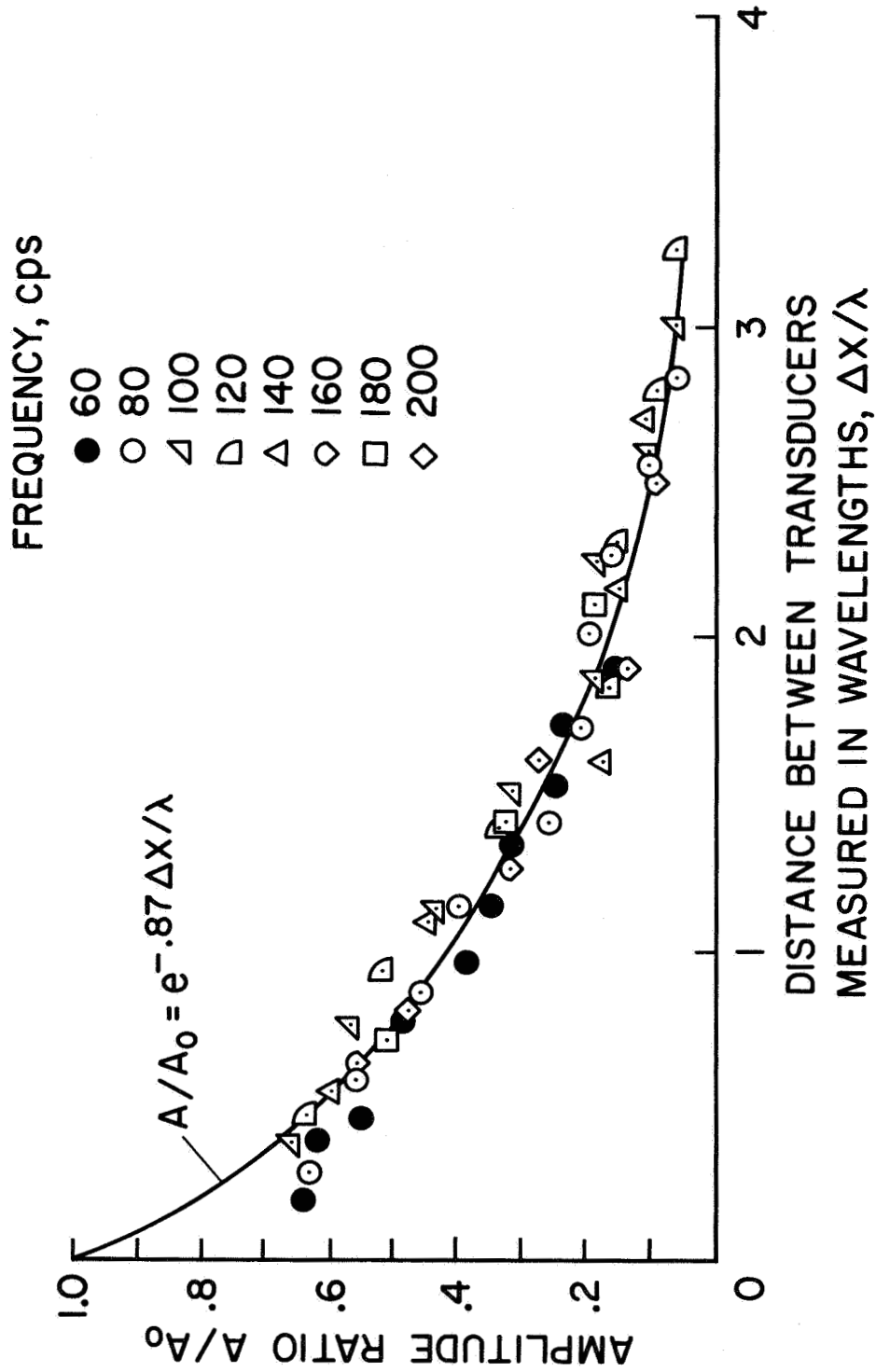

Figure 9. Attenuation of pressure waves in terms of the amplitude ratio as a function of the distance travelled in wavelengths. Some of these data are also shown in Figure 8. Note exponential decay pattern of the wave amplitude independent of frequency. (Extp. #62, Aug. 31, 1966)

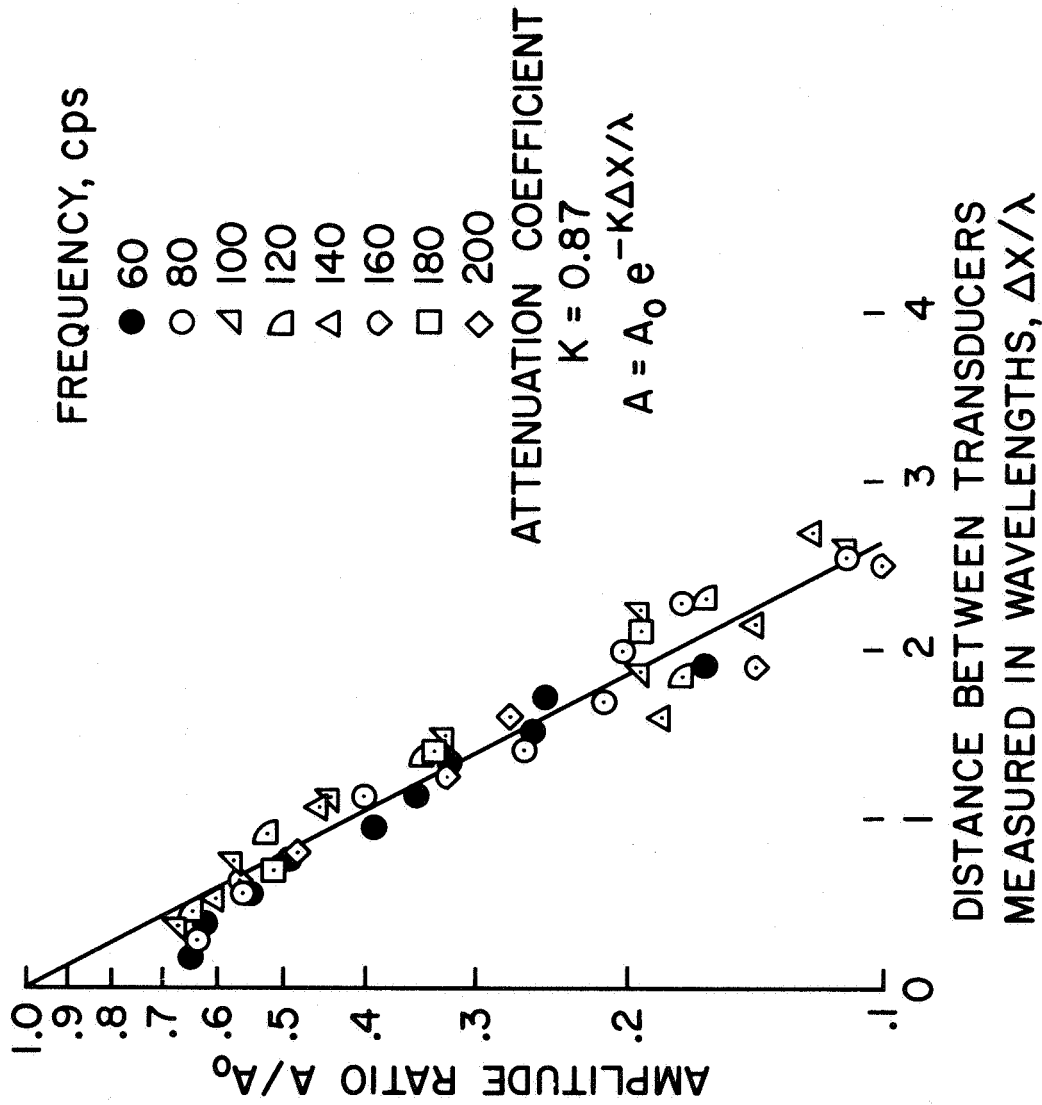
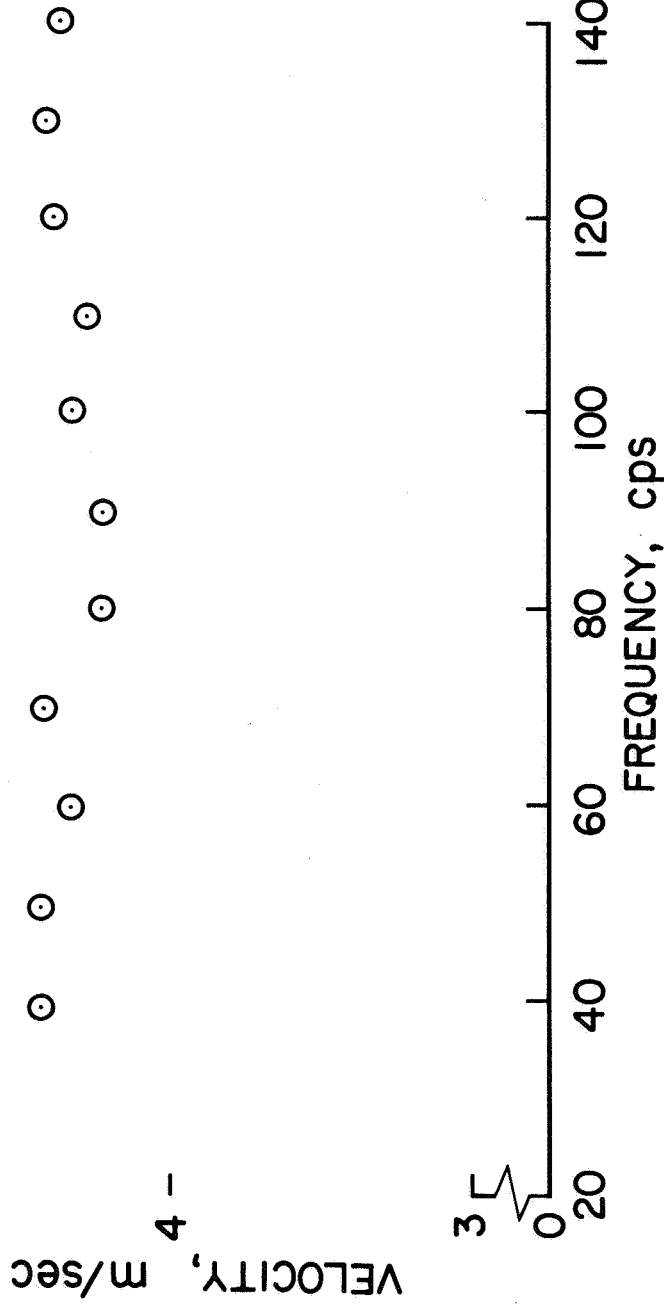

Figure 10. Attenuation data given in Figure 9 with A/A_0 plotted on a logarithmic scale. The slope of the line approximating the variation of $\ln(A/A_0)$ with $\Delta x/\lambda$ defines the attenuation coefficient k , which in this case is .87.

TRANSDUCER LOCATION
 $\Delta X = 4 \text{ cm}$
 AORTIC PRESSURE
 69-77 mmHg DIASTOLIC

5 -



4 -

Figure 11. Dispersion curve for waves generated during diastole at a pressure between 69 and 77 mm Hg. Each point represents an average of 3 to 10 speed measurements of different wave trains at the same pressure levels during diastole. (Exp. #122, May 9, 1967)

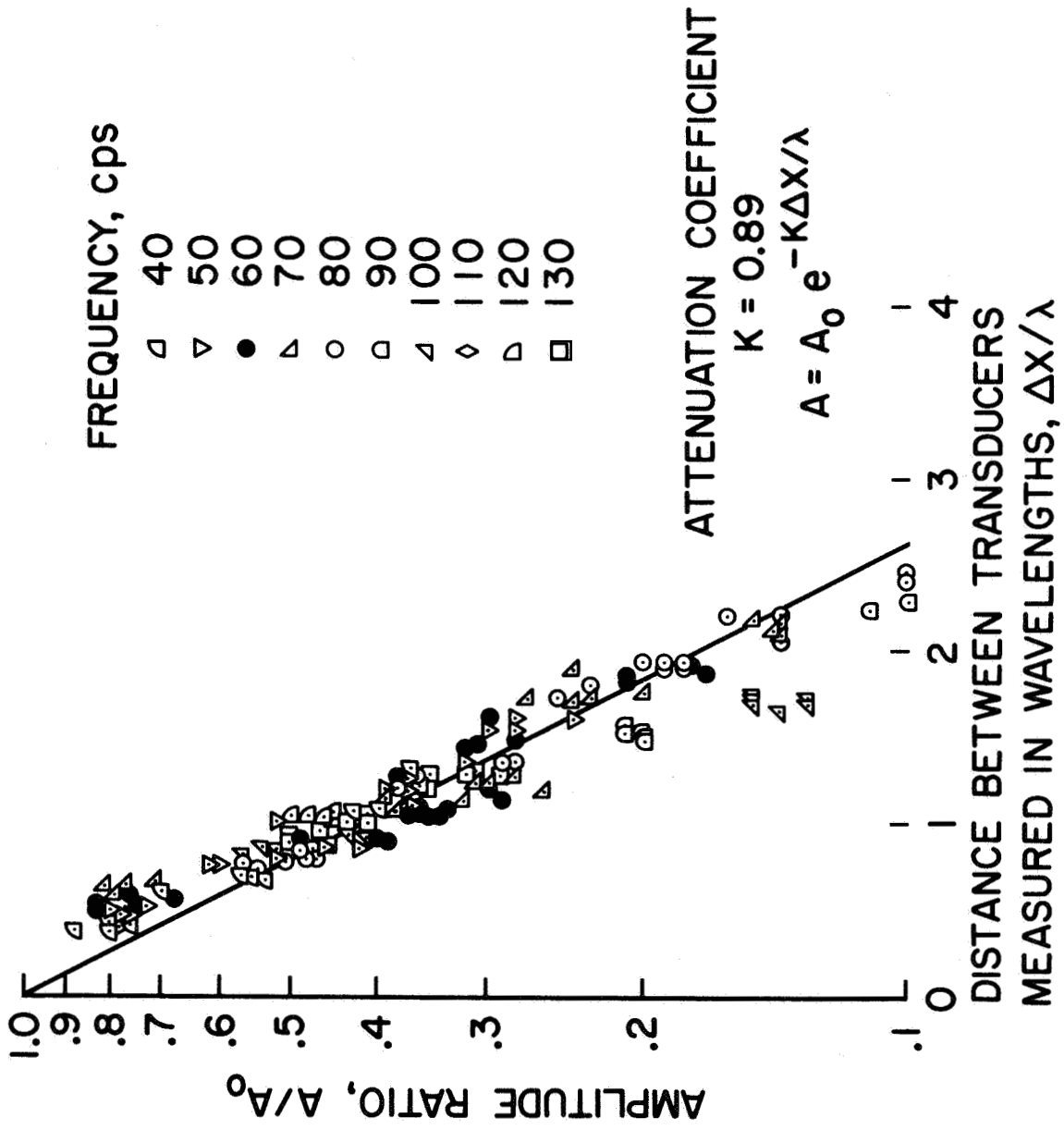

Figure 12. Attenuation of waves corresponding to dispersion data given in Figure 11. $k = .89$

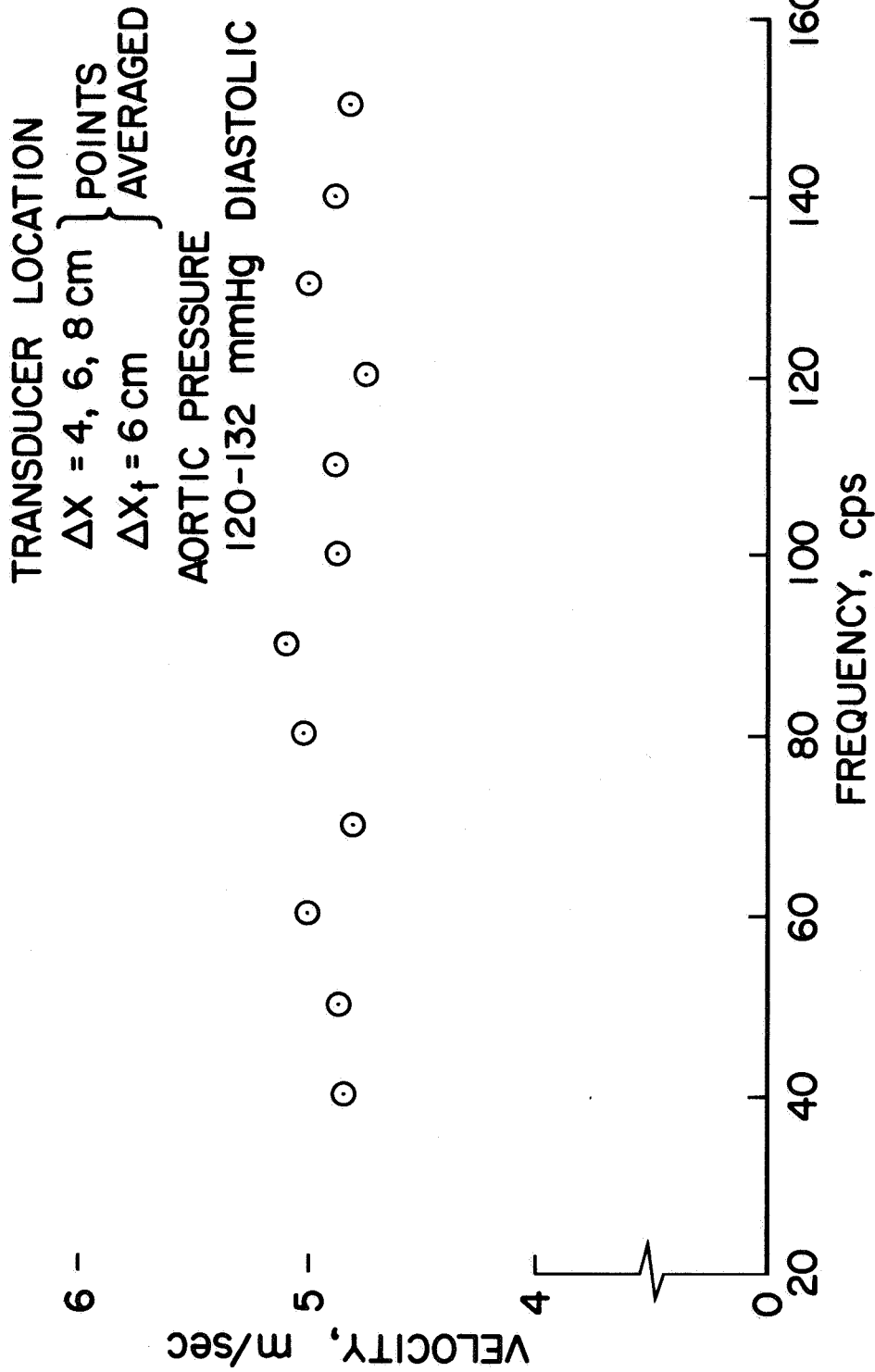

Figure 13. Dispersion curve for waves generated during diastole at a pressure between 120 and 132 mm Hg. ΔX_t denotes the distance between the proximal transducer and the wave generator. Each point represents an average of 3 to 10 speed measurements of different wave trains at the same pressure levels during diastole. (Exp. #124, May 11, 1967)

TRANSDUCER LOCATION
 $\Delta X = 6 \text{ cm}$ $\Delta X_{\dagger} = 6 \text{ cm}$

FREQUENCY, cps

- ◻ 40
- ▽ 50
- 60
- △ 70
- 80
- ◻ 90
- ◁ 100
- ◇ 110
- ▷ 120
- ◻ 130
- △ 140
- ◻ 150

ATTENUATION COEFFICIENT

$$K = 0.75$$

$$A = A_0 e^{-K\Delta X/\lambda}$$

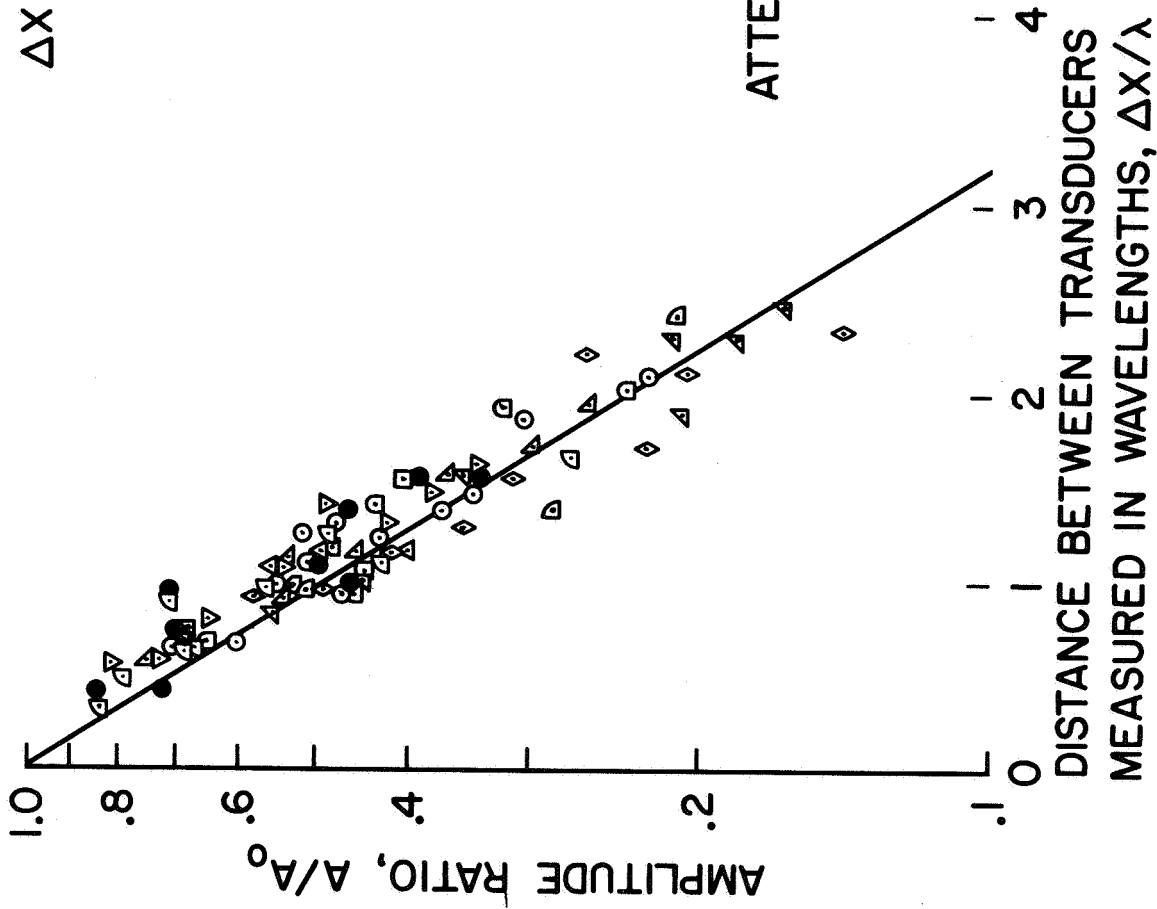

Figure 14. Attenuation of waves corresponding to dispersion data given in Figure 13. $k = .75$.
 (Exp. #124, May 11, 1967)

TRANSDUCER LOCATION
 $\Delta X = 4 \text{ cm}$
 $\Delta X_f = 6 \text{ cm}$
 AORTIC PRESSURE
 75-85 mmHg DIASTOLIC

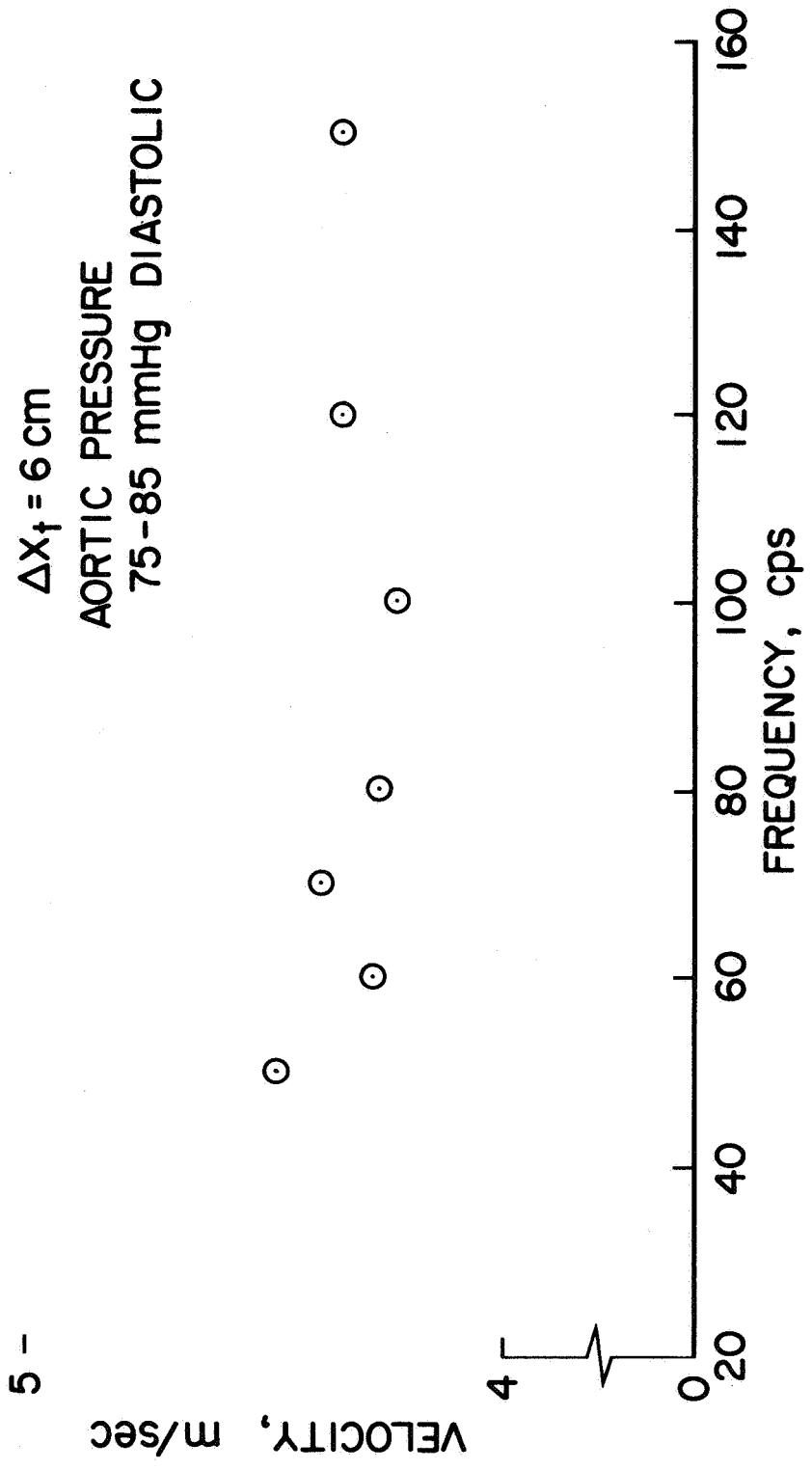

Figure 15. Dispersion curve for waves induced during diastole at a pressure between 75 and 85 mm Hg. Each point represents an average of 3 to 10 speed measurements of different wave trains at the same pressure levels during diastole. (Exp. #133, June 12, 1967)

TRANSDUCER LOCATION
 $\Delta X = 6 \text{ cm}$ $\Delta X_{\uparrow} = 6 \text{ cm}$

FREQUENCY, cps

- ▽ 50
- 60
- △ 70
- 80
- ◁ 100
- ▷ 120

ATTENUATION COEFFICIENT

$$K = 0.75$$

$$A = A_0 e^{-K\Delta X/\lambda}$$

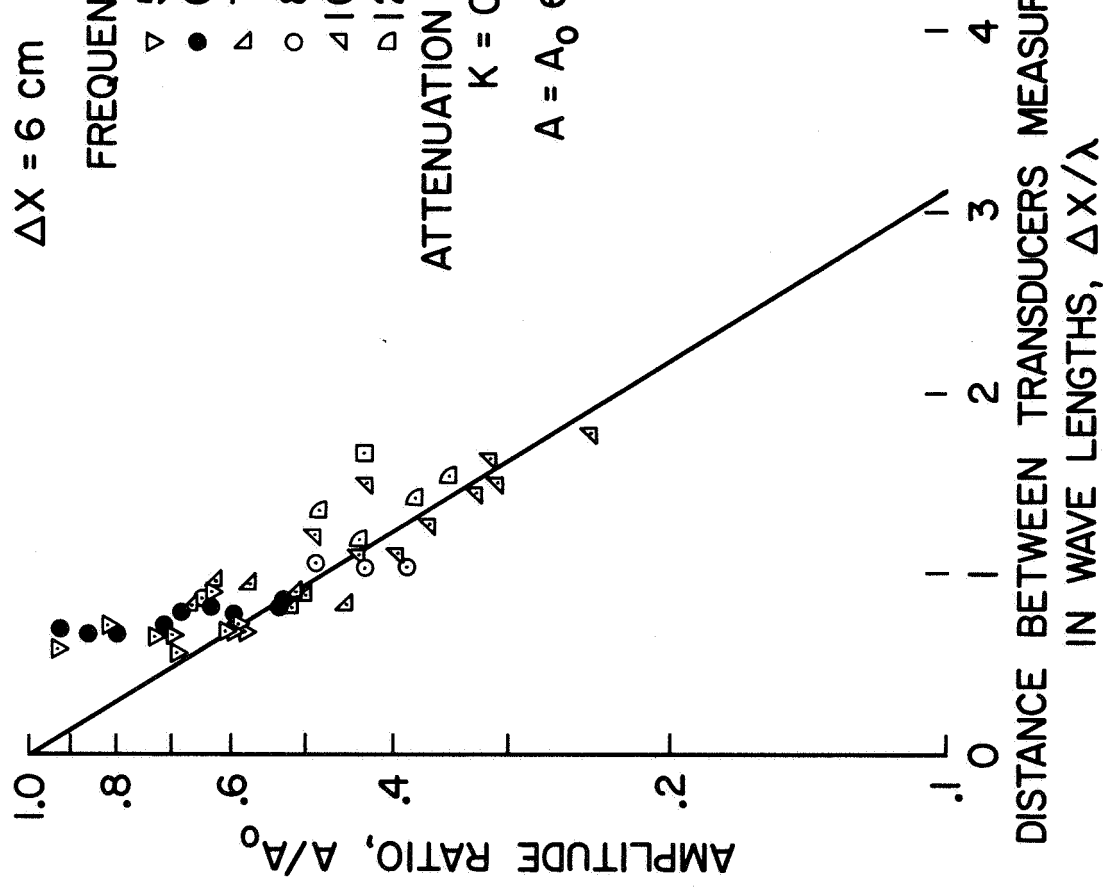

Figure 16. Attenuation of waves corresponding to dispersion data given in Figure 14. $k = .75$. (Exp. #133, June 12, 1967)

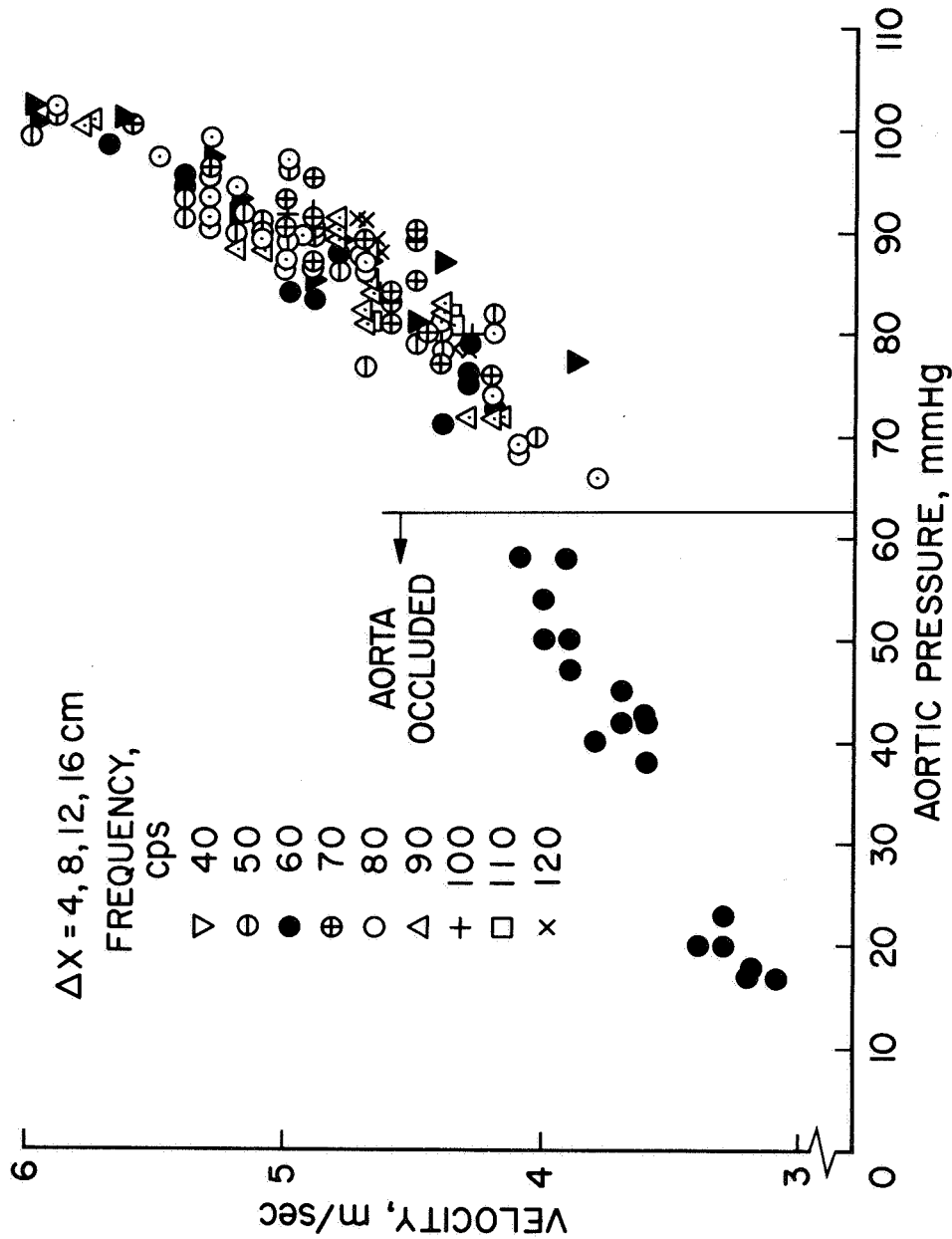

Figure 17. Speed of sinusoidal pressure waves of various frequencies as a function of the instantaneous aortic pressure. The transmission time Δt used to determine the speed was consistently that of a characteristic point in the middle of the train. In this case the diastolic pressure ranged from about 65 to 85 mm Hg while the systolic pressure was between 85 and 100 mm Hg. Data points corresponding to pressures below the diastolic were obtained by occluding the aorta for about 10 sec. Note the steeper rise of the wave speed with pressure between diastole and systole which may be attributed to the stiffening of the aorta with pressure and an increase in mean flow. Since only insignificant mean flow can be present when the aorta is occluded, the data points for 60 cps below the diastolic pressure indicate a change in wave speed with pressure alone. (Exp. #122, May 9, 1967)

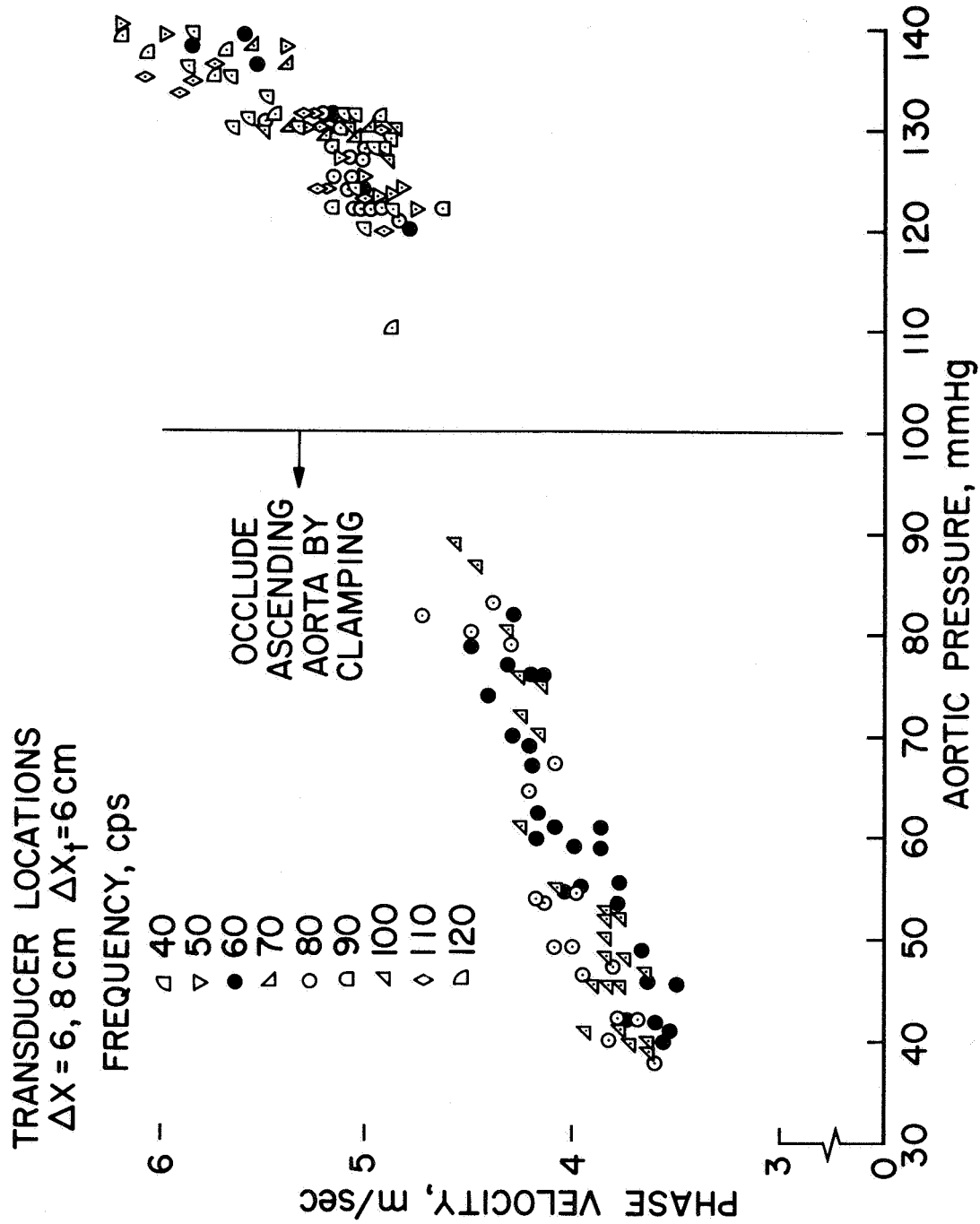

Figure 18. Wave speed variation with instantaneous aortic pressure. The data given here portray essentially the same pattern as those in Figure 17. However, in this experiment the diastolic pressure ranged from about 110 to 130 mm Hg and the systolic from 130 to 140 mm Hg. Data points below 100 mm Hg were obtained by occluding the aorta and using waves with frequencies of 60, 80 and 100 cps. (Exp. #124, May 11, 1967)

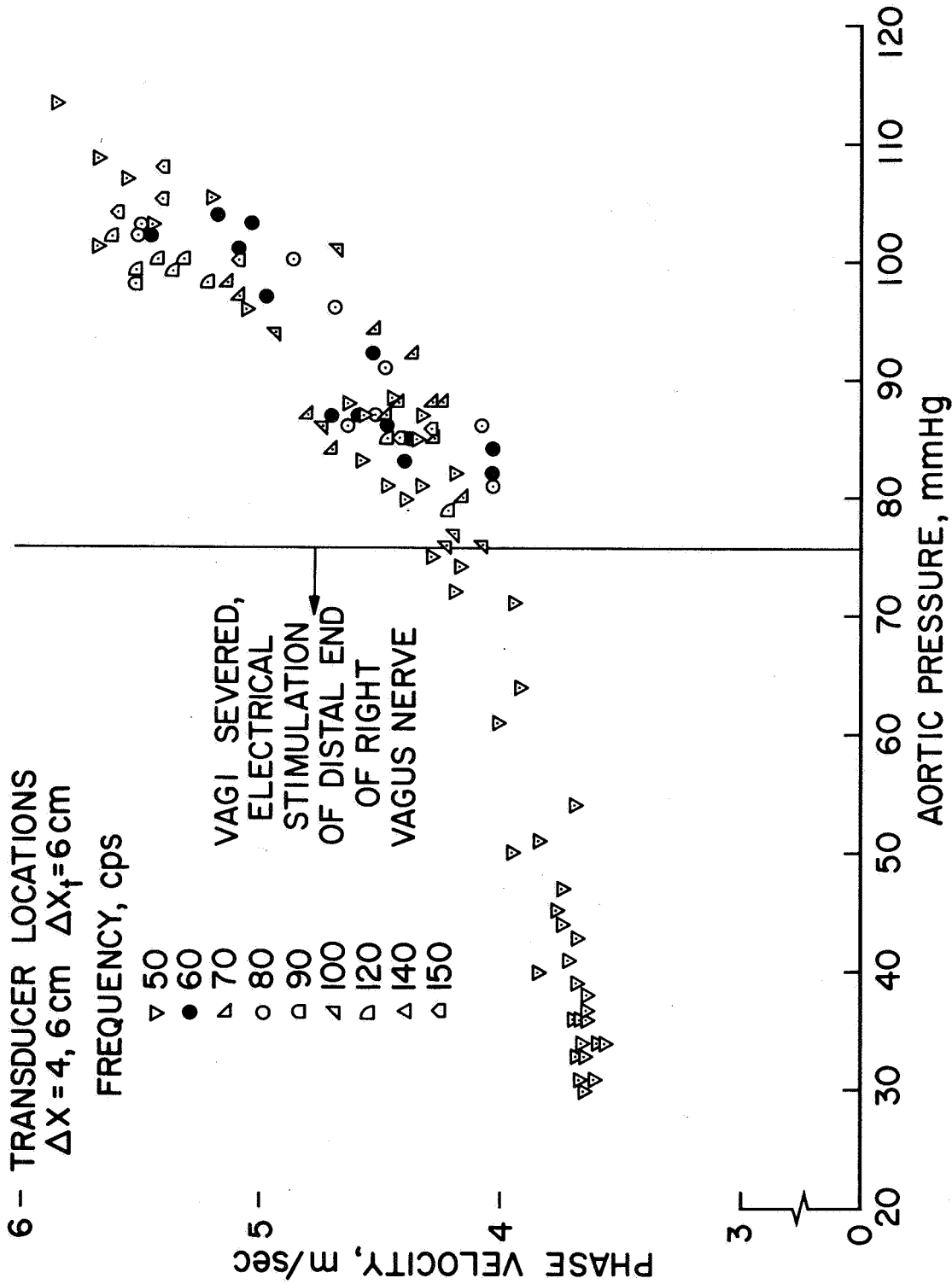

Figure 19. Wave speed variation with instantaneous aortic pressure. The pressure dependence of the phase velocity is similar to that shown in Figures 17 and 18. The diastolic pressure in this case varied from about 75 to 95 mm Hg and the systolic from about 95 to 115 mm Hg. Data points for 50 cps below 75 mm Hg were acquired by intermittently arresting the heart through vagal stimulation. (Exp. #133, June 12, 1967)

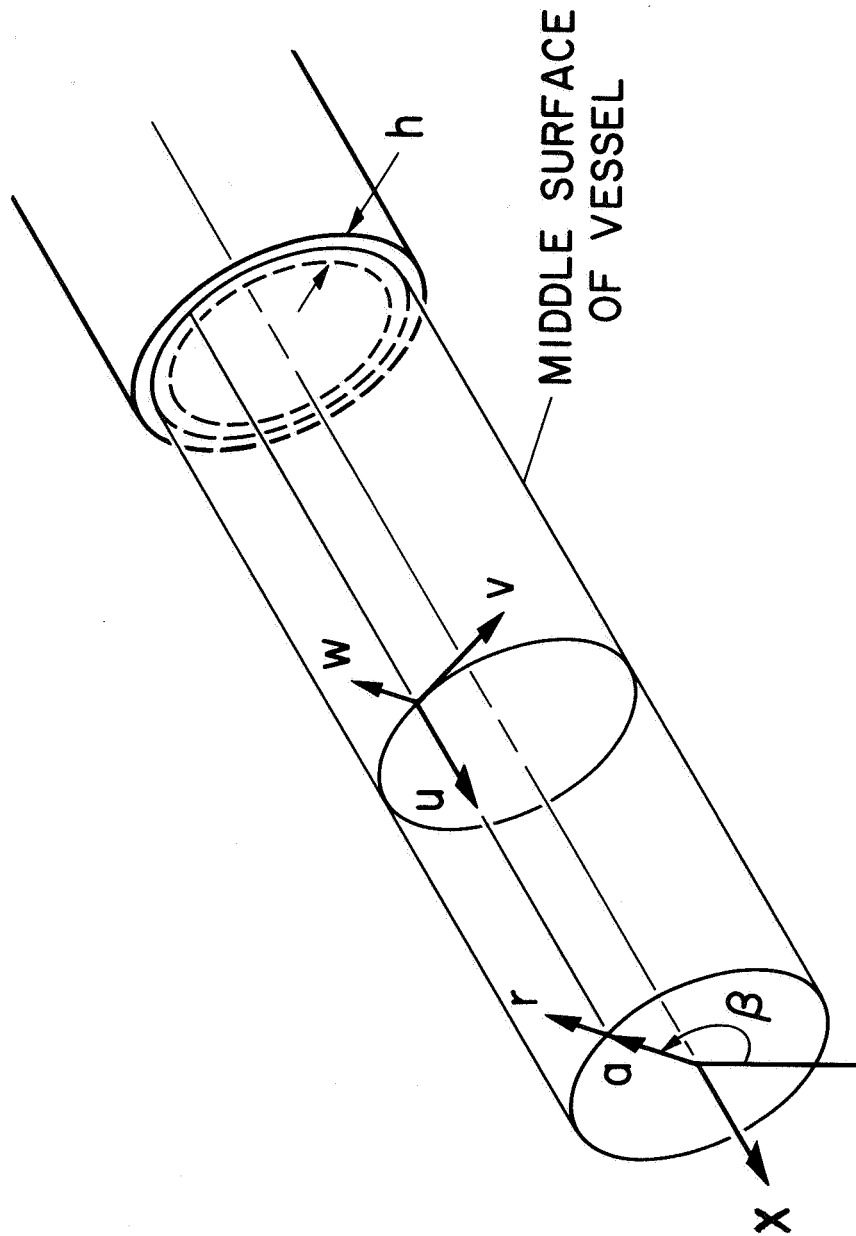

Figure 20. Coordinate system and displacement components u, v, w of an arbitrary point of the middle surface of circular cylindrical shell model for arteries.