

Distributed and Learner Adaptive E-Learning System Using Service Oriented Architecture

N.Ch.S.N.Iyengar, Jaghadeesh.R, Karthik.T.U, Prakash.N.M, Vijayasherly.V
School of Computing Sciences, VIT University, Vellore, Tamil Nadu, India

Abstract

Nowadays, Network and multimedia are the trend of the development of the e-Learning technology. With the rapid development of the network technique and the prevalence of the Internet, e-Learning has become the major trend of the development of international education. With the fast development of Internet, people prefer e-Learning to traditional learning in classroom. It promotes e-Learning consequently. Instead of building an e-Learning system from scratch, it can be assembled by choosing the required functionalities from a set of web services related to e-Learning. Web services eliminate many interoperability issues between components written and running on different hardware and software platforms. This project aims to construct a set of e-Learning web services. With these web services, new e-Learning system(s) can be constructed by choosing the services which are required. The developed web services include assessment, course management, grading and reporting services.

Keywords:

E-learning, web services, tutoring system, adaptive learning.

1. Introduction and Background

The emergence of the internet had great impact on E-learning due to the fact that it is an effective and economical medium for making information available to dispread individuals. Especially, it has radically changed the way in which people learn, teach and train. Today, learning content can be made available even in remote places and without the need to travel to the site where content is delivered. E-learning systems have been topics of increasing interest in recent years. The number of users who are interested in E-learning increases daily. These users have many different interests and objectives, and they will need to access to a huge amount of information. Learners vary significantly in their prerequisites, their

abilities, their goals for approaching a learning system, their pace of learning, their way of learning and time and money they are able to spend on learning. Therefore, a successful system will be one that addresses all issues for all type of users across the world. Such a system should be scalable, available, interoperable, extensible, and adaptable, and indeed, it should be based on novel technologies. Since such systems are very huge, many organizations and institutes should contribute to the construction of these systems. This way, development costs of these systems will highly decrease. Few administrators have the resources necessary to address E-learning complex issues in a way that enable wide-spread standardize use of the technology across the institutions.

2. Organization

The paper is structured as follows. In section 3, the related work is presented. In section 4 E-learning system with learner adaptive capability using web services is proposed. In section 5, the proposed system's architecture is presented.

3. Related Work

One of the main objectives of E-learning systems is to make information accessible to any type of users. E-learning systems consist of complex activities. Current efforts for the next generation E-learning architectures are aiming for a transition from E-learning as an integrated, centrally controlled system to a dynamic configurable federation of educational services and information collections. Treating all systems in the E-learning platform as services that deliver some utility to other services is the fundamental principal behind the service level abstraction. Therefore, developers adapt their

systems to novel technology trends and developments including technologies like Web services and the Grid as well as new paradigms like Peer-to-Peer networking and Service oriented architectures. So, currently, most of E-learning systems are being designed based on client/server, peer to peer; and recently Web Services architectures [1].

In the recent years there has been a shift in trend in the field of e-learning. This is mainly because the apotheosis of individualized learning cannot be achieved in a massive scale. This is mainly because the target population is very diverse and the diversity in educational content and learning activities. A learning environment is considered adaptive if it is capable of all the following.

- Monitoring the activities of its users; interpreting these on the basis of domain specific models.
- Inferring user requirements and preferences out of the interpreted activities and appropriately representing these in associated models [3].
- Acting upon the available knowledge on its users and the subject matter at hand, to dynamically facilitate the learning process [2].

4. Proposed System

The E-learning system proposed basically differs from the others because of the use of web services. Web services are very useful when the implementation of different systems in different environment have to work together. Web services are of two types: RPC based and XML based. Web services built on XML based standards has a lot of benefits over the other web services that are based on RPC. The RPCs' are platform dependent but the web services built using the XML standards are platform and language independent. With this advantage you can use it for communication between any types of application that resides on any platform. The E-learning system proposed can be used in such a way that the course materials and the questions used for quiz can be shared between organizations. The system will suit any group of organizations that agrees to share the courses they created. These sort of E-learning systems are helpful in colleges and companies that need to train their employees in common areas. Now, coming to the E-learning system itself, the system is not a new born. It is a hybrid formed by combining different concepts. Those concepts are explained below.

Adaptive Learning Mechanism

The 'Adaptive Learning Mechanism' assists dynamic rendering of course content. The user is provided with the subscribed courses. Each course is divided into lessons. After a particular lesson in a course, a quiz is provided. The organization of the course material can be thought of as a network of wired nodes. The course material displayed to the user shall be personalized with respect to user character to enable him learn the subject in the most effective way and in the shortest possible time. The user shall be directed to the next node by his performance in his current node. The organization of the course material or the movement of the user in the network of the course can be categorized into a 2 dimensional layer system. In Figure 2, where the horizontal dimension would represent the progress of the student towards course completion and the vertical dimension would represent the difficulty level of the lesson.

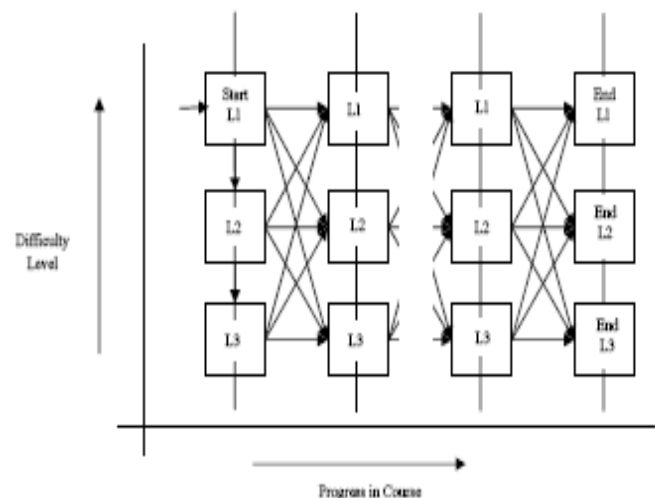

Fig 1: Lessons Network

The nodes that represent the same vertical section contain similar information in terms of concepts, definitions, topics covered etc. The nodes differ in their difficulty levels and have been designed so as to provide the users with same content but in a way that is most understandable to them. The nodes placed higher in the same vertical layer are more advanced and suitably condensed so as to provide the different class of users with the exact amount of information required for them to understand the subject. This is to take into account the fact that different users need different amount of explanations to be able to understand the same topic. According to the difficult level given to the content and stored in an XML format with metadata embedded into the XML file apart from the node content.

The nodes organized along the same horizontal layer have the same difficulty level but differ in the topics that they cover. As the user moves right, he/she progresses towards the completion of the module. Going right can be thought as going to the next chapter of a book. The lessons with varying difficulty levels are hierarchically stored in an XML. Following are the advantages of using XML for storing the course data.

- Course data is independent of the layout of the web page.
- Web services return data in XML format. It is easy to extract the desired lesson from already existing XML file.
- Reusability.

Personalization Learning Model

E-learning system also provides personalization feature, which makes the system user-friendly. This personalization model is implemented to filter out and provide the user only with user interested courses. The courses can be grouped into categories. The student can be interested in any one of the categories. If so, he is given the option to view only the courses from that category only. This simplifies the task for the user to sort out the subjects or courses.

Quiz

Each course is divided into lessons. After a particular lesson in a course, a quiz provided. The quiz is evaluated. The evaluated marks are used for adaptive rendering of the course content using two mathematical models namely Mean Distribution and Uniform Distribution. The questions in the quiz are of different difficulty level. Based on the user performance the following question is dynamically generated. According to the performance of the user in the quiz, the difficulty levels of the following lessons are updated. This helps the E-learning system to divulge as the performance of the user jumps up.

Web Service

The web services which provide basic functionality to the web application are used in this project. These web services render the course content as the request is generated from the client end. Likewise, Quizzes are also rendered in the same manner. Web services provide inter-operability. The courses and the quizzes can be retrieved from any client application that supports the calling of web services.

5. Architecture

The detailed design shows the presence of two modules i.e. E-learning subsystem and E-Courses subsystem. E-learning subsystem acts as the client module. Client module request for subscribed courses and these subscribed courses are rendered by the E-course subsystem through web services.

E-Courses subsystem

E-Courses subsystem is basically a repository of learning courses and web services. These courses are provided as of with user interest. It consists of 4 modules.

- Administrator module

Administrator role is provided with super user privilege. Administrator has sole power to approve a course created by author or to reject it. Administrator can also create course of his/her own.

- Course and Question bank module

This module is the repository of courses and questions of the quizzes created by admin module and author module. These courses are rendered to the E-learning system by using web services. The quizzes are used for providing adaptive content to the users.

- Author module

Author module is similar to the administrator module except for the feature of managing the courses.

- Web services

In generic terms, web services are functionality which is to be provided to the web application irrespective of the working platform. The web service hosted in this project is 'Course' web service which operates only with the e-course module. The web service contains many web methods like GetLesson, GetQuiz, GetCourseByCategory, GetNumberOfTest. Web services also help to provide inter-operability of courses and questions with different educational institute and learning organization.

E-learning subsystem

E-learning system acts as client side web application. This subsystem functions to provide the course content dynamically to the end user. Adaptive Learning Model is included with time taken to complete the lesson of a course and performance of the end user in the quiz as parameters. These parameters help the system to render the course content dynamically to the user from the E-Courses subsystem. E-learning subsystem consists of 3 modules.

- Administrator module

This module is different from the administrator module present in the E-Courses system.

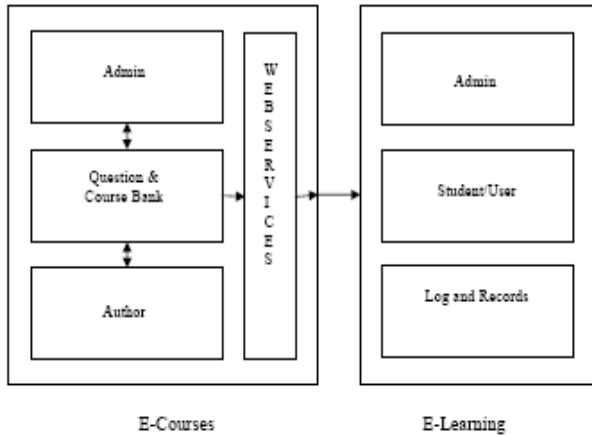

Fig. 2 System Architecture

This module empowers the power of following and denying user access to the courses. This module also has rights to delete the user account.

- Student/User module

This Student/User module is where the client makes registration with the system. While the client makes registration with the E-learning system, they are asked for their interest and the courses which they are familiar with. With this information, the user subscribes for the courses of his/her interest. While subscriptions are made, insinuations are provided for better and efficient learning to take place.

- Logs and Records module

This module basically consists of database(s). This is the module for keeping track of current courses subscription of a particular user, level of the course and course completed status. It also maintains records related to the quiz and the courses which the user knew and courses for which the user has registered for.

6. Conclusion and Future Work

Due to the discrepancy resulting from the essential difference among different students, meagre interactivity and the simplex pattern of current E-learning system, students can't learn according to their needs actively, which lead to inefficient learning results. We have developed a service-oriented architecture along with personalization model and adaptive learning mechanism for E-learning that would increase interoperability, reusability, scalability, customization and interactivity in a heterogeneous E-learning environment. Using web services it is easy to program and maintain services at the server-end.

The number of aspects taken into account for adaptive learning is less in this paper. But, in the near future we would like to add more aspects like themes and varying graphic modes. User Interface can be made more appealing such as by using AJAX. Email and Chatting Facilities can be provided using advanced API available in the market.

7. Acknowledgement

We would like to thank Dr. M. Khalid, Director, School of Computing Sciences, VIT University, for supporting my endeavor to successfully complete my project. We are grateful to our respected Chancellor Dr.G. Vishwanathan, Pro -Chancellors , Mr. Sekar Vishwanathan and Mr. G.V. Selvam, Vice-Chancellor Dr.D.P.Kothari, Pro Vice-Chancellor Dr. A. Anand Samuel for providing us with all the facilities that were required for this project.

8. References

- [1] Moon Ting Su, Chee Shyang Wong, Chuak Fen Soo, Choon Tsun Ooi, Shun Ling Sow "Service-Oriented E-Learning System" IEEE, 2007.
- [2] N.Ch.S.N.Iyengar, Aditya Chopra, Devang Negandhi, Soumith Chintala "Frame Based Intelligent Tutoring System with Weighted Attributes and Adaptive Hypermedia " proceedings of e-CASE, 2009, Singapore, Jan 8-10.
- [3] Xuemin Zhang "Research on Personalized E- Learning Model" proceedings of ISECS International Colloquium on Computing, Communication, Control, and Management, 2008.