

2006

## Distributed Wireless Optical Communications for Humanitarian Assistance in Disasters

Muhsen Aljada  
*Edith Cowan University*

Kamal Alameh  
*Edith Cowan University*

Khalid Al-Begain  
*University of Glamorgan, Wales*

Follow this and additional works at: <https://ro.ecu.edu.au/ecuworks>



Part of the [Engineering Commons](#)

---

This is an Author's Accepted Manuscript of: Aljada, M. , Alameh, K. , & Al-Begain, K. (2006). Distributed Wireless Optical Communications for Humanitarian Assistance in Disasters. Proceedings of Third IEEE International Workshop on Electronic Design, Test and Applications DELTA 2006. (pp. 321-326). Malaysia. IEEE Computer Society. Available [here](#)

© 2006 IEEE. Personal use of this material is permitted. Permission from IEEE must be obtained for all other uses, in any current or future media, including reprinting/republishing this material for advertising or promotional purposes, creating new collective works, for resale or redistribution to servers or lists, or reuse of any copyrighted component of this work in other works.

This Conference Proceeding is posted at Research Online.  
<https://ro.ecu.edu.au/ecuworks/2055>

# Distributed Wireless Optical Communications for Humanitarian Assistance in Disasters

Muhsen Aljada, Kamal Alameh  
Centre for MicroPhotonic Systems, Electron  
Science Research Institute, Edith Cowan  
University, Joondalup, WA, 6027, Australia.

Khalid Al-Begain  
Mobile Computing, Communications and  
Networking Research Group, School of  
Computing, University of Glamorgan,  
Pontypridd (Cardiff), CF37 1DL, Wales, UK

## Abstract

*We propose an optical wireless communication network architecture employing an all-optical central communication unit and optical transceiver units. The network can easily be installed when communication network facilities are partially damaged by a disaster. The network performance is simulated at 1Gbit/s, over 1km under different weather conditions.*

## 1. Introduction

Over the past decade, the world has witnessed series of natural and man-made disasters such as the Katrina storm (New Orleans, USA), Tsunami (Asia), and Twin-Tower bombing (New York, September the 11<sup>th</sup>).

Just after a disastrous event, the partial damage of existing communications terminals, servers, network equipment, and transmission lines prevents effective rescue and network restoration operations. Satellite communications have been used for natural disasters [1]-[4]. However, experience has shown that satellite systems suffer from overloading in areas where disaster relief efforts are underway and that links via satellite are not immune to the impact of extraterrestrial natural events. Wireless communication networks have also been deployed in disasters and are currently considered the most reliable and flexible communications means for disastrous events, owing to their [5],[6].

On the other hand, wireless optical communication networks offer a number of potential advantages over similar radio communications, including broad operation bandwidth (Gbit/s), immunity to interference and jamming, and low cost [7]-[9]. In this paper, we propose a wireless optical communications network consisting of a main hop connecting several nodes utilising broadband free-

space optical transceivers that can easily be installed when the network and computing facilities are partially damaged by a disaster. This system is adaptive, high-capacity (multi-GHz bandwidth), license-free, and can provide short- and long-distance communications. A short distance bi-directional multimedia wireless optical network can be implemented between the disaster information centre and the evacuation places for cooperation with fire defense, health services, and police, while a long distance network is linked to the nearest Internet server and telephone exchanger to restore telecommunication services for offices and houses affected the disaster. The proposed wireless optical communication network is simulated at 1Gbit/s, over 1km, and results show the BER performance under different weather conditions.

## 2. Advantages of Wireless Optical Communications

Wireless optical communication (WOC) have emerged in recent years as an attractive alternative to the conventional radio frequency (RF) approach making the connectivity possible between high-rise buildings and metropolitan and intercity communication infrastructures. WOC provides point-to-point line-of-sight (LOS) links high bandwidth communications between two remote sites. Optical data are transmitted by modulating a laser light in a fashion similar to fiber-optic transmission except that instead of the light being guided within a glass fibre, the light is transmitted through the atmosphere between the transmitter and the receiver. This usually requires that the transmitter and receiver are precisely aligned [10] and maintained by a tracking and pointing system. However, a significant difference between free-space transmission and fibre-optic transmission is the predictability of the attenuation of optical fibres in comparison to the unpredictable atmospheric

attenuation. For example, the atmospheric attenuation can vary from 0.2 dB/km in exceptionally clear weather conditions to a few hundreds of dB/km in a very dense foggy weather. This includes effects such as medium attenuation, scattering, and scintillation, which can reduce the link availability and degrade the burst error [11]. Therefore, in designing an optical wireless link it is always desirable that the transmitter power can be adjusted to compensate for the weather-dependent propagation loss.

### 3. Proposed WOC Architecture

Natural catastrophes such as floods, earthquakes, and hurricanes, and man-made terrorism, can create widespread devastation and communication with outside world can be totally destroyed. Disaster response and recovery require timely interaction and coordination in order to save lives, where the communication infrastructure is no longer operational. An important role in this effort must be played by a reliable, high bandwidth, license free and easy to construct wireless communication network.

Figure 1 shows the proposed wireless optical communications architecture, which provides two types of communication services, namely:

1. Short distance communications between the Disaster Information Centre and the evacuation areas constructed using an all-optical central unit linked to many optical transceivers, whereby the Disaster Information Centre gathers and multicasts information from/to the evacuation areas and cooperates with the fire defense, hospitals, and the police.
2. Long distance communications for restoration of telecommunication services between the disaster area and the telephone network infrastructure.

A line-of-sight (LOS) wireless optical communications link is implemented using a telescope-like transceiver operating at 1550 nm, as shown in Figure 2. The optical transmitter transmits coded voice and data streams using on off keying (OOK) modulation. The optical receiver uses an optical bandpass filter to block most of the background light. The received optical signal is amplified by an optical amplifier and filtered by an optical bandpass filter before it is detected by avalanche photodetector (APD). The photodetected signal is demodulated and the data is recovered using standard electronic signal processing.

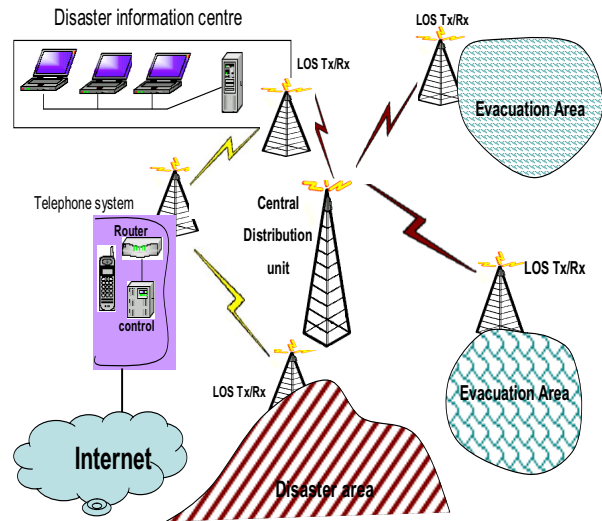

Figure 1. Proposed wireless optical communications architecture

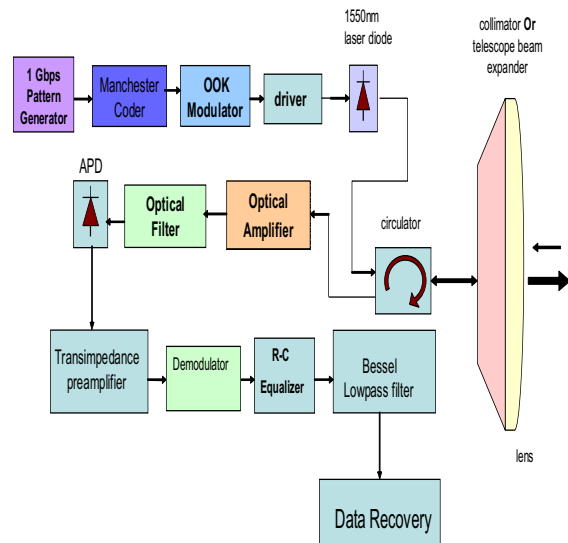

Figure 2. Wireless optical transceiver architecture

An optically-transparent central distribution unit, shown in Figure 3, is deployed to receive optical signals from an LOS transceiver and route them to a local transceiver terminal for subsequent distribution to another remote LOS transceiver unit. An optical signal received by the central distribution unit is optically filtered before it is coupled into a single-mode fibre using an optical fibre concentrator. Then, the signal is amplified, filtered again, and equally split into all transceiver terminals for subsequent multicasting to the LOS nodes. The optical signal is amplified before it leaves the distribution unit to compensate for the

splitting loss and the optical losses of the various components.

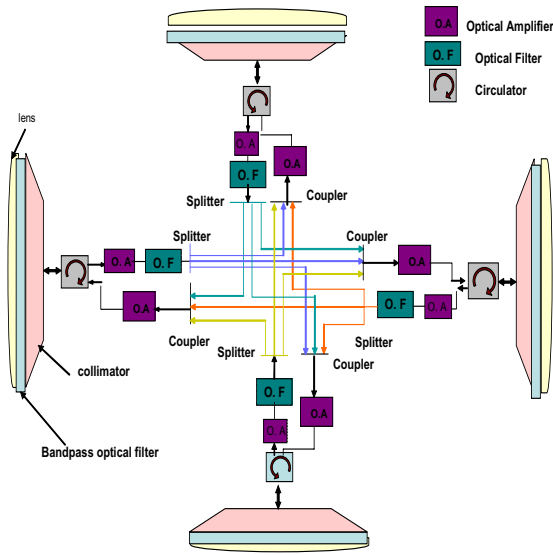

Figure 3. Central distribution unit architecture.

#### 4. Simulation results

The OptiSystem software simulation package has been used to prove the concepts of the proposed wireless optical communication network architecture. The network is simulated using Non-Return to Zero On-Off Keyed (NRZ-OOK) 1Gb/s 1550nm laser transmitters for free-space communications over 1 km span. The attenuations corresponding to different weather conditions are shown in Table 1, and the power budget for a clear weather condition is shown in Table 2.

Table 1. Attenuation for various weather conditions

Weather condition	Attenuation (dB/km)
Clear weather	1
Rain	5
Snow	20
Fog	100

Table 2. Power budget

Laser output power	20dBm
Tx optics loss	6dB
Distribution Node loss	6dB
Rx coupling loss	4dB
Attenuation loss	1 dB (clear weather)
Received power	3dBm

Figure 4 shows the bit error rate (BER) versus the received optical power at the destination, under

different weather conditions. The input transmitted power was assumed to be +20 dBm. Also shown are the eyes diagrams corresponding to different weather conditions. An Avalanche Photodetector (APD) was used in the simulation, which has bandwidth of 11 GHz and a responsivity 0.92 A/W.

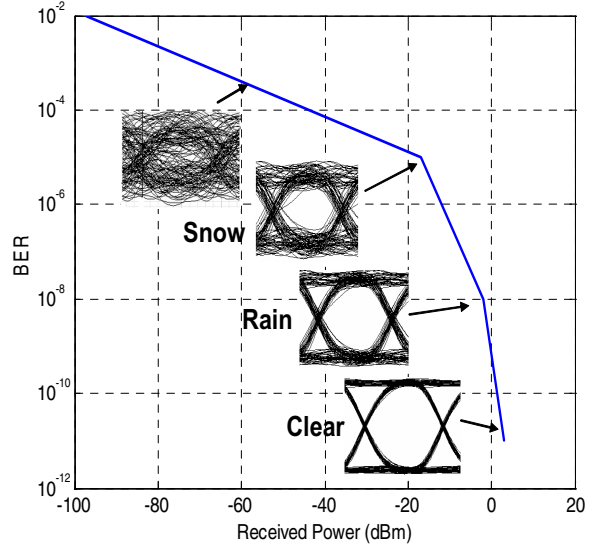

Figure 4. BER versus received power for different weather conditions.

It is evident from Figure 4 that the highest performance can be achieved during clear weather conditions, where an optical power of 3dBm is received leading to a BER of  $10^{-12}$ . For rain conditions, the received power is -1 dBm and the maximum attained BER is  $10^{-10}$ . For snow conditions, an acceptable BER performance of  $10^{-9}$  can be attained. However, the performance is dramatically degraded in fog conditions; a BER of only  $10^{-3}$  can be achieved.

Figure 5 shows the BER versus the transmitted optical power for different weather conditions (attenuations). To achieve a BER of  $10^{-9}$ , the transmitted powers for a clear, rainy and snowy weathers are 15, 20, 30 dBm, respectively, whereas it is difficult to achieve it in foggy conditions. This transmitted power is impractical and limits the use of the proposed wireless optical communication networks to adequate weather conditions.

To overcome the limitations of the network in fog conditions, a hybrid RF/WOC can be employed, where RF links are established at slightly lower data rates in fog-obscured conditions (when FSO links fail).

In addition, by implementing a tracking system to maintain continuous alignment between the transmitter and the receiver the coupling loss can significantly be reduced.

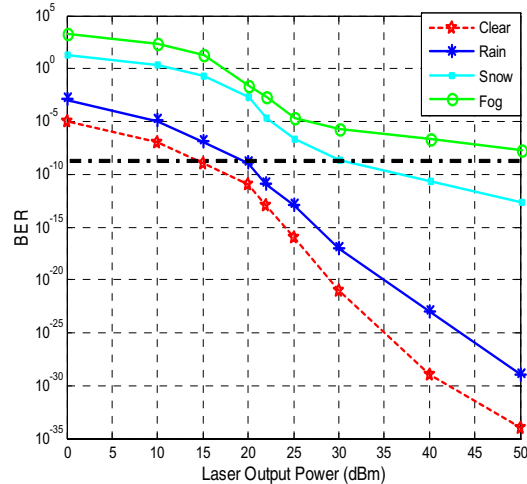

Figure 5. BER versus transmitted power for different weather conditions.

## 5. Conclusion

We have proposed optical wireless communication system architecture constructed using an all-optical central unit and optical transceivers, that can easily installed when the communication network facilities are partially damaged by a disaster. We have compared the system performance under different weather conditions. The system was simulated at 1Gbit/s, over 1km.

## References

[1] V. Garshnek, K. Shinehi and F. M. Burkle, "Disaster Assessment and Satellite Communication: On The threshold of a New Era", *Space Policy*, vol. 14, no. 4, 1998, pp. 223-227.

[2] A. E. Hancock, "VSATs answer the Call", *Sat. Comm.*, vol. 23, no. 11, 1999, pp. 22-26.

[3] O. Lundberg, "INMARSAT: Looking Beyond the Maritime Community", *Telecom Policy*, vol. 7, no. 3, 1983, pp. 192-194.

[4] R. Holdaway, "Is Space Global Disaster Warning and Monitoring Now Nearing Reality", *Space Policy*, vol. 17, no. 2, 2001, pp. 127-132.

[5] H. Asahi, K. Takahata, "Recovery protocol for dynamic network reconstruction on disaster information system," in *Proc. IEEE Advanced Information Networking and Applications*, vol. 2, 2004, pp. 87 – 90.

[6] U. Varshney and R. Vetter, "Emerging Mobile and Wireless Networks", *comm. Assoc. Comp. Mach.*, vol. 43, no. 6, 2000, pp. 73-81.

[7] X. Zhu and J. M. Kahn, "Performance Bounds for Coded Free-Space Optical Communications through Atmospheric Turbulence Channels", *IEEE Trans. Commun.*, vol. 51, no. 8, 2003, pp 1233-1239.

[8] M. Razavi, and J. H. Shapiro, "Wireless Optical Communications via Diversity Reception and Optical Pre-amplification", *IEEE Trans. Wireless Commun.*, vol. 4, no. 3, 2005, pp 975- 983.

[9] M. Aharonovich, S. Arnon, "Performance improvement of optical wireless communication through fog with a decision feedback equalizer", *J. Optical Society of America*, vol. 22, no. 8, 2005, pp 1-9.

[10] D. C. O'Brien, G. E. Faulkner, E.B. Zyambo, K. Jim, D.J. Edwards, P. Stavrinou, G. Parry, J. Bellon, M.J. Sibley, V.A. Lalithambika, V.M. Joyner, R.J. Samsudin, D.M. Holburn, R.J. Mears, "Integrated Transceivers for Optical Wireless Communications", *IEEE J. Selected Topics in Quantum Electronics*, vol. 11, no.1, 2005, pp. 173- 183.

[11] X. Zhu, J. M. Kahn, "Pairwise codeword error probability for coded free-space optical communication through atmospheric turbulence channels", in *Proc. IEEE Conference on Communications ICC*, vol.1, 2001, pp. 161 – 164.