

# DNA sequence variation of the mitochondrial control region among geographically and morphologically remote European brown trout *Salmo trutta* populations

L. BERNATCHEZ, R. GUYOMARD\* and F. BONHOMME

Laboratoire Génome et Populations, (CNRS URA 1493), Université Montpellier II, 34095 Montpellier and \*Laboratoire de Génétique des Poissons, INRA, 78352, Jouy-en-Josas, France

## Summary

Throughout its natural range, the brown trout *Salmo trutta* L. exhibits a complex pattern of morphological and life-history variation. This has led to considerable taxonomic confusion, hampering the understanding of the evolutionary history of the species. To document the phylogenetic relationships among morphologically and geographically remote brown trout populations across western Europe, we determined the DNA sequence variation in segments of the mitochondrial control region for 151 individuals representing 24 populations. DNA was prepared for double-stranded sequencing by the polymerase chain reaction (PCR). Twenty-one variable nucleotide positions within a 640-bp fragment surveyed defined 12 genotypes differing by a mean of 7 nucleotide substitutions (range 1–12). Five major phylogenetic assemblages differing by mean sequence divergence estimates of 0.96 to 1.44% were identified. These groupings exhibited a strong spatial partitioning but lacked congruence with either ecological or morphological differentiation. Complete mitochondrial DNA (mtDNA) monomorphism across all Atlantic basin populations contrasted with the high interdrainage genetic diversity observed in more southerly populations. This study exemplified the usefulness of mitochondrial DNA sequence analysis for estimating phylogenetic relationships within *S. trutta* populations.

*Keywords:* control region, mitochondrial DNA, phylogeography, polymerase chain reaction, *Salmo trutta*

Received 4 April 1992; accepted 7 July 1992

## Introduction

The brown trout *Salmo trutta* L. is a native salmonid species from Eurasia and North Africa. Its natural range extends from northern Norway and the north-eastern part of Eastern Russia southward to the Atlas Mountains of North Africa. From west to east, its range spans from Iceland to the Aral Sea affluents (MacCrimmon & Marshall 1968; Behnke 1986). The brown trout is composed of numerous, distinct geographic forms (Blanc *et al.* 1971). It also exhibits extreme phenotypic diversity and considerable life history variation within a geographical region, including specializations for anadromous, fluvial and lacustrine modes of life. This has led to considerable taxonomic confusion which has

hampered the understanding of the evolutionary history of the species. For instance, more than 50 different Linnean species have been described over the last two centuries based on variation in the species currently recognized as *Salmo trutta* (Behnke 1986).

Several studies have demonstrated heritability for some morphological and meristic characters in environmentally controlled conditions (e.g. Chevassus, Blanc & Bergot 1979; Blanc, Poisson & Vibert 1983; Krieg, 1984; Skaala & Jorstad 1987, 1988). However, it is generally recognized that the exceptional level of phenotypic plasticity that characterizes brown trout and most salmonids limits the usefulness of morphological characters in resolving phylogenetic relationships (Behnke 1972).

Over the past decade, a better understanding of genetic differentiation in brown trout has been obtained through

Correspondence: Louis Bernatchez, INRS-Eaw, 2800 rue Einstein, suite 105, C.P. 7500, Sainte-Foy (Québec), Canada G1V 4C7.

electrophoretic analysis of allozyme variation (reviewed in Ferguson 1989; Guyomard 1989). These studies described the genetic diversity of trout populations in specific geographic areas (Taggart, Ferguson & Mason 1981; Guyomard & Krieg 1983; Krieg & Guyomard 1985; Ryman 1983; Crozier & Ferguson 1986; Karakousis & Triantaphyllidis 1988; Osinov 1990a), and more specifically, have addressed the following questions;

1. are the different ecological variants found in separate drainages derived from a single common ancestor, i.e. are they monophyletic in origin? (Guyomard *et al.* 1984; Osinov 1984; Skaala & Nævdal 1989; Hindar *et al.* 1991); and

2. do the distinction of geographical forms and/or separation of sympatric forms based on phenotypic differences have a phylogenetic basis? (Ryman, Allendorf & Ståhl 1979; Krieg & Guyomard 1985; Hamilton *et al.* 1989; Guyomard 1989; Karakousis & Triantaphyllidis 1990; Osinov 1990b; Ferguson & Taggart 1991).

Collectively, the analyses of allozyme variation have revealed that brown trout represents one of the most highly structured animal species with more than 50% of the total genetic diversity being distributed among populations in some regions (e.g. Krieg & Guyomard 1985). These studies have also been particularly useful in demonstrating that ecological variants are polyphyletic in origin, whereby different ancestors in different drainages have given rise independently to lacustrine, fluviatile, and anadromous forms.

In contrast, limited information was generated on the phylogenetic relationships among geographical forms. In an analysis of French populations, Krieg & Guyomard (1985) clearly demonstrated an important dichotomy between Atlantic and Mediterranean drainage populations and the uniqueness of some Corsican populations. Osinov (1984) also found high levels of divergence between populations from the Baltic Sea, White Sea and Black/Caspian Seas basins. Hamilton *et al.* (1989) proposed that recolonization by two distinct races was partly responsible for the genetic diversity of brown trout in north-western Europe.

Some attempts have been made to carry out an integrated, comprehensive analysis of populations examined in different regions by different laboratories (e.g. Karakousis & Triantaphyllidis 1990). However, problems related to technical differences between laboratories and inconsistencies in allozyme nomenclature cast doubt on the validity and usefulness of such an approach (Ferguson 1989). Furthermore, genetic divergence estimates obtained from allozyme data were based on gene frequency variations and therefore cannot detect phylogenetic relationships among the alleles themselves.

The gathering of such information requires the study of genetic variation at the DNA level, and has been referred

to as phylogeography (Avice *et al.* 1987). This approach has widely been applied to the study of mitochondrial DNA (mtDNA) variation using restriction fragment length polymorphisms (RFLPs) in many groups of animals, including fishes (reviewed in Billington & Hebert 1991). However, the few mtDNA studies involving brown trout were preliminary, being restricted to few fish and populations (Palva 1986; Gyllensten & Wilson 1987; McVeigh & Ferguson 1988; Hynes, Duke & Joyce 1989). These studies suggested that mtDNA variation may not be as extensive as allozyme variation. In this case, a higher degree of resolution may be obtained by examining sequences in the more variable regions of the mitochondrial genome.

The recent introduction of the automation of the polymerase chain reaction (PCR; Saiki *et al.* 1985) allows one to obtain sequence information on specific sections of the genome in large-scale population surveys (Vigilant *et al.* 1989; Meyer *et al.* 1990; Thomas *et al.* 1990; Carr & Marshall 1991; McVeigh, Bartlett & Davidson 1991; Smith & Patton 1991; Patton & Smith 1992). Studies of mammalian DNA sequence variation have revealed that the most variable regions of the mitochondrial genome were located in the non-coding, control region (D-loop; e.g. Vigilant *et al.* 1989). However, there are currently few data available to confirm if this also holds true in lower vertebrates, particularly fishes.

In this paper, we studied the DNA sequence variation in segments of the mitochondrial control region homologous to those reported as hypervariable in mammals to document the phylogenetic relationships and the distribution of mtDNA genetic diversity in morphologically and geographically remote brown trout populations across western Europe.

## Materials and methods

### Sample collections

A total of 151 fish was collected in 1990 and 1991 from 24 different populations in western Europe (Table 1). Samples consisted of fresh, frozen, or ethanol-preserved liver or ovarian tissues shipped by collaborators to the laboratory. Unless otherwise indicated in Table 1, samples were obtained from populations apparently not stocked with domestic strains of brown trout.

### DNA extractions

For fresh tissue samples, mtDNA was purified according to Bernatchez *et al.* (1988). For other samples, total DNA was obtained from digestion of 100 mg of minced tissue in 1 ml of buffer (50-mM Tris, pH 8.0; 100-mM EDTA, pH 8.0;

**Table 1** Origins of fish populations, sample sizes (*n*), and absolute frequency distribution of 12 genotypes among 151 *S. trutta* mtDNA sequences. Basin: At; Atlantic, Da; Danube, Me; Mediterranean, Ad; Adriatic. Morph refers to the subspecies name currently assigned in the literature. Morphs *trutta*, *lacustris* and *fario* refer to anadromous, lacustrine, and fluvial ecological forms, respectively. Morphs *letnica*, *carpio*, *macrostigma* and *marmoratus* refer to morphologically distinct geographic forms. Asterisks mark populations for which samples were obtained in a small affluent of the given waterbody. Redon R., Aubonne R., Bresle R., Chisone R. and Pellice R. populations are currently stocked with domestic strains of Atlantic origin. Tes R. has been stocked until four years ago with domestic strains maintained in Italy. Gurk R. sample was obtained from hatchery strains originating from local native fish

Population	Basin	Morph	<i>n</i>	Sequences												
				At1	At2	Da1	Da2	Me1	Me2	Ad1	Ad2	Ad3	Ma1	Ma2	Ma3	
(a) Splusk R, Poland	At	<i>trutta</i>	4	4												
(b) Swibno R., Poland	At	<i>trutta</i>	2	2												
(c) Bogstad L., Norway*	At	<i>lacustris</i>	7	7												
(d) Dalalven R., Sweden	At	<i>fario</i>	8	8												
(e) Vlada R., Czechoslovakia	At	<i>fario</i>	8	8												
(f) Saar R., Switzerland	At	<i>fario</i>	8	8												
(g) Bresle R., France	At	<i>fario</i>	8	8												
(h) Elorn R., France	At	<i>fario</i>	8	8												
(i) Eulenbach R., Germany	Da	<i>fario</i>	6	4			2									
(j) Gurk R., Austria	Da	<i>fario</i>	5	5												
(k) Bohing L., Yugoslavia	Da	<i>fario</i>	1				1									
(l) Redon R., France	Me	<i>lacustris</i>	3	3												
(m) Aubonne R., Switzerland	Me	<i>lacustris</i>	5	4	1											
(n) Doubs R., France*	Me	<i>fario</i>	6						6							
(o) Tes R., France	Me	<i>fario</i>	8	1				4	2							1
(p) Dranse R., France*	Ad	<i>fario</i>	8							7	1					
(q) Ohrid L., Yugoslavia	Ad	<i>letnica</i>	8							8						
(r) Neretva R., Yugoslavia	Ad	<i>fario</i>	2	1		1										
(s) Chisone R., Italy	Ad	<i>fario</i>	8							5					3	
(t) Garda L., Italy	Ad	<i>carpio</i>	8							6					1	1
(u) Toce R., Italy	Ad	<i>marmoratus</i>	8										4		4	
(v) Pellice R., Italy	Ad	<i>marmoratus</i>	8												8	
(w) Vecchio R., Corsica	Me	<i>macrostigma</i>	6						1					5		
(x) Taravo R., Corsica	Me	<i>macrostigma</i>	8											8		

1% SDS, 0.6% Proteinase K) for 16 h at 37°C with constant gentle mixing. The solution was sequentially extracted once each with one volume of phenol, phenolchloroform:isoamyl alcohol (24:1), and chloroform:isoamyl alcohol (24:1). Total DNA was recovered by overnight precipitation in 2.5 volumes of absolute ethanol, and centrifugation at 13 000 r.p.m. for 30 min. DNA was resuspended in 100–300 µl of sterile, deionized water and frozen at –20°C until amplification.

*DNA amplification and sequencing*

Double-stranded PCR amplifications were performed in 50-µl reaction volumes containing 2 units of *Thermus aquaticus* DNA polymerase (Promega), 5 µl reaction buffer (500-mM KCl, pH 9.0; 0.1% gelatin; 1% Triton X-100), 20 pmol (picomole) each of the light- and heavy-strand primers, 6.5-mM MgCl<sub>2</sub>, and 500 µM dGTP, dATP, dTTP and dCTP (Boehringer Mannheim). One microlitre of the DNA preparation was added to the PCR mix. DNA was amplified in a programmable thermal cyler (MJ

Research, USA) using the following profile: one preliminary denaturation at 95°C for 1 min, followed by strand denaturation at 92°C (1 min), annealing at 50°C (1 min), and primer extension at 72°C (1.5 min) repeated for 30 cycles.

The light- and heavy-strand primers were located within the proline and phenylalanine tRNA genes, respectively, allowing amplification of the entire non-coding region (approximately 1 kilobase). The primer located in the proline tRNA gene (L19: 5' CCACTAGCTCCC~~A~~AAGCTA 3') was designed from homologies observed among published fish sequences (Buroker *et al.* 1990; Meyer *et al.* 1990; Johansen, Guddal & Johansen 1990). The other primer (H17: 5' ACTTTCTAGGGTCCATC 3') was designed from homologies between *Gadus morhua* (Johansen *et al.* 1990) and unpublished Arctic charr sequences (S. Johansen, unpublished data).

Amplified DNA templates were purified from residual primers and nucleotides by selective alcohol precipitation (Kreitman & Landweber 1989). Briefly, double-stranded DNA was precipitated in 1.25-M ammonium acetate, 50%

ethanol, and centrifuged for 15 min. DNA pellets were rinsed in 200  $\mu$ l of 70% ethanol, centrifuged for 10 min, and dried under vacuum. Pellets were resuspended in 70  $\mu$ l of sterile, deionized water and extracted once with one volume of phenol. DNA was precipitated and centrifuged a second time in (1.25-M) ammonium acetate and (50%) ethanol. Vacuum-dried pellets were resuspended in 10  $\mu$ l of sterile, deionized water.

Double-stranded DNA sequencing reactions were prepared with the Sequenase kit (Version 2.0, US Biochemical) according to the manufacturer's directions and the following modifications. Thirty picomoles (1.5  $\mu$ l) of either the L19 or H17 primer was mixed with 8.5  $\mu$ l of the purified DNA template. This mixture was denatured by boiling for 3 min and quickly chilled on wet ice. Eight microlitres of reaction mix [1  $\mu$ l of DTT solution, 2  $\mu$ l of reaction buffer, 2  $\mu$ l of labelling mix (diluted 1:4), 0.5  $\mu$ l of  $^{35}$ S-dATP, 0.5  $\mu$ l of Mn buffer 2  $\mu$ l of Sequenase enzyme (diluted 1:5)] was immediately mixed with denatured DNA. Aliquots (3.5  $\mu$ l) of this mixture were immediately transferred to each of the four termination reaction tubes containing 2.5  $\mu$ l of each ddNTP mixture. Sequences were separated on 40-cm, 6% polyacrylamide (19:1 BIS), 7-M urea gels. Electrophoresis was performed at 1100–1200 V constant voltage for either 2–2.5 h or 4.5–5.5 h to obtain the 5' and the 3' ends of the sequence, respectively. The gels were fixed in 10% ethanol:10% acetic acid for 20 min, vacuum-dried onto filter paper at 80°C for 45 min, and autoradiographed with X-ray film (Fuji, RX-L) for 48 to 240 h.

### Sequence analyses

Sequence data were subjected to both distance and character-based analyses using the PHYLIP computer package (Version 3.3; provided by J. Felsenstein, Department of Genetics, SK-50, University of Washington, Seattle, WA 98195, USA). The distance measure used was the estimate of nucleotide substitution calculated under the Kimura 2-parameter model (Kimura 1980) using the program DNADIST. The resulting distance matrix was used to build least-square estimates of the phylogenetic network with unconstrained branch-lengths (FITCH program). For character-based analysis, the sequence data were used to generate phylogenetic trees according to a maximal parsimony criterion using the DNAPARS program (Wagner option). A majority-rule consensus tree was constructed using the CONSENSE program. Trees were rooted using Atlantic salmon (*Salmo salar* L.) as an outgroup, a close relative of the brown trout (Gyllensten & Wilson 1987).

Intra- and inter-population genetic diversity was measured by the maximum likelihood estimation of the average number of nucleotide substitutions per site

within and between populations (Nei 1987). This allowed an estimation of population subdivision at the nucleotide level,  $N_{st}$  (Lynch & Crease 1990). The resulting index gives the ratio of the average genetic distance between genes from different populations relative to that among genes in the population. Extreme  $N_{st}$  estimates of 0 and 1 indicate zero and complete population subdivision, respectively.

## Results

### Sequence variation and diversity of mtDNA genotypes

For all specimens analysed, a minimum of 310 bp could be determined at the 5' end of the control region (Fig. 1). An additional 330 bp were sequenced at the 3' end for one representative of all genotypic variants in order to increase the reliability of the estimate of their phylogenetic relationships (Fig. 1). Both regions sequenced were A-T

#### 5'- end segment

```

Proline tRNA      1          2          3
-----*-----*-----*
AAACTATCCT CTGATTTTC AGCTATGTC AATAACAATT GTTGTACCTT GCTAACCCAA 60

TGTTATACTA CATCTATGTA TAATATTACA TATTATGTAT TTACCCATAT ATATAATATA 120
      4          5
GCATG-TGAG TAGTACATCA TATGTATTAT CAACATTAGT GAATTTAACC CCTCATACAT 180
      6          7
CAGCACTAAC TCAAGGTTTA CATAAAGCAA AACACGTGAT AATAACCAAC TAAGTTGTCT 240
      8 9 10 11      12 13
TAACCCGATT AATTGTTATA TCAATAAAAC TCCAGCTAAC ACGGGCTCCG TCTTTACCCA 300
      * * * * *
CCAACTTTCA

```

#### 3'- end segment

```

CACTTAATAT ATCTCTAAGA TACCCCGGCT TCTGCCGGT AACCCCCCTA CCCCCTACG 60
                                         14
CTGAAGGATC CTTATATCC TGTCAAACC CTAAACCAGG AAGTCTCAA TCAGCGCCAA 120
                                         15
TCITTTTATA TACATTAATG AACTTTTTG CCAATTTTAT AGCATTTGGC ACCGACTACA 180
      16          17
CTATCATTAG CACCACCTTT ATAATTAAAG TATACATTAA TAAAC-TTIT CGCTAAATTT 240
      18          19          20
TATAACATTT AGCACCGACT CCAGTGTGAT TAGCACCTTC TCAATCAAAC ATATAAAGGC 300
      21
CTAGTTGGCG TAGCTTAACT AAAGCATAA
-----*-----*
Phenylalanine tRNA

```

Fig. 1 Sequences for two segments of the mtDNA control region, type At1, from *S. trutta*. The sequences shown are for the light strand. The first sequence (5' end) includes part of the proline tRNA gene. The second sequence (3' end) includes part of the phenylalanine tRNA gene. Asterisks and numbers above mark the 21 variable positions among the 12 brown trout genotypes observed. The sequences presented in this paper (cf. Table 2) have been entered into GeneBank under the accession numbers M97962 to M97987.

**Table 2** Variable nucleotide positions of 12 genotypes resolved among 151 *S. trutta* mtDNAs sequenced. Numbers refer to sequence position in Fig. 1. Nucleotide at each position is given for genotype At1. For other genotypes, nucleotides are given when different from AT1, while identity is indicated by dashes. Asterisks indicate deletions (or insertions)

Genotypes	Variable sites																				
	1	2	3	4	5	6	7	8	9	10	11	12	13	14	15	16	17	18	19	20	21
At1	T	T	C	*	G	T	A	G	A	T	T	G	C	C	T	A	*	T	C	A	C
At2	-	-	-	-	-	-	-	A	G	-	-	-	-	-	-	-	-	-	-	-	-
Da1	C	A	-	-	-	-	-	-	-	G	-	-	-	-	-	G	-	-	T	-	-
Da2	C	A	-	-	-	-	-	-	G	G	-	-	-	-	-	G	-	-	T	-	-
Me1	-	-	-	-	A	-	C	-	-	-	-	-	-	-	C	G	T	C	-	-	-
Me2	-	C	-	-	A	-	C	-	-	-	-	-	-	-	C	G	-	C	-	-	-
Ad1	-	C	-	-	-	-	-	-	-	-	-	C	-	-	-	G	T	-	-	-	-
Ad2	-	C	-	-	-	-	-	-	-	-	C	C	-	-	-	G	T	-	-	-	-
Ad3	-	C	T	-	-	-	-	-	-	-	C	-	-	-	-	G	T	-	-	-	-
Ma1	-	C	-	A	-	-	-	-	-	-	-	A	-	T	-	G	-	-	-	T	T
Ma2	-	C	-	A	-	-	-	-	-	-	-	A	T	T	-	G	-	-	-	T	-
Ma3	-	C	-	A	-	C	-	-	-	-	-	A	T	T	-	G	-	-	-	T	-

**Table 3** Matrix of pairwise percentage sequence divergence estimates (below main diagonal) and observed number of mutational events differences (above main diagonal) between 12 *S. trutta* mtDNA genotypes

Genotype	At1	At2	Da1	Da2	Me1	Me2	Ad1	Ad2	Ad3	Ma1	Ma2	Ma3
At1		2	6	5	9	7	5	6	6	8	8	9
At2	0.32		8	7	11	9	7	8	8	10	10	11
Da1	0.96	1.28		1	11	9	7	8	8	10	10	11
Da2	0.80	1.12	0.16		10	8	6	7	7	9	9	10
Me1	1.44	1.76	1.76	1.60		2	8	9	9	11	11	12
Me2	1.12	1.44	1.44	1.28	0.32		6	7	7	9	9	10
Ad1	0.80	1.12	1.12	0.96	1.28	0.96		1	1	7	7	8
Ad2	0.96	1.28	1.28	1.12	1.44	1.12	0.16		2	8	8	9
Ad3	0.96	1.28	1.28	1.12	1.44	1.12	0.16	0.32		8	8	9
Ma1	1.28	1.60	1.60	1.44	1.76	1.44	1.12	1.28	1.28		2	3
Ma2	1.28	1.60	1.60	1.44	1.76	1.44	1.12	1.28	1.28	0.32		1
Ma3	1.44	1.76	1.76	1.60	1.92	1.60	1.28	1.44	1.44	0.48	0.16	

rich (68%). Twenty-one of the 640 positions in the sequences were variable, involving 26 mutational events (Table 2). Sequence variation was predominantly due to transitions ( $n = 17$ ), followed by transversions ( $n = 6$ ), and single base-pair insertions/deletions ( $n = 3$ ). No large deletions or insertions were observed.

Twelve mitochondrial genotypes were identified among the 151 individuals sequenced (Table 2). Pairwise sequence divergence estimates varied from 0.16 to 1.92% (mean  $\pm$  SD,  $1.20 \pm 0.44\%$ ), implying 1–12 ( $7.5 \pm 2.8$ ) mutational steps between genotypes (Table 3).

**Molecular trees**

The FITCH phenogram revealed five major clusters separated by mean sequence divergence estimates ranging from 0.96% to 1.44% (Fig. 2). Character-based analysis

resolved a total of 16 equally parsimonious trees, requiring a minimum of 26 mutational steps for 21 mutated sites (consistency index = 0.81). The majority-rule consensus tree is presented in Fig. 3. The rooting position was the same in all of the 16 trees and identical to that of the FITCH phenogram. The five clusters resolved in the distance-based analysis were supported in all 16 trees, indicating that they represent phylogenetically distinct groups. However, the branching pattern, except for the position of the root, was non-significant and remained unresolved.

**Geographic distribution of mtDNA phylogenetic groups**

All five phylogenetic groups exhibited a strong geographic pattern of distribution (Fig. 4, Table 1). All individuals from the Atlantic drainage populations were fixed for group IV (genotypes At1, At2). Group IV was

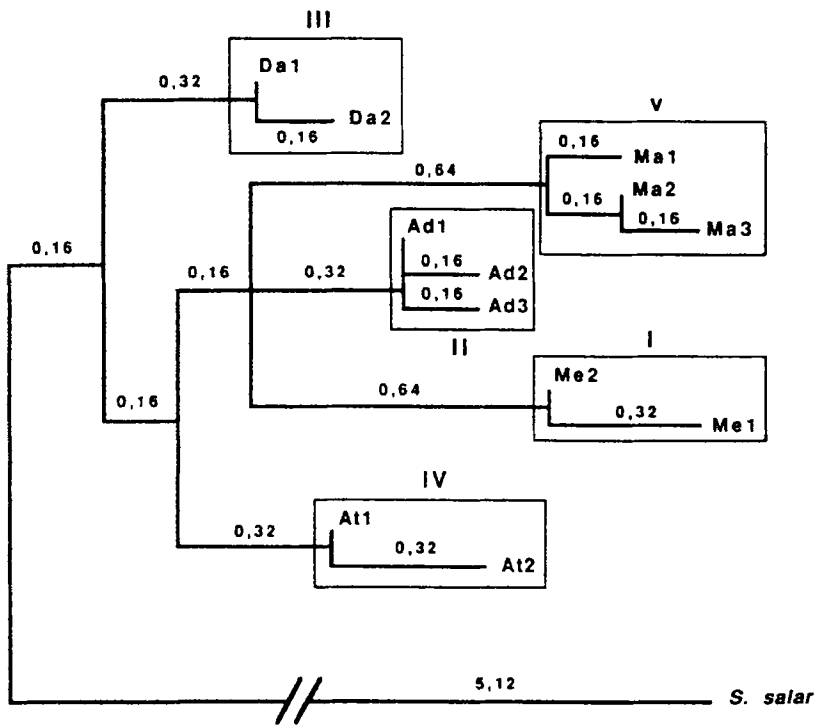

Fig. 2 Unconstrained branch-length phenogram clustering 12 genotypes observed among 151 *S. trutta* mtDNA sequences. Definitions of genotypes are given in Table 2. Branch lengths are given on the tree. *Salmo salar* was used as an outgroup taxon.

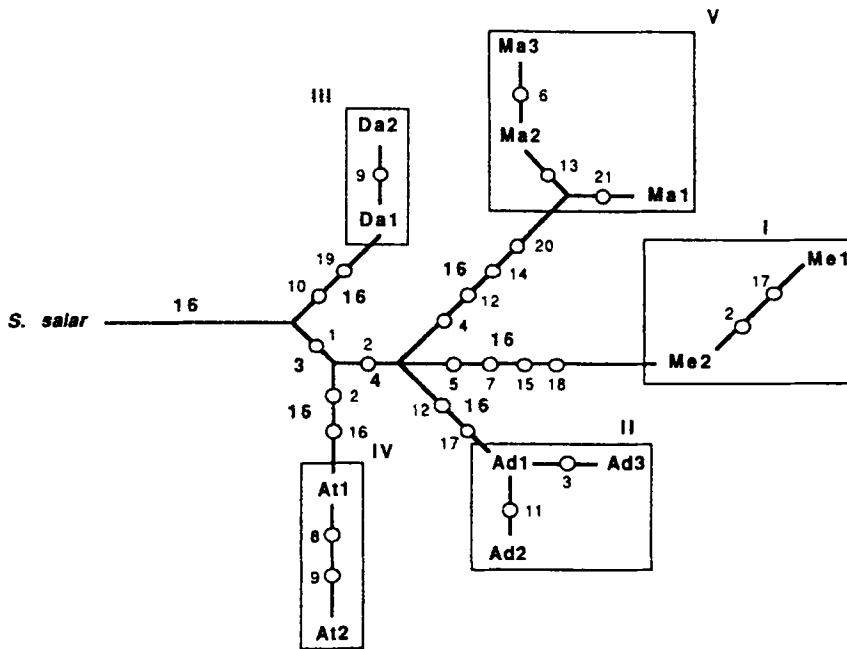

Fig. 3 Majority-rule consensus network resulting from the 16 equally most parsimonious trees found by the MIX program. The network was rooted using *S. salar* as an outgroup. Definitions of genotypes are given in Table 2. Open circles indicate mutational events and small-character numbers refer to the variable nucleotide positions (Table 2). Bold-character numbers refer to the numbers of trees out of 16 in which particular groupings were observed.

also dominating in the Danube drainage. It was observed in a single individual from Adriatic populations and only in some Mediterranean populations currently or previously stocked with domestic strains of Atlantic origin (Table 1). Group III (genotypes Da1, Da2) was confined to the Danube drainage with the exception of one individual from the Neretva River, in the Adriatic basin. Group I

(genotypes Me1, Me2) was confined to Mediterranean populations while group II (genotypes Ad1–Ad3) was only observed among Adriatic and Corsican populations. However, Corsican populations were almost fixed (93% of the fish examined) for genotype Ad3, which was not detected in any continental populations. Group V (Ma1–Ma3) was strictly associated with Adriatic drain-

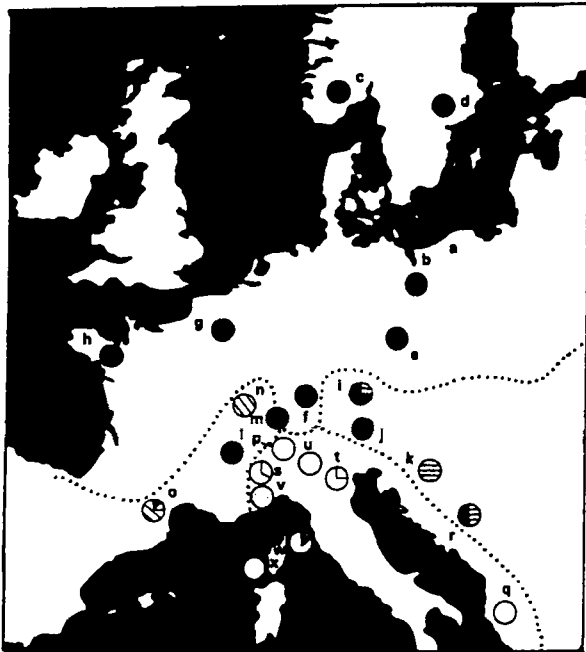

Fig. 4 Geographic distribution of the five phylogenetic groupings among 151 *S. trutta* sequenced mtDNAs resolved in distance-based and character-based analyses: Group I (●), Group II (○), Group III (⊖), Group IV (●), Group V (⊕). Dotted lines delineate major basins.

ages, with the exception of one individual from the Tes River (France) which was known to have been stocked with domestic strains maintained in Italy.

*Levels of congruence in genotypic and phenotypic variation*

No association was observed between mtDNA phylogenetic groupings and the different ecological morphs exhibited in the populations studied (Table 1). For instance, there was no detectable differentiation among anadromous (morph *trutta*), lacustrine (morph *lacustris*) or fluviatile (morph *fario*) populations observed within the Atlantic basin. Conversely, fluviatile or lacustrine populations from Atlantic, Mediterranean and Adriatic drainages were fixed for distinct phylogenetic groups. This clearly indicates that ecological morphs do not represent natural assemblages resulting from monophyletic divergence.

However, some associations were observed between distinct mtDNA genotypes and geographic morphs. For example, all *marmoratus* trout analysed were fixed for mtDNA group V, whereas all but one fish from Corsica (morph *macrostigma*) were fixed for genotype Ad3. In contrast, fish from Ohrid L. (morph *letnica*) were not genetically differentiated, being fixed for genotype

Ad1, which was observed in other morphs from the Adriatic and Mediterranean drainages. Similarly, fish from Garda L. (morph *carpio*; Italy) were not phylogenetically differentiated, being composed of mtDNA groups II and V, also observed in *marmoratus* and *fario* populations of the Adriatic basin.

*Population gene diversity*

The distance matrix of net interpopulation nucleotide divergence was used to construct a UPGMA tree (unweighted pair-group method using arithmetic averages) relating the 24 trout populations studied (Fig. 5). The populations clustered into four highly distinct groups (net nucleotide divergence among populations clusters ranging from 1.04 to 1.32%), largely reflecting the geographical and racial partitioning of mtDNA phylogenetic groupings. These clusters were:

1. *marmoratus* populations (u, v);
2. Mediterranean drainage populations (n, o);
3. Adriatic/Corsican drainage populations, including *carpio*, (p, q, s, t, w, x); and
4. Atlantic/Danube drainage populations (a–m, r).

Significant substructuring was also observed within each cluster. Thus, the two *marmoratus* populations (Rivers Pellice and Toce) were statistically differentiated ( $\chi^2_1 = 5.33, P < 0.025$ ) as were the two Mediterranean populations (Rivers Tes and Doubs;  $\chi^2_3 = 7.83, P < 0.05$ ). The two Corsican populations were also highly differentiated from the Adriatic populations ( $\chi^2_5 = 46, P < 0.001$ ), as were the Danube populations from the Atlantic populations ( $\chi^2_1 = 19.8, P < 0.001$ ). In contrast, no differentiation was observed between all populations from the Atlantic basin as all fish were fixed for the At1 genotype.

Contrary to the high interpopulation diversity observed (mean =  $1.05 \pm 0.57\%$ ), intrapopulation diversity was null or relatively low in most cases (mean nucleotide diversity estimates =  $0.25 \pm 0.38\%$ ). Thus, based on the  $N_{st}$  estimate of 0.76, only 24% of the overall genetic diversity observed was attributed to intrapopulation diversity as opposed to 76% for among populations.

**Discussion**

*Sequence variation in brown trout mitochondrial control region*

The rationale for studying sequence variation in segments of the mitochondrial DNA control region was motivated by evidence that those regions were hyper-variable in mammals, and exhibited higher genetic diversity than that detected by RFLP analysis or sequencing of

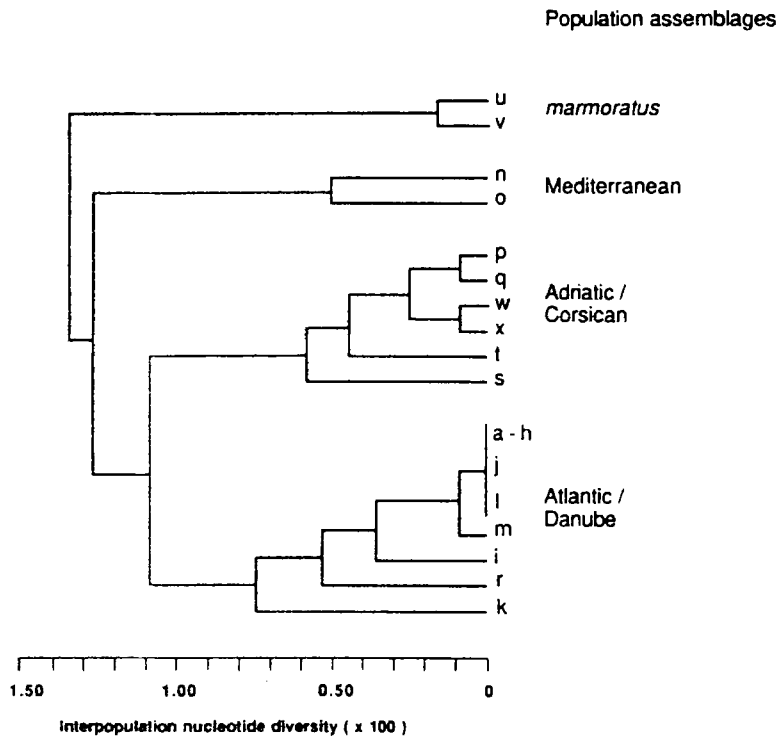

Fig. 5 Population tree (UPGMA) clustering 24 *S. trutta* populations according to the distance matrix resulting from the maximum likelihood estimation of the net average number of nucleotide substitutions per site among populations. Small letters denote the population names given in Table 1.

other regions of the molecule. For instance, in a study of the feral mouse, *Mus spretus*, Desmarais *et al.* (unpubl. data) found over three times as many polymorphisms by sequencing a 250-bp segment of the D-loop compared to RFLP analysis of 52 restriction sites. In the same study, nucleotide diversity within and between geographical regions was 10–15 times higher in sequence data. The mitochondrial control region of brown trout revealed more variation than that observed in sequence analysis of other fishes. In an interspecific study of cichlid fishes, only 15 sites out of 803 (mean number of nucleotide substitution per site ( $d$ ) < 0.005) showed base-substitutional differences in the cytochrome *b*, threonine, and proline tRNA genes, and in the most variable part of the control region (Meyer *et al.* 1990). In an analysis of cytochrome *b* gene variation in Atlantic cod (*Gadus morhua*) populations, Carr & Marshall (1991) found 1–5 mutational differences (mean  $d$  = 0.004) among transoceanic samples. Comparable variation was observed in the cytochrome *b* gene among tuna species (1–5 mutational changes) (Bartlett and Davidson, 1991) while a maximum of 2 mutational differences (mean  $d$  = 0.0035) were observed among transoceanic populations of the Atlantic salmon, *S. salar* (McVeigh *et al.* 1991).

Conversely to those observations, other evidence suggests that the control region of brown trout may not be as variable as reported for mammals. First, the levels of divergence we observed among mtDNA genotypes (range 0.16–1.92%) are well within the range of variation

frequently reported for intraspecific comparisons in fishes using RFLP analysis (e.g. Bermingham & Avise 1986; Bernatchez & Dodson 1991; Billington & Hebert 1991). Secondly, mtDNA RFLP studies among brown trout populations of northern Europe revealed several, although very slightly differentiated, mtDNA genotypes while the present study revealed monomorphism across the Atlantic basin. Thirdly, interspecific comparison with another sequence analysis (McVeigh *et al.* 1991), and an RFLP study (Gyllensten & Wilson 1987) were highly congruent. For instance, divergence values between *S. trutta* and *S. salar* estimated in the present study (5.44–6.44%) were only slightly higher than those observed in an analysis of the cytochrome *b* gene (range; 4.80–5.40%) and basically identical to RFLP analysis (6.18–6.52%). Similarly, comparable divergence estimates were observed in the control region sequence (L. Bernatchez, unpubl. data) and RFLP analysis between *S. salar* and the rainbow trout, *Oncorhynchus mykiss* (14.7% vs. 13.5%; range 13.14–14.19%).

Another major difference observed between variation in brown trout and mammal mitochondrial control regions, and in mtDNA coding regions, is in the nature of nucleotide substitutions. It has been generally observed that transitions greatly outnumber transversions (ratio 10:1) at the intraspecific level in the mammalian D-loop (Vigilant *et al.* 1989; Thomas *et al.* 1990) and in coding regions of mammals, birds, and fish (Beckenbach, Thomas & Sohrab 1990; Carr & Marshall 1991; Smith &



Patton 1991; Birt-Friesen *et al.* 1992). Although transitional events outnumbered transversions in this study, a much lower ratio was observed (17:6). This suggests that fundamental differences in patterns of mutation, functional and structural constraints may exist between the control regions of fish and mammals.

#### *Phylogeographic assemblages*

The goal of this study was not to present an overall and comprehensive phylogeographic survey of brown trout. While previous studies of genetic variation in *S. trutta* concentrated on specific geographic regions, we wanted to provide a first assessment of phylogenetic relationships between widely remote populations. However, many factors could limit the usefulness of such an approach. First, the relatively low number of populations sampled and the partial coverage of the wide natural geographic distribution of brown trout could lead to an underestimation of the existing diversity. Secondly, European trout populations have been extensively stocked and mixed over centuries, therefore decreasing the possibility of detecting phylogenetic signals among populations. Despite these potential limitations, the present study revealed that the brown trout represents one of the most genetically structured animal species studied to date. The  $N_{st}$  value of 0.76 observed between populations is higher than any other estimates reported for various groups of invertebrates and vertebrates (range 0.03–0.75; compiled in Lynch & Crease 1990; Table 4, p. 391).

The present study revealed the existence of five highly differentiated mtDNA phylogenetic groups. Based on sequence divergence estimates, those groups must have diverged from a common ancestor long ago, much before the last glaciation event that peaked some 18 000 years ago. Application of the 2% sequence divergence per million year molecular clock (Brown, George & Wilson 1979) would suggest that they diverged in the order of 450 000–700 000 years ago. However, this estimate must be considered as minimal, because if the rate of evolution in poikilotherm vertebrates differs from that of higher vertebrates, it is probably lower than 2% (Kocher *et al.* 1989). In contrast to the unambiguous phylogenetic groups observed, their branching pattern remained unresolved, largely due to the null or very small internode branch-lengths observed in the molecular trees. This suggests that isolation of all groups occurred at similar geological times.

The high level of geographic discontinuity between the five mtDNA groups is consistent with an ancient allopatric divergence within separate watersheds followed by limited natural intermixing over the last several hundred thousand years. Group I was almost entirely

confined to the Mediterranean drainages of France and is indicative of trout populations that may have survived in that region. Group II was mainly found in the Adriatic basin but also in Corsica and headwaters of a nearby Mediterranean river system. This suggests that these trout populations originated in Adriatic drainages and may subsequently have colonized Corsica, and also Mediterranean drainages by ancestral headwater connections. Group I was also observed in Corsica indicating that the island has been colonized by at least two very distinct lineages. Group III was only observed in Danube drainages and in nearby Adriatic basin headwaters of Bosnia Herzegovina, indicating the existence of a distinct group of trout populations in that region. Both phylogenetic analyses suggest that group III may represent the most divergent phylogenetic group among the populations surveyed. Group V was confined to the Adriatic basin indicating the existence of at least a second phylogenetic group in this region, highly divergent from group II. These latter two groups showed a discrete association with morphologically distinct populations. Finally, group IV was by far the most widespread and was the only one observed across all the Atlantic basin. It also dominated in the Danube basin and observed in some Mediterranean populations. The latter case is most likely the result of stock transfers as group IV was only observed in some populations known to have been contaminated by domestic strains which appear to originate exclusively from the Atlantic basin (Krieg & Guyomard 1985).

The presence of group IV in the Danube drainage is more problematic. Its dominance among Danube populations, even those without records of supplemental stocking, suggests an ancient origin of Group IV in this region. Yet one cannot entirely rule out unrecorded introductions from an Atlantic source. Altogether, these results suggest that group IV originated in either the Atlantic or Danube drainages and indicate that it may have been responsible for the recolonization of most of northern Europe following the last glacial retreat. However, these results do not deny the hypothesis that north-west Europe has also been colonized to a lesser extent by a second race postulated from allozyme data, today confined to some upper reaches (Hamilton *et al.* 1989), as the present study did not cover such tributaries.

#### *Levels of congruence with allozyme variation*

The geographic distribution of mtDNA diversity is congruent with patterns of genetic differentiation detected in earlier studies of allozyme variation. First, the mtDNA phylogenetic discontinuity between Atlantic and Mediterranean drainages parallels the patterns found by Krieg & Guyomard (1985) and Guyomard (1989) which

demonstrated a dichotomic differentiation between both basins in French populations. Both mitochondrial and allozyme analyses indicated that multiple colonization may have occurred during the evolution of Corsican trout (Guyomard, 1989).

Conversely, major discrepancies between mtDNA and protein variation analyses were observed in the extent of both intra- and inter-population levels of genetic variation. Most populations surveyed in this study revealed low levels of intrapopulation diversity. This is particularly true for the Atlantic basin populations in which no sequence variation was detected. In contrast, these populations exhibited high levels of protein variation, with an average level of heterozygosity of 0.047, ranging from 0.0 to 0.122 (Gyllensten, 1985; Ferguson, 1989). Similarly, sharp differences in allele frequencies, even on a small geographic scale, characterized many of those populations, whereas monomorphy was observed in mtDNA sequences. Lack of congruence between mitochondrial and nuclear gene patterns of variation is to be theoretically likely because of different modes of transmission and evolution, and it has been, in fact, frequently reported (e.g. Ward, Billington & Hebert 1989; Ferguson, Danzmann & Hutchings 1991).

#### *Lack of congruence between genotypic and phenotypic variation*

The wealth of phenotypic variation observed in brown trout has led to taxonomic recognition of numerous geographical and ecological forms that most often filled the literature with very confusing and inconsistent nomenclature. It has been common practice to recognize the basic ecological forms of *S. trutta*, i.e. anadromous, lacustrine, and fluviatile as *trutta*, *lacustris*, and *fario*, respectively. Depending on authorships, these names have been treated as species, subspecies or morphs. However, it has been suggested for a long time that such a classification does not represent a natural assemblage resulting from a monophyletic divergence (e.g. Nümann 1967; Behnke 1972). This has also been clearly demonstrated by protein variation analyses (e.g. Guyomard *et al.* 1984; Hinder *et al.* 1991). The present study corroborates those observations. Clearly, distinct ecological morphs of trout are expressed independently in many isolated drainages.

However, the systematics and phylogenetic status of geographical forms remained pretty much unresolved. Based on the extent of morphological differentiation, and again depending on authorships, various geographical variants have been recognized either as full species, subspecies or morphs, yet it is widely acknowledged that the utility of morphological criteria classically used in assessing phylogenetic relationships in salmonids, such as meristic counts or coloration, is hampered by their

phenotypic plasticity (Allendorf, Ryman & Utter 1987). The present study corroborates this view and casts doubts on the usefulness of different hierarchical taxonomic recognition based solely on morphological patterns.

For instance, the full range of mtDNA phylogenetic discontinuity described in this study was observed among fluviatile trout populations sampled in different drainages, but representing the single morph *fario* based on morphological similarities. In contrast, none of the most morphologically distinct populations treated here exceeded levels of divergence observed within *fario*. Based on its high morphological distinctiveness, the marble trout, *S. marmoratus*, has been hypothesized to represent the earliest branching in the *S. trutta* complex (e.g. Behnke 1968). The present results fully support the evolutionary distinctiveness of *marmoratus* by indicating its ancient monophyletic divergence. However, its branching does not appear to be earlier than that of any other phylogenetic groupings identified. Our results also indicated a much more recent divergence of the other morphologically differentiated populations, i.e. *letnica*, *carpio* and *macrostigma*. This emphasizes the importance of considering both genetic and morphological analyses to better understand the role of different evolutionary forces in shaping patterns of organismal evolution.

#### Acknowledgments

The authors are indebted to the numerous collaborators that kindly provided us with tissue samples: D. Beaudoux, O. Enderlein, G. Forneris, D. Gerdaux, R. Giannatelli, N. Hristovski, M. Luczynski, I. P. Muniz, B. Roché, C. Rhulé, J. Schoffmann, and J. Vostradrovsky. We also thank S. Johansen for his help in choosing primers. L.B. is also grateful to R. Mazart, P. Garcia, and L. Després for their technical assistance, and to M. Giroux for the realization of Fig. 4. The paper was improved by comments from B. Klönkle. This study was financed by a research grant to R.G. and F.B. from the Bureau des Ressources Génétiques, Ministère de la Recherche et de la Technologie (France). L.B. was supported by NSERC (Canada) and AUPELF (France-Canada) fellowships.

#### References

- Allendorf FW, Ryman N, Utter F (1987) Genetic and fishery management: past, present, and future. In: Ryman N, Utter F (eds) *Population Genetics and Fishery Management*, pp. 144–160. University of Washington Press, Seattle.
- Anconna UD, Merlo S. (1959) Speciation in Italian trouts with special reference to those of Lake Garda. *Proceedings of the International Congress of Zoology*, XV, 141–145.

- Avise JC, Arnold J, Ball RM et al.** (1987) Intraspecific phylogeography: the mitochondrial DNA bridge between population genetics and systematics. *Annual Reviews of Ecology and Systematics*, **18**, 489–522.
- Bartlett SE, Davidson WS** (1991) Identification of *Thunnus* species by the polymerase chain reaction and direct sequence analysis of their mitochondrial cytochrome *b* genes. *Canadian Journal of Fisheries and Aquatic Sciences*, **48**, 309–317.
- Beckenback AT, Thomas WK, Sohrabi H** (1990) Intraspecific sequence variation in the mitochondrial genome of rainbow trout (*Oncorhynchus mykiss*). *Genome*, **33**, 13–15.
- Behnke RJ** (1968) A new subgenus and species of trout, *Salmo (Platysalmo) platycephalus*, from Southcentral Turkey, with comments on the classification of the subfamily salmoninae. *Mitt. Hamburg Zool. Museum Institute*, **66**, 1–15.
- Behnke RJ** (1972) The systematics of salmonid fishes of recently glaciated lakes. *Journal of Fisheries Research Board of Canada*, **29**, 639–671.
- Behnke RJ** (1986) Brown trout. *Trout*, **27**, 42–47.
- Bermingham E, Avise JC** (1986) Molecular zoogeography of freshwater fishes in the Southern United States. *Genetics*, **113**, 939–966.
- Bernatchez L, Dodson JJ** (1991) Phylogeographic structure in mitochondrial DNA of the lake whitefish (*Coregonus clupeaformis*) and its relation to Pleistocene glaciations. *Evolution*, **45**, 1016–1035.
- Bernatchez L, Savard L, Dodson JJ, Pallotta D.** (1988) Mitochondrial DNA sequence heterogeneity among James–Hudson Bay anadromous coregonines. *Finnish Fisheries Research*, **9**, 17–26.
- Billington N, Hebert PDN** (1991) Mitochondrial DNA diversity in fishes and its implications for introductions. *Canadian Journal of Fisheries and Aquatic Sciences*, **48**, 80–94.
- Birt-Friesen VL, Montevecchi WA, Gaston AJ, Davidson WS** (1992) Genetic structure of thick-billed murre (*Uria lomvia*) populations examined using direct sequence analysis of amplified DNA. *Evolution*, **46**, 267–272.
- Blanc JM, Benarescu P, Gaudet J-L, Hureau J-C** (1971) *European Inland Water Fish, Multilingual Catalogue*. Fish News Books, London.
- Blanc JM, Poisson H, Vibert R** (1983) Variabilité génétique de la ponctuation noire sur la truitelle fario (*Salmo trutta* L.). *Annales de Génétique et Sélection Animale*, **14**, 225–236.
- Brown WM, George M Jr, Wilson AC** (1979) Rapid evolution of animal mitochondrial DNA. *Proceedings of the National Academy of Sciences, USA*, **76**, 1967–1971.
- Buroker NE, Brown JR, Gilbert TA et al.** (1990) Length heteroplasmy of sturgeon mitochondrial DNA: an illegitimate elongation model. *Genetics*, **124**, 157–163.
- Carr SM, Marshall HD** (1991) Detection of intraspecific DNA sequence variation in the mitochondrial cytochrome *b* gene of Atlantic cod (*Gadus morhua*) by the polymerase chain reaction. *Canadian Journal of Fisheries and Aquatic Sciences*, **48**, 48–52.
- Chevassus B, Blanc JM, Bergot P** (1979) Déterminisme génétique du nombre de caeca pyloriques chez la truite fario (*Salmo trutta* L.). *Annales de Génétique et Sélection Animale*, **11**, 79–92.
- Crozier WW, Ferguson A** (1986) Electrophoretic examination of the population structure of brown trout, *Salmo trutta* L., from the Lough Neagh catchment, Northern Ireland. *Journal of Fish Biology*, **28**, 459–477.
- Ferguson A** (1989) Genetic differences among brown trout, *Salmo trutta*, stocks and their importance for the conservation and management of the species. *Freshwater Biology*, **21**, 35–46.
- Ferguson A, Taggart JB** (1991) Genetic differentiation among the sympatric brown trout (*Salmo trutta*) populations of Lough Melvin, Ireland. *Biological Journal of the Linnean Society*, **43**, 221–237.
- Ferguson MM, Danzmann RG, Hutchings JA** (1991) Incongruent estimates of population differentiation among brook charr, *Salvelinus fontinalis*, from Cape Race, Newfoundland, Canada, based upon allozyme and mitochondrial DNA variation. *Journal of Fish Biology*, **39** (suppl. A), 79–85.
- Guyomard R** (1989) Diversité génétique de la truite commune. *Bulletin Français de la Pêche et de la Pisciculture*, **314**, 118–135.
- Guyomard R, Grevisse G, Oury FX, Davaine P** (1984) Evolution de la variabilité génétique inter et intrapopulations de populations issues de mêmes pools génétiques. *Canadian Journal of Fisheries and Aquatic Sciences*, **41**, 1024–1029.
- Guyomard R, Krieg F** (1983) Electrophoretic variations in six populations of brown trout (*Salmo trutta* L.). *Canadian Journal of Genetics and Cytology*, **24**, 403–413.
- Gyllensten U** (1985) The genetic structure of fish: differences in the intraspecific distribution of biochemical genetic variation between marine, anadromous, and freshwater species. *Journal of Fish Biology*, **26**, 691–699.
- Gyllensten U, Wilson AC** (1987) Mitochondrial DNA of Salmonids: inter- and intraspecific variability detected with restriction enzymes. In: Utter F, Ryman N (eds) *Population Genetics and Fishery Management*, pp. 301–317. University of Washington Press, Washington, D.C.
- Hamilton KE, Ferguson A, Taggart JB, Tomasson T, Walker A, Fahy E** (1989) Post-glacial colonization of brown trout, *Salmo trutta* L.: *Ldh-5* as a phylogeographic marker locus. *Journal of Fish Biology*, **35**, 651–664.

- Hindar K, Jonsson B, Ryman N, Ståhl G (1991) Genetic relationships among landlocked, resident, and anadromous brown trout, *Salmo trutta* L. *Heredity*, **66**, 83–91.
- Hynes RA, Duke EJ, Joyce P (1989) Mitochondrial DNA as a genetic marker for brown trout, *Salmo trutta* L., populations. *Journal of Fish Biology*, **35**, 687–701.
- Johansen S, Guddal PH, Johansen T (1990) Organization of the mitochondrial genome of Atlantic cod, *Gadus morhua*. *Nucleic Acids Research*, **18**, 411–419.
- Karakousis Y, Triantaphyllidis CD (1988) Genetic relationship among three Greek brown trout (*Salmo trutta* L.) populations. *Polskie Archiwum Hydrobiologii*, **35**, 279–285.
- Karakousis Y, Triantaphyllidis CD (1990) Genetic structure and differentiation among Greek brown trout (*Salmo trutta* L.) populations. *Heredity*, **64**, 297–304.
- Kimura M (1980) A simple model for estimating evolutionary rates of base substitutions through comparative studies of nucleotide sequences. *Journal of Molecular Evolution*, **16**, 11–120.
- Kluge AR, Farris JS (1969) Quantitative phyletics and the evolution of anurans. *Systematic Zoology*, **18**, 1–32.
- Kocher TD, Thomas WK, Meyer A *et al.* (1989) Dynamics of mitochondrial DNA evolution in animals: amplification and sequencing with conserved primers. *Proceedings of the National Academy of Science of the USA*, **86**, 6196–6200.
- Kreitman M, Landweber LF (1989) A strategy for producing single-stranded DNA in the polymerase chain reaction: a direct method for genomic sequencing. *Gene Analytical Techniques*, **6**, 84–88.
- Krieg F (1984) *Recherche d'une différenciation génétique entre populations de Salmo trutta*. Thèse de 3<sup>e</sup> cycle, Université de Paris-sud, Orsay.
- Krieg F, Guyomard R (1983) Mise en évidence électrophorétique d'une forte différenciation génétique entre populations de truite fario de Corse. *Comptes-rendus de l'Académie des Sciences de Paris*, **296**, 1089–1094.
- Krieg F, Guyomard R (1985) Population genetics of French brown trout (*Salmo trutta* L.): large geographical differentiation of wild populations and high similarity of domesticated stocks. *Génétique, Sélection et Evolution*, **17**, 225–242.
- Lynch M, Crease TJ (1990) The analysis of population survey data on DNA sequence variation. *Molecular Biology and Evolution*, **7**, 377–394.
- MacCrimmon HR, Marshall TL (1968) World distribution of brown trout, *Salmo trutta*. *Journal of Fisheries Research Board of Canada*, **25**, 2527–2548.
- McVeigh HP, Bartlett SE, Davidson, WS (1991) Polymerase chain reaction/direct sequence analysis of the cytochrome *b* gene in *Salmo salar*. *Aquaculture*, **95**, 225–233.
- McVeigh HP, Ferguson A (1988) The application of mitochondrial DNA analysis in the study of population biology of the brown trout *Salmo trutta* L. *Polskie Archiwum Hydrobiologii*, **35**, 287–294.
- Meyer A, Kocher TD, Basasibwaki P, Wilson AC (1990) Monophyletic origin of Lake Victoria cichlid fishes suggested by mitochondrial DNA sequences. *Nature*, **347**, 550–553.
- Nei M (1987) *Molecular Evolutionary Genetics*. Columbia University Press, New York.
- Nümann W (1967) Marierungsversuche an Bach und Regenbogenforellen in Bodensee als Beitrag zur systematischen Eingliederung von Forellen. *Schweizerische Zeitschrift für Hydrobiologie*, **62**, 283–296.
- Osinov AG (1984) Zoogeographical origins of brown trout, *Salmo trutta* (Salmonidae): data from biochemical genetic markers. *Journal of Ichthyology*, **24**, 10–23.
- Osinov AG (1990a) The level of genetic variation and differentiation of the brown trout (*Salmo trutta* L.) in Tadjikistan. *Moscow University Biological Sciences Bulletin*, **45**, 37–41.
- Osinov AG (1990b) Low level of genetic variability and differentiation in ecological forms of Sevan trout *Salmo ischchan* Kessler. [Translated from] *Genetika*, **25**, 1827–1835 (1989).
- Palva TK (1986) *Cytogenetic and mitochondrial DNA analyses of four salmonid species*. PhD thesis, University of Kuopio, Finland.
- Patton JL, Smith MF (1992) mtDNA phylogeny of Andean mice: a test of diversification across ecological gradients. *Evolution*, **46**, 174–183.
- Ryman N (1983) Patterns of distribution of biochemical genetic variation in salmonids: differences between species. *Aquaculture*, **33**, 247–262.
- Ryman N, Allendorf FW, Ståhl G (1979) Reproductive isolation with little genetic divergence in sympatric populations of brown trout (*Salmo trutta*). *Genetics*, **92**, 247–262.
- Saiki RK, Scharf S, Faloona F *et al.* (1985) Enzymatic amplification of  $\alpha$ -globin genomic sequences and restriction site analysis for diagnosis of sickle cell anemia. *Science*, **230**, 1350–1354.
- Skaala O, Jorstad KE (1987) Fine-spotted brown trout (*Salmo trutta*): its phenotypic description and biochemical genetic variation. *Canadian Journal of Fisheries and Aquatic Sciences*, **44**, 1775–1779.
- Skaala O, Jorstad KE (1988) Inheritance of the fine-spotted pigmentation pattern of brown trout (*Salmo trutta* L.). *Polskie Archiwum Hydrobiologii*, **35**, 295–304.
- Skaala O, Nædval G (1989) Genetic differentiation between freshwater resident and anadromous brown trout, *Salmo trutta*, within watercourses. *Journal of Fish Biology*, **34**, 597–605.
- Smith M, Patton JL (1991) Variation in mitochondrial

cytochrome *b* sequence in natural populations of South American akodontine rodents (Muridae: Sigmodontinae). *Molecular biology and Evolution*, **8**, 85–103.

**Taggart JB, Ferguson A, Mason FM** (1981) Genetic variation in Irish populations of brown trout (*Salmo trutta* L.): electrophoretic analysis of allozymes. *Comparative Biochemistry and Physiology*, **69B**, 393–412.

**Thomas WK, Pääbo S, Villablanca FX, Wilson AC** (1990) Spatial and temporal continuity of kangaroo rat populations shown by sequencing mitochondrial DNA from museum specimens. *Journal of Molecular Evolution*, **31**, 101–112.

**Vigilant L, Pennington R, Harpending H, Kocher TD, Wilson AC** (1989) Mitochondrial DNA sequences in single hairs from a southern African population. *Pro-*

*ceedings of the National Academy of Sciences of the USA*, **86**, 9350–9354.

**Ward RD, Billington N, Hebert PDN** (1989) Allozyme and mitochondrial DNA variation in populations of walleye, *Stizostedion vitreum*. *Canadian Journal of Fisheries and Aquatic Sciences*, **47**, 2074–2084.

---

This research was done when L. Bernatchez was a postdoctoral fellow at University of Montpellier II. The paper is a result of collaboration between the groups of F. Bonhomme and R. Guyomard to develop and apply molecular approaches to the study of genetic population structure.

---