



PROCEEDINGS

IPIIC 2018

JUNE 17 - 22 | University of Groningen

5th International Physical Internet Conference
BRINGING PHYSICAL INTERNET TO LIFE

Towards a smart hyperconnected era of efficient and sustainable logistics, supply chains and transportation

The overarching theme of the 5th International Physical Internet Conference was Bringing Physical Internet to life. The conference program contained 6 days including a doctoral colloquium and pre-program, with a total of 8 keynotes, 21 workshops, a Talent lab session, and a meet the (future) CEO session. In total we have welcomed 90 contributions and more than 300 participants from 19 different nations participating in a variety of IPIC2018 events from June 17-June 22 at the University of Groningen.

In these proceedings you can find the papers that were accepted by the scientific committee. All papers contribute towards the conference theme theme by proposing new concepts and methodologies for solving practical problems in the Physical Internet. A wide range of topics is dealt with, including city logistics, synchronomodality, warehousing, inventory, blockchain, business models, and experiences with stakeholders.

By building further on this research and by treading new research avenues, we trust that the community can further advance knowledge to realize the Physical Internet vision. We are looking forward to see the next steps taken. We thank all reviewers and the members of the scientific and program committee for their contributions.

Gerlach van der Heide
Editor of the IPIC 2018 proceedings
University of Groningen
The Netherlands

Iris Vis
Chair of the organization committee
University of Groningen
The Netherlands

Scientific Committee

Angelos Amditis: Institute of Communication and Computer Systems (ICCS), Greece
Eric Ballot: PSL – Mines ParisTech, France
Paul Buijs: University of Groningen, The Netherlands
Yan Cimon: Université Laval, Canada
Florian Ehrentraut: TU Graz, Austria
Rod Franklin: Kühne Logistics University, Germany
Árni Halldórsson: Chalmers University of Technology, Sweden
Wout Hofman: TNO, The Netherlands
Walid Klibi: Kedge Business School, France
René de Koster: Erasmus University, The Netherlands
Maria Jesus Saenz: University of Zaragoza, Spain
Suzanne Marcotte: UQAM, Canada
Benoit Montreuil: Georgia Tech, USA
Shenle Pan: PSL – Mines ParisTech, France
Matthias Prandtstetter: AIT, Austria
Kees Jan Roodbergen: University of Groningen, The Netherlands
Oliver Schauer, University of Applied Sciences Upper Austria, Austria
Georg Simhandl: University of Vienna, Austria
Lori Tavasszy: TU Delft, The Netherlands
Iris Vis: University of Groningen, The Netherlands

Program Committee

Bas van Bree: TKI Dinalog, The Netherlands
Paul Buijs: University of Groningen, The Netherlands
Birgit Hendriks: Binnenstadservice, The Netherlands
René de Koster: Erasmus University, The Netherlands
Fernando Liesa: ALICE, Belgium
Benoit Montreuil: Georgia Tech, USA
Michiel Nijdam: Ports of Rotterdam, The Netherlands
Kees Jan Roodbergen: University of Groningen, The Netherlands
Lori Tavasszy: TU Delft, The Netherlands
Iris Vis: University of Groningen, The Netherlands

Doctoral colloquium Committee

Patrick Fahim: TU Delft, The Netherlands
Louis Faugere: Georgia Tech, USA
Joren Gijsbrechts: University of Leuven, Belgium
Gerlach van der Heide: University of Groningen, The Netherlands
Nicol Saaltink: University of Groningen, The Netherlands

Organizing Committee

Iris Vis: University of Groningen, The Netherlands (Chair)
Saskia van Gennip: University of Groningen, The Netherlands
Gerlach van der Heide: University of Groningen, The Netherlands
Nicol Saaltink: University of Groningen, The Netherlands
Dennie Kleijweg: University of Groningen, The Netherlands
Inger Zeevalkink: University of Groningen, The Netherlands
Lisa van Casteren: University of Groningen, The Netherlands
Jon Hummel: University of Groningen, The Netherlands

Contents

From the Digital Internet to the Physical Internet: A conceptual framework with a simple network model	5
<i>Chuanwen Dong and Rod Franklin</i>	
A deep reinforcement learning approach for synchronized multi-modal replenishment	21
<i>Joren Gijsbrechts and Robert Boute</i>	
Applying blockchain technology for situational awareness in logistics - an example from rail	31
<i>Wout Hofman, Jacco Spek, and Christian van Ommeren</i>	
Cellular Warehousing for Omnichannel Retailing: Internet of Things and Physical Internet Perspectives	46
<i>Xin Wang, Xiang T.R. Kong, George Q. Huang, and Hao Luo</i>	
Inventory Control Models towards Physical Internet: Lateral Transshipment Policy Determination by Simulation	62
<i>Banu Y. Ekren, Anil Akpunar, and Gizem Sağol</i>	
Towards Hyperconnected Supply Chain Capability Planning: Conceptual Framework Proposal	72
<i>Raphaël Oger, Benoit Montreuil, Matthieu Luras, and Frédérick Benaben</i>	
LogiPipe: A vision to close the Physical Internets last-mile gap while improving city health and prosperity	83
<i>Balthasar Schönangerer and Daniel Tinello</i>	
Smart Locker Based Access Hub Network Capacity Deployment in Hyperconnected Parcel Logistics	92
<i>Louis Faugère, Satya S. Malladi, Benoit Montreuil, Chelsea C. White III</i>	
Moving towards practical implementation of self-organizing logistics - making small steps in realizing the PI vision by raising awareness	106
<i>Hans Quak, Elisah van Kempen, and Meike Hopman</i>	
Optimising the Capacity of Parcel Lockers	120
<i>Russell G. Thompson, Cheng Cheng, and Kun An</i>	

A new network concept for Logistic Centres in Hungary - regional segmentation in line with the PI vision	129
<i>Florian Ehrentraut, Christian Landschützer, Telek Péter, and Tamás Bánya</i>	
Physical Internet enabled bulky goods urban delivery system: a case study in customized furniture industry	142
<i>Hao Luo, Siyu Tian, Xiang T.R. Kong</i>	
Analogies across Hubs and Routers in the Physical and Digital Internet	157
<i>Jordi Arjona Aroca and Salvador Furió Pruñonosa</i>	
Establishing a Physical Internet Test Region - Learnings from ATROPINE	170
<i>Patrick Brandtner, Maria Kalt, Michael Plasch, and Oliver Schauer</i>	
Urban Large-Item Logistics with Hyperconnected Fulfillment and Transportation	179
<i>Nayeon Kim, Nitish Kholgade, and Benoit Montreuil</i>	
Simulation-based optimization approach for PI networks	192
<i>Christian Haider, Alexander Kinast, Stefanie Kritzing, Erik Pitzer, and Michael Affenzeller</i>	
Arriving on time using uncertainty aware deep learning	205
<i>Fieke Hillerström, Maarten Kruithof, and Serena Oggero</i>	
Inventory Control under Possible Delivery Perturbations in Physical Internet Supply Chain Network	219
<i>Maroua Nouiri, Abdelghani Bekrar, and Damien Trentesaux</i>	
A Mathematical Formulation and Tabu Search Approach for the Road-Rail Assignment Problem	232
<i>Tarik Chargui, Abdelghani Bekrar, Mohamed Reghioui, and Damien Trentesaux</i>	
Physical Internet: Stakeholder Mapping	244
<i>Walid Mourhrib, Sahar Validi, Samir Dani</i>	
Do you see what I see? A simulation analysis of order bundling within a transparent user network in geographic space	260
<i>Tomas Ambra, An Caris, and Cathy Macharis</i>	
Impact of Modular Containerization and Continuous Consolidation on Hyperconnected Parcel Logistics Hub Design and Performance	276
<i>Shannon Buckley and Benoit Montreuil</i>	
The Meaning and Importance of True Intermodal Route Planning in the Context of the Physical Internet	289
<i>Matthias Prandtstetter</i>	
Trust in a multi-tenant, logistics, data sharing infrastructure: Opportunities for blockchain technology	299

From the Digital Internet to the Physical Internet: A conceptual framework with a simple network model

Chuanwen Dong^{1,*} and Rod Franklin²

¹Chalmers University of Technology, Gothenburg, Sweden

²Kuehne Logistics University, Hamburg, Germany

* Corresponding author: chuanwen.dong@chalmers.se

Abstract: *Despite the increasing academic interest and financial support for the Physical Internet (PI), surprisingly little is known about its operationalization and implementation. In this paper, we suggest studying the PI on the basis of the Digital Internet (DI), which is already a well-established entity. We propose a conceptual framework for the PI network using the DI as a starting point, and find that the PI network not only needs to solve the reachability problem, i.e., how to route an item from A to B, but also must confront the optimality problem, i.e., how to dynamically optimize the logistics-related metrics such as cost and time for the trip. The latter is often negligible in the DI because digital signals are traveling at almost the speed of light with minor marginal energy cost. We then propose a simple network model by using graph theory to support the implementation of the PI. The model covers the characteristics of the PI raised in the current literature and offers potentials for further quantitative analysis. We also propose a simple algorithm to solve the model and discuss how it can be used to operationalize the PI in a case study.*

Keywords: *Physical Internet, Digital Internet, graph theory, model, operationalization*

1 Introduction

There are a growing number of concerns about current logistics and transportation systems. From an economic aspect, transportation costs are steadily rising, which erodes the benefits of all other supply chain cost-saving efforts (Boston Consulting Group, 2015). From a social aspect, the over-utilized road network brings substantial “stress” to our society regarding accidents, noise, air pollution, etc. (Maibach et al., 2007). From an environmental aspect, whereas all other industry sectors are steadily reducing greenhouse gas emissions, the transportation sector is, unfortunately, increasing these emissions (EUROSTAT, 2015).

Clearly, the business-as-usual logistics industry is not sustainable and disruptive innovations are urgently needed. The Physical Internet (PI), originally described by Montreuil (2011), is regarded as such a paradigm-breaking concept to tackle the “logistics sustainability grand challenge”. Ballot et al. (2014) and Mervis (2014), have further elaborated the concept of the PI. They use the Digital Internet (DI), which is already a well-established artifact and widely-accepted service technology, to illustrate its potential as a design metaphor for the PI. The classical analogy is, whereas the Digital Internet transfers digital data smoothly among users, the Physical Internet moves physical objects seamlessly through an open and interconnected logistics network.

Despite its highlighted advantages, the PI has received serious criticisms. Recent research by Sternberg and Norrman (2017), among others, has challenged the PI by questioning a lack of developed business models that can illustrate how to move from the concept to its adoption. Their thoughts coincide with, e.g., Cimon (2014) and Treiblmaier et al. (2016), that the implementation of the PI remains a challenge. So far, the research on the PI has primarily

focused on its conceptual development and the promised effect thereof. Surprisingly little is known about how the PI can be operationalized.

In this paper, we aim to begin filling in this research gap by suggesting a model-based conceptual framework for the PI based on the DI. There are two reasons for this initiative: 1) Since the DI is a metaphor for the PI, there must exist similarities between the two, from their namesake to models and implementations; 2) The DI is already a well-established artifact. This paper intends to analyze the proposed conceptual framework and outline a feasible model for analyzing the complex PI problems. The focus is on understanding the relationship of the key components in the PI, proposing viable models that support its implementation, and stimulating relevant discussions and needed research.

The rest of the paper is organized as follows. In Section 2, we review the mature structure of the Digital Internet. In Section 3, we discuss why the Physical Internet is more complicated than the Digital Internet. On the basis of this discussion, we propose a simple network model of the Physical Internet and suggest a heuristic solution in Section 4. In Section 5, we present a case study showing how our model can be used to solve a simple problem of the Physical Internet. Finally, we discuss future research avenues in Section 6.

2 The Digital Internet

Since we aim to consult the mature Digital Internet (DI) to guide the design and operationalization of the Physical Internet (PI), we are primarily interested in the following two questions concerning the DI: 1) How is the DI structured and 2) How is data transmitted in the DI. In this section, we first present a simple network within the DI (called a computer network in the computer science literature) and then discuss data transmission by briefly explaining the relevant Internet protocols.

2.1 The internet networks

The DI is a complex engineering system that connects billions of devices all over the world and, theoretically, allows every device to communicate with all others. To this extent, it is hard to describe the whole DI. We instead show some pieces of the DI in Figure 1 that are sufficient to present the basic structure of it.

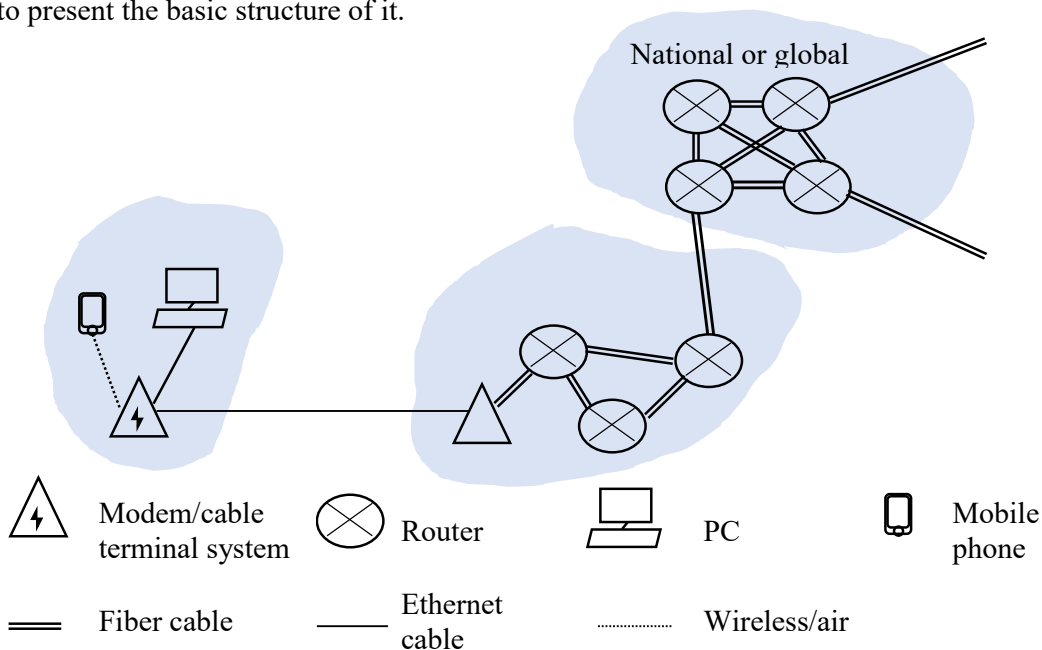

Figure 1 A simple schematic of part of the Digital Internet

Internet users could be governmental, commercial or private entities, all equipped with terminal devices such as computers or smart phones. The users insert flows into the DI in the form of digital data, which is sealed in data packets and transmitted via a network of communication links. Routers direct the data flows in the network, physical media such as copper and optical cables or air-based processes carry the data flows over the links, and modems / cable terminal systems allow data to be switched between different physical medias. The Internet services are operated by various Internet Service Providers (ISPs), which ensure smooth flows of all kinds of digital information.

Note, we use the term “router” as a general term to cover the functions of classic routers, switches and hubs. We recognize that there are significant differences in the functioning of these devices as independent devices. However, today’s modern routers have become general purpose devices incorporating the functionality of all three of these technologies, thus our use of the term “router” in its more modern manifestation.

2.2 The Internet protocols

The operationalization of the Internet, or more specifically, the smooth data transmission in the DI, would not be possible without standards. Internet protocols have been introduced to standardize and organize its operationalization. A protocol defines the format of the packets of digital information exchanged between peers in the DI, how hosts should be addressed, as well as the actions taken in the transmission of the packets across the DI.

The protocols have evolved over time to be organized in a layered architecture (Clark, 1988). A network layer is often a mixed implementation of hardware and software and focuses on a specific type of information transmission. When taken together, the collection of protocols at various layers becomes the “protocol stack”. The classic Internet protocol stack consists of five layers: the physical, link, network, transport, and application layers (Postel, 1981). We are aware that there exist other protocol structures that have been developed over the years. In particular, the International Organization for Standardization (ISO) (1989) proposed a well-known seven-layer model with two additional layers, the presentation layer and the session layer. We refer to Kurose and Ross (2016) for historical reasons for the prevalence of the ISO model, although “in fact, the inventors of the original OSI model probably did not have the Internet in mind when creating it” (Kurose and Ross, 2016, p. 53). Nevertheless, the functionality of both models is roughly the same, and it generally depends on Internet application developers to decide which implementation to use. Since we want to compare the

Table 1: How data flow is operationalized in a five-layer Internet protocol model

Layer	Operation
Application Layer	It communicates applications/services between separate Internet users. An example application is to send an email from one computer to another.
Transport Layer	It establishes the connection between Internet users to send the data and keeps track of the sending process.
Network Layer	It manages the routing of a data packet as it traverses the Internet from the sender to the receiver. The DI uses a connectionless model allowing the network itself to route a message from origination address to destination address using a “best effort” approach to the transmission of the packets.
Link Layer	It governs the data transmission within a single connection, e.g., the fiber connection.
Physical Layer	It ensures that the 0/1 digital data is transmitted in the physical media of the connection (e.g., the fiber connection mentioned before).

PI with the classical Digital Internet structure, we stick to the five-layer model to describe the flow of an email message in the Digital Internet. The function of each of these layers is briefly outlined in Table 1.

All the hardware and software components of the DI work under the contracts designed by these protocols. Whereas protocols in each layer focus on specific tasks, the operation of protocols across all five layers provide an operational solution to the reachability problem: how to transmit data from A to B. Note that the reachability problem, as defined here, is addressed in the Internet through what were originally called the DARPA Internet Protocols and are now known simply as TCP/IP (Clark, 1988). This function is, after all, what the Internet was created for. Considering the billions of users and countless amount of data transmitted over the Internet, solving the reachability problem is a tremendous accomplishment in and of itself.

3 From the Digital Internet to the Physical Internet

The Physical Internet is regarded as a conceptual metaphor of the Digital Internet. We first discuss the similarities and then the differences between the two concepts, with a special focus on the logistics-relevant metrics embedded in the PI.

3.1 Similarities between the DI and the PI

Inspired by the Digital Internet network in Figure 1, we present part of the Physical Internet network in Figure 2.

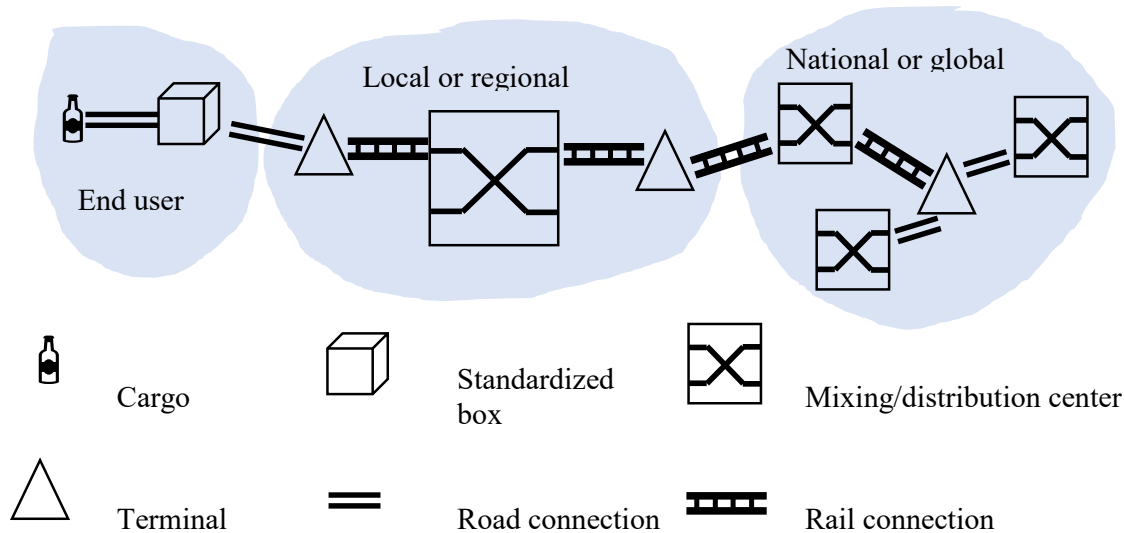

Figure 2: A simple schematic of part of the Physical Internet

The PI users could be both commercial and private shippers. They insert flows into the PI in the form of various physical objects such as groceries, consumer goods, etc., which are packed into standardized packages and then transported in a network of physical corridors. Mixing/distribution centers navigate the package flows in the network, transportation modes such as road or rail carry the package flows, and intermodal terminals allow cargo to switch

between different transportation modes. The PI services will be operated by various Logistics Service Providers (LSPs), which secure smooth deliveries of all kinds of physical objects.

By comparing Figure 2 with Figure 1, additional detailed similarities between the DI and the PI can be summarized (Table 2). Many of the distinct attributes of the PI, such as collaboration between different parties in the PI, can be traced to their counterparts in the DI. Note that this analysis only shows general comparisons between the DI and the PI. Its objective is to provide a better understanding of the two concepts going beyond their namesakes. More advanced and/or exceptional cases are always possible. For example, not all physical objects can be packed into standardized boxes. Some cargo will require special handling in packing, storing, etc. Typical of this example would be bulk cargo such as crude oil or grains, large-sized machinery parts, hazardous goods, and so on.

Table 2: The similarities between the Physical Internet and the Digital Internet

	Physical Internet	Digital Internet
User	Private and commercial shippers	Private and commercial Internet users
Flow	Physical objects	Digital data
Unit of the flow	Standardized packages, e.g., standard containers, the Modulushca box (European Commission, 2016)	Data packets
Routing of the flow	Ports, cross dock facilities, distribution centers, multi-modal transfer centers, etc.	Routers and switches
Carrier of the flow	Transportation modes, e.g., roads, rail, sea, air, inland waterway, pipeline	Physical medias, e.g., coaxial, fiber, air (wireless)
Protocols	Standardized sending/receiving processes	Five-layer Internet protocol model
Service providers	Logistics service providers	Internet service providers
Collaboration between operators	Transshipment and revenue sharing between different LSPs, groupage services, pallet networks	Roaming and revenue sharing between different ISPs
Collaboration between users	Shared transportation services, shared warehousing, etc.	Peer-to-peer networking, intranets, etc.
Collaboration between a user and an operator	3PL services	Dedicated access lines (e.g., T1 links)
Ownership of basic infrastructure	Partly government-owned (highways, bridges, etc.)	Primarily privately-owned (by the ISPs), but some government ownership, e.g., national telephone carriers, etc.

In its definition, the PI offers seamless interconnections of logistics services (Montreuil et al., 2013). In the light of this commitment, the PI is, despite all its other benefits, firstly an interconnected logistics system composed of a network of logistics networks. It should be able to deliver any physical item from any origin A to any destination B. As a result, the reachability problem should be the first problem to confront. This problem is conceptually similar to the reachability problem addressed by the DI. In the process of a physical object delivery, there are numerous protocol-like international agreements to standardize the flows, securing that cargo from different parts of the world can be delivered. For example, a letter should be first put into an envelope and then sent to the local postbox. Montreuil et al. (2012) compare the protocols and layers of the DI and the PI, and Hofman et al. (2017) offer additional insights into the differences between the DI layers and the PI layers.

The design of the DI and its protocols provide users with a “connection-free” service: They can simply use the DI without a need to understand how their data will be routed from its origination point to its destination. A similar “connection-free” service can be implemented in the PI: a PI user can trust the PI and its services to ship their goods to any destination without knowing (or caring) about the route that the goods take. An LSP controlling several key nodes in the network can route the shipment via any convenient route so long as it arrives as per agreement between the shipper and LSP. For example, a box is sent from Beijing to Brussels, the detailed route, Beijing – Tianjin – Rotterdam – Brussels, can remain anonymous and the exact route taken is left up to the operational considerations of the LSP.

3.2 Differences between the DI and the PI

Although the PI is regarded as an analog of the DI, they are two completely different things. The basic unit transported by the DI is digital data, electronic 0s and 1s. In other words, all flow in the DI can be exclusively represented by a sequence of standardized high or low voltage values, light pulses or carrier wave amplitudes and frequencies. The binary nature of signals used to encode information in digital packets establishes the basis of the DI and all relevant applications and protocols are designed based on this fundamental fact.

In the world of the PI, however, the basic flow consists of various physical objects that may be quite different from each other. There is no such thing as a standardized 0/1 unit that is the fundamental building block of these physical objects. Even if different physical objects can be packed into the same standardized boxes, and these boxes are treated equally in the PI by the LSPs, the boxes are valued differently from the eyes of the PI users because of their contents. A user probably does not care if they receive the same box in each shipment, but they do care if what is in the box is different from what they expect.

The Internet also employs the concept of packet retransmission, which allows packets that have been lost or discarded due to congestion at a router to be retransmitted after a period of time. Retransmission of physical goods is a costly undertaking and something that no user of the PI would appreciate seeing happen. Transporting physical objects instead of transmitting digital signals, therefore, requires additional effort in physical distribution. Important logistics metrics, therefore, in physical distribution need to be confronted. These metrics can be sorted into three major categories: cost, time, and schedule.

Cost:

Whereas sending an email incurs trivial variable cost linked to electricity consumption (infrastructure costs are generally included in the bandwidth and connection fees charged by ISPs and carriers), distributing a physical object incurs substantial variable costs linked to transportation modes, packing and unpacking, loading and unloading in distribution centers, etc. These costs extend beyond pure monetary costs to external costs including the costs of emissions, noise, pollution, congestion, etc.

Time:

Since digital signals are traveling almost at the speed of the light, their lags in the DI are, in most scenarios, negligible. The flowing speed and arrival time of physical objects in the PI, which is subject to transportation modes, availability of labor, handing time in the warehouses, etc., are critical to PI users. Transit times are not negligible and vary significantly by network routing decisions.

Schedule:

The transmission of digital information is almost instantaneous. Should problems arise in the transmission process, the speed at which rerouted signals or retransmitted packets travel make delays negligible (note that there are exceptions for certain information flows requiring continuous streaming or assured delivery). These facts mean that for most users of the DI the scheduling of information deliveries is not generally a concern. However, the schedule of flow in the PI is a dynamic and potentially problematic process subject to the real-time status of the PI. For example, if congestion arises or a vehicle breaks down, new routings may need to be implemented that lead to delayed deliveries. Such delays are of concern to shippers, customers and service providers as they may generate penalties, lost business and other additional costs.

The existence of these logistics metrics makes the complexity of the PI significantly greater than that of the DI. In addition, these three metrics are almost always correlated and need to be jointly considered. The PI not only needs to solve the reachability problem, i.e., routing from A to B, but also must confront the optimality problem, i.e., optimizing the logistics metrics for the physical distribution activities.

The three areas outlined above do not stand alone. Often, they are inter-connected and appear together. LSPs might want to quote their service to the PI user by combining cost with time using their evaluation of the transit route reliability and the user's specified quality of service requirements. Because users, downstream service providers and customers are interested in the scheduled movement of the goods real-time updates of the state of the PI are required. For example, after the user has contracted for a specific time and service level using the PI, an accident occurs and blocks part of the original planned route. In this case, the PI should be able to provide immediate updates and reoptimize the entire route. Given the originally negotiated terms, PI users might want to accept proposed changes in cost and/or service level based on the state changes of the PI, stick to their old plans and accept delays, or seek to penalize their service providers for failing to live up to their negotiated commitments.

The existence of these logistics metrics makes the complexity of the PI significantly greater than that of the DI. The PI not only needs to solve the reachability problem, i.e., routing from A to B, but also must confront the optimality problem, i.e., optimizing the logistics metrics in the physical distribution activities.

4 A simple model of the Physical Internet

By comparing the PI with the DI, we have learnt that the PI is a complex network consisting of a wide range of different entities, such as distribution centers, transportation modes, etc. The network needs to solve not only the reachability problem, but also the optimality problem. On the basis of this knowledge, we propose a simple graph structure to model and analyze the PI, covering both the reachability and the optimality problems of a network. For simplicity reasons, the graph is used to model the shipment process from the sender (left node) to the receiver (right node) with sets of vertices and edges.

4.1 Model formulation

Consider a directed graph $G = (V, E)$ consisting of a non-empty finite set V of vertices, and a non-empty finite set E of edges (Figure 3). The graph G has a distinguished source vertex $s \in V$ (left) and a sink vertex $r \in V$ (right), representing the sender and the receiver of the shipment. Other elements in set V , denoted as (v_1, v_2, \dots, v_M) , represent the infrastructures in the PI, such as packing stations (the black vertices), routing centers, terminals, etc. The elements in set E , denoted as (e_1, e_2, \dots, e_N) , are ordered pairs of distinct vertices, specifying the transportation corridors between two infrastructures in the Physical Internet.

Each edge with index $i \in N$ is associated with a weight $w_i^e(c_i^e, l_i^e, t)$. The weight is a three-element vector, expressing in period t , the transportation service covering this corridor e_i which incurs a monetary cost c_i^e and a lead time l_i^e . Each vertex with index $j \in M$ is also associated with a weight $w_j^v(c_j^v, l_j^v, t)$, which denotes that the operation in this infrastructure v_j in period t costs c_j^v and incurs lead time l_j^v . Note that weights will most likely be dynamic in a real-world situation changing based on any number of factors such as load, personnel and asset availability, macroeconomics, etc. For the simple model presented here we assume that the weights are essentially static to facilitate the exposition of the PI's reachability and optimality problems might be addressed.

The objective of the Physical Internet is to find a path from s to r , subject to some optimality conditions in cost and/or service levels.

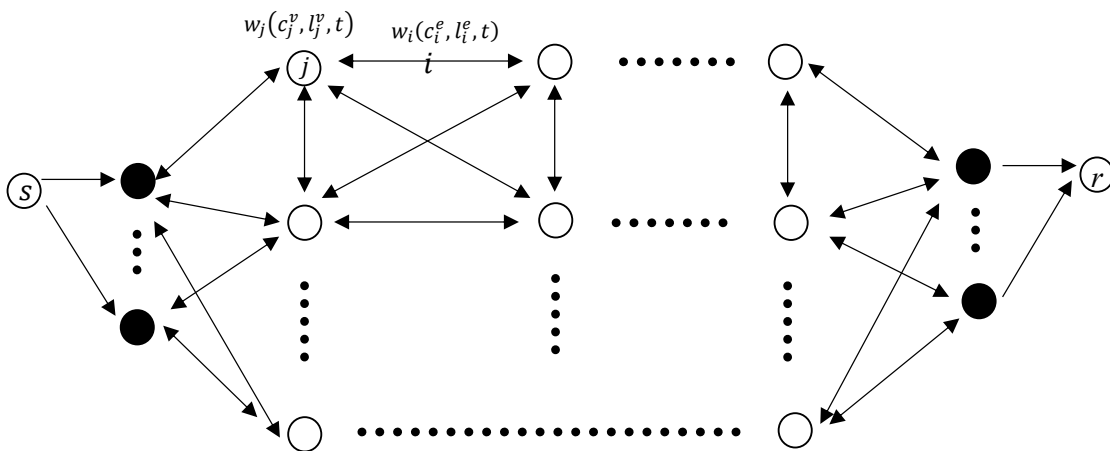

Figure 3: A simple network model for the Physical Internet

4.2 Model analysis and solution

If the graph G is deterministic with unchanged topology, and only the (monetary) cost is considered, the mathematical structure of the PI problem will be similar to that of the classical Travelling Salesman Problem (TSP): How to find a feasible route from the origin to the destination in a transportation network with the lowest total cost. Over the years significant research on the TSP has been conducted and its extensions can support PI research with practical considerations. For example, so-called dynamic, or time-dependent TSPs deal with changing costs. They can support the implementation of PI approaches that address situations where costs change dynamically due to, e.g., capacity availability or collaboration

opportunities. We refer to Applegate et al. (2006) as a reference of various TSP problems with extensions.

If only the time spent for the entire trip is considered, and a delay is caused due to large freight flows and limited capacity in (part of) the PI, knowledge from the classical Traffic Assignment Problem (TAP) can be borrowed for the analysis. The TAP deals with problems where traffic flows are delayed in a capacitated network. We refer to, among others, the Cell Transmission Model (Daganzo, 1994), the Link Transmission Model (Yperman et al., 2006), and the Network Transmission Model (Knoop and Hoogendoorn, 2016).

What makes modeling the PI different from either the TSP or TAP problems is: 1) the PI needs to dynamically consider both cost and time at the same time, and 2) the PI encompasses a vast network potentially incorporating all shippers and logistics service providers in the world, of which the problem size is considerably larger than any of the TSP or TAP problems studied in the literature so far.

Classical TSP or TAP problems are proven to be NP-hard. Considering the aforementioned features of the PI, standard routing and optimization approaches will not be suitable for its operation because even the most sophisticated algorithms developed to address TSP and TAP problems would be overwhelmed by the size and complexity of the PI problem itself.

As a result, we propose an iterative two-stage solution heuristic. In the first stage, the reachability problem is solved: given the current graph, find all walks from the current vertex v_j to the receiving vertex r . A walk between two vertices denotes a sequence of directed edges from the initial vertex to the final vertex. We denote K_t the set of walks in period t , and $k \in K_t$ the index of the set. In the second stage, the optimality problem is solved based on set K_t and the relevant weight variables w in period t . For example, if the total cost is minimized:

$$\min_{k \in K_t} \sum_{i \text{ in walk } k} c_i^e + \sum_{j \text{ in walk } k} c_j^v; \quad (1)$$

and the minimization of the total lead time means

$$\min_{k \in K_t} \sum_i l_i^e + \sum_j l_j^v. \quad (2)$$

In addition to the objectives shown in (1) and (2), the optimality problem of the PI could also focus on compromise solutions between cost and time. This is the flexibility the PI should offer to its users. For example, a shipper wants to minimize its total costs subject to a pre-defined minimal lead time constraint. In this case, the objective function (1) could be subject to an additional constraint, ensuring that the total lead time should not exceed a threshold value. Additional constraints on, e.g., capacity of an edge, could also be added to the model.

Whenever the part of the PI involved in the pre-decided solution is changed, the topology of the graph will be accordingly updated and the above two-stage optimization problem recalculated, until the physical object finally reaches the receiver. The flow chart of the algorithm is shown in Figure 4.

The key to our algorithm is to split a complex problem (the PI model) into two sub-problems (the reachability and optimality problems). Managerially speaking, these are two different problems embedded in the PI and can be decoupled, and our heuristic naturally mimics the practical operation of the PI. Technically speaking, our approach facilitates the solution of a more complex problem via a sequential and iterative process of solving two simpler sub-problems, which reduces the entire computing effort.

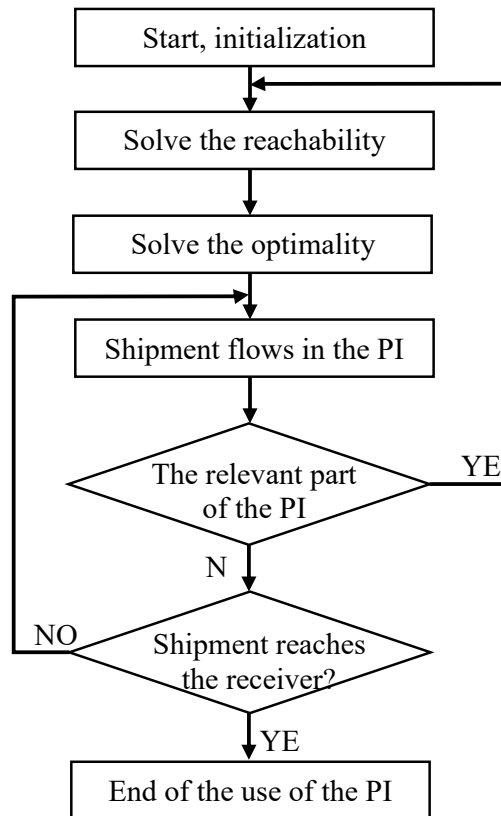

Figure 4: The flow chart of the Physical Internet algorithm

4.3 Reflection of the PI characteristics in the model

Montreuil (2011) has highlighted 13 characteristics of the PI that achieve the global logistics sustainability vision. Our current model, together with its potential extensions, covers these characteristics as illustrated in Table 3. Using graph theory, a rich literature exists to support innovations in the conceptualization and operationalization of the PI.

4.4 Model extension

The current model illustrates the optimality problem of the PI in the aspects of cost and lead time. Statistically speaking, only the first moments of both values are evaluated. It could be interesting to measure the second moments of these objectives. The second moment of the lead time is its punctuality, and the cost could also be a changing number depending on, e.g., the shipment volume. It is even necessary to consider both the first and the second moments together. For example, sometimes a shipper might want to choose a more punctual transportation service, even if that requires a longer, but more reliable lead time

The PI could also consider other objectives besides cost and lead time. A typical example would be the greenhouse gas emissions of the transportation service. Each vertex and edge of the graph in Figure 3 could then be associated with an additional weight, representing the emissions discharged from the relevant infrastructure or transportation. An objective function minimizing total emissions, similar to Equations (1) and (2), would then be added to the model.

Table 3: The main characteristics of the PI mentioned in Montreuil (2011) can be incorporated in our model

Characteristics of the PI (Montreuil, 2011)	Covering of the characteristics in our PI model
Encapsulate merchandises in world-standard smart green modular containers	A packing station is modeled as a vertex in the graph.
Aiming toward universal interconnectivity	Interconnectivity is modeled as edges connecting vertices in the graph.
Evolve from material to pi-container handling and storage system	Any material into the PI (vertex s) must first travel to a packing station (solid vertex) and then flow in the PI.
Exploit smart networked containers embedding smart objects	The current weights of the edges/vertices of the graph can be extended, representing additional information linked to the smart objects/containers
Evolve from point-to-point hub-and-spoke transport to distributed multi-segment intermodal transport	Our graph is not hub-and-spoke. Instead, it represents a general distributed network with dynamic changes in topology.
Embrace a unified multi-tier conceptual framework	The vertices and edges between s and r are general settings and can represent any more specific multi-tier networks. Nodes are purposely left simple, but could be modeled in a hierarchical manner in which PI protocols operate similar to the sub-net operations that occur in the DI.
Activate and exploit an Open Global Supply Web	The graph can represent any kind of global supply web.
Design products fitting containers with minimal space waste	This is more from the production side and is not included in our PI model
Minimize physical moves and storages by digitally transmitting knowledge and materializing objects as locally as possible	An additional weight of the edges and vertices representing the physical moves can be incorporated into the current graph to tackle this point. The solution method will be similar to the current lead time minimization process.
Deploy open performance monitoring and capability certifications	The real-time update of the topology of the graph is based on real-time performance monitoring of the PI.
Prioritize webbed reliability and resilience of networks	Reliability and resilience can be modeled as how often /how much the topology of the graph is changed.
Stimulate business model innovation	There is a rich body of graph theory literature to support innovations in the current model.
Enable open infrastructural innovation	There is a rich body of graph theory literature to support innovations in the current infrastructure.

So far, the objectives are isolated and solved separately. A PI user might want to find a compromise solution between cost and lead time, or cost and emissions. Such conditions will then be inserted into the model in the initialization stage of the flow chart in Figure 4, and multi-objective optimization algorithms would be needed.

Additional practical constraints could be incorporated into the model. For example, a warehouse or a transportation mode might have capacity constraints, the standardized packages have different sizes instead of one, and the shipper might want reverse logistics services in the PI. These constraints could also be dynamic. For example, if the present optimality problem does not give feasible solutions, the shipper (or any other responsible person) is notified, who can decide whether to quit the PI, or accept the new cost/services conditions.

5 The implementation of the PI model: a case study

In this section we present a simple case study, demonstrating how an operationalization of the physical internet can be modeled and solved using the theory proposed in the previous sections. The main objective of the case study is to describe the feasible implementation of our model, rather than prescribing detailed solutions of real world physical internet problems. As a result, an uncomplicated network with simple numbers are used.

5.1 The problem

A PI user wants to send a bottle of wine to a friend. Assume that the part of the PI that could be used for this shipment is shown in Figure 5.

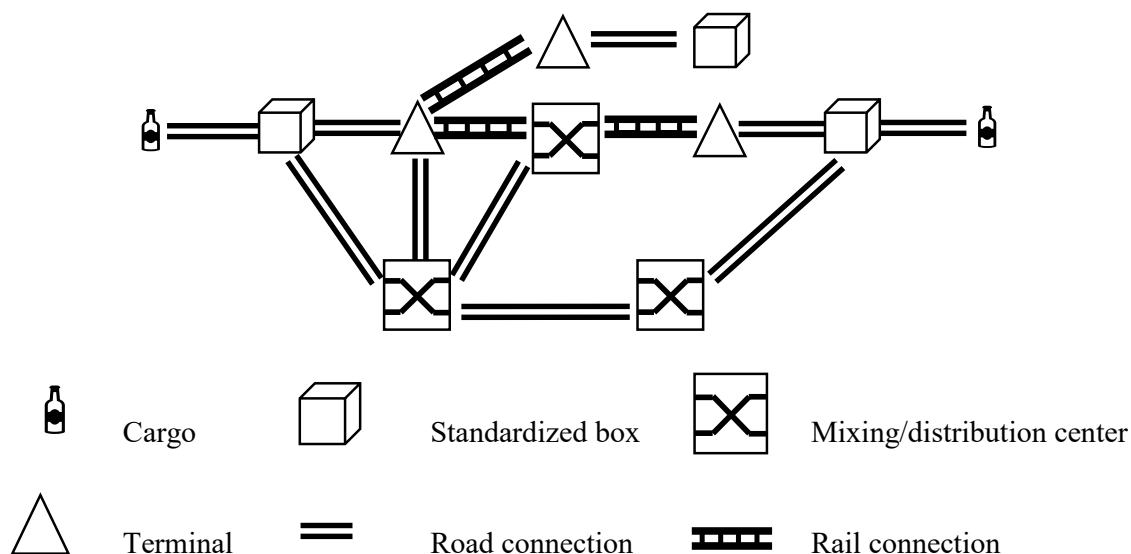

Figure 5: Part of the Physical Internet involved in a wine delivery

5.2 Model formulation

The problem can be modeled in a graph shown in Figure 6. When the shipment enters the PI, it stays at the initiate vertex s , and needs to be delivered to the final vertex r . Nine other infrastructures of the PI, denoted as vertices v_1, \dots, v_9 , as well as the transportation services connecting these infrastructures, denoted as the edges, are available to optimize the shipment process.

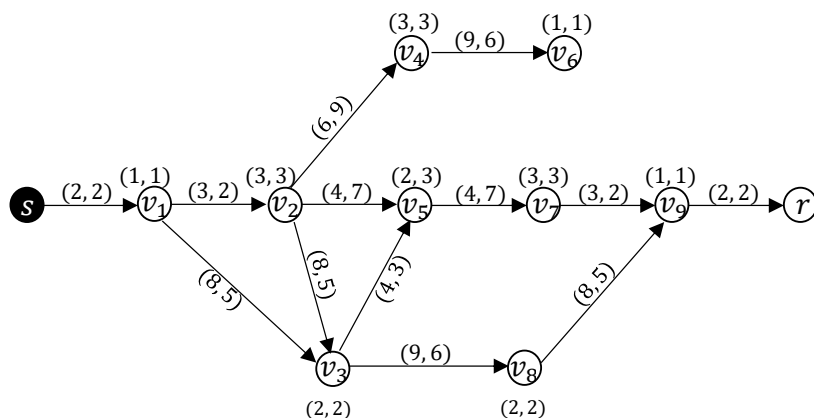

Figure 6: The shipment problem illustrated in Figure 5 can be modeled in a graph

Each vertex and each edge is associated with a weight vector shown in parentheses. Since this is a snapshot of the PI model in a specific time, the time indexes of the weights are dropped. A weight vector represents the cost and time required to use this part of the PI. Both values are normalized. For example, the use of vertex v_1 requires one unit of money and one unit of time, and the shipment from v_2 to v_4 incurs a cost of six units and a lead time of nine units.

Currently the shipment stays in vertex s . When it starts to flow in the PI, the topology of the graph, as well as the weight vectors in Figure 6 might be changed. The objective of the model is to deliver the shipment from s to r , subject to pre-defined service conditions, e.g., with lowest cost or least lead time.

5.3 Model solution process

According to the flow chart in Figure 4, we first solve the reachability problem and then the optimality problem. The reachability problem is solved by finding all feasible walks from s to r , which results in the five walks listed in Table 4. There are a couple of well-established algorithms, e.g., Floyd-Warshall's Algorithm, to solve the reachability problem of a directed graph. Interested readers could refer to, among others, Cormen et al. (2009). Note, vertices v_4 and v_6 are not mentioned because they do not connect to the final vertex.

Table 4: Feasible walks of the graph and the corresponding cost and lead time

Index	Walk from vertex s to vertex r	Total cost	Total lead time
1	$s \rightarrow v_1 \rightarrow v_2 \rightarrow v_3 \rightarrow v_5 \rightarrow v_7 \rightarrow v_9 \rightarrow r$	38	36
2	$s \rightarrow v_1 \rightarrow v_2 \rightarrow v_3 \rightarrow v_8 \rightarrow v_9 \rightarrow r$	41	31
3	$s \rightarrow v_1 \rightarrow v_2 \rightarrow v_5 \rightarrow v_7 \rightarrow v_9 \rightarrow r$	23*	33
4	$s \rightarrow v_1 \rightarrow v_3 \rightarrow v_5 \rightarrow v_7 \rightarrow v_9 \rightarrow r$	32	31
5	$s \rightarrow v_1 \rightarrow v_3 \rightarrow v_8 \rightarrow v_9 \rightarrow r$	35	26*

In the next step, the optimality problem is confronted according to the pre-defined service of the PI. For example, if the service term is to minimize the total cost, then the five walks with the lowest total cost (walk three) is chosen; if the service term is the fastest delivery, then walk five with the shortest lead time is chosen. Note, walk three is the solution to use a significant

part of relatively cheap rail transport and walk five is a road-express with higher cost but shorter time (Figure 5).

The PI is able to dynamically update its service according to real-time conditions. For example, when the shipment arrives at v_2 , it is possible that the connection to v_5 is broken and the graph is therefore updated to Figure 8. We assume that all the weight vectors remain the same.

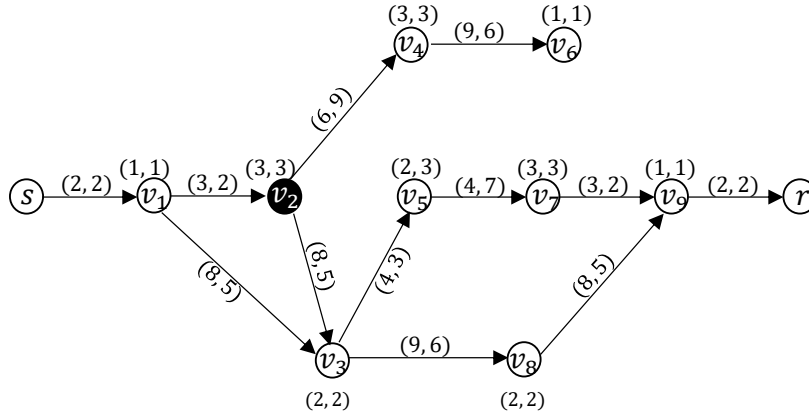

Figure 7 : Update of the graph according to real-time traffic conditions

At this moment, the reachability and optimality problems need to be solved again. Table 5 summarizes the results. At this moment, there are only two feasible walks, both offer different trade-off in cost and lead time.

Table 5: Updated walks of the graph and the corresponding cost and lead time

Index	Walk from v_2 to r	Total cost	Total lead time
1	$v_2 \rightarrow v_3 \rightarrow v_5 \rightarrow v_7 \rightarrow v_9 \rightarrow r$	38*	36
2	$v_2 \rightarrow v_3 \rightarrow v_8 \rightarrow v_9 \rightarrow r$	41	31*

This process continues until the shipment arrives at vertex r .

6 Summary

The main contribution of this paper is the proposal of a feasible Physical Internet (PI) model-based conceptual framework that supports its implementation. This model bridges the current gap between the high-level PI concept and its expected benefits. We first compare the Physical Internet with its conceptual metaphor, the Digital Internet, and identify the reachability and optimality problems in a network. On the basis of this knowledge, we use a graph to model the PI, and suggest an algorithm to solve it. Our model and solution are further illustrated in a case study, demonstrating the operationalization of a simple PI problem.

Since the PI is an extensive concept that potentially covers all aspects of future transportation problems, our model obviously needs extensions. For example, for the cargo that cannot be packed into standardized boxes, the graph will be changed. When a natural disaster happens, infrastructures are damaged and governments might interfere, and special modes might be needed for such special cases. Luckily, the literature in graph theory is extremely rich and various graph theoretical approaches and extensions could support these special PI problems.

More characteristics of the PI could be incorporated into the model. For example, the cost and time could depend on more parameters such as the shipment size, node throughput times, arc constraints such as capacities, speed limits, carrier limitations, etc. Multiple cargos could be sent into the PI and corresponding collaboration and joint replenishment opportunities could be studied. A possible use of the PI would be to distribute and store inventory that does not yet have a final destination. In this case cargo would be pushed into the PI while it is still not clear who would be the final receiver and the cargo would need to be stored somewhere in the PI. In this case the reachability problem and the sequential optimality problem would need to be updated as to who the ultimate receiver was.

Many other scenarios can be envisioned that extend the simple model outlined in this paper. As the PI is a new and emerging research area it has not been the intention of this paper to exhaustively study the many possible issues that must be addressed to operationalize the PI concept. However, it is hoped that this paper helps in establishing the ongoing development of the PI concept so that the benefits identified thus far from this approach to transport and logistics can ultimately be realized.

References

- Applegate, D.L., Bixby, R.E., Chvatal, V., Cook, W.J., 2006. *The Traveling Salesman Problem: A Computational Study*. Princeton University Press.
- Ballot, E., Montreuil, B., Meller, R.D., 2014. *The Physical Internet - The Network of Logistics Networks*.
- Boston Consulting Group, 2015. *A Hard Road: Why CPG Companies Need a Strategic Approach to Transportation*.
- Cimon, Y., 2014. *Implementing the Physical Internet Real-World Interface: Beyond Business Models, the Devil is in the Details*, in: *First International Physical Internet Conference*. Quebec City, Canada.
- Clark, D., 1988. The design philosophy of the DARPA Internet protocols. *ACM SIGCOMM Comput. Commun. Rev.* 18, 106–114.
- Cormen, T.H., Leiserson, C.E., Rivest, R.L., Stein, C., 2009. *Introduction to Algorithms*, 3rd ed. The MIT Press.
- Daganzo, C.F., 1994. The cell transmission model: A dynamic representation of highway traffic consistent with the hydrodynamic theory. *Transp. Res. Part B Methodol.* 28, 269–287.
- European Commission, 2016. *Modular Logistics Units in Shared Co-modal Networks [WWW Document]*. URL https://cordis.europa.eu/project/rcn/105754_en.html
- EUROSTAT, 2015. *Greenhouse gas emission statistics*. URL http://ec.europa.eu/eurostat/statistics-explained/index.php/Greenhouse_gas_emission_statistics. Accessed on 14 December, 2016.
- Hofman, W., Spek, J., Brewster, C., 2017. *Applying blockchain technology for hyperconnected logistics*, in: *Fourth International Physical Internet Conference*.
- International Organization for Standardization, 1989. *Information processing systems - Open Systems Interconnection - Basic Reference Model*.

- Knoop, V.L., Hoogendoorn, S.P., 2016. Network Transmission Model: a Dynamic Traffic Model at Network Level, in: Proceedings of the 95th Transportation Research Board Annual Meeting.
- Kurose, J., Ross, K., 2016. Computer Networking - A Top-Down Approach, 7th ed. Pearson.
- Maibach, H., Schreyer, C., Sutter, D., van Essen, H.P., Boon, B.H., Smokers, R., Schrotten, A., Doll, C., Pawlowska, B., Bak, M., 2007. Handbook on estimation of external costs in the transport sector, report produced within the project Internalisation measures for all external costs of transport (IMPACT).
- Mervis, J., 2014. The information highway gets physical: The Physical Internet would move goods the way its namesake moves data". *Science* (80-.). 344, 1104–1107.
<https://doi.org/10.1126/science.344.6188.1100>
- Montreuil, B., 2011. Toward a Physical Internet: meeting the global logistics sustainability grand challenge. *Logist. Res.* 3, 71–87.
- Montreuil, B., Ballot, E., Fontane, F., 2012. An open logistics interconnection model for the Physical Internet. Proceedings of the 14th IFAC Symposium on Information Control Problems in Manufacturing, Bucharest, Romania.
- Montreuil, B., Meller, R.D., Ballot, E., 2013. Physical Internet Foundations, in: Borangiu, T., Thomas, A., Trentesaux, D. (Eds.), *Service Orientation in Holonic and Multi-Agent Manufacturing and Robotics*. Springer, Berlin, pp. 151–166.
- Postel, J., 1981. Internet protocol DARPA internet program protocol specification.
- Sternberg, H., Norrman, A., 2017. The Physical Internet – review, analysis and future research agenda. *Int. J. Phys. Distrib. Logist. Manag.* 47, 736–762.
- Treiblmaier, H., Mirkovski, K., Lowry, P.B., 2016. Conceptualizing the Physical Internet: Literature Review, Implications and Directions for Future Research. Available SSRN <https://ssrn.com/abstract=2861409>.
- Yperman, I.S., Logghe, C.M., Tampere, J., Immers, B., 2006. Multicommodity link transmission model for dynamic network loading, in: Proceedings of the 85th Annual Meeting of the Transportation Research Board 85th Annual Meeting.

A deep reinforcement learning approach for synchronized multi-modal replenishment

Joren Gijsbrechts¹ and Robert Boute^{1,2}

¹Research Center for Operations Management, Faculty of Business and Economics,
KU Leuven, B-3000 Leuven, Naamsestraat 69, Belgium.

²Technology & Operations Management Area, Vlerick Business School
B-3000 Leuven, Belgium

Corresponding author: joren.gijsbrechts@kuleuven.be

Abstract: *We optimize the multi-modal replenishment process of a distribution center: a setting where multiple transport options are available, each with a different cost and transport lead time. We develop a smart algorithm, leveraging machine learning techniques, to solve this analytically intractable problem. Distinguishing features of our model are that it captures the full delivery schedule of pipeline inventories while being more versatile to include practical limitations such as transport service schedules.*

Keywords: *multi-modal replenishment, dual sourcing, machine learning, deep reinforcement learning*

1 Introduction

The supply chain of an enterprise is a complex environment with many specific elements, requiring tailored models to optimize its performance. In this article we focus on the replenishment process using multiple transport modes in parallel, each with its own transport lead time and cost. Our problem setting is equivalent to the dual sourcing problem, in which inventory can be replenished either from a nearby but expensive source or from a remotely located cheaper source. As shown by Whittemore and Saunders (1977), obtaining an exact solution for the dual sourcing problem (assuming realistic lead times) requires dynamic programming because of the complexity stemming from the pipeline inventory vector. Unfortunately, due to the curse of dimensionality inherent to dynamic programming, the dual sourcing problem becomes intractable for long lead times. Hence, existing policies take specific lead time assumptions or only moderately take into account inventories in transit by for instance using the inventory position (the sum of in-transit and on-hand inventory). Optimal solutions for the dual sourcing problem are consequently only available for very specific circumstances, leaving space for researchers to improve existing heuristic policies in terms of performance and practical relevance.

We aim to close this gap by providing a model that incorporates the delivery schedule of the pipeline inventory into the decision making process, using recent breakthrough techniques from the field of machine learning. Recent models in this blooming field show superhuman performance, beating for instance the Alpha Go world champion (Silver et al., 2017, 2016), or successfully playing 49 Atari games with one single algorithm (Mnih et al., 2015). Re-applying these techniques in a supply chain context, we develop a synchronized multi-modal replenishment policy, improving the performance of existing policies and allowing replenishment problems to be solved in a broader setting compared to the current dual sourcing policies. Moreover, our model is versatile to include delivery schedules (i.e. the timetable of planned departures) of the different transport modes, thus allowing different delivery

frequencies between the fast and slow mode, a situation which is often neglected in the academic literature, despite it being closer to reality in most cases.

2 Literature

2.1 Dual Sourcing

Replenishing by multiple transport modes in parallel is mathematically equivalent to sourcing from multiple sources with a different lead time, known as the dual sourcing problem in literature. We refer the reader to Minner (2003) and Yao and Minner (2017) for overviews until respectively 2003 and 2017.

Three often-used periodic dual sourcing policies are known to be well performing heuristics: (1) the single index dual-base policy (SIDB), which maintains one inventory position with two order up-to-levels (one for each source), (2) the dual index dual-base (DIDB) policy, which maintains two inventory positions and two order up-to levels per source and (3) the Tailored Base Surge (TBS) policy, where a fixed quantity is ordered from the slow source while a single order up-to-level determines the volume ordered by the fast mode. These policies have been proven to be optimal under strict conditions; the SIDB performs optimally when the lead time difference between fast and slow is exactly one period (Fukuda, 1964; Whittemore and Saunders, 1977), the DIDB policy performs nearly optimal (Veeraraghavan and Scheller-Wolf, 2008) or optimal in a robust setting when the slow order is capped (Sun and Van Mieghem, 2017), and the TBS policy behaves asymptotically optimal for long lead times of the slow mode (Xin and Goldberg, 2017).

State-of-the-art dual sourcing replenishment models focus on the daily ordering decision without taking into account the delivery schedule of the slow mode. In practice, however, the frequency of the slow mode is often lower than the fast mode. For instance, a rail connection might only be available weekly whereas trucks can be ordered on the spot market daily, resulting in a mismatch between theory and practice. Dong et al. (2018) reduce the service frequency of the slow mode towards once every two periods. Dong (2017) relaxes the frequency of the slow mode towards once every n periods (assuming zero lead times for the slow mode). However, since a TBS approach is used, both policies require a fixed quantity to be allocated to the slow mode, hence limiting the flexibility for the shipper to alter its replenishment decisions based on the latest demand or the delivery schedule of the slow mode.

2.2 Reinforcement Learning

Reinforcement learning (RL) is a model-free technique in which an agent learns to maximize its future discounted rewards. The agent is characterized by a state $s \in S$, from which it can choose an action $a \in A_s$. RL algorithms, such as the Q -learning algorithm developed by Watkins (1989), are suitable to find optimal action-selection policies for any problem modeled as a finite Markov Decision Process (MDP). More specifically, the Q -learning algorithm aims to find for every (s,a) -pair a Q -value, representing the future discounted reward of being in a state s and from there on selecting greedily the best known actions $a \in A$ at any future state.

As shown by Dayan (1992), Q -learning eventually converges to an optimal policy when all states are visited infinitely often. For large problems, however, this becomes infeasible. An alternative to cope with this challenge is to rely on a neural network to approximate the Q -values. Inspired by the biological neural network, artificial neural nets are powerful tools to effectively interpret large state spaces resulting in many practical applications in various fields such as image and speech recognition or robotics. In combination with Q -learning, a neural net

can be used to approximate the Q -values. More specifically, the neural net can be trained to read the state of the system while outputting the Q -values corresponding to the possible actions in that specific state. We refer the reader to Arulkumaran et al. (2017) and Li (2017) for an overview of the strengths and weaknesses of several recent deep reinforcement learning techniques, and focus in what follows on some specific techniques used in our model.

Mnih et al. (2015) develop the Deep Q -Network (DQN) algorithm (through effectively combining reinforcement learning and Q -learning) and successfully train the algorithm to learn itself to play 49 Atari video games without prior knowledge of the games. Although convergence towards an optimal policy is not guaranteed (in contrast to traditional Q -learning), two manipulations drastically improve the stability of the DQN algorithm. First, experience replay implies a replay memory is kept, in which past experiences are stored. From this replay memory, random samples are drawn to tackle one of the main reasons a neural network diverges: correlation between consecutive states. Rather than taking the last action(s) to update the network parameters, random samples from a memory of past states, actions, rewards and transitions (S_t, a_t, r_t, S_{t+1}) are used to update the neural net parameters. A second modification to improve stability is to introduce target networks. Updating the parameters constantly might cause the algorithm to enter a vicious circle due to the constant updating. To overcome this, a separate target network can be used which is only updated every C iterations. Van Hasselt et al. (2015) show that DQN consistently overestimates the Q -values. Through letting the target network select the best action but approximate the respective Q -value through using the main Q -network, however, this effect can be reduced, resulting in a variant of DQN: double DQN.

In contrast to previous models such as IBM's deepblue and IBM's Watson that require custom-fit rules (Campbell et al., 2002; Ferrucci et al., 2010), the above-mentioned algorithms are suitable to train themselves in many diverse environments without prior knowledge of the problem making them suitable in many domains such as logistics. Oroojlooyjadid et al. (2017) and Oroojlooyjadid et al. (2016) are among the first to develop deep supply chain reinforcement learning models, applied respectively on the well-known 'Beer Game' and the newsvendor problem. Both models report optimal or near optimal behaviour once the artificial agents are fully trained.

3 Smart replenishment model

3.1 Problem statement

We develop a smart replenishment model based on reinforcement learning techniques to optimize the replenishment process of a distribution center, where multiple transport options are available, each with different cost and transport lead time. On a daily basis it has to be decided how much to order through each of the available transport modes. A large shipper in the consumer goods sector, combining road and railway transport for its European transport, inspires the problem. Whereas traditional heuristic policies only moderately take into account the pipeline inventories (for instance by using the inventory position, i.e. the sum of inventory on hand and inventory in transit), we include the full delivery schedule of the pipeline inventories. Based on this full position, we aim to approximate the future discounted costs to develop a (near-)optimal synchronized multi-modal replenishment policy.

Once the model is fully trained, our algorithm provides for every specific state of the system a replenishment action to take. In practice, transport planners will thus receive every review period a proposal how much volume to send by the fast and the slow shipping option.

3.2 Modeling structure

We model our problem as a finite Markov Decision Process, characterized by the 4-tuple $(S, A, R(s, a), \gamma)$. The state space vector (S) includes inventories (both on hand and in transit), the action space vector (A) includes the ordering quantities per transport mode. The reward function (R) maps the costs of taking action a while in state s and the discount factor γ , lastly, discounts future costs. Note we do not include a transition function of the MPD, as we aim to develop a model to work in a model-free environment, i.e. without knowledge of the demand distribution. Instead, we develop a model trainable by sampling from historical demand data or generated by a distribution without feeding the distribution itself to our algorithm.

With L_s representing the lead time of the slowest mode, which we assume to be deterministic, we can characterize our state space vector as a $1 \times (L_s+2)$ matrix

$$S = [I^{(0)} \quad I^{(1)} \quad \dots \quad I^{(L_s)} \quad D], \quad (1)$$

where $I^{(0)}$ represents the inventory on hand, $I^{(i)}$ the inventory in transit to arrive i periods from now, and D the day of the week. The day of the week is added such that the availability of the slow mode can be incorporated (by for instance only allowing slow replenishments on Monday) and the demand can be sampled from the correct day of the week in case the demand is not stationary during the week, for instance because of peak demand during the weekend. Note that we assume the frequency of the slow mode to be smaller than or equal to the frequency of the fast mode, which we fix to be one replenishment per period. If a shipper has the possibility to use two transport modes to place orders (a fast and a slow option), the action matrix can be written as a 1×2 matrix:

$$A = [a^{(f)} \quad a^{(s)}], \quad (2)$$

where $a^{(f)}$ and $a^{(s)}$ represent the amount ordered by the fast and slow mode.

The reward of our model, incurred when taking action a_i (with i indexing the number of possible actions being combinations of $a^{(f)}$ and $a^{(s)}$) and transitioning from s_t to s_{t+1} , consists of transport and inventory costs. The transport costs per shipped unit are c_f and c_s for the fast and slow mode respectively; the inventory costs consist of holding costs (h) per unit positive inventory on hand, backlog costs (b) per unit negative inventory on hand (with a negative inventory equivalent to the number of backorders assuming no lost sales), and pipeline inventory costs (p) per unit ordered but not yet delivered due to the transport lead time. The cost during period t of taking action a_i in state s_t is represented by the reward $r(s_t, a_i)$:

$$r(s_t, a_i) = c^f a_i^{(f)} + c^s a_i^{(s)} + h[I_{t+1}^{(0)}]^+ + b[I_{t+1}^{(0)}]^- + \sum_{i=1}^{L_s} pI_{t+1}^{(i)}. \quad (3)$$

The objective of our model is to minimize the future discounted costs, which can be represented as follows:

$$\min r_1 + \gamma r_2 + \gamma^2 r_3 + \dots + \gamma^{t-1} r_t + \dots, \quad (4)$$

with $\gamma \in [0, 1]$ representing the discount factor and r_t the reward at period t .

Calculating the future discounted rewards is not straightforward due to the stochastic demand, hence it is uncertain to which state we will transition after taking a certain action. Moreover, the time lag between ordering and arrival of inventory further complicates the problem, making the problem intractable for larger lead times.

3.3 Problem complexity

Our problem complexity increases for larger transport lead times of the slow mode and order volumes of both modes: increasing the lead time of the slow mode increases the length of the state vector, while increasing the order size increases the potential number of realizations of our state vector and action vector. Denoting $|S|$ and $|A|$ as the number of state and action realizations, O_f and O_s as the maximum order size of the fast and slow mode, then

$$|S| = L_f \times (O_f + O_s) + (L_s - L_f) \times (O_s), \quad (5)$$

$$|A| = O_f \times O_s. \quad (6)$$

The number of Q -values that need to be approximated is then $|S| \times |A|$. To cope with this complexity, we develop a Q -learning model to estimate our Q -values, representing the total discounted cost of choosing an action in a certain state. Even though the complexity of our problem increases with increasing lead times of the slow mode, through using reinforcement learning we do not suffer from the curse of dimensionality which causes the problem to become intractable for large lead times when using traditional dynamic programming methods.

3.4 Core of the algorithm

After defining our problem as a finite Markov Decision Process, we are able to develop a reinforcement learning algorithm to find an optimal (or near-optimal) state-action selection policy. In other words, a policy that selects, given any state s , the action a_i minimizing the future discounted costs. Our algorithm should thus be able to generate the corresponding Q -values ($|A|$ in total as there is one for each possible action) based on the state of the system (the inventory vector and day of the week). Greedily selecting the action corresponding to the lowest Q -value will then result in our multi-modal replenishment policy.

To find the Q -values, we develop a neural network where the first layer possesses $L_s + 2$ input neurons, corresponding to the length of the state vector. The final layer of the network consists of $|A| = O_f \times O_s$ neurons, corresponding to the number of possible actions. The number of hidden layers, their widths and activation functions are not predefined but problem specific. In Section 4 we discuss one lay-out applicable for a specific case study. Once the lay-out of the neural network is finalized, the algorithm can be initialized and trained. Training implies the weights of the neural net are adapted to bring the output values of the neural net closer to the discounted costs. Since the algorithm is training itself through reinforcement learning, the algorithm has to generate states, choose actions, observe rewards and update the Q -values. Generating states is done through simulating forward in time. More specifically, we update our state space inventory vector as follows when transitioning from period t to $t+1$: first the pipeline inventory to arrive the next day (I_t) is added to the inventory on hand (I_0), the pipeline inventories (I_2 until I_{L_s}) are shifted one day and the day of the week is changed towards the

next weekday. Second, the unknown demand (sampled from historical data or generated from a distribution) is reduced from the inventory on hand, and lastly the pipeline inventories (I_{L_f} and I_{L_s}) are increased corresponding to the ordered quantities, dependent on the selected action. Picking actions in each state is done using an ε -greedy approach, a simple yet effective method to cope with the traditional trade-off between exploring new actions or exploiting known actions. One forward simulation provides us with the 4-tuple $(s_t, a_t, r(s_t, a_t), s_{t+1})$.

Algorithm 1 shows the steps of our reinforcement learning algorithm. Based on the pioneering models of Mnih et al. (2015) and van Hasselt et al. (2015), we integrate (1) experience replay, (2) target setting and (3) double Q -learning to improve stability of our algorithm, techniques explained in Section 2. The algorithm consists of an initialization phase, where the replay memory is initialized, an initial state is chosen and two neural networks are created: one which is updated every iteration (characterized by parameter set θ) and a target network which remains frozen for a fixed number of iterations (with parameter set θ^-). After initialization, we simulate N steps forward while using an ε -greedy approach to trade-off between choosing the best known action (i.e. lowest cost) $\operatorname{argmin}_{a \in A} Q(s_t, a; \theta)$ with probability $(1-\varepsilon)$, or a random action otherwise. All N simulation steps are then added to the replay memory. Next, we sample random minibatches including K experiences from the replay memory and use this to update the weights of our neural network. More specifically, we first calculate the target values for every element of the minibatch using the dueling Q -network approach of van Hasselt et al. (2015): $y_j = r_j + \gamma Q(s, \operatorname{argmin}_{a' \in A} Q(s_{j+1}, a'; \theta^-), \theta)$ using the parameter set θ^- of the target network to choose the best action but using θ to approximate the Q -value. After setting the target values, we use Adam optimizer to minimize the loss, being the mean square error $\sum_{j \in K} (y_j - Q(s_j, a_j; \theta))^2$. Developed by Kingma and Ba (2015), Adam is a gradient descent based optimizer combining the strengths of the Adaptive Gradient Algorithm and Root Mean Square Propagation. One of the main advantages of Adam is that it requires little tuning of the hyperparameters. Lastly, every z iterations, the weights of the target network are replaced by the weights of our first network.

Algorithm 1 Deep Reinforcement Learning (DRL) algorithm

- 1: Initialize replay memory D to capacity ϕ
 - 2: Initialize Q -network with random weights θ
 - 3: Initialize Target Network \hat{Q} with weights $\theta^- = \theta$
 - 4: Choose Initial State s_1
 - 5: **for** $t = 1, T$ **do**
 - 6: **for** $n=1, N$ **do**
 - 7: $a_t = \begin{cases} \text{random action,} & \text{with probability } (1 - \epsilon) \\ \operatorname{argmin}_{a \in A} \{Q(s_t, a; \theta)\}, & \text{else} \end{cases}$
 - 8: Simulate using a_t and observe reward r_t and next state s_{t+1}
 - 9: Store (s_t, a_t, r_t, s_{t+1}) in replay memory D
 - 10: **end for**
 - 11: Sample random minibatches of size K from D
 - 12: **for** $j = 1, K$ **do**
 - 13: $y_j = \begin{cases} r_j + \gamma Q(s, \operatorname{argmin}_{a' \in A} Q(s_{j+1}, a'; \theta^-), \theta), & \text{if } (s, a) \text{ in sample } j \\ Q(s_j, a; \theta), & \text{else} \end{cases}$
 - 14: **end for**
 - 15: Minimize loss = $\sum_{j \in K} (y_j - Q(s_j, a_j; \theta))^2$ using Adam optimizer
 - 16: Every z steps, update Target network $\hat{Q} = Q$
 - 17: **end for**
-

4. Numerical experiment

4.1 Setting

We test our algorithm for a distribution center that receives daily incoming orders from its customers. On a daily basis, the distribution center can order from the manufacturing plant, using either a fast shipping mode (road transport) with frequency one or a slow shipping mode (rail transport), also with frequency one (to be able to compare with existing policies). The numerical parameters are provided in Table 1.

Table 1: Numerical Settings.

Numerical Settings						
h	b	p	L_f	L_s	c_f	c_s
2	38	1	3	7	75	50

The objective of our algorithm is to find a policy that provides us with an action for every state of the system, which minimizes the future discounted costs. In other words, based on the current inventory on hand, the location of all pipeline inventory and the day of the week, a decision should be taken to trade-off holding, backlog, pipeline and transport costs.

Our neural network contains several hyperparameters that need to be tuned to get good performance, a challenging task as individual hyperparameters can influence each other. To find good performing settings for our specific numerical experiment, we use a genetic algorithm to compare various settings, keep the best and explore new ones through selection and mutation. While the input and output layer are fixed to the length of the state vector and the number of actions, the hidden layers, their widths and activation functions need to be specified. We use two hidden layers with respective widths seven and four, each block with a rectified linear unit as activator. Next, the size of the minibatches is set to 1000, while the minibatches are being sampled from a replay memory containing 100,000 experiences. Each time we simulate, 10 forward passes are made replacing the oldest experiences, using an exploration rate ϵ of 5% which remains constant during the training. The target network is kept frozen for 10 iterations (being 10 times 10 updates on a minibatch of size 1000). We use Adam optimizer with learning rate 0.01, first momentum 0.9 and second momentum 0.99.

Once the model is built, we have to feed our model with demand data to start training. For testing purposes, we generate the demand data based on a uniform distribution on an interval between 0 and 5 units ($U(0, 5)$) daily. After feeding our model with the generated data, we let our model train. One training epoch includes sampling of a minibatch and fitting the weights of the neural network to minimize the loss defined in Algorithm 1.

4.2 Training

Figure 1 plots the cost performance of our algorithm during training. This is done through simulating 1000 periods picking the actions corresponding to the lowest Q -value in any state. The more epochs (or training iterations), the lower the cost. Although we notice a sudden increase in performance from the start, the model oscillates heavily with changes in cost performance up to 40%. After approximately 600 training epochs, however, our algorithm converges. Nonetheless, some oscillations remain, caused because of several reasons. Sampling minibatches might cause the weights to be updated to better reflect the minibatch but hurt the performance overall. This effect decreases when increasing the size of the minibatch. In the extreme case of minibatches of size one (known as stochastic gradient descent) for instance, oscillations are much higher. Another reason for the oscillations is inherent to the used

optimizer, Adam adapts the learning rate which can cause to overshoot a little when the learning rate is high. Nonetheless, after 1000 training epochs we reach a policy outperforming three out of four of the benchmark policies, as shown in the next section.

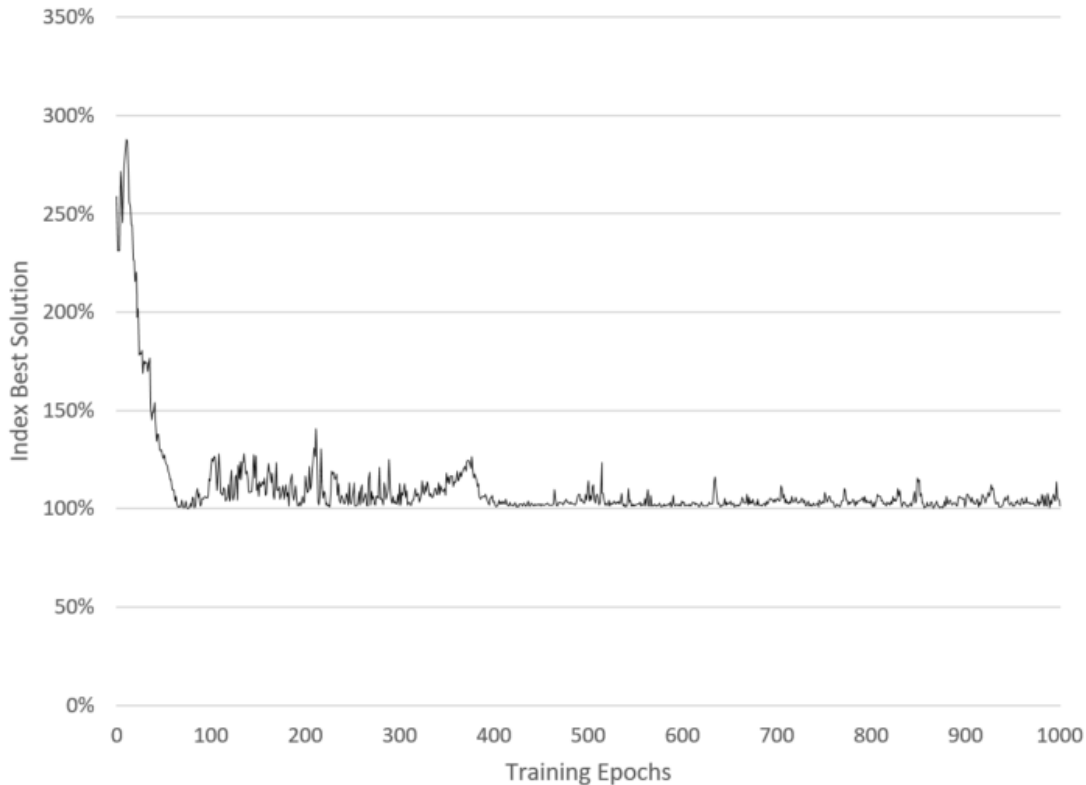

Figure 1: Cost performance during training.

4.3 Benchmark

We compare versus three commonly used well-performing heuristic policies: the Single Index Dual Base (SIDB), the Dual Index Dual Base (DIDB) and the Tailored Base Surge (TBS) policy, introduced in Section 2. These policies have been proven to perform optimal or near optimal under strict circumstances. Nonetheless, an optimal solution is not found for every general setting, mainly because of the insufficient attention to the position of the inventory in transit. The three above-mentioned policies use the inventory position, being the sum of inventory in transit (independent on delivery schedule) and the inventory on hand. This leaves room for error as inventory to arrive soon is more likely to avoid a stock-out compared to inventory to arrive next week. Moreover, we add the newly introduced Capped Dual Index Dual Base of Sun and Van Mieghem (2017), a policy proven to be optimal in a robust setting.

Figure 2 compares our reinforcement learning algorithm (DRL) with the state-of-the-art policies and shows how our algorithm outperforms three out of four benchmark policies. In terms of costs we notice savings of 4.03%, 0.19% and 0.07% compared to respectively the TBS, SIDB and the DIDB policy. The CIDB policy, however, performs 0,03% better than our policy. As the CIDB has been proven to be optimal in a robust setting, we conjecture that our algorithm is able to find a near-optimal multi-modal replenishment policy. Moreover, our algorithm is not bound by strong assumptions such as an equal delivery frequency of the fast and the slow transport mode and can as such be applied in a more diverse range of practical settings.

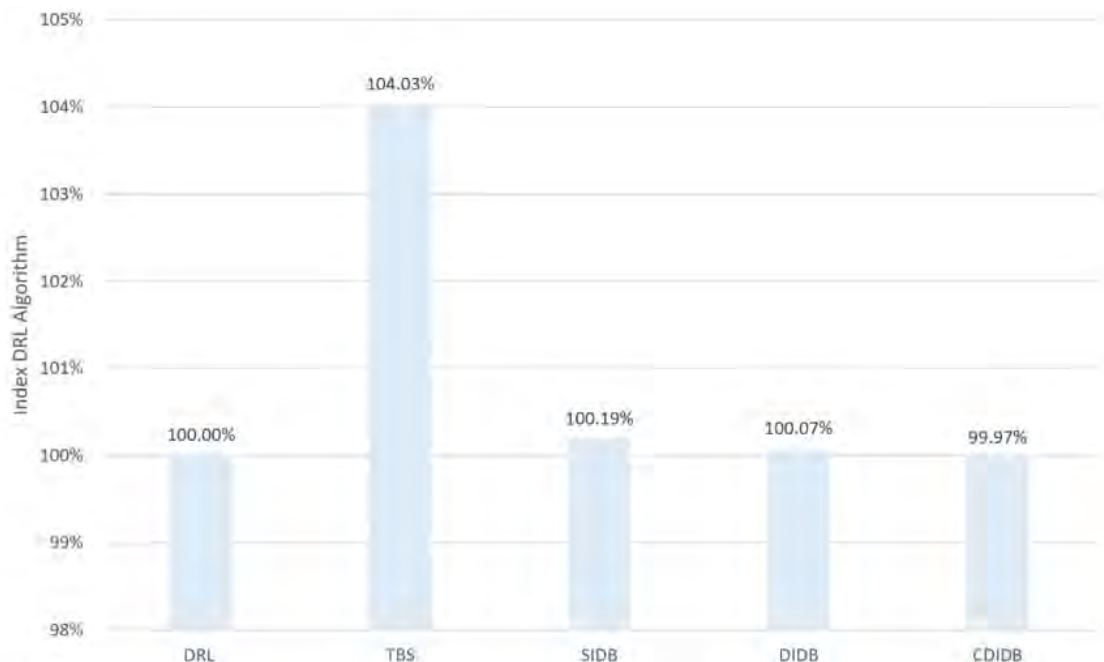

Figure 2: Benchmark with state-of-the-art dual sourcing policies.

5. Conclusion

Recent breakthrough improvements in deep reinforcement learning provide new tools to tackle more complex problems. Through leveraging the power of machine learning, we develop a synchronized multi-modal replenishment model. We compare the performance of our algorithm with state-of-the-art heuristic policies, and show how our model performs close to optimality by taking into account the full delivery schedule of pipeline inventories. Moreover, as we use reinforcement learning, our algorithm is more versatile to include practical limitations such as transport service schedules, allowing to tackle larger and more realistic problems.

6. References

- Arulkumaran, K., Deisenroth, M. P., Brundage, M., and Bharath, A. A., 2017. A Brief Survey of Deep Reinforcement Learning. *IEEE Signal Processing Magazine*, (Special Issue on deep learning for image understanding):1–16.
- Campbell, M., Hoane Jr., a. J., and Hsu, F.-h., 2002. Deep Blue. *Artificial Intelligence*, 134(1-2):57–83.
- Dayan, P., 1992. Technical Note Q-Learning. *Machine Learning*, 292(3):279–292.
- Dong, C., 2017. *A Dual Sourcing Inventory Model for Modal Split Transport: Structural Properties and Optimal Solution*. Dissertation, KU Leuven, Belgium.
- Dong, C., Transchel, S., and Hoberg, K., 2018. An inventory control model for modal split transport: A tailored base-surge approach. *European Journal of Operational Research*, 264(1):89–105.
- Ferrucci, D., Brown, E., Chu-Carroll, J., Fan, J., Gondek, D., Kalyanpur, A. A., Lally, A., Murdock, J. W., Nyberg, E., Prager, J., Schlaefel, N., and Welty, C., 2010. Building Watson: An Overview of the DeepQA Project. *AI Magazine*, 31 (3):59.
- Fukuda, Y., 1964. Optimal Policies for the Inventory Problem with Negotiable Leadtime. *Management Science*, 10(4):690–708.
- Kingma, D. P. and Ba, J. , 2015. Adam: A Method for Stochastic Optimization. In: *ICLR 2015*. Retrieved (<https://arxiv.org/abs/1412.6980>).
- Li, Y. Deep Reinforcement Learning: An Overview. 2017. Retrieved (<https://arxiv.org/abs/1701.07274>).

- Minner, S., 2003. Multiple-supplier inventory models in supply chain management: A review. *International Journal of Production Economics*, 81-82:265–279.
- Mnih, V., Kavukcuoglu, K., Silver, D., Rusu, A. A., Veness, J., Bellemare, M. G., Graves, A., Riedmiller, M., Fidjeland, A. K., Ostrovski, G., Petersen, S., Beattie, C., Sadik, A., Antonoglou, I., King, H., Kumaran, D., DaanWierstra, Legg, S., and Hassabis, D., 2015. Human-level control through deep reinforcement learning. *Nature*, 518:529–533.
- Oroojlooyjadid, A., Snyder, L., and Takáč, M., 2016. Applying Deep Learning to the Newsvendor Problem. Retrieved (<https://arxiv.org/abs/1607.02177>).
- Oroojlooyjadid, A., Nazari, M., Snyder, L., and Takáč, M., 2017. A Deep Q -Network for the Beer Game with Partial Information. Retrieved (<https://arxiv.org/abs/1708.05924>).
- Silver, D., Huang, A., Maddison, C. J., Guez, A., Sifre, L., Van Den Driessche, G., Schrittwieser, J., Antonoglou, I., Panneershelvam, V., Lanctot, M., Dieleman, S., Grewe, D., Nham, J., Kalchbrenner, N., Sutskever, I., Lillicrap, T., Leach, M., Kavukcuoglu, K., Graepel, T., and Hassabis, D., 2016. Mastering the game of Go with deep neural networks and tree search. *Nature*, 529(7587):484–489.
- Silver, D., Schrittwieser, J., Simonyan, K., Antonoglou, I., Huang, A., Guez, A., Hubert, T., Baker, L., Lai, M., Bolton, A., Chen, Y., Lillicrap, T., Hui, F., Sifre, L., van den Driessche, G., Graepel, T., and Hassabis, D., 2017. Mastering the game of Go without human knowledge. *Nature*, 550(7676):354–359.
- Sun, J. and Van Mieghem, J. A., Robust Dual Sourcing Inventory Management: Optimality of Capped Dual Index Policies and Smoothing (November 15, 2017). Retrieved (<http://dx.doi.org/10.2139/ssrn.2991250>).
- van Hasselt, H., Guez, A., and Silver, 2015. D. Deep Reinforcement Learning with Double Q -learning. In *Proceedings of the Thirtieth AAAI Conference on Artificial Intelligence (AAAI-16)*.
- Veeraraghavan, S. and Scheller-Wolf, a., 2008. Now or later: a simple policy for effective dual sourcing in capacitated systems. *Operations Research*, 56(4):850– 864.
- Watkins, C. 1989. Learning from delayed rewards. Dissertation, King's College, UK.
- Whittemore, A. S. and Saunders, S. C., 1977. Optimal Inventory Under Stochastic Demand With Two Supply Options. *Journal on Applied Mathematics*, 32(2): 293–305.
- Xin, L., Goldberg D., 2017. Asymptotic Optimality of Tailored Base-Surge Policies in Dual-Sourcing Inventory Systems. *Management Science*. Retrieved (<https://doi.org/10.1287/mnsc.2016.2607>).



Applying blockchain technology for situational awareness in logistics – an example from rail

Wout Hofman¹, Jacco Spek¹, Christian van Ommeren¹

1. TNO, Soesterberg, The Netherlands

Corresponding author: wout.hofman@tno.nl

Abstract: *improved situational awareness, also known as supply chain visibility, contributes to better decisions with the ability to synchronize processes and reduce costs. It requires data sharing of for instance positions and Estimated Time of Arrival (ETA) of transport means. Blockchain technology could be a means to support data sharing, due to its immutability and transparency. However, transparency might conflict with economic interests of Logistics Service Providers (LSPs): full transparency may disclose customer relations and trade volumes to competitors. This paper presents a Supply Chain Visibility Ledger based on blockchain technology where data sharing can be controlled by a data owner. The Supply Chain Visibility Ledger is illustrated by a case from rail freight transport.*

Keywords: *blockchain technology, distributed ledger technology, supply chain visibility, situational awareness, decision support*

1 Introduction

Hyperconnection or universal connectivity is mentioned as one of the most important aspects of the Physical Internet (Montreuil, Meller, & Ballot, 2013). It encompasses ‘super-fast connectivity, always on, on the move, roaming seamless from network to network, where we go – anywhere, anytime, with any device’ (Biggs, Johnson, Lozanova, & Sundberg, 2012). A hyperconnected world includes all types of devices, e.g. vessels, trucks, containers, and trains. Different sensors and supporting communication technology can be used for the identification and tracking of these devices as a basis to predict behaviour like an Estimated Time of Arrival (ETA) of a train at a next destination (e.g. station, port, terminal). Several research papers have identified supply chains and logistics as the main areas for implementing the closely related concept of the “Internet of Things” (Atzori, Iera, & Morabito, 2010), (Gubbi, Buyya, Marusic, & Palaniswami, 2013). These developments will probably lead to intelligent objects (Whitmore, Agarwal, & Xu, 2015) or what is otherwise known as ubiquitous computing (Weiser, 1991). Cars using the NVIDIA chipset can be treated as hyperconnected computing platforms, thus implementing ubiquitous computing. Automatic Identification System (AIS) with Global Positioning System (GPS) is already used for vessel and barge tracking, trucks have on-board tracking units collecting data through CANbus acting as sensors, and cars and trains have identification mechanisms. The introduction of LoRa technology (www.lora-alliance.org) and 5G (Boccardi, Heath Jr., Lozano, Marzetta, & Popovski, 2014) for communication extends the battery life of sensors and thus their utility for machine-to-machine interaction. The combination of ubiquitous computing and long battery life makes possible the decentralisation of decision making to, for instance, transport means (i.e. autonomous vehicles, trains, vessels, and barges) and cargo, where individual boxes can find their way through a logistics network like individuals.

Large scale data integration is required to achieve state awareness (McFarlane, Giannikas, & Lu, 2016), also known as situational awareness (Endsley, 1995). Hyperconnectivity only addresses the communication level of data sharing and potentially the syntax level, but not the

semantic – or pragmatic (process) level (Wang, Tolk, & Wang, 2009). Furthermore, existing literature (Choudry, 1997) shows that many data sharing solutions are imposed either by dominant players on their suppliers or customers (‘electric monopoly’) or constructed as community solutions like for ports and airports (‘multilateral inter organizational information systems’), resulting in many bilateral implementations (‘electronic dyads’). These solutions are not scalable in the sense that many enterprises can simply implement one solution and be able to share data with all other relevant enterprises. Conceptual interoperability (Wang, Tolk, & Wang, 2009), which has not been implemented by supply and logistics stakeholders so far (The Digital Transport and Logistics Forum (DTLF), 2017), is a necessary requirement for large scale interoperability, complementing hyperconnectivity.

It is in this context that we consider blockchain - or distributed ledger technology which has received an immense amount of attention and investment in the last years. This paper explores the capabilities of BCT as a means to contribute to situational awareness and decision support by autonomous agents by creating a Supply Chain Visibility Ledger. This paper does not further elaborate BCT and its main features. First of all, a logistics scenario utilizing a blockchain is described as a basis to identify challenges, secondly the state of the art of blockchain technology is presented. Finally, the paper will provide a solution for implementing the logistics case.

2 Rail freight transport visibility

This section introduces the case for rail freight visibility as a basis to formulate requirements to its implementation.

2.1 The case

The case describes the transport of containers by a Logistics Service Provider (LSP) from the Rotterdam port by rail to the hinterland in Germany. The chain consists of transport from a sea terminal (‘loading location’) by rail to a yard for train composition (‘terminal 1’). The train operated by a Railway Undertaking (RU) has a slot to Germany, where the locomotive is changed at terminal 2 for transport by rail to the final station (‘unloading location’). At the unloading location, truck drivers will be ready to pick up the containers and drive them to the final destination. Disruptions can occur for each leg, leading to delays and increased waiting times of these truck drivers.

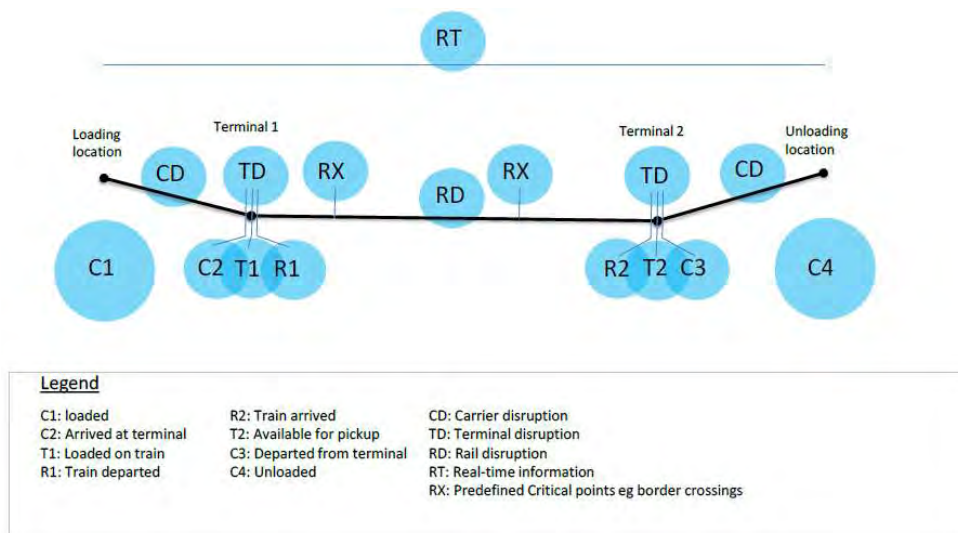

Figure 1 Milestones required by an LSP

The LSP requires a number of milestones from its RU to be able to monitor the progress of logistics operations and to synchronize between the various legs. For instance, a truck will have to pick up a container or trailer at a station for transport to its final destination. In case of delays of rail transport, a driver has to wait or, based on visibility, the LSP can inform the carrier of this delay. Visibility will prevent unnecessary waiting times and potential fines caused by delays.

The next figure shows an event data structure for sharing milestones of physical and administrative processes. These milestones refer to a physical object or data set, e.g. a consignment note, a trailer or a wagon. Milestones are either measured by sensors that for instance an LSP has attached to its trailers loaded on wagons or are provided by or extracted from data sets of another actor.

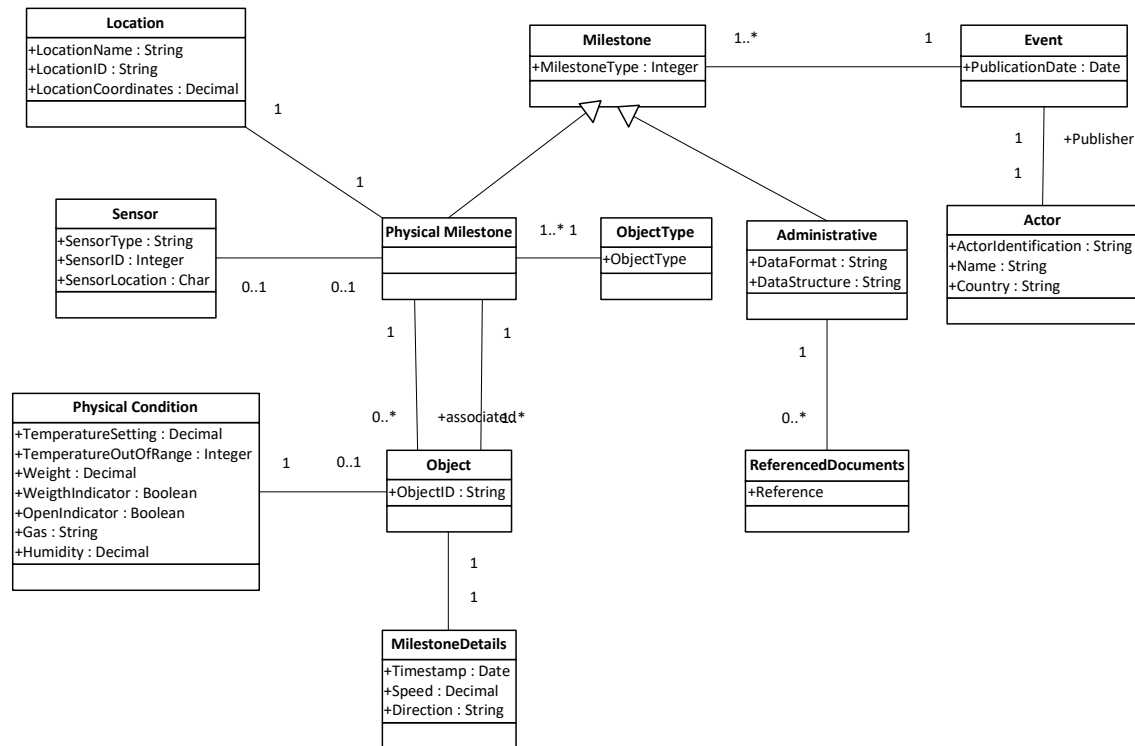

Figure 2 Conceptual data structure of events (UML class diagram)

Each of the stakeholders involved will have a different view of the transport. For instance, a shipper will be interested in the cargo, a forwarder in the loading of the cargo in a trailer that is transported on a wagon, and a Railway Undertaking in a train. Each stakeholder will therefore also require different milestones, e.g. a shipper requires acceptance of the cargo by the first carrier, an estimation of delivery by the final carrier, and the actual arrival and Proof of Delivery to initiate invoicing. The following figure shows the basic concepts of objects for which milestones can be shared. For instance, the association of cargo and equipment represents ‘load’ or ‘discharge’. Similarly, these milestones represent the association between equipment and a transport means.

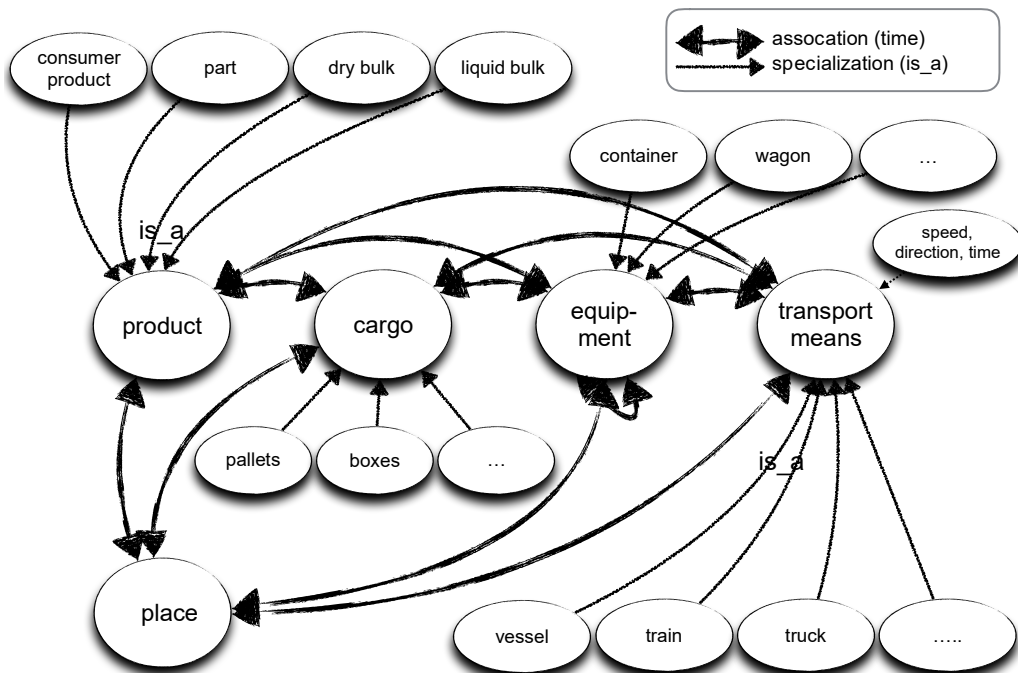

Figure 3 Objects and their associations

Administrative milestones represent the outcome of software like prediction algorithms producing an Estimated Time of Arrival (ETA) of a train at its destination, the Estimated Time of Departure (ETD) of a vessel from a port of call, or a Transport Management System producing a consignment note with its reference.

2.2 Requirements

A train may call upon various stations according a timetable, where at each station containers of different customers (e.g. LSPs) can be loaded or discharged on wagons of the wagon set of that train. It implies that the composition of a train may change at each station (i.e. in terms of its wagon set). Each customer should only be aware of its containers transported by a train and not those of others. Each LSP should be able to follow only its container and not those of their competitors using the same trains. Thus, the following basic requirements can be formulated:

- **Granularity.** There are different levels of granularity distinguished. For instance, an LSP requires to track a container, an RU a train and its wagon set, and an IM a train along a path according a timetable. Both the RU and the IM need to know the train composition; the LSP just requires knowing the position of its container and the progress of the transport activity.
- **Economic sensitivity.** An LSP should not be aware of cargo of their competitors on wagons of the same train. Having this data would allow LSPs to derive trading patterns. This relates to economic sensitivity (Eckartz, Hofman, & Veenstra, 2014).
- **Internet of Things.** Besides organisations and individuals, also assets and cargo can generate data. For instance, a train can provide its position, speed, and direction, which can be the basis for calculating an Estimated Time of Arrival (ETA) at a terminal.
- **In control of data.** An owner should be able to control the access to its data. We distinguish three types of data access. The first is that of an asset owner that has access to data generated by its assets. The second is that of a customer with a commercial transaction

with a service provider. A customer is for instance interested in the ETA of its cargo at the destination than can be provided by a service provider transporting the cargo. The third is that of process synchronisation between for instance a terminal and a carrier, where there is not a commercial relation. A terminal can for instance use an ETA of a train to synchronize its internal processes and to reduce waiting times. The latter requires a publish/subscribe protocol (Erl, 2005).

- Open logistics network. There are many LSPs, RUs and IMs that have business relations changing over time. Business relations between RUs and IMs are quite stable, they depend on the operation of a train over an infrastructure and requires path allocation. However, LSPs may use different RUs and carriers of other modalities and these RUs and carriers operate for multiple customers. Business relations are transaction based, although some LSPs and RUs may also have framework contracts (Williamson, 1975).
- Trust. There are different levels of trust. In this particular requirement, we refer to trust as to which stakeholders are joining a blockchain application. It relates to utilizing a permissioned blockchain, where users are only allowed to join according particular governance rules. These governance rules may impose the provision of assertions that can be validated. These mechanisms are supported by blockchain networks like Sovrin, based on Decentralized Identities (DID).
- Data quality. Trust also involves a guarantee to a data recipient with respect to data quality (Batini & Scannapieco, 2016). It can be expressed in completeness (are all relevant milestones stored and accessible), correctness (is the data correct according to its specification and does it reflect the physical reality), its currency (near real time sharing that a container has been), and consistency (in case two sources provide data of the same milestone, is this data identical). Especially, correctness and consistency are difficult to validate. Correctness of data against specification is feasible, but validation against physical reality requires cross-validation with previous data sets and evaluate of the proposed situation is feasible. A simple rule is for instance that a container cannot be at two locations at the same time.

Of course, there will be additional requirements to an implementation of visibility by blockchain technology like performance (number of events added to a blockchain per second) and scalability (the number of nodes of the blockchain and the number of participants).

3 Implementation of visibility with blockchain technology

Due to its nature, blockchain technology provides full transparency to all users, provides an immutable data set, and offers non-repudiation functionality based on consensus and mining algorithms. However, the case illustrates that complete transparency is not required. This section describes the evaluation of different blockchain technologies to meet the requirements of the case and proposes a solutions. Firstly, the use of smart contracts with private blockchain networks is explored, secondly, that of channels or constellations, and third a cryptographic overlay on existing BCT.

3.1 Smart contracts and private blockchain networks

Nick Szabo initially coined the term “smart contracts” as “a set of promises, specified in digital form, including protocols within which the parties perform on these promises” (Szabo, 1996). He exemplified this by using the analogy of a vending machine. The vending machine takes in a coin and via an automated mechanism (that is trusted by the user) the machine dispenses change and product in a fair manner. In blockchain terms, a smart contract is essentially nothing more than software code. Each node of a blockchain network hosts this code. When a smart contract is called all nodes in the network will execute the logic and record the result. Bitcoin

is a good example. A Bitcoin transaction is the execution of a smart contract that verifies whether you have sufficient funds and whether you are indeed the owner of these funds. If these conditions are satisfied the smart contract will process the transaction and record the change in balances in the ledger (Chainfrog Oy, 2017).

Smart contracts, thus, offer functionality that goes beyond storing and sharing information. It allows for a degree of validation, a number of data validation checks to verify the quality of incoming data, and a degree of automation, completing a process if the verification succeeds.

In supply and logistics, there are many imaginable use cases for smart contracts. For instance, an Infrastructure Manager (IMs) might deploy a smart contract that automatically assigns slots to Railway Undertakings (RUs) providing the correct documentation. Another example is that an LSP is able to derive the ETA of its cargo from the ETA of the train for transport of the cargo. This satisfies the trust -, granularity – and open logistics network requirements of our case, but not the one of economic sensitivity. Smart contract are powerful in protecting data quality and guaranteeing execution of business logic, but they are not suited to control data access.

Ethereum is the most well-known BCT for smart contract applications. It is used to construct an unpermissioned, public blockchain network. This does not only mean that anyone can call a smart contract on Ethereum, but it also means that all data resulting from the successful execution of a smart contract can be retrieved by anyone. It is possible to implement a private Ethereum network for supply chain visibility and only permit access to those users that you wish to share data with. However, creation of a private blockchain network does not meet the requirement of an open logistics network, where business relations are created for cargo flows. An RU transports containers on behalf of multiple LSPs, and therefore has the need to share information with multiple LSPs. An RU could create a blockchain network per business relation, which requires a lot of additional effort for configuration. If all LSPs have access to a blockchain network for their business relation, they would have to integrate with all these networks.

Although smart contracts do not meet all business requirements, it does not mean that smart contracts cannot be used. We propose to use smart contracts for the implementation of granularity and (partly) data quality validation, on top of the solution of choice. One of the drawbacks with Ethereum or its variants is the relative unstable software language, Solidity. The language is changed regularly leading to new versions of the compiler. Testing smart contracts requires the proper compiler.

3.2 Channels or constellations

One of the first technologies developed to keep data private on a public blockchain network were ‘channels’. This solution was initially proposed by Hyperledger Fabric and later also implemented by Quorum as “constellations”. Alternative solutions similar to these are known as ‘multichain’ technologies.

In Hyperledger Fabric a channel is defined as “a private subnet of communication between two or more specific network members, for the purpose of conducting private and confidential transactions” (Hyperledger, 2017). When executing a transaction on Hyperledger Fabric it is possible to specify the channels that are to be used for the transaction. Each channel has a separate, independent ledger, and a node may host one or more channels. In our example, an RU publishing status information about containers may do so in individual channels with each of the relevant LSPs. In this case, channels function as a type of private blockchain network.

Quorum, an Ethereum variant, has a slightly different implementation. A constellation is described as “a peer-to-peer encrypted message exchange for directed transfer of private data to network participants” (JPMorgan Chase, 2018). A constellation is similar to a channel, based on encryption methods. Transactions can be marked as private, are encrypted, and published on the public blockchain. Only peers that can decrypt the transaction will execute the smart contract (Myland, 2017). This creates an inconsistency in the state of different nodes, as some nodes execute private transactions and others do not. This is a problem, because it violates the trust premise of blockchain: all nodes should report an identical state. In Quorum, currently, only public transactions are validated. Validation of private transactions will have to be addressed in the future.

At first sight, Hyperledger Fabric and Quorum seem to satisfy the requirements of trust and economic sensitivity. However, there are some drawbacks to these solutions. First of all, one of the main advantages of blockchain is immutability and non-repudiation. This is achieved by duplication data across numerous nodes. Hyperledger channels cause fragmentation of the network and there is no way trusting the data on another node if yours goes down without a third node to verify the validity of data of the second node. Quorum partly solved this problem by keeping all data in encrypted form on the public blockchain. However, exactly because blockchain technology requires all nodes to report the same state, private transactions cannot be verified. Therefore, you have no way of verifying that the result of a private smart contract transaction is the same on all nodes that were able to decrypt the transaction. Secondly, a channel has to be configured statically and cannot be created dynamically. Thus this mechanism is not able to address the requirement for an open logistics network.

Both Hyperledger Fabric and Quorum are still in experimental phases and offer some challenges towards scalability.

3.3 Sharing decrypted data via a blockchain

Where hashing is a one-way deterministic encryption of data that is useful for pseudonymization of identifiers, one could also encrypt data and make it unreadable. Two mechanism can be applied at the same time, namely symmetric and asymmetric encryption. In symmetric encryption algorithms, the same key can be used to encrypt and decrypt data. By encrypting a symmetric key with a public key of a recipient using an asymmetric algorithm like PGP (Pretty Good Privacy), only the private key of the recipient can be used to decrypt the symmetric key. PGP allows for encrypting data with multiple known public PGP keys of recipients. The encrypted symmetric key can only successfully be decrypted by any matching private PGP key.

This process is described as:

$$\text{Published Data} = \text{PGP}\{V_R, S\}, E_S\{\text{Data}\}$$

Where

- R intended recipient of the data
- PGP PGP algorithm to encrypt S that can be decrypted by all intended recipients with their private key
- E_S encryption of the data with symmetric key S

The PGP algorithm encrypts the symmetric key for all intended recipients. Depending on the number of recipients, this can be a long string of encrypted symmetric keys. The alternative is to encrypt the data with the public key of each recipient, which may even be a longer string depending on the data size.

The process shows that the data published consists of data encrypted by a symmetric key, whereas the symmetric key is encrypted by PGP for all intended recipients. The Published Data is stored in a blockchain network, in our proposal constructed with BigChainDB. Before data can be published, a list of intended recipients should be selected. Those recipients will be able to decrypt the symmetric key and thus the data.

Decryption is in two steps. The first step is decryption of the symmetric key S with the private key of a recipient and the second step the decryption of the data:

$$S = PK_R \{PGP \{V_R, S\}\} \quad (1)$$

$$Data = D_S \{E_S \{Data\}\} \quad (2)$$

Where

PK_R the private key of a recipient

PGP PGP algorithm to encrypt S that can be decrypted by all intended recipients with their private key

D_S decryption of the encrypted data $E_S \{Data\}$ with symmetric key S

Recipients have to listen to data added to the blockchain, but only those recipients are able to decrypt the symmetric key and thus the data, that have the proper private key.

3.4 Supply Chain Visibility Ledger

The last solution meets all requirements mentioned before and requires development of additional software code, similar to code that has to be developed in the other cases. The solution enables publishers to make data available only to intended recipients (economic sensitivity) and enables various stakeholders to dynamically configure their publication and subscription mechanisms (open logistics network). Trust is currently based on the cryptoIDs of each stakeholder. Using permissioned BCT allows to manage these cryptoIDs. Data quality is not yet validated in the proposed solution, it handles all types of data between any publisher and recipient(s).

The current implementation of the blockchain only supports sharing physical milestones with events. BigChainDB is applied as blockchain technology. BigChainDB already store data in an encrypted way, based on the private key of the user storing data on the blockchain. It ensures that a recipient can verify the identity of the one storing the data. Blocks are hashed just like other BCTs do and stored in a database like MongoDB. BigChainDB can integrate with existing BCT technologies like Ethereum and Hyperledger and provides a set of Application Programming Interfaces (APIs) (BigchainDB GmbH, May 2018).

In our prototype, the BigChainDB APIs have been extended to support the required encryption and decryption functionality (section 3.3). To store data of users, a separate database is utilized. It contains the necessary publish/subscribe list, private keys of all users and shared events. This database provides a number of APIs for data manipulation like adding a new recipient to a user. On the blockchain application, everyone or every object can be a user, e.g. a train, a wagon, an Infrastructure Manager and a Railway Undertaking are all users. The publish/subscribe lists represent sharing event data, for instance a train can have a publish/subscribe list for its wagons and the Railway Undertaking operating the train and a wagon can have a list for its load. All users have a listener process to decrypt all events for which they are a recipient. The listener utilizes the 'get messages' API provided by the blockchain application. The APIs for retrieving messages automatically decrypt the symmetric key and the data for the recipient. The following figure provides an example of a user interface for visualizing all relevant events.

The screenshot shows the 'Events' page of the SMART RAIL application. The interface includes a sidebar with navigation options like Home, Contacts, Railway objects, and Events. The main content area displays a table of events. The table has the following columns: Id, Railway object name, Type, Event, Departure station, Departure date, Arrival station, Loading terminal, Destination terminal, Net loading mass, Train number, and Blockchain received date. The data shown is as follows:

Id	Railway object name	Type	Event	Departure station	Departure date	Arrival station	Loading terminal	Destination terminal	Net loading mass	Train number	Blockchain received date
69	33534557175	Wagon	Departure	Faisceau Chalon sur Saone	05/03/2018	PLEH	APROPORT CHALON	ZSP	9	180305CSSLN	2018-03-30T17:04:34.258497+02:00
63	378049936966	Wagon	Departure	Faisceau Chalon sur Saone	05/03/2018	PLEH	APROPORT CHALON	ZSP	12	180305CSSLN	2018-03-29T15:06:19.857997+02:00
62	378049936966	Wagon	Departure	Faisceau Chalon sur Saone	05/03/2018	PLEH	APROPORT CHALON	ZSP	12	180305CSSLN	2018-03-29T14:53:46.610035+02:00
61	378049936966	Wagon	Departure	Faisceau Chalon sur Saone	05/03/2018	PLEH	APROPORT CHALON	ZSP	12	180305CSSLN	2018-03-29T14:14:44.585348+02:00
58	378049937071	Wagon	Departure	Faisceau Chalon sur Saone	05/03/2018	PLEH	APROPORT CHALON	ZSP	12	180305CSSLN	2018-03-29T11:21:24.604532+02:00
57	378049937071	Wagon	Departure	Faisceau Chalon sur Saone	05/03/2018	PLEH	APROPORT CHALON	ZSP	12	180305CSSLN	2018-03-29T11:19:00.310142+02:00

Figure 4 Example of a user interface on the blockchain application

The event data stored in the blockchain can be used for various purposes, e.g. the calculation of the mileage of a wagon as basis for maintenance or the analysis of recurring delay on particular tracks.

4 Proposed extensions to the ledger

This section presents a number of proposed extensions to Supply Chain Visibility Ledger. The basic extensions are: configuration of the publish/subscribe lists and data validation. These will be discussed hereafter.

4.1 Data management rules

In the implementation, the publish/subscribe list of the blockchain application is manually handled via a user interface. Furthermore, the list does not yet contain details on the type of milestones that can be shared amongst different users of the blockchain application. This section proposes generic data management rules for automatic configuration of these lists. The data management rules are:

- **Commercial relations.** A customer is allowed to receive events regarding the cargo objects to be handled by a service provider. The customer, e.g. a shipper, LSP, and forwarder, order a logistics service for particular cargo objects like containers or pallets to be shipped. The configuration of the publish/subscribe list is based on data of for instance a transport – or shipping order. An API could be developed to configure the list from the order. A service provider can provide the following events:
 - **Load** – the cargo is loaded into another object, e.g. pallets are stuffed into a container and a container is loaded on a wagon. The time of loading indicates the time at which responsibility of the cargo (damage, loss) is taken over by the service provider. A load milestone can be given for individual cargo objects or a list of all cargo objects part of a consignment or shipment in the commercial relation.
 - **Consignment note** – an administrative milestone representing the data set of the cargo loaded in or on another object. This milestone contains data of all cargo objects that are part of a consignment or shipment.

- Departure – the transport has started and the cargo objects are on their way.
- Estimated Time of Arrival – the predicted estimated time of arrival of the cargo objects at their intended destination as agreed between customer and service provider. In case the transport operation consists of different transport legs, it is the ETA of the last leg in a chain.
- Arrival – actual arrival of the transport means at the destination agreed between customer and service provider.
- Discharge – the cargo objects are available for further activities at the destination agreed between customer and service provider. At discharge, any remarks with respect to the cargo objects can be given like damage remarks. Discharge and additional remarks can be the basis for triggering payment of rendered services.

In addition to these milestones, a customer might require a milestone like crossing a border, which may lead to potential delays in rail transport.

- Asset ownership. An asset owner like an operator providing the wagons for a train or the owner of a trailer that is transported by train receive the following milestones of the organisation utilizing these assets, e.g. a Railway Undertaking composing a train with wagons of different operators: departure, ETA at the location where the asset will be available after its utilization, and the arrival at that location.
- Process synchronisation. Hubs like terminals and stations can optimize their operation by sharing the following milestones:
 - Discharge – a cargo object is available for the next transport leg in a chain, e.g. it is available for loading on a wagon. The milestone is shared by a terminal to the carrier of the next leg.
 - Estimated Time of Departure – an estimated time at loading and discharge operations will be completed, including any additional operations like bunkering. An ETD will be provided by a hub operator to a carrier. In case of a Railway Undertaking, the wagons are ready to be picked up by a locomotive.
 - ETA – the ETA of a transport means at the next hub, e.g. the ETA of a train at a terminal. The milestone is shared by a carrier with the next hub. It is assumed that the hub operator, e.g. the terminal operator, has sufficient data for discharging and loading particular cargo objects on a train.

A hub operator and carrier like a Railway Undertaking do not necessarily have a commercial relation. In case they have a commercial relation like a terminal operator with shipping lines, they will automatically share the aforementioned milestones. In some cases, a hub operator provides its services

4.2 Data validation rules

In the current implementation, the user interface reflects the proposed event data structure (figure 2). Data is validated according that user interface and all data posted to the blockchain application is inserted to a block. However, APIs should be applied to validate data before it can be posted to a blockchain and added to a block. In this respect, data validation is twofold. Firstly, it considers the validation of data before posting it to the blockchain. The data should confirm to the event data structure (see figure 2). The objects for which data can be posted on the blockchain needs to be according the structure shown in figure 3. The milestones that can be posted should be according a proposed milestone list of physical and administrative milestones. By representing the event data structure as an ontology that can be transformed into for instance JSON-Linked Data (JSON-LD), a JSON validator can be applied to validate the data structure before posting the data.

Whereas the previous validation rules reflect correctness of individual event data, the second data validation rules reflect the representation of physical world. Users can always make errors

in the sense of providing an incorrect identification of a physical object, e.g. a container number. Furthermore, a train may use tracks managed by different Infrastructure Managers. These IMs may provide the milestones of a train at different times. For instance, the IM of the second track may provide a train position at a given time, whereas the IM of the first track can provide a position of the same train at its tracks at a later stage. The timestamp of the position is applied to validate the correctness of both positions. Thus, additional validation rules have to be applied before an event can be added to a block, where these validation rules can be the basis for a mining algorithm. Such a mining algorithm can be optimized by the intended itinerary of a physical object. For instance, an RU may know the paths on the tracks of IMs and the forwarder may know the transport chain with its different legs. The chain is the basis for the itinerary with different legs and hubs, it is the basis for validating events. In case an itinerary is not known, it can be reconstructed based on events with milestones. Validation of completeness of milestones by their sequence and milestone can be performed.

The following validations can be applied:

- Complete itinerary known - received milestones can be linked to the itinerary. The itinerary always refers to one or more objects with at least one leg of a chain (e.g. one transport leg) that cannot further be decomposed. Completeness can only be validated if the itinerary contains all locations and logistics operations (i.e. the milestone) for which a milestone has to be received. Otherwise, completeness cannot be validated. Errors are detected if:
 - A milestone refers to a location and/or logistics operation that does not fit in the itinerary;
 - In case the itinerary also links expected or estimated times to a milestone and the actual time of the milestone deviates, a flag can indicate a potential error.
- Itinerary decomposition. In this case, only the start and end of an itinerary of an object are known, i.e. provided by a shipper to a forwarder. This situation occurs in case of dynamic chain planning, where next legs are planned just before a previous one is completed. Decomposition of the itinerary in a chain with more than one transport leg is constructed based on received milestones. Validation of completeness can only be identified if gaps occur based on missing loading/discharge and arrival/departure events. For instance, a container departs by truck at a place of acceptance and arrives by train at a terminal for loading in a vessel. Transshipment from truck to train is unknown. In this particular example, two carriers (road and rail) did not report their transport legs. Another example is that particular goods are reported to be stuffed in a container and not all goods are stripped from the same container at its destination (or more are stripped). Some stuffing or stripping event is lacking. This type of validation can only be done after the chain is completed, since events with milestones might still be received at a later stage.
- Real-world validation – this comprises cross-validation of data sets of different sources on the existence of real world objects and validation of location and time. In addition, it is assumed that all constraints are validated within a data set (e.g. a container cannot contain another container). Real-world validation can be improved by (trusted) sensor data and physical inspection with feedback to a visibility system.
- Consistency of milestones –this particular validation rule validates that a milestone of an object fits in an itinerary or can logically be part of the decomposition of an itinerary. It will occur since different stakeholders in a chain will produce events with milestones of the same object. Milestones can be submitted, received, and processed out of sequence, meaning that a milestone upstream a logistics chain might be received and processed after receiving a downstream milestone (upstream: further to the start of a chain; downstream: further to

the end). When an itinerary is known in advance, up- and downstream milestones can always be processed, as long as they can be related to the itinerary. When an itinerary is decomposed, validation on location and time (see before: real-world validation – location and time) needs to be performed. Errors can only be detected when the distance between the location in a received milestone cannot be plotted between two milestones that are already processed. Detection of two potential milestones that are already processed, is based on ‘location’ and time:

- in case the location of the received milestone can be plotted on a line between any two locations already known (or a corridor between two locations or alongside a track or inland waterway connecting two locations), then
- if the duration between the time of the received milestone and the upstream one is feasible based on average travel times of a transport modality and the same for the next milestone, then the milestone is consistent; else an error is detected and flagged;
- else an error is detected and flagged.

This particular validation should also consider the case of a container transported to the hinterland from a port and arrive for a different itinerary at the same port, the same day. In case a container returns the timestamp of a milestone reflects a time later than that of the endpoint of an itinerary and a new itinerary is created. Automatically, a new itinerary can be initiated.

- Correctness of milestone data. This particular validation rule considers the fact that there is no itinerary of an object and still events are posted. There are different reasons, e.g. the object identification is not properly assigned (e.g. a container can be short shipped or overlanded from a vessel at a terminal due to such an error). In this case, a human could be able to correct the object identification. Another reason is that a new itinerary of an object has started without initiation of that itinerary. In the latter case, a new itinerary can be initiated.

These type of validation rules need further elaboration, including their implementation by a blockchain application.

5 Discussion and conclusions

This paper proposes a Supply Chain Visibility Ledger based on a use case for rail freight transport. This use case formulates a number of requirements for configuring the distributed ledger. The main requirement, economic sensitivity of data in open organizational networks, leads to the addition of encryption functionality to the APIs of a standard blockchain technology, BigChainDB. The application can easily be applied for supply chain visibility in all modalities and all types of cargo.

This paper discusses two potential extensions of the prototype. The first is to ease the use of the ledger by generic **data management rules**. These rules relate to orders shared in a commercial relationship between a customer and service provider. This order data can be used to configure the publish/subscribe lists of the users of the ledger. Additionally, other authorities than infrastructure managers might be integrated with the distributed ledger, which may imply extensions by including data of physical objects themselves (e.g. customs authorities require data of the contents of containers).

The second extension is **data validation**. Firstly, correct data should be posted to the ledger to enable a recipient to process the data. Secondly, the data posted to the ledger should reflect a real world situation. Potential errors of users with respect to for instance identifications should be detected to improve decisions by a recipient.

There are other topics for further research. The first is on the **transaction rate** and **data volume** of events posted to the Supply Chain Visibility Ledger. BigChainDB has an average transaction rate of some hundreds of transactions per second, also depending on the volume of the data posted. Event data is very small, but applying encryption will lead to larger volumes. To apply the Supply Chain Visibility Ledger for instance to rail freight, the number of wagons, cargo objects, and trains with the required milestones by individual users should be calculated.

The second is on the governance of the application. We have implemented an event data structure that has been developed and applied by two EU funded projects, namely EU FP7 SEC CORE and H2020 SmartRail. This event data structure is the basis for developing the APIs of the Supply Chain Visibility Ledger. It illustrates that the event data structure can be applied. Currently, one node is installed. However, the distributed ledger functionality and its nodes need to be governed. A governance model should be developed for both the implementation and the event data structure underpinning the distributed ledger. By standardizing the event data structure, the implementation can become more open and users can implement the APIs.

Governance is relevant to make a distinction between BCT and traditional integration technology. In applications like presented in this paper, a large number of stakeholders can be users of an infrastructure. Characteristics of the operation of BCT applications is that anyone can install and operate a node in its own domain. The infrastructure is (potentially) operated and owned by all participants, although participants don't have access to all data on their nodes. Each node has to have sufficient data storage capabilities and adhere to particular performance requirements of the network, but the complete network of nodes will still be operational when one third of the nodes fail (BigchainDB GmbH, May 2018). Since all nodes support the same APIs, a user can easily switch to another node. Traditional integration solutions require additional measures with costs, charged to the owners and/or the users. So, a BCT application is more robust. As regards to governance, only the API functionality needs to be agreed amongst all users, similar to a standard (UK Government Chief Scientific Adviser, 2015). By standardizing this functionality and its supporting software code with APIs and implementing maintenance procedures, a governance body common to all users can be relatively small, potentially implemented by a standardization body. The latter requires a clear distinction between conceptual specifications and technical code, where the technical code for a BCT might be developed by third parties. Traditional integration technology not only requires governance of standards, but also governance of the applications. In many cases, dominant players or community want to impose their solutions to users, leading to competitive, incompatible solutions with relative high costs (Hofman, 2018).

Trust is an important topic to address, from two perspectives. The first perspective is that someone connecting to the blockchain can provide proof of his identity, where the proof is provided by an independent, trusted third party. Procedures supported by Certification Authorities and technology should be in place, e.g. a Sovrin blockchain acting as Certification Authority based on Decentralised Identity Scheme developed by the World Wide Web Consortium. Secondly, trust relates to the correctness of the data stored on the blockchain. In this respect the aforementioned data validation rules need to be implemented.

Finally, **logistics blockchains** can provide a variety of functionality. First of all, it can serve as an **interoperability** infrastructure providing standardized APIs (Application Programming Interfaces) with data validation. Each organization can implement these APIs in its own environment. Secondly, it can provide **non-repudiation** as an immutable log of all data shared. Thirdly, the data stored in the blockchain can be used by **authorities** for risk analysis and VAT compliance. It can also be the basis for billing, payment, and, more generic, **supply chain finance**. By distributing data instantaneously to all participants, fourthly, it can improve

situational awareness and thus contribute to decision support required by the Physical Internet. Finally, it can be a basis for **auditing** in case all data relevant to ordering and delivery between enterprises is logged on a blockchain infrastructure. Concluding, BCT looks promising to logistics, but still requires additional research for large scale applicability.

References

- Atzori, L., Iera, A., & Morabito, G. (2010). The Internet of Things: a survey. *Computer Networks*, 54, 2787-2805.
- Batini, C., & Scannapieco, M. (2016). Data quality dimensions. In *Data and Information Quality. Data-Centric Systems and Applications* (pp. 21-51). Springer.
- BigchainDB GmbH. (May 2018). *BigchainDB 2.0 - The Blockchain Database*. Berlin: BigChainDB GmbH.
- Biggs, P., Johnson, T., Lozanova, Y., & Sundberg, N. (2012). Emerging Issues for a Hyperconnected World. *The global information technology report*, pp. 47-56.
- Boccardi, F., Heath Jr., R. W., Lozano, A., Marzetta, T. L., & Popovski, P. (2014). Five Disruptive Technology Directions for 5G. *IEEE Communications Magazine*, 52.2, 74-80.
- Chainfrog Oy. (2017). *What are Smart Contracts?* Retrieved from <http://www.chainfrog.com/wp-content/uploads/2017/08/smart-contracts.pdf>
- Choudry, V. (1997). Strategic Choices in the Development of Interorganizational Information Systems. *Information Systems Research*, 8(1).
- Eckartz, S., Hofman, W., & Veenstra, A. F. (2014). A decision model for data sharing. *eGov2014*. Dublin, Ireland: Springer.
- Endsley, M. (1995). Toward a theory of situation awareness in dynamic systems. *Human factors*, 1, pp. 32-64.
- Erl, T. (2005). *Service Oriented Architecture - concepts, technology and design*. Prentice-Hall.
- Gubbi, J., Buyya, R., Marusic, S., & Palaniswami, M. (2013). Internet of Things (IoT): a vision, architectural elements, and future directions. *Future Generation Computer Systems*, 29, 1645-1660.
- Hofman, W. (2018). Towards large-scale logistics interoperability based on an analysis of available open standards. *IESA2018*. Berlin: Springer.
- Hyperledger. (2017). *Channels*. Retrieved from <http://hyperledger-fabric.readthedocs.io/en/release/channels.html>
- JPMorgan Chase. (2018). *Quorum*. Retrieved from <https://github.com/jpmorganchase/quorum>
- McFarlane, D., Giannikas, V., & Lu, W. (2016). Intelligent Logistics: involving the customer. *Computers in industry*, 81, pp. 105-115.
- Montreuil, B., Meller, R. D., & Ballot, E. (2013). Physical Internet Foundations. In T. Borangiu, A. Thomas, & D. Trentesaus, *Service Orientation in Holonic and Multi Agent Manufacturing Robots* (pp. 151-166). Heidelberg: Springer-Verlag.
- Myland, P. (2017). *Quorum and Constellation*. Retrieved from <https://patrickmn.com/security/quorum-and-constellation/>
- Szabo, N. (1996). *Smart Contracts: Building Blocks for Digital Markets*. Retrieved from http://www.fon.hum.uva.nl/rob/Courses/InformationInSpeech/CDROM/Literature/LO Twinterschool2006/szabo.best.vwh.net/smart_contracts_2.html
- The Digital Transport and Logistics Forum (DTLF). (2017). *An outline for a generic concept for an innovative approach to interoperability in supply and logistics chains*. Discussion Paper, EC DG Move, Brussels.
- UK Government Chief Scientific Adviser. (2015). *Distributed Ledger Technology: beyond block chain*. Government Office for Science.

- Wang, W., Tolk, A., & Wang, W. (2009). The levels of conceptual interoperability model: applying systems engineering principles to M&S. *Spring Simulation Multiconference*. Society for Computer Simulation International.
- Weiser, M. (1991). The Computer for the 21st Century. *Scientific American*(3), 94-104.
- Whitmore, A., Agarwal, A., & Xu, L. D. (2015). The Internet of Things - survey of topics and trends. *Information Systems Frontiers*, 17, 261-274.
- Williamson, O. (1975). *Markets and Hierarchies: analysis and antitrust implications*. New York: Free Press.

Cellular Warehousing for Omnichannel Retailing: Internet of Things and Physical Internet Perspectives

Xin Wang², Xiang T.R. Kong^{1,2}, George Q. Huang² and Hao Luo¹

¹Department of Transportation Economy and Logistics Management, College of Economics, Shenzhen University, Shenzhen, China

²HKU-ZIRI Lab for Physical Internet, Department of Industrial and Manufacturing Systems Engineering, The University of Hong Kong, Hong Kong

Corresponding author: Xiang T.R. Kong, kongxtr@hku.hk

Abstract: Significant expansions have been reflected worldwide in business reports of major E-commerce players such as Alibaba, Amazon and JD.com. Omnichannel retailing is an evolutionary variant of E-commerce by providing consistent, unique and contextual brand experiences across multiple customer-aware touchpoints. Despite all the efforts, goods still move slowly and damages are a concern along with the booming omnichannel retailing. Meanwhile, high variety and variability of omnichannel retailing orders complicate the implementation of automated facilities. To deal with these phenomenal and challenging problems, a new warehousing paradigm named cellular warehousing is proposed. The concept of cellular warehousing is adapted from cellular manufacturing, taking full advantage of the similarities between online-offline orders and/or their items as well as standardization and common processing. To sum up, the paper will firstly introduce the key processes within the IoT/PI-based cellular warehouse, and then cover the major elements to support the operation. Finally, three representative case studies of Alibaba, JD.com and COSCO will be presented to verify the necessity to transform the existing warehouses to cellular warehouses.

Keywords: Omnichannel Retailing, Logistics, Cellular Warehousing, Cellular Manufacturing, Internet of Things, Physical Internet

1 Introduction

Omnichannel retailing refers to combining and integrating various sales channels to meet the comprehensive experience needs of customers' demand on shopping, entertainment and social networking (Piotrowicz et al., 2014; Verhoef et al., 2015; Cummins et al., 2016). These types of channels include tangible and intangible stores as well as the information media such as the websites, emails and the social media (Fei 2013). In the age of omnichannel retailing, the entire supply chain system becomes customer-oriented so that the enterprises are required to put the customers' needs in the core position when designing all strategies and operations such as warehousing operations and goods delivery (Picot Coupey et al., 2016). The customers may place an order consisting of any types of goods at any time in any place by any methods, which sets a quite high requirement on the warehousing operation especially (Cummins et al., 2016). The warehouses are expected to handle the omnichannel orders of large quantities and varieties very efficiently in a short time window to meet the customers' promise such as "same day delivery" or "next day delivery".

The e-commerce enterprises and the logistics players, however, have not kept up the pace of its development of the warehouses, even though the major e-commerce players worldwide have cast a lot of efforts on improving their warehousing performance. For example, Amazon has introduced the Kiva system (Bhasin et al., 2016; Xinhua, 2017) and JD.com has put into use of a highly automatic fulfillment center in China. Whereas, the automatic warehouse is only capable of dealing with the goods of similar properties in terms of sizes and weight.

Considering the challenges, there is an urgent need for an innovative warehousing paradigm. Our paper comes up with the concept called Cellular Warehousing (CW), which is adapted from Cellular Manufacturing (CM). CW will take full advantage of the similarities among the online-offline orders and their items as well as standardization and common processes. A cellular warehouse is composed of multiple cells, each of which is optimized in terms of layout, space, internal scheduling, operations and facilities. The order items with strong similarities are handled in the same cell. To facilitate automating the flow of information, driving the synchronization among the cells and visualizing the operation, Internet of Things (IoT) and Physical Internet (PI) will be applied to build up the technological infrastructure. This article will focus on discussing the concept, building blocks and case studies of the cellular warehousing that driven by PI and IoT technologies.

CM is proposed as the panacea for dealing with more personalized and changeable customer needs; and meanwhile to strengthen the flexibility of production workshop. There have been mature theories guiding the design and operations of cellular manufacturing, which can be taken as reference when designing the cellular warehousing framework. Each stage for implementing CM has been well discussed in theory, including cell formation (Selim et al., 1998; Mahdavi et al., 2009; Gonçalves et al., 2004), the cell layout design (Salum, 2000; Tavakkoli-Moghaddam et al., 2007; Solimanpur et al., 2004) and inter-cell/intra-cell scheduling (Tavakkoli-Moghaddam et al., 2010; Golmohammadi et al., 2009). In the complicated omnichannel retailing environment, demand-driven supply chain also urgently needs a similar warehousing solution to hedge against risks and costs while providing sufficient agility. Although some scholars who have set about discussing similar concepts (Shafer et al. 1993; Huang et al. 2015), there is little research exploring how to match the concepts or theories from cellular manufacturing to cellular warehousing. Also, little literature has formally established the concept of cellular warehousing. The application conditions, constrains, methods, advantages and disadvantages to apply cellular concepts to warehousing have not been discussed, not to mention the verification of the idea.

This research will come up with a preliminary conceptual model of cellular warehousing considering the typical characteristics of e-commerce logistics from the following three aspects. Firstly, the research will examine the matching relationship between CW and CM to bring about CW paradigm. It can be conceived as a primer on the cellular warehousing concept. A generic workflow within a PI/IoT-enabled cellular warehouse will be illustrated. Secondly, key building blocks for PI/IoT-enabled cellular warehouse are introduced in terms of physical dimension and cloud cyber dimension. Finally, through three representative case studies, industrial motivations and current frontiers for CW will be discussed. Future works are also identified for open exploration.

It is expected that a theoretical framework of a cellular warehouse in the context of IoT and PI will be established. The paper aims to make both theoretical and practical contributions to the ecommerce warehousing field. From a theoretical point of view, the study is among one of the early articles to apply cellular concepts to the warehousing design and operation, which might be regarded as a promising research stream. With regards to the practical contribution, the model proposed could serve as a reference for designing new warehouses, which will benefit various stakeholders. By referring to the paradigm, it is possible that the warehouse operator could further improve their efficiency and accuracy when dealing with ecommerce cargo of large volumes and varieties. The logistics automation service provider can possibly figure out new services and earns a higher market share in the future. Last but not least, the customers can be better satisfied with higher service levels and reduced costs

In the following, the paper will firstly introduce the key processes within the IoT/PI-based cellular warehouse, and then cover the major elements to support the operation in section 3. Section 4 will present three case studies of Alibaba, JD.com and COSCO to verify the necessity

to transform the existing warehouses to cellular warehouses. Finally, future works are given in section 5 for open discussion.

2 Key process within a PI-enabled cellular warehouse

In addition to the traditional functions of materials storage, warehouses now are equipped with more functions, including materials receiving, order put-away, picking, sorting, packaging, consolidation, dispatching and etc. By implementing the cellular warehousing with the major support of IoT and PI, the warehouses can achieve these objectives much more efficiently.

The framework of cellular warehousing is composed of the physical warehouse and the cyber decisions to better manage the physical warehouse. These two layers of systems are simultaneously operating based on the philosophy of physical internet and cyber-physical system as well as IoT technological architecture. The processes in the physical warehouse will be reflected in the cyber space that will be monitored by the qualified planners or schedules for global optimization and operational synchronization. Especially, any unusual event in the physical warehouse will be highlighted so that the scheduler will be informed via cyber decision sub-system. Meanwhile, the scheduler can make changes on the parameters or variables of the cyber decisions to dynamic (re)configure the operations of physical warehouse back on track.

A clear insight over the key processes within a PI-enabled cellular warehouse is shown in Figure 1, from the time when the items come into the warehouse until the time when the items are shipped to the customers. The entire process consists of three major stages, inbound, warehousing and outbound. The operations directly related with the items flow take place in the physical warehouse. All the dynamic conditions will be uploaded to the cloud real-timely, which can be accessed by the authorized staff of the warehouse for (re)planning, (re)scheduling and controlling. The instruction on the physical warehouse will be placed through the cloud as well. In a PI-enabled warehousing / cross-docking environment, standardization is a critical premise and fundamental principle in terms of cargo, material handling facilities and even software protocols or data formats. CW is structured and operated based on this environment.

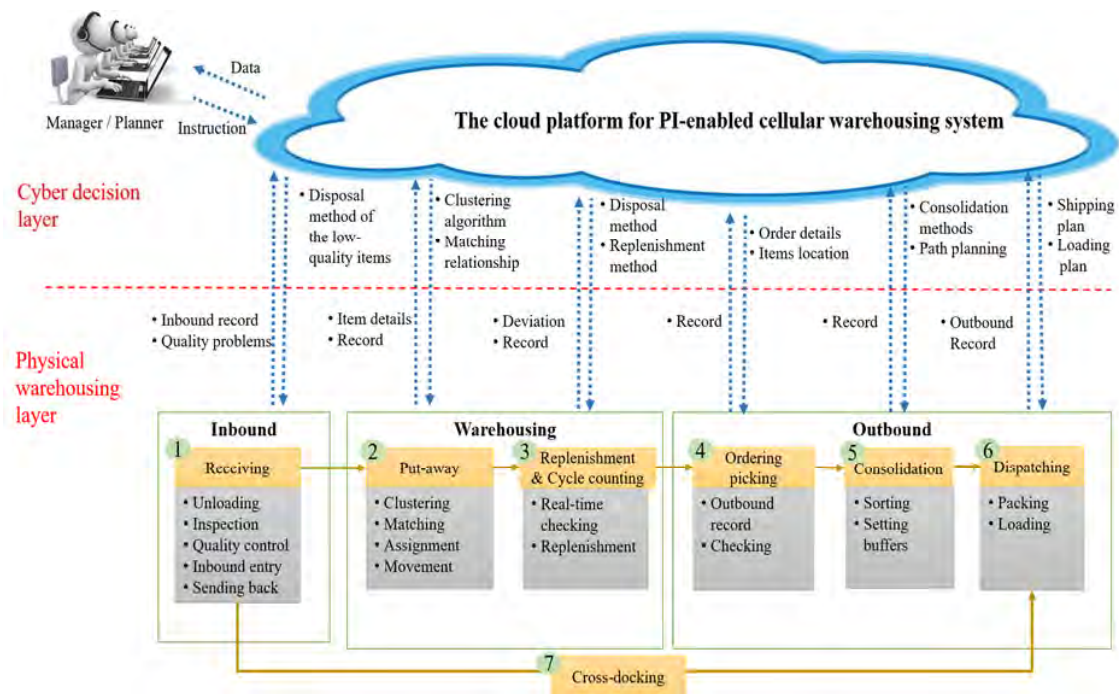

Figure 1: The process within a CPS-based cellular warehouse

The entire CW main stages are illustrated in following 7 steps:

- (1) CW begins with receiving. Careful inspection will be conducted when receiving the goods according to detailed information listed including the names of the goods, categories and required quantities. In the traditional warehouse, inbound entry is usually written by the warehouse keepers. On the contrast, the entries will be recorded when the items come into the system via AutoID-based automatic scanning. Based on these real-time information, CW system can automatically assign appropriate cargo to suitable temporary buffer for further processing. The items that arrive without prior notices or do not meet the requirements will be sent back.
- (2) The step following receiving is put-away, in which step the items from the same batch will be broken up and put on the shelves of different cells. Firstly, the goods will be clustered pursuant to their properties such as categories, sizes, weight, functions, surface characteristics or even sales volume. The methods to cluster these products will be made referring to the clustering approach in cellular manufacturing field. However, it might be more complex in cellular warehouses since the items will be more diverse. Then the product families will be matched with the machines or workers to handle or store them. With the relationship, it can be determined which cell they will be assigned to. For example, the items of regular appearance such as the standardized boxes coming in large quantities will be assigned to the completed automatic cell, where the machines will handle these items readily. On the other hand, it is likely that there are not appropriate automation systems to deal with the items of anomalous shape or size. Therefore, such items will be assigned to the manual cell. There will be semi-automatic cells as well for several medium-volume cargo with not too urgent delivery requirements. The items will be transmitted to the corresponding cell by conveyors or smart AGVs. The materials will be put neatly on the shelves and bounded with the corresponding shelves. The information recording the operation on the item, the exact location of the item and its every movement will be recorded in the IoT device/tag and uploaded to the cloud.
- (3) The items will be kept as stocks before they are scheduled to deliver to the customers. Cycle counting on the status or changes of the items will be conducted. Given there are any deviation between the record in the cloud and the physical warehouse, the reasons will be figured out by specialized employees and the problem will be tackled according to the instruction received from the cloud. The missing parts, damaged, spoiled or the overdue goods will be replenished in due course. Every change including the dispose, replacement and addition will have a faithful account in the cloud. In the cellular warehouse, products of different categories, shapes, sizes and functions will be stored in different shelves or cells so that the system can locate the items easily. With the inherent priority scheduling algorithm, the system will check the products regularly at different frequencies for a higher efficiency with a lower cost. Important or special products will be counted more often, such as the items ordered by customers of higher priorities, the products stored in thermostats, the perishable goods, and the high-value goods.
- (4) The order can be placed by the various channels in Omni-channel retailing, including the website, mobile APP and the market. These orders will be integrated on the cloud and processed in a unified framework. The details of the orders will be released to the physical warehouse, including the name of the items ordered, the promised delivery time and the address of the end-customer. Accordingly, the employees or the machines can prepare the related order fulfillment operations. In the traditional pick-and-pass warehousing system, there will be a picking line that has multiple pickers and each picker will pick the items of an order located in the shelves. The order pickers will be guided by the light indicator quickly to the picking locations. The items will move along the entire picking line to arrive at the consolidation location. When one order is finished, the data of the next order will be sent to all modules in the zone. On contrast, in the cellular warehousing system, the picking

- process can be more flexible to save time dramatically. The items will be firstly picked from the shelves. Given some items do not need to be clustered with the other items in the picking zone, these items will be directly moved to the consolidation by the smart AGV and prepared for dispatching. The AGV will generate the shortest path from the location of the items and the destination, while there is no need for the items to go along the entire picking line. Assuming the items need to be combined with other items belonging to the same order, the AGV will also walk along the shortest path to collect all of them before going to the destination. In this way, the transportation time is saved to a large extent. What is more, multiple orders can be deal with at the same time, because the AGV can help cluster the items of the same order. Given the items of different orders will not pass the same picking line, they will not be mixed up. All these movements will be computed on the cyber layer.
- (5) The items picked from the shelves will be transmitted along the planned path to the consolidation. As mentioned, usually, in the traditional pick and pass system, the items are moved along the conveyor belt, so the items have to pass all the zones even if some do not need to be consolidated with the other items, leading to a waste of time. In the PI-enabled cellular warehousing system, smart AGVs will play a more important role. Before arriving at the goods will only go through some pre-determined cells where they will be operated on or aggregated with the other goods. In the consolidation cell, the goods are sorted and clustered again. To save the waiting time in the consolidation station, it is important to establish the appropriate intra-cell synchronization algorithms. In this way, different cells can operate on the items belonging to the same order simultaneously. When they arrive at the consolidation station within the same period, they can be aggregated quickly for the following packing and dispatching. The synchronization algorithm will include synchronized order release, order assignment, order scheduling and machine scheduling to support the combination and partition of the orders as well as the concurrent operations of orders. The smooth process will rely on the buffers and smart AGVs. The AGV will move the items to the consolidation along the optimized path and some buffers need to be set in each cell and the consolidation station to avoid the congestion. When some items arrive early, they will be assigned to the buffers to wait for the late-coming items of the same order. With appropriate synchronization algorithms and buffering control tactics, the deviation in the arriving time can be shortened as much as possible to save time and the space needed by buffers. The consolidation efficiency should be high enough so that the consolidation station will not become a deadlock of the warehouse, since the operation speed and the transit speed have been increased a lot in the PI-enabled cellular warehouse. With the support of synchronization, it is possible to achieve the concurrent or parallel cross-cell operation on multiple orders or multiple jobs with minimized throughput time.
 - (6) The goods will be packed and loaded to the vehicles at the dispatching bay. The cloud will inform the warehouse keeper or the machines of detailed shipping plan, including the assignment of the goods to the vehicles, the planned delivery schedule, the paths, the addresses of the customers and other specific requirements of the customers. The whole intelligent loading and dispatching process will be supported by PI. Each vehicle, item, and loading machine can be tracked and traced by the cloud. The cloud will guide the loading machine to automatically move the item to the corresponding vehicle. The outbound record will be uploaded to the cloud.
 - (7) It is noteworthy that cross docking is still allowed in a PI-enabled cellular warehouse. Given some items are ordered at once when they arrive at the warehouse, they will be directly moved to the dispatching location by the smart AGVs to save operation time and storage space.

3 The key elements in a PI-enabled cellular warehouse

To support the above processes, a general PI-enabled cellular warehouse is shown in Figure 2 with two layers: the physical warehouse layer and the cloud cyber decision layer.

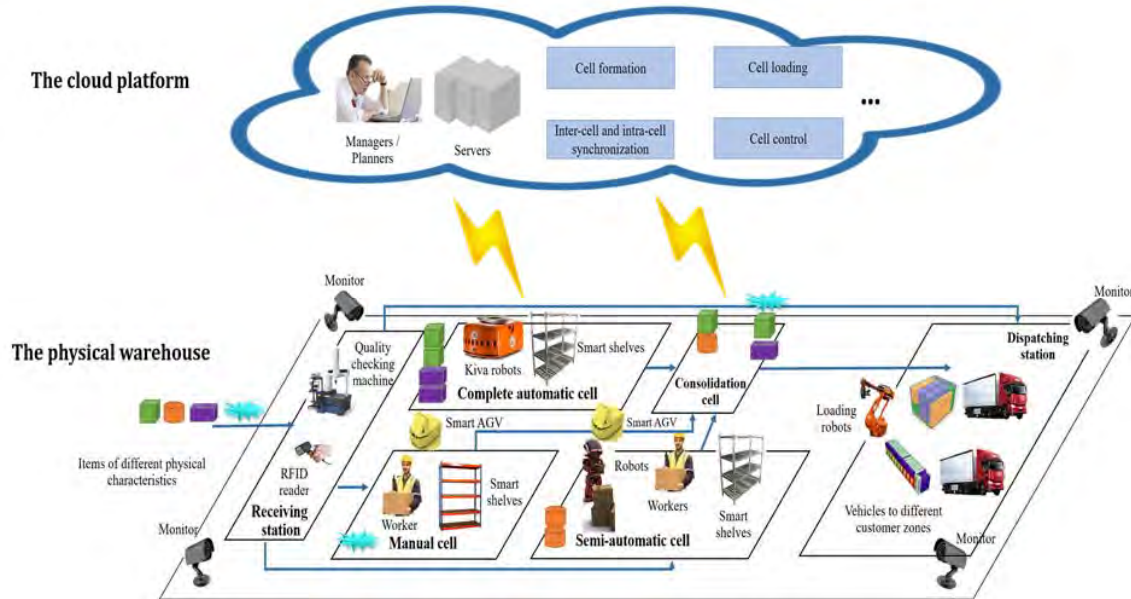

Figure 2: The key elements of a cellular warehouse

3.1 The physical warehouse layer

As illustrated in Figure 2, the physical warehouse consists of “smart” operators, facilities and materials, which are distributed in the receiving station, warehousing cells, consolidation cells and dispatching stations. Every item is “smart cago” enabled by IoT device/tag, recording and updating the corresponding information, such as the name, quantity, quality, location and logistics status. All men and machines within the warehouse are equipped with a transceiver to achieve interoperability with surrounding environment. They can upload the data to the cloud real-timely while receiving the instructions from the cloud. In addition to the transceivers, the monitors are spread all over the CW so that the managers or planners can keep watch on the process in the physical warehouse easily. The intercell and intracell movement of the materials are mostly completed by smart AGVs, since they can move more flexibly compared with conveyors. The path of the AGVs will be planned via the cloud in advance. The blue arrows in Figure 2 stand for the material flows among the cells. The detailed introduction to the elements within each cell is as follows:

(1) Receiving station: smart IoT devices will be implemented in the receiving station, so the tags of the inbound items will be read efficiently, which carries a lot of information of the items, which vary from one to another in terms of physical characteristics. The information will be uploaded to the cloud quickly. The smart devices including the quality checking machine will be installed in the receiving station as well. In case any bias is detected, the problem will be uploaded to the cloud and the items will be rejected.

(2) Warehousing cells: there are different cells within the warehouse to operate on and keep the inventory of various items. The exact numbers and sizes of the cells as well as the specific design of cells depend on the needs of the individual warehouse. Generally, there are three types of warehousing cells in the conceptual model of the cellular warehouse. The first one is the completely automatic cell. The items of regular shapes in large amounts will be deal with in this cell. High-end automation facilities are installed in this cell, such as the Kiva robots

of Amazon. These machines can complete the job with a high efficiency and a low error rate, compared with human beings. However, the major drawback of the automation facilities is that they are usually especially designed to handle some standardized products/boxes. Therefore, the second one is the manual cell that is more like the traditional warehouse. The items of very irregular appearance may not have corresponding automation machines. Given they do not have a high sales volume and come out not very often, it is not worthwhile cast high investment for the design, test and manufacturing of the automation machines to handle them. In this case, the workers will be assigned to deal with the goods. The third kind of cell is the semi-automatic cell, where the automation degree is lower than 100%. The machines and robots are not as advanced as those in the first cell, so the efficiency is relatively low. However, they are designed in a more general way so different goods can be handled within the same cell. The most innovative parts of the warehousing cells are reflected in three aspects: the smart operator, the smart facilities and the smart materials.

- **Smart operators:** In PI-enabled cellular warehousing system, every operator will be equipped with intelligent IoT devices, such as wearable sensors and scanners. They can scan the information and learning about the items easily while operating on the items. Each operator has a good command of multiple skills and is not fixed in one location. They can complete various operations on the item and offer a help to other operators when needed. All their operation data and the data collected by their sensors or scanners will be uploaded to the cloud and be accessible by others.
- **Smart facilities:** The major smart facilities in the PI-enabled cellular warehousing systems include smart trolleys, smart AGVs and smart robots. The trolleys are movable shelves. After the items are well received, the items will be put away on the smart trolleys. They will be bound with the corresponding trolleys and their data will be uploaded to the cloud, describing their name, location and condition. Each trolley has some joint components on their side with which they can be hooked with other trolleys. In this way, the storage facilities can be configured, assembled, expanded and disassembled with ease as needed. The smart AGV can pick some items from the trolleys and move them. Alternatively, the smart AGV can also drag the entire smart trolley to the destination. The basic process is as follows. When some items on the trolley or the entire trolley need to be picked or moved, the trolley will send a request to the cloud. The cloud will look for the most appropriate AGV to complete the job with a consideration of the capacity of the AGVs, their distance to the trolley, the obstacles on the way, the basic transportation needed, the energy to be consumed and the operation cost. The appropriate AGV will be assigned to pick the items or trolleys. This is called centralized decision. In some decentralized scenarios, the assignment and matching job may be completed by the AGV itself. The cloud will only serve as an information sharing platform in the process, and every AGV will receive the request from the trolley. Multiple AGVs will compete for the request on the basis of their own conditions. The trolleys will select the most appropriate AGV which will take the shortest time. Alternatively, other selection methods can be considered. For instance, the first AGV taking action of competing for the task will be assigned to pick the order. The third type of smart facilities is the smart robots. In addition to the robots in receiving station and dispatching bay, most robots are distributed in the warehousing cell. They moved around the warehouse to help in operation, movement, and storage. The smart robots will be equipped with some IoT devices, such as the intelligent tags and sensors, so that the real-time sensing on any status change can be achieved. The managers and supervisors can monitor and control the progress of the smart robots in real time via the cloud with the help of these IoT devices. The seamless communication and operation can be better guaranteed.
- **Smart materials:** Each item should have a smart tag, such as the RFID tag. On arrival in the system, the data of the item will be uploaded. During the entire process, the item will be tracked and traced.

(3) Consolidation cell: in this cell, the machines will consolidate the orders according to the instruction from the cloud. The orders to be sent to the customers in the close zones will be sorted and consolidated. Especially, some intelligent sorting systems have been established, such as the Sure Sort system, t-Sort system and Celluveyor.

- Sure Sort:** Sure Sort (OPEX Corporation, 2018) is an intelligent extendible sorting system (see Figure 3) for sorting small items, such as the nail polish, potato chip bags and water bottles. Sure Sort system is a smart automatic system designed by OPEX Corporation on the basis of mature iBOT delivery technology. The working mechanism is as follows. The Sure Sort will first scan the replenishment and wave or batch picked small items by reading their barcodes. The barcode reading can be completed from any angle regardless of the size, packaging or orientation of the items. The barcode data will be uploaded to the iBOT system and then to the warehousing management system (WMS). The WMS will send the assigned order locations to the Sure Sort in return. The items will be accurately delivered to the end location on a single pass accurately and easily. When the order is completed, the shipping container is transported to a packing station preparing for the shipment. Compared with the traditional sorting system, Sure Sort reduces the number of transfers and conveyors required to complete the sorting work so that the sorting efficiency and accuracy is improved dramatically. 2,400 items can be handled by a single pass per hour. What is more, it is highly scalable in size and throughput. The expansion modules can be added simply to adjust to the growth in demand. It is worth noting that the Sure Sort is mainly designed targeting as the small items, while it does not work well for handling the items in large sizes.



Figure 3: The Sure Sort system (OPEX Corporation, 2018)

- t-Sort:** t-Sort (Tompkins Associates, 2018) is a sorting, picking and consolidation system (see Figure 4) designed mainly for medium-sized items, such as containers of liquids, bags, boxes, mailers, apparel, footwear, general merchandise, single items and inner packs. It is established collaboratively by Tompkins International and lab Z. It is the first portable automated parcel sortation system in the world, which brings unmatched flexibility and throughput. The uniqueness of t-Sort system is that it uses completed independent robots without tracks. These robots are allowed to travel to any saturation independently along the pre-determined shortest path, just as the smart AGVs mentioned in the last section. Such robots can help greatly enhance the efficiency to maximize the operational capabilities of warehouses. In the system, the free-moving and independent robots are adopted to replace the traditional conveyors, sorters and tilt trays. The space utilization will be increased dramatically so that the required space is reduced. The robots can be modularly added without interrupting or stopping the operation of the system. By offering more flexibility,

the system will not face the risk of downtime of the entire system because of a single point of failure anywhere, because the elements are plug and play.



Figure 4: The t-Sort system (Tompkins, 2018)

- Celluveyor:** The Cellular Conveyor (Celluveyor) is a flexible conveying and positioning system (see Figure 6) that has distinctive advantages when dealing with items of large sizes and complicated shapes, such as mega boxes and some furniture. The Celluveyor is composed of small hexagonal modules, each of which is supported by omnidirectional wheels. These wheels are controlled by an electric motor via the controlling software, and each wheel can be turned into different directions independently. In this way, the wheels in the hexagonal modules can be combined to form a path of any shape that fits the needs. The items can be transported to the destination through the Celluveyor system automatically and the direction of the item can be changed by simple operations on the controlling software. With the innovative design of the wheels and the selective control methods, even large parcels can be moved along any path to any destination via the system easily. Several items can be moved simultaneously on the track, saving a lot of transportation time and the footprints of workers.

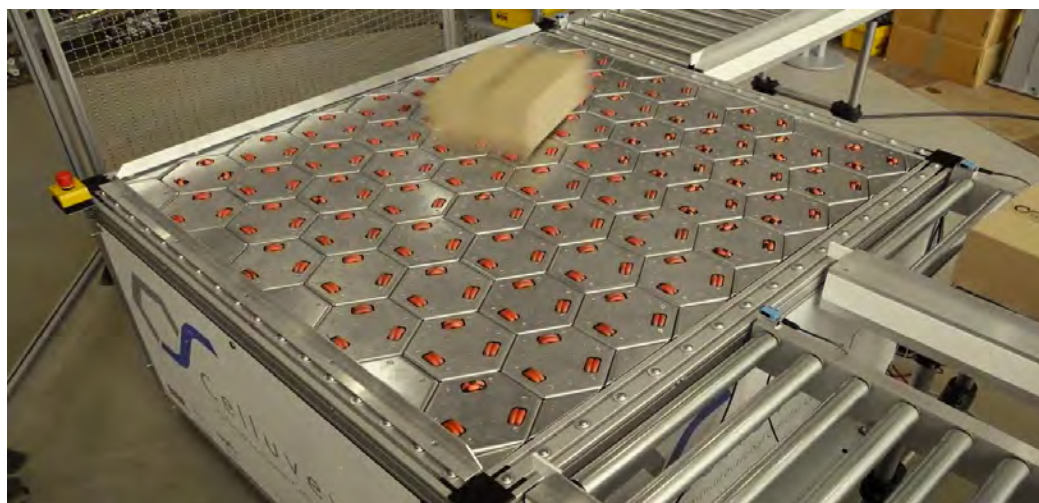

Figure 5: The Celluveyor system (Celluveyor, 2018)

As can be seen, many major logistics companies and labs all over the world are designing new warehousing systems to chasing for higher efficiency, accuracy, flexibility and space utilization rate as well as lower costs and risks, especially when the orders usually come in small batches and items vary from one to another. Some innovative technologies are now available to handle some types of items, such as Sure Sort or t-Sort. However, one sorting system or warehousing

system is usually designed for one category or several categories of goods, but they are not able to handle all types of items. Therefore, these systems should be allocated to different cells in the cellular warehouses, and one cell will handle a portion of all orders. There is a need of establishing a framework for formatting the cells and assigning the items to various cells, i.e. the cell formation methods.

(4) Dispatching bay: the loading robots will help handle the loading jobs to save the manpower to a great extent based on smart truck loading schedule. The items ordered by the customers in the adjacent customer cells will be assigned to a departing truck or trailer. The truck will not stay in the dispatching bay for a long time, because a high turnover rate should be guaranteed. Given there are no containers ready, the trucks should not queue in line in the dispatching station to avoid a deadlock. Though in the picture, the dispatching bay and the receiving station are on the opposite side of the warehouse. In reality, they might be located near each other, depending on the design of the warehouse.

3.2 The cloud cyber decision layer

The cloud cyber decision layer mainly focus on the design, planning and optimization-related issues, including cell formation, cell loading with staff/machine assignment, inter-cell or intra-cell synchronization and cell control tactics.

(1) Cell formation: cell formation is the first stage in cellular warehousing design. There have been many mature cell formation methods in the field of cellular manufacturing, including mathematical programming, the visual inspection based method, similarity coefficient technology, the array based method, the graph theory, classification and coding techniques, the neural network, knowledge based system, fuzzy clustering, and simulation of the heuristics system. They are designed to increase the efficiency, throughput, machine utilization rate or reduce the cost subject to the constrains of the machine capacity, technology limitations, cell numbers, and machine availabilities. They might be taken as references when designing the cell formation models in cellular warehousing. For example, Tsai et al. (2006) came up with a multi-functional mathematical programming model to optimize the cell formation in cellular manufacturing, which is induced from conventional classic models (Adil et al., 1996; Dahel et al., 1993; Vakharia et al., 1993). The model can help achieve different objectives such as minimizing the number of intercellular transfers or minimizing the total number of EEs and voids, while constrained by corresponding relationship between the parts and the machines, the number of a certain type of machine in a cell and the processing sequence. This model can be taken as reference when designing the cell formation in cellular warehousing. In CW, there are also the intercellular transfers of items, which should be reduced as many as possible to save the cost. The objective will be constrained by similar conditions as well. Such model can be referred to when establishing cell formation model in the field of cellular warehousing, because they share similar objectives and constrains. However, several differences exist as well. For example, along with the emergence of smart AGVs which can plan their routes and move freely without strictly restricted paths, the distance from one location to another location is not determined and there will be many more pairs of locations. This will lead to the difficult to compute the distance between two points. For another example, the matching relationship between the part and machines are known in the mathematical model of manufacturing cellular formation problem, while in omni-channel retailing warehouses, large volumes and varieties of e-commerce goods complicate the model formulation. Therefore, the matching relationship has to be found with great efforts.

(2) Cell loading with staff/machine (re)assignment: Cell loading refers to determining which cell among all feasible cells the items should be assigned to and in what kind of order (Suer et al., 1999), which is especially crucial when there are multiple cells within a warehouse. By designing appropriate cell loading process, the work-in-process and lateness can be minimized

while the utilization rate of the cells can be maximized. It will also lead to a better balance of the load among the cells. Several tasks will be required, which are product selection, cell selection and order confirmation for assigning the items to cells. In the cellular warehousing, product priority will be considered in the most cases, i.e. the item will be chosen first and then the search shifts to find the cells for the item. There are classic rules for cell loading in cellular manufacturing giving priorities to products or cells which might be referred, including earliest due date, number of feasible cells, number of cells required and cell loading rules.

(3) Inter-cell or intra-cell synchronization: Synchronization of the inter-cell and intra-cell operations can help increase the efficiency and reduce the cost. With appropriate synchronization mechanism, the items finished in one cell do not need to stay a long time in the consolidation state for the other items belonging to the same order. Given they can arrive within the same time window, they can be packed quickly for dispatching. To achieve the synchronization, different cells should have the identical operation time on the items of the same order and the machines should be synchronized with the operators. This can be achieved with the full use of the cyber optimal decisions in cloud. The operation data will be uploaded to the cloud in real time, so that the pace of the set up or operation of one machine/robot can be adjusted according to the status of another one in the same cell or another cell.

(4) Cell control: The overall cell control includes the control of the stock, indoor transport, operation, inspection and packing within the cells. Especially, the control over the workstation includes the control of machine setup, the material handling and the buffers. Cell control is vital since it can facilitate minimizing the exposure risk to single point failure, improving the total warehousing performance, providing responsive decision support tools and saving operation costs (Huang et al., 1992). To offer the potential for improved cell control, both software and hardware supports are needed. The software should be used to facilitate the system (re)configuration and easy-to-customize for specific warehousing scenarios. The hardware should facilitate expansion and modification for a higher degree of flexibility.

4 Case Study

Through some visits to the major ecommerce logistics companies and the collaboration work with them, our research team has observed that some companies have set about upgrading their warehouses, which might be considered as an early version of PI-enabled cellular warehousing system. The Figure 6 is the warehouse plan of Alibaba Group (left) and COSCO (right)

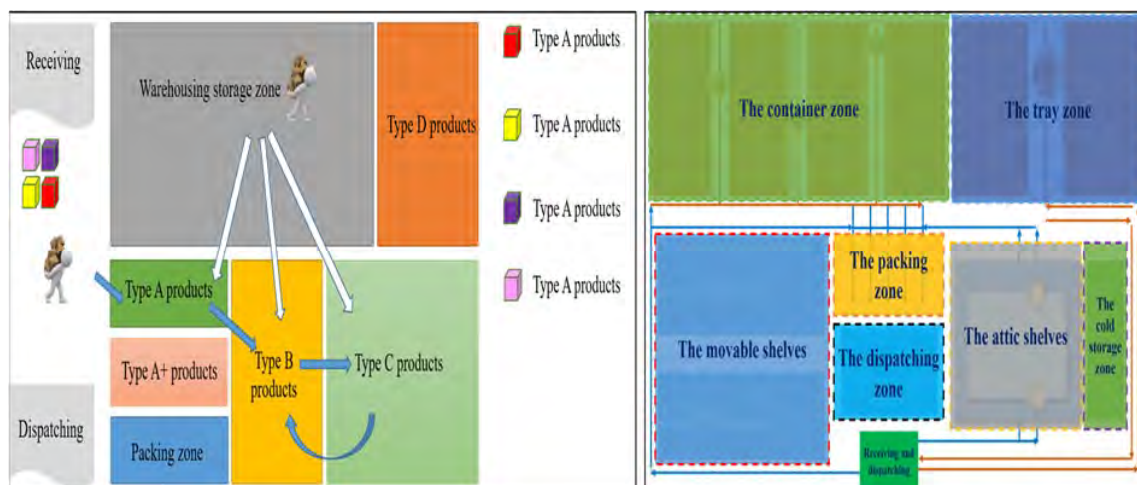

Figure 6: The linked storage and picking mode of the warehouse of Alibaba Group (Huanqiu tech, 2017) (left) and the warehousing plan of COSCO (HKU-Ziri Lab, 2018) (right)

4.1 Alibaba

Alibaba has upgraded their warehouses with automation as well and is attempting to divide its warehouse into different zones for keeping different products (see Figure 6 left). It is planning to roughly partition its warehousing system to three major cells this year.

Currently, Alibaba already has relatively the mature ordering management system (OMS), warehousing management system (WMS) and transportation management system (TMS). In the OMS, one single tag attached on the item contain all the necessary data, including its name, category and locations. Billions of data can be well handled with the powerful computation system and the item location will be identified automatically. In the WMS, the items ordered will be replenished within the required time window automatically. The intelligent robots adopted by Alibaba can lift heavy items, queue, and move away from the obstacles. The TMS is able to track and trace the logistics through the entire process in real time.

However, with the booming development of omni-channel retailing and ecommerce, the varieties and quantities of items will increase dramatically. It is still difficult to cater to the market demand with only automatic warehouses. Therefore, Alibaba Group is considering establishing a preliminary cellular warehouse this year. It is to build a completely automatic warehousing cell with cutting-edge technologies such as Kiva robots, a semi-automatic warehousing cell and another manual warehousing cell with more manpower. Different items will be assigned to different warehousing cell according to the physical characteristics of the items, the popularity or sales condition of the items, as well as the advantages and the capacities of the warehousing cell. Whereas, this is just a relatively rough design now. Because it is urgent for Alibaba to set about building this warehousing system to catch up with the development of the market, Alibaba has not found a method to compute the quantity and confirm the design of the cells with the information of items.

4.2 JD.com

JD is another successful group, of which the warehouse is the rudiment of PI-enabled cellular warehouse. The warehousing center of JD.com is composed of four operating systems: receiving, storage, picking and packing system.

Each operational stage of its warehouse is supported by innovative systems, advanced data processing technologies and algorithms. For example, the receiving station of JD.com is equipped with intelligent robots for unpacking the packages and identifying the items. Then, all inbound and inspected items are put-away in storage area. AGVs are used in internal movements that make full advantage of the QR code on the ground to locate and navigate itself. They can even avoid the obstacles automatically and optimize their paths from the departure point to the destination to save time and distance. In the sorting system, intelligent robots are responsible for the moving items of different sizes or shapes. Advanced visual technologies are applied to act as “eyes” of the machines to achieve the interaction and connection of the robots or machines with the surrounding environment.

The data processing technologies developed by JD.com play an important role in the warehousing process. By making use of the real-time monitoring and simulation technologies, the system can collect the data reflecting the performance of every machine in real time. Given any unusual data is detected, the system can diagnose the error and find the counter-measures from the system to facilitate self-configuration, self-maintenance and self-control.

Deliciated algorithms are adopted by JD.com to improve the warehousing operation efficiency. With these algorithms, the system can automatically suggest the most appropriate storage locations with regard with the sales volume and the physical characteristics of these items. In the dispatching process, the inherent algorithms will compute the locations of the items which

is the most appropriate to be picked from many identical items. The scheduling algorithm will suggest the corresponding AGV to move the items, which will incur the lease moving cost in terms of time and distance.

It can be seen JD.com has established different systems targeting at handling products of different shapes, sizes and sales volume, although it has not started to take the further step to locate them into different cells. What is more, the basic algorithms and automatic machines to facilitate the implementation of cellular warehousing system.

4.3 COSCO

COSCO aims at designing a highly flexible ecommerce warehousing system (see Figure 6 right), which has a stable performance in terms of inventory and turnover rate under the fluctuated demands.

To achieve this objective, COSCO has come up with several innovative designs. For example, there are two major types of conveyors in their warehouse. The conveyors of the first type is responsible for transmitting items only and they are equipped with many idler wheels so that they are movable and can be freely spliced. The second type can help in sorting while transporting the items, so they are fixed in the most cases.

Similarly, their shelves are movable as well so that they can be configured as needed. Different movable shelves are selected for keeping goods of different characteristics in terms of size, categories, weights and special requirements on the environment. In other words, products of different characteristics will be sorted by their light sorting system first and then go to different shelves.

Then, their operating tables are extensible so that more working stations can be added in the peak season and vice versa. On the operating tables, most of the machines including computers, weighting machines, packaging machines and monitors are customized according to their needs. These operating tables can be moved freely to combine with other operating tables according to the planned operation process.

In addition, their thermostatic chambers are designed referring to the container concept so that they can be moved with ease. Last but not least, they adopt the mixed-flow turnaround system to integrate the merits of different systems leading to a much higher efficiency

With these innovative designs, COSCO increases their flexibility to a great extent. In the slack season, they will reduce the scale of storage zone and operation zone. The number of conveyors and operators will be cut down. The automation zone is closed to save cost. On the contrast, in the peak season, the storage zone and operation zone will be enlarged to cater to the increasing needs. Both number of conveyors and operators will be increased. The automation zone will be activated so as to improve the operation efficiency and accuracy.

As can be seen, they have partition their warehouse into several zones and the flexibility is high. However, there is still room for improvement. For example, the adjustment from peak season to the slack season may leave some machines idling. It seems that they do not have a mature plan to deal with the excel capacities to reduce the opportunity cost. Therefore, a wiser plan of establishing cell warehousing systems is needed to further enhance efficiency and flexibility while reducing the waste of resources.

5 Discussion and conclusion

The era of omni-channel retailing is just around the corner, which will bring valuable opportunities and critical challenges to the logistics, especially the warehousing area. Considering the orders will come from various ordering channels any time in small batches and

large varieties, the traditional manual warehouses or automatic warehouses are not capable enough to cater to these complicated order fulfillment scenarios, not to mention the increasing tight delivery due date. By referring to the cellular manufacturing concept which improves the operation efficiency greatly, this paper comes up with the paradigm of cellular warehousing. With the emerging and innovative technologies, it is possible to apply this concept in the near future. This paper suggests the general process and basic elements to support the operation of a typical cellular warehouse. The practices of three leading Chinese ecommerce logistics companies are briefly discussed, which verify the necessity of establishing a new paradigm of warehousing system and can be considered as a very early form of PI-enabled cellular warehouses. The avenues of the future research on the implementation of cellular warehousing concepts are open, because there are still many specific research, technical and development questions with regard to cellular warehousing.

Our future work on cellular warehousing will mainly consists of three areas, which are the framework of cellular warehousing, the cellular formation models and the impact of uncertainties on cellular warehousing.

First, the framework of cellular warehousing will include some major problems, such as the competition and collaboration game theoretical relationship among the cells, the dynamic equilibrium of workers/machines/items, the impact of advanced technologies such as the big data, the exact constraints or conditions to apply the cell concepts into a warehouse for major logistics companies and small or medium sized logistics players, and the technologies required to support CW implementation.

Second, the cell formation method will be suggested, which is the first stage in cellular warehousing design. There are some research questions with regard to cell formation.

- What is the objective of cellular formation?
- Which method among many mature manufacturing cellular formation methods is more applicable to CF problems in cellular warehousing?
- What is the impact of key parameters on cellular warehousing formation?
- What is the impact on the stakeholders of improved cellular formation?

Third, the uncertainties from many sources will be discussed, such as the fluctuating demands and the composition of an order structure, leading to a changing requirements on the capacity and efficiency of the warehouses. The priority of customers is another source of uncertainty, requiring a reasonable and practical algorithm to sequence the various orders to optimize its service level. To further explore the impacts of these uncertainties on the performance of cellular warehousing, some classic methods for cellular manufacturing such as modeling and simulation might be applied to CW to simulate the real cases.

References

- Adil, G. K., Rajamani, D., & Strong, D. (1996): Cell formation considering alternate routings. *International Journal of Production Research*, v34, no5, 1361-1380.
- Bhasin, K., & Clark, P. (2016): How Amazon triggered a robot arms race. *Bloomberg Businessweek*.
- Celluveyor. (2018): The Celluveyor – material handling 4.0. <http://www.celluveyor.com/en/2018/04/30>.
- Celluveyor. (2018): Celluveyor – success story with DHL. <https://www.youtube.com/watch?v=GVrpMd8AYG8>. 2018/04/30.
- Cummins, S., Peltier, J. W., & Dixon, A. (2016): Omni-channel research framework in the context of personal selling and sales management: A review and research extensions. *Journal of Research in Interactive Marketing*, v10, no1, 2-16.

- Dahel, N. E., & Smith, S. B. (1993): Designing flexibility into cellular manufacturing systems. *International Journal of Production Research*, v31, no4, 933-945.
- Fei, L. I. (2013): Connation, Cause and Countermeasures of Omni Channel Retailing—Further Discussion on How to Meet China Multi Channel Retailing Revolution Storm. *Journal of Beijing Technology and Business University (Social Science)*, v2, no002:
- Golmohammadi, A., & Ghodsi, R. (2009): Applying an integer Electromagnetism-like algorithm to solve the cellular manufacturing scheduling problem with an integrated approach. In *Computers & Industrial Engineering*, 2009. CIE 2009. International Conference on IEEE, 34-39.
- Gonçalves, J. F., & Resende, M. G. (2004): An evolutionary algorithm for manufacturing cell formation. *Computers & industrial engineering*, v47, no2-3, 247-273.
- HKU-ZIRI laboratory for Physical Internet. (2018). The flexible intelligent ecommerce warehousing system of Casco.
- Huang, G. Q., Chen, M. Z., & Pan, J. (2015). Robotics in ecommerce logistics. *HKIE Transactions*, 22(2), 68-77.
- Huang, H. P., & Chang, P. C. (1992): Specification, modelling and control of a flexible manufacturing cell. *The International Journal Of Production Research*, v30, no11, 2515-2543.
- Huanqiu Tech. (2017): The intelligent warehousing system of Suning. <http://tech.huanqiu.com/news/2017-05/10699275.html>. 2018/04/30.
- Mahdavi, I., Paydar, M. M., Solimanpur, M., & Heidarzade, A. (2009): Genetic algorithm approach for solving a cell formation problem in cellular manufacturing. *Expert Systems with Applications*, v36, no3, 6598-6604.
- OPEX Corporation (2018): Sure sort™ is smart, streamlined, scalable order sortation. <https://www.opex.com/material-handling/sure-sort>. 2018/04/26.
- OPEX Corporation (2018): Sure Sort™. <https://www.youtube.com/watch?v=qSIKliDhPuw&t=1s>, 2018/04/30.
- Picot Coupey, K., Huré, E., & Piveteau, L. (2016): Channel design to enrich customers' shopping experiences: Synchronizing clicks with bricks in an omni-channel perspective—the Direct Optic case. *International Journal of Retail & Distribution Management*, v44, no3, 336-368.
- Piotrowicz, W., & Cuthbertson, R. (2014): Introduction to the special issue information technology in retail: Toward omnichannel retailing. *International Journal of Electronic Commerce*, v18, no4, 5-16.
- Shafer, Scott M. and Ernst, Ricardo (1993): Applying Group Technology Principles to Warehousing Operations. *International Journal of Purchasing and Materials Management*, v29, no1, 38–42.
- Salum, L. (2000): The cellular manufacturing layout problem. *International Journal of Production Research*, v38, no5, 1053-1069.
- Selim, H. M., Askin, R. G., & Vakharia, A. J. (1998): Cell formation in group technology: review, evaluation and directions for future research. *Computers & Industrial Engineering*, v34, no1, 3-20.
- Solimanpur, M., Vrat, P., & Shankar, R. (2004): Ant colony optimization algorithm to the inter-cell layout problem in cellular manufacturing. *European Journal of Operational Research*, v157, no3, 592-606.
- Suer, G. A., Saiz, M., & Gonzalez, W. (1999): Evaluation of manufacturing cell loading rules for independent cells. *International Journal of Production Research*, v37, no15, 3445-3468.
- Tavakkoli-Moghaddam, R., Javadian, N., Khorrami, A., & Gholipour-Kanani, Y. (2010): Design of a scatter search method for a novel multi-criteria group scheduling problem in a cellular manufacturing system. *Expert Systems with Applications*, v37, no3, 2661-2669.
- Tavakkoli-Moghaddam, R., Javadian, N., Javadi, B., & Safaei, N. (2007): Design of a facility layout problem in cellular manufacturing systems with stochastic demands. *Applied Mathematics and Computation*, v184, no2, 721-728.

- Tompkins (2018): Tompkins robotics. <https://www.tompkinsinc.com/Services/Tompkins-Robotics>, 2018/04/26.
- Tsai, C. C., & Lee, C. Y. (2006): Optimization of manufacturing cell formation with a multi-functional mathematical programming model. *The International Journal of Advanced Manufacturing Technology*, v30, no3-4, 309-318.
- Vakharia, A. J., & Kaku, B. K. (1993): Redesigning a cellular manufacturing system to handle long-term demand changes: a methodology and investigation. *Decision Sciences*, v24, no5, 909-930.
- Verhoef, P. C., Kannan, P. K., & Inman, J. J. (2015): From multi-channel retailing to omni-channel retailing: introduction to the special issue on multi-channel retailing. *Journal of retailing*, v91, no2, 174-181.
- Xinhua net. (2017): Jingdong intelligent logistics is applied in large scale and its Nine Asia No. 1 are fully ready for Double 11. http://www.xinhuanet.com/tech/2017-09/25/c_1121721382.htm, 2018/04/26.

Inventory Control Models towards Physical Internet: Lateral Transshipment Policy Determination by Simulation

Banu Y. Ekren, Anil Akpunar, and Gizem Sağol
Yaşar University, Department of Industrial Engineering, Izmir, Turkey
Corresponding author: banu.ekren@yasar.edu.tr

Abstract: *Inventory control policy is crucial in a supply chain management, since it affects the performance of whole supply chain significantly. Recent advances has changed the order profile towards more product variety with less volume and decreased response time (e.g. same day delivery, etc.). This issue has created more variability in orders throughout the supply chain. Hence, management of inventory became a critical subject in a supply chain to alter this variability and increase the performance of the supply chain. This paper investigates an (s, S) inventory control model using the benefits of the Physical Internet that provides lateral transshipment between the intermediate hub locations. As a result of this study, it is observed that the performance of a lateral transshipment policy strongly depends on the studied network design and its parameter values as well as how the transshipment policies are pre-defined.*

Keywords: *(s, S) inventory policy, lateral transshipment, inventory control, physical internet.*

1 Introduction

Inventory control policy in a supply chain is critical, since the performance of whole supply chain is significantly affected from these policies. Due to recent increase in e-commerce, order profile has changed towards more product variety with less volume and decreased response time (e.g. same day delivery, etc.). This issue has created more variability in orders throughout the supply chain. Hence, management of inventory became a critical subject in a supply chain to alter this variability and increase the performance of the supply chain. It is declared that 40% of the total logistics cost belongs to the inventory costs in fast moving consumer goods supply chain (Cachon and Terwiesch, 2006). Hence, over the past few decades, numerous studies have dealt with inventory problems, e.g., studying optimization models (Waller et al., 2008; Bushuev et al., 2015) or testing new policies and practices such as lateral transshipment (Paterson et al., 2011; Pan et al., 2015; Yang et al., 2017a) and inventory routing problems (Bertazzi and Speranza, 2012).

By the recent technological development, realization of horizontal integration throughout the supply chain is possible. Hence, the management as well as the inventory control policy of a supply chain can be performed more efficiently. In a traditional supply chain, each firm can define its own network in which the warehouses (storage points) as well as replenishment schemes are fixed and dedicated, resulting in the current predetermined hierarchical multi-echelon inventory systems. However, in an innovative supply chain model, the system is more open, real time visible, flexible, and horizontally collaborative. Namely, an innovative supply chain network is a Physical Internet (PI) philosophy oriented network in which the distribution and storage system is transformed into a common, open, interconnected logistics network of PI hubs shared by numerous companies. PI is a mutually shared network, allowing users to keep stocks in any node in the network, also providing open multi-sourcing options for orders with on-demand warehousing services.

In this study, our aim is to approach an inventory management problem by considering that the supply chain works under the PI philosophy and to compare the proposed control policies under this assumption. Specifically, we aim to develop Physical Internet-based Inventory Control Models (PIICM) in a two-echelon supply chain network whose representation is given by Figure 1.

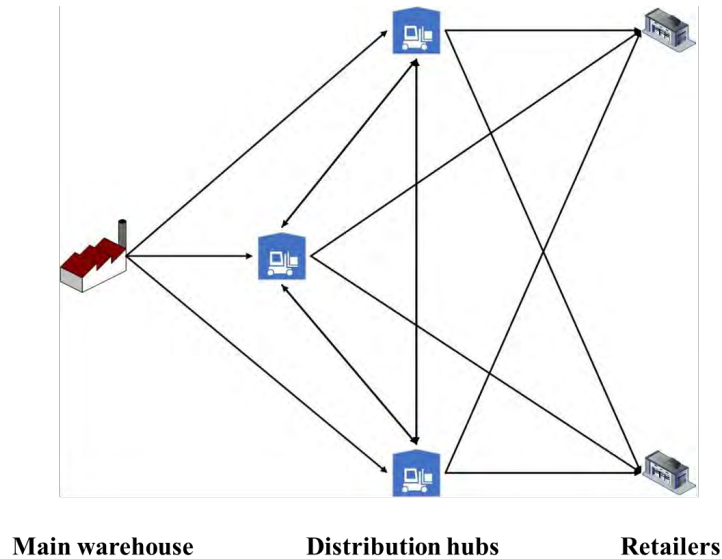

Figure 1: Two-Echelon Supply Chain Network

We develop simulation models for the studied network to find out the best control policy by comparing several lateral transshipment scenarios. We study two lateral transshipment policies (reactive or proactive) between distribution hubs and we optimize the (s, S) levels of the distribution hubs by OptQuest in ARENA 14.0 commercial simulation software. As a result, we compare the scenario results based on their total costs optimized in the simulation software, ARENA 14.0.

The remainder of the paper is organized as follows. We discuss the related studies about lateral transshipment and Physical Internet in literature review in Section 2. In Section 3, we present the two-echelon supply chain problem that we integrate the inventory control model with the Physical Internet transshipment policies. Section 4 aims to provide the simulation models with assumptions of the problem. Then, in Section 5, we summarize the results obtained from the simulation models for different replenishment policies. In Section 6, we conclude the paper by discussion of the findings from the models and possible research directions for future studies.

2 Literature Review

Inventory control models have been excessively studied in literature from various perspectives for decades. Therefore, we only include the related literature on this work which can be classified into three main categories: (i) (s, S) inventory control policies, (ii) Lateral transshipments in supply chain network, and (iii) Physical Internet based interconnected logistic activities in inventory control. The focus of our study is in the intersection of these three categories to find the best policy from different options. Note that, our aim is not to give a complete literature on the subject, but to provide an overview to follow our motivation for the paper.

The history of the (s, S) inventory control policies goes back to 1950s. Arrow et al. (1951) derived a simple model to determine the best maximum stock and the best reordering point as a function of demand distribution with a setup and stock out costs under immediate replenishment assumption. Freeman (1957) studied (s, S) inventory policy with the inclusion of variable delivery time to derive the order size and the reordering point from an analytical perspective. Since then, lots of different variants of (s, S) policies are analyzed and a considerable research is accumulated (i.e., Axsäter, 2015; Bashyam and Fu, 1998; Sethi and Cheng, 1997; Silver et al., 1998) because of its simple and efficient applications.

Lateral transshipment refers the inventory movement between the same echelon locations within a supply chain network, redirecting an incoming demand or redistributing the stock among the pooling members. It is beneficial for supply chain since it helps in increasing the performance of the multi-echelon inventory systems in terms of both cost and customer satisfaction (such as, Axsäter, 2003a; Axsäter, 2003b; Lee, 1987; Olsson, 2010). Generally, the studies focus on the decision of how the lateral transshipment will take place between the locations (i.e., Axsäter, 2003b; Çapar et al., 2011; Tiacci and Saetta, 2011). For instance, Axsäter (2003b) analyzes a single-echelon inventory system, which includes a number of parallel local warehouses with compound Poisson demand, and his decision rule is evaluated in a simulation study, and his results support that the rule performs quite good. Çapar et al. (2011) present another decision rule to coordinate the inventory and transportation in a two-stage supply chain through alternative supply sources, and they provide that their proposed decision rule outperforms the other alternative policies on the average. Tiacci and Saetta (2011) introduce a heuristic for balancing the inventory levels of different locations using lateral transshipment; as a result, they show that their heuristic for deciding on transshipment policy to minimize overall expected costs is effective on different scenarios. A recent review (Paterson et al., 2011) on inventory models with lateral transshipments provides a detailed analysis of the articles in literature, the interested reader can refer to this review article for further information.

The Physical Internet (PI) is a recent approach compared to the former subjects, yet it is a promising area for increasing the overall performance of the supply chain network. It is defined as an open, interconnected logistics systems based on the communication of all the components through interfaces and protocols (Montreuil, 2011). It is seen as a *groundbreaking* approach since it tries to avoid the inefficiencies in the classical supply chain models by introducing a global and interconnected logistics system (Sarraj et al., 2014). In order to understand and define the PI-enabled logistic activities, first of all, conceptual research is initiated (Pan et al., 2017; Ballot et al., 2010; Montreuil, 2011; Sarraj et al., 2014). Then, Pan et al. (2017) list the remaining categories for the contributions to PI as follows: assessment research, solution design research and validation research. The paper of Pan et al. (2015) which motivates our study can be classified under assessment research as introducing different perspectives of inventory control models using simulation under the PI logistics network. Moreover, Yang et al. (2017a, 2017b) study the effect of PI philosophy for different inventory models. Specifically, Yang et al. (2017a) show that PI-enabled inventory models can reduce the total logistics costs while satisfying the customer at the same or better level. Then, they (2017b) provide a novel approach to build a resilient supply network so that the performance increases when there are stochastic disruptions in the supply under uncertain demand. Hence, there are quite different opportunities to analyze the effects of PI-enabled logistics network on the decisions of supply chain management.

Consequently, our aim is to increase the knowledge on the assessment of the PI-enabled supply chain management by studying different transshipment policies on a two-echelon supply chain network. Next chapters introduce the problem, the designed network we analyze and our results.

3 Problem Definition

Inventory control is an important subject in supply chain management because it affects the whole supply chain performance significantly. The main task of inventory control is to satisfy customer demand while reducing the related costs: holding, transportation, ordering, backorder, etc. Hence, in an inventory control problem, it is crucial to develop appropriate control models by considering two critical issues: when and in what quantity to order. Besides these critical issues, by the development of Physical Internet (PI) and real time visibility of a whole supply network, a good inventory control problem should also consider utilizing the best lateral transshipment policy in the network (Axsäter, 2003a; Axsäter, 2003b; Olsson, 2010; Pan et al., 2015; Paterson et al., 2011; Tiacci and Saetta, 2011). Lateral transshipment helps to improve the supply chain network performance, especially when the backorder cost is high and lead times are long from distribution depots. Two types of transshipments are often addressed based on the timing of the transshipments: (1) reactive transshipments in response to an existing stock out (Krishnan and Rao, 1965; Robinson, 1990; Olsson, 2010); (2) proactive transshipments to prevent the future stock out (Gross, 1963; Diks and De Kok, 1996; Diks and de Kok, 1998; Tagaras and Vlachos, 2002).

In this paper, we study both reactive and proactive transshipment policies in a two-echelon supply chain network. We also study the combination of these both transshipment policies, which is the hybrid lateral transshipment policy. In the reactive policy, it is considered that transshipments may take place between distribution hubs when the current inventory level of a hub decreases to a level lower than its safety stock level. In the proactive policy, we consider that when the inventory level of a hub reaches to a lower level of a coefficient of its safety stock (SS_{Hj}) level, then lateral transshipments may take place between hubs based on the pre-defined rule explained in Section 4.1.2. In the hybrid policy, combination of the two policies are involved in the network. The details of the policies on the studied lateral transshipments are explained in Section 4.1.

4 Simulation Model

As mentioned previously, we study a two-echelon supply network to find out the best transshipment policy in which mainly two network designs are considered based on capacity of hubs and transportation cost parameter values. The first scenario is presented in Figure 2 along with the utilized parameter values. According to this scenario, there are two retailers and three distribution hubs, which can place orders to a main warehouse (MW) with infinite capacity. This network is simulated in ARENA 14.0 commercial simulation software with the assumptions summarized in Section 4.1. We seek the best lateral transshipment policy on the given two network designs by minimizing the simulation run total cost under pre-defined fill rate constraint (i.e. 95%).

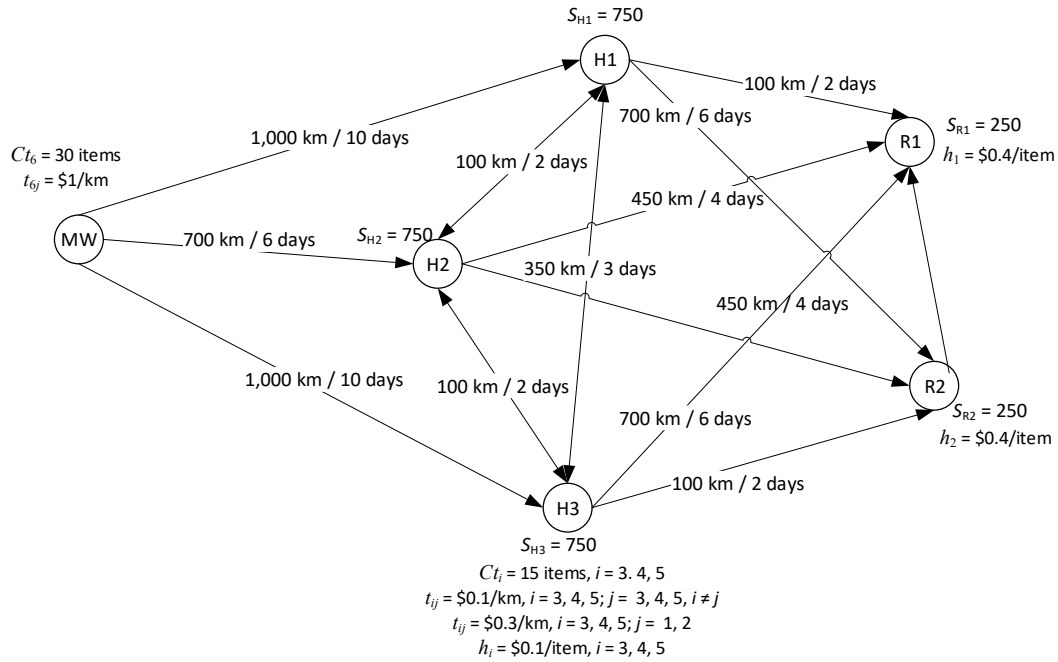

Figure 2: The Studied Two-Echelon Supply Network with the Used Parameter Values for Design 1

As seen from Figure 2, hubs have two-way item flow meaning that it is allowed to send items to a hub from any hub. The distances and lead times are shown on the arcs. Unit holding cost per item, travel cost per km., truck capacities as well as facility capacities are also given in that figure. Note that, Figure 2 belongs to the first studied design scenario in the network. We seek the best lateral transshipment policy on two different network designs. In Design 1, while the capacity of hubs is tight: $S_{H1} = S_{H2} = S_{H3} = 750$; in the second design, Design 2, the capacity of hubs is larger: $S_{H1} = S_{H3} = 1,000$ and $S_{H2} = 1,200$. In addition, in Design 1 the unit travel cost from hubs to retailers is $\$0.3/\text{km}$. and in Design 2, this cost is $\$1/\text{km}$. The notations that are used in the study are summarized below:

- SS_{Ri} : safety stock level of retailers, $i = \{1, 2\}$
- SS_{Hj} : safety stock level of hubs, $j = \{1, 2, 3\}$
- S_{Ri} : up-to level of retailers, $i = \{1, 2\}$
- S_{Hj} : up-to level of hubs, $j = \{1, 2, 3\}$
- α : coefficient for calculating share amount of items in hubs in reactive policy
- β_1 : inventory level check coefficient for proactive policy
- β_2 : coefficient for calculating share amount of items in hubs in reactive policy
- I_{it} : inventory level of retailer $i = \{1, 2\}$ or hub $i = \{3, 4, 5\}$ at the end of day t
- D_{it} : demand amount arriving at retailer i , at the beginning of day t , $i = \{1, 2\}$
- TC : total cost
- h_i : holding cost per item at retailer $i = \{1, 2\}$ or hub $i = \{3, 4, 5\}$
- Ct_i : truck capacity in hubs $i = \{3, 4, 5\}$ or main warehouse $i = \{6\}$
- t_{ij} : transportation cost from MW, $i = \{6\}$ or transshipment cost from hubs $i = \{3, 4, 5\}$ to any location in the network
- d_{ij} : distance (km.) from location i to location j , $i, j = \{1, 2\}$ for retailers; $i, j = \{3, 4, 5\}$ for hubs, and $i, j = \{6\}$ for MW
- Q_{it} : order amount of retailer i , $i = \{1, 2\}$ or hub $i = \{3, 4, 5\}$ at the end of day t
- q_{ji} : amount of transshipment from hub j to hub i where $j \neq i$
- b_i : backorder amount at day t at retailer i , $i = \{1, 2\}$
- tp : review period (i.e., days) for proactive lateral transshipment

The flowchart of the simulation model along with the transshipment policies is given by Figure 3. In the models daily demands arrive at the retailers with a stochastic distribution at the beginning of each day. Then, these demands are satisfied at the retailers by their current inventories. If backorder happens, retailers order items from the hubs based on the closest distance sequence until up-to level (S_{Ri}) plus backorder amount is met. If no backorder takes place, however $I_{it} \leq SS_{Ri}$, then, retailer i places an order as $S_{Ri} - I_{it}$ amount. The retailers order the items from hubs starting from the closest location. For instance, R1 checks H1, H2 and H3 in sequence, while R2 checks H3, H2 and H1, respectively. The details of the transshipment policies are summarized in Section 4.1.

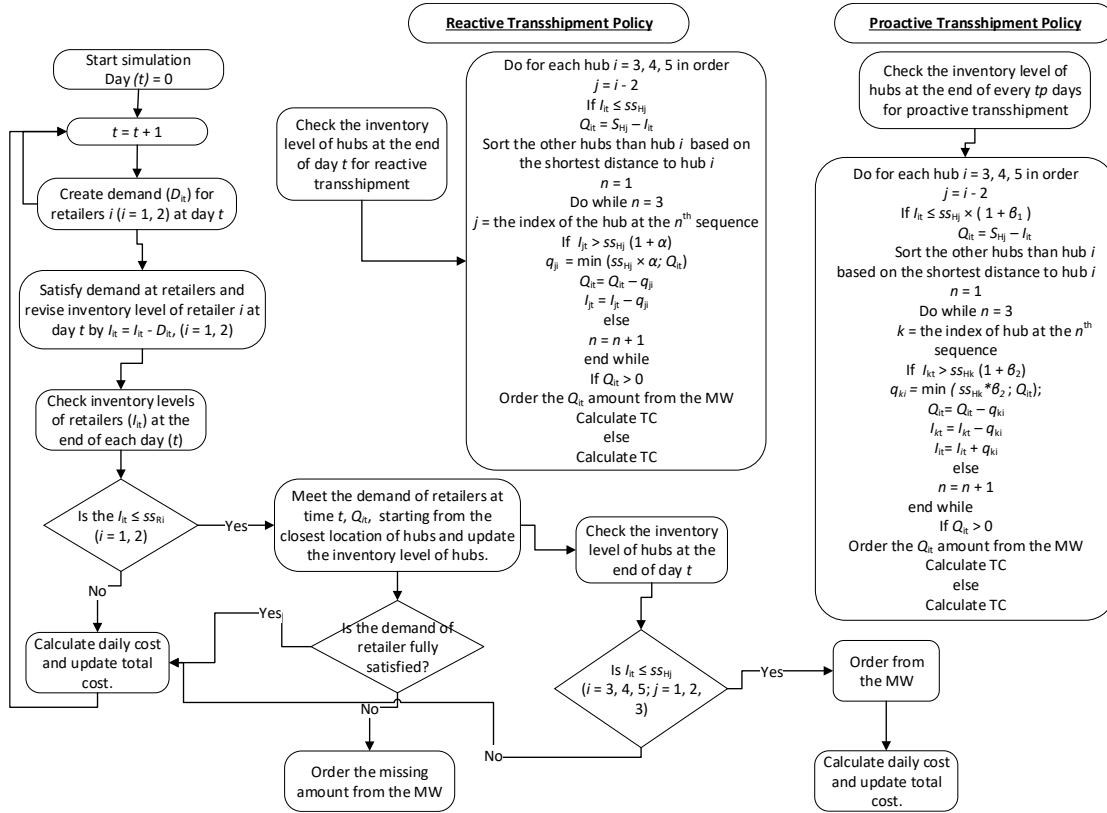

Figure 3: The Flowchart of the Simulation Model

In the simulation, an (s, S) inventory control problem is modelled. Based on that if the inventory level I_{it} is lower than or equal to safety stock level (SS_{Ri} or SS_{Hj}), an order is placed for the stocking location at day t . The order quantity, Q_{it} , is defined to be fulfilling the inventory level to up-to-levels of stocking locations, S_{Ri} or S_{Hj} . Hence, Q_{it} is equal to $S_{Ri} - I_{it}$ or $S_{Hj} - I_{it}$ (Eq. 1).

4.1 Assumptions

In this section, simulation assumptions as well as the lateral transshipment policy assumptions for reactive, proactive and hybrid policies, that are studied in the network, are summarized.

4.1.1 Reactive Transshipment Policy

Note that the detailed pseudo codes for reactive transshipment policy are given in Figure 3. In this lateral transshipment policy, the inventory share takes place when a hub's inventory level decreases to a level lower than its safety stock (SS_{Hj}) level. The reactive transshipment policy is

considered that it takes place for only hubs. Based on that, at the end of each day, the current inventory level of hubs is checked in the order of H1, H2 and H3. Based on the (s, S) inventory control problem, the order amount for lateral transshipment or MW is calculated by (1).

$$Q_{it} = \begin{cases} S_{Hj} - I_{it} & \text{if } I_{it} \leq ss_{Hj}, i = j = 3, 4, 5 \\ 0, & \text{otherwise} \end{cases} \quad (1)$$

The transshipment amount from hub j to hub i , q_{ji} , is calculated by (2):

$$q_{ji} = \min (ss_{Hj} \times \alpha, Q_{it}), \quad (2)$$

where $I_{jt} \geq ss_{Hj} \times (1 + \alpha)$. (1) and (2) together mean that, when a hub's inventory level decreases to a level lower than its safety stock level, then another hub may make lateral transshipment in the amount of α coefficient of its safety stock level or Q_{it} amount where $0 \leq \alpha \leq 1$. The minimum amount is selected to be sent by the hub.

4.1.2 Proactive Transshipment Policy

The pseudo code for proactive transshipment policy is also provided in Figure 3. Note that the review period for proactive lateral transshipment policy is tp which is also considered to be a decision variable in the optimization procedure. The proactive lateral transshipment takes place only among the hubs. Every tp day, lateral transshipment may take place when the inventory level of hub i reaches to a lower level of coefficient - β_1 - of its safety stock level: $I_{it} \leq ss_{Hj} \times (1 + \beta_1)$, where $0 \leq \beta_1 \leq 1$, $i = 3, 4, 5$. The order amount for hub i is calculated as in (1). However, the transshipment amount from hub k to hub i , q_{ki} , $k \neq i$, $k = 3, 4, 5$ is calculated by (3):

$$\text{If } I_{kt} > ss_{Hk} (1 + \beta_2) \\ q_{ki} = \min (ss_{Hk} * \beta_2; Q_{it}), \quad (3)$$

meaning that in a lateral transshipment, from a hub, β_2 times of its safety stock level or Q_{it} amount of inventory level can be sent. The minimum amount is selected to be sent by the hub.

4.1.3 Simulation Model Assumptions

The overall assumptions that are considered in the simulation models are as follows:

- Demands arrive at the retailers, R1 and R2, at the beginning of each day with stochastic amounts.
- Demand amounts for R1 and R2 are considered to be normally distributed with mean and standard deviation of (20, 5) and (30, 5), respectively.
- Retailers and hubs have capacity constraints in terms of the maximum number of items that they can store in their facilities. These values are assigned as up-to-levels of retailers (S_{Ri}) and up-to-levels of hubs (S_{Hi}) whose values are considered to be: $S_{R1} = S_{R2} = 250$; $S_{H1} = S_{H2} = S_{H3} = 750$, in Design 1 (Figure 2) and $S_{R1} = S_{R2} = 250$; $S_{H1} = S_{H3} = 1000$; $S_{H2} = 1200$, in Design 2.
- Safety stock levels of retailers and hubs, ss_{R1} , ss_{R2} , ss_{H1} , ss_{H2} , ss_{H3} , and the parameters, α , tp , β_1 , and β_2 are considered as decision variables that are to be optimized in the models.
- Holding costs for retailers and hubs are \$0.4/item and \$0.1/item, respectively.
- In transportation from the MW, trucks have load capacity of 30 units. In transshipment among hubs, trucks have load capacity of 15 units. The transportation or transshipment cost is calculated based on the number of trucks. For instance, if two trucks are sent

from the MW or a hub, then the total transportation/transshipment cost is calculated by multiplying the total km. travelled by unit travel cost and by two (number of trucks).

- The simulation models are run for two years with 60 days of warm-up period for each scenario.
- The optimization is completed by minimizing the simulation run total cost by using the OptQuest tool in ARENA 14.0 commercial software.
- No order is placed by the stocking locations if there is already on road.
- In each run, ten independent replications are completed.
- In the optimization, fill rate constraint is considered 0.95. Fill rate is defined as a rate at which customer orders can be filled from existing amount of inventory. For instance, if the customer order is 10 units, but the current inventory levels is 7 units then fill rate is 70%.
- Since it is a popular and useful variance reduction technique, Common Random Numbers (CRN) variance reduction technique is used in the simulation models. Note that in CRN, the same random number stream is used for all other configurations. Thus, variance reduction is ensured.

The OptQuest is run several times by narrowing the search space of decision variables by utilizing previous run's result as suggested solution.

5 Results

The optimization results obtained by the OptQuest are presented in Table 1. We also show the results when there is no lateral transshipment policy in the network. By utilizing the Table 1 results, the findings are summarized in Section 5.1.

Table 1: OptQuest results of transshipment policies based on two network designs

Design 1	α	β_1	β_2	tp	TC	SS_{H1}	SS_{H2}	SS_{H3}	SS_{R1}	SS_{R2}
Reactive	0.81	-	-	-	268,086	333	60	442	81	126
Proactive	-	0.44	0.01	7	300,677	340	133	601	80	121
Hybrid	0.04	0.28	0.05	5	287,399	265	44	362	81	115
No Lateral	-	-	-	-	318,495	293	26	407	81	109
Design 2	α	β_1	β_2	tp	TC	SS_{H1}	SS_{H2}	SS_{H3}	SS_{R1}	SS_{R2}
Reactive	0.88	-	-	-	417,103	361	72	406	83	130
Proactive	-	0.81	0.01	5	407,948	400	81	431	88	109
Hybrid	0.19	0.71	0.06	1	422,607	266	82	383	83	129

5.1 Results Analysis

According to Table 1, the findings from the models can be summarized as in below:

- In Design 1 network, the best transshipment policy takes place in the reactive policy.
- In Design 2 network, the best transshipment policy takes place in the proactive policy.
- When there is no lateral transshipment policy in the network (in Design 1), it has the largest total cost.

- The second hub's safety stock level is always lower compared to other hubs' safety stock levels. This is probably since this hub is located at the middle and it is the closest location to the MW. It tends to share its inventory with the other hubs in the lateral transshipment cases. Hence, by the decreased safety stock level, it carries more inventory to share with the other hubs.
- By looking at the α and β_1 values, we understand that in Design 2, due to the increased values of them, it seems that more lateral transshipment takes places. This is probably because of the fact that, in Design 2, there are higher hub capacities compared to Design 1 and due to the higher transportation cost from hubs to retailers more lateral transshipment takes place. In this design, probably lateral transshipment takes place mostly from the second hub to the others. By that, it tends to keep more inventory in the Hubs 1 and 3, which are the closer hubs to the retailers.

6 Conclusions and Discussion

In this paper, we study mainly two lateral transshipment policies: reactive and proactive in a two-echelon supply chain network. We seek the best lateral transshipment policy based on two different network designs in terms of hub capacities and transportation cost from hubs to retailers. We optimize the safety stock levels as well as some other transshipment related parameters such as α , tp , β_1 , and β_2 , by minimizing the total cost in the system. In the total cost, we consider backorder costs in retailers, transportation, transshipment costs, and holding costs in hubs and retailers.

As a result of this study, it is observed that the performance of a lateral transshipment policy strongly depends on the studied network design and its parameter values as well as how the transshipment policies are pre-defined. As a future study, we recommend more network design types to be studied with different lateral transshipment policies to test their performances. It would be also interesting to analyze the effect of the demand profile (fast or slow moving items) on the transshipment policy determination on the studied networks.

References

- Arrow K., Harris T., Marschak J. (1951). Optimal Inventory Policy, *Econometrica*, v19, no3, 250-272.
- Axsäter S. (2003a): Evaluation of unidirectional lateral transshipments and substitutions in inventory systems, *European Journal of Operational Research*, v149, no2, 438-447.
- Axsäter S. (2003b). A new decision rule for lateral transshipments in inventory systems, *Management Science*, v49, no9, 1168-1179.
- Axsäter S. (2015). *Inventory control*. Springer.
- Ballot E., Glardon R., Montreuil B. (2010): OpenFret: Contribution to the Conceptualization and Implementation of a Road-Rail Hub for the Physical Internet, *PREDIT*, France, 1-126.
- Bashyam S., Fu M. C. (1998): Optimization of (s, S) inventory systems with random lead times and a service level constraint, *Management Science*, v44, no12, 243-256.
- Bertazzi L., Speranza M.G. (2012): Inventory Routing Problems: An Introduction, *EURO Journal on Transportation and Logistics*, v1, no4, 307-326.
- Bushuev M.A., Guiffrida A., Jaber M.Y., Khan M. (2015): A Review of Inventory Lot Sizing Review Papers, *Management Research Review*, v38, no3, 283-298.
- Cachon G., Terwiesch C. (2006): *Matching supply with demand*. McGraw-Hill.
- Waller M., Williams B.D., Tokar T. (2008): A Review of Inventory Management Research in Major Logistics Journals: Themes and Future Directions, *The International Journal of Logistics Management*, v19, no2, 212-232.
- Çapar İ., Ekşioğlu B., Geunes J. (2011): A decision rule for coordination of inventory and transportation in a two-stage supply chain with alternative supply sources, *Computers & Operations Research*, v38, no12, 1696-1704.

- Diks E., De Kok A. (1996): Controlling a divergent 2-echelon network with transshipments using the consistent appropriate share rationing policy, *International Journal of Production Economics*, v45, no1-3, 369-379.
- Diks E., De Kok A. (1998): Optimal control of a divergent multi-echelon inventory system, *European Journal of Operational Research*, v111, 75-97.
- Gross D. (1963): Centralized inventory control in multilocation supply systems, *Multistage inventory models and techniques*, v1, 47-84.
- Freeman R. (1957): Ss Inventory Policy with Variable Delivery Time, *Management Science*, v3, no4, 431-434.
- Krishnan K.S., Rao V.R.K. (1965): Inventory Control in N Warehouses, *Journal of Industrial Engineering*, v16, 212-215.
- Lee H. L. (1987): A multi-echelon inventory model for repairable items with emergency lateral transshipments, *Management science*, v33, no10, 1302-1316.
- Montreuil B. (2011): Toward a Physical Internet: meeting the global logistics sustainability grand challenge, *Logistics Research*, v3, no2-3, 71-87.
- Olsson F. (2010). An inventory model with unidirectional lateral transshipments, *European Journal of Operational Research*, v200, no3, 725-732.
- Pan S., Nigrelli M., Ballot E., Sarraj R., Yang Y. (2015): Perspectives of Inventory Control Models in the Physical Internet: A Simulation Study, *Computers & Industrial Engineering*, v84, 122-132.
- Pan S., Ballot E., Huang G. Q., Montreuil B. (2017): Physical Internet and interconnected logistics services: research and applications, *International Journal of Production Research*, v55, no9, 2603-2609.
- Paterson C., Kiesmüller G., Teunter R., Glazebrook K. (2011): Inventory Models with Lateral Transshipments: A Review, *European Journal of Operational Research*, v210, no2, 125-136.
- Robinson L.W. (1990): Optimal and Approximate Policies in Multi-Period, Multilocation Inventory Models with Transshipments, *Operations Research*, v38, 278-295.
- Sarraj R., Ballot E., Pan S, Hakimi D, Montreuil B. (2014): Interconnected logistic networks and protocols: simulation-based efficiency assessment, *International Journal of Production Research*, v52, no11, 3185-3208.
- Sethi S. P., Cheng F. (1997): Optimality of (s, S) policies in inventory models with Markovian demand, *Operations Research*, v45, no6, 931-939.
- Silver E. A., Pyke D. F., Peterson R. (1998): *Inventory management and production planning and scheduling*. New York: Wiley.
- Tagaras G., Vlachos D. (2002): Effectiveness of stock transshipment under various demand distributions and nonnegligible transshipment times, *Production and Operations Management*, v11, no2, 183-198.
- Tiacci L., Saetta S. (2011). A heuristic for balancing the inventory level of different locations through lateral shipments, *International Journal of Production Economics*, v131, no1, 87-95.
- Yang Y., Pan S., Ballot E. (2015). An inventory control model with interconnected logistic services for vendor inventory management. In *Second International Conference of Physical Internet*.
- Yang Y., Pan S., Ballot E. (2017a): Innovative vendor-managed inventory strategy exploiting interconnected logistics services in the Physical Internet, *International Journal of Production Research*, v55, no9, 2685-2702.
- Yang Y., Pan S., Ballot E. (2017b): Mitigating supply chain disruptions through interconnected logistics services in the Physical Internet International, *Journal of Production Research*, v55, no14, 3970-3983.



Towards Hyperconnected Supply Chain Capability Planning: Conceptual Framework Proposal

Raphaël Oger^{1,2}, Benoit Montreuil^{2,3}, Matthieu Luras^{1,2}, and Frédérick Benaben^{1,2}

¹ Centre Génie Industriel, IMT Mines Albi, Université de Toulouse, Albi, France

² Physical Internet Center, ISYE School, Georgia Institute of Technology, Atlanta, U.S.A

³ Coca-Cola Chair in Material Handling and Distribution, Supply Chain & Logistics Institute,
Georgia Institute of Technology, Atlanta, U.S.A

Corresponding author: raphael.oger@mines-albi.fr

Abstract: *This paper is to drive research towards a methodology that will enable organizations to foster high performance when planning their supply chain capabilities in the Physical Internet (PI) era. It first introduces the relevant concepts to understand the specificities of performing Supply Chain Capability Planning (SCCP) in the PI era and deduces two enablers: hyperconnectivity and automation. Second, it assesses the relevance of the Sales and Operations Planning (S&OP) methodology to perform SCCP in the PI era and concludes that it would not be sufficient. Consequently, it third introduces the Hyperconnected Supply Chain Capability Planning (HSCCP) methodology and the associated conceptual framework proposal, aiming to fill the gaps left by the S&OP methodology to perform SCCP in the PI era. It finally concludes leading the limitations of this paper towards avenues for future research.*

Keywords: *Hyperconnectivity, Physical Internet, Supply Chain Capability Planning, Sales and Operations Planning, Integrated Business Planning, Information Systems, Decision Support Systems, Automation, Agility, Logistics Network.*

1 Introduction

An organization may have multiple strategies to be competitive. When the organization's strategies are established, it must make plans to drive its future. Depending on their granularity and planning horizon, these are often categorized as strategic plans for the forthcoming years, and tactical plans for the forthcoming months. A common methodology used by organizations to build and manage these plans is called Sales and Operations Planning (S&OP) (Ling and Coldrick, 2009; Ling and Goddard, 1988)). The main objective of the S&OP methodology is to drive organization's teams towards a set of plans (sales, marketing, development, manufacturing, sourcing, and financial) aligned with the strategy and coherent between each other. Another name more recently introduced is Integrated Business Planning (IBP), which basically corresponds to the S&OP methodology when the implementation has reached a certain level of maturity (Bower, 2012). Thus, only the term S&OP will be used throughout this paper.

Since the Physical Internet (PI) was introduced (Montreuil, 2011), it gained significant attention from both the academic and practitioners communities (Treiblmaier et al., 2016). The PI is to design an open global logistics system that enable to manage logistics flows (material, information and money) in a way inspired from the way the digital internet deals with data flows (Montreuil et al., 2012). Simmer et al. (2017) highlighted the importance for supply chain actors to collaborate when planning their activities in the PI era, giving the S&OP process as an example of planning activity. It concluded with the need for future research in solutions to support collaboration in the PI era, highlighting the information system aspect.

This paper focuses on supply chain planning in the PI era and has a double purpose: the first is to highlight the limitations of the existing S&OP methodology and associated information systems to foster high performance in the PI environment. The second and main purpose of this paper is to introduce the foundation stone for a new methodology taking advantage of the PI paradigm: Hyperconnected Supply Chain Capability Planning (HSCCP).

The paper first positions the relevant concepts of Supply Chain Capability Planning (SCCP), the PI, and hyperconnected supply chains. Second, it provides a systematic review of S&OP, with a focus on associated information systems to support decisions and its usability in a PI environment. Based on the systematic review, limitations are identified regarding the S&OP methodology to perform in the PI environment. Third, it introduces the proposed Hyperconnected Supply Chain Capability Planning (HSCCP) methodology and associated conceptual framework. Finally, the paper provides insights for industry and avenues for future research regarding HSCCP.

2 Background and research statement

As indicated by its name, the proposed HSCCP methodology that will be introduced in section 4 suggests making business planning revolve around supply chain capabilities. In addition, it is designed to perform with hyperconnected supply chains of the PI era. So, this first section is to first position the relevant concepts of supply chain capability planning, the physical internet, and hyperconnected supply chains. Second, it is to identify Supply Chain Capability Planning (SCCP) enablers to perform in the PI era.

2.1 Physical Internet, hyperconnectivity, and supply chain capabilities

First, the Physical Internet has been introduced by Montreuil (2011) and defined as a hyperconnected global logistics system enabling seamless open asset sharing and flow consolidation through standardized encapsulation, modularization, protocols and interfaces (Montreuil, 2015; Montreuil et al., 2013). As expressed by Montreuil (2015), it is said to be hyperconnected as its components (agents, containers, facilities, etc.) are intensely interconnected on multiple layers, ultimately anytime, anywhere. The interconnectivity layers of the PI notably include digital, physical, operational, business, legal and personal layers. The network of stakeholders being part of the PI system is referred as the logistics web. Montreuil et al. (2013) describes this logistics web as a network of openly interconnected logistics networks and service providers.

Second, putting aside several references from the field of mathematics and biology, the oldest use of the term hyperconnectivity about information systems interconnection that has been found was by Quan-Haase and Wellman (2005). Focusing on computer mediated communication, Quan-Haase and Wellman (2006) define the hyperconnectivity as “the availability of people for communication anywhere and anytime”. In this paper, the supply chain hyperconnectivity must be understood as the availability of supply chain stakeholders’ information systems for communication anywhere and anytime (i.e. the availability of the information shared by all supply chain stakeholders, anywhere and anytime). Consequently, we get back to the definition of the hyperconnectivity in the PI, as availability of the information shared by all its components, anywhere and anytime.

Third, a supply chain capability of a PI stakeholder (private logistics network or individual organization) is defined as the combination of an ability (i.e. know-how) and the associated capacity that contributes to the utilization of this ability (i.e. the availability of the required resources). For example, an organization could have the capability of producing a specific smart

and modular PI containers. This capability would be made possible by having the ability (i.e. the know-how) to produce it; and by having the corresponding capacity that could be deduced from the availability of the equipment needed to produce it plus the availability of the people having the right skills to use this equipment. Figure 1 illustrates the definition of supply chain capabilities. A capability as seen by other stakeholders of the PI logistics web can correspond, from the capability owner viewpoint, to a combination of more than one internal ability and associated capacity (i.e. sub-capabilities). This depends on the granularity of the information a stakeholder wants to share about its capabilities. Consequently, from the given definition of a supply chain capability, this paper defines Supply Chain Capability Planning as the activity of planning abilities and associated capacities. For an organization, the objective of SCCP is to make decisions about what to do in the future regarding the capabilities it already has and the one it could need. Decisions about organization's capabilities can be either to provide it internally, to outsource, both, or even not providing it. For example, when an organization absolutely needs a new capability it must choose between investing in developing the corresponding ability and acquiring the corresponding resources, or outsourcing the capability, or both. Another example, when an organization needs more capacity about a capability it already has in order to meet the increasing demand, it must choose between investing in more capacity, outsourcing this additional capacity, both, or even not meeting the demand.



Figure 1: Definition of the supply chain capabilities as the combination of supply chain abilities and the associated supply chain capacities that contributes to the utilization of these supply chain abilities.

2.2 Enablers to perform supply chain capability planning in the Physical Internet era

The dynamicity of today's supply chain environment is constantly increasing, the supply chain environment is changing at such pace that organizations can struggle to keep track and respond to the evolutions (Harrington et al., 2010). For example, on strategic planning, Melnyk et al.(2014) considers that reviewing supply chain design every 5–10 years is no longer adequate and that dynamic reconfiguration is needed. In addition, as mentioned in the previous subsection, the PI implies the hyperconnection of all its components and so all its stakeholders (Montreuil, 2015). So, it would enable PI stakeholders to access and share information about their supply chain environment anywhere anytime. Combining both these elements, the hyperconnection and the dynamicity of the supply chain environment, leads us to PI stakeholders hyperconnected to a fast-changing supply chain environment they must deal with. But organizations cannot manually manage such amount of dynamic information, and so could not take all of it into account when making decisions about their supply chain capabilities plan. Therefore, a solution to enable PI stakeholders to consider all relevant information into account when making decisions about their supply chain capabilities plan would be the automation of as much SCCP analysis as possible. Automation to enable to consider the high volume of information, and to enable to keep track of the fast-changing information.

Finally, this subsection identified the following two enablers to perform SCCP in the PI era:

1. Hyperconnectivity, to make information about PI stakeholders available anywhere and anytime (being intrinsic to the PI definition).
2. Automation, to deal with high volume of fast-changing information.

2.3 Research Statement

The two preceding subsections positioned the background defining important concepts and identifying enablers to perform SCCP in the PI era. It leads to the following two research questions that structure this paper:

1. Are traditional SCCP methodologies as Sales and Operations Planning (S&OP) appropriate to perform in the PI era?
2. If the answer to the first question is “no”, what would be the evolutions needed to design an appropriate methodology?

The following two sections are structured according to both these research questions.

3 Is the Sales and Operations Planning methodology appropriate to perform in the Physical Internet era?

This section is to identify if organizations could use Sales and Operations Planning (S&OP) to plan their supply chain capabilities in the Physical Internet (PI) era. The first subsection gives an overview of the S&OP methodology and to what extent it enables organizations to plan their supply chain capabilities. Then, the second subsection challenge the S&OP methodology according to the Supply Chain Capability Planning enablers to perform in the PI era.

3.1 Sales & Operations Planning

To start with S&OP, the following quote from the S&OP definition of the APICS dictionary gives an overview of the purpose of S&OP (Blackstone and Jonah, 2013):

“A process to develop tactical plans that provide management the ability to strategically direct its businesses to achieve competitive advantage on a continuous basis by integrating customer-focused marketing plans for new and existing products with the management of the supply chain. The process brings together all the plans for the business (sales, marketing, development, manufacturing, sourcing, and financial) into one integrated set of plans. S&OP is performed at least once a month and is reviewed by management at an aggregate (product family) level. The process must reconcile all supply, demand, and new product plans at both the detail and aggregate levels and tie to the business plan. It is the definitive statement of the company's plan for the near to intermediate term, covering a horizon sufficient to plan for resources and to support the annual business planning process.”

S&OP was created back in 1984 by Richard (Dick) Ling (Ptak and Ling, 2017). Its first appearance in the literature was in 1988 within the book ‘Orchestrating success: Improve control of the business with sales & operations planning’ (Ling and Goddard, 1988). The S&OP process proposal made in 1988 was then updated in 2003 and 2009 (Coldrick et al., 2003; Ling and Coldrick, 2009), Figure 2 illustrates this latter S&OP process proposal. Three main changes were emphasized between the first proposal and the latter: First is the appearance of an emphasis on alignment. The alignment of all the plans (sales, marketing, development, manufacturing, sourcing, and financial) with the business strategy, shifting from a left to right unidirectional process to a bidirectional process that explains the process loops illustrated in Figure 2. This alignment with the business strategy is represented by the arrows from the senior

business management review activity to the three following activities: managing new activities, managing demand, and managing supply. Depending on this business strategy, teams will focus on different Key Performance Indicators (KPIs) to make decisions about these plans. Second is the addition of a step to consider managing new activities in addition of the existing portfolio. Third is the shift from a linear process to a process centered on integrated reconciliation. The integrated reconciliation step is to ensure the coherence between all the plans, and to take into consideration their interdependencies (Ling and Coldrick, 2009; Piñón, 2017). This integrated reconciliation is represented on Figure 2 by both the big arrow containing this term and the arrows between the three following activities: managing new activities, managing demand, and managing supply. Four structural categories of components are identified from the descriptions of the S&OP methodology: first, the stakeholders who are undertaking each activity of the S&OP process. Second, the information sharing principles that feed each activity with the needed information. Third, the information usage that corresponds to the completion of each activity. Fourth, the activities frequency that depends of the frequency of the S&OP process loop.

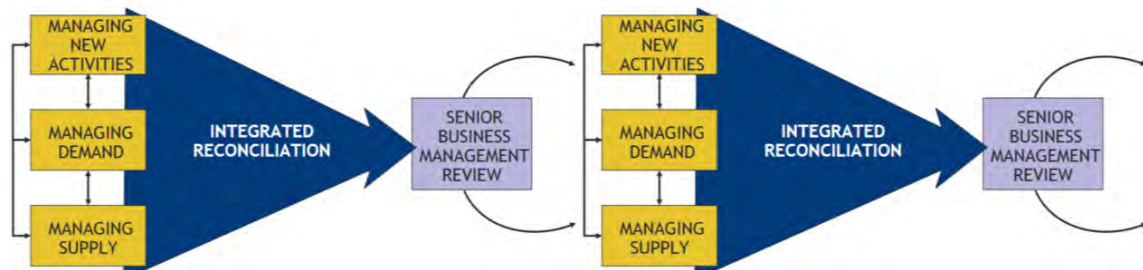

Figure 2: Sales and Operations Planning process (adapted from Coldrick et al. (2003))

As previously mentioned, the definition of the S&OP methodology suggests driving business decisions through the creation of several plans for the business. Implementing these plans include important business decisions such as asset investments and location (e.g. facilities, equipment, human resources, and inventories), asset allocation (e.g. human resource, and financial), partnerships (e.g. suppliers and subcontractors selection), core asset maintenance scheduling (e.g. planning maintenance according to production needs), promotion scheduling (e.g. planning promotions according to anticipated extra capacity of resources), product portfolio and associated priorities (e.g. deciding whether or not launching a new product), and product design and technology choices (e.g. to design a product considering its impact on the supply chain). All these decisions concern the internal supply chain capabilities of the business. It is all about planning the supply chain capabilities and actions that relies on these supply chain capabilities, to fit the business strategy (Lapide, 2004; Ling and Coldrick, 2009).

3.2 Limitations of the Sales & Operations Planning methodology to perform in the Physical Internet era

To create the plans recommended by the S&OP methodology, organizations must implement a process enabling them to manage the information needed to create these plans. From a high-level perspective, the S&OP methodology gives guidelines on how to organize this process. However, Tuomikangas and Kaipia (2014) highlighted that companies lack guidelines and advice about how to implement S&OP. An emphasis is made on technological solutions, saying that the literature on technological proposal to support S&OP is still in its early stage. Tuomikangas and Kaipia (2014) conclude that conceptual and empirical literature on technological solutions to support S&OP deserves future research with a new type of thinking and process design covering strategic business targets. In addition, all S&OP maturity models

analyzed to write this paper point out that information technology plays a key role to reach high-level of S&OP maturity (Cecere et al., 2009; Grimson and Pyke, 2007; Lapede, 2005; Viswanathan, 2010; Wing and Perry, 2001). Tavares Thomé et al. (Tavares Thomé et al., 2012) and Tuomikangas and Kaipia (2014) did the same observation that advanced information systems are viewed as essential to align strategies and operations when moving towards advanced S&OP stages. Consequently, the combination of both these previous elements, the importance of information technology solutions to reach high S&OP maturity and the lack of literature on it, show a gap in the S&OP literature.

A major obstacle for organizations to use S&OP to plan their capabilities in the PI era comes out bringing together the following two elements: first, the gap of information technology solutions to support S&OP. Second, the Supply Chain Capability Planning (SCCP) enablers identified in the second section being hyperconnection and automation. The S&OP literature does not provide information technology solutions neither for the hyperconnection requirement to make information about PI stakeholders available anywhere and anytime, nor the automation requirement to deal with high volume of fast-changing information. Therefore, the current S&OP literature does not provide solutions to perform SCCP in the PI era.

4 A proposal for organizations to perform Supply Chain Capability Planning in the Physical Internet era: Hyperconnected Supply Chain Capability Planning

This section is to introduce a proposal for organizations to perform Supply Chain Capability Planning (SCCP) in the Physical Internet (PI) era: Hyperconnected Supply Chain Capability Planning (HSCCP). The HSCCP conceptual framework proposal introduced in this section aims to be the foundation stone that describes the main concepts of the HSCCP methodology, and how it approaches SCCP to fill the gaps identified with the S&OP methodology. It is composed of three main structural concepts (Figure 3) inspired from the four that were identified in the description of the Sales and Operations Planning (S&OP) methodology: first are the stakeholders, second are the information sharing principles, and third are the information usage principles. These three HSCCP concepts are described in the three following subsections. The fourth element, frequency, identified in the description of the S&OP methodology were not kept for the HSCCP. Because it is considered as part of the information sharing and information usage through the hyperconnection and dynamicity principles that will be introduced.

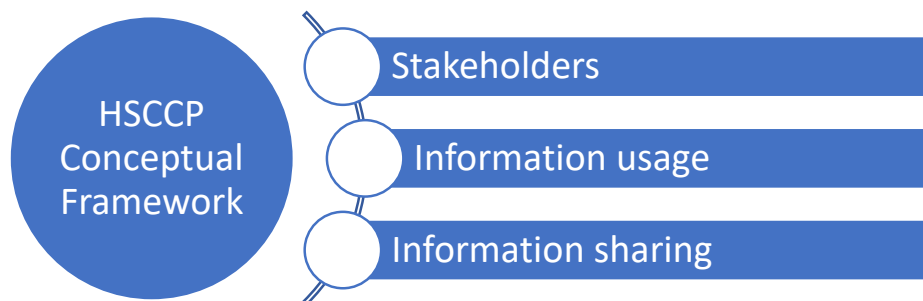

Figure 3: Main structural concepts of the Hyperconnected Supply Chain Capability Planning conceptual framework proposal

4.1 HSCCP Stakeholders

There are two levels of HSCCP stakeholders. First is the network level, it corresponds to the entities providing supply chain capabilities across the PI network. The rest of the paper will

refer to these entities as PI stakeholders, it can be entities such as individual manufacturing companies, haulage contractor, or private logistics networks. Second is the private level, it corresponds to the internal organization of a PI stakeholder, teams that are involved in the HSCCP. The list of these internal teams has been taken from the S&OP methodology: sales, marketing, development, manufacturing, sourcing and finance teams. The rest of the paper will refer to these private level stakeholders as internal stakeholders. These two levels of HSCCP stakeholders are illustrated in Figure 4. Note that in some cases such as private logistics networks, an additional intermediate level within the private level might be to consider.

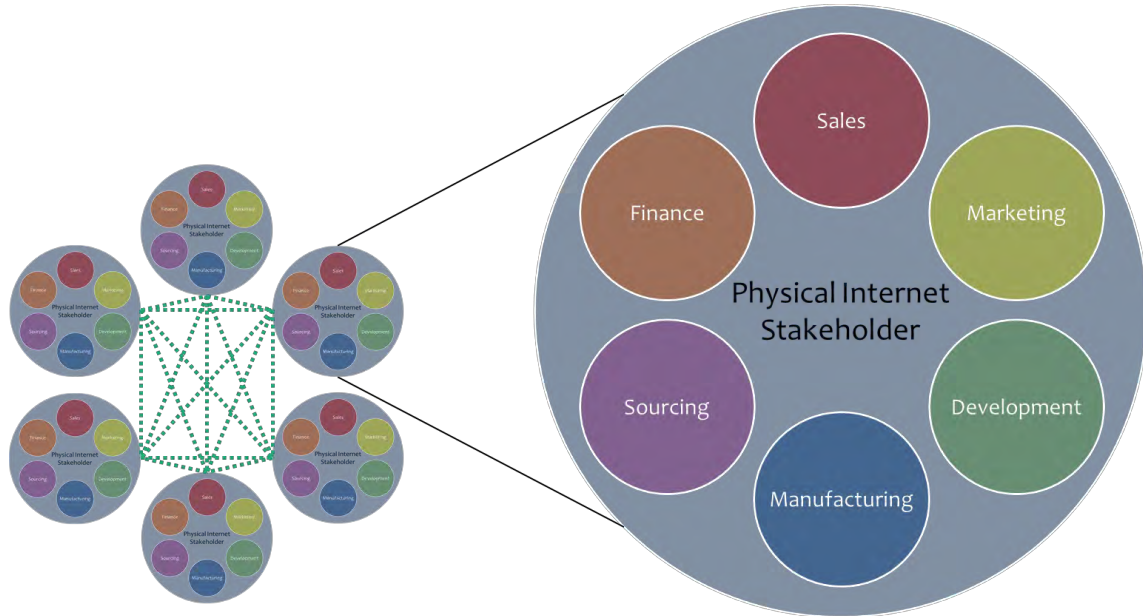

Figure 4: Illustration of the two levels of stakeholders considered for Hyperconnected Supply Chain Capability Planning: the network level (PI stakeholders) and the private level (sales team, manufacturing team, etc.)

4.2 HSCCP information sharing principles

HSCCP information sharing is based on two elements: first is communication and second is information. These two elements are described within the following two subsections.

4.2.1 HSCCP communication principles

The communication solution must support the following principles: openness, hyperconnection, data privacy, and modularity. The first two principles, openness and hyperconnection, are to give to every single organization the ability to communicate anywhere anytime. The third principle, data privacy, is one of the pillars of communication technologies. To reassure organization about it, communication security must be ensured. In addition, organizations must be able to choose to what extend they will share information. Indeed, the fourth and last principle, modularity, is to ensure information sharing modularity through the possibility to establish modular information sharing policies and contracts.

4.2.2 HSCCP information flows

Bringing together the previously given definitions of SCCP and hyperconnectivity, Figure 5 illustrates the main categories of information flows to perform HSCCP from the point of view

of a PI stakeholder. It contains two types of information flows, both being necessary to perform SCCP: the first is external information sharing, corresponding to information shared with other PI stakeholders and information received from other PI stakeholders. The second is internal information about objectives and capabilities.

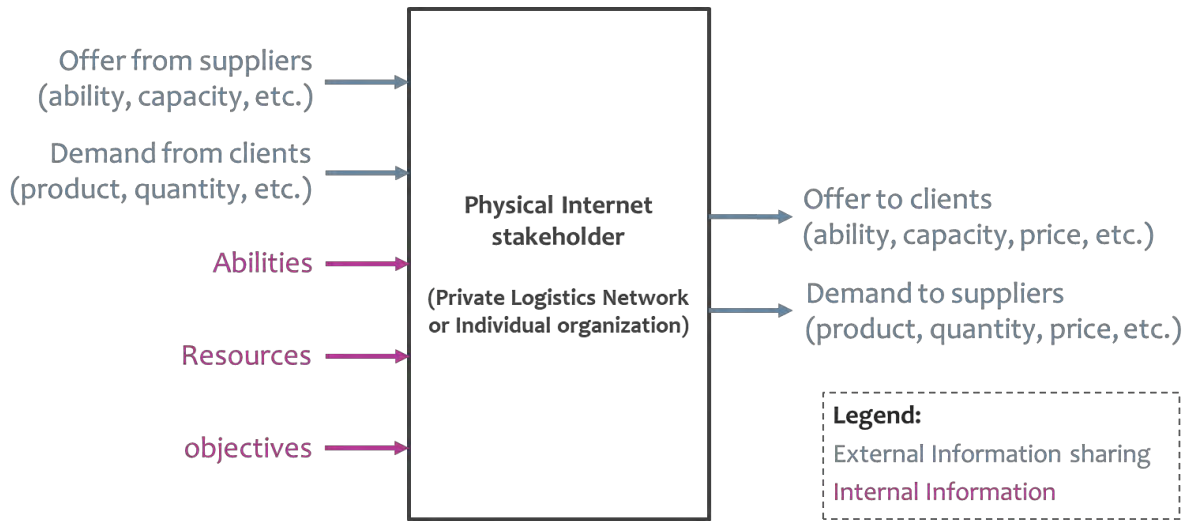

Figure 5: Illustration of the main information flows for Hyperconnected Supply Chain Capability Planning, as seen from the viewpoint of a Physical Internet stakeholder

4.3 HSCCP information usage principles

The hyperconnectivity opens the way for organizations to rethink the way they manage their SCCP activities, and the HSCCP proposal intend to take advantage of it. This subsection is to explain how the HSCCP methodology suggests to organizations to rethink the way they manage their SCCP activities, assuming the information sharing principles described in the previous subsection are satisfied. Figure 6 illustrates the essence of how the HSCCP methodology proposal suggest rethinking the way organizations use information to plan their supply chain capabilities. It is considered as the core of the HSCCP methodology proposal and so is presented as the main illustration of the HSCCP conceptual framework. This HSCCP conceptual framework is built around the principle of agility and dynamicity. The idea is to make SCCP as dynamic as the supply chain environment. It has been divided into two objectives inspired from the definition of agility suggested by Barthe-Delanoë et al. (2014, 2018): first, on the left part, is the dynamic detection of evolutions that impact supply chain capability plans. Second, on the right part, is the dynamic adaptation of supply chain capability plans to evolutions. Both these objectives are related, the second one relying on the outcomes of the first one. Both these objectives are similarly decomposed in three types of sub-objectives: detection, assessment, decision. They will both be explained in the following paragraphs.

The first objective, dynamic detection of evolutions that impact supply chain capability plan, relies on the information sharing principles to get information from PI stakeholders and internal stakeholders. It is to provide the second objective, dynamic adaptation of supply chain capability plans to evolutions, with the information that according to the detected supply chain environment evolutions it could be needed to adapt the supply chain capability plans. This first objective is composed of the three following sub-objectives: first is the detection of evolutions, it corresponds to detecting evolutions in the supply chain environment coming from other PI stakeholders as well as internal stakeholders. Second is the impact assessment of evolutions, it corresponds to assessing the impact of the detected evolutions on the supply chain capability plans. Third is the deduction of potential needs for adaptation, it corresponds to deducing

potential needs for adaptation of the supply chain capability plans considering the detected supply chain environment evolutions.

The second objective, dynamic adaptation of supply chain capability plans to evolutions, is triggered according to the first objective outcome. It is only triggered if the outcome of the first objective is that there are potential needs for adaptation of the supply chain capability plans. It is to make decisions about potential changes in the supply chain capability plans considering the detected supply chain environment evolutions. This second objective is composed of the three following sub-objectives: first is the identification of adaptation alternatives, it corresponds to identifying the set of possible supply chain capability plans alternatives to adapt to the detected supply chain environment evolutions. Second is the performance assessment of adaptation alternatives, it corresponds to assessing the performance of the supply chain capability plans adaptation alternatives. It must enable the evaluation of supply chain structural changes. Third is the decision of the adaptation alternative to implement, it corresponds to deciding about the supply chain capability plans to implement, relying on the assessment of the adaptation alternatives, to adapt to the detected supply chain environment evolutions.

Looking towards functional and technological solutions, to reach these conceptual framework objectives built around the principle of dynamicity, the solution must satisfy, at least partially if not entirely, the two SCCP enablers identified in the second section of this paper: hyperconnectivity and automation. The conceptual framework has been designed in this sense.

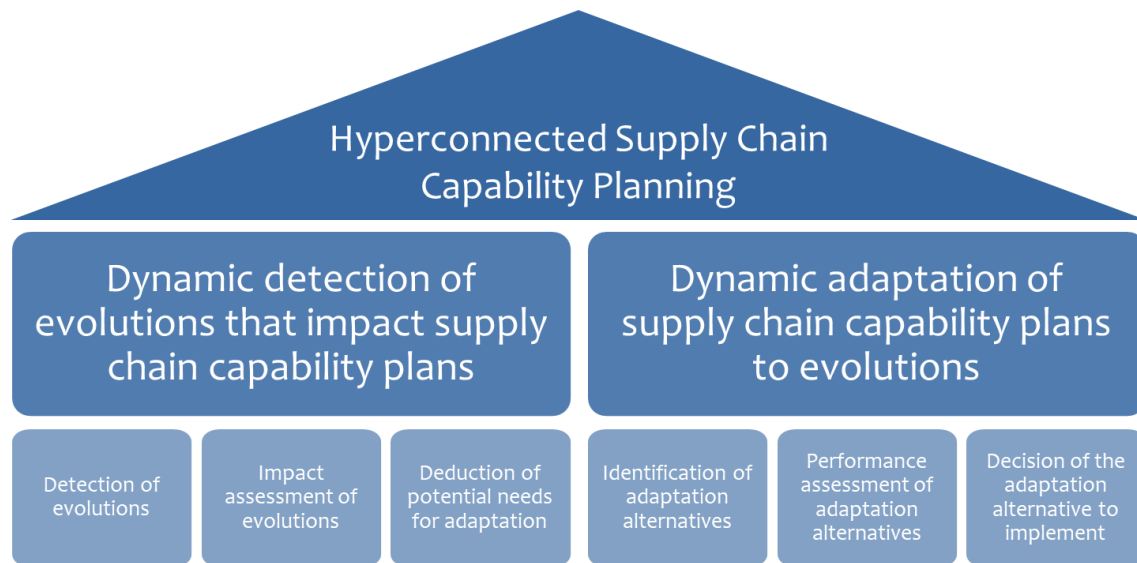

Figure 6: Core of the Hyperconnected Supply Chain Capability Planning conceptual framework

5 Conclusion and avenues for future research

This paper is to support the realization of Supply Chain Capability Planning (SCCP) in the Physical Internet (PI) era. It first introduced the relevant concepts to understand SCCP and the specificities of the PI era, and it deduced two enablers to perform SCCP in the PI era: hyperconnectivity and automation. Second, it assessed the relevance of the Sales and Operations Planning (S&OP) methodology to perform SCCP in the PI era. It concluded that the S&OP methodology as it currently exists would not be enough to perform SCCP in the PI era. The S&OP literature does not provide information technology solutions or guidelines neither for the hyperconnection nor the automation requirements. Consequently, the need for a methodology filling these gaps was highlighted. Therefore, it third introduced the

Hyperconnected Supply Chain Capability Planning (HSCCP) methodology proposal with its conceptual framework. This HSCCP methodology aims to fill the previously mentioned gaps of the S&OP methodology to perform in the PI era.

The study presented in this paper has some limitations that are important to keep in mind. First, only the S&OP methodology (also known as Integrated Business Planning) has been analyzed and challenged because it was considered as the most common methodology used by organizations to perform SCCP. It would be beneficial to have the same approach for methodologies such as Collaborative Forecast and Replenishment (CPFR) and Adaptive S&OP. Second, Supply Chain Risk Management (SCRM) was not mentioned in the study, it could be interesting to integrate it within the conceptual framework. An additional research avenue would be the completion of this HSCCP conceptual framework proposal going more in depth into the description of each element.

Finally, the HSCCP conceptual framework described in this paper could be part of a set of three frameworks to fully design the HSCCP methodology proposal: First, the conceptual framework describing the main concepts of the HSCCP methodology and how it approaches SCCP. Second, a functional framework to describe how this methodology can be used by organizations and their teams to plan their supply chain capabilities. Third, a technological framework to describe how information technology can meet the expectations and challenges of the conceptual and functional frameworks. All together these three frameworks are to give a full description of the HSCCP methodology, giving organizations enough information and guidelines to implement it.

6 Acknowledgments

This research project is possible thanks to the support of the Pierre Fabre laboratories through a research chair set up with IMT Mines Albi and dedicated to supply chain agility.

References

- Barthe-Delanoë, A.-M., Montarnal, A., Truptil, S., Bénaben, F., Pingaud, H., 2018. Towards the agility of collaborative workflows through an event driven approach – Application to crisis management. *International Journal of Disaster Risk Reduction* 28, 214–224.
<https://doi.org/10.1016/j.ijdr.2018.02.029>
- Barthe-Delanoë, A.-M., Truptil, S., Benaben, F., Pingaud, H., 2014. Event-driven agility of interoperability during the Run-time of collaborative processes. *Decision Support Systems* 59, 171–179.
- Blackstone, J.H., Jonah, J., 2013. *APICS Dictionary: The Essential Supply Chain Reference*. American Production and Inventory Control Society (APICS), Chicago.
- Bower, P., 2012. Integrated Business Planning: Is It a Hoax or Here to Stay? *The Journal of Business Forecasting* 31, 11–17.
- Cecere, L., Barrett, J., Mooraj, H., 2009. *Sales and operations planning: transformation from tradition. Industry Value Chain Strategies*. AMR Research, Boston, MA, USA.
- Coldrick, A., Ling, D., Turner, C., 2003. *Evolution of Sales & Operations Planning-From Production Planning to Integrated Decision Making*. Strata Bridge.
- Grimson, J.A., Pyke, D.F., 2007. Sales and operations planning: an exploratory study and framework. *The International Journal of Logistics Management* 18, 322–346.
<https://doi.org/10.1108/09574090710835093>
- Harrington, L.H., Boyson, S., Corsi, T., 2010. *X-SCM: The New Science of X-treme Supply Chain Management*. Routledge.
- Lapide, L., 2005. Sales and operations planning Part III: a diagnostic model. *The Journal of Business Forecasting* 24, 13.
- Lapide, L., 2004. Sales and operations planning part I: the process. *The Journal of business forecasting* 23.

- Ling, D., Coldrick, A., 2009. Breakthrough Sales & Operations Planning: How we developed the process.
- Ling, R.C., Goddard, W.E., 1988. Orchestrating success: Improve control of the business with sales & operations planning. Oliver Wight Limited Publications.
- Melnyk, S.A., Narasimhan, R., DeCampos, H.A., 2014. Supply chain design: issues, challenges, frameworks and solutions. *International Journal of Production Research* 52, 1887–1896. <https://doi.org/10.1080/00207543.2013.787175>
- Montreuil, B., 2015. The Physical Internet: A Conceptual Journey, Keynote Presentation. 2nd International Physical Internet Conference (IPIC), Paris, France.
- Montreuil, B., 2011. Toward a Physical Internet: meeting the global logistics sustainability grand challenge. *Logistics Research* 3, 71–87. <https://doi.org/10.1007/s12159-011-0045-x>
- Montreuil, B., Meller, R.D., Ballot, E., 2013. Physical Internet Foundations, in: *Service Orientation in Holonic and Multi Agent Manufacturing and Robotics, Studies in Computational Intelligence*. Springer, Berlin, Heidelberg, pp. 151–166. https://doi.org/10.1007/978-3-642-35852-4_10
- Piñón, D., 2017. Are Existing Strategic Supply Chain Planning Methodologies Sufficient to Prepare Supply Chains to Perform in Today's Challenging Market Conditions? (Master Thesis). IMT Mines Albi, Albi, France.
- Ptak, C., Ling, D., 2017. Adaptive Sales & Operations Planning - Embracing Change and Driving Adaptation. Presented at the Adaptive S&OP workshop, IMT Mines Albi & Agilea, Albi, France.
- Quan-Haase, A., Wellman, B., 2006. Hyperconnected Net Work: Computer-Mediated Community in a High-Tech Organization, in: *The Firm as a Collaborative Community: Reconstructing Trust in the Knowledge Economy*. Charles Heckscher and Paul Adler with Oxford University Press, pp. 281–333.
- Quan-Haase, A., Wellman, B., 2005. How Computer-Mediated Hyperconnectivity and Local Virtuality Foster Social Networks of Information and Coordination in a Community of Practice, in: *International Sunbelt Social Network Conference*.
- Simmer, L., Pfoser, S., Grabner, M., Schauer, O., Putz, L.M., 2017. From horizontal collaboration to the Physical Internet—a case study from Austria. *International Journal of Transport Development and Integration* 1, 129–136.
- Tavares Thomé, A.M., Scavarda, L.F., Fernandez, N.S., Scavarda, A.J., 2012. Sales and operations planning: A research synthesis. *International Journal of Production Economics* 138, 1–13. <https://doi.org/10.1016/j.ijpe.2011.11.027>
- Treiblmaier, H., Mirkovski, K., Lowry, P.B., 2016. Conceptualizing the Physical Internet: Literature Review, Implications and Directions for Future Research.
- Viswanathan, N., 2010. Sales and Operations Planning: Strategies for Managing Complexity within Global Supply Chains 28.
- Wing, L., Perry, G., 2001. Toward twenty-first-century pharmaceutical sales and operations planning. *Pharmaceutical Technology* 20–20.



LogiPipe: A vision to close the Physical Internet's last-mile gap while improving city health and prosperity

Balthasar Schönangerer¹ and Daniel Tinello¹

¹Institute of Logistics Engineering, Graz University of Technology, Graz, Austria
Corresponding author: Daniel Tinello (daniel.tinello@tugraz.at)

Abstract: *This paper describes the urban transport of goods, which will also increase steadily in the future due to the continual growth of the e-commerce sector. The focus is on the last-mile distribution of packages from the city hubs of the Internet, which are located in the periphery of large cities, to the center. Our vision is one of underground tubes, in which electrically driven transport capsules move goods that are stored in pi-boxes. We have named this vision of tubular networks, a logistics pipeline, **LogiPipe**. This method of inner-city freight transport offers a number of significant advantages. On the one hand, delivery traffic and costs are greatly reduced and accordingly harmful emissions such as noise and fine dust. On the other hand, less valuable open spaces (e.g., for parking lots or loading zones) will be sacrificed. As a result, the potential for environmental damage is reduced and people's well-being can be increased.*

Keywords: *Tube logistics, City logistics, Last-mile delivery, Modular containers, Supply Network, Transportation, Resource efficiency, Air pollutants, Business model innovation.*

1 Introduction – connections between e-commerce, city logistics and health

Many areas of society have changed drastically in recent years and will continue to do so in the future. Various trends, which are explained below, influence daily life and should be taken into account early on in the process of planning new concepts.

Currently, a megatrend is progressive urbanization, i.e., the resettlement of populations from the countryside to cities or conurbations. According to an OECD estimate, around 66% of the world's population will live in urban areas by 2050 (OECD, 2017). Basically, this means that free space in urban areas will become increasingly scarce and population density will increase locally. This trend toward moving into densely populated areas leads to a high demand for properties, which is reflected by the recent enormous increase in property values. To take this development into account, it is necessary to take measures such as densified housing construction.

Two further megatrends are ongoing globalization and steadily increasing connectivity. Today, products are purchased all over the world and no longer only from local retailers. Combined with digitalization, consumer behavior has changed drastically in both western industrialized countries and in countries in Asia. The share of e-commerce is also constantly increasing and will continue to do so in the future. More and more people, and especially the elderly, are choosing to make retail purchases online and, above all, appreciate the convenience of having goods delivered directly to their doorstep. Smartphones, design-optimized shopping apps and new cashless payment methods mean that shopping is now possible anytime and anywhere. In the USA, almost 25% of revenue from e-commerce was shown to have been generated from a portable device in 2017 (Statista, 2017).

The circumstances described above inevitably result in a huge increase in the package volume, which will continue to increase in the future. The distribution channels and buyer behavior have

changed significantly in the past, but parcel delivery on the last mile by so-called CEP (courier, express and parcel) service providers has remained almost unchanged. This has resulted in a considerable increase in delivery traffic over the past decade, especially in densely populated areas. In certain areas, and mostly urban areas, this has already caused major problems (TZ, 2017). Due to the high number of parcels and precarious conditions in the parcel-service sector, it is currently customary to deliver parcels late into the night. Furthermore, traffic consumes valuable land that is already scarce in urban areas. Nearly every day, trees and green spaces are being sacrificed to create new roads, parking lots and loading areas. The inhabitants in these areas lack local recreation zones, which has a negative effect on their well-being and, thus, on their psyche. This results in lowered resistance to stress and diseases of all kinds, and the number of sick days taken by members of the population increases. This is then expressed in the form of a deterioration in the overall economic performance of a region, which endangers the upper level of prosperity in the long term (Schrampf et al., 2013; European Environment Agency, 2016; Etezadzadeh, 2015). Admittedly, the effects described above are something exaggerated as formulated, but have been described in the findings of several studies by EU institutions (ALICE, 2018). Another daily example, which can easily be observed, is the delivery of parcels, which is permitted in traffic-calming zones for only short periods of time. This process often leads to a chaotic traffic conditions. If the delivery process is negative (i.e., the parcel cannot be delivered to the destination), another delivery attempt will follow or the recipient will be asked to pick up the parcel personally, which increases the traffic of individuals. If you consider carefully why traffic-calming zones are being introduced—to put it briefly and succinctly, to improve the quality of life—you will quickly become aware that new solutions are needed.

The effects described above affect people indirectly and respectively in that they are annoying, but other dangers also exist. Traffic produces harmful health hazards such as fine dust and noise. There are manifold effects of noise and air pollutants on humans. If people are exposed to these emissions for longer periods of time, chronic diseases often develop (Science for Environment Policy, 2016). This means that intensive medical care, which is expensive, will be necessary.

To counteract all these negative developments, new solutions are needed in the field of mobility. Reducing delivery traffic alone will not be sufficient to solve all these problems, but every piece in the puzzle is important.

2 LogiPipe – a proposed solution in urban areas

To solve the problems described above, the Institute of Logistics Engineering at the Graz University of Technology has developed the concept of a logistics pipeline (LogiPipe) network for urban freight transport. Figure 1 shows the different components required for the network. The basic structure of LogiPipe consists of underground pipes in which electrically and intelligently driven transport capsules transport goods to their destinations. The switches of the tubes are set automatically by communication with integrated RFID chips in the packages. Therefore, no central control system is necessary. The size of the capsule is selected so that approx. 80% of daily parcel deliveries can be processed with LogiPipe. Bulky goods must, therefore, continue to be delivered by CEP services. Just as every building today has water, canal and electricity connections, logistics connections should also exist in the future. Figure 2 compares the situation today and the future with the LogiPipe vision.

There are a lot of research activities in the fields of tube logistics and underground freight transport (UFT). The most famous is probably Hyperloop One – this system will be used for humans and goods (Bradley, 2016; Dudnikov, 2017). A similar project to LogiPipe is PipeNet

(Cotana, 2018). In evacuated tubes goods will be moved through electromagnetism very fast over long distances. Other projects are “Cargo Sous Terrain” or “CargoCap” (CST AG, 2018; CargoCap GmbH, 2018) or (Pielage, 2001). In contrast to the others LogiPipe will distribute goods only local in bigger cities. The velocity of the transport capsule is about 40 km/h. Therefore no tubes must be evacuated and many capsules can drive directly behind another.

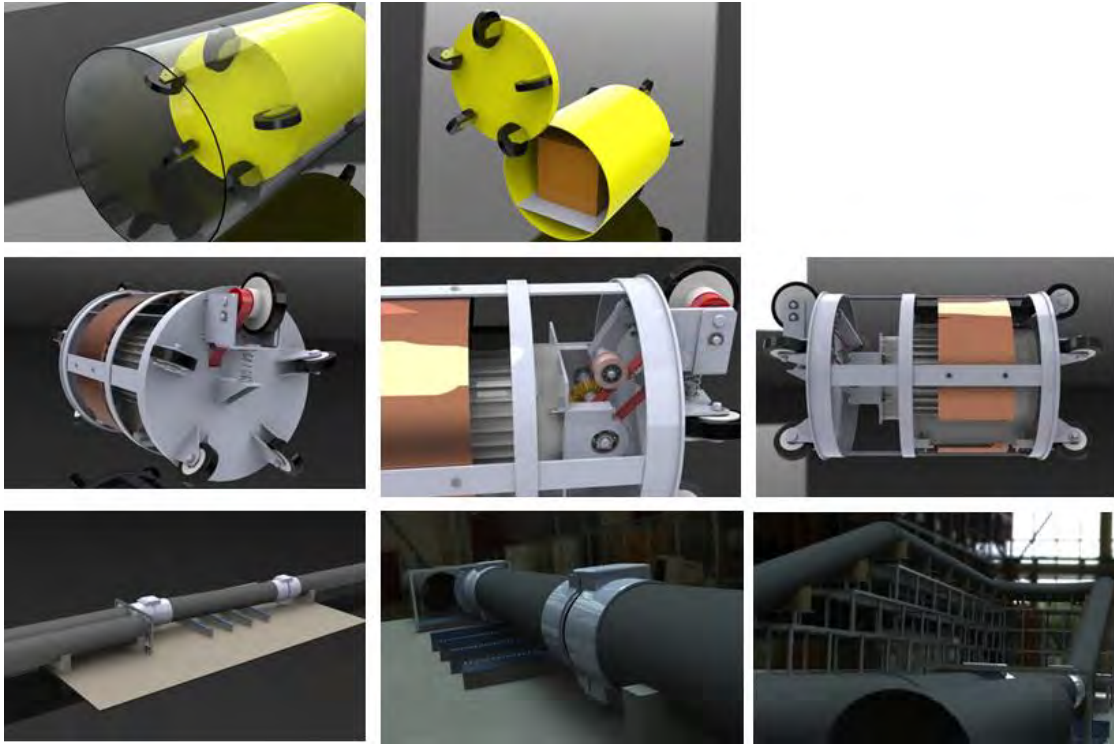

Figure 1: Components of LogiPipe (Sparber and Holzleitner, 2013)

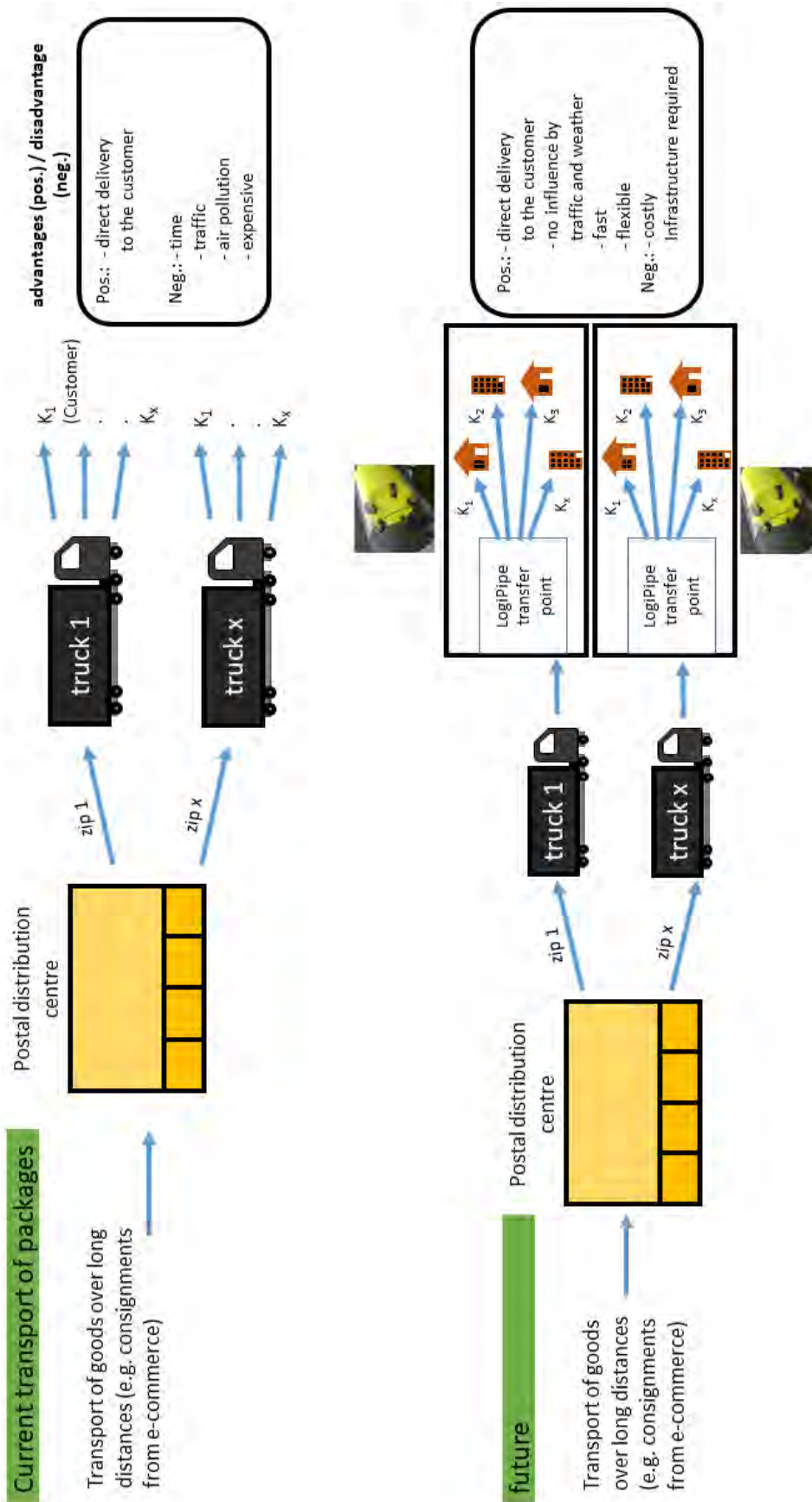

Figure 2: Comparison of the current package transport and the transport with LogiPipe

2.1 Closing the gap of the Internet's last mile

Starting points of LogiPipe are the π - hubs (see Figure 2) located on the periphery of cities (Montreuil, 2011). LogiPipe represents an extension of the Internet to inner-city areas and ensures that the Physical Internet could cover 80% of the last mile's amount of traffic. The transport capsules are designed to accommodate various sizes of modular containers (π containers), such as MODULUSHCA boxes (Landschützer et al., 2015). Depending on the number of parties in a building, a collection station is connected to the logistics connection. LogiPipe delivers the goods completely automatically, so that the recipient only has to remove them from the collection station. In an ongoing research project, we plan to investigate the system structure of LogiPipe regarding its capacities, required infrastructure, queuing theory, bottle necks and empty capsule or empty container management by conducting a simulation study.

The underground installation of LogiPipe offers a number of significant advantages. No valuable open spaces are required within the city area and, therefore, no noise emissions would reach the surface and affect people. Furthermore, the safe and rapid transport of goods would be ensured, independent of external influences such as adverse weather conditions (heavy rain, storm, black ice) and traffic jams. The intelligent electric drive would ensure a high level of energy efficiency and that no air pollutants would be produced. LogiPipe would be available 24 hours a day, 365 days a year. This would ensure the rapid and reliable delivery of goods even at times that high volumes of parcels would be expected, such as at Christmas or after Black Friday.

The last-mile requires a lot of work for CEP-services. Many difficulties are caused by circumstances that are difficult to influence (weather; traffic situation - construction sites, accidents, rush hour; are the recipients at home?). For LogiPipe all these circumstances are not relevant. The result is that countless vans will disappear from the cityscape.

2.2 An economic view of LogiPipe

As already mentioned, LogiPipe can solve the last-mile problem, which is primarily an economic problem. Figure 3 shows that the last few kilometers of the transport distance account for approx. 40% of the total transport costs. The reason for this is that the process of delivering parcels to the recipient's front door is highly labor- and time-intensive.

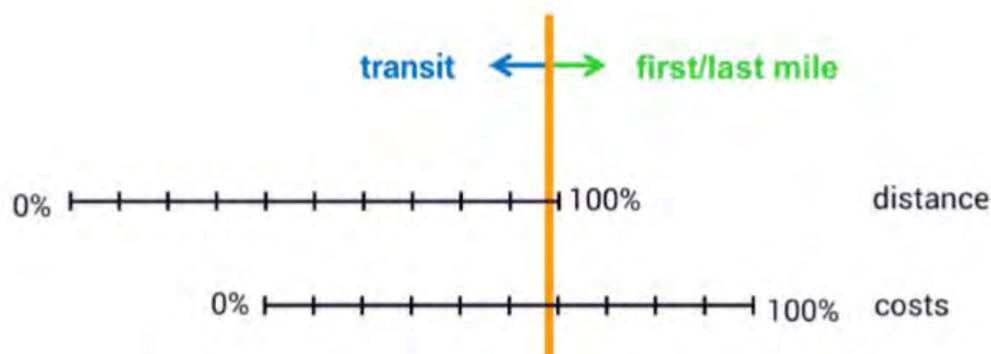

Figure 3: Costs on the last mile (Vanheusden, 2015, p. 50)

This circumstance, therefore, suggests that correspondingly high investments in this area may prove to be advantageous from an economic point of view. To determine whether LogiPipe can provide financial benefits, a cost comparison was made between delivery by traditional CEP services and delivery by LogiPipe, which can be seen in Table 1.

This cost comparison is only quantitative, as too many unknown variables are present to allow an exact calculation to be made. A daily number of 50,000 packages were chosen, which corresponds approximately to the daily average of packages delivered in a city the size of Vienna.

To determine whether LogiPipe is economically competitive in operation, a cost comparison calculation was carried out. Unfortunately, the infrastructure (how many capsules and pi-boxes, collection stations), which is required for LogiPipe cannot be estimated yet. An extensive simulation study is necessary first. However, it can be assumed that the service life of the transport capsules will be very long, because they will not be affected by external influences and will only be subject to small forces during operation. Therefore, only wear-related repairs (such as the rollers) will be necessary. Please keep in mind that LogiPipe is still a vision and therefore in an early stage of development. The following cost comparison does not claim to be complete or correct – in fact: it's a rough static calculation.

Table 1: Comparison of costs between traditional delivery and delivery via LogiPipe

Comparisons of cost between traditional delivery and delivery with LogiPipe for 50,000 packages per day				
traditional delivery			LogiPipe	
daily track length	30.000	km	elec. power/ capsule	2.000 W
outreach/ delivery van	700	km	service time/ day	16,4 h/d
fuel price	1,15	€/l	energy consumption/ capsule and day	33 kWh
fuel usage	7	l/100km	number of capsules	1.060 pcs
tank capacity	49	l	total energy/ year	12.690.320 kWh/a
fuel costs/ day	2.415	€/d	electricity rate	0,18 €/kWh
fuel costs/ year	881.475	€/a	energy costs for transport/ year	2.284.258 €/a
operational performance/ van	300.000	km	traditional delivery	1.755.895 €/a
entire stretch/ year	10.950.000	km	personnel costs - maintenance	530.000 €/a
new delivery vans/ year	37	pcs	material costs - maintenance	350.000 €/a
price/ new van	20.000	€	energy costs system	500.000 €/a
costs of new vehicles/ year	730.000	€/a		
packages/ delivery van	150	pcs	total costs/ year	4.920.153 €/a
drivers needed	320	pcs		
annual salary (gross)/ driver	22.400	€		
personnel expenses/ year	7.168.000	€/a		
total costs/ year	8.779.475	€/a	costs differential/ year	3.859.322 €/a

With traditional parcel delivery, around 30,000 km are covered daily by delivery vehicles, resulting in over EUR 880,000 in fuel costs per year. The useful life of a vehicle was assumed to be 300,000 km. This means that a new car must be purchased after traveling this distance, and the decommissioned car has a residual value of EUR 0. This results in the purchase of 37 new commercial vehicles per year at a price of EUR 730,000. Table 2 shows, however, that personnel costs of over EUR 7 million per year are a major cost factor. The Austrian average wage level was used as the basis for personnel costs.

With LogiPipe, the accrued costs result mainly from the energy consumption of the capsules and any remaining necessary conventional delivery methods. This is required for goods that are larger than the maximum package dimensions which, therefore, do not fit into the transport capsule. Empty runs were not taken into account during these calculations, but the required capacity of the capsules at maximum weight and maximum gradient plus a reserve surcharge was applied as a correction. The maintenance and system costs are estimates only and should, therefore, be treated with caution.

Even if the value of these calculations to serve as a definitive guideline is somewhat uncertain, the operation of LogiPipe offers clear advantages over the CEP services. These assumptions

result in a positive balance of more than EUR 4 million. Roughly speaking, this would mean that, if the infrastructure of LogiPipe costs EUR 40 million, these costs would be amortized after approx. 10 years.

However, operating costs are only one part of a holistic cost analysis. On the one hand, the savings from the health sector, which are difficult to quantify with any degree of accuracy, must be taken into account. On the other hand, the importance of efficient logistics, which is essential for a state and its economy and society, must be considered. The Logistics Performance Index (LPI) is a measure of the existing structure of a nation. The LPI is a key figure that is determined annually by the World Bank (World Bank, 2016) through surveys taken by experts in the field of logistics (i.e., their service providers). These experts evaluate the entire infrastructure in a country with these surveys. In addition, issues that are primarily political, such as customs procedures, are also taken into account. Germany is the absolute leader in terms of its LPI, followed by the other European countries. To maintain a country's prosperity and economic performance, therefore, it is essential to invest permanently in the logistics infrastructure, otherwise it will suffer economic losses due to losses of orders. In turn, to maintain its leading positions, a country must create new mobility systems that meet the respective requirements and use cutting-edge technology.

2.3 New business models

The authors' vision of the uses of LogiPipe, which have been described in this paper, extend even further. The possible areas of application are diverse but require the development and application of new business models.

A current trend is for local traders and shops in the city center to enter into financial difficulties due to a lack of turnover. Although people generally want to strengthen the domestic economy, the high demand for comfort is also having an impact in this area. First, it is nerve-racking to travel by car through the inner-city traffic. Second, the search for a parking space is often tedious. Third, buy an overpriced parking ticket. These factors contribute to the fact that many people prefer to order goods online and have them conveniently delivered to their homes. The speed of delivery is also becoming more and more important, especially in the case of spontaneous purchases; customers want instantaneous gratification (or as near to this as possible). Proof of this is provided by the success of Amazon Prime, whose core offer is their free express delivery. Customers who buy into Amazon Prime are promised that they can even receive their goods on the same day that they order them in many cities, simply by paying a fixed annual fee. Thanks to the ubiquitous nature of the LogiPipe structure, local retail trade could benefit greatly and continue to exist alongside the 'online giants'. Orders would still be placed online at a regional, trustworthy store, but the delivery would be made with LogiPipe. Once a functioning network has been established, delivery could potentially be guaranteed within a few minutes of the customer's placing an order. This would sustainably strengthen the domestic economy, while, at the same time, increase the buyers' comfort. The envisioned potential of LogiPipe exceeds the facts that have been described by far. In the future, for example, daily shopping, the entire postal service, or food could be delivered directly, quickly and in an environmentally friendly way from the local Italian restaurant with LogiPipe.

The investment costs for LogiPipe are undoubtedly high. The operator, who is responsible for the entire infrastructure, could be the city, a postal company or a private entrepreneur. Everyone can use the infrastructure for a fee, equal to electricity- and railway networks. What a fee schedule could look like is part of future research work.

New technologies always bring new business models with them. Similar to the Internet, these have to be developed first and are therefore part of future research activities.

3 Conclusions and outlook

The mobility of goods in urban areas will inevitably change in the near future. LogiPipe presents an interesting logistical alternative. By connecting businesses and logistics centers to the city hubs, LogiPipe can close the gap presented by the last-mile problem in a space-saving and environmentally friendly way. In this way, the surrounding area is protected from further environmental damage and people's well-being is promoted. Furthermore, emissions that are harmful to human health can be reduced and diseases can be prevented. The combination of healthy people and the necessary logistical infrastructure will help ensure the country's sustainable prosperity. Our future research on LogiPipe involves extensive simulation studies. These studies will place a focus on the structure of the network, such as how many pipes have to be laid, how many capsules are necessary for smooth operation and what the empty capsule management looks like. Subsequently, it is planned to build a first LogiPipe demonstrator to carry out applied experiments.

Acknowledgements

This work was supported by Graz University of Technology - Initial Funding Program [F-AF7-309-01].

4 REFERENCES

- ALICE (2018): *Urban Freight Research and Innovation Roadmap*. <http://www.etp-logistics.eu/>.
- Bradley, R. (2016): The unbelievable reality of the impossible hyperloop. *Technology Review* **119**, 38-47.
- CargoCap GmbH (2018): *CargoCap*. <http://www.cargocap.de/>.
- Cotana (2018): *Pipe\$net*. <http://www.pipenet.it/>.
- CST AG (2018): *Cargo sous terrain*. <http://www.cargosousterrain.ch/de/grundprinzip.html>.
- Dudnikov, E.E. (2017): Advantages of a new Hyperloop transport technology. In, *Proceedings of 2017 10th International Conference Management of Large-Scale System Development, MLS D 2017*.
- Etezadzadeh, C. (2015): *Smart City - Stadt der Zukunft?* Berlin: Springer.
- European Environment Agency (2016): *Towards clean and smart mobility: Transport and environment in Europe*. Copenhagen: Publications Office of the European Union.
- Landschützer, C., Ehrentraut, F., and Jodin, D. (2015): Containers for the Physical Internet: Requirements and engineering design related to FMCG logistics. *Logistics Research* **8**.
- Montreuil, B. (2011): Toward a physical internet: Meeting the global logistics sustainability grand challenge. *Logistics Research* **3**, 71-87.
- OECD (2017): *ITF Transport Outlook 2017*. Paris: OECD publications.

- Pielage, B.J. (2001): Underground freight transportation. A new development for automated freight transportation systems in the Netherlands. *IEEE Conference on Intelligent Transportation Systems, Proceedings, ITSC*, 762-767.
- Schrampf, J., Zvokelj, A., & Hartmann, G. (2013): *Smart Urban Logistics: Effizienter Güterverkehr in Ballungszentren*. Wien. <http://www.smartcities.at/assets/01-Foerderungen/SmartUrbanLogistics-Gesamtkonzept-v1-0-Web.pdf>: Klima- und Energiefonds.
- Science for Environment Policy (2016): *Links between noise and air pollution and socioeconomic status*. http://ec.europa.eu/environment/integration/research/newsalert/pdf/air_noise_pollution_socio_economic_status_links_IR13_en.pdf.
- Sparber, D., & Holzleitner, K. (2013): *Automatisierte Cargo-Systeme: Von der Rohrpost zur Paketzustellung der Zukunft- Eine Konzeptstudie*. Bachelor's Thesis. TU GRAZ, Institute of Logistics Engineering.
- Statista (2017): *mobile-share-of-e-commerce-spending*. <https://www.statista.com/chart/12325/mobile-share-of-e-commerce-spending>.
- TZ (2017): *Long Waiting Times*. <https://www.tz.de/muenchen/stadt/irre-schlangen-aerger-um-lange-wartezeiten-bei-post-in-muenchen-9162636.html>.
- Vanheusden, K. (2015): *The Future of Last Mile Logistics*; ed. LaMiLo Project Final Conference. Brussels.
- World Bank (2016): *The Logistics Performance Index*. <https://lpi.worldbank.org/>.

Smart Locker Based Access Hub Network Capacity Deployment in Hyperconnected Parcel Logistics

Louis Faugère^{1,2,5}, Satya S. Malladi⁵, Benoit Montreuil^{1,2,3,5}, Chelsea C. White III^{2,4,5}

1. Physical Internet Center

2. Supply Chain and Logistics Institute,

3. Coca-Cola Chair in Material Handling & Distribution

4. Schneider National Chair in Transportation and Logistics

5. H. Milton Stewart School of Industrial & Systems Engineering

Georgia Institute of Technology, Atlanta, USA

Corresponding author: louis.faugere@gatech.edu

Abstract: This paper deals with the dynamic deployment of modular smart lockers in the context of first and last mile delivery in Physical Internet oriented hyperconnected parcel logistics systems. Its main contribution is the conceptualization of a decision framework enabling to benefit from the advantages of distributed logistics systems while limiting capital expenditures. The paper first synthesizes insights from the current literature. It then defines a conceptual framework enabling the dynamic deployment of locker module capacity and depicts the induced design and operational challenges, highlighting the potential benefits and trade-offs through an illustrative case. Finally, it provides directions for future research and innovation.

Keywords: Smart Lockers, Dynamic Capacity Deployment, Capacity Relocation, First and Last Mile Logistics, Parcel Logistics, Physical Internet.

1. Introduction

In omnichannel supply chains, buffer storage capacity such as distributed fulfillment centers, click-and-collect drives, stores and smart lockers enables the positioning of physical goods closer to demand and supply points, thus creating opportunities for faster, more flexible and more cost-effective logistics services (Morganti et al., 2014; Savelsbergh and Van Woensel, 2016; Montreuil, 2017). Montreuil et al. (2018) introduced access hubs as the first network of a multi-level logistics web designed to achieve cost effectiveness while enabling tight urban service offerings in the parcel logistics industry. Figure 1 depicts such parcel logistics web in which access hubs are the closest facilities to the demand (i.e. pickup and delivery locations).

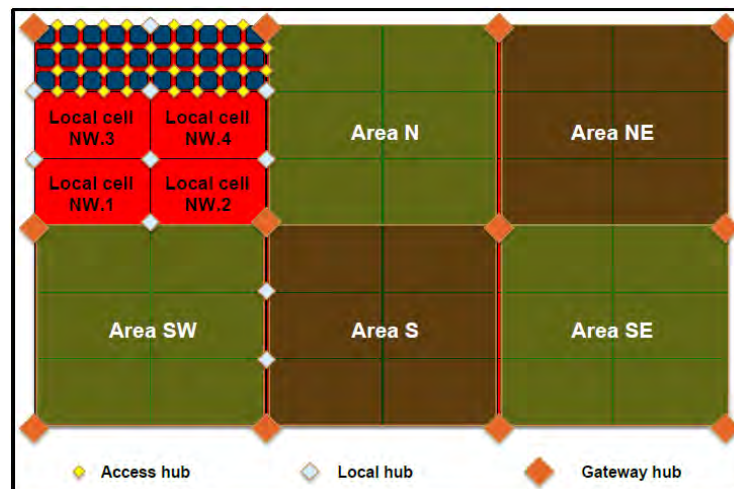

Figure 1: Parcel logistics web. Source: Montreuil et al. (2018)

Getting closer to demand and supply locations requires the deployment of a distributed network of logistics assets that can represent significant capital expenditures. Dynamic capacity deployment has the potential to mitigate the disadvantages of static distributed assets deployment while benefiting from its valuable advantages for facing today's logistics challenges. Typically, when the distributed nodes have sole responsibility for serving sub-territories within the overall market territory, more capacity is needed in the distributed inventory system than in a centralized inventory system to achieve the same customer service level. When dynamically deploying access hub network capacity, we aim at limiting the cost induced by such distributed logistics system while maintaining a customer service level.

There are several ways to embed access hub capacity for omnichannel logistics, from simple package rooms to automated storage and retrieval units. In this paper, we focus on pickup-and-delivery smart locker systems. Such locker systems offer temporary storage locations, typically for parcels, close to customer locations (housing units, offices, public transportation stations, etc.). In the case of parcel delivery, we identify two ways of operating such systems: (1) using smart lockers as an intermediary between logistics providers and consumers and (2) using smart lockers as a temporary storage location for logistics providers to distribute parcels close to consumers while waiting for the most convenient time to perform deliveries. Similarly, in the case of parcel pickup, smart lockers can be used as (1) intermediary between consumers and logistics carriers – consignment points – or (2) temporary storage locations for logistics providers to hold on to packages and create opportunities for consolidation before relocating them to a higher-level sorting facility. Hereafter, types (1) and (2) will respectively correspond to *customer* and *logistic* lockers or locker banks.

Depending on their intended use, smart lockers can have different design structures, mostly constrained by the fact that customers who use smart lockers need separate storage bins for each individual parcel for privacy and security reasons. Figure 2 (left) shows a current example of customer locker bank. For logistic locker banks, solely used by agents of logistics providers, it becomes possible to put multiple parcels together in the same bin and privacy considerations become less important for operators (but not for the overall public). Figure 2 (right) shows a possible design for such logistic lockers developed by Georgia Tech's Physical Internet Center.

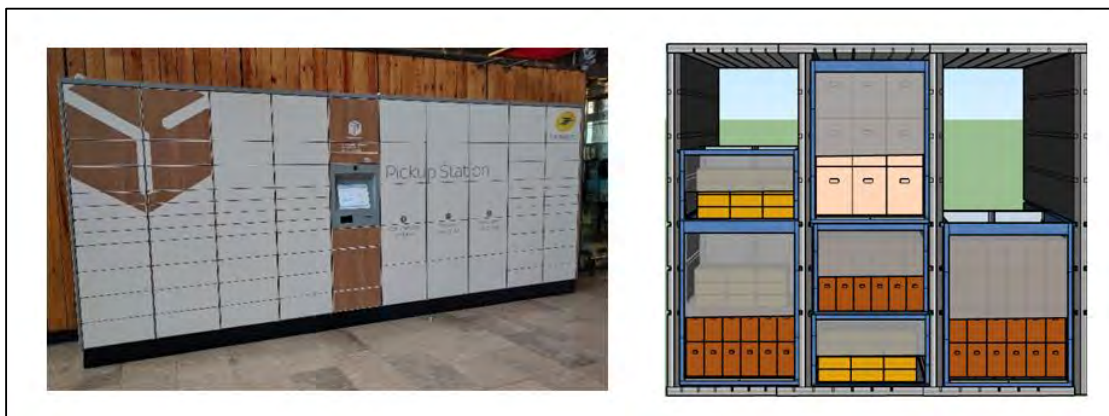

Figure 2: Example of Customer Locker (left) and Logistic locker (right).

Sources: photograph from authors (left), design by the Physical Internet Center (right)

Faugère and Montreuil (2017; 2018) have proposed modular smart locker designs, notably using Physical Internet concepts. In their design, smart locker banks are conceived as a concatenation of modular towers, or locker modules, plugged to each other. The authors envisioned using such modularity to adjust the capacity of smart locker banks over time, potentially rebalancing modular tower capacity within a network.

In this paper we consider the context where a network of smart logistic locker banks is implemented in a territory (e.g. a megacity) and we investigate the potential for exploiting locker bank modularity and adding, moving and removing locker modules to dynamically adapt buffer storage capacity in distributed zones across the territory. We contrast such mobile logistic locker network to a rigid logistic locker network not exploiting the modular mobility capability of locker banks.

Innovations in the manufacturing industry have motivated the study of mobile modular production and storage. Marcotte and Montreuil (2016) have presented various threads of innovation, such as distributed production, on-demand production, additive production, and mobile production, that motivate and would benefit from hyperconnected mobile production and set the stage for potential next steps of research. Marcotte et al. (2015) introduced mathematical models for optimizing production and storage decisions as well as mobile production and storage module relocation decisions in mobile make-to-stock and make-to-order production systems under deterministic demand. Malladi et al. (2018a) present a dynamic programming model to manage a multi-location mobile production and inventory system facing stochastic, stationary demands and propose well-performing heuristic approaches that help establish the value of mobile production over in-ground production. This framework is generalized by Malladi et al. (2018a; 2018b) to allow the additional option of inventory relocation between locations and to capture non-stationary Markov-modulated demands with a partially observed modulation process.

Relocating production, inventory and buffer storage capacity over a network also hints to closing and opening locations. Jena et al. (2015) studied such dynamic facility location problems where not only sites could be permanently or temporarily opened and closed, but also resized by adding or removing modular capacity. However, these capacity adjustments were considered independent location-wise; that is, capacity is not moved from a location to another, but rather bought or sold from/to suppliers. Melo et al. (2005) proposed models capturing modular capacity shifts from existing to new locations. That is, limiting existing locations to decrease their capacity by moving modular capacity to new locations. Here, we are interested in modular capacity shifts within a network of existing locations without such restrictions.

As it is established in the manufacturing-focused literature that there is advantage in moving production and storage capacity as well as inventory, there is reason to believe that sharing limited resources in a spatiotemporal fashion across locations in a logistics network is to yield savings under some conditions. In this paper we report a preliminary analysis with deterministic demand and we observe significant savings from exploiting a mobile locker network over a rigid locker system as well as significant reduction of overall deployed capacity. The results show that smart locker mobility and consequent sharing of logistic locker modules enable investing in less overall capacity. Although the system appears to be decentralized across multiple locations, the thread of sharing locker modules would reconnect and/or centralize the multi-site decision-making, enabling risk pooling. This unique problem setting is challenging due to the curse of dimensionality associated to an exponentially large state space, and the many design questions that must be answered prior to operation. It can subsequently be extended to spatiotemporal demand uncertainty adding another challenging dimension.

2. Problem definition

We address the deployment of locker module capacity over a network of access hubs implemented as smart logistic locker banks. Locker module capacity aims at offering temporary storage for parcels being picked up/delivered. Demand for locker modules is

therefore a secondary level of demand originating from demand for parcel pickup/delivery. Consider a set of logistic locker banks (acting as access hubs) N with non-stationary modular periodic demand for locker modules. We model a set of depots O where locker modules can be stored at a cheaper cost than at a logistic locker bank site when not in use, and a set of suppliers S , from which new modules can be acquired. The option of acquiring new modules from suppliers becomes essential when the global demand grows along with global capacity requirements. The problem is then to define a locker module deployment strategy that satisfies periodic requirements and minimizes the costs induced by capital expenditures and relocations between logistic locker banks N , and depots O .

3. Conceptual framework

In this section, we present a conceptual framework enabling to create smart logistic locker based access hub network capacity deployment strategies and identify and discuss potential challenges.

3.1. Decision framework

To enable dynamic deployment of locker module capacity, we propose a cyclic decision framework, depicted in Figure 3. It is composed of four stages: observation, forecasting, planning, and implementation. Each of these stages can be influenced by external factors (e.g. macroeconomic trends, consumer behavior) and internal policies (e.g. firm's strategy, operational policies, staffing).

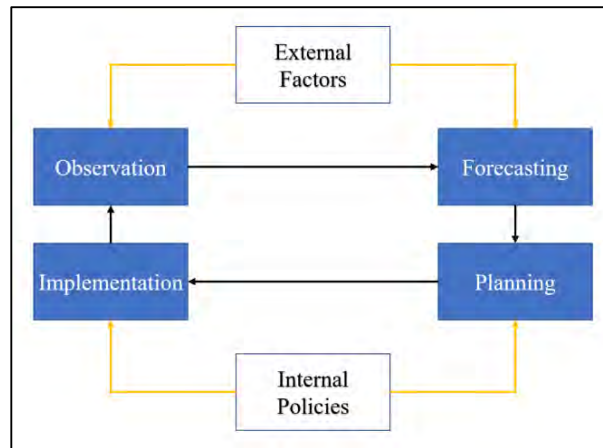

Figure 3: Cyclic Decision Framework for Dynamic Capacity Deployment

We hereafter highlight the essence of each stage:

- Observation is mainly about dynamically collecting demand history and external factors.
- Forecasting is about using observed data and external factors to forecast future demand. When dealing with large networks at high pace, it is mandatory to do so using automated methods (e.g. smoothing methods, machine learning).
- Planning is about generating and describing a feasible plan of action to deploy locker module capacity over the period for which demand has been forecasted, over the network of access hub locations.
- Implementation is about enacting the plan of action in the system.

The length of this cycle will impact the resource requirements as well as the potential savings. Short cycle length has the potential to offer more savings, by more closely monitoring and

forecasting demand and by frequently updating the plan. However, shorter cycles may require more granular data collection, and adaptive planning and execution. Longer cycle length may be less resource-intensive but may enable less savings due to prolonged decision-making based on a one-time demand forecast. This inherent tradeoff enriches the scope of the framework.

3.2. Challenges

In this section, we identify challenges of defining dynamic network capacity deployment strategies and propose potential ways to address them.

3.2.1. Size of the problem

A typical asymmetric complete network of n nodes is composed of $n(n - 1)$ arcs. Thus, when managing n access hub locations, there are n^2 decisions to take each time we consider adjusting the distribution of capacity; one needs to decide what is the capacity required at each location (n), and how to move mobile capacity throughout the network ($n(n - 1)$). Even for reasonably small cases, the size of the decisional space can be significant, which can be a challenge in terms of computing power and memory requirements. Solving the problem can quickly become intractable as case size grows, especially when attempting to find solutions using commercial solvers.

To reduce the size of the problem and simplify operational challenges, we propose to explore the impact of *limiting actions*, i.e. limiting the number of arcs of the network. Figure 4 illustrates graph reduction from a complete graph to a smaller incomplete graph with a smaller number of decision variables. Operationally, this strategy is potentially simpler to implement as it limits the number of potential relocations per location. An intuitive way to think about graph reduction is to limit the distance between pairs of locations for which a module exchange is to be considered.

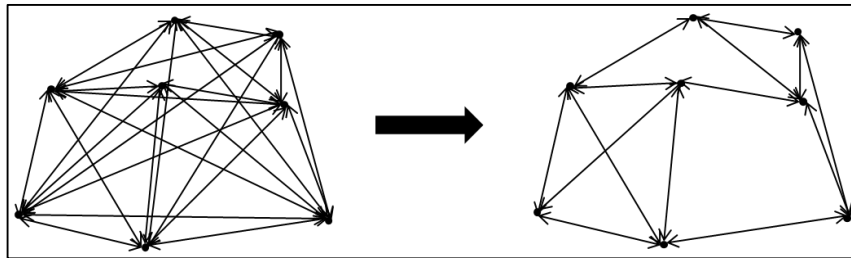

Figure 4: Illustration of limitation of actions (pairing)

Limiting actions by distance may dramatically impact the potential savings if demand trends are local. If locations that are close to each other have similar demand patterns, then limiting exchanges to nearby locations will lock away high potential solutions exchanging locker modules between locations that are further away yet have counterbalancing needs. Learning about the geographical distribution of demand patterns can help identify pairs that have a higher savings potential. For example, location pairs with negative statistical correlation will be better candidates than location pairs with correlations close to one. Figure 5 illustrates what demand (in terms of capacity requirements) might look like for a higher-potential candidate pair, i.e. with asynchronous demand patterns, and a lower-potential candidate pair.

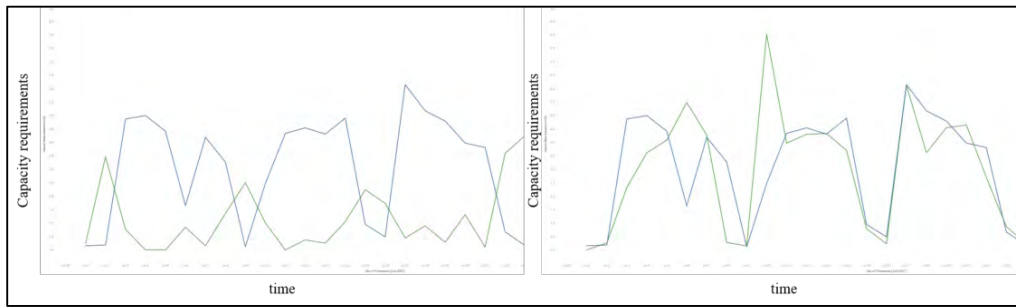

Figure 5: Comparative capacity requirements over time of higher-potential (left) and lower-potential (right) candidate pairs

3.2.2. Design and operational complexity

When implementing a solution found in the planning phase, design and operational challenges arise. For instance, the frequency at which capacity adjustments are being made impacts the design of locker modules as well as the design and training of resources for moving (equipment and workforce). Indeed, if adjustments are being made at the end of each business day (before the next day), locker modules must be both convenient and fast to install and transport, while also being robust. And, the design of the modules themselves will impact the moving resources as they may require special handling equipment. Conversely, if adjustments are being made bi-annually and can thus be implemented over a longer period (e.g. a week), designs harder to install/move could be considered, potentially reducing the cost of each module and the complexity of moving resources. It is thus important to find a balance between frequency of adjustment and complexity of system design, which impact potential savings and induced costs.

If no restrictions are made on the location pairs of potential relocation arcs, solutions may be very different cycle after cycle, requiring very flexible teams with large scope of action, for example in terms of geographic coverage. Such resources can be expensive and more subject to making errors, for example resulting in damaging equipment or failing to find a location. It can be advantageous to limit the scope of action by having local teams with local knowledge, who will better know their area. Again, it is important to find a balance between scope of action and operational simplicity.

An intuitive idea to simplify operational challenges is to explore the impact of *limiting scope*, i.e. taking multiple local decisions rather than a global decision. Clustering the network in areas that are managed in a decentralized fashion enables the distribution of the decision-making process and the simplification of operations by having local teams with local knowledge responsible for managing their own areas. It becomes more intuitive when considering megacities covered by thousands of access hubs, difficult to manage at once. Figure 1 illustrates the concept of limitation of scope by natural clustering on a generic megacity structure. It depicts two levels of access hub clusters: local cells and urban areas. One may consider managing access hub capacity of a local cell/area separately from the entire network, using surrounding local hubs/gateway hubs to eventually exchange locker modules with neighboring local cells/areas, or store unused locker modules. The decision-making process could thus be broken down in two steps: a set of local capacity deployment decisions, and a global inventory balance decision.

3.2.3. Data requirements and methods

Quality of data and methods used in the decision framework is critical to achieving significant savings while implementing such strategy. First, as with any data-driven decision process, data collection can be a challenging task. It may require additional resources as well as more

complex data structures in order to ensure quality as well as privacy. This becomes especially true when managing multi-party systems where stakeholders might be competitors and thus require careful control over operational data.

Second, even when perfect data is collected, the quality of methods leveraged will eventually define the gap of the solution from the optimal. The forecasting methods used to estimate what demand will be over the planning horizon are a first bound to optimality, as perfect forecasting is virtually impossible. The methods employed to find solutions to the planning problem are also subject to simplification and uncertainty. In part 3.2.1, the size of the problem was identified to be potentially challenging in terms of computational power. It will impact the type of methods that are reasonable to leverage, which have their own pros and cons.

4. Preliminary results

In this section, we perform a set of experiments on a simple version of the problem to assess the potential savings offered by dynamically deploying locker module capacity. In this version, to solely explore the potential of relocating capacity, we will not consider having a depot to store unused capacity, and we will acquire all the capacity required for the entire horizon in the first period. The underlying demand data used is extrapolated from trends observed working with a major logistics carrier in the courier, parcel and express industry.

4.1. Problem setting

The objective is to assess the potential savings offered by dynamically deploying locker module capacity over a network of modular pickup-and-delivery logistic locker banks. We consider a set of $N = 25$ access hub locations with modular capacity requirements, over a planning horizon of $T = 30$ consecutive periods of two months. In the preliminary study, we assume that modules cannot be periodically acquired from suppliers; thus, the overall capacity of the network is constant over the entire planning horizon.

4.2. Optimization model

The following simple mathematical model is used for finding optimal solutions.

Mathematical sets and graph:

T planning horizon (periods)

N set of access hub locations

$G = (N, A)$ is a complete symmetric graph satisfying triangle inequality

$\delta^-(i), \delta^+(i)$ sets of all incoming and outgoing relocation arcs of location i

Indices:

t period, $t \in T$

i access hub locations, $i \in N$

a relocation arc between two locations $i, j \in N, a \in A$

Parameters:

c_a^t cost of relocating one locker module on a at the beginning of period t . This includes (dis)assembling, handling and transportation costs

h_i^t cost of having a locker module at location i in period t . It includes amortized acquisition cost and can include a real-estate rental component, as well as operating costs (energy, insurance, ...)

Decision variables:

X_a^t number of locker modules moved on arc a at the beginning of period t

S_i^t number of locker modules available in location i for period t

Model:

$$\min \sum_{t=1}^T \left\{ \sum_{i \in N \cup \{0\}} h_i^t S_i^t + \sum_{a \in A} c_a^t X_a^t \right\}$$

$$\text{s.t.} \quad \sum_{a \in \delta^-(i)} X_a^t + S_i^t - \sum_{a \in \delta^+(i)} X_a^t = S_i^{t+1} \quad \forall i \in N \cup \{0\}, t = 1, \dots, T-1 \quad (1)$$

$$S_i^t \geq d_i^t \quad \forall i \in N \cup \{0\}, t = 1, \dots, T \quad (2)$$

$$X_a^t, S_i^t \text{ integer} \quad (3)$$

Sets $\delta^-(i)$ and $\delta^+(i)$ are formally defined as follows:

$$\delta^-(i) = \{a = (k, i) : k \in N\}$$

$$\delta^+(i) = \{a = (i, k) : k \in N\}$$

The objective is to minimize the costs induced by deploying locker modules over the network, and by relocating locker modules between locations. Constraints 1 represent the locker module inventory balance at each location. Constraints 2 ensure that the number of locker modules at each location meet the respective demand d_i^t for each period $t \in [1, T]$.

In all the following experiments, the optimization model was programmed with Python and the package gurobipy, solved with the commercial solver Gurobi 7 on a laptop computer with processor Intel® Core™ i7-6500U and 8GB or RAM.

4.3. Experiment

The following experiments aim at assessing the relevance of the concepts proposed in section 3, as well as at identifying insights and avenues for future research. They are performed on a demand data set representative of a real-world industry case, provided in Appendix A.

The cost parameters are defined as follows:

- The relocation costs include an operational cost of \$1.50 per kilometer that includes vehicle cost and operator movement cost, and a fixed cost of two operators hired for two hours at a rate of \$10 dollars per hour to uninstall/install modules once at the locations:

$$c_a^t = \text{dist}(i, j) * \$1.50 + 2 \text{ operators} * 2 \text{ hours} * \$10/\text{hour}, \forall a = (i, j) \in A, t = 1, \dots, T$$

Where $\text{dist}(i, j)$ is the distance in kilometers between locations i and j .

- The holding costs are computed from an amortized acquisition cost of \$2000 over 5 years inspired from Faugere and Montreuil (2018):

$h_i^t = \frac{\$2000}{30 \text{ periods}} * (1 + r_i), \forall i \in N \cup \{0\}, t = 1, \dots, T$ where r_i is generated randomly following a uniform distribution between 2% and 15% to represent the variation of real-estate, insurance and operations costs over the locations of the network.

4.3.1. Initial solution

First, we are interested in assessing the potential capacity and cost savings offered by allowing to dynamically adjust the network over time. In the rigid logistic locker network case where relocations are not allowed between locations, the minimal total number of locker modules needed to meet the demand d^t for all periods is upper bounded by $\sum_{i \in N} \max_{t \in [1, T]} d_i^t = 405$ modules at a cost of $\sum_{i \in N} h_i^t \max_{t \in [1, T]} d_i^t = 889$ K\$ (thousands of dollars) over the planning horizon, and an average utilization rate (ratio demand over modules deployed in each period) of 56%. In the mobile logistic locker network case allowing relocations, the minimum number of modules needed to meet demand is lower bounded by $\max_{t \in \{1, T\}} \sum_i d_i^t = 298$. Therefore, the maximum capacity savings that we can expect in number of locker modules is $\frac{405-298}{405} = 26.42\%$.

When solving the model presented in section 4.2, we obtain an optimal solution deploying a total of 298 locker modules, at a cost of 674 K\$. It represents 26.42% capacity savings and 24.18% cost savings, for a utilization rate of 78% in average. In the solution, 438 relocations of locker modules occurred over the 30-period horizon. Figure 6 depicts the module relocation network for the optimal solution, where each node is an access hub and each arc corresponds to at least one relocation of a module from a hub to another hub at some period. Arc width is proportional to the number of transfers over the planning horizon.

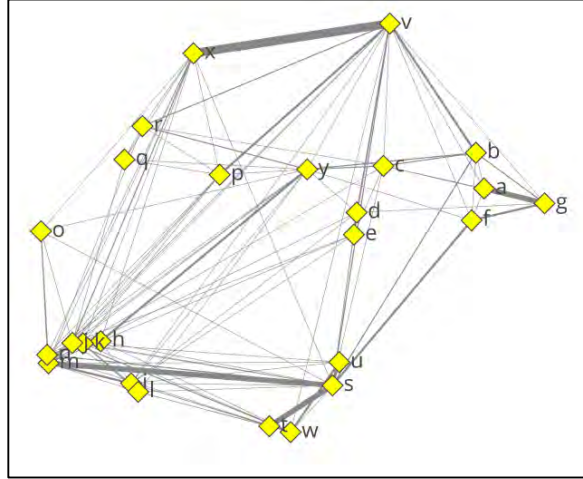

Figure 6: Illustration of the initial solution on the network of interest

4.3.2. Limitation of actions by correlation

In section 3.2.1, we proposed a way to reduce the size of the considered network by limiting the number of actions (arcs) by leveraging demand correlation between pairs of locations. Two negatively correlated locations are likely to have opposite demand patterns; thus, we can expect to find opportunities to reduce the total locker module capacity requirements by relocating modules from one location to the other as demand evolves. Following this logic, the most negatively correlated pairs would be the best candidates to exchanging modules. In this experiment, we rank such location pairs (from most negatively correlated to most positively correlated) and build our set of arcs A by selecting the top $\alpha\%$ pairs. We then solve

the model proposed in section 4.2 for different correlation thresholds $\alpha\%$, and record the overall cost of the solution and the capacity savings. Figure 7 depicts the module relocation network for optimal solutions with selected correlation thresholds $\alpha\%$.

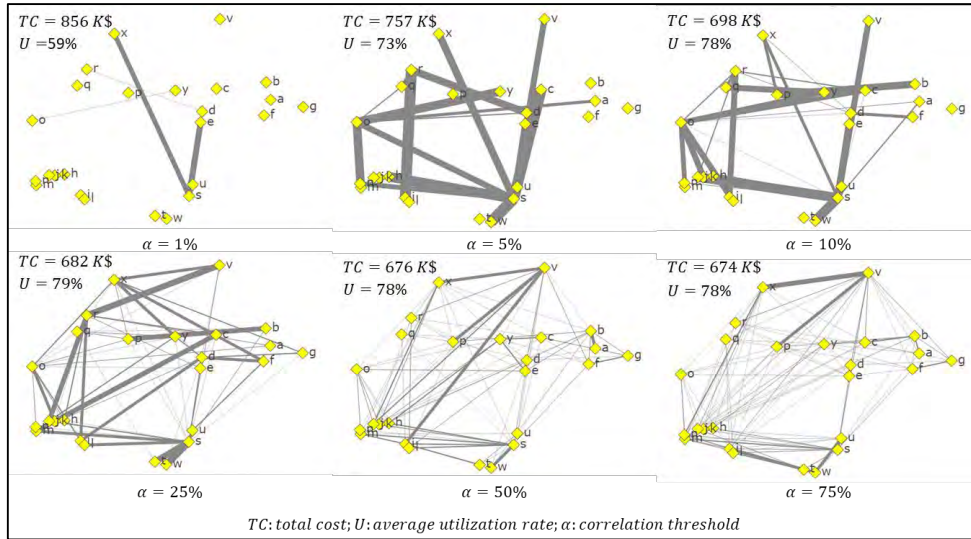

Figure 7: Illustration of the solutions on the network of interest for selected correlation thresholds

Figure 8 presents the cost and capacity savings of the solutions obtained for different correlation thresholds α .

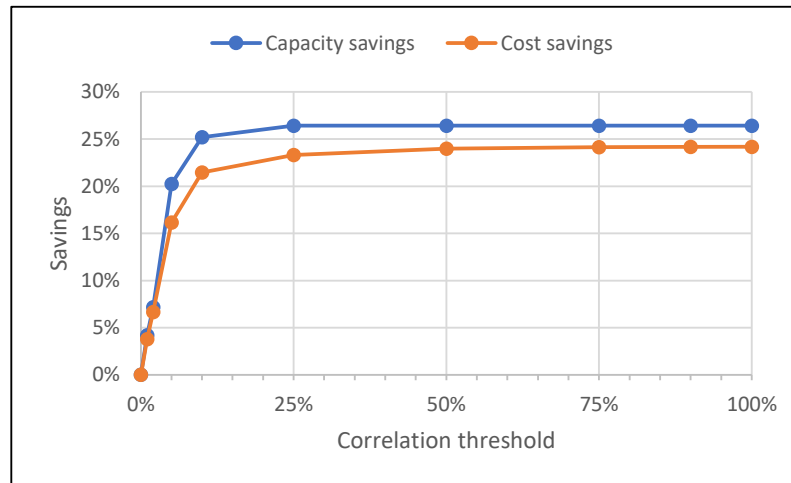

Figure 8: potential capacity and cost savings for different correlation thresholds

We can observe that full potential capacity savings are already reached for a correlation threshold of 25%, at a cost of 0.65% far from the full potential cost savings from section 4.3.1. This means that in this case, only 25% of the complete network’s arcs are needed to fully benefit from capacity savings and almost fully from cost savings (with a difference inferior then 1%). This is an encouraging result as it suggests that making the effort of evaluating and identifying candidate arcs can dramatically reduce the size of the network, making the problem potentially easier to solve.

4.3.3. Relocation cost versus holding cost

In this section we explore the impact of the cost of relocating locker modules from one access hub location to another. This cost is not to be negligible compared to the holding costs. In fact, if the cost of relocating a unit of capacity between locations is very high compared to the

holding cost, there is no reason to even consider dynamically adjusting capacity. For example, this is the case of traditional facility network design, where the cost of adjusting one location's capacity is by design too expensive to consider; each facility is designed to meet maximum capacity requirements. In this experiment, we explore the impact of the average ratio relocation cost to holding cost. With the parameters introduced for section 4.3.1 and 4.3.2, this ratio, say $c/h = 72\%$. Here, we introduce a constant factor k such that the new relocation cost is defined as:

$$\tilde{c}_a^t = k * c_a^t, \forall a \in A, t = 1, \dots, T$$

Then, we solve the model presented in section 4.2 for different values of k in order to get average ratio relocation cost to holding cost $c/h = k * \tilde{c}/h \in [50\%; 5000\%]$.

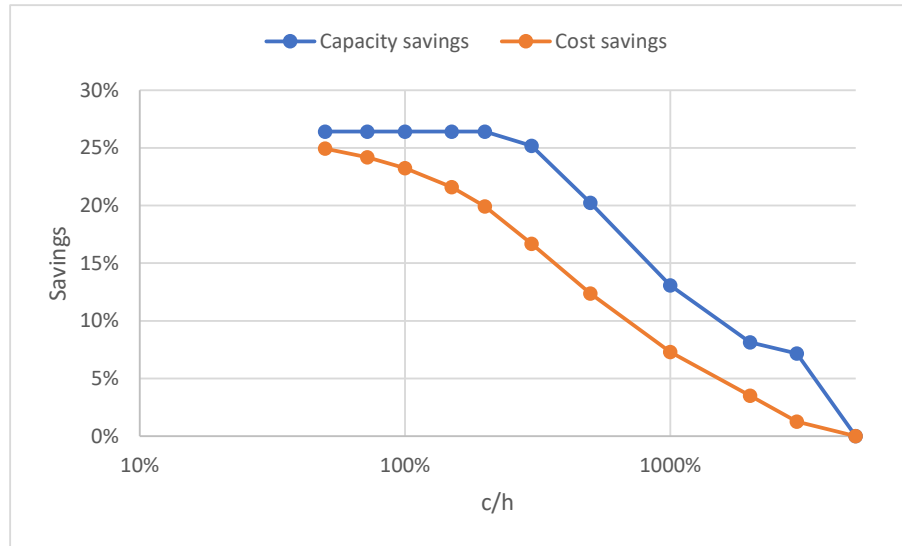

Figure 9: capacity savings in function of the relocation to holding cost ratio

Figure 9 presents results for $c/h \in [50\%, 5000\%]$. We observe that although capacity savings seem to allow larger average ratio relocation cost to holding cost before decreasing, cost savings drop dramatically as the ratio grows. Nonetheless, any ratio smaller than 5000% offers savings. This experiment emphasizes the importance of the modular design characteristics: dynamically deploying capacity over a network seem to be worth it only when the cost of relocating modules between two locations is relatively low compared to holding costs. Relocation costs are highly dependent on modular designs of the locker modules as some may require special equipment, special training and significant time to be moved while other may be as easy to move as a shelf unit.

Conclusion

The paper first synthesizes insights from the current literature. It then defines a conceptual framework enabling the dynamic deployment of smart locker based access hub capacity and depicts the induced design and operational challenges, highlighting the potential benefits and trade-offs through an illustrative case. Finally, it provides directions for future research and innovation.

This paper contributes to the development of first and last mile solutions in the context of omnichannel supply chains by proposing a conceptual decision framework for dynamic capacity deployment, enabling to decrease the total capacity requirements and increase

resource utilization. It provides promising preliminary results on a realistic case scenario, showing potential cost savings of 24% and capacity savings up to 26%, with an average utilization increase of 22%. We expect savings to be even greater when allowing locker module acquisition throughout the horizon, and allowing module rental thus defining the capacity in module-periods.

Overall, the following challenges need to be addressed when deploying a framework to dynamically deploy mobile buffer storage capacity:

- Size of the problem: the combinatorial size of the network can become a computational challenge when trying to find solutions to the problem. Preliminary results suggest that limitation of actions by correlation is a promising method to reduce the size of the problem while preserving potential capacity savings. In this study, full potential savings were almost reached when only considering 25% of the network's arcs.
- Design and operational complexity: the modularity designs, the number of locations managed and the frequency at which capacity adjustments are considered have a trade-off relationship with design and operational complexity of such system. Preliminary results suggest that potential savings are highly dependent on the ratio relocation cost to holding cost. Limitation of scope by clustering locations into subsets can be a solution to finding an optimal trade-off but needs to be deeply explored to fully understand the relationship between complexity and potential savings.
- Data requirements and methods: as with any data-driven system, the quality of data collected is critical to the system's performance; identifying and collecting data can become a challenge when dealing with multi-party operated systems impacted by external factors. Moreover, the methods used when making use of the data (forecasting, optimization) must be deeply explored to be able to provide good quality solutions at a reasonable cost.

The above challenges induce a set of research opportunities. Some of these focus on the decoupling of pickup/delivery demand and access hub capacity requirements, especially on methods to link both. Some focus on the choice of the network to consider, aligning operational and strategic strategies. There is also a need for extending research on business model and data-sharing policies for multi-party systems. Finally, there is a need for developing methods and policies to efficiently forecast and plan the dynamic deployment of locker module capacity over access hub networks.

References

- Faugère, L., & Montreuil, B. (2017). Hyperconnected Pickup and delivery Locker Networks. *International Physical Internet Conference*. Graz, Austria.
- Faugère, L., & Montreuil, B. (2018). Smart Locker Bank Design Optimization for Urban Omnichannel Logistics. *Submitted to Computers and Industrial Engineering*.
- Jena, S. D., Cordeau, J.-F., & Gendron, B. (2015). Dynamic Facility Location with Generalized Modular Capacities. *Transportation Science*, 49(3), 484-499. <https://doi.org/10.1287/trsc.2014.0575>
- Malladi, S. S., Erera, A. L., & White III, C. C. (2018a). A Dynamic Mobile Production Capacity and Inventory Logistics Problem. *To be submitted*.
- Malladi, S. S., Erera, A. L., & White III, C. C. (2018b). Data-Driven Control of Distributed Reconfigurable Production-Inventory Systems. *To be submitted*.

- Marcotte, S., & Montreuil, B. (2016). Introducing the Concept of Hyperconnected Mobile Production. *Progress in Material Handling Research*.
- Marcotte, S., Montreuil, B., & Coelho, L. C. (2015). Modeling of Physical Internet Enabled Hyperconnected Modular Production. *Proceedings of 2nd Physical Internet Conference, 2015*.
- Melo, M., Nickel, S., & Saldanha da Gama, F. (2005). Dynamic Multi-commodity Capacitated Facility Location: a Mathematical Modeling Framework for Strategic Supply Chain Planning. *Computers & Operations Research*, 33, 181-208. <https://doi.org/10.1016/j.cor.2004.07.005>
- Montreuil B. (2017). Omnichannel Business-to-Consumer Logistics and Supply Chains: Towards Hyperconnected Networks and Facilities, *Progress in Material Handling Research Vol. 14*, Ed. K. Ellis et al., MHI, Charlotte, NC, USA.
- Montreuil, B., Buckley, S., Faugère, L., Khir, R., Derhami, S. (2018). Urban Parcel Logistics Hub and Network Design: The Impact of Modularity and Hyperconnectivity. *Progress in Material Handling Research, Savannah, GA, MHI*.
- Morganti, E., Seidel, S., Blanquart, C., & Dablanc, L. (2014). The Impact of E-commerce on Final Deliveries: Alternative Parcel Delivery Services in France and Germany. *Transportation Research Procedia*(4), 178-190.
- Savelsbergh, M., & Van Woensel, T. (2016). City Logistics: Challenges and Opportunities. *Supply Chain & Logistics Institute*.

Appendix A

Table 1: locker module demand for access hub locations (part a)

Location	t=1	t=2	t=3	t=4	t=5	t=6	t=7	t=8	t=9	t=10	t=11	t=12	t=13	t=14	t=15
a	1	3	0	14	15	15	14	9	5	17	11	17	16	18	14
b	1	10	7	5	5	9	11	8	7	9	10	6	9	8	11
c	2	4	3	8	5	9	5	7	4	6	4	5	9	7	9
d	1	3	4	5	5	1	6	2	2	3	2	5	4	2	6
e	1	4	15	13	16	13	12	14	4	12	14	11	11	17	13
f	1	10	11	14	10	4	5	8	10	16	16	14	12	16	9
g	2	4	9	9	9	10	7	13	4	8	3	13	9	8	7
h	2	6	20	22	30	30	26	18	6	26	25	27	31	29	23
i	3	4	10	14	18	14	16	18	8	13	19	14	19	8	16
j	2	3	16	19	23	19	19	16	5	20	21	25	23	15	19
k	2	3	8	10	10	11	9	9	3	10	12	14	11	13	8
l	2	8	14	16	23	19	22	16	12	18	17	14	17	12	14
m	2	5	16	8	23	14	6	22	5	23	17	24	8	23	8
n	1	3	3	8	7	8	8	6	4	6	9	9	7	8	8
o	0	2	3	2	1	1	1	1	2	1	2	1	2	1	2
p	2	3	6	10	3	8	3	7	6	3	7	11	5	3	8
q	0	1	2	4	4	5	3	2	2	3	4	4	4	4	2
r	2	3	6	2	0	3	3	4	4	7	2	8	2	2	4
s	0	14	4	14	18	5	7	9	8	14	14	20	5	7	5
t	1	4	8	11	8	2	11	12	9	9	9	9	6	10	2
u	0	2	5	3	4	7	3	4	2	2	3	5	3	3	4
v	2	4	13	13	26	14	12	35	12	7	1	14	15	29	20
w	2	4	9	8	8	10	12	12	11	8	5	15	9	16	12
x	0	2	6	1	3	7	7	2	3	11	2	2	2	4	7
y	1	5	2	4	3	4	9	13	9	9	6	10	4	5	4

Table 2: locker module demand for access hub locations (part b)

<i>Location</i>	<i>t=16</i>	<i>t=17</i>	<i>t=18</i>	<i>t=19</i>	<i>t=20</i>	<i>t=21</i>	<i>t=22</i>	<i>t=23</i>	<i>t=24</i>	<i>t=25</i>	<i>t=26</i>	<i>t=27</i>	<i>t=28</i>	<i>t=29</i>	<i>t=30</i>
<i>a</i>	4	18	14	16	17	14	10	3	19	17	18	20	19	15	4
<i>b</i>	8	8	10	6	9	8	10	5	8	7	11	7	8	10	7
<i>c</i>	5	6	7	7	6	10	9	4	5	9	5	8	5	7	7
<i>d</i>	3	4	5	5	5	4	2	3	6	2	2	1	0	5	3
<i>e</i>	3	16	13	14	16	15	14	4	19	13	11	19	14	17	3
<i>f</i>	10	13	7	10	16	16	12	8	15	15	14	17	15	14	13
<i>g</i>	3	8	6	11	8	6	7	4	6	6	13	9	13	6	3
<i>h</i>	5	24	21	25	23	23	19	5	26	22	26	31	30	20	5
<i>i</i>	5	15	6	16	11	17	16	5	17	9	20	15	11	8	4
<i>j</i>	7	17	17	19	15	19	15	4	18	12	13	24	20	11	7
<i>k</i>	3	8	10	10	10	12	11	4	11	8	12	11	7	6	4
<i>l</i>	10	15	17	14	19	20	20	8	21	22	19	19	20	18	12
<i>m</i>	9	20	10	9	24	11	22	4	26	19	10	10	33	26	6
<i>n</i>	4	9	12	7	7	7	7	4	9	8	9	9	11	8	3
<i>o</i>	2	3	3	1	2	2	2	1	0	0	1	4	3	0	1
<i>p</i>	4	6	5	12	10	7	6	5	8	8	8	9	9	7	5
<i>q</i>	2	1	3	1	3	1	3	2	2	2	0	3	3	3	2
<i>r</i>	6	3	6	2	6	5	9	4	6	4	9	4	10	10	5
<i>s</i>	16	14	3	10	7	8	12	6	6	8	18	4	6	10	19
<i>t</i>	7	7	9	13	10	13	10	7	9	10	11	12	12	13	5
<i>u</i>	2	7	6	6	8	3	5	4	6	3	7	5	3	3	3
<i>v</i>	10	15	9	15	37	15	30	4	3	10	12	27	13	31	7
<i>w</i>	7	9	10	15	10	12	18	7	12	7	6	12	13	9	5
<i>x</i>	4	2	3	3	2	1	6	3	10	4	3	11	2	5	1
<i>y</i>	4	3	7	9	11	8	7	6	9	11	10	7	9	9	3

Moving towards practical implementation of self-organizing logistics – making small steps in realizing the PI vision by raising awareness

Hans Quak¹, Elisah van Kempen¹ and Meike Hopman¹

¹TNO, The Hague, The Netherlands

Corresponding author: hans.quak@tno.nl

Abstract: *The long-term Physical Internet (PI) vision assumes that all logistics will be self-organizing, shippers and receivers are connected via PI and routing on this network as well as handling of assignments are standardized and optimized. Although this PI vision is appealing, academically as well as for logistics industry, many logistics practitioners have difficulty to see the short term implications or opportunities arising from realizing (the first steps) of this PI vision. This contribution aims at bridging the gap between the long term PI vision and its short term implications for logistics practitioners, by showing how and where a more self-organizing logistics (SOL) system can have benefits in the daily logistics operations at this moment. This contribution discusses two different ways to raise awareness among logistics practitioners and learn what SOL could do: i.e. a serious game and experiments in practice. This paper aims to add a more practical approach to the existing literature on Physical Internet and Self-Organization in Logistics.*

Keywords: *Physical Internet, Self-Organizing Logistics (SOL), Serious gaming, Practical experiments*

1 Introduction

1.1 The logistics system in a changing world

Transport is one of the most difficult and complex sectors to decarbonize. The Paris agreements require a serious decrease in the GHG emissions of transport; or – differently said – a six fold increase in the carbon productivity (see Connekt, 2017). And this not only applies to freight transport, but for the entire logistics system. As Montreuil (2011, page 1) states: “the way physical objects are currently transported, handled, stored, realized, supplied, and used throughout the world is not sustainable economically, environmentally, and socially” and “Addressing this global unsustainability is a worldwide grand challenge, hereafter termed the global logistics sustainability grand challenge”.

This grand challenge requires big changes in the existing logistics system. Next to the grand challenge, we observe several independent external trends and drivers that each bring about their own changes to the logistics system (Connekt, 2017), now and in the future, and create business opportunities, as well. Among the most evident external drivers, next to the requirement to dramatically improve the sustainability of the logistics system, are:

- the developments towards automation and robotization, bringing productivity to a new level, making solutions affordable that were previously seen as prohibitively expensive. The obvious target is to reduce handling costs at warehouses, cross-docks and delivery. Autonomous vehicles could do away with the need for a driver and allow for completely new logistics models,

- as well as the increase in connectivity in the physical world, i.e. further integration of the digital and physical world: the Internet of Things. In this connected world, cheap computers-on-a-chip with very low power requirements are currently being combined with sensors and new forms of wireless connectivity, allowing them to be attached to physical objects and travel with them while staying connected (constantly or intermittently). Traceable physical objects (goods) mean transparency of the supply network to the final customer at every step and customer intimacy based on transparency instead of trust.

These three developments, i.e. the requirement for more sustainability, automation and robotization, as well as the IoT-applications are to determine how the logistics system develops the coming years. Adding to these developments, we argue the increasing demanding customer also stretches the boundaries in which logistics can develop in the coming years following the considerable growth in home deliveries (in e.g. parcels, groceries and meals) following from e-commerce. As supply networks service a customer-dominated environment driven by timelines and customer convenience. Customer intimacy is key to understanding the demands for transport, the logistics requirements as well as the value-added services. Logistics services are key to achieve customer intimacy, at a reasonable price. The combination of customer intimacy and low prices – as logistics is often seen a cost item, determines the logistics decision space many logistical practitioners have in their normal day operations.

Concluding, the logistics system is expected to change considerably coming years. On the one hand, this is absolutely necessary to achieve the required sustainability levels. On the other hand, both market developments where final receivers are more and more in the lead and technical developments in automation and robotization as well as in IoT technology provide opportunities to both improve customer intimacy and reduce costs, are already starting to change the existing logistics system at this moment.

1.2 Objectives

Although, we argue that the logistics system will change (or is already changing); for many logistics practitioners a transition towards the vision of the Physical Internet (PI), or towards more Self-Organizing Logistics (SOL) systems, seems something for in the far future. This paper describes two ways how we try to examine with logistics practitioners what the practical value of the PI-vision, and a more self-organizing logistics system in particular, in real life logistics operations could be today already. This paper aims to add a more practical approach to the literature on the Physical Internet and Self-Organization in Logistics (SOL). First, this paper positions itself with respect to the literature. Subsequently it proposes the practical approach through two current projects that the authors are involved with:

- Exploring the possibilities of SOL through serious gaming (section 3);
- Real-life experiments of self-organizing logistics at this moment with a perspective to what these experiments' implications are with respect to a more self-organizing logistics system and the PI-vision (section 4).

2 Physical Internet and Self-Organization in Logistics

The necessity as well as the opportunities leading to a changing logistics system, as discussed in this paper's introduction are not new. A growing number of papers examines the possibilities and limitations of a more self-organizing logistics system. Wysick et al. (2008) for example describe the logistics system as a complex adaptive system, in which self-organization, i.e. more autonomy at a decentral level in the system and local intelligence, can contribute to performance improvements, under the assumption that central direction is not or limited possible. Wysick et

al. (2008) argue that co-evolution, the transition towards the following phases, determines the limits in which the logistics system can be self-organizing. However, as Bartholdi et al. (2010) also explain, outside the boundaries of the system, or if not well designed, self-organization can result in unexpected and undesirable results. Pan et al. (2017) propose the following three main principles of a future Self-organizing Logistics System:

- Openness (meaning that actors and assets can easily enter or leave the system). According to Pan et al. (2017) the Openness-principle includes three essential functions, i.e.:
 - connectivity; to enable the individuals to connect with others and the environment, modularization and standardization of physical assets, information systems and organization models is required.
 - reconfiguration; to deal with changes and disruptions.
 - adaptation; to be able to adopt to others and the environment in order cooperate.
- Intelligence (meaning the object-based capability of local real-time communication and activeness).
- Decentralised control (focusing on collaborative rules and communication protocols, that aim at preventing unexpected or undesirable system outcomes, rather than optimal planning).

Pan et al. (2017) see the Physical Internet as an application of a Self-organizing Logistics System, in which physical assets, information systems and organization models are modularized and standardized to enable the connectivity.

Although the PI vision as well as the idea of a more self-organizing logistics system, with more intelligence at a decentral level, are appealing, Sternberg and Norrman (2017) provide some cautions for logistics practitioners in their PI review and Sternberg and Andersson (2014) do so with regard to decentralized intelligence in freight transport. Sternberg and Andersson (2014) indicate in a critical review that - despite the growing number of studies and articles relating to decentralized intelligence in freight transport - there is little scientific support for the success of decentralized intelligence in logistics and that most research was mainly conceptual and rarely empirical. They conclude their review (of more than 40 articles) with the question if the transport efficiency can improve through more local intelligence. Next, Sternberg and Norrman (2017) discuss in their PI review (of 46 publications) that the majority of the PI literature contributions is conceptual. They conclude “What is crucial to understand from a shipper’s or policy maker’s perspective is that currently there are no well-developed models that illustrate how the move from the entrenched logistics models to the PI could ensue” (Sternberg and Norrman, 2017, page 750). The long-term Physical Internet vision assumes that logistics will be self-organizing, shippers and receivers are connected via PI and routing on this network as well as handling of assignments are standardized and optimized. Although this PI vision is appealing, academically as well as for logistics industry, many logistics practitioners have difficulty to see the short term implications or opportunities arising from realizing (the first steps) of this PI vision. Based on both the promised effects and the benefits of moving towards a more self-organizing logistics system (of which PI could be an ultimate application), this paper aims to add a practical approach to the existing literature on the Physical Internet and Self-organized Logistics Systems that provides – next to appealing as an idea (vision) of the future for logistics practitioners or a technical blueprint for the future logistics system– also practical steps for practitioners to allow them to start experimenting and organizing their logistics innovations in this direction at present. Obviously there could be triggers or visionary companies that start or set-up a PI (kind of) system; the fact that no uptake has been seen in the recent past, does not that it will not happen in the future. So, although we cannot predict whether and how the PI concept will develop, our approach is to explore with logistics practitioners what added value can already be in parts of the concept at this moment.

One of the first questions that comes up then is, what are or can be the drivers for logistics companies to actually make the first steps in the direction of a more self-organizing logistics system. Following Pan et al. (2017) we assume that this, at a company level, would mean that the first steps basically start with increasing both local intelligence (following from the external developments and robotization automation and IoT possibilities) and decentralized control, as these developments offer (technical) opportunities to better serve the final customers. The obvious advantage of decentralization of logistics coordination and control is the increased robustness to deviations and the prevention of spreading of (local) disturbances.

Next to this increased robustness, which is already often the reason for logistics practitioners to in (further) decentralize logistics coordination and control, we also see another business opportunity that might interest logistics practitioners to decentralize; following among others McFarlane et al. (2016), adding local intelligence and / or more decentralized decision-making power at a system level will not necessarily lead to kilometer-efficient logistics, but it enables for better customer intimacy. McFarlane et al. (2016) indicate that especially intelligent logistics systems allow for a higher degree of receiver (customer) orientation, in which decentralized intelligence is required. In this way the logistics system is able to answer to developments as:

- individualization of customer demand (including further diversification in delivery options);
- more transparent planning and execution, and as a result the ability to communicate about deviations, whether or not due to external factors, such as varying from traffic jams, recipients not being at home for the package delivery, etc., and;
- further automation of more components within the logistics process, in which local intelligence of people will be replaced by more automated processes, which also raises the question, at which level which decisions should be taken autonomously and how to arrange the systems accordingly.

It is precisely in these cases that more decentralized intelligence (or decision-making powers) could lead to solutions, which may initially not be optimal (compared to centralized planning), but which can lead to a quick and reasonable solution within the reality that has arisen. And for these cases it might be interesting for logistics industry parties to make the first steps that are in line with a more self-organizing logistics system.

Figure 1 presents an overview of how the logistics system could change by external trends and drivers. The developments towards automation and robotization enable a further integration of the digital and physical world: the Internet of Things. An increase in the use of sensor technology and a better connected world create opportunities for data sharing and real time visibility. Together, these external trends and drivers create a base of possibilities for the transition of the logistics system. Starting from this base, the logistics system can evolve into a more self-organizing logistics system, a centrally steered system, or a hybrid form in between those options. At the moment, we think this mainly depends on the requirements the logistics systems needs to answer. We do not argue all logistics systems and supply chain configurations should be self-organizing, but for some sectors we see direct opportunities. This is illustrated both in section 3 on the serious game about self-organizing logistics as well as in section 4 on the proposed practical experiments in the parcel delivery system.

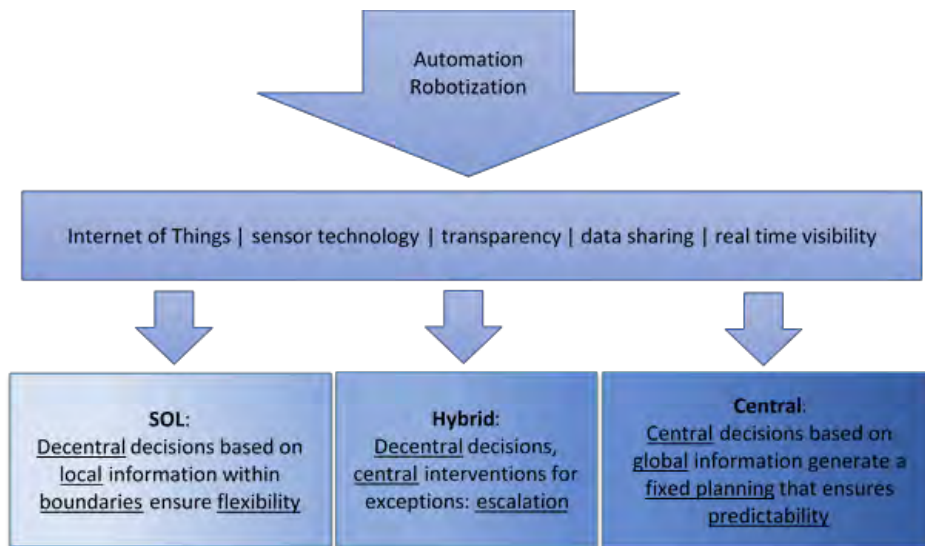

Figure 1: First steps in transition of logistics system

3 Exploring possibilities of SOL via serious gaming

3.1 Why serious gaming?

The body of literature on the Physical Internet and Self-Organizing Logistics (SOL) continues to grow. However – as it is argued before – the majority of the literature is conceptual and there is relatively little empirical exploration performed yet. Based on the conceptualizations in the literature (e.g. Pan et al, 2017; Bartholdi et al, 2010) several potential advantages of a more decentralized system can be formulated. As the practical side of PI is relatively underexamined and for many logistics practitioners PI seems to be more a far future vision than something that can have practical value in real life logistics operations already, serious gaming can be a useful tool to move towards a more practical approach of PI and SOL. Serious games differ from regular games as the main purpose of a serious game is to learn and generate changes in behaviour (Lebesque, et al., 2017).

Especially for logistics practitioners who are not yet dealing with the developments, opportunities nor barriers, on SOL, gaming can be used to move towards a more practical approach. This is also underscored by Lebesque et al. (2017) who argue how serious gaming can help preparing for the future. Serious gaming is useful for raising awareness as parties can gain insights into the implications of logistics innovations. Next, serious gaming can be used as a tool to facilitate discussions and generate new ideas. On top of that, serious games are useful for creating a safe testing and experimentation environment: “Implementing innovations to deal with new developments in the logistics process, usually involves many risks since practical implications are rarely clear. By simulating the barriers and issues of new developments, serious games enable all the respective parties to work out new solutions” (Lebesque, et al., 2017; p.5).

To conclude, as the possibilities (as well as threats) of a more self-organizing logistics system are only just starting to become on the minds of logistics professionals, serious gaming can help raising awareness of current developments (both in academia and in practice), facilitate discussion and provide a safe testing environment. Therefore, we developed a serious game to explore the possibilities of Self-Organizing Logistics, i.e. “Solve it!”.

3.2 Solve it! – A serious game for exploring SOL

3.2.1 Aim

The aim of Solve it! is to make logistics parties aware of the developments that are observed: an increasing demanding customer, increased need for flexibility, adaptability and resilience in the supply chain and opportunities regarding improved algorithms and sensor technology – and the potential impact of these on their organization. The target audience are (strategic) logistics managers from logistic service providers or shippers.

In Solve it! the players explore potential advantages and disadvantages of a more central organization structure versus a more decentral (SOL) organization structure. The game demonstrates the impact of choices by creating, evaluating and comparing two different organization structures. In the workshop of which the game is part of, players are asked to translate their findings to their current logistics practice.

On purpose, it is decided not to favour one organization form over the other. To date no empirical results are known that self-organization outperforms other organization forms with respect to efficiency, resilience, customer satisfaction, sustainability or any other KPI. Therefore “Solve it!” intends to open up the discussion and does so by tempting players to contrast extreme organization forms to explore the possibilities and constraints (see Figure 2).

Type	Board game
Duration	2,5-3 hours
Participants	2-3 players per board
Target audience	Logistics managers (strategic level)
Objectives	Raise awareness, generate new ideas, experiment in a safe environment
Gameplay	In teams players design, evaluate and compare the organization structure for two cases with varying product and supply chain characteristics.

Figure 2: Features of “Solve it!”

3.2.2 Approach

In order to build an effective serious game, the Goal Design Alignment (GDA) Method was applied (Van Der Hulst, 2014). The first step is to translate the goals of the game into required competences and experiences of the players as a result of the game. Subsequently behavior that needs to evoke these, needs to be specified. Next, the game design can be aligned with these specifications of the goal. The game design consists of two components;

1. the small game, the tangible game with its core elements and structure;
2. the big game, that incorporates the didactic and organizational embedding (i.e. surroundings, brief, debrief, setting) and the small game.

“Solve it!”, like many other serious games is delivered in a workshop setting. The workshop is part of the big game and is also designed in the design process. The design phase is an iterative process: it involves continuously testing and readjusting of the design in order to meet the goals that are set.

3.2.3 Description of the small and the big game

The big game of “Solve it!” consists of five phases, which are shown Figure 3. In the first phase, players enter the future world of “Solve it!”, where more advanced algorithms, sensors and autonomous transport modes are available. The players are confronted with two cases of two

different products and a given supply chain for each of the products (Product A: very flexible demand, demanding customer, short time to market, high value product; Product B: stable demand, bulk product, dual use product, additional checks by customs and safety regions).

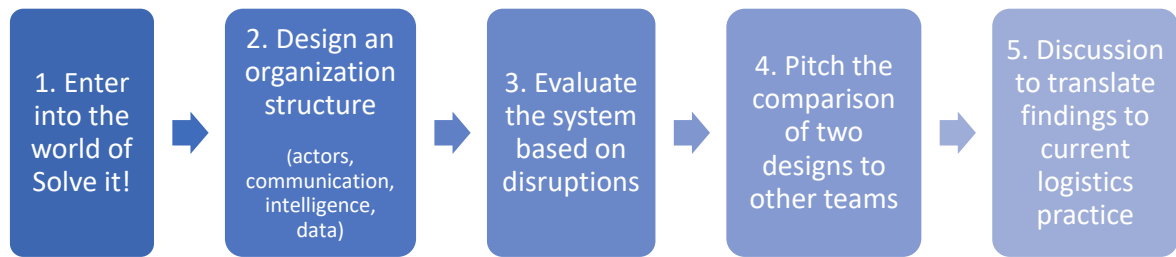
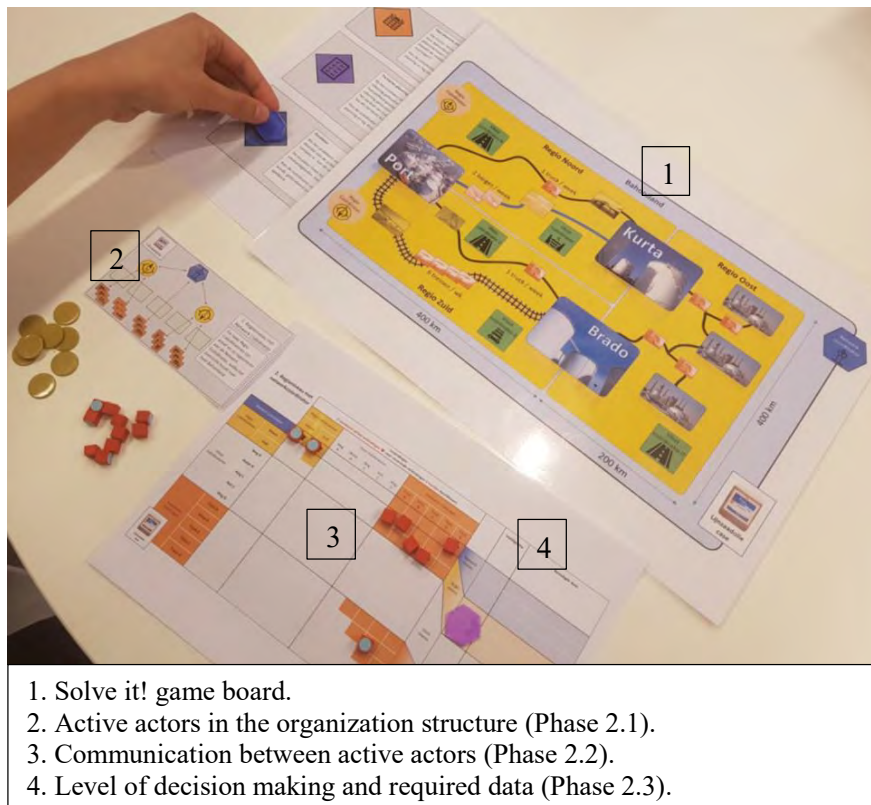

Figure 3: Phases of “Solve it!”

In Phase 2 the task of the players is to design the organization structure for each of the two cases based on the characteristics of the product and the supply chain as described in Phase 1. An example of an organization structure is shown in Figure 4. Creating an organization structure (Phase 2) consists of three sub phases:

- 2.1 decide which actors are active in the network;
- 2.2 choose which actors can communicate with each other; and
- 2.3 decide on which level in the organization structure decisions are being made and which data is required on the different levels.



1. Solve it! game board.
 2. Active actors in the organization structure (Phase 2.1).
 3. Communication between active actors (Phase 2.2).
 4. Level of decision making and required data (Phase 2.3).

Figure 4: “Solve it!” Phase 2 design an organization structure

When making decisions regarding the actors that are active in the network, players can choose between either more central actors such as a network coordinator who can control the whole network, or less central actors such as fleet coordinators who only control their own fleet.

Subsequently, in Phase 2.2 it has to be decided who communicates with whom (vertical or horizontal communication lines) and how these actors communicate (via standardized data connections or ad-hoc using phones). In Phase 2.3 the players finish the design of their organization structure by deciding on which level operational and tactical decisions are being made (location of intelligence) and which data is required for that.

When the organization structures are created, the players continue with the evaluation phase (Phase 3). In this phase several disruptions occur, and the players have to determine how well their logistics system responds to these (un)expected events with respect to operational and coordination costs. Phases 2 and 3 are repeated for the second case description that requires a new design of the organization structure based on the different requirements of this product and its supply chain. In Phase 4, players compare the two different organization structures that they have designed. Players present this comparison to other teams in the form of a pitch in which they reflect on both the choices that the players have made as well as on the performance of the different organization structures regarding the disruptions in Phase 3.

In the final phase a group discussion is set up with the players from all teams to translate the findings of the previous phases to current logistics practice (Phase 5). Amongst others the following questions are explored: Which characteristics of products or supply chains plead for a more central or a more decentral organization structure? To what extent are you aware of the upcoming trends and changes in the logistics system? What is the impact of these trends and changes on your own organization? Which steps could you take now to be prepared for the logistics of the future?

3.2.4 Preliminary results

To date, the game is in the stage of finalization and several experiences have already been gathered in the experimentation phase. It could be observed that the set-up - letting players design, evaluate and compare various organization structures themselves - is an effective way to start a discussion on which level of control is desired under which circumstances. It could be observed that players base their decisions on the product and supply chain specifications as described in the cases and that this results in different choices and organization structure designs. Furthermore, the discussion to translate the findings to current logistics practice (Phase 5) facilitated fruitful discussions. Participants start to think about the level of control that is required to design a resilient logistics system for different cases: Is it really required to put all intelligence and decision making power within one single central actor such as the network coordinator? Or can some decisions also – or even better – be made by more decentral actors such as the autonomous vehicles themselves?

As these discussions start of, gradually the topic shifts from the Solve it! world towards the real world; participants start thinking about the implementation and the more practical side of their designs. Consequently, they are creating a take-home message to discuss within their own organization. The participants in the playtests indicated that playing Solve it! was a fun and useful experience. Some first reactions: “Now I understand that self-organization in logistics goes beyond ‘smart parcels’, it requires you to rethink your organization structure.” and “The workshop is a good conversation starter and makes me reconsider the choices we make in our company.” Another participant (logistics service provider) stated: “in this game you learn how to design a logistics organization based on product and market characteristics. Your basic assumptions and views are challenged. You experience the level of resilience of your organization design and in the discussion you learn from the other players as well, based on the choices they made.”

The playtests and experiments so far have shown some preliminary results that are aimed for. Participants of the Solve it! sessions have experienced the differences between self-organizing logistics and central-organized logistics; and have better insight in the impact of upcoming trends on their own organization and the logistics system as a whole. To conclude, Solve it! helps participants to conceptualize self-organizing logistics which helps them to formulate their company vision and their future steps with respect to SOL to anticipate on the changing logistics system.

4 Real-life experiments on SOL – SOLiD

4.1 Background and reasons for impulse for self-organizing logistics

Another way to raise awareness in logistics industry is by actually experimenting and demonstrating in practice that a more self-organizing logistics system, i.e. a system that enables more decentral decisions, in order to become more flexible, adaptive and autonomous based on the self-learning ability of the system, can have advantages already. February 2018 we started a project, (partly) financed by the Dutch Topsector Logistics (TKI Dinalog and NWO) and answering the call ‘Impulse for Self-organizing Logistics’, called SOLiD (Self-Organizing Logistics in Distribution)¹. The project has to fulfill several conditions according to the call objectives, i.e.:

- The purpose is to enable research in an experimental environment. This is not only about doing the experiment, but also about designing that experiment, and to closely monitor and investigate the progress, performance and redesign of the experiment, so that a demonstrable learning process occurs. This implies a clearly defined case in which the experiment and the learning process will take place.
- The purpose is a proof-of-concept project that shows how logistics systems can be prepared for the Physical Internet. In the way that proof of concept is developed, a practical experiment must play a role.
- The outcomes provide logistics industry practitioners with a perspective with respect to actual opportunities and barriers for a more self-organizing logistics system and the PIVision, as well as provide examples of the first steps in that direction they could take. It should provide an impulse for both research as well as applications of more self-organizing logistics systems where relevant.

Next SOLiD is also partly financed by DPD The Netherlands and two Dutch cities from their Smart City initiatives, and as such some more requirements have to be dealt with in this project:

- The experiments should be feasible on the short term, this means that the experiments should also take a relatively short term business case for logistics industry in account, technology should (more or less) be available and not to be developed in the project, and the experiments should fit within the existing operations (which means that for example companies not involved in the project cannot be planned for in this phase). A short term business case implies that technology should be available at relatively low costs; if this is not the case, the technology might be interesting from a research perspective, but far future for logistics industry.
- There should be a logical reason to assume that a more self-organizing logistics system is an interesting direction for the parcel delivery industry. To answer this requirement: especially in the market of parcels and B2C home deliveries, we see an ever-increasing development in customer-driven logistics, which was argued to be a driver for a more self-

¹ The SOLiD project consortium consists of the following project members: TNO (project leader), DPD Netherlands, PrimeVision, TWTG, Thuiswinkel.org, the cities of Utrecht and Amersfoort and the Dutch universities: Delft University of Technology, Eindhoven University of Technology, Erasmus University Rotterdam and University of Groningen.

organizing (decentral) logistic system, where web shops and carriers try to distinguish themselves by increased customer intimacy. Examples of this can be found in recent start-ups such as Parcify (see parcify.com), but also in existing courier services such as My Choice by UPS and Fedex's Delivery Manager. In order to be able to plan the last mile deliveries in an as efficient as possible way, but allow for some flexibility until a late moment, a form of decentralized decisions (whether or not after communication with the receiver) can be a solution. Note, there are other ways to influence receivers' behavior (e.g. by a form of dynamic pricing of delivery timeslots; see Agatz, 2009 for revenue pricing in last mile deliveries), which can also lead to increased customer intimacy, but do not include decentralized decision-making. Besides, the parcel delivery industry faces serious challenges next to the increasing receiver demands on the final delivery: i.e. the volumes in this industry are rapidly increasing due to e-commerce and the industry is relatively high labor-intensive (although some parts are automated especially in sorting).

All these requirements resulted in the planning of four different experiments in the parcel-delivery industry, that can run in the present, but can provide perspective in how and if a more self-organized logistics system would add value for the parcel delivery- and the logistics industry.

4.2 SOLiD's experiments in the parcel delivery industry

This contribution discusses SOLiD's four cases in the experiment, and how these can contribute to realizing some practical steps in the PI vision. These cases are planned in different areas of the parcel delivery process: planning of delivery areas, sorting and handling, route-planning and route performance learning. We shortly introduce the planned experiments and how these can contribute to the perspective towards a more self-organizing logistics system. The experiment might be case-specific, as it starts from the current situation at DPD in the Netherlands (although, this is also subject to rapid change, as is the entire industry). The perspective we try to provide with regards to a more self-organizing system should be more generic. We do so based on simulation (including data from the experiments) as well as based on a broad expert panel that interprets the results and discusses what the broader more general perspective could be.

4.2.1 More dynamically planning delivery areas based local information

The first case concerns the different planning of delivery areas in which delivery vans are active. In the current situation, the delivery areas in which one van delivers the parcels are already known before the sorting process in the sorting center. These areas are determined based on historical data and are replanned every few months; the routes (and delivery areas in which the routes take place) contain a combination of B2B (business-to-business) and B2C (business-to-consumer) deliveries and pickups. The routes are executed during the day: B2B in the morning at the beginning of the route, and afterwards the B2C home deliveries. In the current situation, the number of successful B2C deliveries in the early afternoon is relatively low because many receivers are not at home. In this case, we aim to plan the delivery areas more dynamically taking in account the classification of the chances of successful deliveries - on the base of address intelligence or area intelligence that will be developed (as a start). The question here is also how many parcels data is needed to determine these delivery areas better than the current situation. This case provides a view of possibilities for decentralized sorting, where packages determine (in part) in which delivery area these are classified, assuming that (in time) parcels contain more information than these do now. One direct implication of more self-organized sorting, in which for example small robots can sort, could be used in the parcel industry to

handle peaks, as now parcel industry needs to invest heavily in increasing sorting infrastructure to keep up with the increasing (peak) volumes (see for an example CNBC, 2017).

4.2.2 Adding local intelligence in order to reduce handling activities

The second case in SOLiD concerns the addition of local intelligence at the parcels in order to reduce handling activities during the loading of the vans (for final delivery) by the drivers. At this moment most often the vans used for the final deliveries are loaded by drivers, as they need to know where exactly the parcels are placed in the van in order to reduce the seeking time during the delivery roundtrips.

This case examines the part of the process after sorting in which several manual actions are needed. The hypothesis is that the easier - faster / better / cheaper / more efficient - the handling of a package becomes, the sooner self-organization can be realized. Therefore, this case examines how to make multiple transfers of a parcel as cost-effective possible. In this part of the experiment we make a comparison between increased central and increased decentralized intelligence. Within this part, the following are planned:

- Increase local intelligence through the projection of the location of the package in the van: by means of a projector, the parcels are indicated exactly where in the van the specific parcel must be placed. The duration (and therefore performance indicator "costs") to find the right parcel in the van (before delivery) is measured.
- Increased decentralized intelligence by taking photographs on the sorting belt of each package (2- / 3D). The barcode of each package is linked to the relevant photo. Next, the van driver is enabled through an interface (e.g. a smartphone) to view the picture of the package on the mobile phone. The duration (and thus performance indicator "costs") to find the right package in the delivery van is measured (and compared to the first situation).

Both cases add local information in the parcel delivery process that enables to disconnect the loading of the van from the driving of the van. This shows how parts of the process could be further automated, as well as it provides an example of how, in a more self-organized (like PI application) situation, van drivers can easily distinguish the right parcel – even if it comes from other networks and is not loaded by the driver. If this fits within project budget (which means no serious problems occur in the execution of the projector described earlier), we plan to experiment (in a lab setting, so not in the direct operations) on a small scale with the recognition of parcels in a delivery van using RFID as an alternative to the photo.

4.2.3 Continuous replanning of delivery routes based on receiver feedback

The third case in SOLiD's experiment concerns the replanning of the roundtrips based on receivers' feedback. This case follows from the assumption that the parcel delivery industry develops in a more and more adaptive way in the future towards serving the final customers. Adding decentralized intelligence to the parcel delivery system enables a parcel deliverer to respond to specific recipient's demands or needs. In this part of the experiment we investigate the effect of adding decentralized decision-making power on the performance indicators "hit-rate", "accuracy of time period" and "kilometers". The long term perspective in this case is that the parcel itself can communicate with the final recipient and negotiate a feasible delivery timeslot and place. Feasible implies that it is cost-effective (which means it fits the roundtrip planning more or less) and not changing too often and too late (so that this type of customer intimacy does not result in a dramatic increase of the delivery kilometers). However, this is the long term perspective, for the moment we anticipate the following activities in this case:

- After the vans are loaded / after sorting in the delivery areas, a recalculation based on address intelligence for each route is made, where the optimization of the hit rate is central.

The effect on hit rate and driven kilometers (directly and indirectly by less kilometers for second delivery attempt) are measured.

- In the second instance, a variable number of receivers are approached, which usually are not or are at home on the planned delivery moments after optimization. Based on the feedback, decentralized replanning will be done of the roundtrip (note: swapping between routes is not possible in this case) in which a new time slot can be chosen (considering the effect of the already issued time slots to other recipients), another location (if appropriate in the route), or another ride (the parcel must be returned to the system and will be delivered the next day) or another delivery option (for example at the neighbors or a parcel shop). This experiment partly depends on what is possible within the existing systems and what shippers allow with regard to communication towards the receiver. In addition to the options mentioned there are other possibilities, such as social delivery, new local parties, and the use of startups for whom delivery address is flexible (such as Parcify) that meet the specific recipient needs.

4.2.4 Making local intelligence of good-performing drivers available

The final case in the experiment, aims at learning to find and capture local intelligence. At the local level drivers currently make autonomous decisions. In practice, one driver performs better than another. In this case we plan to learn from differences between drivers and their decisions. The question here is whether, and in what way, intelligence of high-performing drivers can be used by other drivers and how to set-up the right rules and protocols. Where does a driver do something different than expected, is it possible to record it and explain why this happens and what information is used for this.

4.3 Dealing with limitations

Both the PI vision as the idea of a more self-organizing logistics system might, as discussed earlier in this contribution, be appealing. However, the first steps in the transition paths towards these visions seem to be quite difficult in current logistics practice. Several reasons can be mentioned, such as:

- it does not match with current stakes of logistics players in the existing markets;
- most potential is realized in case, next to intelligence and decentralized control, also the third component mentioned by Pan et al. (2017), i.e. openness, is in place.
- there is a big difference in demonstrations of technology, in which on a small scale the objective of the demonstration is to show that something could actually be used well technologically (i.e. proof of concept) and experiments that have to use existing technology and function in today's operations and do not aim at demonstrating the technology, but more the potential of this idea / vision on the long term. However, actually experimenting could be the first step for current logistics practitioners to actually change their ideas and make the first steps in actually transforming towards a more self-organizing logistics system, at these areas in the supply chain where it makes sense.

With these points in mind, we developed the different cases in SOLiD's experiment. But, there is more in the project than that: the interpretation of the results from the experiments, the long term perspective of the experiments in relation to how the learnings and experiences contribute to (the first steps) in realizing a logistics system that can be more sustainable and increase customer intimacy are very important. If one considers the experiment's cases without that, the project would lose most of its value, as some (or even all) of these cases are already trialed (as a proof of concept) or even sometimes already running in some logistics systems elsewhere. To make sure we are able to do more than just the experiment's cases (and to make sure that SOLiD

can actually be an impulse for self-organization in logistics) we also planned different ways to interpret the results in the long term perspective:

- We develop a simulation environment which allows us to simulate cases 1 and 3 in more detail and in which we can vary more than in the actual experiments.
- We have regular meetings with a broad group of experts (both from practice and academia) to interpret the cases' results and together further develop ideas and potential projects for other parts in the (parcel delivery) logistics system to be more decentralized where it makes sense, and we examine to which other logistics systems these results could be transferred and how.

These activities are as important for the project results, as otherwise we run the risk that the project is seen as a collection of four (not too innovative) proof of principles. Therefore, it is important for the project to always present the experiment's cases and the results in combination with this perspective, so that we can show that the SOLiD's results are eventually more than the direct results of the four experiment's cases.

5 Concluding discussion

As most of the literature on both the Physical Internet and Self-Organizing Logistics (SOL) is conceptual and there is relatively little empirical exploration performed yet on these related topics, the concepts seem to be far future (but appealing) visions, rather than provide practical opportunities for logistics practitioners. For these practitioners, being for example shippers, logistics service providers or policy makers, there is currently no clear direction or set of actions on how to move themselves or how to start moving the logistics system they are operating in the direction of more self-organization (and PI as ultimate application). Although, it might seem difficult to find the first concrete steps, we argued that by actually following the existing external developments is best to actually involve existing logistics industry. The requirements from answering the global logistics sustainability grand challenge, as well as the opportunities in either reducing costs or improving customer intimacy due to robotization and automation, as well as IoT- and sensor technology, are going to change the logistics system. By putting these developments in the perspective of a more self-organizing logistics system and eventually in the PI vision, it might be possible to steer these developments in that direction.

This contribution deals with two different ways how we tried to make both the idea of a more self-organizing logistics system, as well as the Physical Internet as an ultimate application of that, more concrete for practitioners. So that we can practically examine where and for whom benefits to expect. As practical and empirical evidence on the impacts of moving towards more self-organization in logistics, is still limited, a serious game can be a good way to start discussion and especially to let the more innovative logistics parties start making up their minds in which direction to develop in the (near) future, like in the serious game "Solve it!". Setting up practical experiments in order to actually show that some of the mentioned developments can already provide opportunities now, in relation to more options later (in line with the PI vision) is another way to actually make the first moves in the direction of examining the potential benefits (as well as pitfalls) of a more self-organizing logistics system.

These practical (more bottom up) approaches are complementary to the growing number of especially conceptual contributions on the Physical Internet, and have the potential to enrich the discussion. Obviously, the gap between the long term vision and what is feasible in practice for a limited group of stakeholders (or even one company) is not bridged directly, but approaches like the "Solve it!" serious game and the learning experience in SOLiD's four experimental cases can be considered as first steps to do so.

Acknowledgements

The authors like to thank the Dutch Topsector Logistics (TKI Dinalog and NWO) for the support to Project SOLiD (NWO project number 439.17.551), as well as Bernd van Dijk (PrimeVision) and Majorie Damen (DPD the Netherlands) for their inputs.

References

- Agatz, N. (2009): Demand management in E-fulfillment. Doctoral thesis: Erasmus University Rotterdam (Rotterdam: Erasmus Research Institute of Management (PhD Serie 163).
- Bartholdi J. J., D. D. Eisenstein, Y. F. Lim (2010): *Self-organizing logistics systems*. Annual Reviews in Control 34, 111-117.
- CNBC (2017). Retrieved 30-04-2018 from <https://www.cnn.com/2017/04/11/chinese-firm-halves-worker-costs-by-hiring-army-of-robots-to-sort-out-200000-packages-a-day.html> .
- Connekt (2017): *Outlook City Logistics 2017*. Topsector Logistics. Retrieved 30-04-2018 from greendealzes.connekt.nl/download-outlook-city-logistics/
- Lebesque, L., J. van Meijeren, M. de Boer, and S. Kosterman, (2017): Serious gaming for logistics - preparing for the future. The Hague: TNO.
- McFarlane, D., V. Giannikas, W. Lu, (2016): *Intelligent logistics: Involving the customer*. Computers in Industry, v81, 105-115.
- Montreuil B. (2011): *Towards a Physical Internet: Meeting the Global Logistics Sustainability Grand Challenge*, Logistics Research, v3, no2-3, 71-87.
- NWO (2017). *Self-Organising Logistics in Distribution (SOLiD)*. Retrieved 30-04-2018 from: <https://www.nwo.nl/en/research-and-results/research-projects/i/91/30991.html>
- Pan, S., D. Trentesaux, and Y. Sallez, (2017): *Specifying Self-organising Logistics System: Openness, Intelligence, and Decentralised Control*. In T. Borangiu et al. (eds.), Service Orientation in Holonic and Multi-Agent Manufacturing, Studies in Computational Intelligence 694, 93-102.
- Sternberg, H. and M. Andersson (2014): *Decentralized intelligence in freight transport - a critical review*. Computers in Industry, v65, 306-313.
- Sternberg, H. and A. Norrman (2017): The Physical Internet – review, analysis and future research agenda. International Journal of Physical Distribution & Logistics Management, v47, no.8, 736-762.
- Van Der Hulst A., R. Boonekamp (2014): Game-Design Alignment Framework.
- Wycisk, C., B. McKelvey and M. Hülsmann (2008): *“Smart parts” supply networks as complex adaptive systems: analysis and implications*. International Journal of Physical Distribution & Logistics Management, v38, no.2, 108-125.

Optimising the Capacity of Parcel Lockers

Russell G. Thompson^{1*}, Cheng Cheng¹ and Kun An²

1. Department of Infrastructure Engineering, The University of Melbourne, Australia

2. Department of Civil Engineering, Monash University, Australia

*Corresponding author: rgthom@unimelb.edu.au

Abstract: *Hyperconnected City Logistics involves creating an integrated, open and shared urban logistics network. Parcel lockers provide a flexible option for receivers to pick up goods and can provide substantial financial savings for carriers as well as environmental benefits for residents. There is a need to improve methods for determining the optimal number and type of lockers at parcel locker stations. Providing too many lockers can lead to additional capital and operating costs, whilst too few can lead to customers not being able to pick-up their goods at their nominated location. This paper describes a model developed for determining the optimal capacity of parcel lockers. Systems analysis as well as a model for minimising the costs associated with parcel lockers is presented. Demand for a parcel locker is characterised by the number and time that parcels are delivered. Utilisation is estimated by combining demand with customer pick-up times. The model is applied to estimate the savings in capital and operating costs for incorporating uncertainty as well as financial benefits of offering incentives for early pickups.*

Keywords: *Parcel lockers, parcels delivery, optimisation*

1 Introduction

Hyperconnected City Logistics involves creating an integrated, open and shared urban logistics network (Crainic and Montreuil, 2016). Parcel lockers provide a flexible option for receivers to pick up goods and can provide substantial financial savings for carriers as well as environmental benefits for residents.

Due to growth in e-Commerce, deliveries to households is increasing the financial costs of distribution for carriers in metropolitan areas. Parcel lockers have a number of benefits in terms of freight traffic, replacing shopping trips due to chain trips and consolidation delivery from depots to parcel locker stations. Parcel lockers have good potential for reducing the economic and environmental costs associated with e-Commerce providing an effective City Logistics solution (Thompson and Taniguchi, 2015).

There is a need to improve methods for determining the optimal number and type of lockers at parcel locker stations. Providing too many lockers can lead to additional capital and operating costs, whilst too few can led to customers not being able to pick-up their goods at their nominated location.

Although there has been numerous studies investigating the attitudes of e-Commerce users towards parcel lockers in last kilometre distribution (de Oliveira et al., 2017; Iwan et al., 2016 and Morganti et al., 2014) there seems to be very limited investigations of the financial costs for logistics companies and levels of service for customers of parcel locker systems. An increased understanding of the fixed and operating costs associated with the provision and management of parcel lockers is important for their planning and operation.

2 Model Overview

It is important to predict and understand more about the costs and performance of parcel lockers to promote their implementation in cities. There is a need to minimise the costs associated with providing parcel lockers.

The major factors affecting utilisation of parcel lockers are:

- Demand (number of parcels delivered to warehouse from on-line sales to be picked up),
- Deliveries to lockers (number of parcels, number of times per day & time delivered), and
- Pickups from consumers (time of day & number of days after delivery).

There are a number of costs incurred by logistics companies when providing and operating parcel lockers, including costs associated with:

- locker installation (\$/locker unit),
- delivery of parcel to locker (\$/parcel),
- return from locker (\$/parcel), and
- delivery failure (\$/parcel).

The model described here has several exogenous variables, such as:

- Percentage parcels picked up 1st day, 2nd day and not picked up,
- Daily profile of pickup times, and
- Demand (parcels per week, % each day)

The objective function to be minimised includes capital and operating costs. Constraints are specified to consider levels of service as well as days or customers to pickup their parcels.

The main decision variable considered here is the capacity of the locker station. Whether there should be multiple deliveries to a parcel locker station also should be determined.

3 Model Formulation

In this problem, we assume all the parcel lockers are the same. The model is developed to optimise the delivery of parcels in one week (excluding weekends). The time step considered in the model is one hour. Based on parcels pick-up pattern generated according to real data, 8:00 am and 14:00 pm are best times for delivering parcels to locker stations. Normally, parcels can be stored in parcels locker for 48 hours. Parcels that have not been picked up within 48 hours will be sent back to the depot.

3.1 Symbols definition

Parameters:

d^T : Total demand in a week

P : Set of weekdays in a week

H : Set of hours in a day

d_p : Percentage of demand in day $p \in P$

q_h : Percentage of parcels picked up in hour $h \in H$

a^1 : Percentage of parcels that are picked up in the first 24 hours

a^2 : Percentage of parcels that are picked up in the second 24 hours

a^0 : Percentage of parcels that are not picked up in 48 hours

c^f : Unit installation cost of a parcel locker

c^o : Parcel lockers operation cost (AUD/day)

c^r : Cost of sending back a parcel that is not picked up with 48 hours
 c^u : Failure delivery cost of a parcel because of the limitation of parcel lockers capacity
 c^d : Unit cost to deliver a parcel
 b : Benefit of successfully delivering a parcel

Decision variables:

N : capacity of parcel locker station
 f_p : Binary variable equals to 1 if there is a delivery at 8:00 am in day $p \in P$
 s_p : Binary variable equals to 1 if there is a delivery at 14:00 pm in day $p \in P$
 F_p : Number of parcels delivered at 8:00 am in day $p \in P$
 S_p : Number of parcels delivered at 14:00 pm in day $p \in P$

Endogenous Variables:

D_p : Delivery demand of parcels in day $p \in P$
 n_{hp} : Number of parcel lockers occupied at hour $h \in H$ in day $p \in P$
 r_{hp} : Number of parcels picked up at hour $h \in H$ in day $p \in P$
 t_p^1 : Number of parcels unable to be delivered at 8:00 am in day $p \in P$ ($t_0^1 = 0$)
 t_p^2 : Number of parcels unable to be delivered at 14:00 pm in day $p \in P$ ($t_0^2 = 0$)
 R_p^1 : Number of parcels that need to be send back at 8:00 am in day $p \in P$
 R_p^2 : Number of parcels that need to be send back at 14:00 pm in day $p \in P$

3.2 Mathematical formulation

Objective Function

$$\min Nc^f + \sum_{p \in P} (t_p^1 + t_p^2)c^u + \sum_{p \in P} (R_p^1 + R_p^2)c^r + \sum_{p \in P} (F_p + S_p)c^d \quad (1)$$

Constraints

$$n_{1p} = n_{24p-1} - r_{24p-1} \quad \forall p \in P \quad (2)$$

$$n_{8p} = F_p + n_{7p} - r_{7p} - R_p^1 \quad \forall p \in P \quad (3)$$

$$n_{14p} = S_p + n_{13p} - r_{13p} - R_p^2 \quad \forall p \in P \quad (4)$$

$$n_{hp} = n_{h-1p} - r_{h-1p} \quad \forall h \in H/\{8,14\}, p \in P \quad (5)$$

$$F_p = [t_{p-1}^2 + d^T d^p] \quad \forall p \in P \quad (6)$$

$$F_p \leq f_p M \quad \forall p \in P \quad (7)$$

$$S_p = [t_p^1] \quad \forall p \in P \quad (8)$$

$$S_p \leq s_p M \quad \forall p \in P \quad (9)$$

$$r_{hp} = [q_h[(F_{p-2} + S_{p-2})a^2 + (F_{p-1} + S_{p-1})a^1]] \quad \forall h \in 1:7, p \in P \quad (10)$$

$$r_{hp} = [q_h[(F_{p-1} + S_{p-2})a^2 + (F_p + S_{p-1})a^1]] \quad \forall h \in 8:13, p \in P \quad (11)$$

$$r_{hp} = [q_h[(F_{p-1} + S_{p-1})a^2 + (F_p + S_p)a^1]] \quad \forall h \in 14:24, p \in P \quad (12)$$

$$R_p^1 = [F_{p-2}a^0] \quad \forall p \in P \quad (13)$$

$$R_p^2 = [S_{p-2}a^0] \quad \forall p \in P \quad (14)$$

$$n_{hp} \leq N \quad \forall p \in P \quad (15)$$

Equation (1) is the objective function which contains four parts. The first part is the installation cost of parcels lockers. The next two parts are the failure delivery costs and costs of sending back parcels that are not picked up in time. The last part is total delivery cost. Constraints (2) to (5) calculate the number of parcels occupied in different hours.

Constraints (6) makes sure the number of parcels delivered at the first time in a day is an integer which is no more than the demand at that time. Constraints (7) make sure the parcels can be delivered in the morning in one day if a delivery is conducted at that day in the morning. Constraints (8) are the integer demand constraints for the second delivery. Constraints (9) make sure the parcels can be delivered in the afternoon in one day if a delivery is conducted on that day in the afternoon. In both (7) and (9), M is known that is big enough, which can be set to d^T in this case. Constraints (10) to (13) calculate and determine the integer number of parcels picked up at different hours in a day. Constraints (13) to (14) linearise the number of parcels that need to return to the depot at each delivery. Constraints (15) are the parcel locker station capacity constraints.

4 Case study

A weekly period of five weekdays was used to estimate the total costs using parameters shown in Table 1. The fixed costs represent the capital, installation and rental costs. The delivery costs are the expenses associated with sorting and transporting the parcels from the depot to the locker station. Delivery failure costs are those costs associated with having to use an alternative (nearby) locker station when the locker station is fully utilised.

Table 1: Logistics Costs

Cost	Value
Fixed cost (\$/locker)	3
Parcel delivery cost (\$/parcel)	5
Failure delivery cost (\$/parcel)	5

Details of the weekday pickup profile for a large distribution organisation operating in Australia was used (Figure 1). To illustrate the trade-off's in cost optimisation a weekly demand of 100 parcels was initially used. It was assumed the 60% of parcels will be collected in the day the parcels are delivered to the station and the remaining 40% the following day.

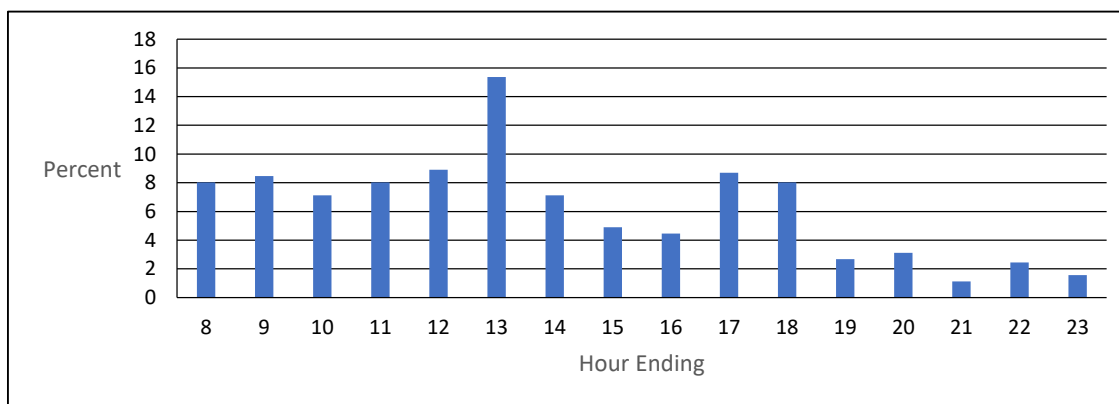

Figure 1: Pickup Profile

Using the costs presented in Table 1 with the pickup profile shown in Figure 1 the model can be used to illustrate the changes in logistics costs when the capacity of the locker station is varied. The effect of the capacity of the locker station on costs can be seen in Figure 2. Fixed

costs increase with increased capacity. However, delivery failure costs decrease with increases in capacity reflecting the reduced likelihood of parcels needing to be transferred to other locker stations. Overall, the minimum logistics costs are achieved when 52 lockers are provided.

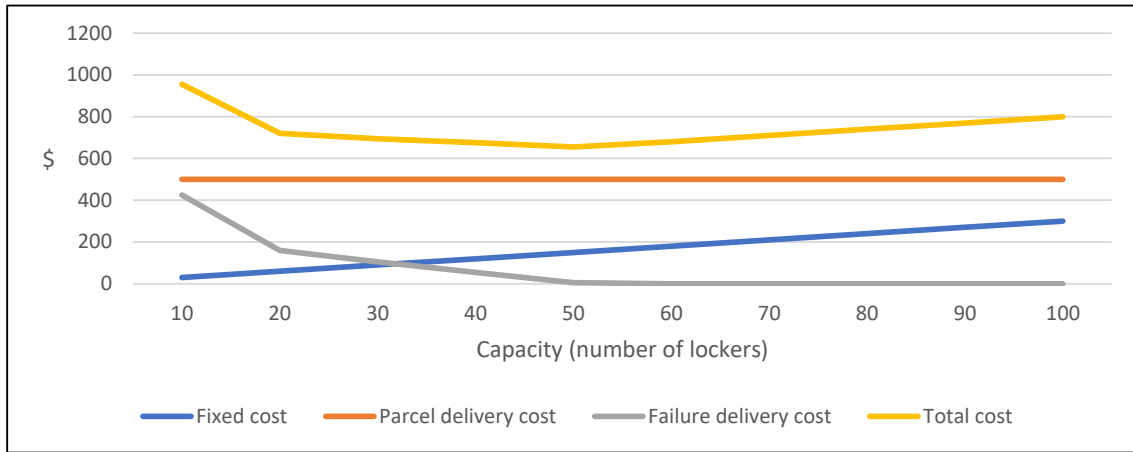

Figure 2: The effect of capacity on logistics costs

The model formulated above was solved using the MIP solver Gurobi 7.5.1 and the implementation was undertaken using Julia 0.6 applying its mathematical programming package JuMP. The testing environment was an Intel Core I7-4770 @ 3.40HZ with 16GB RAM. The running time of the model was less than 0.02 second.

To further illustrate how the model can be used to manage parcel locker stations the demand was increased to 300 parcels per day. Here the model determined the optimal capacity to be 152. Figure 3 shows the cost and capacity difference when the pick-up rates of parcels are different in each day. The daily collection pattern used in this analysis is the am peak pattern show in Figure 4. This figure indicates that the sooner the parcels are collected, the lower the costs are and the smaller the total capacity required is a general trend. Thus, the implementation of some incentives to encourage people to collect their parcels earlier would be a reasonable way to reduce the costs and capacity.

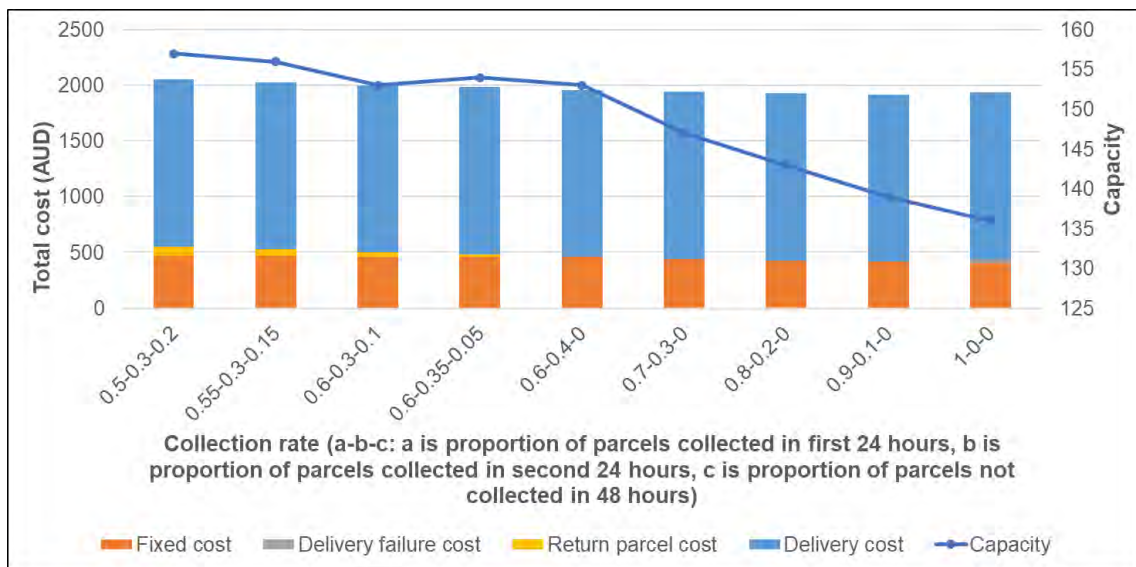

Figure 3: Sensitivity analysis on different parcels pick up percentage in different days

Based on analysis of parcel collection data, different patterns are observed. In this paper, we considered 3 typical ones. In the early pm pattern, there is a collection peak in the lunch time period (between 12:00 to 14:00). In the second, the peak occurs in the morning (between 8:00 to 10:00). The collection rate reaches a peak in the late afternoon (between 17:00 to 19:00) in the last pattern.

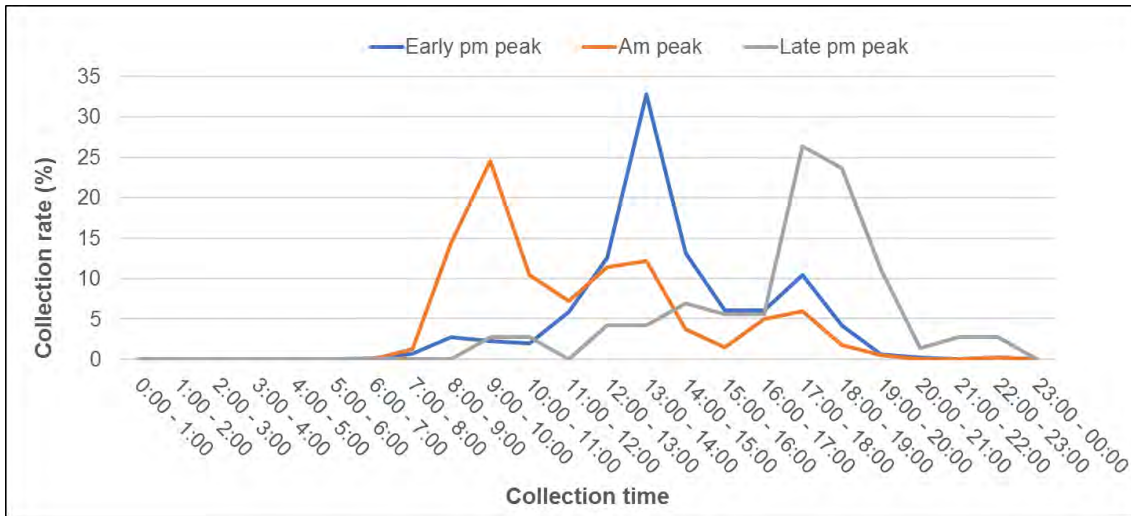

Figure 4: Parcel collection patterns

Figure 5 compares the costs and capacities results based on different collection patterns and the number of deliveries to the parcel locker station (1 means delivery at 8:00 am only, 2 means deliveries at both 8:00 am and 14:00 pm). The collection rate in each day is set to 0.6-0.3-0.1. The results indicate that deliveries twice a day do no reduce the total cost because the unit delivery cost is high if two deliveries are conducted in a day. The pattern of collection has no affect on the total cost as well. However, the capacity required highly depends on the parcel collection pattern.

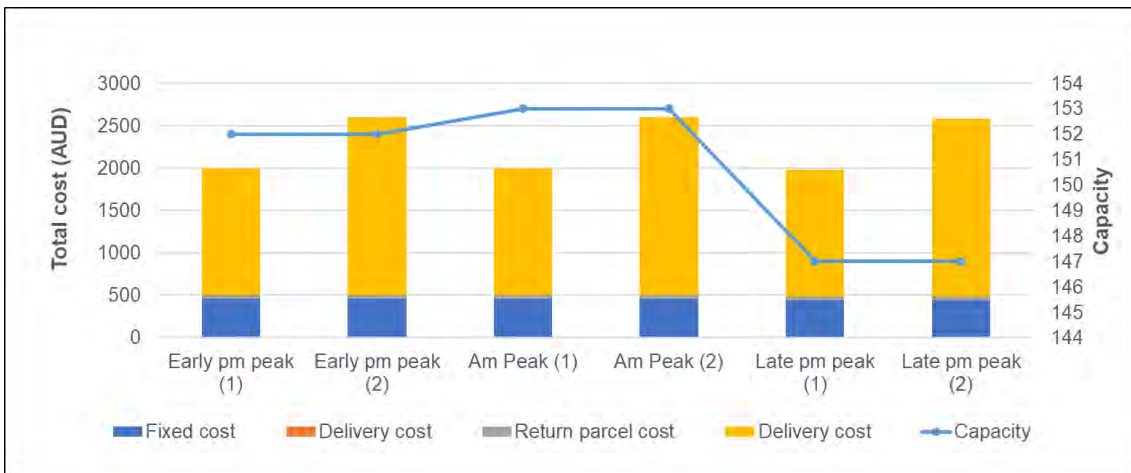
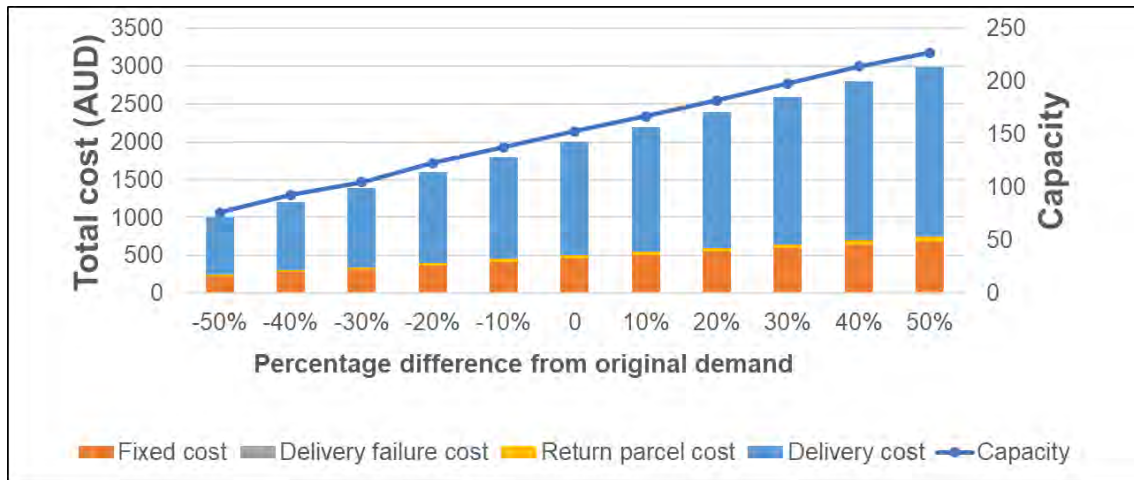

Figure 5: Cost and capacity comparison on different collection pattern and delivery time

Figure 6 shows the sensitive analysis of weekly demand (original weekly demand is set to 300, daily collection pattern used is pattern, collection rate in each day is 0.6-0.3-0.1, delivery once per day at 8:00). The results illustrate that the costs and required capacity has a linear

relationship with demand when the capacity is determined by the model itself (Fig.6 (a)). Nevertheless, if we fix the capacity of the parcel locker, the cost increases exponentially according to the increase in weekly demand. The primary reason for this is the dramatic growth in failure delivery costs when the demand becomes much higher.



(a)



(b)

Figure 6: Sensitive analysis on weekly demand ((a) Capacity decided by the model (b) Capacity is set to 150)

Figure 7 presents sensitive analysis on the costs. The two figures indicate that the raise in both parcel installation costs and unit delivery costs has no impact on the other costs and the required capacity of the parcel locker station, which was determined by the model to be 153.

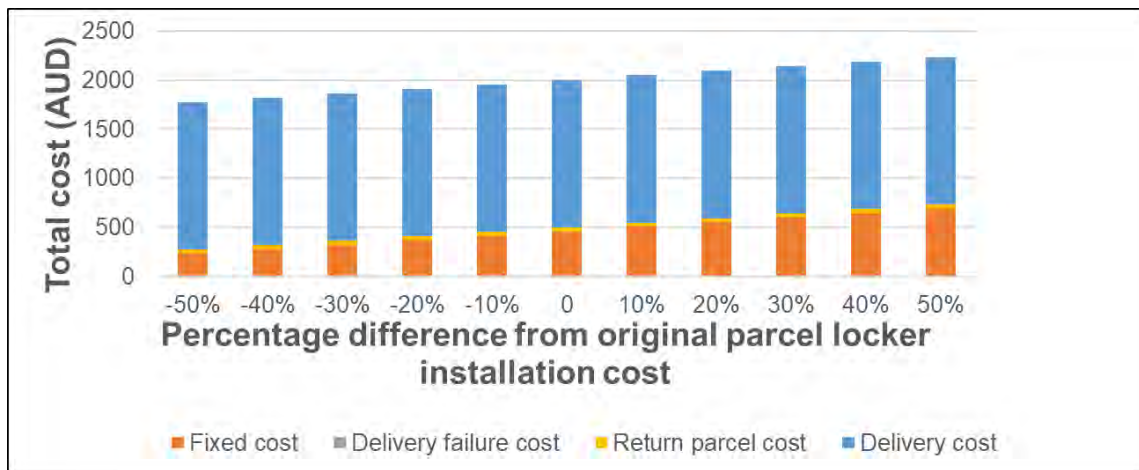

(a)

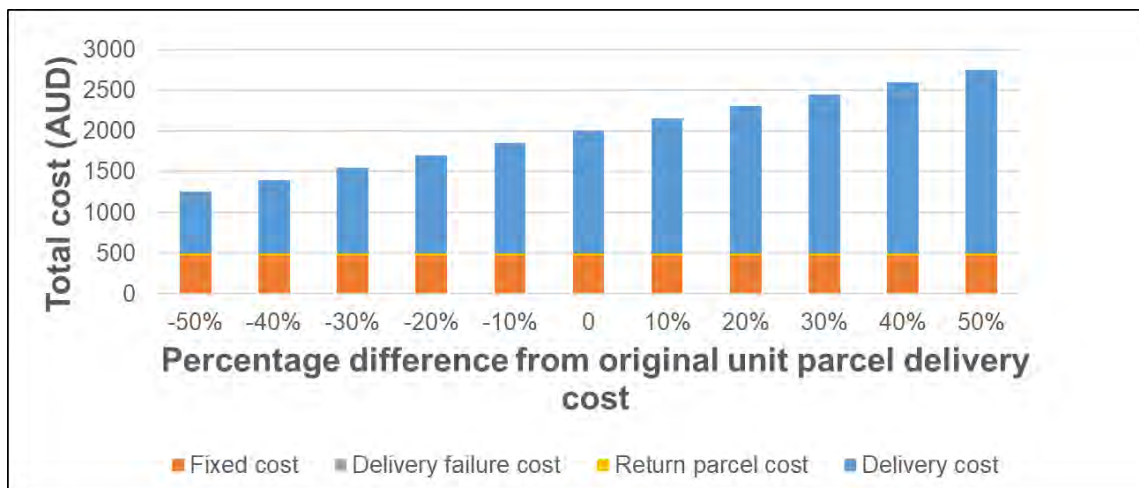

(b)

Figure 7: Cost sensitive analysis (a) Parcel installation cost (b) Unit parcel delivery cost

5 Conclusions and Future Work

Parcel lockers provide a flexible and convenient option for receiving goods ordered on-line as well as a means of reducing the logistics, social and environmental costs associated with delivering parcels in urban areas. A model has been developed for determining the optimal number of lockers to be provided at based on aggregate demand, pickup profiles as well transport and storage costs.

A number of enhancements to the model presented are planned to incorporated that will allow the effect of options including introducing penalties for not picking up parcels after 2 days, discounts for picking up parcels the day they are delivered and multiple deliveries to a locker station each day.

Future work will also consider how stochastic demand levels and pickup times can be incorporated. It is also planned to extend the model to include a network of locker stations, shared use of lockers by multiple logistics organisations as well as include multiple size lockers for handling different sized goods.

References

- Crainic, T. and B. Montreuil, (2016). Physical internet enabled Hyperconnected City Logistics, *Transportation Research, Procedia* 12, 383-398.
- de Oliveira, L.K., E. Morganti, L.Dablanc, R. Lúcia and M. de Oliveira, Analysis of the potential demand of automated delivery stations for e-commerce deliveries in Belo Horizonte, Brazil, *Research in Transportation Economics* 65 (2017) 34-43.
- Faugere, L. and B. Montreuil (2016). Hyperconnected City Logistics: Smart Lockers Terminals & Last Mile Delivery Networks, 3rd International Physical Internet Conference, Atlanta.
- Morganti, E., S. Seidel, C. Blanquart, L. Dablanc and B. Lenz, (2014). The impact of e-commerce on final deliveries: alternative parcel delivery services in France and Germany, *Transportation Research Procedia* 4, 178 – 190.
- Iwan, S., K. Kijewska and J. Lemke (2016). Analysis of parcel lockers' efficiency as the last mile delivery solution – the results of the research in Poland, *Transportation Research Procedia*, 12, 644 – 655.
- Thompson, R.G. and E. Taniguchi (2015). Future Directions, Chapter 13, in *City Logistics: Mapping the Future*, (E. Taniguchi and R.G. Thompson, Eds.), CRC Press, 201-210.



A new network concept for Logistic Centres in Hungary – regional segmentation in line with the PI vision

Florian Ehrentraut¹, Christian Landschützer¹, Telek Péter², Tamás Bányai²

1. Graz University of Technology – Institute of Logistics Engineering, Graz, Austria
 2. UNIVERSITY OF MISKOLC - Institute of Logistics, Miskolc, Hungary
- Corresponding author: florian.ehrentraut@tugraz.at

Abstract: *With the introduction of the Physical Internet (PI) a paradigm-breaking field is enabled encompassing the hyperconnectivity and interoperability of smart logistics networks, transportation systems, manufacturing systems and supply chains. During the last years the PI concept is getting more and more popular but is still mostly restricted to research, which means industry has still only minor knowledge of PI at this moment. In order to fasten the transfer of knowledge from research to industry a future PI scenario is developed focusing on a Hungarian-Austrian transport case. Based on this scenario and on a survey which investigates and evaluate technical solutions and capacities existing in Logistic, the abilities and opportunities of companies related to the introduction of a future PI network are estimated.*

Keywords: *Physical Internet, Logistic network in Hungary, Survey on logistic centres, PI Nodes, PI Hubs*

1 Introduction and objectives

Despite the efforts by logistic distributors to raise efficiency in their business, logistics across the planet is societal, environmental and economically unsustainable. Focusing on the challenges related to those unsustainability factors the Physical Internet (PI) Initiative tries to address them as an open global logistics system founded on physical, digital and operational interconnectivity through encapsulation, interfaces and protocols. The PI tries to evolve logistics around the world to be societal, environmental and economically more sustainable compared to today's logistics. (cf. Montreuil 2011; Montreuil 2013; Ballot et al. 2014)

Since the first introduction of the PI concept by Professor Benoit Montreuil and the early development together with Professors Russell D. Meller and Eric Ballot, the PI concept is getting more and more popular during the last years. But still, driving the concept is mostly restricted to research despite the efforts to include industry in the discussions and development process by e.g. the annual International Physical Internet Conference (IPIC 2018). This means industry has still only minor knowledge of PI and being confronted with the PI concept the first time a lot of uncertainty, various risks and many questions and concerns are raised (see: Cimon 2014; Ehrentraut et al. 2016). This is also true for Hungarian companies.

In order to fasten the transfer of knowledge from research to industry the research partners from the University of Miskolc - Institute of Logistics, Miskolc, Hungary (UMi) and Graz University of Technology – Institute of Logistics Engineering, Graz, Austria (TU Graz) developed a future PI scenario with special focus on future PI Hubs in an Hungarian-Austrian transport case. The research was conducted in the framework of the UMi-TWINN project which is a 3-year project under the European Union's Horizon 2020 research and innovation programme (UMi-TWINN 2018).

Starting point of the research presented in this paper is the analysis of future PI Hubs and the existing Hungarian Hub structure. As the tasks of the Hubs are usually logistic tasks, a possible solution to build Hubs for the PI network is the using of existing Logistic Centres and a network concept based on regional segmentation. In a next step this regional segmentation

will be used to develop the future PI scenario investigating a Hungarian-Austrian transport scenario. Based on a survey the presented research will furthermore investigate and evaluate technical solutions and capacities existing in Logistic Centres towards an application in future PI Hubs. The paper will be concluded with an outlook on future research towards the realisation of PI Hubs and network concepts for Logistic Centres.

2 Description of the initial situation

Following the application of the digital internet, in PI goods will be sent over an open and global logistics system founded on physical, digital and operational interconnectivity through encapsulation, interfaces and protocols. Next to operational and organizational aspects like horizontal and vertical collaboration or the sharing of information, central pillars of the PI involve also physical assets e.g. the physical encapsulation of goods in modular, standard PI Container and PI Hubs and other nodes in the network. (cf. Montreuil 2011; Montreuil 2013; Ballot et al. 2014; Landschützer et al. 2015)).

Synonymous to nodes in the Digital Internet, future PI Nodes and especially PI Hubs represent in general the transition points of a future PI network which serve as meeting, transfer and storing points within the PI activities and will handle the PI Container and route the logistic flow in the hyperconnected distribution network. In an early definition given by Montreuil et al. (2010) PI Nodes are described as locations expressly designed to perform operations on PI-Containers such as receiving, testing, moving, routing, handling, placing, storing, picking, monitoring, labeling, paneling, assembling, disassembling, folding, snapping, unsnapping, composing, decomposing and shipping PI-Containers. PI Hubs are described by Ballot et al. (2014) as nodes in the PI where PI Containers switch from one logistics service to another (e.g. gateway between two logistics networks, change of mode of transport, change of vehicle, coupling/decoupling, etc.). As this paper presents a future PI scenario with special focus on a Hungarian-Austrian transport case the focus of this research work will be on PI Hubs.

2.1 Analyzation of Physical Internet Hubs

In order to enable seamless open asset sharing and flow consolidation on a massive scale, PI Hubs need special, advanced handling equipment and handling processes. These equipment and processes used in future PI Hubs will not only be dependent on maximum throughput or storage capacity. They will also depend on the location of the PI Hub in the supply chain network and the different interfaces for multimodal transport. As the PI imposes more unloading/reloading work for transshipment, the handling equipment and handling processes used in future PI Hubs will further strongly depend on the various sizes and handling interfaces of the future PI Containers. More details on the different dependencies are as follows:

Like distribution centres today, also PI-hubs will be located in overland and suburban regions as well as in cities and according to Ballot et al. (2014) different types of PI Hubs according to the size categories will be required. Those different types are listed in Figure 1 and supposed to process different kind of PI Containers. E.g. on an urban level, the PI Container sizes will mostly be small but when it is a case of using maritime, rail or waterway corridors, only PI-Containers in the large size category will be present. Therefore, specific features and requirements will arise from the different hubs levels. Ballot et al. (2014) have further stated that additional requirements are arising from multimodal transport in the PI. The different interfaces between the modes of transportation require specific hubs to interconnect their mode-specific features in order to make multimodal freight transportation as efficient as possible.

Hub types	Ship	Train	Barge	Aircraft	Truck	Light vehicle	Manual*
Ship	L: ✓ M: ✓ S: ✓	L: ✓ M: ✓ S: ✓	L: ✓ M: ✓ S: ✓	Ø	L: ✓ M: ✓ S: ✓	Ø	Ø
Train		L: ✓ M: ✓ S: ✓	L: ✓ M: ✓ S: ✓	L: ✓ M: ✓ S: ✓	L: ✓ M: ✓ S: ✓	L: ✓ M: ✓ S: ✓	Ø
Barge			L: ✓ M: ✓ S: ✓	Ø	L: ✓ M: ✓ S: ✓	L: ✓ M: ✓ S: ✓	Ø
Aircraft				L: ✓ M: ✓ S: ✓	L: ✓ M: ✓ S: ✓	L: ✓ M: ✓ S: ✓	L: ✓ M: ✓ S: ✓
Truck				L: ✓ M: ✓ S: ✓	L: ✓ M: ✓ S: ✓	L: ✓ M: ✓ S: ✓	L: ✓ M: ✓ S: ✓
Light vehicle					L: ✓ M: ✓ S: ✓	L: ✓ M: ✓ S: ✓	L: ✓ M: ✓ S: ✓
Manual*							L: ✓ M: ✓ S: ✓

* Manual = on foot, bike, etc.

*L= PI Container of cross-section compatible with heavy means of transportation
M = PI Container of around 1 m3
S = small PI Container/box.*

Figure 1: Types of hub required between modes and according to the size categories (Ballot et al. 2014)

As stated above, PI Hubs on different levels will handle different sized PI Containers and will perform different handling activities. Montreuil et al. (2015) have further developed the modular design of PI Containers and further defined the different sizes. They follow a three-tier characterisation with Packaging containers (size S), Handling containers (size S and M), Transportation containers (size M and L) depicted in Figure 2. PI Hubs especially used for crossdocking or the change between two means of transportation will rather handle Transportation containers, but e.g. during the collection of shipments from different productions (upstream) and for distribution purpose (downstream) it will be necessary to compose or recompose Handling containers of smaller and of medium sizes and further to load and unload e.g Handling containers encapsulated in a Transportation container as depicted in Figure 3. Therefore, it is of major importance to the performance of the entire system to have hubs, handling equipment and handling processes designed especially for PI Containers of various sizes the many requirements arising from the PI.

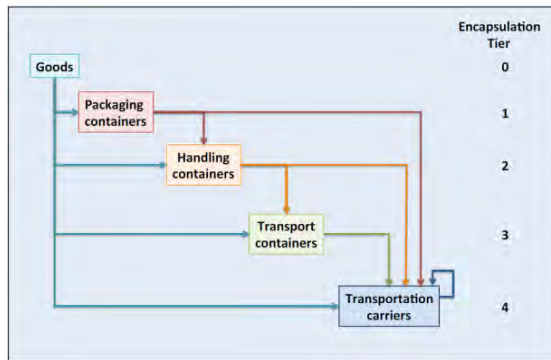

Figure 2: Proposed PI encapsulation characterization (Montreuil et al. 2015)

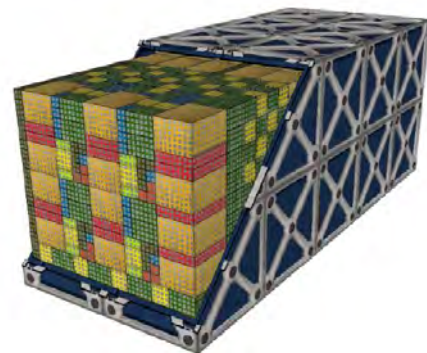

Figure 3: Handling containers encapsulated in a Transportation-container (Montreuil et al. 2015)

2.2 Functional Design and Requirements for Physical Internet Hubs

A first effort towards the functional design of PI Hubs was done by Montreuil et al. (2010), Ballot et al. (2012), Meller et al. (2012) and Montreuil et al. (2012) by focusing on a road-rail hub, a road-based transit center and a unimodal road-based crossdocking hub. Next to a conceptual design also KPIs concerning performance assessment for customers and operators are presented. Table 1 gives an overview on KPIs from a road-based transit center and a unimodal road-based crossdocking hub which were derived from the conceptual design.

Table 1: Performance assessment for PI Hubs (cf. Meller et al. 2012, Montreuil et al. 2012)

KPIs	Road-based transit centre	Unimodal road-based crossdocking hub
Area [m ²]	64.000	154.000
Number of Gates (in)	4	4
Number of Gates (out)	4	4
Number of Parking bays (trucks)	24	92
Number of Switch bays	36	-
Number of Docks	-	30
Number of PI Containers (1.2x2.4x2.4m) currently in the PI Hub (max)	-	533

Furthermore, by analysing the different processes and handling processes executed inside a PI Node with considering the system boundary beginning at the receiving area and ending at the shipping area, the following main handling processes of a PI Hub are identified base on the 3 publications mentioned above:

1. Loading and unloading external means of transport
2. Composing and decomposing
3. Sorting and conveying
4. Goods identification and management
5. Storing and buffering
6. Dispatching external means of transport

2.3 Structure of existing Logistic hubs in Hungary

The main aim of this research is to estimate the abilities and opportunities of the Hungarian companies related to the introduction of future PI networks. Starting point of the analysis is the Hub structure. As described above, the tasks of the Hubs are usually logistic tasks. Therefore, a possible solution to build Hubs for the PI network is the use of existing Logistic Centres. In Hungary, based on the data of the Association of Hungarian Logistic Service Centres (AHLSC), there are 32 Logistic Centres (16 Intermodal, 7 Regional and 9 Local Logistic Centres) in 2017 (see Figure 4).

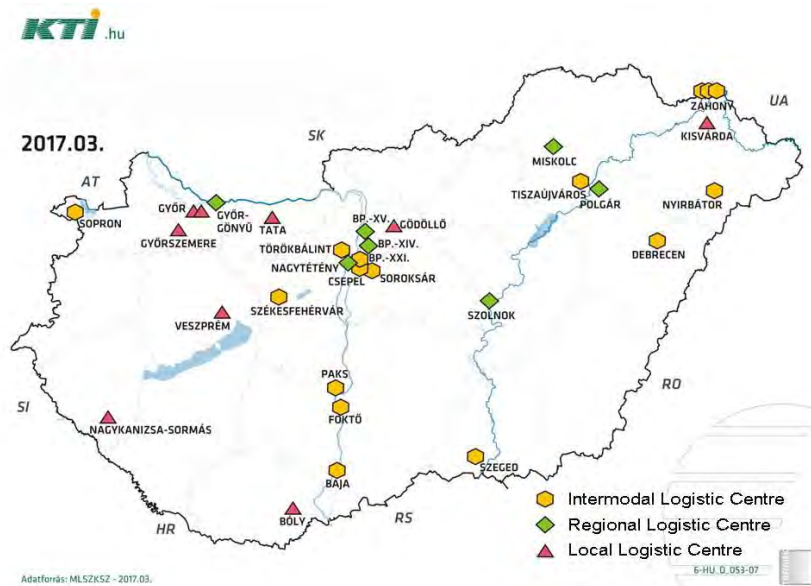

Figure 4: Logistic Centres in Hungary (KTI 2018)

Based on the locations of the Logistic Centres and the industrial environment, the Hungarian Government developed a network concept in which the country area was segmented into 11 main regions (Figure 5), where the Logistic Centres have central role in logistic aspect.

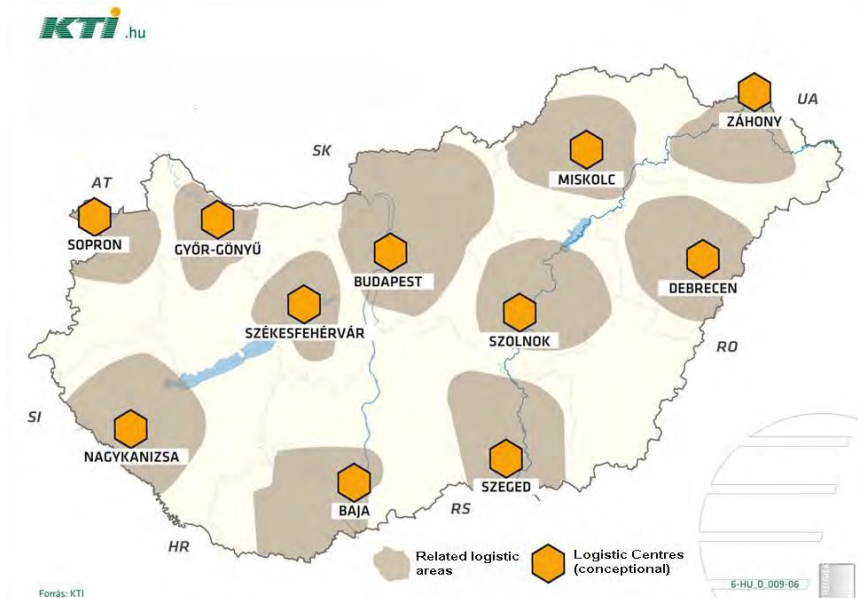

Figure 5: Logistic Centres and their related regions, source (KTI 2018)

The concept of this regional segmentation is to distribute the logistic tasks among the different Logistic Centres, supplying all of the needs in the related regions. Of course, as the PI concept tries to cover not only the industrial, but also the consumer needs, so a much more dens solution also can be taken into consideration. For this variation, higher number of Hubs has to be applied, where, for example, the Hungarian industrial parks can also be counted as possible Hubs. In 2016, based on the data of the Institute of Traffic Researches (KTI), there were near 200 industrial parks in Hungary (see Figure 6).

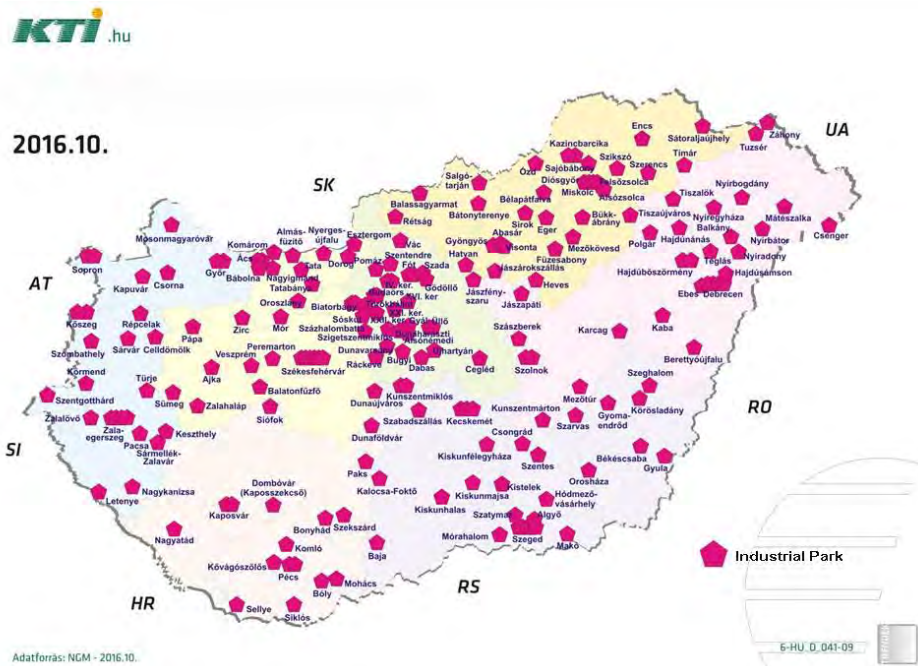

Figure 6: Industrial Parks in Hungary (KTI 2018)

3 PI scenario for Hungary and Austria

As mentioned in chapter 1 the PI concept is getting more and more popular during the last years. But still, industry has only minor knowledge of PI and being confronted with the PI concept the first time raises uncertainty and in some cases also false perceptions and ideas. As this is also true for Hungarian companies a future PI scenario investigating a Hungarian-Austrian transport case is developed following the approach of Montreuil B. (2014) who presented a multi-segment travel from Québec to Los Angeles in the Physical Internet Manifesto to push forward the PI in North America and show the development from point-to-point hub-and-spoke transport to distributed multimodal transport.

Building on the regional segmentation depicted in Figure 5 a transport scenario between Miskolc (Hungary) and Graz (Austria) is developed which is depicted in Figure 7. The route chosen for this transport scenario is derived and shown with the rout planning system of the Austrian automobile, motorbike and touring club - ÖAMTC (ÖAMTC 2018). Boundary conditions and simplifications for the transportation scenario are based on the regulation EU VO 561/2006 (WKO 2008) and are as follows:

- 9h total driving time per day
- 45min break after 4.5h of driving time
- 9h continuous rest time per day

Further boundary conditions are:

- Average speed: 80 km/h
- Truck driving distance for 4h: 320km
- ban on night journeys is not taken into account
- PI Hubs are located in a 4h driving distance
- The total time at a PI Hub (transit point) to e.g. change truck or process the shipment is estimated with 30min based on the findings of Meller et al. (2012)

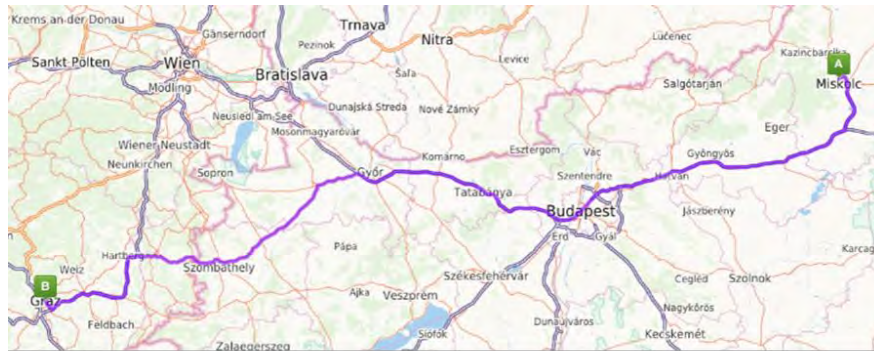

Miskolc-Graz		
	Current	PI
Distance travelled one-way [km]	552	555
Drivers	1	2
Trucks	1	2
Trailer	1	1
Total time at transit points [h]	0,0	0,5
One-way driving time [h]	6,9	6,9
Average driving time per driver [h]	13,8	6,9
Average trip time per driver [h]	23,3	7,4
One way total trailer trip time [h]	7,7	7,5

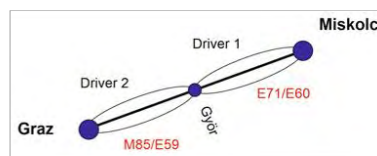
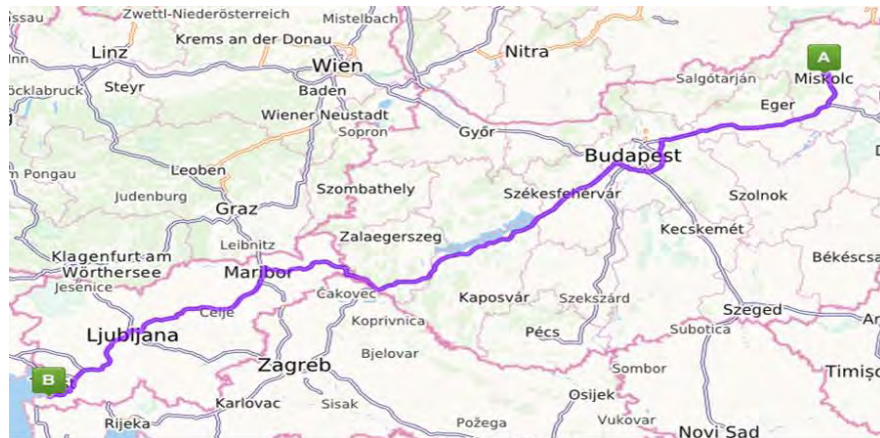

Figure 7: Transportation scenario from Miskolc to Graz

Due to the short distance travelled between Miskolc and Graz only a marginal difference concerning the one-way total trailer trip time between the current situation and a future PI can be recognized. A larger difference can be recognized in the average driving and trip time per driver. As the PI also intends to make the current logistic system societal more sustainable this is an important factor. Driver 1 is having the possibility to go to and fro between the PI Hubs in Miskolc and Győr in one day (Győr was selected for this transportation case in reference to the regional segmentation depicted in Figure 5). The same is valid for Driver 2 who goes to and fro between the PI Hubs in Győr and Graz.

In a second transport case depicted in Figure 8 between Miskolc (Hungary) and Koper (Slovenia) the difference concerning the one-way total trailer trip time between the current situation and a future PI is already significant. For this transportation case a PI Hub in Székesfehérvár and Maribor is assumed, the route is again derived and shown with the rout planning system of ÖAMTC (ÖAMTC 2018) and the above listed boundary conditions and simplifications are again taken into account.



Miskolc-Koper		
	Current	PI
Distance travelled one-way [km]	771	854
Drivers	1	3
Trucks	1	3
Trailer	1	1
Total time at transit points [h]	0	1
One-way driving time [h]	9,6	7,3
Average driving time per driver [h]	19,3	7,1
Average trip time per driver [h]	38,8	7,6
One way total trailer trip time [h]	19,4	11,7

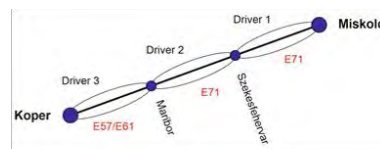

Figure 8: Transportation scenario from Miskolc to Koper

Due to the larger distance between Miskolc and Koper a significant difference concerning the one-way total trailer trip time between the current situation and a future PI can be recognized compared to the first transportation scenario from Miskolc to Graz. Even a larger difference can be recognized in the average driving and trip time per driver. The current average trip time per driver is 38.8h whereas the average driving time for Driver 1, 2 and 3 in a future PI would be 7.1h which means the drivers in a future PI will have the possibility to go to and fro between the PI Hubs in one day.

In the above presented transport scenarios the focus is on the possible impact of the PI on the trip time for trailer and driver. In order to estimate the impact of the PI on a network and more technical level, technical solutions and capacities of existing Logistic Centres in Hungary are evaluated in the next chapter.

4 Evaluation of existing hubs in Hungary

In chapter 3 the rather theoretical transport scenarios already showed the possible impact of the PI regarding trip time for trailer and driver. In order to realize those scenarios many building blocks have to come in place. Next to a further development of modular PI containers, standard protocols and the willingness of supply chain participants to contribute to the PI, the further development of PI Hubs is of major importance. To estimate the abilities and opportunities of Hungarian companies towards an application of future PI Hubs, another important question is what kind of technical solutions and capacities exist in the Logistic Centres in Hungary today.

The Association of Hungarian Logistic Service Centres - AHLSC designed a survey to collect information on existing logistic centres in Hungary (AHLSC 2016). The survey will be the base for the estimation of abilities and opportunities. It was designed around two primary objectives:

- Collecting appropriate data to identify and quantify logistic service centres in Hungary; and
- Identifying strengths, weaknesses, opportunities and threads of them.

To provide an overview of the Hungarian logistic landscape the following main parameters can be presented:

- number of joined logistic centres: 70;
- annual revenue: 108 billion EURO;
- number of employees: 7400;
- area of properties: 1000 ha;
- area of normal warehouses: 777.000 m²
- cargo traffic: 415.000 TEU
- free land storage area: 1.000.034 m²
- tempered warehouse area: 267.000 m²
- cold store area: 18.143 m²
- capacity of silos: 57.073 m³
- cargo store capacity: 19.465 TEU

There are 70 logistic centres joined to the AHLSC, the presented survey (AHLSC 2016) includes 22 logistic centres. In the following subchapters the most important results of the survey are presented and discussed.

4.1 Survey results regarding the area and parking places of logistic centers:

The results regarding the area of the 22 different logistic centers participated in the survey is presented in Figure 9 and ranges from 0m² up to 700,000m².

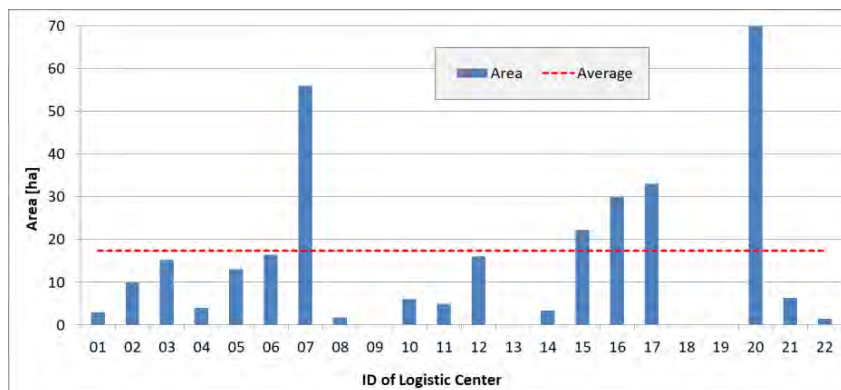

Figure 9: Distribution of area of logistic centers

In a futur PI network, PI Hubs of different sizes depending of their location and function will exist. The area presentet as a KPI in Table 1 ranges from 64,000m² to 154,000m², therefor the average area of 180,000 m² derived from the participating logistic centers in the survey would meet the requirements to establish a future PI Hub.

Included in the area of the logistic centers is space for parking places of trucks and cars. The results from the survey are as follows:

- Number of parking places for trucks range from 0 to 125. The average is 41 parking places.
- Number of parking places for cars range from 0 to 230. The average is 60 parking places.

As stated above, different sized PI Hubs will exist in a future PI network. KPIs regarding partking bays for trucks presented in Table 1 range from 24 to 92. Therefore the average of 41 parking places for trucks would only partly meet the requirements to establish a future PI Hub. Regarding the presented figures on parking places for cars it is important to keep in mind that PI Hubs will also have different functions. E.g. a PI Hub functionig as a city hub will need to distribute the shippments arriving in from other Hubs towards the city or will have to consolidate shipments from the city to distant destinations. Therefore enought parking places for vans to bridge waiting time is needed. Considering a frequence of 10 trucks per hour each loaded with 34 PI containers of the size 0.8x1.2x2.4m and estimating a capacity of 1 to 4 PI containers of the size 0.8x1.2x2.4m per city van this would equal to 340 or 85 vans per hour.

4.2 Survey results regarding the services offered by logistic centers

The results regarding the services provided by paticipants of the survey is depicted in Figure 10. Typical additional services offerd by the 22 paricipating logistic centers are presented in Table 2.

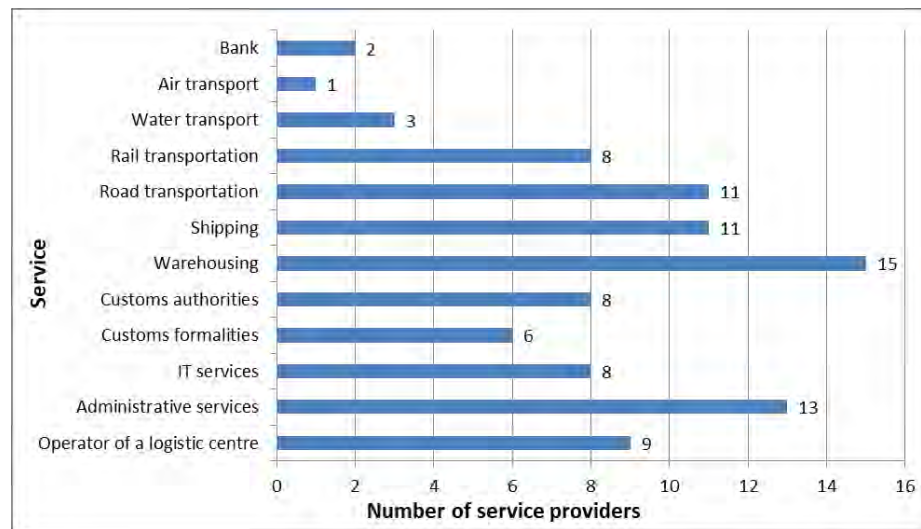

Figure 10: Number of service providers

Towards the imlementation of a future PI network, imortant services are the different modes of transportation e.g. rail and road, the possibility to store shipments in attached warehouses or PI Stores, to provid IT services in order to guarantee full interconnection, the transhipment from containers to trucks or crossdocking. Considering an additional result of the survey whereupon some of the participating logistic centers offer no service at all or only little service and the results shown in Table 2 conserning the transhipment from containers to trucks or crossdocking the current logistic centers would not meet the requirements to establish a future PI Hub.

Table 2: Typical additional services

ID	Packaging	Transpacking	Selective packing	Labelling	Trans-shipment from container to trucks	Order picking	Crossdocking
01	X	X	X				
02	X	X	X				
03							
04	X	X	X	X			
05	X	X	X				
06							
07	X						
08	X	X	X				
09		X					
10	X	X	X				
11	X	X	X				
12					X		
13							
14	X	X	X	X		X	
15							X
16							
17							
18	X	X					
19							
20	X	X	X				
21							
22	X	X	X			X	

4.3 Survey results regarding the storage area offered by logistic centers

The results regarding the storage area provided by participants of the survey is depicted in Figure 11. The results range from 0m² to 170,000m² and the average are of normal storage is around 20,000m².

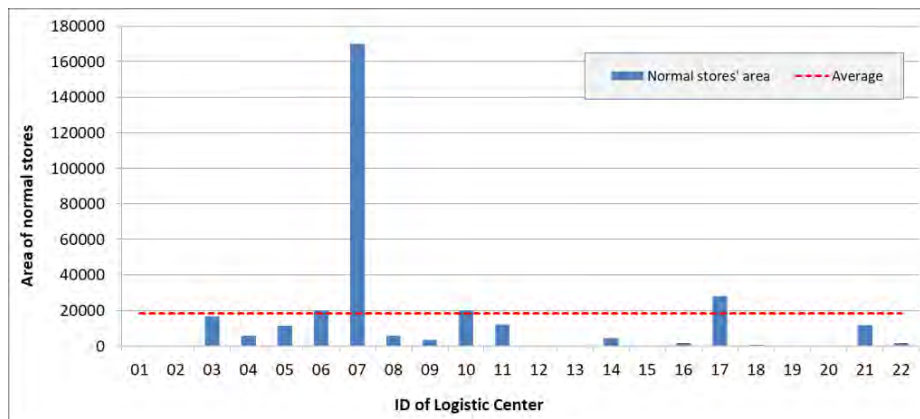

Figure 11. Area of normal stores

As producers and shippers will have the possibility to store their products close to the point of consumption by using the future PI, storage area provided by PI Hubs depending on their size and function plays an important role. In contrary to the current system, tempered or cold storage would not be needed any more as the modular PI container can be equipped with a cooling module.

4.4 Survey results regarding the handling capabilities offered by logistic centers

The results regarding the handling capabilities by participants of the survey are depicted in Figure 12 and Figure 13.

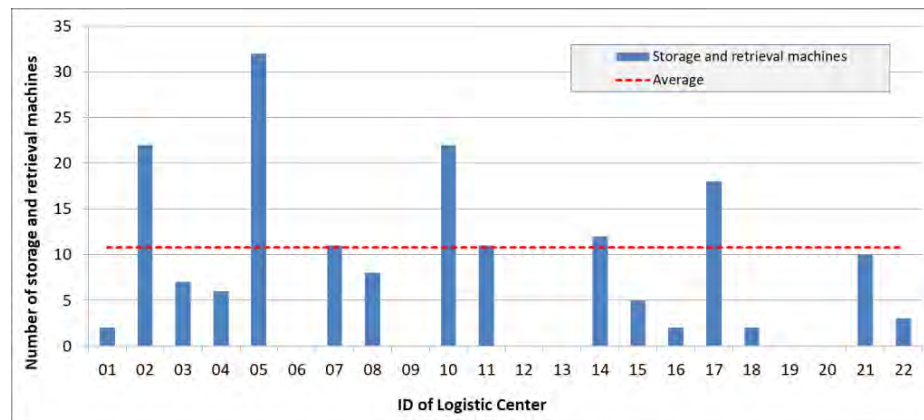

Figure 12: Number of storage and retrieval machines

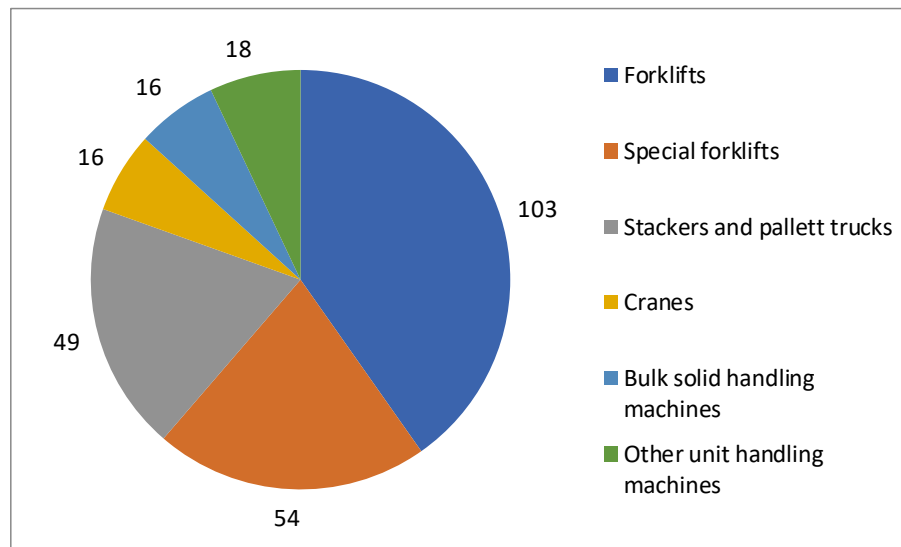

Figure 13: Types and distribution of the loading machines

In order to meet the efficiency needed in future PI Hubs, the level of automation needs to be high regardless the size or function of the PI Hubs. In contrary to the current logistic system, crossdocking and sorting operations will rise as a result of multi-segment travel and the used PI Containers. Furthermore, the use of forklifts and handling equipment able to handle PI containers will be necessary.

5 Conclusion and outlook

The presented research in this paper dealt with the analysis of future PI Hubs and the existing Hungarian Hub structure. A regional segmentation of logistic centres in Hungary was used to develop the future PI scenario investigating a Hungarian-Austrian transport scenario. Based on a survey the presented research furthermore investigated and discussed technical solutions and capacities existing in Logistic Centres towards an application in future PI Hubs. This paper will now close with a conclusion and an outlook.

Even as the presented transportation scenarios are only short distance, one can already see the advantages in terms of the one-way total trailer trip time between the current situation and a future PI. Another important factor are the social improvements for truck drivers offered by a future PI. As logistic service providers face a lack of qualified drivers, the possibility of returning each evening to the same place can help to make the job as truck driver more attractive.

Concluding on the evaluation of currently existing hubs it can be stated that even though part of the system requirements to fulfil the main handling process of a PI Hub presented in chapter 2.2 already exist to some extent in present Hungarian hubs, there is one major concern affecting many of the necessary developments towards a future PI: The modular PI Container. Nowadays, most of the material handling systems are designed for pallet handling operations and there is no need for adapting or replacing the standard systems towards a palletless handling system like intended in the PI so far. Gabernig and Ehrentraut (2018) describe the mutual influence between the PI-container development and the development of matching material handling systems for the PI as inevitable, not least because of the amount of handling systems which the PI-container will be eventually handled with. As illustrated in Figure 14 the PI requirements are also influencing the development of PI Containers and corresponding material handling systems.

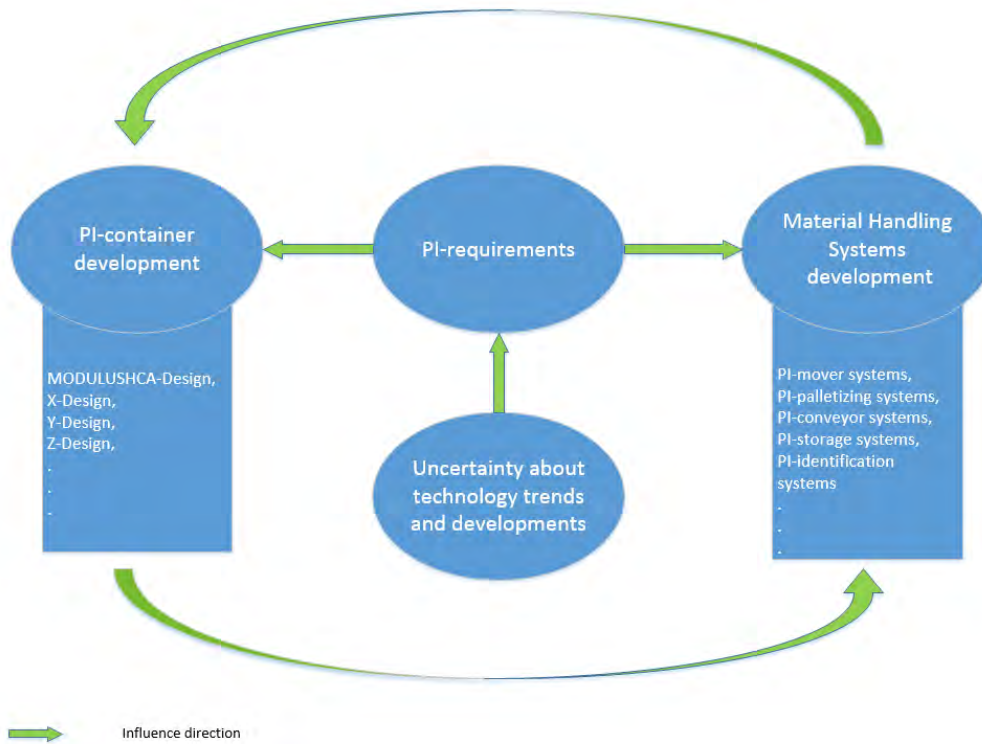

Figure 14: Influence of PI-requirements, PI-container development and material handling systems development (Gabernig and Ehrentraut 2018)

As stated in chapter 2.1 there will be different types of PI Hubs with different functions and due to the location of the PI Hub with different sizes regarding handling capacity, storage capacity or throughput. In order to further assess the abilities and opportunities for Hungarian companies towards a future PI a more detailed investigation is needed. A next step is to determine an expected shipping volume for a future PI Hub based on the structure for regional Logistic Centres introduced in Figure 5 and on the shipping volume of the current logistics centres. Based on the determined shipping volume and on KPIs of today used handling technology, gaps concerning the technical requirements can be distinguished.

References

AHLSC (2018): Association of Hungarian Logistic Service Centers (AHLSC) - survey results 2016-2017.

- Ballot, E.; Montreuil, B.; and Thivierge, C. (2012); Functional Design of Physical Internet Facilities: A Road-rail Hub. In: 12th IMHRC Proceedings (Gardanne, France – 2012). 13.
- Ballot E., Montreuil B., Meller R.D. (2014): The Physical Internet- the network of logistics networks, La documentation Francaise/Predit, Paris.
- Cimon Y. (2014): Implementing the Physical Internet real-world interfaces: Beyond business models, the devil is in the details, In: 1st International Physical Internet Conference, Québec City.
- Ehrentraut, F., Landschützer, C., Graf, H-C., Gasperlmaier, A. & Hörtenhuber, S-T.: Go2PI: Practically proved steps to implement the Physical Internet. In: 3rd International Physical Internet Conference 2016, Atlanta USA.
- Gabernig H., Ehrentraut F. (in print 2018): Material Handling Systems for Physical Internet Hubs – Evaluation and readiness of present Material Handling Systems for the Physical Internet, In: 5th International Physical Internet Conference, Groningen.
- GKM 1(998): GKM -Ministry of Economy and Traffic of Hungary, www.gkm.hu, 1998.
- IPIC (2018): International Physical Internet Conference, <https://www.pi.events/>, 25.04.2018.
- KTI 2018: Institute of Traffic Researches (KTI), Ipari Parkok Magyarországon 2017.03, <http://www.kti.hu/index.php?mact=Album,m5,default,1&m5albumid=370&m5page=4&m5returnid=760#link> , 25.04.2018.
- Landschützer C., Ehrentraut F., Jodin D. (2015): Containers for the Physical Internet: requirements and engineering design related to FMCG logistics, In: Logistic Research (2015). DOI 10.1007/s12159-015-0126-3.
- Meller, R.D.; Montreuil, B.; Thivierge, C.; and Montreuil, Z. (2012): Functional Design of Physical Internet Facilities: A Road-based Transit Center. In: 12th IMHRC Proceedings (Gardanne, France – 2012). 26.
- Montreuil B., Meller R.D.; Ballot E. (2010): Towards a Physical Internet: The Impact on logistics Facilities and material handling system design and innovation. In: Kimberly E. et al. (ed.) (2010): Progress in material handling research: 2010: [based upon invited papers submitted for the 11th International Material Handling Research Colloquium (IMHRC) held in Milwaukee, WI, USA, 21 - 24 June 2010]. Charlotte, NC : Material Handling Institute, 2010, page 305–327.
- Montreuil B. (2011): Towards a Physical Internet: Meeting the Global Logistics Sustainability Grand Challenge, Logistics Research, v3, no2-3, 71-87.
- Montreuil, B.; Meller, R.D.; Thivierge, C.; and Montreuil, Z. (2012): Functional Design of Physical Internet Facilities: A Unimodal Road-Based Crossdocking hub. In: 12th IMHRC Proceedings (Gardanne, France – 2012).
- Montreuil B. (2014): Physical Internet Manifesto, v1.10, (Original v1.0, 2009), www.physicalinternetinitiative.org, 2014/02/20.
- Montreuil B, Ballot E, Tremblay W (2015): Modular Design of Physical Internet Transport, Handling and Packaging Containers. In: Smith et al (ed.) (2015): Progress in material handling research 2015. Material Handling Industry of America, Charlotte, NC, USA.
- ÖAMTC – Österreichischer Automobil-, Motorrad- und Touring Club (Austrian automobile, motorbike and touring club): Routenplaner. <https://www.oeamtc.at/routenplaner/>, 25.04.2018.
- UMi-TWINN (2018): Reinforce the scientific excellence and innovation capacity in logistic technology of the University of Miskolc (UMi), <https://www.umi-twinn.com/>, 25.04.2018.
- WKO - Wirtschaftskammer Österreich (Austrian Federal Economic Chamber): Arbeitszeittabelle: Lenkzeiten.https://www.wko.at/branchen/transport-verkehr/gueterbefoerderungsgewerbe/Arbeitszeittabelle_Lenkzeiten.html, 25.04.2018.

Physical Internet enabled bulky goods urban delivery system: a case study in customized furniture industry

Hao Luo¹, Siyu Tian¹, Xiang T.R. Kong^{1,2}

1. Department of Transportation Economics and Logistics Management, College of Economics Shenzhen University, Shenzhen, PR China

2. Department of Industrial and Manufacturing Systems Engineering, The University of Hong Kong, Hong Kong

Corresponding author: Hao Luo address email: luohao403@gmail.com

Abstract: *Physical Internet (PI) is a novel concept aiming to render more economically, environmentally and socially efficient and sustainable the way, in which physical objects are transported, handled, stored, realized, supplied and used throughout the world. In this paper, the application scope of PI is scaled down into a city-wide and the urban delivery system for bulky goods is investigated. The bulky goods include household electrical appliances, musical instruments and indoor decorating materials. Customized furniture is one of the typical bulky goods. Some characteristics of customized furniture delivery bring critical challenges to the logistics service providers. The furniture delivery operator not only needs to transport the goods to the customer destination, but also needs to carry the goods into the customer's house. There is no suitable material handling facility for their on-site operation. The truck unloading and in-house movement is very time consuming and leads to extremity high labor cost. The "last 100 meters" becomes the critical bottleneck of furniture delivery industry. In order to solve these problems, the concept of Physical Internet has been employed and a PI enabled bulky goods urban delivery system is proposed. In the proposed system, a modularized furniture container as well as a vehicle-mounted container loading/unloading facility is designed. These facilities are accompanied by a mobile execution system for drivers and a real time task planning system for high level resource control. The feasibility of the proposed system is illustrated in a real-life case study in a leading customized furniture company in China.*

Keywords: *Physical Internet; modularized cabinet; bulky good; urban delivery; transportation facility; operation mechanism*

1 Introduction

Physical Internet (PI) is a novel concept aiming to render more economically, environmentally and socially efficient and sustainable the way in which physical objects are transported, handled, stored, realized, supplied and used throughout the world (Hakimi et al. 2012). It tries to evolve logistics around the world to be more social, environmental and economical compared to today's logistics. Following the application of the digital internet, PI goods will be sent over an open and global logistics system founded on physical, digital and operational interconnectivity through encapsulation, interfaces and protocols.

The majority of existing research and development of Physical Internet focus on the seamless open asset sharing and flow consolidation on a massive scale. The fundamental facility design (Montreuil 2010), functional designs (Ballot, et al. 2012) and simulations of PI (Pan et al. 2015 b) have been proposed. In such supply chain and global transportation dimension, the effectiveness and efficiency of PI has been proved in concept. The aim of PI is to enable an efficient and sustainable logistics web at the logistics hubs as well as at the end consumer

(Montreuil, 2011). To achieve this goal, Sallez et al. (2016) have shown that considerable gains can be achieved through the application of the PI by designing PI-containers. The containers have associated activity, which allows the PI-container to have an active role for its mission and in the PI management and operation. Rougès et al. (2014) examine 18 startups' available public documentation in the industry to contribute toward gaining a better understanding of stakeholder value creation, then they apply the PI concept (mobility web) to solving the limitations of crowdsourced delivery (point-to-point deliveries and processing of parcels by individuals). However, the implementation of Physical Internet is not an easy task. A mature PI system may involve multiple stakeholders and huge investments in infrastructure are required.

In this paper, the bulky goods delivery industry is investigated. The bulky goods include furniture, household electrical appliances, musical instruments and indoor decorating materials. This research has been motivated by real-life problem faced by our collaborating company, which is specialized in customized furniture. Following these characteristics of customized furniture industry is a big challenge to the delivery service providers of customized furniture. (1) One shipment order contains multiple product pieces. The loading/unloading and movement into customers house is very time consuming. (2) The long on-site material handling time leads to long waiting time of vehicles. The transportation efficiency is very low. (3) The dimensions of furniture parts are irregular. The space utilization of vehicles is very low. (4) The repeatedly loading and unloading operation may lead to product damage. Since the furniture is customized, one piece of furniture part damage may lead to a delay of the whole assembly project. Meanwhile, the remanufacturing cost is very high.

In order to solve these problems, a framework of Physical Internet enabled bulky goods urban delivery system is proposed. The key concepts of PI will be applied in this framework to design the modularized container, vehicle-mounted loading/unloading facility, mobile task execution system and real time task planning system.

The aim of this paper is: (1) to study the bulky goods delivery industry and identify the key problems, (2) to propose a Physical Internet enabled solution framework to solve the industry problem, (3) to conceptually design the key components of the proposed framework, and (4) to conduct a case study to illustrate the feasibility of the proposed solution.

The rest of this paper is organized as follows. Section 2, we review the development of Physical Internet and the previous research of urban delivery. In Section 3, authors discuss these characteristics and numerous pain points in bulky goods urban delivery. The bulky goods include household electrical appliances, musical instruments and indoor decorating materials. Customized furniture is one of the typical bulky goods. Some characteristics of customized furniture delivery bring critical challenges to the logistics service providers. Section 4, in order to solve the problem of bulky goods in urban delivery, especially the pain points identified in customized furniture industry, a PI enabled Bulky Goods Delivery System (PI-BGDS) is designed. To clarify PI-BGDS design further, we describe four aspects about it, including these designs of PI enabled container, PI enabled vehicle, a mobile task execution system and a real time resource planning system. Section 5 is a real-life case of a customized furniture industry in China, which demonstrates the efficiency and feasibility of the proposed system. The case study in this section consists of two parts. The first one is operational feasibility to show the efficiency of propose PI-BGDS. The second one is the economic feasibility to analyze the return on investment (ROI) of PI-BGDS implementation. The final part discusses the conclusion and outlook.

2 Literature review

In this section, the key projects of the PI, such as Modulushca project (modular logistics units in shared co-modal networks), the implementations of PI in real-life industry as well as the PI applications related to urban delivery are reviewed.

2.1 Physical Internet

The Physical Internet is an application of the Internet Thing (Gubbi et al. 2013), it promotes the creation of delivery channels for innovative services, whether in data exchange or logistics, which is usually included in the term Internet of Services (Schroth et al. 2007). The way PI achieves its goal is the metaphor and concept of the digital Internet to the shipping process of the real world, in which the physical container is regarded as an internet packet (Montreuil, 2011). The Modulushca project, which is the pioneer project of PI, was funded by the 7th Framework Program of the European commission. The goal of the project is to enable operations with developed iso-modular logistics, which is modularized in sizes adequate for real modal and co-modal flows of fast-moving consumer goods (FMCG). Lin et al. (2014) introduces a mathematical model to select a requisite number of modular containers to pack a set of products in order to maximize space utilization. The proposed decomposition approach provides the optimal solution of assigning modular containers with products. The results indicate that using standardized modular containers can increase the space utilization at unit load level.

For further elaboration and potential assessment of PI concept, there are two main streams in the literature. One is the methodology design for applying the PI concept in logistics network planning and decision making. Another is the functional design for the key PI components. Zhang et al. (2016) are interested in how smart box can improve product service systems by designing a cloud logistics platform to optimize a real-time information-driven logistics task. The information is sent to the platform, where is the optimized decision for distribution planning. Within the spectrum of hyperconnected city logistics, Mohamed et al. (2017) explore the operational urban transportation problem of PI containers under interconnected city logistics(ICL) considerations, in which goods in a container can be routed for transportation optimization. They provide modelling and solution approaches, and prove that the proposed solution may reduce total transportation cost in city logistics.

The implementation of the Physical Internet cannot be realized without the widespread participation of the industry. Luo et al. (2016) investigate the synchronized production-logistics decision and the execution problem under a make-to-order(MTO) chemical industry, some core concepts of the PI are illustrated by a real-life case cross-docking synchronization. Ma et al. (2017) aim to examine how the Norwegian aquaculture industry can make use of aspects within the Internet of Things and Physical Internet in order to reduce the transportation cost and time. This can be accomplished by utilizing smart modular π -containers, an open and interconnected logistics network, as well as enabling more intermodal transportation. Zhong et al. (2017) provided a demonstrative system, which contemplates the PI application for improving the manufacturing shop floor logistics. Lin et al. (2016) use the proposed Physical Internet platform to be reduced operational costs and improve efficiency in solar cell industry. Then they present a case study of implementing several platforms to solve cells sorting and product information problems in the solar cell industry.

2.2 Urban Delivery

Previous researcher indicated that Physical Internet can improve the efficiency of urban delivery. Crainic and Montreuil (2016) introduced fundamental concepts of City Logistics and Physical Internet to make up a rich framework for designing efficient and sustainable urban logistics and transportation systems.

Some facility-design research papers in the urban delivery focus on designing transport facilities and study how PI can improve goods distribution efficiency. Physical Internet facilities and material handling systems design has been addressed first by Montreuil et al. (2010). Ballot et al. (2014), Meller et al. (2014) and Montreuil et al. (2014) focus on road-rail bimodal hubs, semi-trailer transit centers and road-based cross-docking hubs. Pan et al. (2015 b) conducted a simulation for an interconnected city logistics scenario, in which taxi fleets collect e-commerce reverse flows in China, inspired by the concepts of crowd sourcing and the Physical Internet. They use open databases of taxi GPS traces and locations of shops in a large city in China for investigating the feasibility and viability of the solution proposed.

Some research papers in the urban delivery focus on route optimization of transportation. Sarraj et al. (2014) introduced protocols for PI transportation. Salles et al. (2015) addressed container routing in a PI cross-docking hub. Xu et al. (2013) proposed a mechanism design model for transportation service procurement. Pan et al. (2017) proposed a dynamic pricing optimization model for transportation service providers in PI. Chen et al. (2016) provided a PI-inspired crowdsourcing solution for collecting citywide E-commerce reverse flows. Faure et al. (2014) focus on the ex ante sustainability assessment of city logistics solutions.

Based on the above in a brief literature review, we found that the majority of existing research and development of Physical Internet focus on the solution research, π -container design and application in a real-life industry. Furthermore, in urban delivery, the effectiveness and efficiency of PI can be proved in concept. However, to the best of our knowledge, few studies have explored the special characteristics and the requirements of bulky goods delivery. Based on fruitful results of previous research on PI, the key concepts of PI have great potential, which can be applied in bulky goods urban delivery to solve the real-life problem.

3 Characteristics and Pain Points of Bulky Goods Urban Delivery

The bulky goods in urban delivery includes furniture, household electrical appliances, musical instruments and indoor decorating materials. Achieving sustainable bulky goods urban delivery has become a challenging task for logistics service providers. In the traditional transportation model, the cost of bulky goods delivery is very high.

Currently, the requirements of bulky goods home delivery activities increase sharply due to the explosion of ecommerce and online shopping. In order to boost the profile and market share, the 3rd party logistics companies provide more and more value adding services during their delivery activities. For example, the installation service and replacement service. The logistics company not only needs more delivery vehicles with larger capacity, but also needs professional personnel to do the material loading/unloading and movement operation. In this situation, the operation cost increases sharply and all logistics service participants fall into the embarrassing situation of “service war”. How to optimize the consumer’s “last 100 m” shopping experience, reduce the damage and ensure the on-time distribution, are critical issues of bulky goods urban delivery. Special Requirements of Customized Furniture Industry.

Furniture is one of the typical products in bulky goods delivery. With the upgrading of consumption structure and the O2O commercial technology, customers are not satisfied with a standardized product. They are willing to participate in the design and manufacturing process. Furniture customization industry is growing as more and more promising one.

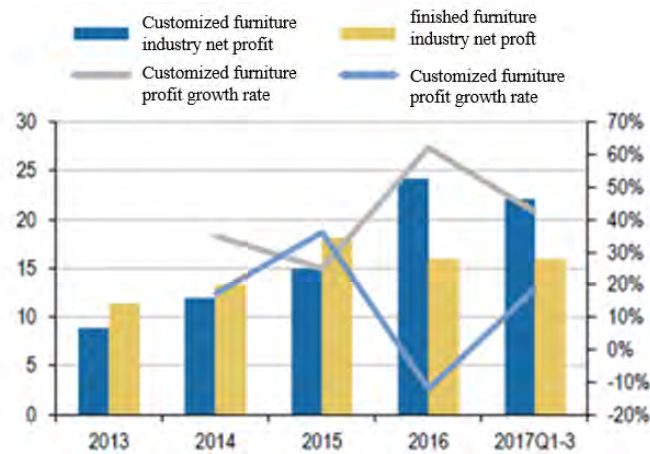

Figure 1: Comparing the accumulated net profit (100 million RMB) and growth rate of customized and finished furniture in China
Source: <http://www.chyxx.com>

3.1 Characteristics of Customized Furniture Delivery

Customized furniture is one of the typical bulky goods. Some characteristics of customized furniture delivery bring critical challenges to the logistics service providers. Compared to the traditional furniture industry, customized furniture industry has following characteristics:

- (1) Order size is quite different. Due to the different sizes of the customers' rooms, the quantity of products contained in each order is different.
- (2) Most of the product form is board-shape furniture components and a large number of metal accessories.
- (3) All components are make-to-order produced, and the customized furniture produces only one single piece.
- (4) Leading time is very long, usually more than 3 months, so it is impossible to predict the delivery time required by the customer when ordering. It is impossible to predict the delivery time required by customers when ordering.
- (5) The delivery time window is narrow. There are only two days from the customer's delivery request to the actual delivery request.
- (6) Deliver to a designated location. The customer requires all products to be moved to the designated location in the room.

3.2 Pain Points of Customized Furniture Delivery

Most of the customized furniture manufactures use the 3rd party logistics service to conduct the door to door delivery service. However, the characteristics of customized furniture industry are critical challenges for the delivery service providers.

3.2.1 Heavy workload of material handling

In order to save costs and improve efficiency, 3LP usually adopts milk run method to deliver furniture. That is, products with multiple customer orders are loaded into one car and shipped in sequence within one shipment. Because each customized furniture order consists of several components, each of which is loaded in a decentralized state. When the vehicle arrives at a distribution point, the driver needs to use the components one by one and piece by piece, which takes a lot of time. While in the process of unloading, the vehicle cannot be moved, other customers' orders are in a waiting state, and the transportation efficiency is low.

3.2.2 Unclear responsibility for operators

In the Customized furniture Delivery task, it is not only necessary to send indicated destination to indicated destination, but also to move the goods to the room as required by the customer. However, the transportation process is often difficult due to the restrictions of the conditions. For example, parking is too far away from the elevator, or moving goods upstairs for safety reasons requires taking the stairs instead of the elevator. Such handling should have been done by the professional material handling operator, but due to the lack of personnel scheduling system, the handling work was all done by truck drivers, which caused a huge workload.

3.2.3 High risk of product damage

Currently Customized furniture Delivery task requires each component to be transported multiple times: binning and picking operation in warehouse, loading operation on shipping dock, unloading operation in customer's destination, and in-door movement. And the operation process is completed in the form of scattered pieces, which is easy to cause damage. Due to these customized furniture industry features, there is only one component in each component. Once the damage is caused and the factory needs a long time to reinstall the production, serious delay will be caused for the entire order assembly and installation.

3.2.4 Complicated human and vehicle resource planning

Customers have very strict requirements on on-time delivery, the given time window is very narrow, and the delivery time often changes dynamically. When at the same time considering time, path, goods quantity, packing space constraints, such as the vehicle, personnel and other resources for effective scheduling, management, how to order for multiple concurrent (parallel order) is an important challenge.

4 PI enabled Bulky Goods Urban Delivery

In order to solve the problem of bulky goods in urban delivery, especially the pain points identified in customized furniture industry, a PI enabled Bulky Goods Delivery System (PI-BGDS) is designed. Figure 2 shows the framework of the proposed PI-BGDS, which consists of 4 function layers: PI enabled container, PI enabled Vehicle, Mobil Task Execution System and Real-time resource planning system. The design of PI-BGDS is driven by several key PI concepts, including hyperconnected city logistics (Crainic and Montreuil 2016), design of standard container size (Lin et al. 2014, Ellis et al. 2014) and PI-hub (Furtado et al. 2013). The development of 4 function layers is supported by specific IT (IoT, LBS, Mobility App) and OR (Routing planning, resource optimization) technologies.

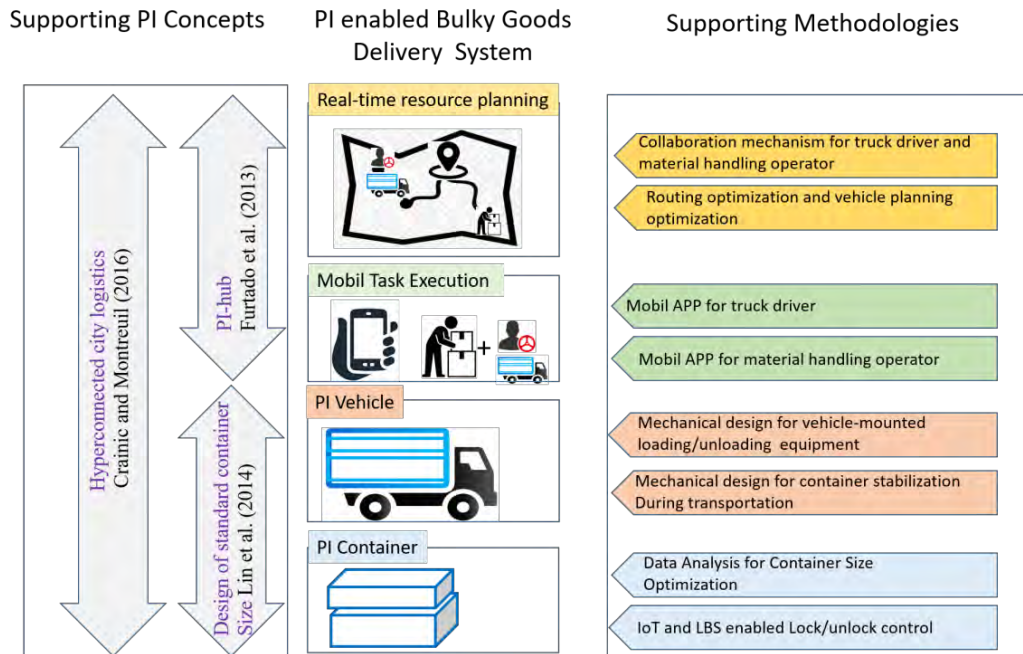

Figure 2: The framework of the design of PI-BGDS

4.1 Design of PI enabled Container

In order to reduce the product damage and to achieve fast loading/unloading, a modularized container is designed based on PI concept. As shown in Figure 3, the design of PI enabled container has following considerations.

4.1.1 The optimized container size

Based on the PI concept, each container can be packing one customer order. Due to the characteristics of customized furniture industry, the product is a board-shape component. The length and width of the component have limited standards. The high dimensions depend on the quantity of component in each order. Therefore, the proposed PI container will have standardized width, length and different height. A data analysis for history order information will be conducted to determine 3-5 container types. A modular container selection model and a decomposition-based solution methodology (Lin et al. 2014) will be applied to optimize the container size design.

4.1.2 On-site movement mechanical design

During the goods delivery, the proposed PI container will be unloaded on the customer indicated destination. In some case, there is a distance between the landing point and freight elevator. The universal wheel set is designed under the container, which can enable the flexible movement on the operation site.

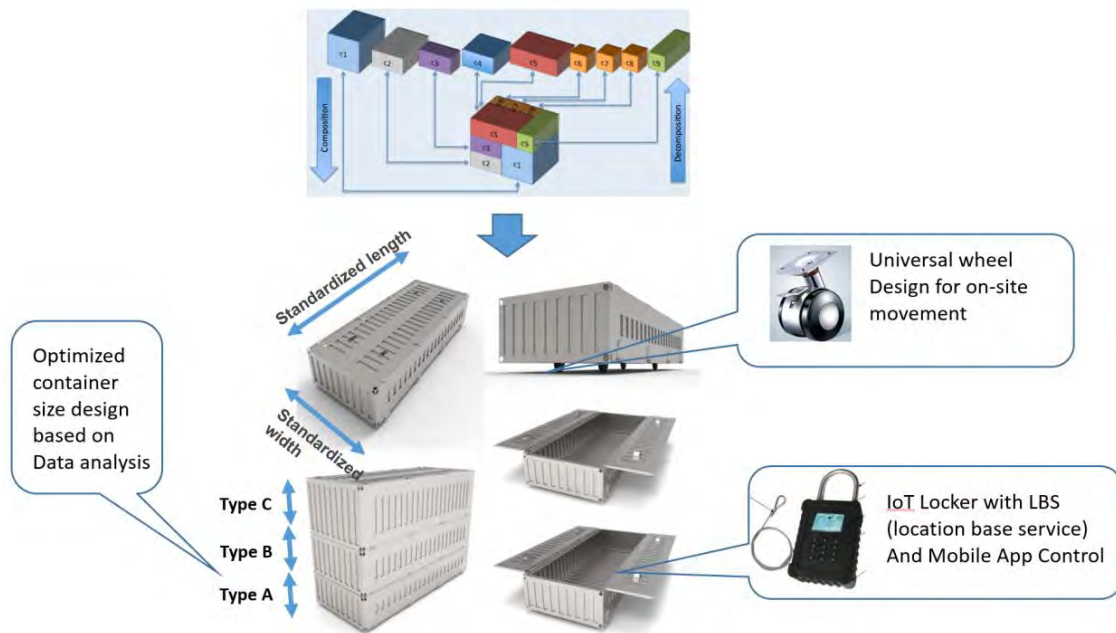

Figure 3: the design of PI enabled container

4.1.3 IoT-enabled Container Locker

In the proposed delivery solution, the material handling work will be conducted by different operators. The container may stay in a public space and waiting for the material handling operator. Therefore, a smart locker is required to guarantee product safe and control the open authorization. The proposed smart locker is equipped with wireless communication module (GPRS/4G/NB-IoT) and location based service module (GPS). The container can only be opened by authorized operator in authorized location.

4.2 Design of PI enabled Vehicle

In order to improve the transportation efficiency, the PI containers on one truck will be dropped on each customers' destination, one by one in a round trip. Meanwhile, the empty container will be collected. Therefore, the aim of the PI enabled vehicle design is to achieve autonomic container loading/unloading on the customer destination without forklift. Figure 4 shows the concept design of proposed PI vehicle. The vehicle-mounted loading/unloading mechanism consists of a shiftable frame, two supporting wheels with electric motor and hydromantic system.

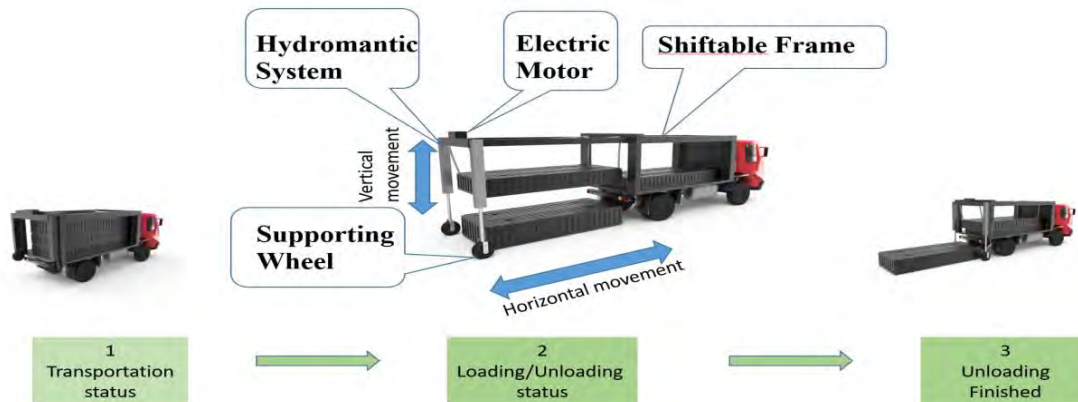

Figure 4: the design of PI enabled Vehicle

The proposed PI vehicle has two working statuses: Transportation status and Loading/Unloading Status. The PI container can be hanged on the shiftable frame. The shiftable frame and two supporting wheels are kept on the retract position in the transportation status. When the vehicle reaches the delivery site, two supporting wheels can extend and stand on the ground. The container on the top will be horizontally moved with the frame to the backend space, and then the container will be vertically put down on the ground by the elevator equipment. The movement of the sliding frame is driven by hydraulic device and the elevator equipment is driven by an electric motor.

4.3 Mobil Task Execution System

In the proposed PI-BGDS, the responsibility for transportation and material handling clearly defined. The truck driver is only responsible for transportation work. When the truck arrives a delivery point, the truck driver can use the vehicle-mounted loading/unloading system to drop down the container and continue the transportation to the next point. The material handling operator will do the in-door movement work individually. Therefore, a mobile task execution system is required for supporting truck driver and material handling operator respectively. The Mobile App for truck driver has 4 major functions: (1) Receiving Delivery Task, (2) Navigation, (3) Report Current Location and (4) Report Task status. The mobile App for material handling operator also has 4 major functions: (1) Receiving Material Handling Task, (2) PI container lock/unlock, (3) Report Current Location and (4) Report Task status.

4.4 Real time resource planning system

Due to the complexity of the delivery network and multiple participators, the operation of PI-BGDS must rely on a high efficient and real-time resource planning system. The resources here indicate human resource (truck driver, material handling operator) and facility resources (PI vehicle and PI container). The real-time resource planning system needs to make 3 types of decisions. (1) Order assignment decision: delivery orders need to be grouped and assigned in one truck shipment. The delivery time, order size and container space should be considered. The objective of this decision is to maximize the vehicle utilization. (2) Routing design decision: the delivery sequence and delivery routing should be designed. The objective of this decision is to be minimized the transportation distance. (3) Operator collaboration decision: the transportation task and the material handling task need to be assigned to specific operators. The objective of this decision is to minimize the total labor cost.

5 Case study

In order to illustrate the application of the proposed system, a case study of bulky goods urban delivery in customized furniture industry is conducted. The case company is founded in 1996, which is one of the leading customized furniture industries in China. Its main business is to provide customers with personalized furniture design, production and installation integrated services.

This company has established innovative business model for customized furniture design, development and manufacturing. Step 1, customer can place an order on their online platform to indicate their basic information: Size of room, function requirement, preferred style and budget. Step 2, a quantity surveyor will go to customer's house and conduct onsite measurement of each room. The measurement service is free. Step 3, the designer will create the 3D design sketch. The customer will go to the design studio to review the sketch with the designer. The design service is also free. Step 4, there is an exhibition hall in each design studio. The customer can review the 3D design sketch and at the same time they can physically touch the different furniture material and experience real life sample room. At this moment, the customer can make the decision whether to place the purchase order. Finally, once the customer takes the payment decision, the design document will be sent to the smart manufacturing center. The whole manufacturing process will be conducted automatically.

Although this company has established advanced Online-offline design and manufacturing system, the finished product logistics is still a big problem.

The case study in this section consists of two parts. The first one is operational feasibility to show the efficiency of propose PI-BGDS. The second one is the economic feasibility to analyze the return on investment (ROI) of PI-BGDS implementation.

5.1 Operational Feasibility Illustration

Figure 5 shows the comparison of traditional delivery process and improved delivery process based on PI-BGDS. In this case, there are 6 delivery points (Customer A, B, C, D, E and F) and 1 product warehouse in the factory. In the delivery process, one truck can load at most 3 customer orders and delivery the orders one by one in a milk run route. The transportation time between each delivery point is about 1 hours. When the PI-Vehicle arrive each delivery point, the unloading time and material moving time from PI-Vehicle to customer's house is about 3 hours.

The upper part of Figure 5 shows the traditional delivery process. In first round delivery, the normal truck loads the products of customer A, B and C at the factory. One material handing operator goes together with the truck driver. When they arrive the delivery point A, the material handing operator conducts the unloading and movement work. The truck has to wait at the delivery point, until all the material handling operation is finished. They go to the next delivery point together. When all of the delivery tasks are finished, the empty truck goes back to factory directly. Then, they can start the next delivery trip of customer D, E and F.

The lower part of Figure 5 shows the improved delivery process based on PI-BGDS. The customer orders are reloaded in the PI container. In the first round, the truck loads the PI container A, B and C at the factory. When truck arrive each delivery point, the PI container can be landed by the vehicle-mounted unloading system and go the next delivery point immediately. When all PI-container A, B and C are delivered. The PI-Vehicle driver continues to delivery point F, E and D to collect 3 empty PI containers back.

The material handling operators conduct their work independently with the truck driver. They can get the material handing task from their mobile APP and go to the working site with a very flexible way. They also can use their mobile APP to find the PI container with GPS location and unlock the PI container with Bluetooth authentication.

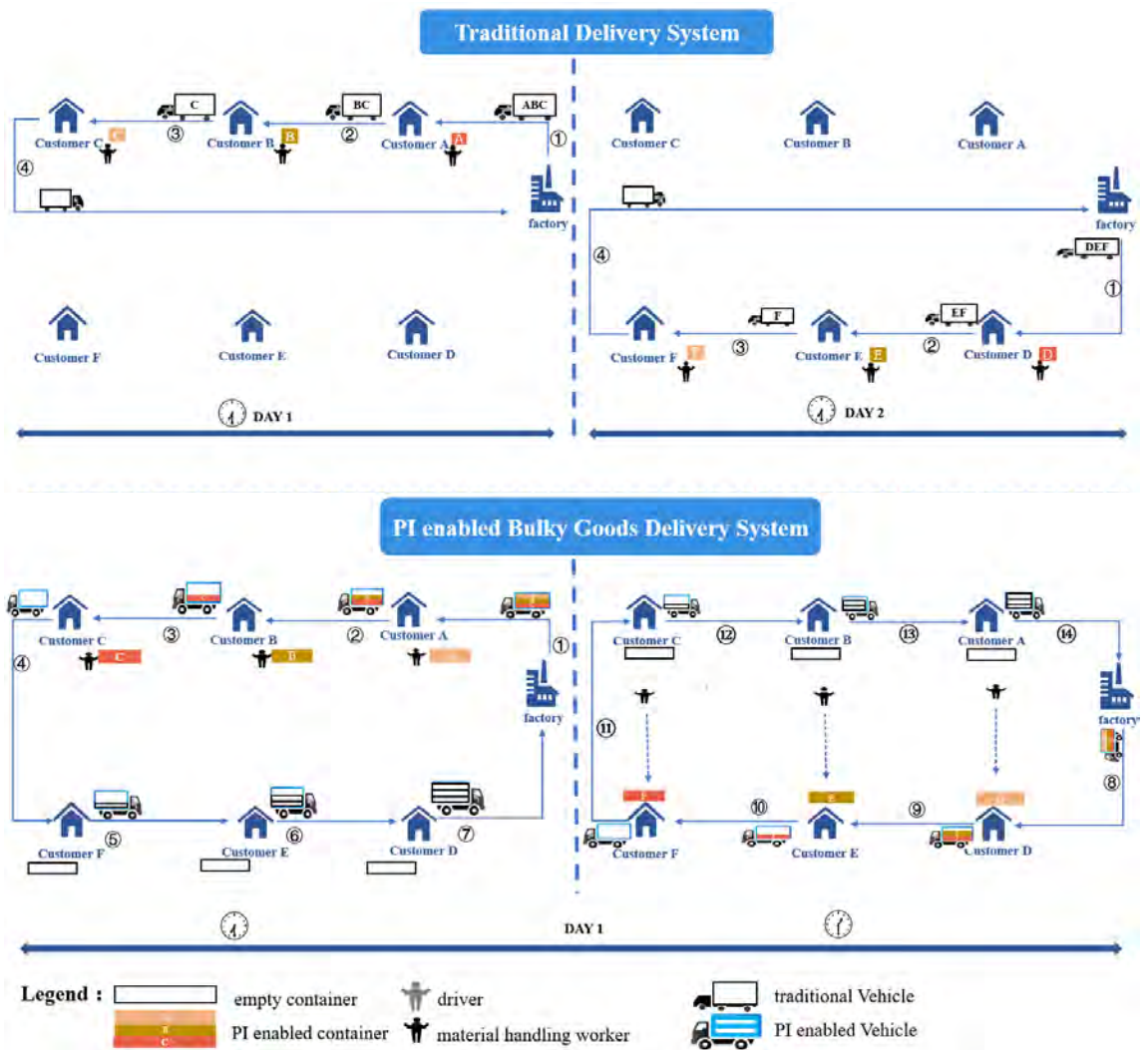

Figure 5: Illustrating comparison urban distribution between Traditional Delivery System and PI-BGDS

Figure 6 shows the comparison of efficiency for two delivery processes. It is easy to find that in the traditional process, the truck driver has very long idle time on each delivery point. Since there are multiple items in each order and the operator has to unloading the item one by one, the unloading time is much longer than the transportation time. The utilization of transportation resources is quite low. Meanwhile, in back trip of each delivery, the truck is empty. The utilization of truck space is also very low. In the improved process, the unloading time of each order is negligible, since the all products in a PI container can be unloaded within one minute. Furthermore, when truck go back to the factory, the driver can go a round trip to collect empty PI containers. In this case, although two more material handling operators are required, the efficiency of transportation is double.

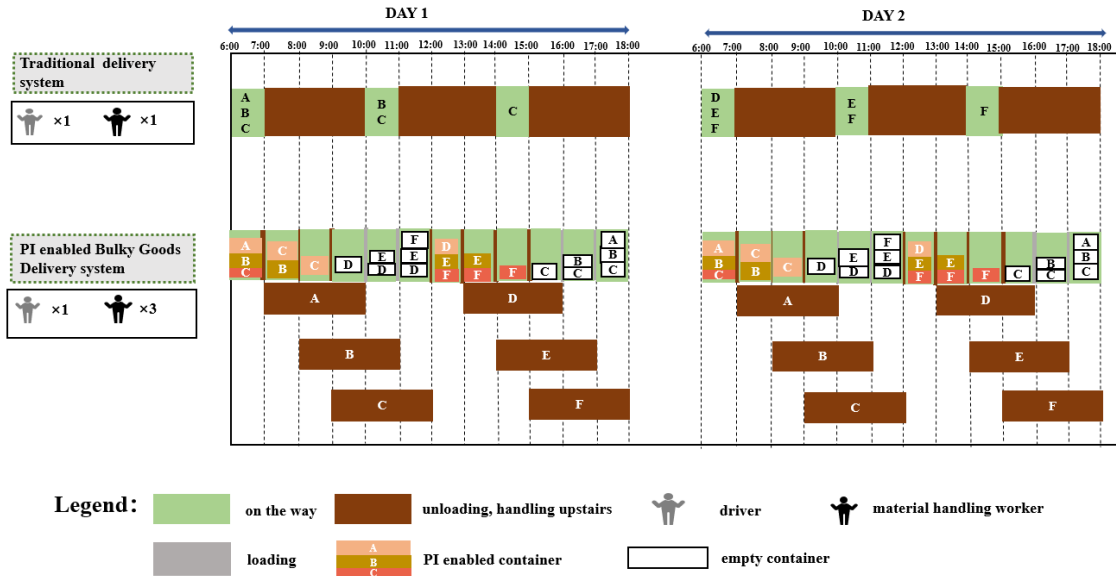

Figure 6: Illustrating comparison of time scheduling between Traditional delivery system and PI-BGDS

5.2 Economic Feasibility Illustration

To further illustrate the economic feasibility of proposed PI-BGDS, the analysis of return on investment of this demo case is conducted. Suppose the logistics company in this case has 10 PI-Vehicles and 50 PI-Containers which are required in their daily operation. The cost of PI container and vehicle-mounted loading/unloading equipment are list in Table 1. The total cost of facility and equipment is RMB 1,250,000.

Table 1: The hardware cost of equipment

Equipment	Quantity	Unit Price(RMB)	Total cost(RMB)
PI enabled Vehicle	10	100,000	1,000,000
PI enabled Container	50	5,000	250,000
Total			1,250,000

Table 2 shows the before-after comparison of operation cost and profit. The transportation fee is 300 RMB/point. The cost of delivery consists of driver salary, material handling operator salary and fuel cost. In the traditional process, 1 truck driver and 1 material handling operator can delivery at most 3 points per day. The fuel cost contains 4 sections (factory-A-B-C-factory). In the proposed PI-BGDS Process, 1 truck driver works with 3 material handling operators can delivery 6 points per day. The fuel cost contains 7 sections (factory-A-B-C-F-E-D-factory). Therefore, the daily profit is increased from 320 RMB to 760 RMB. Considering the investment for 10 PI trucks and 50 PI containers, the period of cost recovery is 284 working day. The return on investment is 84.48%.

Table 2: The Daily Profit statement before and after the design (RMB)

Items	Unit Price (RMB)	Traditional Process (3 delivery point/day)		PI-BGDS Process (6 delivery point/day)	
		Quantity	Total (RMB)	Quantity	Total (RMB)
Income					
Transportation Fee	300/Point	3	900	6	1800
Cost					
Salary of Driver	300/day	1	300	1	300
Salary of Material handling worker	200/day	1	200	3	600
Fuel Cost	20/point	4	80	7	140
Profit			320/day	760/day	
Period of Cost Recovery (10 PI-Vehicles, 30 PI-container)					284 working days
Return on investment (ROI) (240 working day/year)					84.48%

6 Conclusions and outlook

In this study, the bulky goods delivery problem in a customized furniture industry has been addressed. The problems are characterized in 4 aspects, heavy workload of material handling, unclear responsibility for operators, high risk of product damage and complicated human and vehicle resource planning. In order to solve the problem a PI enabled Bulky Goods Delivery System is proposed. The propose system is driven by some key PI concepts, which includes hyperconnected city logistics, PI-hub and design of standard container size.

This study has made several contributions: (1) the key challenges and pain points of bulky goods delivery, especially in customized furniture industry are identified. (2) This is a preliminary attempt to apply the PI concept into bulky goods urban delivery and a PI enabled Bulky Goods Delivery System is proposed. (3) The case study in the customized furniture company indicates that the proposed solution can improve the efficiency of transportation. It also has good ROI for logistics service providers.

However, this study only addressed the structure of PI-BGDS. Several research problems need further investigation. For example, the IT structure of Mobil Apps and optimization algorithm for resource planning. Future studies will focus on making the proposed solutions more practical. How to generalize the results of such a small sample to a broader context will become the next step for our research and development.

Acknowledgement

This work was supported in part by Zhejiang Provincial, Hangzhou Municipal, Lin'an City governments, ITF Innovation and Technology Support Programme of Hong Kong Government (ITP/079/16LP), HKSAR RGC GRF (No. 17212016; No. 17203117) and National Natural Science Foundation of China (No. 71671116; No. 71701079).

References

- Ballot, E., Montreuil, B., Thivierge, C. (2012): Functional design of physical internet facilities: A road-rail hub.
- Ballot, E., Montreuil, B. (2016): Transport Items and Physical Internet Handling Boxes: a Comparison Framework Across Supply Chains.
- Coelho, L. C., Gagliardi, J. P., Renaud, J., Ruiz, A. (2016): Solving the vehicle routing problem with lunch break arising in the furniture delivery industry. *Journal of the Operational Research Society*, 67(5), 743-751.
- Crainic, T. G., Montreuil, B. (2016): Physical Internet Enabled Hyperconnected City Logistics. *Transportation Research Procedia*, 12, 383-398.
- Faure, L., Montreuil, B., Burlat, P., Marquès, G. (2014): Ex ante sustainability improvement assessment of city logistics solutions: learning from a simple interlinked pooling case. In *Proceedings of 1st International Physical Internet Conference*, Québec, Canada.
- Furtado, P., Frayret, J. M., Fakhfakh, R., Biard, P. (2013): Simulation of a Physical Internet—Based transportation network. In *Industrial Engineering and Systems Management (IESM), Proceedings of 2013 International Conference on IEEE*.
- Gubbi, J., Buyya, R., Marusic, S., Palaniswami, M. (2013): Internet of Things (IoT): A vision, architectural elements, and future directions. *Future Generation Computer Systems*, v2, no7, 1645-1660.
- Hakimi, D., Montreuil, B., Sarraj, R., Ballot, E., Pan, S. (2012): Simulating a physical internet enabled mobility web: the case of mass distribution in France.
- Hemmelmayer, V. C., Jean-François, C., Gabriel, C. T. (2012): An adaptive large neighborhood search heuristic for Two-Echelon Vehicle Routing Problems arising in city logistics. *Computers Operations Research*, v39, no12, 3215-3228.
- Kotha, S. (1996): From mass production to mass customization: The case of the National Industrial Bicycle Company of Japan. *European Management Journal*, v14, no5, 442-450.
- Lin, Y.-H., R. D. Meller, K. P. Ellis, L. M. Thomas, and B. J. Lombardi. (2014): A decomposition-based approach for the selection of standardized modular containers. In *International Journal of Production Research*, v52, no15, 4660–4672.
- Lin, I. C., Cheng, C. Y. (2016): Case study of physical internet for improving efficiency in solar cell industry. *Journal of Ambient Intelligence Humanized Computing*(1), 1-10.
- Luo, H., Chen, J., Huang, G. Q. (2016): IoT enabled production-logistic Synchronization: A case study in make-to-order industry, In: *2nd International Physical Internet Conference*, Paris.
- Ma, M. P. B. (2017): Putting the Physical Internet into practice - Current developments and application examples.
- Meller, R. D., B. Montreuil, C. Thivierge, and Z. Montreuil. (2014): Functional Design of Physical Internet Facilities: A Road-Based Transit Center, In *Progress in Material Handling Research*. v12, edited by B. Montreuil, A. Carrano, K. Gue, R. de Koster, M. Ogle, and J. Smith, 347–378. USA: MHI, Charlotte, NC.
- Mohamed, I. B., Klibi, W., Labarthe, O., Deschamps, J. C., Babai, M. Z. (2017): Modelling and solution approaches for the interconnected city logistics. *International Journal of Production Research*, v55, no9, 2664-2684.
- Montreuil, B., Russell, M. (2010): Towards a Physical Internet: the impact on logistics facilities and material handling systems design and innovation. *Progress in material handling research*, 305-327.
- Montreuil, B., Meller, R. D., Ballot, E. (2010): Towards a Physical Internet: the impact on logistics facilities and material handling systems design and innovation. *Progress in material handling research*, 305-327.

-
- Montreuil, B. (2011): Toward a Physical Internet: meeting the global logistics sustainability grand challenge. *Logistics Research*, v3, no2-3, 71-87.
- Montreuil, B., R. D. Meller, C. Thivierge, and Z. Montreuil. (2014): Functional design of physical Internet facilities: A unimodal road-based crossdocking hub. CIRRELT, Centre interuniversitaire de recherche sur les réseaux d'entreprise, la logistique et le transport= Interuniversity Research Centre on Enterprise Networks, Logistics and Transportation.
- Pan, S., Chen, C., Zhong, R. Y. (2015a): A crowdsourcing solution to collect e-commerce reverse flows in metropolitan areas. *IFAC-PapersOnLine*, v48, no3, 1984-1989.
- Pan, S., Nigrelli, M., Ballot, E., Sarraj, R., Yang, Y. (2015b): Perspectives of inventory control models in the Physical Internet: A simulation study. *Computers & Industrial Engineering*, 84, 122-132.
- Pan, S., Ballot, E., Huang, G. Q., Montreuil, B. (2017): Physical Internet and interconnected logistics services: research and applications. *International Journal of Production Research*, v5, no9, 2603-2609.
- Rougès, J. F., Montreuil, B. Crowdsourcing delivery (2014): New interconnected business models to reinvent delivery. In: 1st international physical internet conference, Québec, Canada.
- Sallez, Y., Pan, S., Montreuil, B., Berger, T., Ballot, E. (2016): On the activeness of intelligent Physical Internet containers. *Computers in Industry*, 81, 96-104.
- Schroth, C., Janner, T. (2007): Web 2.0 and SOA: Converging concepts enabling the internet of services. *IT professional*, v9, no3, <https://www.alexandria.unisg.ch/37270/1/036-041.pdf>
- Treiblmaier, H., Mirkovski, K., Lowry, P. B. (2016): Conceptualizing the Physical Internet: Literature Review, Implications and Directions for Future Research. Social Science Electronic Publishing.
- Urbahn, D., Krämer, T. (1993): Protective bag-like sleeve for furniture or other bulky goods during transport.
- Xu, J. A., Lu, H. A., Gong, Y. (2013): A Brief Analysis of How to Shorten the Custom Furniture Delivery Date. *Furniture & Interior Design*, 1, 029.
- Xu, Xiaozhou, Pan, Shenle, Ballot, Eric (2013): A Sharing Mechanism for Superadditive and Non-Superadditive Logistics Cooperation. In: International Conference on Industrial Engineering and Systems Management. Rabat, Morocco, October 28-30, 1–10.
- Zhang, Y., Liu, S., Liu, Y., Li, R. (2016): Smart box-enabled product-service system for cloud logistics. *International Journal of Production Research*, v54, no22, 6693-6706.
- Zhong, R. Y., Xu, C., Chen, C., Huang, G. Q. (2017): Big Data Analytics for Physical Internet-based intelligent manufacturing shop floors. *International Journal of Production Research*, v55, no9, 2610-2621.

Analogies across Hubs and Routers in the Physical and Digital Internet

Jordi Arjona Aroca¹ and Salvador Furió Pruñonosa¹

1. Fundación Valenciaport, Valencia, Spain

Corresponding author: {jarjona, sfurio}@fundacion.valenciaport.com

Abstract: *The Physical Internet initiative has promised to revolutionize logistics by applying lessons and importing know-how from the world of communications, the digital internet. Expectations are to reduce the deadheads, to increase the average occupation of transports, or to reduce fuel consumption and emissions, among others. In general, a substantial increase of efficiency in nowadays logistics. Routers play a key role in the digital internet, receiving packets, processing them, performing routing actions deciding what is their best next hop, and forwarding the packet towards it. However, we still see their Physical Internet equivalents, logistics hubs, as black boxes.*

In this work we study the analogies between routers and hubs, between the types of routers and their hierarchical structure in the digital internet and types of hubs, and how logistics are structured nowadays. Based on this study we propose a model of operations general for any hub, proving its correctness by showing how it adjusts to different types of hub. This model will act as an enabler to define key operational parameters in hubs mathematically and in a general way. This will ease the construction of new routing algorithms horizontal for the different types of hyperconnected hubs in the Physical Internet.

Keywords: *hubs, routing, forwarding, routers, physical internet*

1 Introduction

Logistics is one of the pillars of nowadays economy. Imports and exports accounted for more than \$16 trillion per year (UNCTAD, 2017a) between 2015 and 2017, roughly 60% of world's GDP (McKinsey, 2017). In 2017, maritime transportation contributed with approximately 10:6 million tones transported (UNCTAD, 2017b) distributed in 205 million loaded containers (Drewry, 2017)¹. However, despite its importance, logistics are highly inefficient. The traffic of empty containers reached the 67 million units, barely a 25% of the total traffic. Moreover, in road transportations, approximately 23% of miles were traveled empty and, on laden trips, containers average occupation is around 30-40% (European Commission & Transport, 2017).

This inefficiency is mostly a consequence of the rigidity of logistics standards or lack of data sharing among operators. For instance, current container standard size is 20 feet long. Many times, if a logistic operator is not moving enough goods to fill it, it will not share it with another operator on the same route (luckily, cargo consolidators are helping to reduce this practice). Similarly, trucks may go unloaded to a port or another logistic hub to transport arriving containers, while others may go loaded to leave departing containers and return unloaded. This results in a wastage of resources, fuel or space, among others.

The Physical Internet (PI) initiative (Montreuil, 2011) aims to change the way we conceive logistics nowadays. From agent-centric and highly inefficient private transportation networks, we will move to package-centric, open logistic networks with increased efficiency thanks to

¹ Table 2.1 in (Drewry, 2017), loaded container traffic calculated as half the port-to-port full containers.

data sharing among operators and reduced costs thanks to modular standardized containers (Modulushca), leading to little space and time wastage, and becoming environmentally friendlier. PI is inspired by the digital internet (DI). Some aspects to acquire from DI would be its distributed and shared nature, where all data shares end-to-end communication channels; or where each network node can decide in real time the best next hop for a package, avoiding preset routes that may become inefficient due to unexpected delays.

For this reason, the community has started to build architectures for the PI (Colinet et al., 2016; Pal & Kant, 2016) based on analogies with the DI. However, although some works focus on hubs (Sarraj et al., 2014), these are usually seen as black boxes that receive, store and deliver goods. Nevertheless, characterizing logistic hubs will allow us to define the new algorithms, roles, or agents of tomorrow, shaping the new shipping reality.

We focus on the search of analogies between logistic hubs and routers in the digital internet. Routers have a central role in the DI, in charge of receiving and processing packets, and deciding what is their next hop in the network. Routers perform different key operations, like forwarding, (de)encapsulation, mode transfer or routing. Moreover, depending on the type of router and the traffic it handles, additional operations and policy checks may take place. Similarly to routers in the internet, logistic hubs are the key facilitators of goods movement forwarding, classifying, routing, (de)consolidation and other central operations in current logistics.

In spite of similitudes, there are also capital differences. For instance, latency in routers is negligible, but turnover time in hubs is not. Similarly, package destinations are unknown to routers until it is de-encapsulated, a hub can learn the destination of incoming goods in advance, allowing to plan its routing ahead in time. In this work we perform an analysis on the features and operations of routers, looking for similarities and differences with hubs in the logistics world, in order to understand what can be imported to the PI, what cannot be replicated and what may be improved.

Hence, the contributions of this paper are fourfold. First, we perform an analysis exposing physical and operational similarities and differences between routers and hubs. Second, we propose a hierarchical taxonomy for logistics hubs that can be mapped to the digital internet router hierarchy. Third, we propose a model of the operations affecting the turnover of goods on their stopover in a hub. Finally, we validate this model showing how different types of hub adjust to it.

The rest of the paper is organized as follows. Section 2 introduces related work in the field. In Section 3 we perform an analysis of digital routers, their features, their types, and main operations, proposing a simplified model of them. Section 4 continues with a similar analysis on logistics hubs, stating their features, propose the use of a concrete taxonomy, and build again a simplified and general model of hub operations. Section 5 validates the proposed model showing how it adjusts to different types of hubs. Section 6 discusses a series of key differentiators, positive and negative, between the physical and digital internet as well as shows, in a context, the importance of the proposed model. Finally, Section 7 presents our conclusions.

2 Related work

There is a vast amount of literature hubs and transport models. In this review we focus on those works relating logistics hubs and the Physical Internet, One topic of interest has been hub design and the exchange of cargo in different types of hubs. Meller et al. (2012) proposed a model for road-based centers, designing unimodal road based transit sites. Similarly, Chargui et al. (2016) and Hao et al. (2016) proposed different designs and strategies for moving goods in cross-dock and rail-to-rail hubs, respectively. These works focus in particular types of unimodal hubs, and

how the cargo is to be moved within. We go one step above and propose a general model of the operations for every hub, regardless of the number of modes, so it serves as a basis to define common routing strategies and algorithms for heterogeneous logistic networks. In fact, the model used in Meller et al. (2012) can be seen as a particular case of ours. Oppositely to us, Romstorfer et al. (2017) described in detail an end-to-end transport chain for air cargos. This work depicts the extreme complexity of the entire chain, which englobes a large number of actors and processes. Our work intends to simplify this complexity.

Another relevant topic is hyperconnected logistics and hubs. In this regard, Kim et al. (2017) assessed the advantages of hyperconnected hubs in terms of capacity and service capabilities compared to traditional hubs. Similarly, Buckley et al. (2017) studied the advantages of different configurations of hyperconnected crossdocking hubs in urban localities. Both papers work on the advantages and interaction of hyperconnected hubs but do not deepen into the operations within. The analysis and model proposed in this work should work as enablers for hyperconnected logistics. Finally, Sarraj et al. (2014) worked on the analogies between DI and PI hubs. Although with a shared focus, we differ in aspects like the definition of autonomous systems and in the mapping of the DI and PI architectures. Similarly, we try to go step beyond providing a model of the end-to-end lifecycle of a package within a hub.

3 Routers, interconnecting the DI

The three most common interconnection devices in the digital world are hubs, switches and routers. Of these three devices, only routers reach the Internet layer, i.e., layer two, in the TCP/IP model, being able to route across nodes (e.g., laptops, cellphones or desktops) in different domains. We now provide a brief description of their physical characteristics, types and functionalities.

3.1 Main features of a router

A router sends and receives data packets through interfaces called ports. The number of ports in a router is variable. Similarly, these ports can belong to different modes, usually copper (e.g., Ethernet, Fast Ethernet, or 1 Gigabyte) or optical fiber (e.g., 10G, 40G). Although not a port per se, there can also be wireless mode. Ports are duplex and have a maximum bandwidth, which is the amount of incoming/outgoing data a port can process per second. Each port has input and output buffers where data is temporarily stored before being processed or delivered.

Once the data is in the router, it de-encapsulates the data in the packets up to TCP/IP layer two (equivalent to the OSI model layer three). These packets have a maximum size per layer, denoted as Maximum Transfer Unit (MTU). Then, the router executes a routing algorithm to decide the outgoing port, encapsulates into packets again, and forwards them. The forwarding also depends of the interconnection matrix, which provides the interconnection between the different ports. This matrix has also a maximum bandwidth that can be lower than the aggregated bandwidth of the different ports. Once the packet reaches the outgoing port it is stored in its output buffer. The different components of the router can be seen in Figure 1.

3.2 Internet structure and types of router

The internet is structured as a hierarchical tree where the different nodes are called Autonomous Systems (AS). The ASs in the highest tiers of the tree provide worldwide connectivity, interconnecting the ASs in lower tier. These ASs do provide connectivity to end users. The ASs

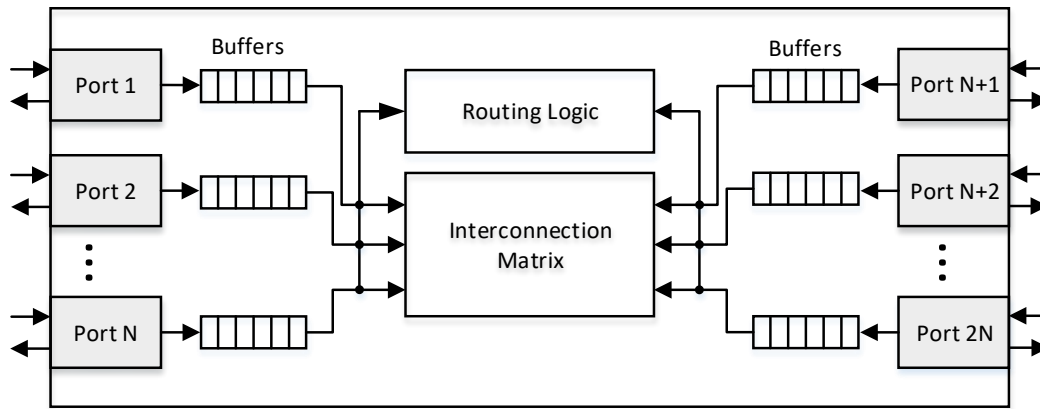

Figure 1: Scheme of a router with $2N$ ports. Ports can belong to different physical modes like fiber, copper or even wireless. Once the packet arrives, it is stored temporarily in the buffers before being de-encapsulated and processed by the routing logic that will decide the next hop. Then, the router will forward it adequately through the right output port.

in the Lower tier are usually owned by Internet Service Providers (ISPs) or even by large companies. In general, only the ASs in the lowest tier provide end user connectivity, being the ASs in the highest and intermediate tiers *transit* ASs, i.e., ASs that are not the final destination of the traffic and only route it to other ASs.

An AS is a connected group of one or more IP prefixes run by one or more network operators which has a single and clearly defined routing policy (Hawkinson & Bates, 1996). An AS can be usually mapped to a country, as ISPs, even if multinational, normally divide their users per country. However, this is merely coincidental and there are ASs which can span multiple countries. Bottom-up, the structure of an AS starts with a number of internal networks serving different clients or end users. These networks are grouped in areas. Depending on the complexity of the AS there may be an intermediate tier denoted subarea. In addition to internal client networks, ASs include a backbone network that grants the connectivity across the different tiers within the AS as well as to other ASs. Routers are classified according to their function in this hierarchy. A general classification of types of routers is the following:

- AS Border Routers (ASBRs): ASBRs are a type of backbone nodes that provide inter-AS connectivity, routing the traffic across different the ASs.
- Area Border Routers (ABRs): these are also backbone nodes. However, their scope is limited to the AS and act as the gateway of a particular Area. ABRs route traffic from/to other backbone routers within the same AS but outside its Area.
- Core Routers (CRs): increase the density of the backbone network, providing backbone connectivity to ABRs and ASBRs.
- Internal routers: placed within areas and sub-areas, provide connectivity to the end user networks.

Figure 2 shows an example of the internal structure of an AS and how the different types of routers within may interconnect.

3.3 Operations in routers

The main operations in a router are forwarding, routing and (de)encapsulation. These operations occur in an embedded and sequential way. To describe them, we follow the lifecycle of a packet in a router, represented in Figure 3 for non-ASBRs and ASBRs.

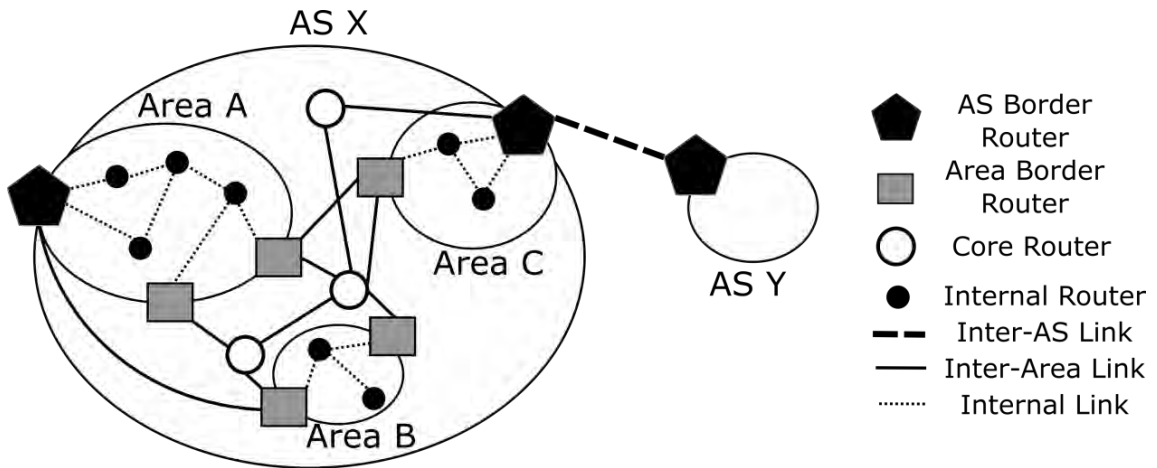

Figure 2: Interconnection scheme within an Autonomous System in the lowest tier. AS border routers act as AS gateways. Area border routers, likewise, are the gateways of Areas. Core routers increase the AS internal connectivity. Finally, internal routers provide connectivity to end users.

Forwarding relates to the physical operations that affect the packet. It includes the initial stages a packet goes through after its reception: reception through a port, layer one integrity operations, buffering, and delivery to the routing logic. Along these operations, de-encapsulation takes place. De-encapsulation consists of the successive removal of packet headers as it moves up through the TCP/IP model. Routers remove layer one headers so the routing logic consumes the layer two packet.

Oppositely to forwarding, routing is a control plane operation. The routing logic uses the packet destination to decide its best next hop. Within an AS, this decision is based on metrics such as latency and number of hops, and protocols like OSPF or IS-IS. In ASBRs, though, routing is performed using the BGP protocol. In this case, next hop selection depends on a set of economic policies and agreements between ASs and not only by instant metrics like latency.

The selection of the next hop implies the use of an outgoing port. The relation between next hops and outgoing ports is stored in routing tables. After selecting the outgoing port the packet is successively encapsulated, forwarded to the outgoing port, buffered, has its integrity checked, and delivered.

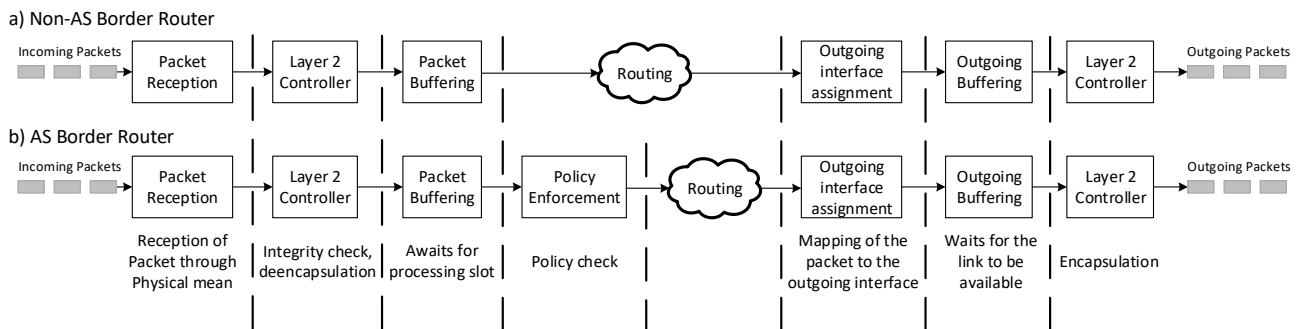

Figure 3: Stages in a) non-ASB router and b) an ASB router. Note that in ASB routers the policy check is based on monetary metrics and agreements, so the decided routing is conditioned may be not optimal from the latency or number of hops point of view.

4 Hubs in the PI

Differently to the DI, there is a wide variety of hub types in the physical world. There are several criteria to classify them like whether they are public or private, for transport or distribution, spatial capacity, but most classifications focus on the features and activities performed in these hubs (Huber et al., 2015).

In this section, we first identify some of the physical features that are similar in routers and physical hubs. Then, we propose a hub taxonomy based on multiple dimensions like its area of influence or range of offered services. Afterwards, we provide our own definition of AS for the PI. Then, based on the proposed definition of AS and the hub taxonomy, we show that logistics follow a hierarchical structure similar analogous to the one of the DI. Additionally, we map the types of hubs in the logistics hierarchy to those in the DI structure. Finally, we repeat the exercise of describing the lifecycle of a package in a logistics hub to observe the parallelisms to that of a data packet in the DI. Based on this, we propose a model of the operations performed by hubs on arriving goods.

4.1 Main features of a logistic hub

We first describe a minimal set of features of a logistic hub. This minimal set is common to every type of hub. The features included are:

- Transport modes: types of transport allowed in a hub, e.g., air, maritime, railways or roads. It is equivalent to the modes in the DI.
- Inbound/outbound docks: determine the number of vehicles of different modes a hub can host simultaneously. Equivalent to ports in the DI.
- Turnover time: measurement of the time it takes for a hub to receive a transport mean, unload its goods and load new ones, perform any operation that affects the transport mean and allow its departure. Turnover time would be the inverse of bandwidth in the DI.
- Storage areas: hubs must allow for packets to be stored for short or long periods of time, depending of whether they are aimed at transport or distribution, respectively. A hub may have multiple storage areas, usually serving one or more docks of the same mode. They are equivalent to buffers in DI routers.
- Package reallocation: mechanical or human forces in charge of moving the package between transport means and storage areas during the transshipment process. Similar to the interconnection matrix in routers.
- (De-)Encapsulation/(de)composition: hubs may de-encapsulate and decompose the load arriving through one mode and reallocate it in different outbound means. Similarly to DI, hubs have a Minimal handling unit (MHU) that determines at which granularity is the port going to manipulate the cargo, e.g., container or intermodal transport units (ITUs), pallet or boxes. Actually, one of PI battle horses, and of projects like Modulushka (Modulushca, n.d.), is defining new standard container sizes to enable a finer grain transportation in logistics.

To the best of our knowledge, all types of hubs share these features. However, different hubs offer them in a lower or higher degree or size, as well as vary in the range of additional services or activities they provide, or the impact the hub has on its geopolitical environment.

4.2 Types of hub

There are multiple hub taxonomies in the literature, most based on a single dimension, e.g., the size, the logistic facilities hierarchy or the functional hierarchy of the hub. Higgins et al. (2012) proposed one of the most complete ones, that takes into account these three dimensions and

defines a three-levels taxonomy according to hubs scope of activities: gateways, freight transportation and distribution clusters, and warehousing and distribution centers. We build a slightly different classification taking into account different parameters. We look at the hub's area of influence, the variety of services it offers, specially customs services, the largest and smallest handling unit it can work with and its intermodality capabilities, and its warehousing capability. This leads us, as well, to a three stratum taxonomy:

- Gateways: include mainport terminals like seaports or airports. These hubs have the largest area of influence, being the gate to move goods at international level. Gateways are able to handle ITUs and other large handling units, like coils or cars. Decomposition of cargo is infrequent. Among the widest variety of logistic services, including customs services. Offers long and short-term storage services, mainly the latter. Gateways typically act as an interface between regional and global trade.
- Large regional distribution hubs: include freight villages, inland ports, intermodal terminals, among others. Its area of influence is national or within a customs domain (e.g., single markets, economic unions). These hubs receive, redirect and distribute large flows of cargo across regions as well as facilitators of distribution within their region. Large regional distribution hubs usually offer transport mode transfer and deal with a wide range of handling unit sizes, from containers, swapbodies or semitrailers to pallets or boxes. Similarly, it offers decomposition of handling units into smaller ones. Service wise, they offer a wide variety of logistic services but they do not provide customs services. Exceptionally, though, one of these types of hub may act as a satellite terminal of mainport terminals and include some value added services like customs clearance, but always under the control of the gateway hub. Finally, provide long and short storage capacity.
- Classification centers: include local consolidation, distribution or classification centers, among others. The hubs in this third stratum are usually the smaller ones in terms of size and in range of offered services. At the same time, these are the closest ones to the final user, typically providing last mile services. Commonly, these hubs do not handle ITUs, but smaller handling units like pallets or boxes. They perform consolidation, decomposition and classification of goods and are mainly dedicated to agile distribution rather than storage of goods. Classification centers are relevant at regional and urban level. The range of services offered rarely span more than rapid distribution of goods across local hubs or to local users.

4.3 Autonomous systems in the PI

We defined the ASs in the DI as a connected group of prefixes with a common operator and a shared well-defined routing policy. Hubs and end users are the prefixes in the PI. Sarraj et al. (2014) map ASs to logistic networks managed by a single company or organization. From our point of view, the advent of the PI will bring changes in nowadays business models and lead to a transformation of most of current logistic networks from a proprietary profile to a collaborative one. This does not mean that proprietary logistics networks cease to exist, but that they will exist as part of the PI and will have the chance to share part of their resources with other agents in order to reduce costs and increase efficiency.

Moreover, we see a clear equivalence between the AS-based DI hierarchical structure and a structure based on the geographical scope of a hub in logistics. Geographically, in logistics, the hierarchical structure would go, bottom-up, from last-mile delivery, cities and small regions, to regional and even national logistics and, finally, to international, continental, single markets (SM), economic unions (EU), respectively. Similarly, we can associate each of the three hub

categories we introduced in 4.2 to each of the levels in this geographical hierarchy according to the hub scope. The resulting structure would be as follows:

- **AS:** rules within an AS must be shared by all operators and well defined. We identify ASs with SMs, EUs or countries for three reasons: no internal trade barriers, a common external tariff, and free factor and asset mobility (Wetherly, 2014). These areas are governed by a clearly defined and common set of rules for all logistics agents operating within. Similarly, any goods coming from outside the AS have to go through a customs clearance, subject to tariffs, economical policies and agreements similar to the ones across DI ASs, as described in Section 3.3. The hubs at this level, equivalent to ASBRs, would be the hubs in the first stratum, i.e., gateways like seaports or airports.
- **Areas and sub-areas:** locality is important in the movement of goods and assets. Therefore, regions with dense trade networks can be modeled as areas or sub-areas, depending on the size of the AS. In logistics, the amount of services offered is also relevant. ABRs and CRs would then correspond to large regional distribution hubs, like freight villages, inland ports or intermodal terminals.
- **Local networks:** map to metropolitan areas and last-mile in the PI. Hubs at this level serve the end users or local logistics agents. Internal routers would, hence, be comparable in functionality to classification centers, including local distribution centers, inland container depots or warehouses and open-air container yards.

4.4 Operations in a PI hub

We now propose a model for the operations taking place in a hub. This model intends to be simple and general at the same time, covering the operation of any type of hub. This model is inspired by the one shown in Section 3.3 and brings together the operations performed by routers on data packets and the minimal set of hub features described at the beginning of this section. Figure 4 presents the proposed model for inter and intra AS goods, describing the lifecycle of a good in a logistics hub.

First step is allowing the transport mean into the unloading dock. This may seem trivial in a classification or road based crossdocking center but it is not in a port or airport. Secondly, goods have to be unloaded. At this point, a manipulation of the goods may take place, composing, decomposing or combining packages according to their destination. Once unloaded, they are moved to a storage area where they will wait to be transported to the loading area of the selected departure transport once the latter is decided. Finally, the initial process is repeated inversely, goods are loaded and the selected transport is helped to leave the dock, if required. Note that these are all physical plane processes, equivalent to the forwarding and (de)encapsulation in the DI. Observe, as well, that there is one physical plane process that is not common to every hub, the customs clearance. Given its legal implications, customs clearance can only be provided by specific hubs, usually main port terminals or satellite hubs associated to them, as described in Section 4.2.

There are other value added services which can be provided by hubs as well, many of them to the transport means (e.g., cleaning, refueling and bunkering, basic supplies). The availability of these services may also determine the election of a hub before another, but should not affect the turnover time, as they should be provided in parallel to the loading/unloading of the transport mean or while it is waiting.

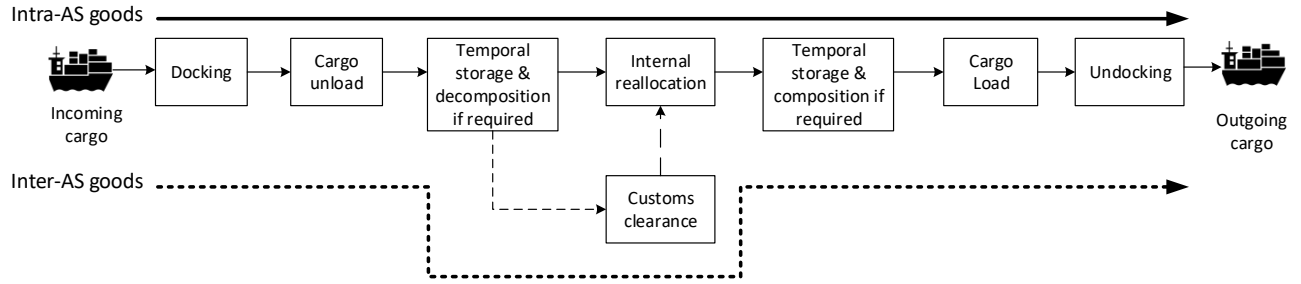

Figure 4: General model for the operations on goods in a physical hub. All the different stages a good arriving at a hub has to go through are captured in it regardless of the type of hub.

Defining such a model is required because the turnover time at hubs is non-negligible and needs to be quantified in order to make optimal routing decisions. In the physical internet, control and physical plane operations can be detached. The control plane data consists in the cargo manifests exchanged between hubs and carriers. Exchanging these data before arrival allows routing decisions to be taken before goods arrive to the port, e.g., selecting the outbound mode, the dock from which it will depart or the expected time of departure. There is a series of parameters that will have to be defined mathematically in order to optimize these decisions. Defining these parameters in a general and common way to every type of hub will allow us to create routing algorithms that are agnostic to the types of hubs in a network. The proposed model offers this common ground.

We now provide some examples of parameters of interest: the time at which a good will be available after being unloaded, T_{av} ; the service window time in a dock for a transport, T_s , and its expected time of departure, ETD ; or the expected time of storage of a good, T_{st} . We define them below:

$$T_{av} = ETA + T_{dk} + \sum_{i=1}^k T_u^i + T_{dc} \quad (1)$$

$$T_s = T_{dk} + \sum_{i=1}^n T_l^i + \sum_{i=1}^m T_u^j + T_{udk} \quad (2)$$

$$ETD = ETA + T_s \quad (3)$$

$$T_{st} = ETD - T_{dk} - \sum_{i=k+1}^n T_u^i - T_c - T_r - T_{ct} \quad (4)$$

where ETA and ETD are the expected times of arrival and departure of a transport. T_{dk} and T_{udk} denote are the time used for docking and undocking the transport mean. T_l and T_u the times for loading and unloading a particular good, being n and m the goods to be loaded or unloaded and k the number of goods (un)loaded before the current one. T_c and T_{dc} denote the time used for composing and decomposing a cargo. With T_r we denote the time to reallocate a good within the hub. Finally, T_{ct} denotes the time in customs inspection, if applies. These parameters, and many other, are computed differently depending on the type of hub, but can be defined in the same way. Note that these parameters are only to exemplify the usability of the model. The stochastic nature of the variables is not observed here and more complex equations should be devised in a real deployment.

5 Practical Cases

We now study different types of hub and how their operations adjust to it. We take one hub from each one of the categories proposed in Section 4.2, namely, a seaport, an Intermodal Distribution Centre (IDC) and a Cross-Docking Classification Centre (CDCC). In Section 4.4

we defined mathematically a series of parameters using variables that were based on the provided model, independently of the hub at which those are measured. We now show that these variables would differ with the type of hub depending on the particular operations taking place in them. Therefore, the generality of the definition of the parameters would not be affected by the particularities of the hubs. The mapping of the model stages to the hub operations is presented in Table 1.

In seaports T_{dk} and T_{udk} depend on the nautical services: pilotage, mooring and tugging operations. For IDCs and CDCCs, these parameters only depend on the time it takes to maneuver the truck into or out of the dock, or to undertake rail shunting operations, if any. In the seaport, T_l and T_u depend on the different terminal cranes, that (un)load containers from ships and allocate or pick them from the yard. If containers were PI-containers, a T_c or T_{dc} would be needed as well, carried out by cranes as well. In IDCs, T_l and T_u usually depend on cranes and reach stackers, as do possible T_c or T_{dc} in case there is a change in the size of the handling unit (e.g., ITUs to pallets). In CDCCs these times depend on forklifts and human labor, while possible (de)compositions would depend on human labor. Finally, T_r would depend on the operation of cranes and other internal transport means in seaports; on cranes, internal transport, forklifts or conveying units in IDCs; and on forklifts, human labor or conveying units in CDCCs.

In all cases the model serves as a general scheme where to frame the different hub operations affecting goods. As shown, relevant parameters for possible routing algorithms can be defined in a general way, but capturing the particularities of the different types of hub.

6 Discussion: from hubs to PI hubs

Physical and digital internet have insurmountable differences that cannot be ignored. In the DI, the time data packets spend in a hub is negligible. Hence, routing depends only on the latency, available bandwidth or similar metrics measured in the links. Upon a delivery error, packets can be replicated at zero cost and simply re-sent or sent through a different port. Upon failing links, a router will just redirect the next packets through another port, possibly towards a different next hop. Moreover, depending on the protocol, a lost packet may even be discarded (e.g., UDP) as this is the best option for certain types of traffic (e.g., video streaming). Routing is not always a per-packet decision. For virtual circuit based connections (e.g., MPLS), routing is decided for the first packet, the rest follow the same path.

However, DI has its drawbacks as well. Routing cannot be planned in advance as the router learns about packet destinations when they are de-encapsulated. This forbids us to make fine grained traffic forecasts to undertake routing decisions. There is a whole research field, traffic engineering, devoted to this. Of course, there are as well algorithms able to handle Quality of Service (QoS) requirements. However, many of them may imply bandwidth reservations to ensure certain Service Level Agreements (SLA) at the cost of sacrificing lower priority traffic, or reductions on the quality of traffic, for instance.

The detachment of physical plane and the control or routing one is where the major potential benefits for the PI lay. The time required at each one of the stages of the model presented in Section 4.4 can be forecasted based on historical data. These times may depend on a series of variables, like the type of incoming vehicle (e.g., it does not take the same effort to let a container ship into a port than a cruise), or the amount of cargo. As long as these variables are known in advance, hub visits and goods routing can be optimized.

Table 1: The proposed model is general enough of capture the different operations taking place in any type of hub.

Proposed Model	Seaport	Intermodal distribution centre	Cross-docking classification centre
Docking (T_{dk})	Sea Traffic Management Nautical services (pilotage, mooring, tugging) Gate control	Rail shunting operations Vehicle reception	Vehicle reception
Cargo unload (T_u)	Terminal Cranes (STS, RTG, RMG, SC, etc.)	Cranes (RMG, reach stacker, etc.)	Forklifts Human force
Storage & decomposition (T_{dc})	Bulk, general cargo, ITUs handling Open air - yard /warehouse storage	ITU handling, Decomposition in smaller handling units (PI-container) Open air - yard, Incoming dock - reception area, warehouse facilities	Incoming dock - reception area
Customs clearance	Customs inspection and clearance	N/A	N/A
Reallocation (T_r)	Cranes Internal transport	Cranes Internal transport Conveying units Forklifts	Forklifts Conveying units
Storage & Composition (T_c)	Bulk, general cargo, ITUs handling Open air – yard /warehouse storage	ITU handling, Composition in bigger handling units (ITUs) Open air – yard, Outgoing dock – expedition area, warehouse facilities	Outgoing dock - expedition area
Cargo load (T_l)	Terminal Cranes (STS, RTG, RMG, SC, etc.)	Cranes (RMG, reach stacker, etc.)	Forklifts Human force
Undocking (T_{udk})	Sea Traffic Management Nautical services (pilotage, mooring, tugging) Gate control	Rail shunting operations Vehicle reception	Vehicle reception

Hence, the proposed model acts, first, as enabler for the optimization of hub operations. Modeling the times for each operation allows the hub to preallocate resources for the incoming transports, avoiding unnecessary waiting times and, hence, reducing the turnover time and increasing the hub efficiency.

Second, the model acts as an enabler for the transformation of hubs to hyperconnected PI hubs. PI hubs will offer their platform to both cargo operators and carriers. We envision auctioning-based routing algorithms for PI hubs. On the one hand, logistic carriers would offer their vehicles, with a certain modular capacity, departure time, destination and expected trip duration, at a certain cost. On the other, cargo operators will offer a price for a cargo to be moved across two locations with a certain time and budget constraints. For these algorithms to provide an optimal routing, the data provided across different hubs needs to be uniform, consistent, and accurate. That way end-to-end trips could be coarsely planned based on the already known transport options and adapted on each hop, leading to more dynamic and adaptive logistics.

7 Conclusion

In this paper we have provided an enumeration of the similarities and differences between routers and physical hubs. We have provided a taxonomy for physical hubs that can be mapped to the hierarchical structure of routers in the internet as well as showing the similarities of this structure to that of the world of logistics. Similarly, we have built a general model of operations that, to be best of our knowledge, applies to every hub. This model enables us to define a common language for parametrizing hub operations and mathematically defining new parameters that can be the base for the future routing algorithms in the physical internet. We have provided examples of some of these parameters and shown how they could be computed using the model we propose. Then, we have validated this model with three different types of hub, seaports, intermodal distribution centers and cross-docking classification centers.

Finally, we have open the discussion of how these routing algorithms could be, potentially based in auctioning, which remains in our future work.

References

- Buckley, S., Montreuil, B., & Montreuil, Z. (2017). *Simulation based study of the effect of competition on the operations of hyperconnected crossdocking hubs*. In 4th international physical internet conference (IPIC).
- Chargui, T., Reghioui, M., Bekrar, A., & Trentesaux, D. (2016). *A simulation model to migrate from cross docks to pi-hubs*. In 3rd international physical internet conference (IPIC).
- Colin, J.-Y., Mathieu, H., & Nakechbandi, M. (2016). *A proposal for an open logistics interconnection reference model for a physical internet*. In Logistics operations management (gol), 2016 3rd international conference on (pp. 1–6).
- Drewry. (2017, October). *Container forecaster & annual review 2017/18 (Tech. Rep.)*. European Commission, D. f. M., & Transport. (2017). An overview of the eu road transport market in 2015.
- Hao, G., & Gue, K. R. (2016). *A two-sided, high-density rail-rail hub*. In 3rd international physical internet conference (IPIC).
- Hawkinson, J., & Bates, T. (1996, March). *Guidelines for creation, selection, and registration of an autonomous system (as) (BCP No. 6)*. RFC Editor. Internet Requests for Comments.
- Higgins, C., Ferguson, M., & Kanaroglou, P. (2012). *Varieties of logistics centers: Developing standardized typology and hierarchy*. Transportation Research Record: Journal of the Transportation Research Board (2288), 9–18.

- Huber, S., Klauenberg, J., & Thaller, C. (2015). *Consideration of transport logistics hubs in freight transport demand models*. *European Transport Research Review*, 7(4), 32.
- Kim, N., & Montreuil, B. (2017). *Simulation-based assessment of hyperconnected mixing center capacity requirements and service capabilities*. In 4th international physical internet conference (IPIC).
- McKinsey. (2017, October). *Container shipping: The next 50 years (Tech. Rep.)*. UNCTAD.
- Meller, R. D., Montreuil, B., Thivierge, C., & Montreuil, Z. (2012). *Functional design of physical internet facilities: a road-based transit center*.
- Modulushca. *Modulushca project*. Retrieved from <http://www.modulushca.eu/> (Accessed: 2018-04-23)
- Montreuil, B. (2011). *Toward a physical internet: meeting the global logistics sustainability grand challenge*. *Logistics Research*, 3(2-3), 71–87.
- Pal, A., & Kant, K. (2016). *Networking in the real world: Unified modeling of information and perishable commodity distribution networks*. In 3rd international physical internet conference (IPIC).
- Romstorfer, A., Dörr, H., & Marsch, V. (2017). *Rti capabilities of air cargo transport chains by evaluating processing interfaces and actor's responsibilities*. In 4th international physical internet conference (IPIC).
- Sarraj, R., Ballot, E., Pan, S., & Montreuil, B. (2014). *Analogies between internet network and logistics service networks: challenges involved in the interconnection*. *Journal of Intelligent Manufacturing*, 25(6), 1207–1219.
- UNCTAD. (2017a, December). *Handbook of statistics (Tech. Rep.)*. 2017.
- UNCTAD. (2017b, October). *Review of maritime transport 2017 (Tech. Rep.)*.
- Wetherly, P. (2014). *The business environment: themes and issues in a globalizing world*. Oxford University Press.



Establishing a Physical Internet Test Region – Learnings from ATROPINE

Patrick Brandtner¹, Maria Kalt¹, Michael Plasch¹, Oliver Schauer¹

1. University of Applied Sciences Upper Austria, Steyr, Austria

Corresponding author: maria.kalt@fh-steyr.at

Abstract: *The paper aims to present the learnings of a research project in Upper Austria. Since the beginning of 2016 the ATROPINE (Fast Track to the Physical Internet) partners join forces to establish a Physical Internet (PI) test region. The key contributions of this paper are to identify and demonstrate the challenges of the project partners on the way towards PI. Furthermore, the paper aims to provide and share experiences of a multi-disciplinary approach to PI and a cross-industry setting of the project.*

The ATROPINE consortium consists of several research departments of different disciplines, company partners from trade and producing industries, logistics service providers & IT technology providers and other PI stakeholders like the Chamber of Commerce and the Industrial Association of Upper Austria. The project was funded by the Upper Austrian Government and will be finished by September 2018. At the time of publication of this paper the project team is evaluating the findings of ATROPINE to follow-up on impact, multiplier effect and subsequent actions in the PI test region.

Keywords: *Physical Internet, test region, new business models, project consortium*

1 Introduction

Companies source and sell products globally and their logistics processes change constantly and rapidly. If researchers study these circumstances they usually ask themselves the question: Why is that so and how can we cope with this? Furthermore, we often observe that turbulent markets and the need for responsive capabilities lead to inefficient and unsustainable practices. Especially in logistics, we are aware of the fact, that warehouses are often non-utilized and transport vehicles partially empty. Ballot et al. (2014) described that this happens mainly because of a lack of communication standards and malfunctioning practices between logistics players (2014). Still, inefficiencies are de facto standard and further challenges due to internationalization efforts of new players might even influence future logistics networks (Simmer et al., 2017).

The concept of PI however proposes to eliminate these inefficiencies. Aiming for a radical and sustainability improvement, PI is seen as a hyper-connected global logistics system, enabling seamless asset sharing and flow consolidation (Montreuil, 2012). Consequently, PI will force all stakeholders to invest in awareness, innovation, change management, legislative, standardization and incentives. The European technology platform ALICE (Alliance for Logistics Innovation through Collaboration) has adopted the PI concept and pursues its implementation by 2050. ALICE was set-up to support a broad strategy for the EU-area to push research and innovation efforts in the direction of PI with all relevant logistics and supply chain management issues (<http://www.etp-logistics.eu/>).

These efforts are based on the PI concept and the need for a central approach on logistics and supply network planning, in which producers and logistics service providers collaborate. The ATROPINE consortium also considers this joint approach the only way to reach a more efficient transport and logistics system in Upper Austria.

On the other hand, to date PI efforts often remain theoretical concepts. In order to address this, ATROPINE - funded under the Strategic Program “Innovative Upper Austria 2020” - was set up differently. It unites researchers, industries, logistics service providers, technology partners, intermediary players and policy makers.

The multi-disciplinary and cross-industry consortium aims to establish a PI test region in Upper Austria by 2018. Furthermore, the project team planned to look into at least 4 parts of a PI system – intelligent containers, shared infrastructure, synchromodality and into more efficient approach to the last-mile logistics. This paper summarizes the learnings from ATROPINE. Figure 1 gives an overview about the addresses topics.

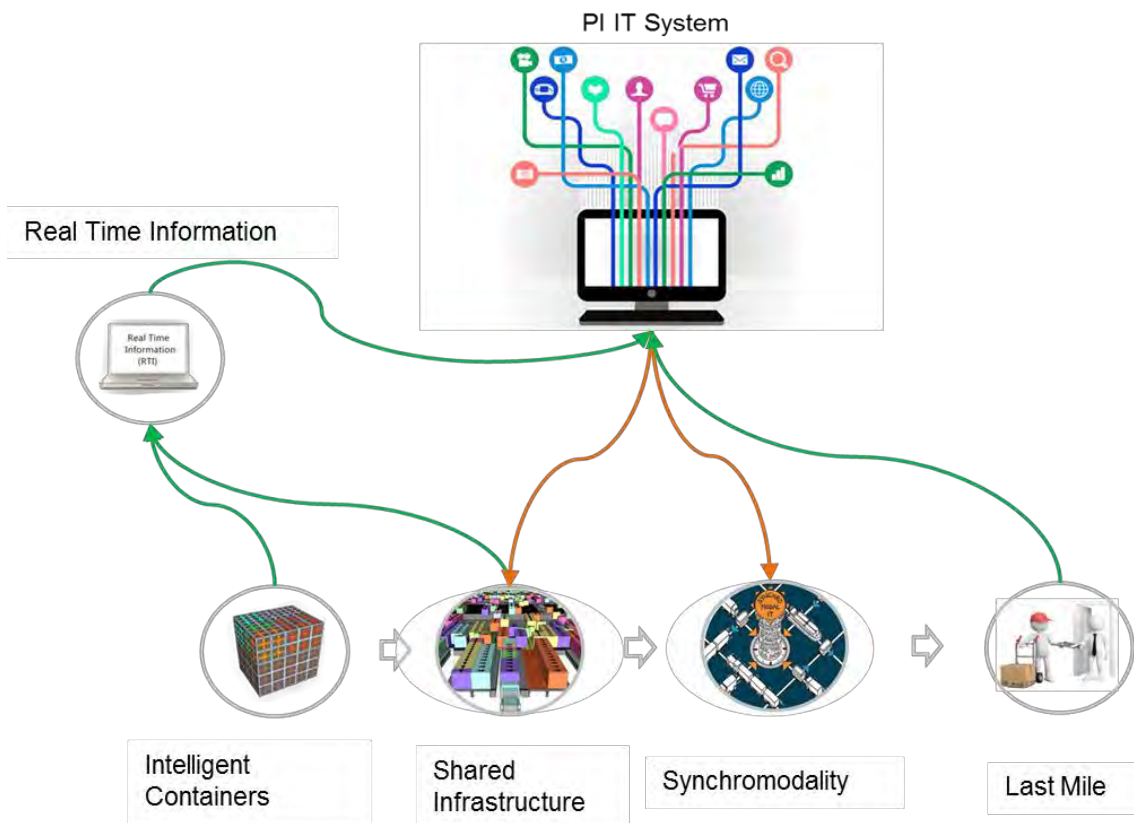

Figure 1: Illustrating the Main Parts of a PI System Addressed Within ATROPINE

2 Problem statement

Upper Austria is an economic area with a strong focus on industry and trade and a high density of logistics service providers. Investments in infrastructure (warehouses, fleets and human resources) are the companies’ daily business. Although there is a strong tradition of industry-related research and a government mandate for fostering cooperation between policy makers, universities and industries there is still a need for new organizational concepts and resources to create value. This drives the underlying research question of this paper: “*What are the key learnings and experiences gained in this PI research project and which recommendations and critical success factors can be derived for future PI activities?*”

The ATROPINE project team considers it as one of the most significant problems, that building awareness for PI related topics and motivating potential partners to become members of a PI network are a real challenge. The reason for difficulties in trying a ‘real-life’ setting derives

from the fact, that the practical implementation of PI in a broader field – e.g. in a cross-industry transport network - and solid evidence for a holistic PI concept are still missing.

Thus, the stakeholders around the ATROPINE project setup were pointing out, that the ability of PI to survive in a real business setting has still to be tested. Company partners in applied research projects however need a setting where the researchers provide tangible advantages for PI shareholders. ATROPINE was set up as one of the few projects within the PI research field in Europe, which tries to combine theoretical research with practical implementation.

The goal of the team was to reach at least some of the relevant elements for a PI system – the most important being the deployment of a PI IT system. Thus, researchers of the University of Applied Sciences Upper Austria – Campus Hagenberg, namely the HEAL group (Heuristic and Evolutionary Algorithms Laboratory) had to design and develop an “intelligent” PI algorithm for the smart matching of supply and demand within the ATROPINE partner network.

From the start of the project onwards the consortium further identified it as a main goal, that ATROPINE has to provide a proof of concept for the functioning of several PI elements. The within the project developed “simulation and optimization model” should therefore not use dummies, but real historical data. That means that the data base was provided by the project partners and is based on actual transport requirements and capacities. Thus, the ATROPINE simulation and optimization results are able to present significant effects, which are more close to reality than theoretical assumptions and validate the above mentioned PI approach.

3 Current Results

The project ATROPINE is currently arrived in phase 3, which means that the project management concentrates on evaluating the findings, summarizing the results and working on recommendation for the company partners and further PI projects.

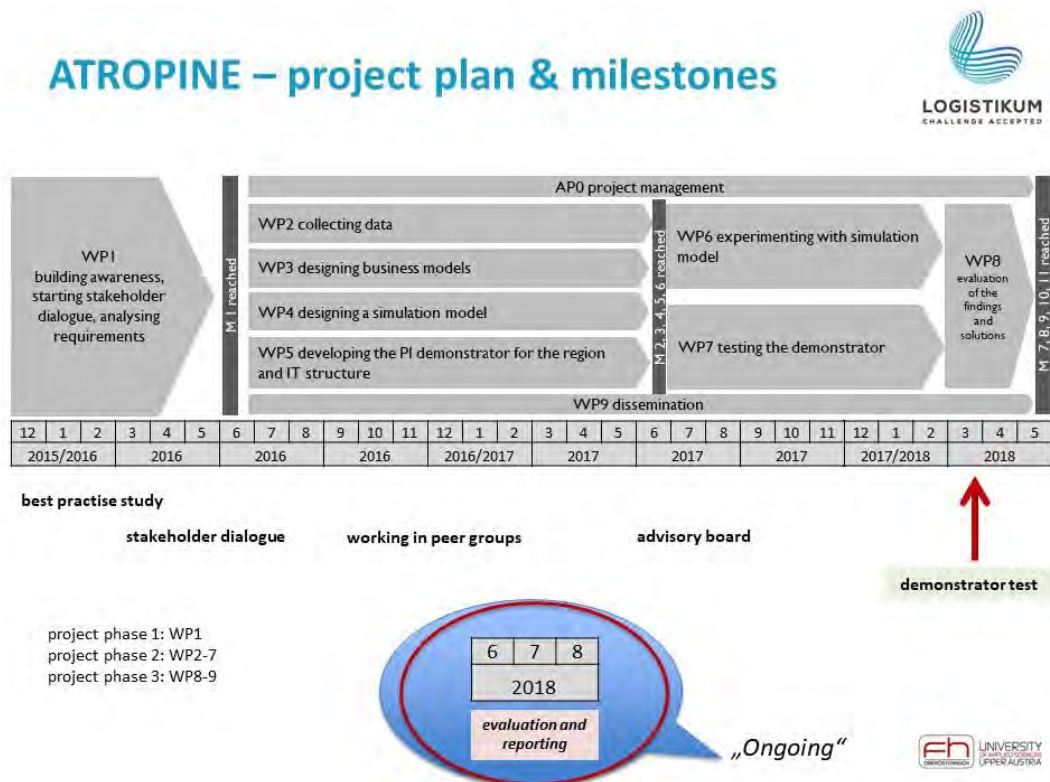

Figure 2: ATROPINE project plan

3.1 Design of the platform

A working group consisting of researchers from the Johannes Kepler University in Linz/Upper Austria (department WIN-SE), the University of Applied Sciences Upper Austria and company partners within the IT sector developed basic requirements for “shippers” and “transporters” on a PI platform e.g. the need for user profiles, a direct interface and the opportunity to evaluate transports within the PI network. In addition to the transport proposals displayed by the system, platform users should also be able to use order-related value-added services (e.g. to compare and conclude general and long-term insurances).

3.2 Legal recommendations

The peer group ‘Legal Framework’ accompanied and consulted the project team during the whole process. Being familiar with transport management topics and deeply involved in the specific ATROPINE setting, the ‘Legal Framework’-group developed the so-called PI model terms and conditions, which are closely related to the current business model and aim at facilitating its implementation. In addition, the peer group elaborated a sample contract for cooperation within a potential PI partner network.

3.3 Technical example of a PI implementation

In addition to the simulation of the potential benefits of a PI system and model region in Upper Austria, the ATROPINE project also dealt with a so-called ‘intelligent container’, a charge carrier equipped with radio and sensor technology, which could record quality and general monitoring data for the loaded goods and transfer them for further and optimized planning.

3.4 Results of the demonstrator tests

The evaluation of a simulation with data from shippers by the end of 2017 revealed a significant optimization. The total mileage in the ATROPINE network was reduced by up to 25% and costs by up to 15%. For the Upper Austrian model region, this means: more bundling potential leads to more optimization potential and causes lower costs. As a result, this also means less CO2 emissions. For the ATROPINE project design, the consortium consciously chose shippers from different industries with different requirements for transport. This resulted in higher costs for some of the partners. In follow-up activities, a fair gain- and loss-sharing must therefore be developed. During the second demonstrator test in March 2018 the project team got too few shipments in the selected period and with the restrictions on the postal code area and ‘dry goods’, in order to read a clear result.

But in any case, it can be said that larger networks and collaborations in the overall system lead to significant improvements and that a model based on the Physical Internet would be seen as a positive location factor. In order to prepare ATROPINE project results and to derive recommendations for action and to present them to a broader public, the project team uses the Austrian Logistics Day (held on 12th June in Linz with about 800 participants) to present the results.

4 Research background and methodology

The main goal of ATROPINE is to bring PI in practice. Sub goals are that this has to happen within a defined “test region” and the project has to derive key learnings that explain PI conditions. Definitely, the consortium was aware of the fact that making PI a reality will require radical changes with respect to roles and responsibilities of stakeholders. In the first stage of

the project the researchers concentrated on a sound screening of “best-practice-cases” of certain PI-aspects like smart and standardized containers, open supply webs and sharing concepts.

More than 200 examples were found all over the world and in a next step they were discussed within a “stakeholder dialog” in Upper Austria. The result was that in spring 2016 the project team agreed on the fact that PI needs practice in cooperation, asset sharing and transparency across company borders and within a whole region. ATROPINE is therefore one of the first multi-disciplinary and cross-industry project that pursues the PI vision. The project design and goals focus on:

- Analyzing companies’ flow of goods data within the ATROPINE network
- Deriving potential and optimizing - if already existing - networks
- Demonstration and proof-of-concept of PI
- Framework conditions for new PI business models
- Communication and knowledge transfer to other domains
- Increasing research capabilities of the ATROPINE partners
- Maintaining and further developing a PI network

4.1 Consortium and partners

The heterogeneity of organizations forming the ATROPINE consortium is considered a central aspect and covers all roles, goals, challenges and standpoints in networks. The project combines the input of five Upper Austrian research partners (3 University institutes, 1 IT service company and 1 network partner) and 14 industry partners. These consortium members are aware that within ATROPINE they are expected to share data. However, within the project period and in practice this fact alone leads to certain challenges which will be described later in this paper. Definitely, the ATROPINE partners want to explore existing technologies and build up expertise in the PI field. Together they design new logistics solutions and business models for future developments.

4.1.1 Research partners

The LOGISTIKUM, a department of the University of Applied Sciences Upper Austria designed the core concept of the ATROPINE project as lead of the consortium. Together with four other research partners - Hagenberg, JKU, RISC Software and VNL - the project proposal was presented to the Upper Austrian government.

Research funds from the strategic program “Innovative Upper Austria 2020” were granted upon condition that Upper Austrian core companies were included in the project and deeply involved in the development of so-called “recommendations for action” on the way to PI to meet EU-goals for reducing emissions of goods transport. This goal - a more sustainable and efficient transport and logistics system - is considered to be a positive factor for growth within a business location. An applied research approach is a common factor of the ATROPINE research partners.

4.1.2 Company partners

The ATROPINE company partners were approached within a “stakeholder-dialogue” during the project design and the first project phase. A goal of the project manager was to set up the first multi-disciplinary and cross-industry PI project and therefore certain companies were addressed. Another focus was set upon best-in-class partners and early-movers considering innovation and technology orientation.

Four company partners were convinced by the PI idea and success factors and also able to deliver data about goods that could be transported in the PI model region which should be defined by ATROPINE. They were complemented by three logistics service providers which

were able to share means of transportation and personal contribution and expertise. To support the integrations of systems five IT and technology providers were invited to join ATROPINE.

4.1.3 Policy partners

To be able to balance different interests the ATROPINE project team was completed by the contribution of the Upper Austrian Chamber of Commerce. Furthermore, the Industrial Association of Upper Austria stated its interest in the PI research field in general and in the ATROPINE findings.

4.2 Task field structure

By structuring the project into three pillars the consortium clustered competencies and pursued sub-goals.

4.2.1 Peer group ‘legal framework’

The peer group ‘legal framework’ was built to evaluate legal framework conditions and guidelines to setup a PI concept. The implementation of a PI system in the ATROPINE model region requires constant restructuring, further development and improvement of existing logistic concepts and business model settings. This makes a simultaneous and comprehensive examination and analysis of the legal requirements essential. The project consortium agreed on the fact that it is important to secure the necessary changes of existing logistic systems. The ATROPINE consortium therefore defined a sub goal: The broad restructuring of the entire logistic sector on the way to implementing a PI vision, has to take place in accordance with the legislative system to make sure that there are no barriers and constraints for PI.

Responding to this necessity and to the request of the project partners, the peer group “Legal Framework” was established. In coordination with the whole consortium, the peer group “Legal Framework” worked to define clear standards necessary for the smooth cooperation between industry partners, logistic service providers and providers of value added services.

The peer group had the task to examine the current legislative environment as well as establish and evaluate the legal framework, thus defining the borders and conditions for PI business models and identifying potential obstacles for the implementation of the PI in the specified model region from a legal point of view. First of all, the peer group had the task to identify possible PI aspects, which are currently not covered by the law.

4.2.2 Peer group ‘business model’

The second cluster that was built - the peer group ‘business model’ - had to find operational structures which allow PI collaboration and to develop business model concepts for users and investors. The cross-sector cooperation and mutual use of existing infrastructure and transport resources between industrial partners and logistic service providers requires a development of a new business model, which is the primary goal of this ATROPINE working group. The members try to integrate all components of the PI concept in the best possible way and give a direction for practical implementation of the model.

The new developed business model tries to facilitate a smooth cooperation between the network partners, based on integration, improved communication, digitalization of logistic processes and sustainable use of existing resources as well as a transparent cost structure and fair distribution of profits. It is the way to an open cooperation in a cross-sector logistic network, which makes not only the economic potential of the PI - cost saving, reliability, operating efficiency, profitability, access to new markets and customers - but also the social and environmental advantages of the PI concept tangible.

4.2.3 Peer group ‘modelling, interaction, simulation and optimization - MISO’

The peer group MISO (modeling, interaction, simulation and optimization) is divided in two parts. HEAL (Heuristic and Evolutionary Algorithms Laboratory) group at the University of Applied Science Hagenberg and RISC Software are responsible for the MISO I working packages - including optimization and simulation of the data. MISO II consists of a group of scientists at the department for Software Engineering at the Johannes Kepler University of Linz and includes research regarding the necessary PI hardware and the continuous development of the PI container technology, in order to automate, improve and further accelerate logistic processes.

The main target of the MISO peer group is the development of an overall concept for operating a demonstrator, including an IT reference model. The demonstrator serves as a “proof of concept” of the PI concept in the model region, presenting important insights for future research and identifying challenges on the way to implementing the PI vision on a broad scale. The simulation and optimization model, developed by the MISO group is very important for estimating the new PI business model in the “real-life” demonstrator setting.

5 Key recommendations and learnings

As this research is still in progress, the paper presents a part of the findings and a preliminary table of key experiences and learnings. A significant portion is not yet available but the final insights will be presented at the IPIC 2018 in June in Groningen. By now, we can summarize that a heterogenic partner network is just as much a challenge: different goals, market requirements and strategies massively stress current business models and call for new approaches.

ATROPINE took this complex structure and a mix of sectors into account and gave particular attention to trust building, transparency, and emotions. Despite all these challenges the ATROPINE project team was able to identify bundling effects in the test region, especially among the logistic providers, which will definitely lead to further PI efforts:

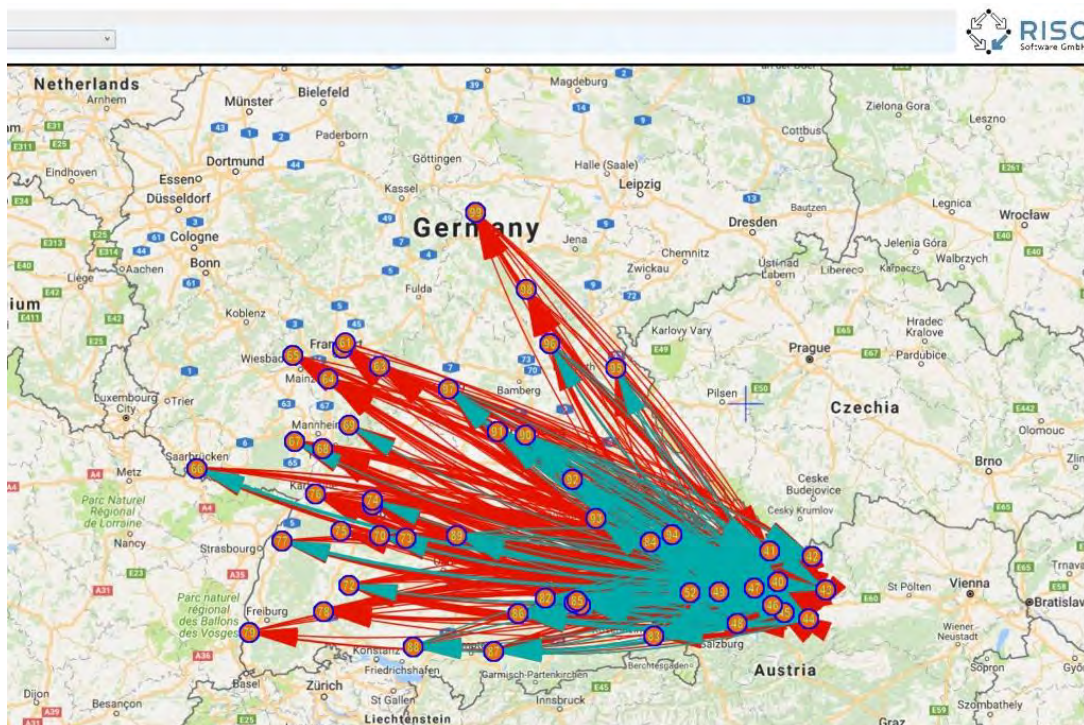

Figure 3: ATROPINE bundling effects derived from 2016 data by the MISO peer group

The results in the context of the ‘smart container’ can be summarized that technology evaluation still has to be continued since all variants are considered as too expensive for the ATROPINE consortium partners. However, there was expressed a strong commitment to invest in innovation and to support technologies of the future.

Further key learnings were derived:

- PI is a network of networks and requires interconnectivity and willingness to cooperate
- PI requires a new kind of supply chain visibility
- PI is based on the digital internet and requires open and consistent protocols
- Existing applications and research knowhow paired with entrepreneurship are a boost for PI

Nevertheless, the underlying project is considered as a first major step dealing with the implementation of PI in a model region like Upper Austria. A test in a theoretical demonstrator with real business-data from March 2018 showed a potential of savings up to 15% of costs and up to 25% of driven kilometers.

The ATROPINE consortium agreed to further join forces to be able to test the data model in a real transport setting. One of the major challenges to do so is considered to be trust. Therefore, it will be essential to assure PI partners that the system can be trusted as a whole, that data will be safe and that a PI collaboration will be stable. The ATROPINE partners furthermore agreed that by adding more players, it will be possible to scale up efforts. The project showed that PI awareness in companies should be raised and collaboration between actors intensified. In order to develop consistent and impactful solutions towards PI in reality, the following research efforts of the PI community in Upper Austria is committed to work on the model and further PI aspects.

One key learning, however, from the practical implementation in the test region was, that the cross-industry approach, being an innovative idea, was rather difficult to deal with in practice. As long as the PI idea is not established in a broader field, some of the partners would recommend to start implementation within a homogeneous network in order to facilitate smooth cooperation within partners and increase potential for bundling of transports and CO2 reduction.

In the last phase of the project - from May to August 2018 - the ATROPINE team will comprise further conclusions about possible future PI project structures and about strategies to deal with the challenges. The last step of ATROPINE is to publish key recommendations and inform Upper Austrian companies about PI to broaden the basis for future PI research projects.

References

Ballot, E., Montreuil, B. and Meller, R.D. (2014), *The Physical Internet: The Network of Logistics Networks*, La Documentation Française, Paris.

ETP-Alice: Alliance for Logistics Innovation through Collaboration in Europe, available at: <http://www.etp-logistics.eu/> (accessed 20 February 2018).

Montreuil, B. (2012), *Physical Internet Manifesto: Transforming the Way Physical Objects are Moved, Stored, Realized, Supplied and Used, Aiming Towards Greater Efficiency and Sustainability*. CIRRELT, Quebec.

Simmer, L., Pfoser, S., Grabner, M., Schauer, O. and Putz, L.M. (2017), “From horizontal collaboration to the physical internet – A case study from Austria.” *International Journal of Transport Development and Integration*, Vol. 1 No. 2, pp. 129-136.

Acknowledgements

This work has been funded by the strategic program 'Innovative Upper Austria 2020' of the Upper Austrian Government.

Urban Large-Item Logistics with Hyperconnected Fulfillment and Transportation

Nayeon Kim^{1,4}, Nitish Kholgade^{1,4} and Benoit Montreuil^{1,2,3,4}

1. Physical Internet Center
2. Supply Chain and Logistics Institute
3. Coca-Cola Chair in Material Handling and Distribution
4. H. Milton Stewart School of Industrial & Systems Engineering
Georgia Institute of Technology, Atlanta, United States
Corresponding author: nkim97@gatech.edu

Abstract: *This paper investigates the potential of a Physical Internet (PI) based hyperconnected fulfillment and delivery system in a congested urban area for improving last-mile delivery of large items with time-window requirements. Scenarios for a model city, representing various systems from a current dedicated system to a hyperconnected system with openly shared fulfillment centers and a network of PI hubs, are constructed and evaluated using agent-based simulation. Results demonstrate the potential of a hyperconnected system in terms of efficiency, sustainability and service capability, notably with up-to-50% reduction in travel miles, fuel consumption, and emission of greenhouse and with average delay time reduction of more than 60%.*

Keywords: *Physical Internet; Large-Item Logistics; Hyperconnected Transportation; Hyperconnected Fulfillment and Distribution; Last-Mile Delivery; City Logistics; Agent Based Simulation; Open Asset Sharing; Urban Fulfillment Center; Logistics Hub*

1 Introduction

This paper addresses urban fulfillment and last-mile delivery, most costly operations that often create economic, environmental and social issues such as air pollution and traffic congestion, while being critical to customer experience performance, especially when delivery time windows and/or white glove services are required. In the last decade, urban logistics has become a highly researched area, as reported by Taniguchi et al. (2014). Boyer et al. (2009) notably showed that efficiency of last mile delivery decreases with less customer density and shorter delivery time windows.

In recent years, there have been two transformative phenomena: (1) growing customer expectations for faster and punctual deliveries involving precise delivery time windows, which make fulfillment and delivery operations even more complex and costly; and (2) growing urban population, with at the apex a number of megacities. At the extremes, the combination of these phenomena induces either a loss of efficiency due to lower potential for demand flow consolidation when aiming to achieve high delivery service levels, or loss of customer satisfaction and/or sales when unable to meet customer expectations due to inadequate operational capability. The need for improving last-mile operations is thus widely recognized, especially in large urban agglomerations.

This paper focuses on urban fulfillment and delivery of large items such as furniture and large appliances. Such large-item delivery contrasts with parcel delivery, as it typically requires larger trucks, faces sparser delivery points and engages in more intimate white-glove services. Also, these delivery vehicles tend to be parked by the curbside longer while the items are being delivered and installed at the delivery location, creating highly visible traffic congestion issues.

Current urban delivery of large-items is mostly built around retailer-dedicated logistics systems. Each retailer has its own website and/or store(s); its own fulfillment and/or distribution

center(s); and its own or contracted dedicated fleet of vehicles and team of delivery/installation persons. Retail stores are mostly dedicated to showcasing the appliance and furniture portfolio, with deliveries to clients being done from a fulfillment center, itself supplied from a distribution center or directly from suppliers. Delivery operations of each retailer are essentially based on optimizing (1) the set of orders promised to be delivered in each day and/or time window within a day, and (2) the daily routing of its fleet from its fulfillment center(s) to deliver the promised daily orders.

The recently introduced Physical Internet (Montreuil, 2011; Montreuil et al. 2013), with its set of concepts and principles, opens a new mindset that breaks away from the dominating current dedicated approach. As defined by Montreuil (2015), the Physical Internet is a hyperconnected global logistics system enabling seamless open asset sharing and flow consolidation through standardized encapsulation, modularization, protocols and interfaces. The Physical Internet is defined as a hyperconnected system as its components (agents, things, etc.) are intensely interconnected on digital, physical, operational, business, legal and personal layers across multiple parties and modes, ultimately anytime, anywhere.

The paper investigates whether a hyperconnected large-item logistics system built according to Physical Internet concepts and principles can improve large-item fulfillment and delivery in urban areas, using scenario analysis conducted on an agent-based discrete-event simulator. Figure 1 schematically contrasts the current dedicated system and the hyperconnected system investigated in the paper. On the left, a model city is conceptually described as a grid where 4 retailers are serving their customers independently from their own fulfillment center (FC) located each edge of city perimeters. The retailers and corresponding customers are color coded. On the right, the FCs previously owned by each retailer are openly shared so each retailer deploys inventories among the four of the FCs. Nine PI hubs are located in the city so the products are first delivered to the PI hubs (represented in dotted line) and customers are served from the PI hubs (represented in a solid line). All the routes are shared routes in the hyperconnected system.

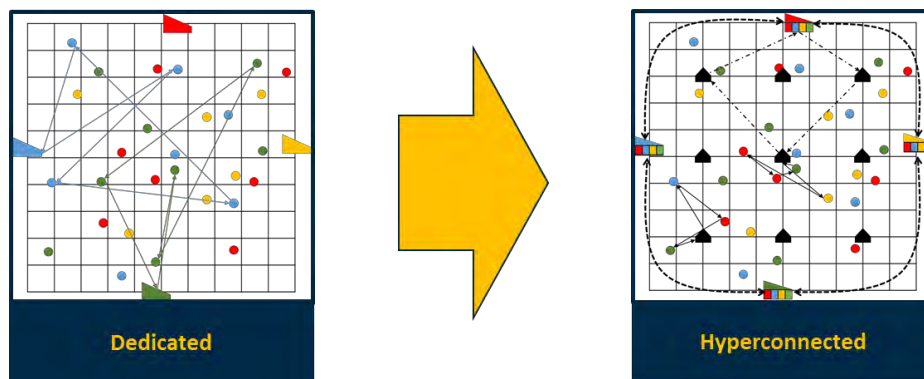

Figure 1: From a dedicated urban logistic system to a hyperconnected system

The paper is structured as follows. Section 2 reviews the pertinent literature and positions the contribution of the paper. Section 3 explains the methodology, the simulation structure, the scenarios, and key performance measures of comparison. Section 4 reports the experimental results while section 5 concludes the paper with synthesis and insights.

2 Literature Review

This paper aims to show the potential of a hyperconnected supply chain for improving last mile delivery with time window of large items in urban area. We categorize the literature reviewed in the paper to urban logistics and physical internet. We also present relevant literatures on delivery with time windows.

City logistics has been heavily studied in the last decade. Taniguchi et al (2014) provides an extensive review of such studies. Diverse approaches have been proposed to improve city logistics such as better routing or time restriction, and there have also been movements highlighting the impact of collaboration between companies on city logistics. For example, many scholars have studied the impact and operation of urban consolidation centers (UCC), also named city/urban distribution centers (CDC/UDC) or freight consolidation centers (FCC), which have been implemented in some cities (BESTUFS, 2007; Van Duin et al, 2010; Allen et al, 2012). Urban consolidation centers enable collaborative transportation in a city by consolidating inbound freight flows to an urban area. However, the level of collaboration or consolidation achieved through traditional approaches hardly reaches the level of connectivity anticipated in a hyperconnected logistics system, which restrains the achievable improvements only to local optima.

Key to the Physical Internet, open asset sharing and flow consolidation (Montreuil, 2015) can be applied to city logistics as proposed by Crainic and Montreuil (2016) and Bektas et al (2017) who have addressed Physical Internet based city logistic system. Crainic and Montreuil (2016) notably extended the two-tier hierarchical urban delivery system of Crainic et al. (2004) exploiting satellite centers to a multi-tier multi-party meshed network, exploiting a wide variety of PI-hubs generalizing the earlier satellite centers.

Goyal et al. (2016) and Kim and Montreuil (2016) were first to address hyperconnected logistics of large items in urban areas. Goyal et al. (2016) assessed through a routing-focused simulation experiment the significant improvement potential (40% in the studied context) offered by hyperconnected transportation of large items given shared distribution centers, assuming 100% availability of products at each shared facility. Kim and Montreuil (2016) extended this assessment thread by combining hyperconnected transportation and distribution. They reported an agent-oriented simulation-based experiment where the 100% availability hypothesis of Goyal et al. (2016) was removed, explicitly dealing with the replenishment of shared fulfillment centers and the dynamic deployment of products among these facilities, notably demonstrating the achievability of the 40%-range improvement potential while taking into consideration both routing and inventory deployment decisions.

This paper is positioned as an extension of the works of Goyal et al. (2016) and Kim and Montreuil (2016), adding distinctive value by (i) comparing more diverse and comprehensive scenarios towards hyperconnected logistics system as will subsequently be made explicit, (ii) incorporating traffic and time windows into the routing and inventory deployment modeling, and (iii) exploiting an extended set of key performance indicators in terms of efficiency, profitability, sustainability and capability.

One of the main methodological challenges in this study is routing with time windows (TW). Vehicle routing problem with time windows (VRPTW) is a well-known problem and there is a plethora of heuristics proposed in the literature. For example, Solomon (1987) proposed several construction heuristics, the most successful being an insertion heuristic essentially working as follows: at any position of a given route, insert if feasible the new customer among unrouted customers that maximizes distance and time savings as opposed to direct serving of the chosen customer, with initial routes constructed by choosing an unrouted customer with the latest feasible time window. Campbell and Savelsbergh (2004) concisely summarize information to be maintained, route updates, and route finalization for VRPTW with insertion heuristics. They pointed out that pushing delivery schedules to the latest possible minimizes waiting time of any feasible route. The route construction heuristic with time window used in this paper is a variation of the insertion heuristic described in Solomon (1987), exploiting the observations of Campbell and Savelsbergh (2004) on minimum waiting time.

3 Methodology

We have conceived and built an agent-based discrete-event simulator to evaluate the efficiency of distribution/fulfillment networks and logistic operation policies for last-mile delivery that are gradually moving from a current dedicated system towards a hyperconnected system.

This section describes the structure of the simulator, the nature of the simulated scenarios, the key performance indices (KPIs) to evaluate the simulation results of each scenario.

3.1 Simulator structure

An agent-based discrete-event simulator is built on a model city designed to be used as a simulation testbed. A simulator, especially based on the combination of discrete-events and agent-based simulation principles and techniques, is one of the most effective tools to evaluate the impact of a hyperconnected supply chain or logistics system. This is due to its ability to model operations of each player and complicated interactions between the players under stochastic environments which can often be too complex to solve with optimization models. It enables us to experiment various scenarios, from basic to innovative, and to even observe the efficiency of each system over time.

Figure 2 is the conceptual diagram of the simulator describing key agents, objects, and interactions between them through information and physical flows.

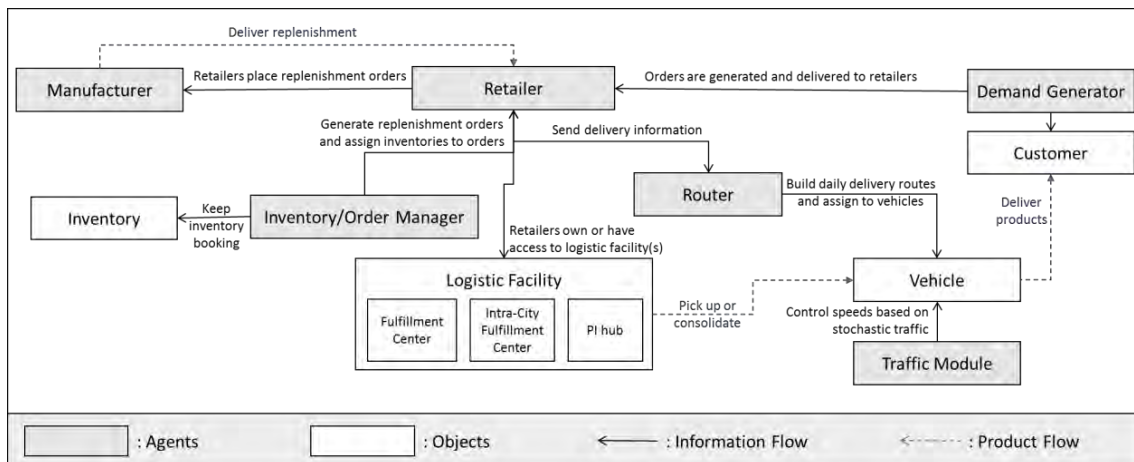

Figure 2: Conceptual diagram of the agent-based discrete-event simulator for large-item urban logistics

The simulator recognizes two fundamental types of urban facilities: fulfillment centers (or simply fulfillers, F) and hubs (H). Fulfillment centers store goods not yet ordered by customers so as to be able to fulfill customer orders. Hubs enable asynchronous consolidation, crossdocking and transshipment of goods. Both fulfillment centers and hubs can be differentiated according to their location, as peri-urban (P) or intra-city (I), and according to whether they are dedicated (D) to a specific retailer (or group of) or openly shared (S). For example, SIF characterizes a shared intra-city fulfiller while a DPF characterizes a dedicated peri-urban fulfiller. In general, PFs have larger capacity than IFs due to lower land cost, so IFs generally are limited to fulfill a limited set of top sellers.

The exact operation of manufacturers is not explicitly modeled. However, each manufacturer may have a distinct replenishment lead time, notably depending on whether it is based on make-to-stock or make-to-order, and on its proximity to the city. The simulator enables to model a smart supply chain where the manufacturers deliver to any facilities in the city based on the request of retailers or even deliver to multiple facilities to balance inventories among the

facilities when retailers have access to multiple facilities in the scenarios with a hyperconnected distribution.

The snapshot of the model city is shown in Figure 3. In the illustrated instantiation, there are four retailers serving the city. Each originally has a single DPF from which customers are delivered. In Figure 3, the retailers are color-coded in red, blue, green, and yellow. Suppliers to the retailers are located outside of the city, but their displayed location is symbolic and do not represent their actual longer distance to the city.

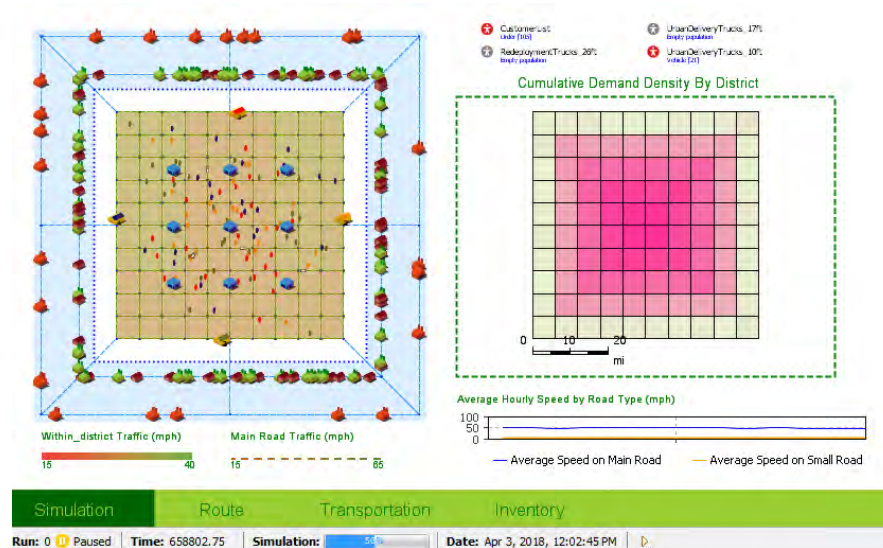

Figure 3: Simulation snapshot of scenario 8 - illustration of the model city, logistic facilities, customers, traffic, and demand distribution

The city consists of districts linked by a main road network. The districts are represented as basic square areas of the grid while the roads are represented by edges of the grid. The main road network represents highways or boulevards. Vehicles move along the main road network when moving between districts, and move along an implicit small road network within districts, whose modeling is simplified assuming they travel in straight Euclidean or rectilinear line. The speed limit on inter-district roads and on intra-district roads are different, set by the modeler (e.g. 50 vs. 30 mph), while the actual speeds varies by hour and day on each road. During a simulation, each road and district is colored on the simulator's animation display according to the traffic at the moment. In Figure 4, typical weekday's or weekends' average speed by hour of the day on each type of road is shown.

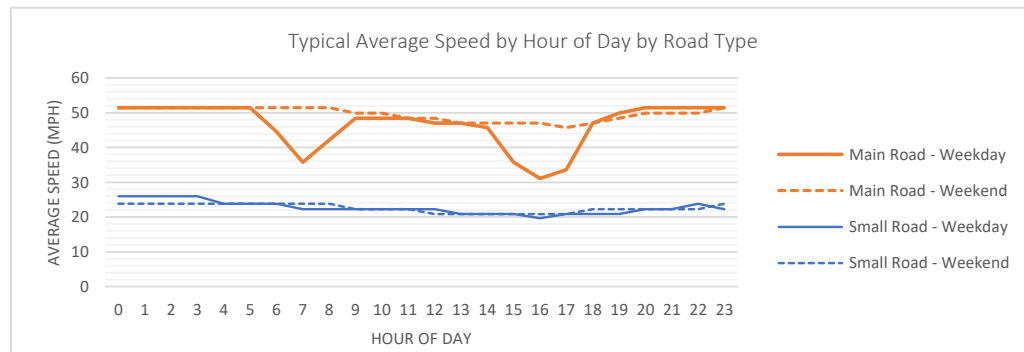

Figure 4: Average speed by hour of the day in a typical weekday/weekends on main and small road

The simulator allows to use different types of vehicles for different types of deliveries. In this paper, we assumed 26-foot trucks for shipments from fulfillers to hubs or between fulfillers, 17-foot trucks for deliveries from fulfillers to customers, and 10-foot trucks for deliveries from

hubs to customers. We further assumed that 26-truck shipments were to be scheduled very early mornings when there is only little traffic on the roads.

At order arrival, each customer is assigned to a logistic facility based on dedicated vs. shared mode, geographical proximity and inventory availability. When shared hubs (SHs) exist, customers are simply assigned to the closest SH. Routes are constructed based on the assignments using a simple heuristic based on the insertion heuristics described in section 2 to minimize the expected waiting time. An initial routes is created by picking an unrouted customer who has the latest delivery time window. Unrouted customers are sequentially added to the front of the current route, if feasible, in a way to have minimum increase in total route time. The delivery schedule is finalized by scheduling delivery at the latest possible time from backwards. In actual operation, when delivery is completed at a location, the assigned vehicle leaves toward the next destination as soon as possible to minimize delay.

In this study, we assume center-concentrated demand distribution over the city: there is more demand in the center of city than in the peri-urban area. On the right side of the model city in Figure 3, an illustrative cumulative demand distribution by district is shown.

3.2 Scenario Design

There are two complementary threads towards urban hyperconnected logistic system: delivery and fulfillment. Hyperconnected fulfillment enables smart and flexible deployment of physical products through an open distribution facility network. The operation of Fulfillment by Amazon or Flexe.com can be good example of transforming towards hyperconnected distribution from dedicated distribution. Hyperconnected delivery and transportation enables more efficient movement of goods by better consolidating and therefore better utilizing vehicle capacity through integrated multi-party multi-modal routing and dynamic consolidations at PI hubs.

Respecting these two threads, the reported simulation-based experiment is constructed around scenarios combining the threads. Along the delivery thread, there are three alternatives:

- (1) Deliveries done independently by each retailer by routing its fleet of vans;
- (2) Deliveries openly shared among retailers by routing multi-retailer vans;
- (3) Deliveries openly shared among retailers, exploiting SIHs for openly consolidating flows, with products sent to the hubs in larger vans from the fulfillment centers and sent from hubs to customers in smaller trucks.

Along the fulfillment thread, there are also three alternatives:

- a) Products of a retailer are stored in its DPF;
- b) Products from any retailer can be openly stored in any of the SPFs;
- c) Products from any retailer can be openly stored in SPFs and/or SIFs, with the latter being more expensive and restricted than SPFs.

Note that scenario 1a corresponds to the typical current operation: retailer-independent dedicated delivery and distribution.

Different combinations of delivery threads 1, 2 and 3 and distribution threads a and b have previously been investigated in exploratory mode by our team, as reported in Goyal et al. (2016) and Kim and Montreuil (2016), yet here reported on a more complex context involving:

- i. Stochastic daily demand occurring at specific locations and times, with each customer specifying its desired X-hour time window;
- ii. Travel time across the city is traffic dependent, this stochastic traffic is time-of-day dependent, and delivery routes are constructed attempting to take into account the expected time-dependent traffic condition.

Scenarios are constructed by combining different alternatives from delivery and fulfillment threads. Table 1 lists and describes the sample scenarios selected to represent gradual transformation of fulfillment and last mile delivery from dedicated to hyperconnected.

Table 1: Description of sample scenarios varied by fulfillment and delivery type with operation type of each facility and delivery

Scenario ID	Scenario Type		Operation Type			
	Fulfillment	Delivery	Peri-urban Fulfillment Center (PF)	Intra-city Fulfillment Center (IF)	Shared Intra-city Hub (SIH)	Delivery
1	Dedicated	Dedicated	Dedicated	-	-	Dedicated
2	Hyper-connected	Openly-shared	Openly-shared	-	-	Openly-shared
3			Dedicated	Openly-shared	-	Openly-shared from SIF
4			Openly-shared	Openly-shared	-	Openly-shared
5	Dedicated	Hyper-connected	Dedicated	-	Single	Hyperconnected
6			Dedicated	-	Web	Hyperconnected
7	Hyper-connected	Hyper-connected	Openly-shared	-	Single	Hyperconnected
8			Openly-shared	-	Web	Hyperconnected

In addition, Figure 5 illustrates logistic network topologies and last-mile operations of some investigated scenarios, where logistic facilities and delivery locations are identified, and some potential last-mile routes are displayed.

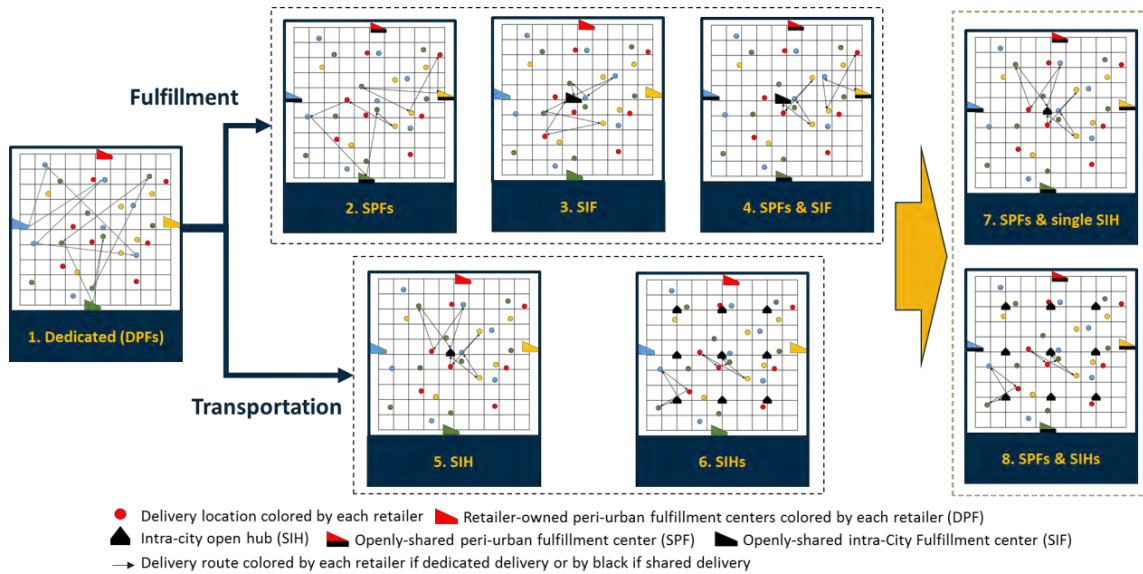

Figure 5: Sample scenarios illustrating the gradual transformation from dedicated to hyperconnected logistic structure and routes with delivery time windows

Thread alternative combination 1a corresponds to scenario 1 which represents the typical current operation: retailer-independent dedicated delivery and distribution. Therefore, each peri-urban fulfillment center (DPF) and each route is dedicated to exactly one retailer. It forms the baseline for comparing the other more hyperconnected scenarios.

Thread alternative combination 2b corresponds to scenario 2. It exploits SPFs, allowing any retailer to smartly deploy its inventory in any of the SPFs. This enables retailers to increase proximity to potential customers especially when the SPFs are located in distinct areas of the city, as assumed in this study. At the same time, however, customers may not be always served from the closest SPF if no inventory is available at the preferred SPF.

Combination 1/2c corresponds to scenario 3. Here, a retailer can store its products either in dedicated PFs (DPFs) or in shared IFs (SIFs). Note that because of the rent and limited land in the center of the city, the capacity of SIFs is limited and storage cost is more expensive compared to the capacity of SPFs, inducing the retailers to store in them only popular and high-selling products. Delivery routes from SIFs are shared multi-retailer routes but the routes from DPFs are dedicated to their single retailer.

Combination 2bc corresponds to scenario 4. This scenario can be seen as the combination of scenario 2 and 3. All routes in scenario 4 from SPFs and SIF are shared multi-retailer routes.

Combination scenario 3a is named as scenario 5. In this scenario, storage space is not shared by the retailers, but each retailer ships in the morning products to be delivered to customers during the day to a single shared intra-city hub (SIH) located at city center and all the shipments are consolidated at the SIH and delivered in a shared multi-retailer route. Since routes from the SIH tend to be shorter due to increased proximity to customers and delivery density, smaller delivery vehicles are used for the last mile delivery from the SIH to customers. Routes from DPFs to the SIH are single-retailer routes and routes from the SIH to customers are multi-retailer routes.

Scenario 6 is another variation of the thread combination 3a. Unlike scenario 5, however, now a network of multiple SIHs are used instead of a single SIH at the center of the city. Customers are served from the nearest SIH and retailers ship products to assigned SIHs in the morning. In scenario 6, routes from DPFs to SIHs can be multi-stop routes.

Combination thread 3b corresponds to scenario 7. It can be seen as a mix of scenarios 2 and 5. Peri-urban fulfillment centers are now openly shared, so they are SPFs in this scenario. Routes from SPFs to hubs and/or customers can be multi-retailer routes.

Scenario 8 can be seen as a variation of scenario 7 or combination of scenario 2 and 6, as it relies on SPFs and multiple SIHs.

3.3 Key performance indices

It is critical to use proper key performance indices (KPIs) to evaluate scenarios correctly. Inappropriate KPIs can lead to wrong conclusions. We categorize the KPIs into two major groups by the type of impacts they measure: economic impacts, environmental impacts and social impacts (here limited to service level capability)

Several KPIs can measure economic impacts. The most straightforward KPI is the total induced cost, yet given that is hard to assess comprehensively, we have relied on constituting surrogates such as travel distance, driving hours, labor hours and fuel consumption. Driving hours measure the time delivery vehicles spent on traffic-congested roads, whereas labor hours measure the time vehicles were in operation.

The social impact on service level capability can be measured by punctuality with respect to time windows. When delivery time windows are required, delays play a critical role in customer experiences, which can result in delivery postponement and rescheduling or even lost sales, and overall dissatisfaction in the urban population.

To measure environmental impacts, we use greenhouse gas (GHGs) and toxic gas emissions. More specifically, we measure the emissions of carbon dioxide (CO₂), sulfur dioxide (SO₂), and nitrogen dioxide (NO₂) caused by delivery operations. Besides these, we also measured the emission of fine particles, especially the atmospheric particulate matter PM_{2.5} that can cause severe respiratory problems through consistent exposure as it can penetrate into the lungs during inhalation (Xing et al., 2016). To estimate the emission level, we used the Motor Vehicle Emission Simulator (MOVES) software produced by the US Environmental Protection Agency

(EPA), which estimates the emissions based on number of vehicles, vehicle types, road types, travel miles, and average travel speed.

4 Experimental results

Each simulation has been run for 2 year and 6 months where the first 6 months are warm-up periods. The results are analyzed and scenarios are evaluated by measuring improvements in the KPIs introduced in section 3.3.

Figure 6 shows daily travel miles by tier for each scenario. Tier 1 represents delivery from fulfillment centers to hubs and tier 2 (last-mile) represents delivery from fulfillers or hubs to customers. Tiers 1 2 must be differentiated because tier-1 delivery can be done in the early morning when the trucks are not causing congestion issues. It can be seen with hubs, tier2 delivery miles can be further reduced even with dedicated fulfillment, and the size of reduction increases as the number of hubs increases.

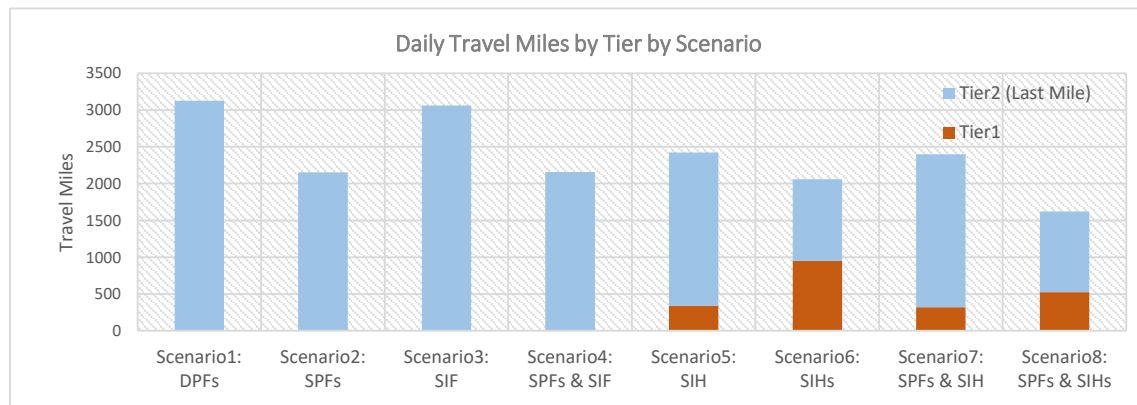

Figure 6: Daily travel miles by scenario

In Figure 7, improvements in four economic KPIs, travel miles, driving hours, fuel consumption, and labor hours, in comparison to the base scenario 1, is shown for all scenarios. The four KPIs show similar patterns: they improve significantly in all scenarios except in scenario 3. Note that the size of reduction in labor hour is the smallest in all scenarios because install and delivery time is fixed time, not affected by fulfillment nor transportation system.

Results indicate that by simply sharing openly existing fulfillment centers (FCs) and sharing last mile delivery routes, significant savings in travel miles, fuel consumption, and labor hours can be achieved. Although the savings could have been maximized due to the assumption that all FCs are located at each edge of the city, the results show that changing the organizational and operational scheme without building any new facilities can enable retailers to achieve significant fraction of the benefits of hyperconnected distribution systems. On the other hand, having openly-shared intra-city fulfillers (SIFs) hardly improves any KPI. This is because of the modeled restricted storage capacity of IFs. Similarly, there is no marginal gain on utilizing IFs in addition to openly sharing existing PFs (comparing scenario 2 and 4).

Results show that having a single shared hub (SIH) at the city center instead of SIFs improves the KPIs significantly even without openly sharing PFs. It also reduces fuel consumption a lot as smaller and more environmentally friendly vehicles can be used for last-mile delivery from the SIH as the size of each route is smaller. Increasing the number of SIHs further improves the KPIs (from scenario 5 to 6). When there exists a single SIH, openly sharing PFs does not make any difference in the KPIs (comparing scenario 5 and 7). However, when multiple SIHs exists, great marginal savings can be achieved with SPFs, as it improves tier-1 operation (comparing scenario 6 and 8). At the same time, it can be seen that marginal savings achieved by increasing

the number of SIHs is more significant when PFs are openly shared (comparing difference between scenario 5 and 6 and between scenario 7 and 8).

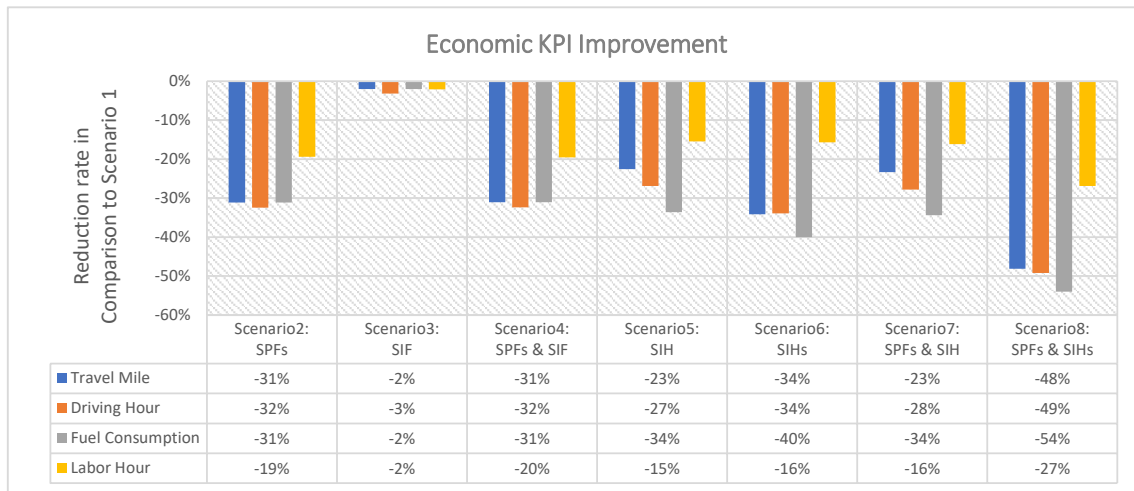

Figure 7: Economic KPI changes in comparison to scenario 1 by scenario

In Figure 8, average delays for all deliveries and average delays for delayed deliveries are shown with the reduction rate for each scenario. It can be seen that moving towards the hyperconnected scenarios can potentially increase customer satisfaction by improving punctuality of deliveries. Openly sharing FCs can improve both average delay and conditional average delay (average delay in minutes given when delay occurs). Single SIH can also reduce both KPIs. Note that the conditional delay values in scenarios 5 and 7 are similar to the values in scenarios 2 and 4 whereas scenarios 5 and 7 have significantly smaller average delay value. This means that with a SIH, the overall number of occurrence of delay decreases. With multiple SIHs, conditional average delay is also reduced.

Comparing the scenarios with single SIH to the scenarios with multiple SIHs, it can be seen that conditional average delay is reduced by increasing the number of SIHs whereas the average delay is very similar. This means that with multiple hubs, delays happen more frequently but each delay is a lot shorter. This is partly because of the routing algorithm which minimizes expected waiting time with its deliver-as-late-as-possible policy. Such a policy increases the chance of delay for the last customer and, as a result, when customers are served by a higher number of shorter routes instead of a lesser number of longer routes which increases the number of ‘last customers’, the chance of delay increases.

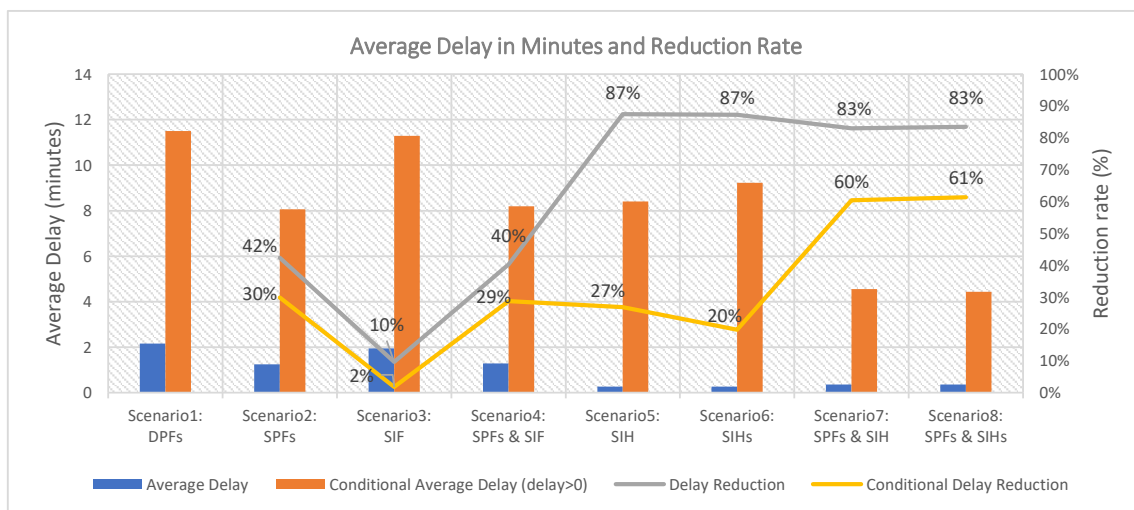

Figure 8: Average delay and conditional average delay (delay > 0) by scenario

In addition to the summary statistics, distribution of delays is shown in Figure 9 described as an average number of instances per day for a certain length of delay.

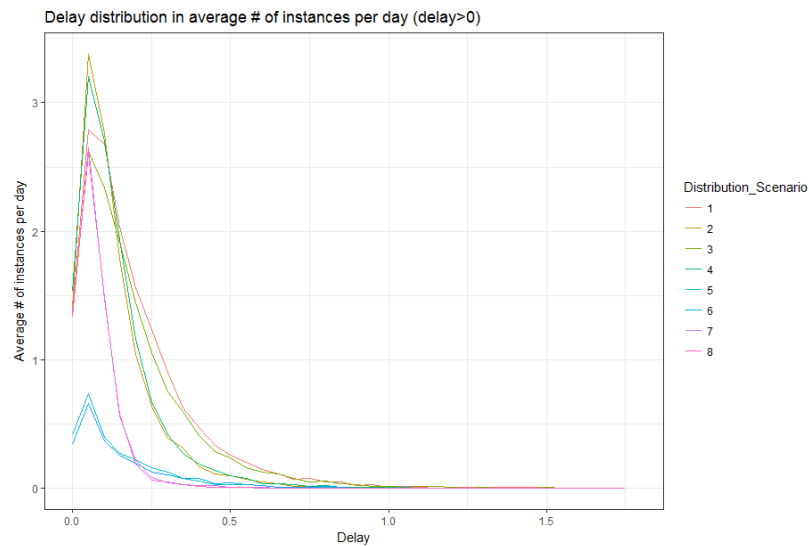

Figure 9: Delay distribution in average # of delays per day (delay > 0) by length of delay for each scenario

Lastly, the improvements in environmental KPIs are shown in Figure 10. Similar to economic KPIs, all the environmental KPIs are improved in all scenarios except scenario 3. All the other patterns and implications are consistent to those from economic KPIs.

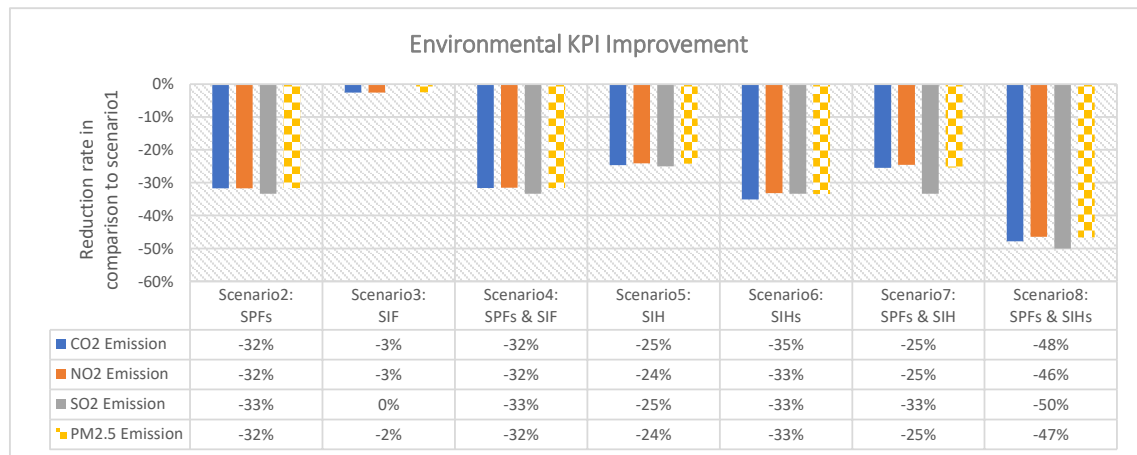

Figure 10: Environmental KPI changes in comparison to scenario 1 by scenario

5 Conclusion

In this paper, the potential of a hyperconnected logistic system for improving fulfillment and last-mile delivery of large items in urban areas is studied through simulation-based scenario analysis. Eight scenarios are carefully designed to represent various logistic systems gradually evolving from the current dedicated system to a system with hyperconnected distribution and transportation. It is shown that a hyperconnected distribution and transportation system can potentially improve significantly last-mile fulfillment and delivery. It can bring not only financial benefits but also social service capability improvement and environmental benefits. Specifically, in scenario 8, with a network of openly shared fulfillment centers (SFs) and shared intra-city hubs (SIHs), travel miles and fuel consumption are reduced by half and labor hours are reduced by about 30%. Average delay time is reduced by more than 60% where expected

delay time becomes less than 5 minutes even though a delivery is delayed. The emission of greenhouse gas, toxic gas, and fine particles from the delivery operation is also reduced by half.

Notably, it is shown that just openly sharing existing peri-urban FCs currently owned and used exclusively by each retailer can significantly improve all the KPIs. In fact, it can achieve almost half of the improvement achieved by scenario 8.

Interestingly, the operation of a shared intra-city fulfillment center (SIF) at the center of the city did not improve any of the KPIs mostly due to its limited storage capacity. This implies that smarter and more frequent inventory deployment operations would be required or additional consolidations may be required to benefit from a SIF.

On the other hand, operation of a single shared intra-city hubs (SIH) at the same location as the central SIF, at the city center, can bring significant improvement. When only a single SIH is used, openly shared fulfillment brings no marginal benefit. However, combined with a web of multiple SIHs, openly shared fulfillment creates synergy and significantly improves KPIs. Another benefit of SIHs is the use of smaller vehicles for last mile delivery. This can help ease congestion in the city during the busier daytime. Also, smaller routes resulting from the increased proximity to customers through PI hubs can potentially enable multiple deliveries a day (same-day delivery) with small marginal cost.

To conclude, this paper has investigated the potential of hyperconnected fulfillment and transportation on improving last-mile delivery of large items in a city. We fill the gap in the current literature by reporting scenario analysis based on rigorous simulation experiments. The impact and marginal benefit of different operational schemes and types of Physical Internet facilities are estimated through gradually transformed scenarios. Also, the two threads of the hyperconnected system, hyperconnected fulfillment and hyperconnected transportation, are separately studied and combined afterwards to measure the marginal impact as well as their synergy. We demonstrate that the hyperconnected system offers significant potential to improve last-mile urban operations. The results are broad enough to be used as a guide while the model city simulator we created can be used for simulating a variety of contexts through distinct city topologies, demand patterns, locations of facilities, enabling numerous hyperconnected logistics experiments beyond the one reported in this paper. Experimenting more various scenarios not only varied by changing parameters but also by further exploiting hyperconnected systems such as utilizing brick-and-mortar stores as additional fulfillment location or SIH or separating and synchronizing delivery operation and white-glove services is left for a future research.

References

Allen, J., Browne, M., Woodburn, A., & Leonardi, J. (2012). The role of urban consolidation centres in sustainable freight transport. *Transport Reviews*, 32(4), 473-490.

Bektaş, T., Crainic, T. G., & Van Woensel, T. (2017): From managing urban freight to smart city logistics networks. In *Network Design and Optimization for Smart Cities* (pp. 143-188).

BESTUFS (2007): BESTUFS Good Practice Guide on Urban Freight, http://www.bestufs.net/gp_guide.html.

Boyer, K. K., Prud'homme, A. M., & Chung, W. (2009): The last mile challenge: evaluating the effects of customer density and delivery window patterns. *Journal of business logistics*, 30(1), 185-201

Campbell, A. M., & Savelsbergh, M. (2004). Efficient insertion heuristics for vehicle routing and scheduling problems. *Transportation science*, 38(3), 369-378.

- Crainic T. G., Montreuil B. (2016): Physical Internet Enabled Interconnected City Logistics, Proceedings of 9th International Conference on City Logistics, Tenerife, Spain, Transportation Research Procedia 12, 383-398.
- Crainic, T. G., Ricciardi, N., & Storchi, G. (2004). Advanced freight transportation systems for congested urban areas. *Transportation Research Part C: Emerging Technologies*, 12(2), 119-137.
- Goyal, M., Cook, J., Montreuil, B., Kim, N., & Lafrance, C. (2016): Hyperconnected City Logistics for Furniture and Large Appliance Industry: Simulation-based Exploratory Investigation, 2016 3rd International Physical Internet Conference
- Kim, N., & Montreuil, B. (2016): Assessing the Impact of Inventory Deployment and Sharing Policies on Hyperconnected Last-Mile Furniture Logistics, 2016 3rd International Physical Internet Conference
- Montreuil B. (2011): Towards a Physical Internet: Meeting the Global Logistics Sustainability Grand Challenge, *Logistics Research*, v3, no2-3, 71-87.
- Montreuil B. (2015): The Physical Internet: A Conceptual Journey, Keynote Presentation at 2nd International Physical Internet Conference, Paris, France, 2015/07/06-08.
- Montreuil B., Meller R.D. & Ballot E. (2013): Physical Internet Foundations, in *Service Orientation in Holonic and Multi Agent Manufacturing and Robotics*, ed. T. Borangiu, A. Thomas and D. Trentesaux, Springer, p. 151-166.
- Solomon, M. M. (1987). Algorithms for the vehicle routing and scheduling problems with time window constraints. *Operations research*, 35(2), 254-265.
- Taniguchi, E., Thompson, R. G., & Yamada, T. (2014): Recent trends and innovations in modelling city logistics. *Procedia-Social and Behavioral Sciences*, 125, 4-14.
- Van Duin, J.H.R., H. Quak, and J. Muñuzuri (2010): New challenges for urban consolidation centres: A case study in The Hague, *Procedia-Social and Behavioral Sciences*, 2(3), pp.6177-6188.
- Xing, Y. F., Xu, Y. H., Shi, M. H., & Lian, Y. X. (2016). The impact of PM2. 5 on the human respiratory system. *Journal of thoracic disease*, 8(1), E69.

Simulation-based optimization approach for PI networks

Christian Haider¹, Alexander Kinast², Stefanie Kritzinger², Erik Pitzer¹, Michael Affenzeller¹

1. Heuristic and Evolutionary Algorithms Laboratory,

University of Applied Science Upper Austria, Campus Hagenberg, Austria

2. RISC Software GmbH, Hagenberg, Austria

Corresponding author: christian.haider@fh-hagenberg.at

Abstract: *The Physical Internet (PI) aims to connect single logistic networks to develop an open and global transportation network for shipping physical goods from its starting point to its destination. This creates big challenges: through the openness and size of the network, multiple objectives and many restrictions have to be considered. This paper proposes a new simulation-based optimization method for modeling and optimizing these problems. It is shown how the optimization is used to evaluate solution candidates for the problem and how the simulation is used to evaluate the quality of the candidates.*

Keywords: *Physical internet, genetic algorithm, fast forward simulation, simulation-based optimization, logistics network, HeuristicLab*

1 Introduction and problem description

Within a PI network, the principles of the Internet are applied to logistics. A global, open, network of networks, using a set of collaborative protocols and standardized smart interfaces, in order to send and receive physical goods contained in standard modules – instead of packets of information, as does the Internet (Montreuil et al. (2013)). This paper is focusing on the implementation of the optimization and simulation algorithm of the PI network.

The optimization algorithms are realized using HeuristicLab (<https://dev.heuristiclab.com>¹), a framework for heuristic and evolutionary algorithms (Affenzeller et al., 2015; Wagner et al., 2014). Since HeuristicLab offers a great variety of genetic algorithms that can be applied to different problem representations (e.g. vehicle routing problem (Toth and Vigo, 2014)), we developed a new definition for the Atropine-PI network problem. The simulation program easy2sim (<http://www.easy2sim.at>²) maps easily logistic processes, which makes planning, evaluation and optimization possible. We modeled and implemented a simulation library of PI components to evaluate solution candidates created through the optimization.

Within this paper we apply the presented algorithms on real world data. This data is provided by the industry partners of the Atropine project. The Atropine (Fast Track to the Physical Internet) project, is a project which tries to model a test region for the PI in Upper Austria and Southern Germany (Brandtner et al. (2017)). The industry partners contain 4 shippers and 2 logistics service provider. The results in this paper show the data set from the year 2016 of this companies, in the further section of this paper the “Atropine-PI network” is based on the combined hub infrastructure of the single logistic service providers and the shipments are based on the provided information of the 4 shippers. Another restriction in the given data set is, that the shipments only contains dry material orders, no sales or refrigerated goods. These

¹ Last visit: June 6th, 2018

² Last visit: June 6th, 2018

restrictions were made, because the whole process was tested in a real-time scenario during a test-phase of the project.

2 Solution method: Simulation-based optimization

Within the defined problem definition of the Atropine-PI network, a new data encoding for the representation of this problem was developed (see *Figure 1*). Furthermore, we show different mutation methods, which work on the data encoding and are derived from the standard genetic algorithm (GA) manipulation methods of HeuristicLab. Because the newly developed methods are based on standard implementations of HeuristicLab, it is possible to use different population-based GA implementations (e.g. standard GA, OSGA, ES) from the HeuristicLab framework.

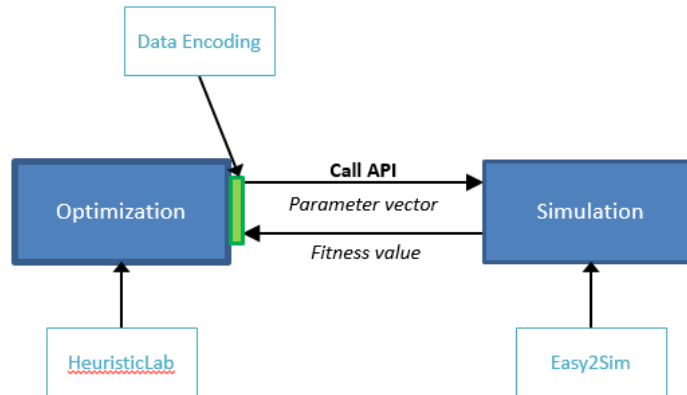

Figure 1: Communication between Optimization and Simulation (Haider et al. (2017))

2.1 Data encoding

In order to handle all the needs of the Atropine-PI network, a new data encoding for the problem representation was developed. The encoding represents the route that an order takes through the Atropine-PI network. Therefore, a vector with a random size will be generated. The size of the vector indicates the amount of hubs which the shipment pass (e.g. the vector in *Figure 2* has a length of 7, that means that the order has to pass 6 hubs). All of this vectors follow the same pattern:

- **Position 0:** Holds the ID of each order. This is important to identify each order at each time and it is necessary for the simulation part, to get the significant information about each order e.g. type of truck, service time, cost rates, ...
- **Position 1:** Holds the starting hub of each order. This position is fixed and can't be changed during mutation or crossover.
- **Position 2-(n-1):** Every order can have multiple sub-hubs which has to be visited through the traveling process. It is also possible that special flags are set e.g. -1 that indicates that the order has to be transported directly to the goal-hub without visiting anymore sub-hubs. It is also possible to define any other special cases, therefore just a flag has to be implemented.
- **Position n:** The last position in the vector holds the destination hub. Like the starting hub, the destination hub is also fixed and can't be changed during mutation or recombination phase.

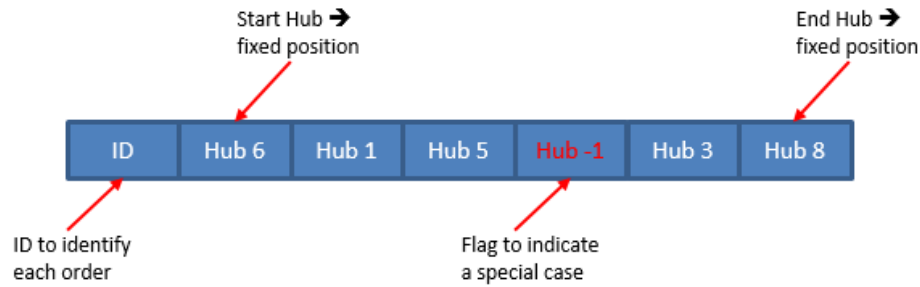

Figure 2: Illustration of the data encoding

2.2 Data structure

Since the simulation and optimization part are independent from each other and use their own frameworks, a common data structure for passing the information between these two parts is defined. The defined data structure is visualized in *Figure 2*. The structure is based on a vector with size n , which is equal to the problem size and the number of orders in the PI network. Within the vector, there are orders with the previously described encoding (see Section *Data encoding*). This data structure is used to hold all necessary information about the arrangement of the orders in the network and will be passed through the API of the applications (see *Figure 3*).

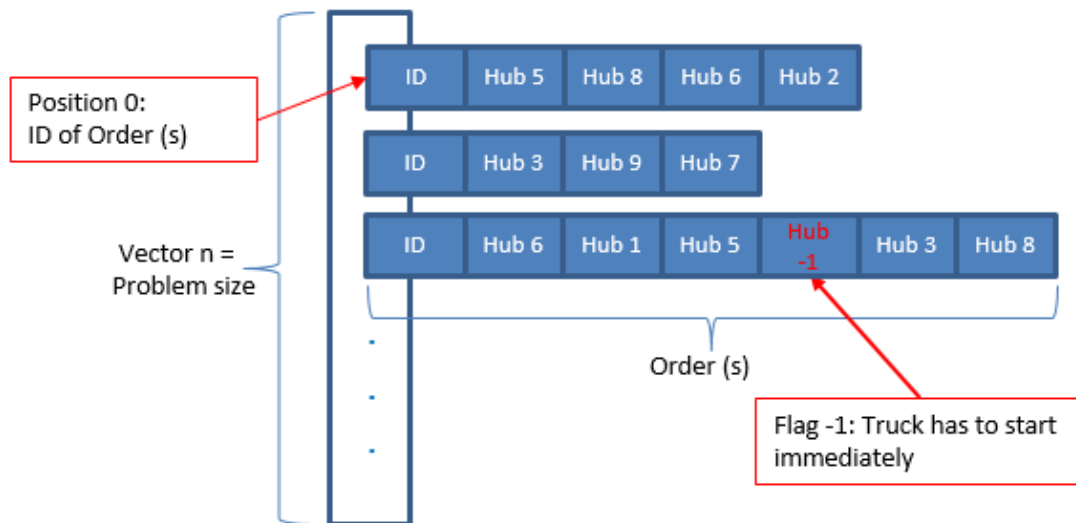

Figure 3: Illustration of the data structure

2.3 Crossover

The goal of the crossover function in a GA is to produce “good” offspring from two selected parents of the population. Therefore, different parts of the gene representation of both parents are used to create a new offspring (Poon and Carter, 1995). To create the offspring vector from the parents, the sequences of the parents are cut into parts. To get the necessary cut points, different methods can be used e.g. single-point, two-point or n -point crossover. In *Figure 4* the binary mask crossover, which is used as crossover in the Atropine-PI network, is presented. The binary mask crossover is an expression of the n -point crossover. The n -point crossover defines n cut points where the parents’ sequences are cut. For the binary mask crossover, two “fit” parents are selected and a binary mask is applied to the two parents. After applying the mask over the parents, the new solution is created by taking the order either from parent one or from parent two, depending on the mask. This mask is initialized randomly at the beginning of

the algorithm. During the iterations the mask changes by making the sequences of parent 1 and 2 longer. That means that in the start of the algorithm more cut points will be used to get a better mixing of the two parents. The longer the algorithm runs the longer the sequences of genes from parent 1 or 2 will be. The reason why this happens is, that with more iterations the parents will get better and better and the recombination should not destroy good sequence of the parents.

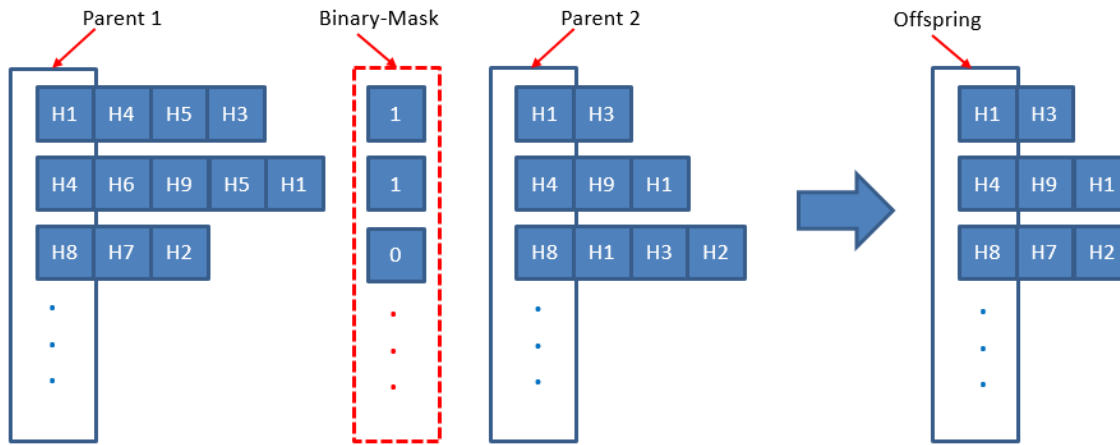

Figure 4: Demonstration of the binary-mask crossover

2.4 Mutation

One of the steps during the genetic algorithm workflow is mutation, which helps to maintain diversity in the population of solution candidates. This is especially important to avoid premature convergence and to be able to continue exploring the search space (Mitchel, 1995; Alba and Troya, 1999).

The most basic examples of mutation operators are defined on chromosomes, which are represented as bit strings. For this special representation of the solution vector, some bits of these string are randomly selected and exchanged with their complement, this method is called bit-flip (Lin et al., 2003) (see Figure 5).

Bit-String orig. 110001011001
 ↓ ↓
 Bit-String mut. 110101010001

Figure 5: Representation of a classic bit-flip mutation

This paper proposes a new encoding to facilitate the optimization within the Atropine-PI networks. With the new data encoding, new mutation methods were introduced. For the special needs of the Atropine-PI network, the following mutation methods were developed:

- **Swap-Stop-Mutator in Figure 6a)** this mutation method randomly selects a hub in the encoding and replaces it with another hub available from the hub-list.
- **Swap-Sequence-Mutator in Figure 7b)** this method randomly replaces a sequence of hubs with another randomly selected sequence
- **Add-Hub-Mutator in Figure 6c)** this method adds a hub to the solution vector, that leads to a growth of the vector length

- **Add-Sequence-Mutator in Figure 6d)** randomly adds a sequence of hubs to the solution candidate
- **Delete-Hub-Mutator in Figure 6e)** randomly deletes a hub from the solution vector
- **Delete-Sequence-Mutator in Figure 6f)** randomly deletes a sequence of hubs from the vector

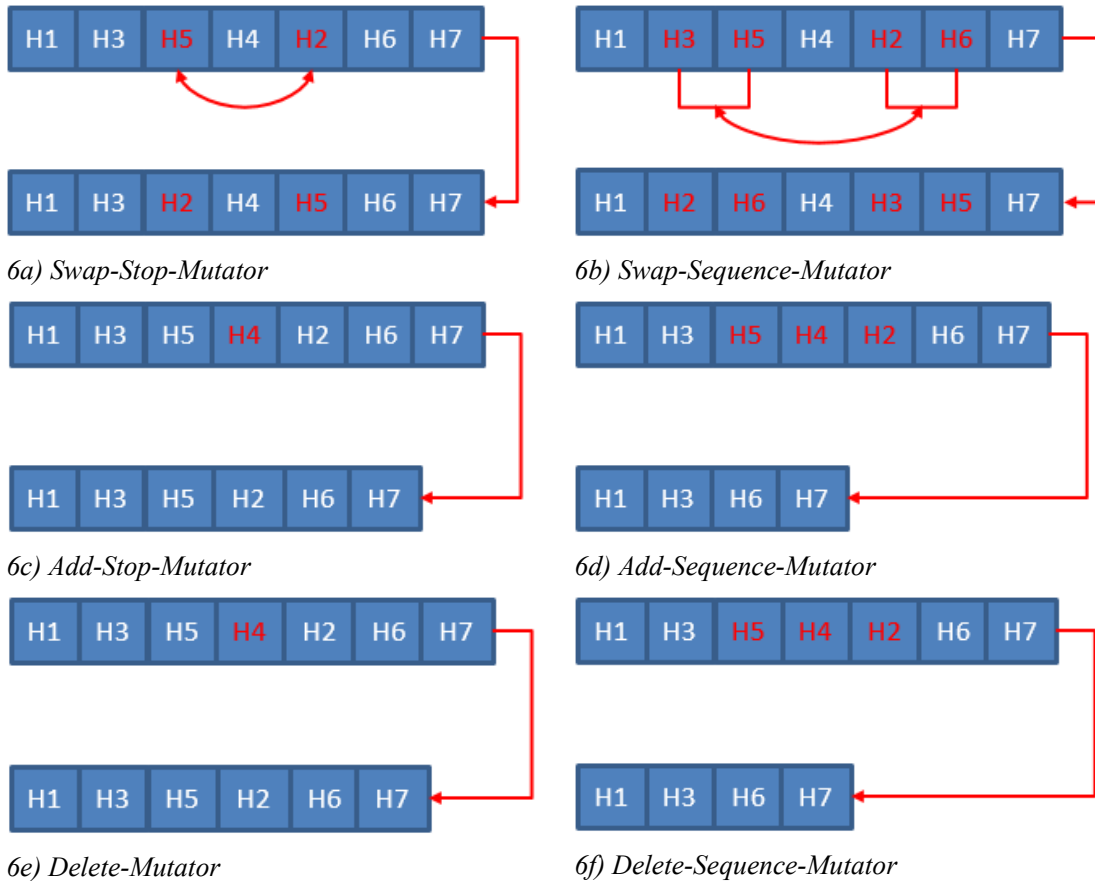

Figure 6: Mutation methods

2.5 Simulation

Since a simulation-based genetic algorithm (Figure 1) evaluates many solution candidates to achieve reasonable results, the evaluation of a single solution candidate has to be calculated in reasonable time. An efficient way of reducing the evaluation time is the combination of steps through pre-processing. Pre-processing steps are, for example, the validation of the input data, or loading the simulation file into random access memory. In a standard simulation, every cargo item and every truck is simulated in every simulation step; this yields in a more intelligent but slower evaluation. The developed fast-forward method differs in the following way: Each cargo item is considered through its whole route from the start to the end. Trucks are created, when they are needed, to deliver a cargo item in time. This means that trucks will get inserted based on the order of the cargo input.

The simulation file contains detailed information of the simulation: number of existing hubs and links within the considered Atropine-PI network. All this links and hubs are parameterized. Some sample parameters are latitude, longitude, zip code as well as information of the owner

(e. g. a company) of a hub. Additionally, cost specific parameters can be set in this file, for example, storage cost in a hub or the truck base cost value that is used to calculate the cost of a truck. Also, the cargo list is part of the simulation file. Each cargo has certain information that is necessary for the calculation.

2.5.1 Fast-forward method

The fast-forward method differs to the standard simulation, since the route of one cargo is calculated from the start to the end. For every cargo in the solution vector, the following decisions are defined:

- When the cargo arrives in a hub, existing trucks are checked. If a truck with free space exists and the truck reaches the destination in time, the cargo is loaded on the existing truck. If no truck exists, a new truck is created. If this truck has to drive on a new route that is not defined in the simulation file or has not been used before, a penalty will be added. Default parameters will be set for this truck. If more cargo exists after loading this cargo on the truck, the check for available trucks is done again. Based on the order of the input, slightly different simulation results can be reached.
- If a cargo leaves a hub, storage cost is added based on the departure of the truck. When all cargo has been transported to the next hub, the next step in the solution vector has to be checked. If the cargo has reached its destination, the next cargo can be considered. If no more cargo is left, the total cost can be calculated.

Figure 7 describes the process model of a simulation evaluation.

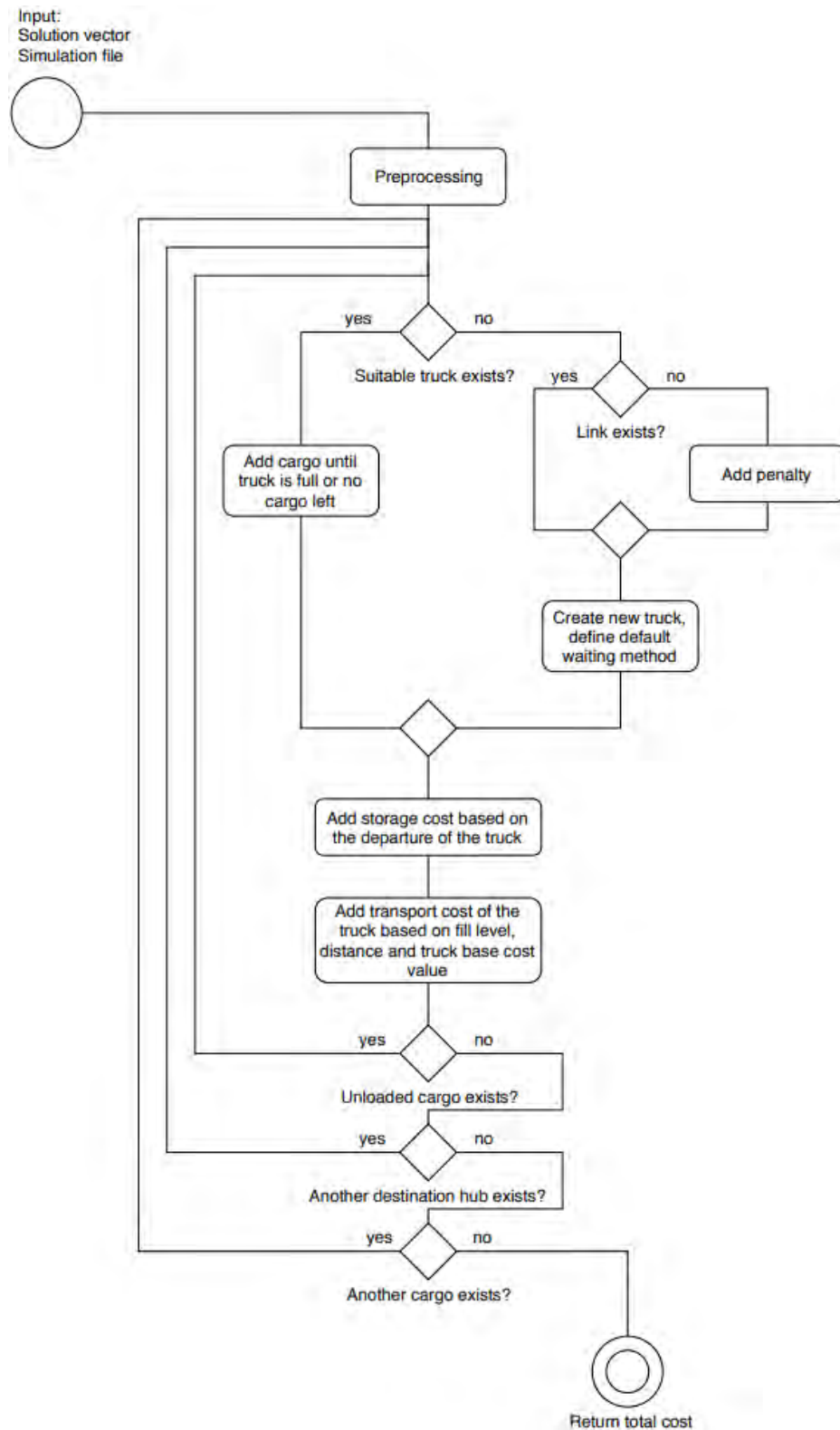

Figure 7: Process model of the fast-forward evaluation method

The advantage of the fast-forward method is that the truck costs are added after every cargo has been transported. This means, the truck price is calculated based on the real loaded cargo. This price can be split between all palettes. Adding the costs for storage, handling, transport and

penalty (if necessary) results in considering the whole solution vector for calculating the total costs.

2.6 Optimization Algorithm

This section shows the basic idea behind the genetic algorithm. In *Figure 8* the main steps of the algorithm are shown.



Figure 8: Genetic Algorithm Steps

Steps of the algorithm:

1. At the initialization of the algorithm all information needed will be provided. That includes the Atropine-PI network with all the hubs which are available in the network, the list of orders which contains all necessary information about the orders for the simulation and optimization and some parameters for the optimization algorithm, which will be explained in the following steps. Also the first solution candidates will be created at this steps. Based on the number of population size, candidates with the presented data structure (*section 2.2 Data structure*) are created.
2. After the first solution candidates are created the first evaluation follows. Because the method described here is a simulation-based algorithm, this step is done by the simulation part. Therefore, the optimization calls and sends the data to the simulation (see *Figure 1*). The simulation takes the provided data from the optimization and calculates the fitness for each solution candidate. The calculation is done by using a cost function with some important parameters. The parameters are cargo handling costs, costs per kilometer for cargos, storage costs, fill level of trucks and truck loading capacities.
3. After the solution candidates from the initialization step are calculated the result is send back to the optimization part (see *Figure 1*). After receiving the fitness for each solution candidate, the algorithm selects the parents which are taken into account for creating the new solution candidates. The way how the parents are selected can be chosen by parameter (e.g. roulette wheel selection, tournament selector, best selector, ...)

4. The next step is the variation. At this point the recombination (see *section 2.3 Crossover*) of the selected parents from step 3 takes part. The type of the recombination can also be chosen by parameter. The second part of the variation process is the mutation. Since the mutation won't be applied to all solution candidates a parameter called mutation rate/probability is set. The second mutation parameter is the mutator type (for the different mutators see *section 2.4 Mutation*).
5. Next step is the fitness evaluation of the newly created solution candidates. At this point the optimization algorithm calls again the simulation part like it happened at step 2 of the algorithm.
6. Next step is the selection of the survivors. Therefore, the fittest candidates were chosen to stay in the population.
7. After that, the algorithm does several iterations for step 3-6. The amount of iterations can be set through a parameter. With the maximum generations parameter, a hard cap of iterations can be set.
8. In the end after all iterations are done, the result vector will be returned.

3 Results

This contribution shows some test cases that were defined through the input of transport service providers and shippers. These test data are based on real-world data and it is shown how the use of an open and global logistic network optimized by a simulation-based algorithm can lower the overall costs.

In this test scenario 4 shippers and 2 logistics service providers with a total volume of 568 165 pallets are used. In *Figure 9* the distribution of the transported pallets is visualized.



Figure 9: Distribution of goods

For the test runs presented in this paper the following parameter settings were used:

- Atropine-PI transportation network
 - Hubs are real world hubs from the given logistics service providers and shippers
 - The first- and last mile of the orders are calculated by the beeline to the starting hub
 - Single → The different logistics service providers and shippers are separately routed through the Atropine-PI network (state-of-the-art without bundling between the different partners)
 - Together → The different logistics service providers and shipper are routed together through the network (PI strategy with bundling between the different players)

- Cost function parameter settings
 - Cargo handling charges: 1.5€/pal
 - Costs per kilometer: 1.05€ plus extra charges for short distances
 - Storage costs: 0.2€/pal
 - Filling degree: Based on 3 steps (empty, half-full, full)
 - Truck loading capacity (pallets): 32 pallets
 - Truck loading capacity (tons): 24t
- Optimization algorithm parameter settings
 - Algorithm: Offspring Selection Genetic Algorithm (OSGA)
 - Crossover: Binary mask crossover
 - Elites: 1
 - It's the number of elite solutions which are kept in each generation of the run. It is kept low, because it should not be too greedy.
 - Maximum Generations: 600
 - It ensures that the algorithm stops at least after 600 generations. This was chosen due to tests, which showed that after 500 generations there wasn't any progress anymore.
 - Maximum selection pressure: 800
 - The maximum selection pressure which terminates the algorithm. After several test runs it shows that after 800 selection pressure the algorithm already reached its optimum. It's the primal termination point of the algorithm. Normally the selection pressure hits before the maximum generations are hit.
 - Mutation probability: 12%
 - In our test run we use a fairly high mutation probability, because the algorithm is highly mutation driven.
 - Mutator
 - As mutator all 6 mutators shown in the previous section Mutations are used.
 - Therefore, one of the mutators is selected randomly based on the success progress.
 - Population size: 300
 - The size of the population of the solution.
 - Selected Parents: 600
 - How many parents are selected at each offspring step until the population is filled. This parameter should be the same or double the size of population size, for smaller problems and smaller for bigger problems.
 - Selector: Proportional selector / roulette wheel selector
 - Selects the solution for the reproduction process (crossover)
 - The proportional selector ensures that better solution will be taken with a higher percentage but it also allows worse solution to be taken.

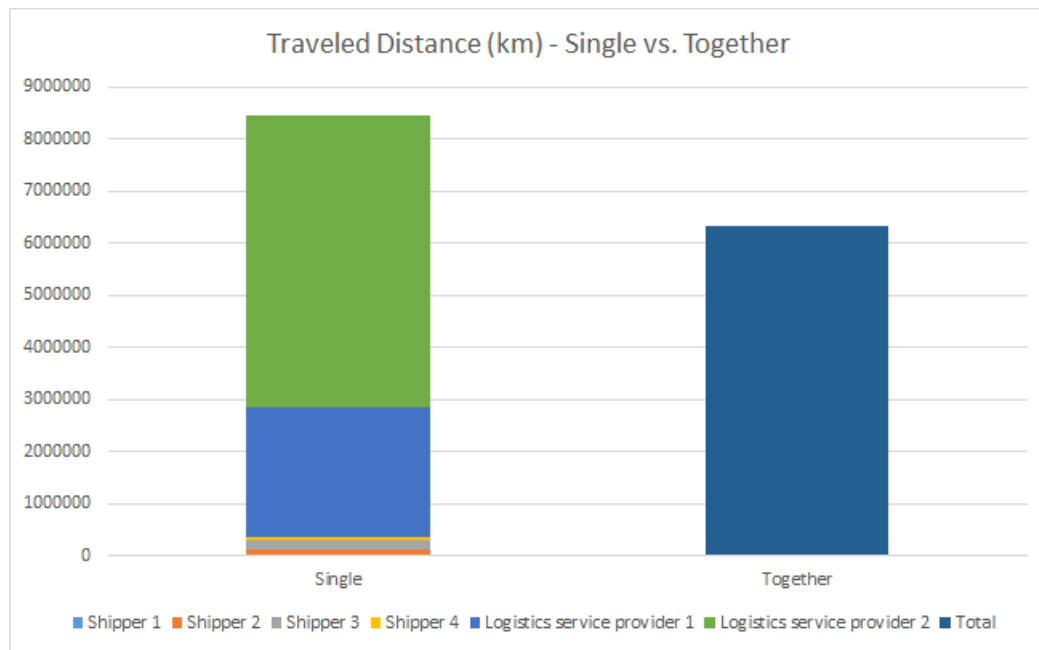

Figure 10: Total distance traveled – compared between single partners and within the open Atropine-PI network

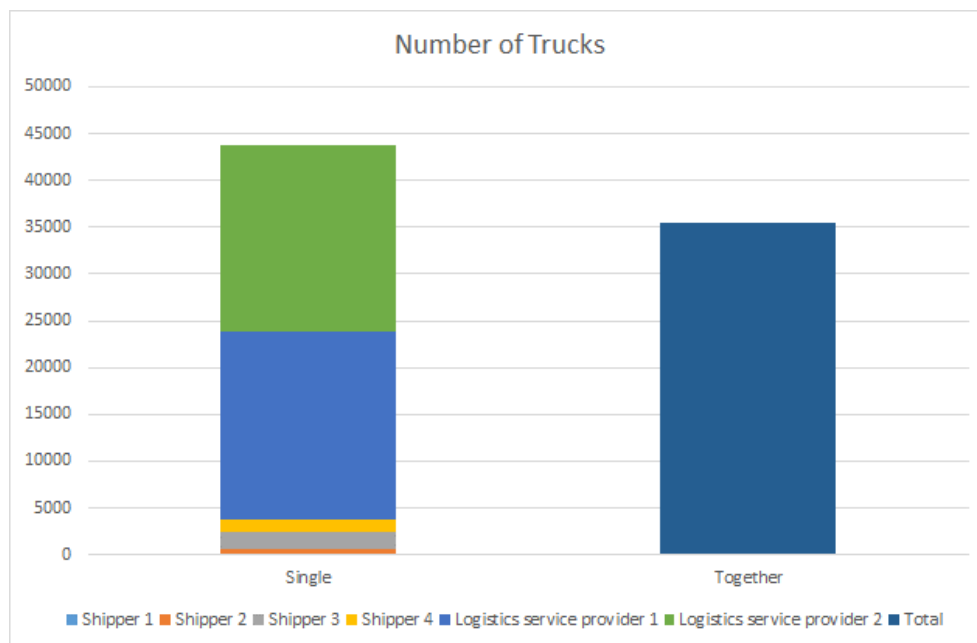

Figure 11: Number of trucks used – compared between single partners and within the open Atropine-PI network

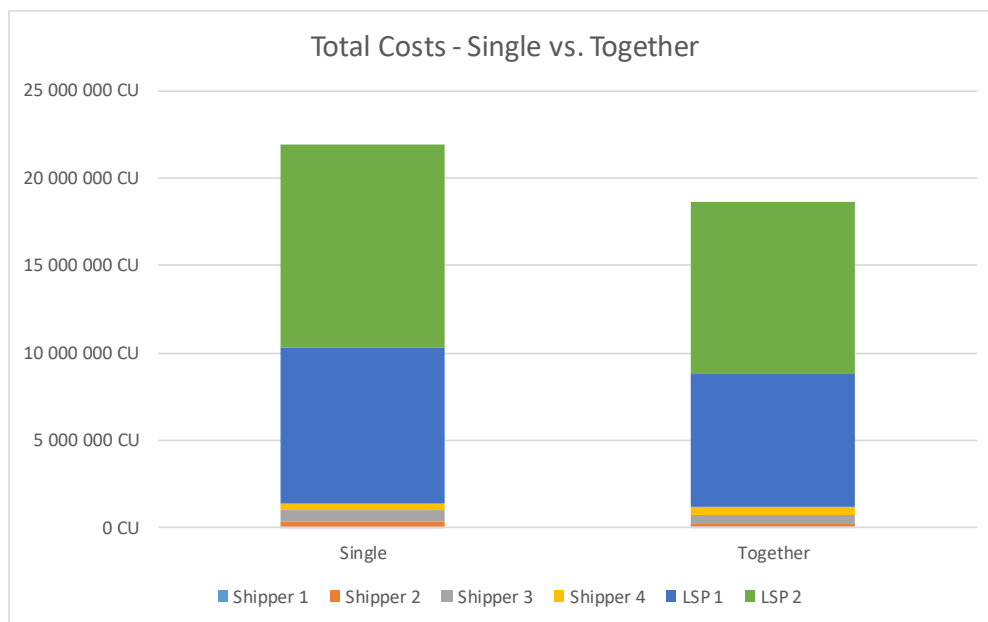

Figure 12: Total Costs in CU (cost units) – compared between single partners and within the open Atropine-PI network

As Figure 10, Figure 11 and Figure 12 show, routing within the open and global Atropine-PI network can lead to a reduction of resources and traveled distance. On the left side, the calculation is done for every single partner separately (this is the state-of-the-art concept without bundling between the different partners in the network); on the right side all orders of all partners are routed through the globally opened transportation network (PI strategy with bundling between the different partners). All these calculations were done with the new optimization and simulation methods.

4 Summary and Outlook

In this paper, we described the implementation of a simulation-based optimization algorithm solving of an Atropine-PI network. In the result section a test run of the algorithm with real world data from logistics service providers and shippers is shown. It is shown that PI can lead to a sufficient reduction of traveled distance and number of trucks, if the volume is big enough. In a second test run the volume was reduced by the orders of the logistics service providers and the impact of the PI was reduced dramatically. That leads to the result that, only a sufficient volume of physical goods is necessary to develop the potential of the PI thought.

Due to the fact, that the purpose of the paper is to model a “PI model region”, the given data set is comparatively small and not totally representative for the real PI concept, it is shown that with the presented algorithms a bundling effect between different players in the logistics world is possible and profitable.

The idea behind the algorithm and the model region is, that the “whole PI network” can be seen as network of networks, that makes the algorithm also scalable for larger networks.

Acknowledgements

This work has been funded by the program ‘Innovative Upper Austria 2020’.

References

- Affenzeller, M., Beham, A., Vonolfen, S., Pitzer, E., Winkler, S.M., Hutterer, S., Kommenda, M., Kofler, M., Kronberger, G. and Wagner, S., 2015. Simulation-Based Optimization with HeuristicLab: Practical Guidelines and Real-World Applications. In *Applied Simulation and Optimization* (pp. 3-38). Springer International Publishing.
- Alba, E. and Troya, J.M., 1999. A survey of parallel distributed genetic algorithms. *Complexity*, 4(4), pp.31-52.
- Brandtner P., Simmer L., Plasch M., Haller A., Kalt M., Neubauer M. - Atropine – Fast Track to the Physical Internet - Proceedings of the 4th International Physical Internet Conference (IPIC 2017), Graz, Österreich, 2017
- Haider C., Pitzer E., Affenzeller M. - Simulation-Based Optimization in the Field of Physical Internet - Proceedings of the 4th International Physical Internet Conference (IPIC 2017), Graz, Österreich, 2017, pp. 6
- Lin, W.Y., Lee, W.Y. and Hong, T.P., 2003. Adapting crossover and mutation rates in genetic algorithms. *J. Inf. Sci. Eng.*, 19(5), pp.889-903.
- Mitchel, M., 1995. Genetic algorithms: An overview. *Complexity*, 1(1), pp. 31-39.
- Montreuil B., Meller R. D., Ballot E., 2013. Physical Internet Foundations. In "Service Orientation in Holonic and Multi Agent Manufacturing and Robotics" (pp. 151-166), Eds. Borangiu T., Thomas A., Trentesaux D. Springer Berlin Heidelberg.
- Poon, P.W. and Carter, J.N., 1995. Genetic algorithm crossover operators for ordering applications. *Computers & Operations Research*, 22(1), pp.135-147.
- Toth, P. and Vigo, D. eds., 2014. *Vehicle routing: problems, methods, and applications*. Society for Industrial and Applied Mathematics.
- Wagner S., Kronberger G. K., Beham A., Kommenda M., Scheibenpflug A., Pitzer E., Vonolfen S., Kofler M., Winkler S. M., Dorfer V., Affenzeller M., 2014. Architecture and Design of the HeuristicLab Optimization Environment. *Advanced Methods and Applications in Computational Intelligence (Contributions to Book: Part/Chapter/Section 10)*, (Editors: R. Klempons, J. Nikodem, W. Jacak, Z. Chaczko) - Springer, pp. 197-261.



Arriving on time using uncertainty aware deep learning

F. Hillerström¹, M. Kruithof¹ and S. Oggero¹

1. Intelligent Imaging, TNO Netherlands Organisation for Applied Scientific Research,
The Hague, The Netherlands

Corresponding authors: fieke.hillerstrom@tno.nl; maarten.kruithof@tno.nl; serena.oggero@tno.nl

Abstract: *The Port of Rotterdam is an important hub in international maritime supply chains. Efficient functioning of the port requires accurate planning of the processes, thus reducing waiting times and costs for all parties. Therefore, predictions should be incorporated in the planning of all logistic processes. In particular, uncertainty information is fundamental to estimate the reliability of predictions and to adjust the planning. It is estimated that only the direct benefits of optimizing a port call can add up to \$80,000 and CO2 can be reduced up to 240 ton per port call (MaritiemNieuws, 2017).*

In this research we combine the domain knowledge about logistics with data driven approaches to obtain an uncertainty aware Estimated Time of Arrival (ETA) prediction for incoming vessels by using deep learning.

Our proposed network provides better ETA predictions than the estimations currently in use, and provides an uncertainty estimation on the prediction. Our experiments show that the uncertainty cannot be reduced by adding more training data of the same type as the one available. Finally, our experiments show the importance of domain knowledge combined with data-driven techniques, to understand the behavior of the network; the lowest uncertainty is anyway obtained by combining all available parameters.

Keywords: *Uncertainty, Deep learning, Predictive analytics, Data driven logistics, Predictive arrival time*

1 Introduction

The Port of Rotterdam is an important hub in international maritime supply chains. Accurately predicted estimated times of arrival (ETA) allow the removal of the unnecessarily built-in slack in the form of large supplies and long delivery times. Boating, piloting, mooring, unloading, stacking, loading for inland shipping, unloading at inland terminal, stacking, loading on truck and unloading at the receiving location is in principle possible without any noticeable waiting times between the process steps. The value of optimizing the supply chain using predicted ETAs becomes evident since a container transported from Singapore to Duisburg is standing still 400 of the 900 hours, for example.

Obtaining an accurate ETA of incoming ships is critical for planning across logistic chains that involve international vessel connection. Since the travelling time of vessels not only depends on speed and distance, but is also subject to external influences such as weather, human behavior and stock prices, the prediction of the arrival time of vessels is not trivial.

Adding an indication of the uncertainties of these ETA predictions gives users the opportunity to link a risk estimation to the planning. When this risk is known for all the logistic processes involved in shipping, the overall risk can be minimized. This would lower costs and increases planning efficiency.

Non-physical parameters that influence arrival times, such as human choices, make it difficult to use only a physics-based model. Therefore, we use a neural network for ETA prediction,

because of its ability to learn complex relations between inputs, without necessarily having to explicit relations between all available parameters. In particular, the availability of large datasets allows for the use of *deep* neural networks, which increases the chance of high performance. To add uncertainties to the neural network, we use concrete dropout as shown by Gal et al. (2017). We compare our network predictions with the arrival time predictions of the ship agents¹ and with a simple physical model based on distance and speed, hereafter referred to as “naïve model”. We analyze the influence of the amount of data, the choice of input parameters and the value of domain knowledge on the errors and uncertainties of the network.

In Section 2 we present a theoretical background to predicting time of arrivals with different models and we discuss the choice of a deep neural network. In Section 3 we introduce methods to add an uncertainty estimation and we discuss the choice of the concrete dropout method; in Section 4 we present our results and show a number of additional experiments to analyze the performance and behavior of our uncertainty aware ETA predictions. Finally, in Section 5 we summarize our conclusions and give recommendations for future research.

2 Background

2.1 Methods to predict ETAs

A classic approach to predict time of arrivals of (container) vessels implies building a physical model that relies on the followed route. Since the route itself is often not communicated to the port, route identification prediction is often part of the modelling (Meijer, 2017). Typically, the current location of a vessel is used to predict the possible routes through different statistical models, for example using waypoints estimation (Pallotta et al., 2013), Bayesian networks (Nevell, 2009) (Salleh et al., 2017), or Hidden Markov Models (e.g., used to model port-visitation patterns, (Lane et al., 2010).

Other methods rely on machine learning techniques trained on historical data, such as Support Vector Machines (Parolas, 2016) and neural networks (Fancello et al., 2011). In Meijer (2017) route identification approaches are combined with machine learning. These studies show that neural networks have the potential to provide more accurate predictions regarding the ETA of a container vessel. With a sufficiently large training set available, deep neural networks could therefore provide a promising approach to more accurate predictions, although, to our knowledge, no study has been done yet specifically applying deep networks.

2.2 Methods to add uncertainty to deep learning predictions

A well-known way to extract uncertainties from deep learning models is the usage of Bayesian neural networks (Freitas, 2003), where distributions are placed over the weights to calculate an output distribution. These networks come with additional computational costs and are therefore less applicable to more complicated models. Recent work has shown that Bayesian networks can be approximated using dropout, which comes with less computational costs (Gal & Ghahramani, 2016). Using Concrete dropout (Gal et al., 2017) it is even possible to automatically tune the dropout rate and extract two different types of uncertainties; aleatoric and epistemic uncertainties² (Kendall & Gal, 2017). The final output of the model will be an

¹ the ETA is guessed by the crew of a vessel (Gómez et al., 2015).

² Aleatoric uncertainty captures the noise on measurements on a single data point. It is the uncertainty with respect to information which our data cannot explain. Therefore this type of uncertainty cannot be reduced by adding more samples of the same data type. Epistemic uncertainty is the uncertainty in the model, uncertainty in terms of answers to question as ‘What model to use?’ and ‘Which model generated our collected data?’. This uncertainty is due to the dataset as a whole and can be reduced by adding more samples of the same type to the training set. Distinguishing these two types of uncertainties gives more insight in the working of a model and helps to answer different questions. The question whether we can guarantee a maximum level of uncertainty by choosing the right type and amount of training data, can be answered by looking at the two uncertainties together.

estimated ETA and the standard deviation of the ETA. Assuming a normal distribution of the result we can calculate the chance of a ship arriving within a certain time interval.

3 Methodology

3.1 Model and network properties

We propose the usage of an uncertainty aware neural network for the ETA prediction of vessels. To add model uncertainty to the network we implement a network that uses concrete dropout similar to the networks used by Gal et al. (2017).

Using expertise knowledge about the vessel logistics domain, we select which input parameters to use. This expertise knowledge is important not only to select the valuable parameters, but also to be able to explain the behavior of the network, for example by helping to interpret the sensitivity to the network to specific parameters or by selecting specific parameters instead of just adding all available ones (see also Section 4.4). We believe that both domain expertise and a data-driven approach are needed to develop a reliable network.

The chosen input parameters are: information about the ship itself (length, width, ship type, vessel identification number or IMO), the current state of the ship (speed), information about the current location of the ship (latitude, longitude, distance to go) and about the sea conditions at that location (current speed). The dataset also contains a prediction of the arrival time made by the ship agent (ship agent ETA), which is sparsely updated.

The used network contains three hidden layers of 32 nodes each and predicts the mean (μ) and standard deviation (σ) of a normal distribution for the time of arrival of the vessel. The network is trained using stochastic gradient descent.

3.2 Training Data

The data used in the experiments is data collected from real vessel trips. Each trip contains a number of data points in time with the inputs parameters as listed above. There are multiple trips for one vessel in the dataset. Part of the parameters is obtained from the Automatic Information System data (AIS), collected via AIS hub³. The other parameters are provided by a vessel company; see also Table 1 for more information on the used parameters.

We analyze the performance and behavior of our uncertainty aware ETA predictions in several experiments. Our experiments are run on two different datasets with vessels travelling from the Mediterranean Sea to the port of Rotterdam. One dataset contains information and data about container ships, the other about tanker ships. The type of ship has influence on the predictability of their arrival time, because of the different type of freight a ship contains.

All the experiments are done for these two different datasets. The data is split into training, validation and test set, (random sampling), using the vessel's unique IMO number to prevent overlap between train and test set. The original dataset contains a lot of samples, per vessel and per vessel's unique trip. In order to prevent overfitting on a specific trip, we select a data point from each unique trip every 30 minutes. The actual time of arrival (ATA) is calculated (per data point in time) by taking the difference between the time of that data point and the time of the last data point of the corresponding trip. The data input parameters are normalized to have a mean of one, before being fed to the neural network.

On the base of interviews with logistics domain experts, we identify unrealistic samples and remove these outliers from the dataset. This includes: samples with a speed larger than 20 knots

³ The Automatic Information System, also known as AIS, has been introduced by the International Maritime Organization in 2000. Every vessel that conducts international voyages with a tonnage of 300 and upwards or vessels with a tonnage above 500 are obliged to have AIS installed since 2005. AIS hence became the standard in real-time vessel to vessel and vessel to shore Communications (Meijer, 2017).

(the accepted speed limit for ships on the considered routes), a ship agent ETA larger than 25 days (considered a general maximum duration on the considered routes) or lower than -2 days (often the case if the ship agent does not update the ETA during the trip after a first estimate), and a distance from the standard route larger than 200 miles (such a large deviation is already indicating a change of destination) .

3.3 Experiments

The first experiment compares the prediction accuracy of a deep neural network based prediction with uncertainties to current not deep learning bases ETA estimators. The goal is to validate that our method adds valuable information on the uncertainty on the prediction, while still maintaining a high performance on the predictive power; see also Figure 1.

To check our assumption about the normal distribution of the actual times of arrival ATAs, we perform a second experiment. First we produce, per data point and predicted ETA, a predicted ETA distribution; this is obtained under the hypothesis that the time of arrival predicted by the neural network is the mean of a normal distribution and that the uncertainty predicted is its standard deviation. Once the ETA distributions are obtained for all predictions, they are normalized to have a mean of zero and a standard deviation of one. Thereafter we plot the corresponding ATA for that trip (data point) in the ETA normalized distribution; the relative location of the ATA in the ETA distribution indicates how much distance, in standard deviations, is there between the predicted ETA and the ATA. Afterwards, the relative locations of all ATAs for all data points form a so-called “ATA distribution”, whose shape allows to test the assumption of a normal distribution; see also Figure 2.

The importance of different input parameters is evaluated by training and evaluating networks trained on a subset of all the available parameters. With these experiments we want to show the importance of expert knowledge in data selection. Our domain experts ranked the available input parameters on importance for the ETA prediction (see Table 1). Step-by-step we add extra parameters to the experiments, based on their ranking. We show the influence of the selected data on the prediction accuracy and uncertainties; see also Figure 3.

We increase the number of parameters in two ways; in one approach, we start with the most valuable parameter and add the less valuable parameters, in the other approach we start with the least valuable parameters. The experiments are repeated multiple times and the uncertainties of all predictions are averaged.

Table 1: Input parameters ordered by importance by the domain experts. The column “Parameters” contains the description and units; the column “reference names” contains the name used in the rest of the paper. The lowest row shows examples of the inputs. Note that we report the units for reference, although data is normalized before training.

Tanker ships	
Parameters	Reference names
ETA from ship agent (days)	ETA
Distance to go (nautical miles), longitude (minutes), latitude (minutes)	Togo, lon, lat
Speed over ground (m/s), speed (m/s), current (m/s)	Sog, speed, current
Length of ship (m), width of ship (m)	L, W

ETA	togo	lon	lat	sog	speed	current	L	W
9.002755	-2281.923471	14.718662	35.955472	9.8	5.041556	0.000000	140	16
8.343623	-1786.563820	4.031937	42.265273	10.9	5.607444	0.000000	121	16
7.521690	-1625.873423	0.874212	40.117428	9.9	5.093000	0.000000	110	17
1.318519	-292.444956	-4.846972	49.089602	11.7	6.499943	-0.480943	183	32
4.676887	-1290.151316	-5.347252	36.024025	12.5	6.430556	0.000000	144	23

Container ships												
Parameters						Reference names						
ETA from ship agent (days)						ETA						
Distance to go (nautical miles), longitude (minutes), latitude (minutes)						Togo, lon, lat						
Speed (m/s), current u-component (m/s), current v-component (m/s)						Speed, Uc, Vc						
Wind u-component (m/s), wind v-component (m/s), significant wave height (m), peak wave period (s), peak wave direction (degrees)						Uw, Vw, Swh, perpww, dirpw						
Length of ship (m), width of ship (m)						L, W						

ETA	togo	lon	lat	speed	Uc	Vc	Uw	Vw	swh	perpw	dirpw	L	W
1.583333	-309	-5.157166	48.972832	5.144440	0.659586	0.546071	-1.079688	6.472362	2.847386	10.823913	-114.792012	332	58
6.262581	-2301	15.062530	36.118919	9.774436	0.016871	-0.080126	5.416632	-1.500365	0.855043	6.166969	-43.900309	368	51
1.243102	-319	-5.369683	48.871719	6.327661	0.379090	0.164241	3.463899	-5.355926	1.226370	10.860185	-58.268882	170	26
0.062616	-1	2.489342	51.696560	7.099327	0.383567	0.725290	-4.978506	-2.271102	0.092958	6.000000	-3.115260	274	48
3.503704	-818	-9.947200	41.360970	5.453106	0.096709	-0.038865	3.554848	0.061528	0.625368	7.031496	-37.821262	273	48

4 Results

4.1 Influence of predicting uncertainties on prediction accuracy

In Figure 1 we compare the accuracy of our uncertainty-aware deep neural network with other predictions, one obtained by using a simple naïve model, the other obtained by the ship agent. The naïve model predicts the ETA through a very simple physical model, as the distance to destination (Togo) divided by the vessel's speed. The ship agent is the method currently in use on board of vessels.

The comparison is made on the base of the normalized relative error of the predicted ETA with respect to the actual ATA ($error = \frac{\sqrt{(ATA-ETA)^2}}{ATA}$), where the predicted ETA is obtained in three different ways. The median of the relative errors per bin of actual arrival time is computed and shown for increasing values of ATA.

This figure indicates that the deep neural network always gives a better prediction than the naïve model, while its prediction is more accurate than the ship agent estimation for ATAs lower than 7 days. This information can be used when implementing the prediction in the planning process to decide which method to rely upon depending on the location of the ship (distance to destination).

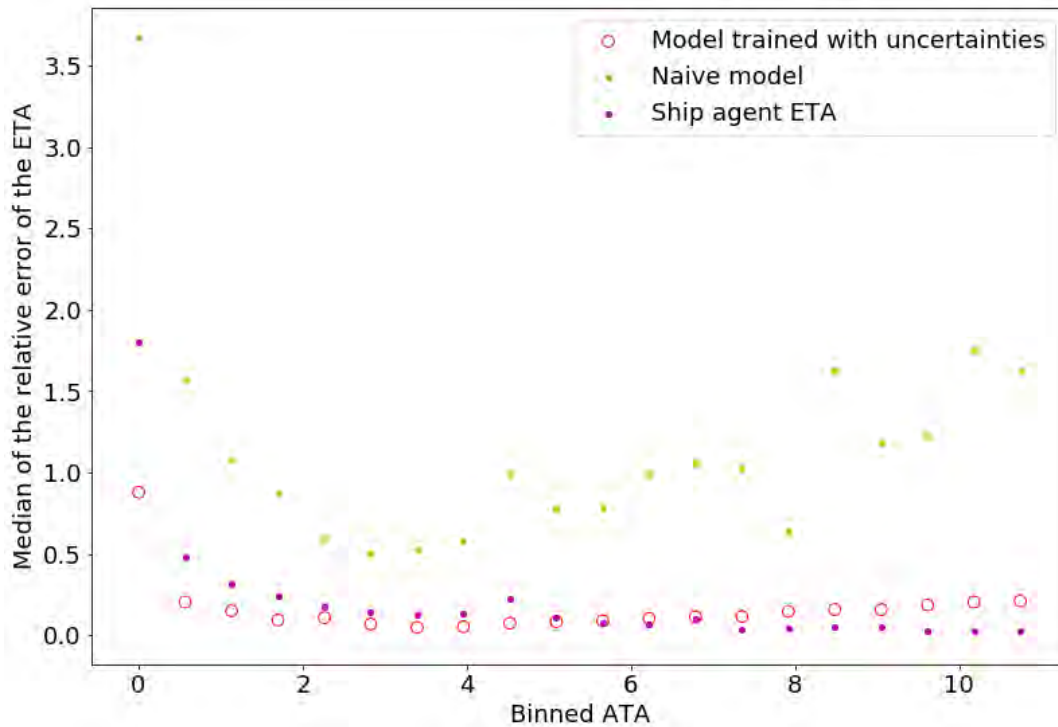

Figure 1: Relative error made in ETA prediction for an uncertainty-aware deep neural network (red circles), a naïve model (green points) and a ship agent (purple points), shown for increasing values of ATAs. The ATA values are binned and the median of the relative error per bin is shown on the y-axis.

4.2 Checking the distribution of uncertainties

Figure 2 is the results of the second experiment, performed to validate whether the actual distribution of ATAs follows a normal distribution.

The blue-filled curve is the distribution of the location of the ATAs, relative to the (normalized) predicted ETAs. This ‘relative location’ is calculated as $ATA_{plot,i} = \frac{ATA_i - \mu_{ETA_i}}{\sigma_{ETA_i}}$ per each vessel’s data point i , given its actual ATA, the predicted ETA (μ) and predicted uncertainty (σ) for that data point. In red, a normal distribution with mean 0 and standard deviation 1 is shown for reference.

Distribution of ATAs projected on the normalized predicted distributions

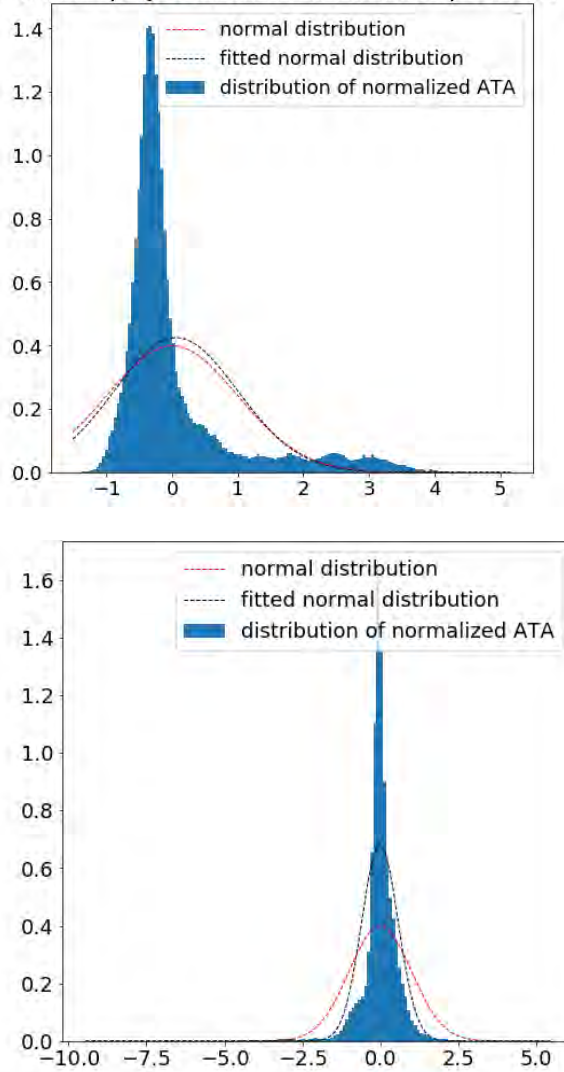

Figure 2: In blue, distribution of the ATAs relative to the predicted ETAs (on the x-axis: $ATA_{plot,i} = \frac{ATA_i - \mu_{ETA_i}}{\sigma_{ETA_i}}$, per vessel's data point i), for container ships (above) and tanker ships (below). In red a normal distribution with mean 0 and standard deviation 1 is shown for reference; in black, the normal distribution obtained by fitting the blue curve.

The figure shows that the assumption of a normal distribution does not hold well for container ships: the actual distribution of true data points is narrower than predicted for data points close to the predicted means and manifests a long asymmetric tail. The assumption is better holding for tanker ships, although the fitted normal distribution to the data points (black dashed line) appears anyway narrower than the predicted normal distribution.

In this figure we can see that the assumption of a normal distribution of predicted values is not a reasonable assumption, hence the predicted uncertainty should not be interpreted as standard deviation from the mean. Additionally, uncertainties predicted by our network are somewhat pessimistic (overestimations) compared to the location of the actual arrival time in these distributions.

This becomes also clear in Figure 3: for different partitions of the distribution (obtained by varying n and selecting each time a range $n * \sigma$), the percentage of data points captured within that partition is plotted for the normal distribution against our predicted distributions. When the

captured percentage from our distribution is higher than that from the normal distribution, as happens in both figures, our network is too pessimistic. This shows that when we assume a normal distribution, we predict in most of the cases a much larger uncertainty than needed (conservative estimation or overestimation). Only for a few values for container ships (see Figure 3 left, top corner) the uncertainty is slightly underestimated; for these data points, which fall in the partition far from the predicted mean ($>3\sigma$), our network is too optimistic and the uncertainty should be higher to capture the actual arrival time.

Considering that the underestimated uncertainties only occur in 5-10% of the cases, these experiments show that our network mostly capture the actual arrival time. The fact that the uncertainty predictions are overestimated most of the time provide an acceptable scenario for risk-avoidance planning.

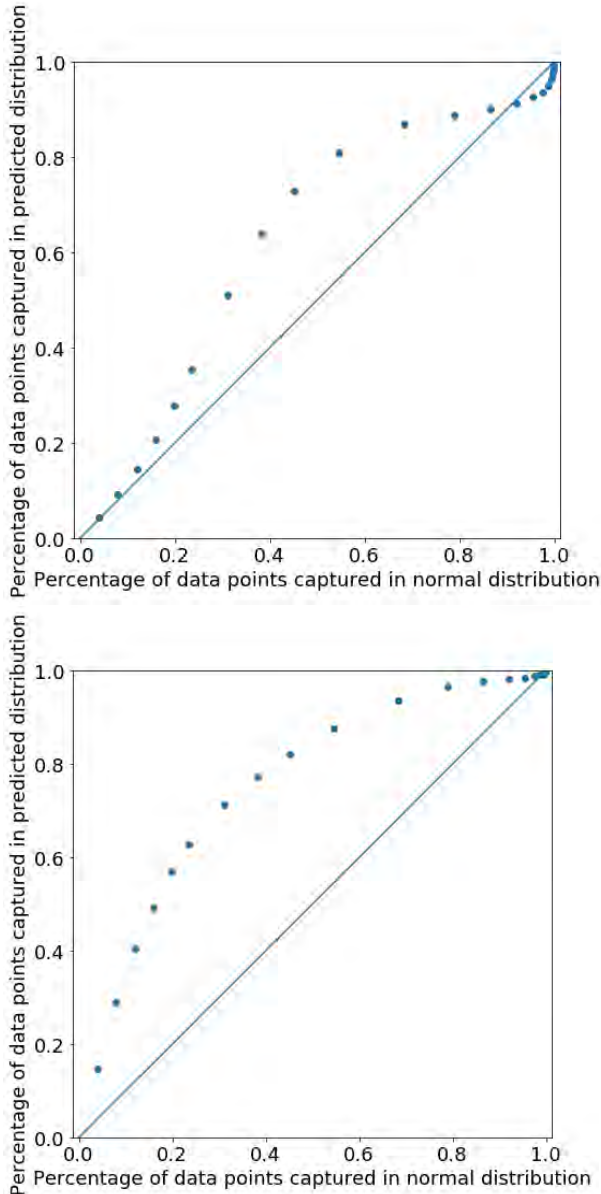

Figure 3: Difference between the real distribution of error and a normal distribution with the calculated σ for container ships (left) and tanker ships (right). The partitions of the distributions ($n * \sigma$) are varied and the percentage of the data points captured within these partitions is calculated for the normal distribution (x-axis) and our predicted distribution (y-axis).

4.3 Data quantity

To optimize logistic chain processes through data-driven predictions, insight on the influence of data necessity is required. Typical questions are: would it be useful to train the network with more data; should we collect data from more trips?

To assess the influence of the number of trips used in the training set, we train the same network architecture with an increasing number of trips and evaluate the network uncertainties on the same test set. The experiments are repeated 10 times and their uncertainties are averaged. The results are shown in Figure 4 and Figure 5.

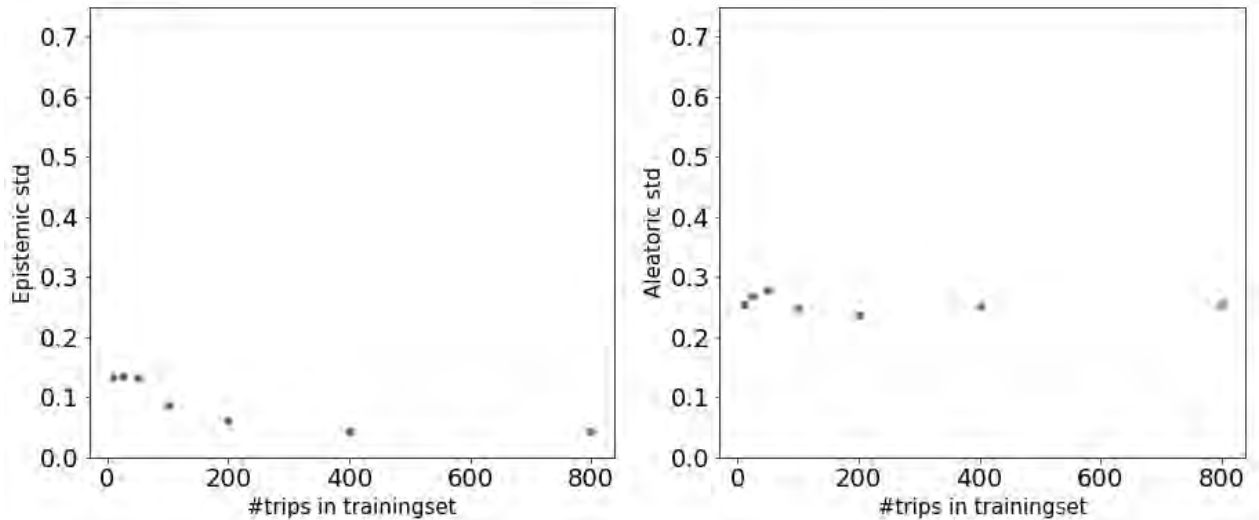

Figure 4: Influence of the number of trips in the training set on the uncertainty of the network. The uncertainties are averaged for 10 repeated experiments. Results are shown for the container ships; on the left side the epistemic uncertainty; on the right side the aleatoric one.

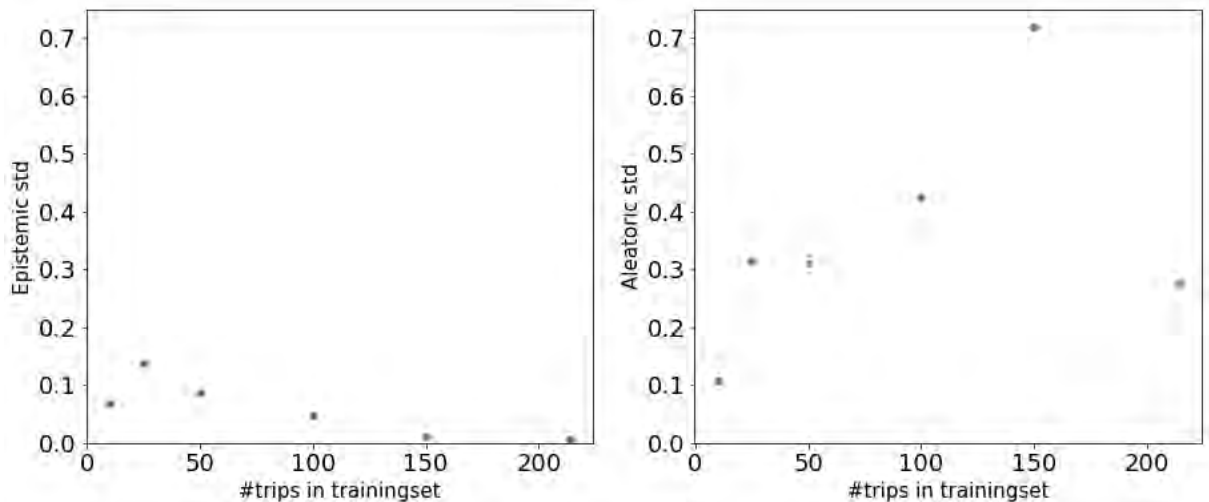

Figure 5: Influence of the number of trips in the training set on the uncertainty of the network. The uncertainties are averaged for 10 repeated experiments. Results are shown for the tanker ships; the large outliers visible at 100 and 150 trips are understood as an effect of the more unpredictable behavior of the tanker ships that sometimes stop for several days due to the fluctuations in the price of oil.

For both types of ships, the Epistemic uncertainty (left plots) is the one mostly affected by the quantity of data, while the Aleatoric uncertainty (right plots) does not change much with

training data size. This is expected by the difference between these two uncertainties (see also Section 2.2).

The figures also show that the Aleatoric uncertainty dominates the total uncertainty for container ships. This means that the amount of data used for training is not the limiting factor and that collecting more data (of the same type) would not help to reduce the total uncertainty. In general, the same holds for the tanker ships, except that the Aleatoric uncertainty shows here some large outliers at 100 and 150 trips. This is understood as an effect of the more unpredictable behavior of the tanker ships that sometimes stop for several days due to the fluctuations in the price of oil.

4.4 The importance of domain expertise in a data-driven approaches

The predictions and uncertainties obtained by networks trained on different sets of input parameters are shown in Figure 6 and Figure 7. The parameters are chosen based on their expected influence on the arrival time on the base of domain expertise. The most valuable parameters which contain the ETA and the distance to go are shown as circles, the parameters that do not contain the ETA or the distance to go are shown as squares, and a reference set that contains only the speed and the distance to go is shown as an x.

Each point in the figure represents the averaged uncertainties of the ETA prediction (*std*, x-axis) for a network trained on a set of input parameters, as indicated in the legend. The error on that average, calculated as the absolute difference between the network's prediction and the actual time of arrival, is showed on the y-axis. This means that the points in the figure with lowest error give the most accurate estimations of the set of experiment with respect to the actual times, and the points with the lowest *std* give predictions with the lowest uncertainty. The dashed grey line indicates the ideal case where the estimated uncertainty *std* also corresponds to the actual error.

The figures show that for both types of ships, both the ETA (of the ship agent) and the distance to go are important parameters to get accurate results (circular point markets).

For container ships, just using the speed and the distance to go also gives a comparable result as experiments also using the ETA (cross point). Additionally, an interesting point in Figure 6 is the experiment that does not use the ETA but uses the latitude, longitude and speed; this experiment has comparable results to the speed and distance to go experiment (see cross marker and yellow marker). This shows that the network obtains better results if it has information on the distance to destination, either given by the Togo parameter or contained in the latitude and longitude parameters.

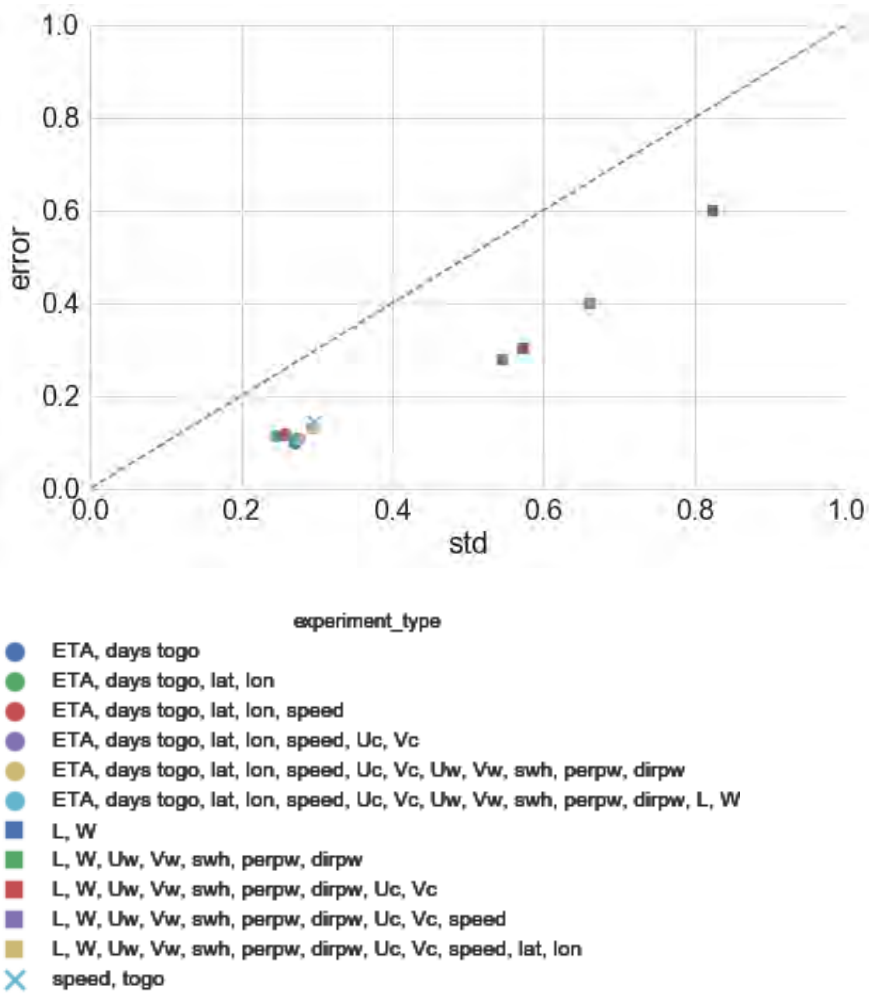

Figure 6 Results for the container ships. On the x-axis, averaged uncertainties on the ETA prediction for networks trained on different input parameters; the experiments are repeated 10 times and the mean uncertainty is averaged. On the y-axis, the difference between the predicted ETA and the actual ATA. The networks are trained with a varying set of parameters. The parameters are chosen based on their expected influence on the arrival time on the base of domain expertise. The most valuable parameters which contain the ETA and the distance to go are shown as circles, the parameters that do not contain the ETA or the distance to go are shown as squares and a reference set that contains only the speed and the distance to go is shown as an x. The dashed gray line is the $y=x$ line.

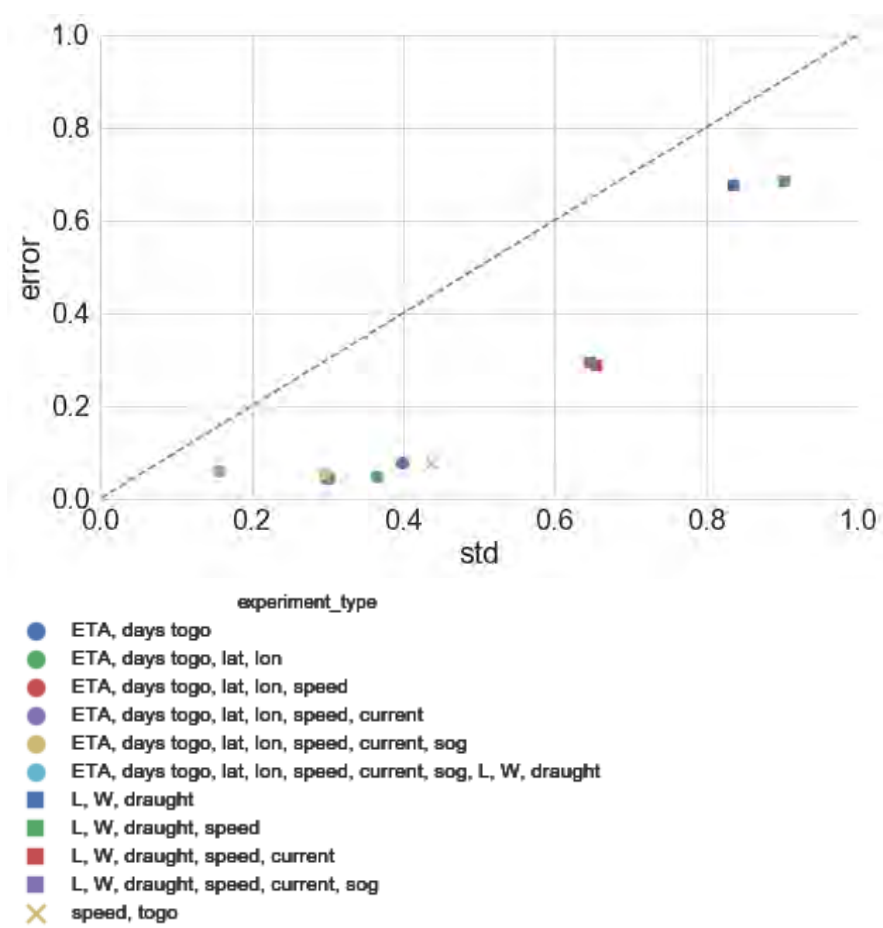

Figure 7 Results for the tanker ships. Same axes as in Figure 6.

An interesting observation for tanker ships is that the experiment showing the lowest *std* (light blue circle marker) uses all parameters, including the draught of the ship. Information on the form of this tanker ship seems therefore to strongly influence the predicting power of the network.

In conclusion, both Figure 6 and 7 show that the most accurate network are those using ETA, distance to go, latitude, longitude, speed and current. The results of a network using all available parameters, or a network just using speed and distance to go only, are comparable with those relying on the mentioned subset.

This experiment illustrates that, in case of limited data collection resources, domain expertise is a valuable addition to a data-driven approach. It allows, for example, to prioritize the data collection choices to maximize prediction performance.

5 Conclusion and Future Outlook

5.1 Conclusion

We presented an uncertainty aware deep neural network for arrival time prediction in logistics.

We show that the assumption of predicting normally distributed values does not hold well, especially for the containerships dataset. We also show that such network performs better than a naïve physical model, and mostly better than the currently used method (ETA estimation of the ship agent), if the prediction is given at not-to-high distance to destination.

Additionally, we note that the predicted uncertainty is an overestimate of the real uncertainty of the error of the model, hence our network mostly captures the actual arrival time and provides an acceptable scenario for risk-avoidance planning.

We investigate the effects of the amount of training data on the uncertainties, and we verify, as expected, that it is mainly the epistemic uncertainty to be affected by the amount of data. Since in our validation experiments the aleatoric uncertainty dominates the total uncertainty, the amount of data is not the limiting factor in this case, and collecting more data (of the same type) would not help to reduce the total uncertainty.

Finally, we investigate the influence of the different parameters of the neural network on the error (accuracy) and uncertainty. We conclude that only using parameters that are expected to be of large influence on the arrival time, on the base of domain expertise, provides a network with a higher or comparable accuracy to that obtained when no domain expertise is employed for the selection. This comparison shows that domain expertise is a valuable addition to a pure data-driven approach, for example if there are limited data collection resources and one needs to decide which parameter to focus on to maximize performance.

The results of our work show the value of adding uncertainty to a neural network in the prediction of time of arrivals of vessels for a logistic application.

5.2 Research outlook

We have several recommendations for future study and experiments on this topic. First, we predict the arrival time only on the base of data of the current moment in time; an improvement on this choice could rely on an expansion on temporal information of the route, which could be incorporated into the network using, for instance, a Recurring Neural Network. Furthermore, it is known that weather influences the ETA greatly and taking the predicted weather into account could lead to a better estimation. Also, tanker ships sometimes delay their arrival depending on the fluctuations in the financial market (e.g., if the price of oil is low or expected to rise in the coming days); this kind of information could also be incorporated into the network. Finally, here we only look at a small link in the total logistics chain; to get a complete estimate of uncertainty in the entire chain, uncertainty should be added to more processes in this chain, for example to the prediction of duration of certain shipping processes on land or of other logistic segments at the port.

6 References

- Fancello, G., Pani, C., Pisano, M., Serra, P., Zuddas, P., & Fadda, P. (2011). Prediction of arrival times and human resources allocation for container terminal. *Maritime Economics & Logistics*.
- Freitas, J. F. (2003). *Bayesian Methods for Neural Networks*. University of Cambridge.
- Gal, Y., & Ghahramani, Z. (2016). Dropout as a Bayesian approximation: representing model uncertainty in deep learning. *arXiv: Machine Learning*, 1050-1059. Retrieved 4 9, 2018, from <http://proceedings.mlr.press/v48/gal16.html>
- Gal, Y., Hron, J., & Kendall, A. (2017). *Concrete Dropout*. Retrieved 4 9, 2018, from <https://nips.cc/conferences/2017/acceptedpapersinitial>
- Gómez, R., Camarero, A., & Molina, R. (2015). Development of a Vessel-Performance Forecasting System: Methodological Framework and Case Study. *Journal of Waterway, Port, Coastal, and Ocean Engineering*.
- MaritiemNieuws (2017). *Havenbedrijf Rotterdam enthousiast over standaarden nautische haveninformatie*. (2017, 09). (Maritiemnieuws) Retrieved 04 2018, from

- <https://maritiemnieuws.nl/81486/havenbedrijf-rotterdam-enthousiast-over-standaarden-nautische-haveninformatie/>
- Kendall, A., & Gal, Y. (2017). What Uncertainties Do We Need in Bayesian Deep Learning for Computer Vision. *arXiv: Computer Vision and Pattern Recognition*, 5580-5590. Retrieved 4 9, 2018, from <https://nips.cc/conferences/2017/acceptedpapersinitial>
- Lane, R., Nevell, D., Hayward, D., & T, B. (2010). Maritime anomaly detection and threat assessment. *13th International Conference on Information Fusion IEEE*.
- Meijer, R. (2017). *Predicting the ETA of a container vessel based on route identification using AIS data*. MSc Thesis TU Delft.
- Nevell, D. (2009). Anomaly detection in white shipping. *Mathematics in Defence*.
- Pallotta, G., Vespe, M., & K, Bryan. (2013). Vessel Pattern Knowledge Discovery from AIS Data: A Framework for Anomaly Detection and Route Prediction. *Entropy*, 2218–2245.
- Parolas, I. (2016). *ETA prediction for containerships at the Port of Rotterdam using Machine Learning Techniques (Master's thesis)*. Delft University of Technology.
- Salleh, N., Riahi, R., Yang, Z., & Wang, J. (2017). Predicting a Containership's Arrival Punctuality in Linear Operations by Using a Fuzzy Rule-Based Bayesian Network (FRBBN). *The Asian Journal of Shipping and Logistics*.
- Williams, C. K., & Rasmussen, C. E. (2006). *Gaussian Processes for Machine Learning*. The MIT Press. Retrieved 4 9, 2018, from <http://www.gaussianprocess.org/gpml/>

Inventory Control under Possible Delivery Perturbations in Physical Internet Supply Chain Network

Maroua Nouiri¹, Abdelghani Bekrar¹ and Damien Trentesaux¹

¹ LAMIH Laboratory, UMR CNRS 8201, University of Valenciennes and Hainaut Cambrésis, Le Mont Houy, 59313, UVHC, Valenciennes, France.

Corresponding author: maroua.nouiri@gmail.com

Abstract: *This paper investigates the inventory control management confronted to possible delivery perturbations in classical and Physical Internet Supply chain Networks. The "Physical internet" is a new paradigm that aims to integrate independent logistics networks into a global, open interconnected logistics system. This work represents a simulation study that aims to assess the performance of physical internet face to external disruptions in routes. Two simulation models are proposed to test both the classical supply chain network and the Physical Internet supply chain. We consider a supply chain network configuration from the literature. We propose also two scenarios while varying retailers' demands strategy and the truck's number and capacity. Several key performance indicators (KPIs) are considered to evaluate the performance of both networks, such as resources usage, transportation cost, holding cost and delivery delays.*

Keywords: *Physical Internet, Inventory Control, Delivery Perturbations, Replenishment, Simulation*

1 Introduction

Logistics organizations are nowadays expected to be efficient, effective, and responsive while respecting other objectives such as sustainability and resilience. In fact, it should be able to deal with increasing demands for goods while satisfying challenging logistical constraints such as demand uncertainty, lead time, and resources availability. Sustainable development has become a crucial issue in recent years owing to the impact of global warming and carbon footprint awareness the sustainable supply chain management (SSCM).

Recently the "Physical Internet" was proposed by Montreuil, B. (2010) as a solution to the global logistics sustainability grand challenge of improving the economic, environmental and social efficiency. Inspired from the digital internet, the Physical Internet is defined as an open and shared network that interconnect independent logistics networks and services. The smart PI-containers, the PI-nodes and the PI-movers are the key types of Physical Internet elements. By analogy with data packets, the goods are encapsulated and shipped in smart PI-containers which are small modular container with standardized sizes. The PI-containers are moved via PI-movers like PI-trucks, PI-vehicle, PI-boats, etc. Once the PI-container are transported, they are received, tested, moved, routed, sorted, handled, placed, stored and picked while using PI-nodes like PI-bridges, PI-Sorter, PI-Switch, PI-Hub, etc (Meller et al., 2012).

This work highlights the interest of the PI concept on resilience and sustainability in logistics management, when facing possible perturbations in delivery control model. We propose two Multi agents based simulation models to test both the classical supply chain network and the Physical Internet supply chain under possible delivery perturbations. The tests are performed on real case data of Fast Moving Consumer Goods companies (FMCG) from the work of Pan et al. (2015). In order to compare the results of the simulation, the same input data and the same configuration are used in the two models. The same scenarios with different probabilities of delivery delays are considered for the two simulation models. Tests are

performed also by varying delivery delays, retailers' demands and the number of trucks in the two simulation models. Several key performance indicators (KPIs) are considered, such as resources usage, transportation cost, storage cost and delivery delays.

The rest of the paper is organized as follows: the next Section provides a literature review on Inventory Control algorithm in physical internet supply chain network. Section 3 contains the details of the classical and physical internet supply chain simulation models. The inventory control algorithm is detailed in Section 4. Simulation scenarios and key performances indicators are reported in Section 5. Section 6 provides the experimental results. Finally a conclusion and future work are given with in Section 7.

2 Literature review

First works have interested on standardized of PI-components and functional design facilities. Montreuil et al, (2012) provide the physical internet concepts and foundations. Similar to the Open Systems Interconnection (OSI) model for the Digital Internet, Montreuil et al. (2012) proposed an Open Logistics Interconnection (OLI) model for the Physical Internet. Physical Internet transportation network design was first tackled by Ballot, Gobet, and Montreuil (2012). Designing Physical Internet container sets has been addressed by Lin et al. (2014) and Gazzard and Montreuil (2015).

A set of facility types that would be necessary to operate a PI are proposed. Such facilities were termed PI-nodes. The complete set of PI-nodes included: transit nodes, switches, bridges, hubs, sorters, composers, stores and gateways (Ballot et al, 2013).

Other works have attempted to evaluate the performance of the physical internet on logistics from an economic, environmental and social point of view. These works are based on analytical optimization and/or simulation modeling based experiments. Many researchers focused on proposing methodologies and models for addressing the impact of Physical Internet on planning and operations decisions in logistic networks. In the literature, much attention is devoted to the collaborative transport planning optimization issue. Sarraj et al. (2014) introduced protocols for PI transportation. They model the asynchronous shipment and creation of containers within an interconnected network of services, and the best path routing for each container and minimize the use of transportation means

Pach et al. (2014), Walha et al. (2014) and Chargui et al. (2018) studied the PI-containers' internal routing problem in PI-hubs (road-rail, road-road, etc). Other authors treated the external routing problem (PI-hubs interconnection); for instance: Kim and Montreuil (2017), Pan et al. (2015) and Yang et al (2015). Kim and Montreuil (2017) studied hyperconnected mixing centers; they proposed a simulation-based methodology to compare three configurations. In the first configuration, the manufacturers can serve the distribution centers of the retailers directly from the plants of the manufacturers. The second configuration uses dedicated mixing centers. In the third configuration, hyperconnected mixing centers are used to serve the distribution centers of the retailers. Their simulation result showed how hyperconnected mixing centers can improve the delivery rate and reduce inventory.

In the literature, much attention is devoted to the inventory control problem. Yang et al (2015) studied the inventory management for fast moving goods in a network of hubs. They proposed a mathematical model for the problem and a simulated annealing heuristic. They compared and evaluated four source selection strategies.

In their work, Pan et al (2015) presented a simulation study for inventory control in the classical supply chain and the Physical Internet supply chain by keeping the same network and data while changing the network interconnectivity.

All previously cited studies do not take into account perturbations when solving the inventory problem in physical internet supply chain.

Recent, Yang et al (2017) have proposed a multi-agent simulation model for the resilience of freight transportation in the Physical Internet while considering random disruptions at the hubs. They proposed two dynamic transportation protocols to deal with various types of disruptions. However, they consider only internal perturbations at hubs.

Our research fits in the scope of evaluating inventory control's performances while considering external perturbations in routes. Two multi-agent based simulation models for both the classical and the Physical Internet supply chain are proposed. Two scenarios are performed on the two simulation models by varying these parameters: the retailers' demands and the number of trucks. The simulation models are detailed in the next Section.

3 Two Multi-agent based simulation Models

3.1 Classical supply chain model

In this simulation, a real case data of Fast Moving Consumer Goods companies (FMCG) from the work of Pan et al. (2015) is considered. Figure 1 illustrates the supply network used in this simulation studies modeled by Netlogo. It is an Agent-based Simulator. Netlogo has four types of agents: "turtles", mobile or static, which are decisional entities; "patches", static, which provide a grid representation of the environment; "links", which are agents that connect two turtles; and "the observer" who is in charge of giving instructions to the other agents. In this study, the supply chain components were modeled with just turtles, breeds and links. Breeds are an agentset of turtles. The classical and physical internet supply chains are designed as network of nodes linked by NodeLinks. These later represent the routes between logistic centers. As we can see in Figure 1, the logistic network is composed from a plant, a warehouse (WC), two distribution centers (DC1, DC2) and two retailers (R1, R2). The designed multi agent model of the supply chain network is composed by five main agents: plant, retailer, warehouse, distributed center and truck. TransportationCost (), Holding Cost (), TrucksUtilization (), DeliveryDelays () are the main functions used to evaluate the performance of the supply chain network. The existing relationships among these agents, and also their main functions are illustrated in the class diagram represented in Figure 2.



Figure 1: Classical supply chain network designed for simulation

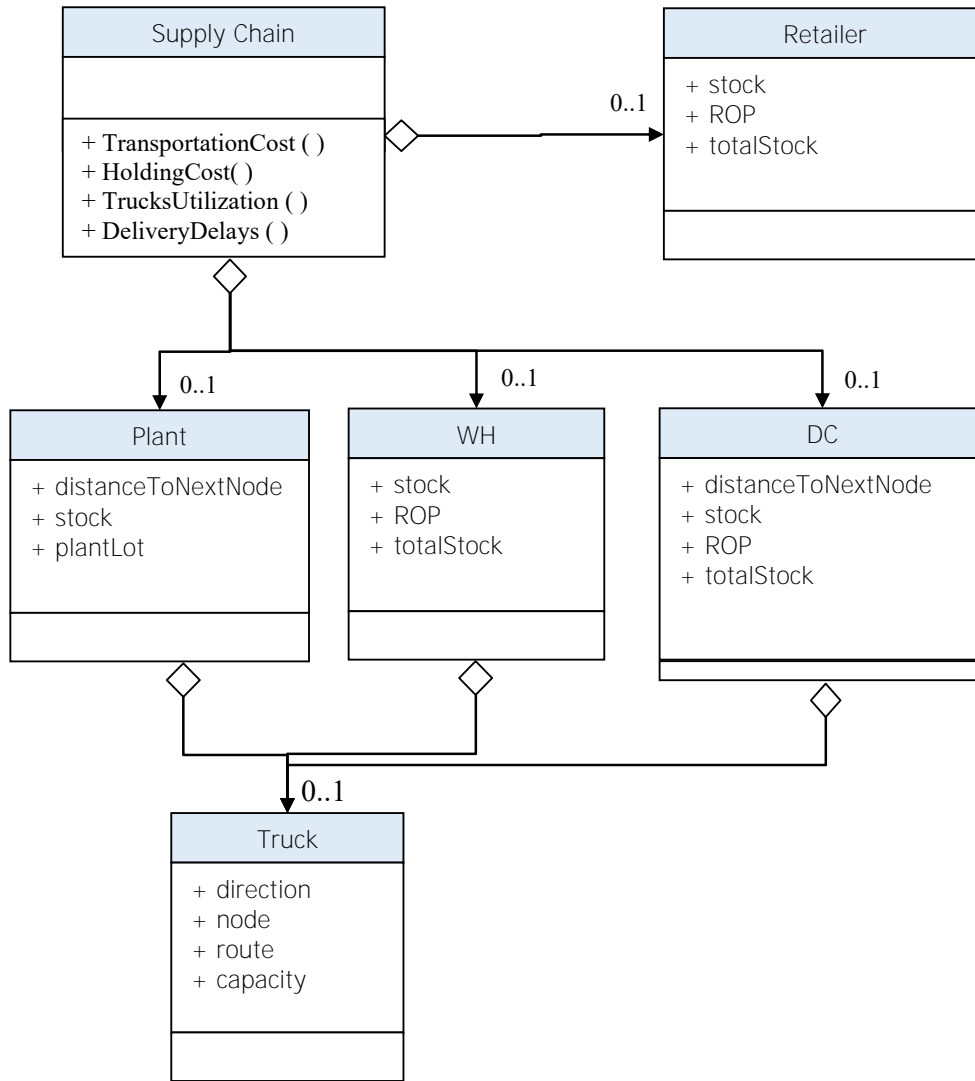

Figure 2: Class diagram of the classical supply chain network

Table 1 represents the fixed simulation parameters used in the classical supply chain network taken from Pan et al. (2015). It is composed of 4 columns. The 8 parameters are fixed in all classical supply chain simulation scenarios. The lead time represents the time needed to deliver the goods to the customers. The lot size represents the quantity of product units used in the procurement process. The reorder point (ROP) represents a level of inventory which triggers a procurement order to replenish that particular inventory stock. The distance between different nodes in the classical supply chain model are summarized in table 2.

In the proposed model, there are many other parameters like number of trucks, the capacity of trucks, the demand of retailers, etc. The value of those parameters is not fixed and changes from one scenario to another. This part is detailed in Section 4.

Table 1: Parameters of experimental simulation of classical model

N°	Parameters	Unit	Value
1	Lead time DC to R	Days	7
2	Lead time WH to DC	Days	10
3	Lead time Plant to WH	Days	14
4	Lot Size Retailer 1	units	76
5	Lot Size Retailer 2	units	90
6	ROP Retailer 1	units	27
7	ROP Retailer 2	units	47
8	ROP WH	units	45
9	ROP DC 1	units	25
10	ROP DC 2	units	25
11	Production Lot to plant	units	1200
12	Lot size WH_DC	units	50
13	Lot size Plant-WH	units	100
14	Stock_init_R1	units	103
15	Stock_init_R2	units	137
16	Stock_init_WH	units	200
17	Stock_init_DC	units	50

Table 2: The distance between nodes in classical supply chain network

Node	Plant	WH	DC1	DC2	R1	R2
Plant	-	700km	-	-	-	-
WH	-	-	350 km	350km	-	-
DC1	-	-	-	-	100km	-
DC2	-	-	-	-	-	100km

3.2 Physical internet supply chain model

In the Physical Internet network, the warehouse and the two distribution centers are replaced by three open PI-Hubs with fully interconnected architecture (see Figure 3). Thus, several new replenishment paths are possible. The only main difference between the two logistics networks is the interconnectivity of network. Table 3 resumes the distance of allowed paths between different nodes. The values marked in blue color in table 3 refer to the distances of new connections in the supply chain network after applying the physical internet paradigm. As we can see from Figure 3, there are new connections between plant and different PI-hubs, fully interconnected network between Pi-hubs and also new connections between hubs and different retailers in the system.



Figure 3: Physical Internet supply chain network designed for simulation

Table 3: The distance between nodes in physical internet supply chain network

Node	Plant	Hub3	Hub1	Hub2	R1	R2
Plant	-	700 km	979 km	979 km	-	-
Hub3	-	-	350 km	350 km	427 km	427 km
Hub1	-	-	-	495 km	100 km	505 km
Hub2	-	-	-	-	505 km	100 km

Figure 4 describes the main input data in both simulation models: the lead time, the Reorder point ROP, the lot size, stock initial and the distance between nodes. The outputs are the transportation cost, the holding cost, the average of resources utilization and the delivery delays. They represent the key performance indicators used in this simulation study. More details of KPI are described in Sub-Section 5.2.

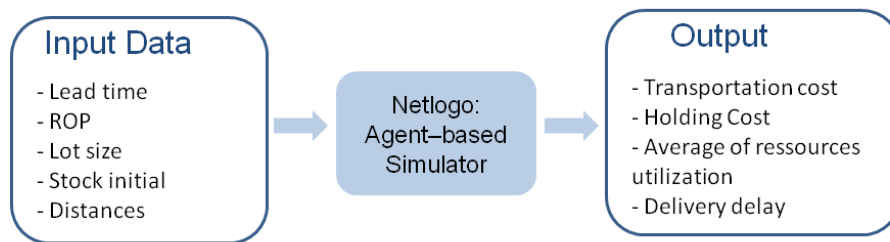

Figure 4: Main Input and output data of the simulation process.

4 Inventory control algorithm

The inventory management is a part of supply chain management and is a key role in the performance of supply chain. This work studies the effect of perturbation, the holding cost variation, the transportation cost and the average of resources utilization in inventory control in classical and physical internet supply chain.

4.1 Inventory control model in classical supply chain

The Figure 5 illustrates the flow chart of the inventory control algorithm in classical supply chain model. After receiving a demand from a lower level, every node compares its stock level with the reorder point (ROP). If the stock level is lower than the ROP, an order of replenishment is sent to the upper level. The right side of Figure 6 represents the lower and upper level of the classical supply chain. As we can see, the upper level of the retailer is the distribution center, the warehouse is the upper level of DC, and the plant is the upper level of WC. Otherwise, if the stock level is greater than ROP, the node sends the order to the client and the stock level is updated. The available stock will be decreased by the ordered quantity.

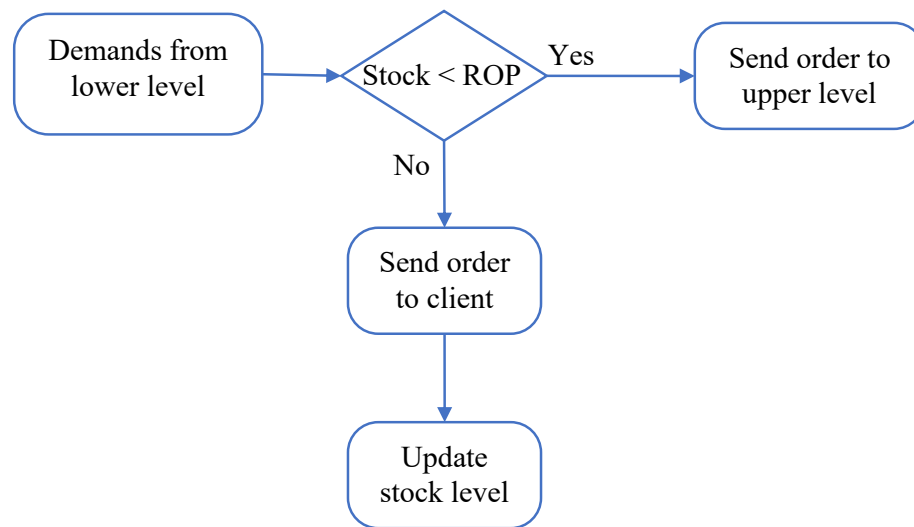

Figure 5: Flow chart of inventory control algorithm in classical supply chain

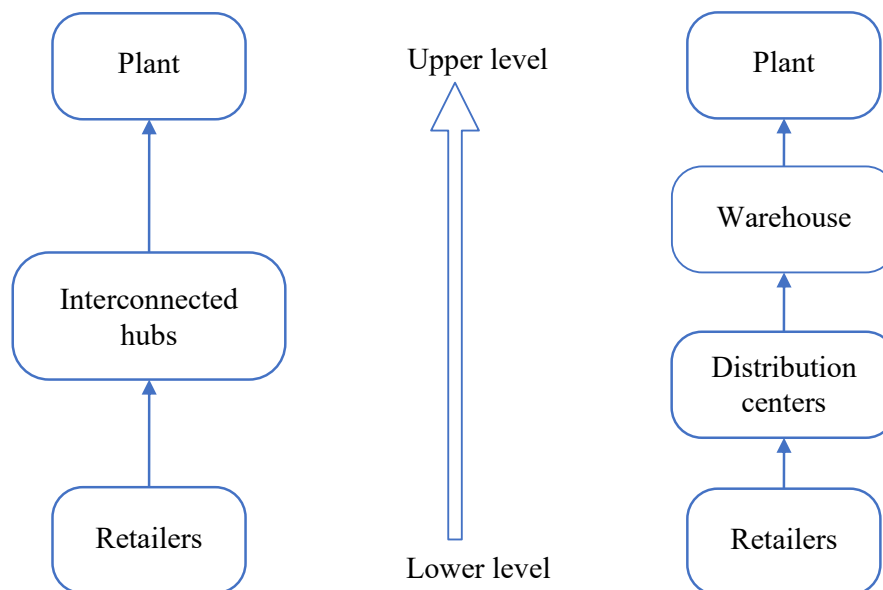

Figure 6: Lower and upper level from classical and PI supply chain

4.2 Inventory control model in physical internet supply chain

The Figure 7 illustrates the flow chart of the inventory control algorithm in physical internet supply chain network. The inventory control algorithm is the same used in the classical supply chain expect some modifications. If the stock level is lower than the reorder point, there isn't only one upper level. The left side of Figure 5 shows that the upper level of retailers is interconnected hubs. The inventory model should select a replenishment source before sending the order.

In fact, physical internet enables more supply and replenishment options. So the upper level is not predefined like in the classical supply chain model. Thus a decision module is needed to be integrated in order to select a replenishment source from the candidates solutions. In this work, the upper level is selected according to its distance and its level of stock. The closest one to the destination (in terms of km) with sufficient available inventory to fill the order is chosen. It means that we select the source that has the lowest distance and that has a sufficient inventory stock.

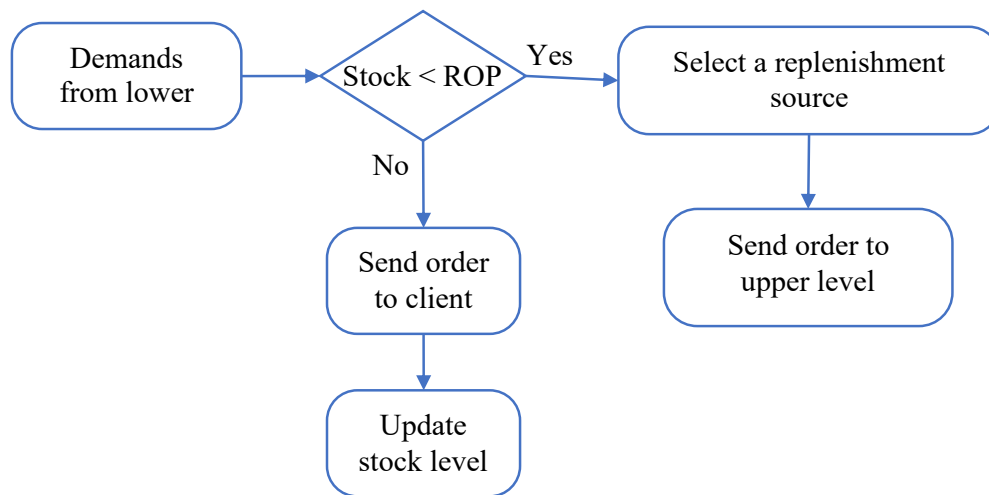

Figure7: Flow chart of inventory control algorithm in physical Internet supply chain network

5 Simulation Scenarios and Key Performance Indicators

The two simulations models are developed using the multi agent environment Netlogo (Wilensky, 1999). This last was chosen for its openness, friendly implementation, its agent-oriented programming approach. This Section gives the details of different scenarios and the KPI used in this simulation study.

5.1 Simulation Scenarios

5.1.1 Scenario 1: Behavior with different number of trucks

A first scenario has been designed to integrate the change in the number of trucks and the capacity of each one. We suppose that each node have the same number of trucks with the same capacity. Table 4 describes different combination of capacities and number of trucks. For example, the low Medium level (2, 30) means that each node have 2 trucks with 30 capacity intern of number of pallets except retailers.

Table 4: The different levels when varying the number of trucks

Capacity of trucks Number of trucks	Low	Medium	High
Low	(2, 20)	(2, 30)	(2, 40)
Medium	(5, 20)	(5, 30)	(5, 40)
High	(10, 20)	(10, 30)	(10, 40)

5.1. 2 Scenario 2: Behavior with different retailers demands

A second scenario has been designed to represent different types of retailer's strategy. We consider three types of demands: daily purchase, periodically purchase or random purchase. Daily demand submits to normal distribution (mean values and standard deviation values) Periodic demand submits to uniform distribution. The last demand strategy is random value between 0 and 45.

Details of different strategy are defined and presented in Table 5.

Table 5: The different type of retailer's demand strategy

Type	Daily demand	Periodic demand	Random
Demand of R1	Mean = 20, S.D. = 4	UNIF(20,40)	Rand (0, 45)
Demand of R2	Mean = 35, S.D. = 7	UNIF(20,40)	Rand (0, 45)

The two scenarios have been submitted to an external perturbation: when an incident is happen in the route that related two nodes. For example, there is failure in the route between DC1 and R1 or the route between WH and DC2, etc. In that way the delivery time is delayed. There are many type of perturbation's level that can occur. The low level is when the delay is between 1 or 2 days, the medium one between 3 and 5 days and the high level is when there is 5 or 8 days delayed. Thus the system should solve the routing problem reactively.

There are also internal perturbations that can happen in supply chain like perturbations inside PI-hub (failed conveying units, forklifts failures, automated storage and retrieval system (AS/RS) , etc). This type of perturbation is not treated in this work.

5.2 The key performances indicators

This Section discusses the key performance indicators used in the simulation models. Transportation cost, Holding Cost, resources utilization and the delivery delays are the functions considered in the simulation model to evaluate the performance of the replenishment policies.

- **The holding Cost:** the inventory cost used in the simulation model is taken from Pan et al 2015 and is calculated as follows:

$$HoldingCost = Volume * days * p \text{ (€/day m}^3\text{)} \quad (1)$$

Where the product unit is measured in a full pallet (which is 1.73 m³), the variable *days* takes 1 value if stocks are present at a hub at day *i*, otherwise it takes 0. The variable *p* refers the cost per day which is equal to 0.11 Euro/ (day m³) if the goods are at the warehouse, distribution center and hub level. At the Retailer's the cost is equal to 0.165 Euro/ (day m³) because the holding inventory at shops is more expensive.

- **The transportation Cost:** For one truck used, the transportation cost function depends on the distance traveled by the truck and the cost per km. It is calculated as follows:

$$Transportation\ Cost = distance * p (\text{€/km}) \quad (2)$$

We suppose that there is full truckload transportation, which is usually the case in the FMCG supply chain. The variable *p* equals to 1.4 €/km taken from Pan et al (2015).

- **The trucks utilization:** In this model, we suppose that each node have its own fleet of trucks. All trucks have the same capacity. The rate of utilization trucks is calculated as follows:

$$Utilisation\ Rate = \frac{\text{Number of trucks used}}{\text{Total number of trucks}}$$

Where the number of trucks used is calculated as follows:

$$\frac{\text{Number of trucks used}}{\text{Total number of trucks}}$$

We calculate also the average of utilization rate as follow

$$\frac{\sum_{i=1}^n \text{Utilisation Rate}_i}{n}$$

- **The average of delivery delays:** that represents the delays that occur during the delivery of goods. It is calculated by number of days

$$\frac{\sum_{i=1}^n \text{Delivery Time}_i}{n}$$

Where the *deliverytime* is the real amount of time that goods take to arrive at their destinations. The *leadtime* is a predefined time needed to deliver the goods.

6 Experiments and simulation results

The simulation models are implemented in the multi-agent programmable modeling environment NetLogo. This tool was chosen for its functionalities allowing distributed control approaches to be modeled naturally. NetLogo contains the appropriate elements to model each decisional entity, its behavior(s) and its interactions with other decisional entities.

All the scenario tests are performed on a machine Intel(R) Core i7 CPU 1.80 GHz with 8GB of RAM. Each scenario is replicated 10 times and is evaluated according to the 4 KPI cited previously.

6.1 Scenario 1: varying number of trucks and capacities

This Section resumes the results of testing the first scenario while varying the number of trucks and their capacities. In this case, the retailer's strategy demand is daily. Table 6 resumes the result of simulation. The table is composed of five columns: the first one indicates the level (number of trucks, capacity), and the others represents the holding cost, transportation cost Trucks Utilization and Average Delivery Delays respectively.

CSC column represents the results of classical supply chain network. The PISC column indicates the results of Physical internet supply chain network.

As we can see from table 6, the physical internet supply chain improves the Holding cost, transportation cost and truck utilization. This is due to the new connections related between hubs. The most improving percentage of trucks utilization is achieved when testing the low medium level and medium high level. When testing the low high level (2, 40), the holding cost is decreased from 71.82 euro to 52.64 euro. The transportation cost is reduced from 1582.93 euro to 1264.87 euro in the low medium level. We can conclude that using low number of trucks with different truck's capacity, there is an improvement in all KPI. However it is still depending on the strategy of the demands and the other input parameters.

Another important conclusion is that the average of delivery delays is null. In fact, the physical internet paradigm allows new routes between logistics centers. Even if connection between R1 and Hub1 is interrupted, the R1 send its demand to the Hub 2 or Hub3.

Table 6: The result of scenario 1

Level	Holding Cost (euro)		Transportation Cost (euro)		Trucks Utilization (%)		Average Delivery Delays	
	CSC	PISC	CSC	PISC	CSC	PISC	CSC	PISC
(2, 20)	69.1	52.3	2212.23	2085.79	48.62	47.52	0.02	0
(2, 30)	69.89	57.21	1582.93	1264.87	31.14	32.7	0.04	0
(2, 40)	71.82	52.64	1224.53	1501.47	21.72	19.87	0.16	0
(5, 20)	66.11	53.98	2315.37	2715.82	20.35	20.3	0.13	0.01
(5, 30)	69.27	69.36	1628.2	1527.2	12.84	12.84	0.1	0
(5, 40)	69.24	66.98	1342.6	1342.6	9.5	10.24	0.05	0
(10, 20)	65.66	45.76	2398.9	2808.9	10.49	10.49	0.2	0.009
(10, 30)	75.14	74.34	1353.8	1214.8	5.32	4.79	0.26	0
(10, 40)	66.45	56.45	1452.73	1172.73	5.12	4.08	0.33	0

6.2 Scenario 2: varying retailer's strategy demand

This Section resumes the results of testing 3 types of retailer's strategy demands. We evaluate the effect of this parameter on KPI values in classical and physical internet supply chain network. In this experiment, the low high level in term of combination (truck, capacity) is used (20, 40). Table 7 resumes the result of simulation.

A closer look on the table 7 shows that the physical internet supply chain improves the Holding cost, transportation cost and truck utilization even if we have different retailer's demands strategy. Main improvements are performed in daily demands. In fact the holding cost is reduced from 71.13 euro to 59.1 euro. The transportation cost is reduced from 1288 euro to 1207.3 euro. The average of delivery delays is null in the physical internet supply chain when facing perturbations in routes.

Table 7: The result of scenario 2

Level	Holding Cost		Transportation Cost		Trucks Utilization		Delivery Delays	
	CSC	PISC	CSC	PISC	CSC	PISC	CSC	PISC
Daily Demand	71.13	59.1	1288	1207.3	22.7	19.65	0.18	0
Periodic Demand	56.94	48.3	1878.33	1645.32	33.32	28.89	0.06	0
Random Demand	102.92	98.45	95.67	76.23	1.779	2.69	0.17	0

5 Conclusion

In this paper, two multi-agent simulation models were developed to test the performance of both the classical and the Physical Internet supply chain in term of transportation cost, holding cost, resources utilization and delivery delay. Different scenarios have been performed by varying the number of trucks and their capacities, the retailers' demand strategies and the level of perturbations. The results showed that the physical Internet supply chain is more efficient compared to classical supply chain. The Holding cost, the transportation cost, the average truck utilization and the average of delays are improved. Another interesting prospect concerns the simulation of the effect of physical internet on supply chain network composed from many plants and grouping centers while considering various types of products. Next studies will be led on the integration of external routing constraints for trucks between hubs while considering perturbations and time windows.

6 Acknowledgements

The research work presented in this paper comes from the ELSAT2020 project of CPER sponsored by the French Ministry of Sciences, the Haut de France region and the FEDER and the national ANR project Pi-Nuts.

References

- Ballot E., Gobet O., Montreuil B. (2012): Physical Internet Enabled Open Hub Network Design for Distributed Networked Operations. In: Borangiu T., Thomas A., Trentesaux D. (eds) Service Orientation in Holonic and Multi-Agent Manufacturing Control. Studies in Computational Intelligence, vol 402. Springer, Berlin, Heidelberg.
- Chargui T., Bekrar A., Reghioui M., Trentesaux D. (2018): Simulation for PI-Hub Cross-Docking Robustness. In: Borangiu T., Trentesaux D., Thomas A., Cardin O. (eds) Service Orientation in Holonic and Multi-Agent Manufacturing. Studies in Computational Intelligence, vol 762. Springer, Cham
- Gazzard N., Montreuil B. (2015): A Functional Design for Physical Internet Modular Handling Containers, 2nd International Physical Internet Conference, Paris, France, July 06-08, p. 19.
- Kim N., Montreuil B. (2017): Simulation-based Assessment of Hyperconnected Mixing Center Capacity Requirements and Service Capabilities. International Physical Internet Conference, July 4-6, 91-106.

Lin Y. H., Meller R. D., Ellis K. P., Thomas L. M., Lombardi B. J. (2014): A decomposition-based approach for the selection of standardized modular containers. *International Journal of Production Research*, 52(15), 4660-4672.

Meller R.D., Montreuil B., Thivierge C., Montreuil Z. (2012): Functional Design of Physical Internet Facilities: A Road-Based Transit Center, in *Progress in Material Handling Research: MHIA*, Charlotte, NC.

Montreuil B., Ballot E., Fontane F., (2012): An Open Logistics Interconnection model for the Physical Internet Proceedings of the 14th IFAC Symposium on Information Control Problems in Manufacturing, Bucharest, Romania, May 23-25.

Montreuil B., Meller R. D., Ballot E. (2010): Towards a physical internet: The impact on logistics facilities and material handling systems design and innovation. In *Proceedings of the International Material Handling Research Colloquium (IMHRC)*, 1–23.

Montreuil B., Meller R. D., Ballot E. (2012): Physical Internet Foundations, *Proceedings of the 14th IFAC Symposium on Information Control Problems in Manufacturing Bucharest, Romania, May 23-25*.

Pach C., Sallez Y., Berger T., Bonte T., Trentesaux D., Montreuil, B. (2014): Routing management in physical internet crossdocking hubs: Study of grouping strategies for truck loading. In: B. Grabot, B. Vallespir, S. Gomes, A. Bouras, D. Kiritsis (eds.) *Advances in Production Management Systems. Innovative and Knowledge-Based Production Management in a Global-Local World*, pp. 483–490. Springer Berlin Heidelberg, Berlin, Heidelberg.

Pan S., Nigrelli M., Ballot E., Sarraj R., Yang Y., (2015): Perspectives of inventory control models in the Physical Internet: A simulation study, *Computers & Industrial Engineering*, Volume 84, 122-132.

Sarraj R., Ballot E., Pan S., Montreuil B. (2014): Analogies between internet network and logistics service networks: challenges involved in the interconnection. *Journal of Intelligent Manufacturing* 25, 1207–1219.

Walha F., Bekrar A., Chaabane S., Loukil T. (2014): A rail-road PI-hub allocation problems: model and heuristic, *Proceedings of 1st International Physical Internet Conference (IPIC 2014)*, Québec, Canada, 1-12.

Yang Y., Pan S., Ballot E. (2015): A model to take advantage of Physical Internet for vendor inventory management, *IFAC-PapersOnLine*, Volume 48, Issue 3, 1990-1995.

Yang Y., Pan S., Ballot E. (2017): Freight Transportation Resilience Enabled by Physical Internet, *IFAC-PapersOnLine*, Volume 50, Issue 1, 2278-2283.

A Mathematical Formulation and Tabu Search Approach for the Road-Rail Assignment Problem

Tarik Chargui^{1,2}, Abdelghani Bekrar¹, Mohamed Reghioui², and Damien Trentesaux¹

1. LAMIH Laboratory, UMR CNRS 8201, University of Valenciennes and Hainaut
Cambrésis, Le Mont Houy, 59313, UVHC, Valenciennes, France

2. RSAID Laboratory, National School of Applied Sciences, ENSATe, University of
Abdelmalek Essaadi, Tetouan, Morocco

Corresponding author: tarik.chargui@gmail.com

Abstract: *Inspired from the digital internet, the Physical Internet (PI) is defined as a global standardized and interconnected logistics system. This paper studies the Road-Rail assignment problem which consists on assigning inbound trucks to the PI-docks and assigning the unloaded PI-containers to the train's wagons. A mixed integer linear programming mathematical model (MILP) is proposed with the objective to minimize both the number of used wagons and the internal travel distance by the PI-containers from the PI-docks to the wagons. Moreover, a heuristic based on the first fit algorithm is proposed for generating an initial grouping of containers and a tabu search meta-heuristic is used after to find better solutions. Finally, the proposed methods are tested on several instances and the obtained results are presented.*

Keywords: *Physical Internet, Road-Rail PI-hub, MILP Mathematical Model, first fit algorithm, Tabu Search.*

1 Introduction

1.1 Physical Internet

Recently, a novel Supply Chain Management paradigm named Physical Internet (PI) has attracted the attention of both the academic and the industrial community. Physical Internet is defined as a worldwide interconnected open logistics system aiming to change the way goods are handled, moved, stored and shipped based on the metaphor of the Digital Internet. The Physical Internet is based on the physical and digital inter-connectivity of the supply chain by encapsulating freight in modular PI-containers as data packets in the TCP-IP protocol. The objective of the Physical Internet is the sustainability of the logistics systems in three aspects: economical, environmental and social (Montreuil et al. 2010; Meller et al. 2012).

Sarraj et al. (2014); Montreuil et al. (2010) presented the three key elements to exploit the Physical Internet: PI-containers, PI-movers and PI-nodes. PI-containers are standardized containers and they can be handled and stored by different companies. PI-movers are used to move and handle PI-containers such as PI-vehicles (PI-trucks, PI-left ...) and PI-carriers (PI-wagons, PI-trailers ...). The PI-nodes are locations for receiving, storing and transferring PI-containers between PI-movers. The PI-nodes can be PI-transits, PI-switches, PI-bridges or PI-hubs.

As the literature of Physical Internet is steadily growing, several papers reviewed the previous contributions on the Physical Internet; for instance, Treiblmaier et al. (2016) reviewed papers on the Physical Internet, and categorized them depending on the research methodologies (Quantitative modeling, Case studies, Simulation ...).

1.2 Road-Rail PI-hubs

This paper focuses on the Road-Rail PI-hub which is designed to transfer PI-containers from trains to other trains, from trucks to trains and from trains to trucks. Road-Rail PI-hubs are composed from three main PI-sorters: Rail-Road PI-sorters to transfer PI-containers from wagons to trucks, Road-Rail PI-sorters to transfer PI-containers from trucks to wagons and Rail-Rail PI-sorter to transfer PI-containers between trains.

The Rail-Road PI-hub was addressed by many researchers; for instance, Pach et al. (2014) proposed different grouping strategies for loading PI-containers in the trucks. Their study showed the effect of the grouping of PI-containers on minimizing the evacuation time in the Road-Rail PI-hub. In addition, Walha et al. (2014) studied the Rail-Road PI-hub allocation problem, which considers the train unloading section of the PI-hub that is used to transfer PI-containers from wagons to trucks. Their paper proposed also a mathematical formulation and a heuristic to find the best assignment of trucks to docks while minimizing the internal distance covered by the PI-containers from wagons to trucks.

In another work, Walha et al. (2016) suggested a simulated annealing meta-heuristic for solving the Rail-Road allocation problem to minimize the distance travelled by the PI-containers. They also proposed a multi-agent based approach which generates solutions while considering perturbations. The dynamic approach takes into consideration the filling rate and the travelled distance.

In this paper, a mathematical model of the Road-Rail PI-hub assignment problem is proposed. The objective is to minimize the number of used wagons and the internal travel distance of the PI-containers from trucks to wagons. The main constraint is that the PI-containers with the same destination must be loaded and grouped in consecutive wagons. Also, a truck has to free the dock once all the PI-containers are unloaded. A first fit based heuristic and a tabu search meta-heuristic are proposed to solve the Road-Rail PI-hub assignment problem. The objective of the first fit algorithm is to find an initial grouping of containers while keeping PI-containers with the same destination in consecutive wagons. The obtained grouping and the truck assignment are then improved using a tabu search meta-heuristic based on several local search moves.

The remaining of this paper is organized as follows. The description of the problem and the proposed MILP mathematical formulation of the Road-Rail PI-hub assignment problem are detailed in sections 2 and 3 respectively. In section 4, the first fit based heuristic and the tabu search meta-heuristic are presented. Finally, the obtained results on several instances are summarized in section 5.

2 Problem description

In this paper, we consider a Road-Rail PI-hub assignment problem. In their paper, Walha et al. (2014) formulated mathematically the allocation of the PI-containers to the Rail-Road section (Section 1 in Figure 1), where the PI-containers are unloaded from the wagons and transferred through the PI-Sorter and then loaded into the outgoing trucks.

Our research focuses on the Road-Rail section (Figure 1) which deals with the transfer of the PI-containers from trucks to wagons. The train is composed of thirty empty wagons. Each five wagons are considered as a block. The wagons will be loaded with the PI-containers that are unloaded from the trucks.

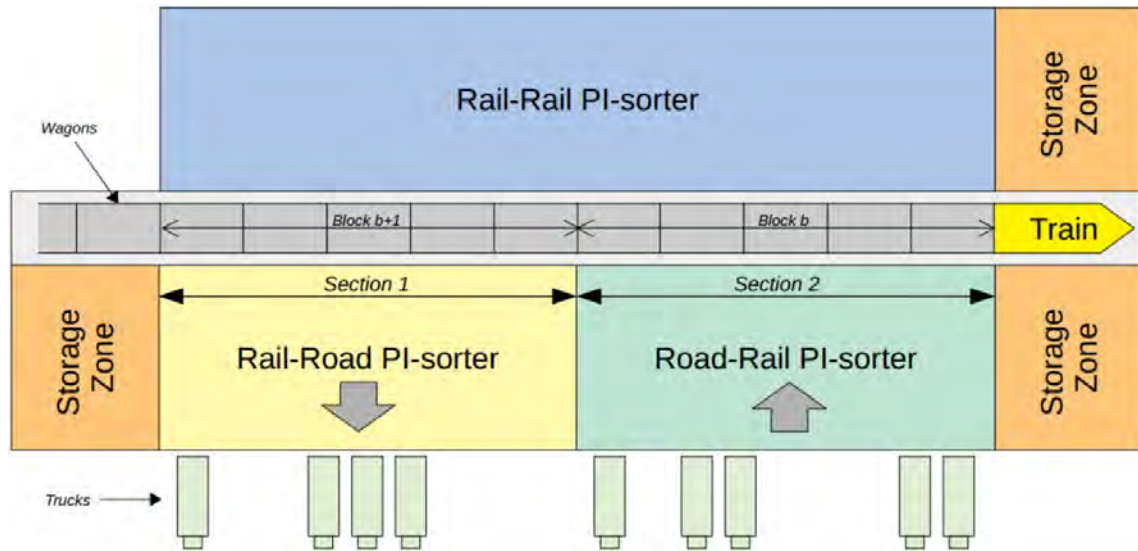

Figure 1: Overview of the Road-Rail PI-hub Layout

Once the train enters the Road-Rail PI-hub, the first block of five wagons is assigned to the Road-Rail PI-sorter section which is dedicated to receive PI-containers from trucks and load them into the train's wagons. PI-containers with the same destinations must be loaded in the same consecutive wagons so that in the next visited Road-Rail PI-hub the assignment of the outgoing trucks to the docks become easier since PI-containers with the same destination are grouped in consecutive wagons. Once the first block of wagons is filled with PI-containers, the next block will be assigned to the unloading Road-Rail section, until all the trucks are unloaded.

The main assumptions considered in this paper for the Road-Rail assignment problem are the following:

- Inbound trucks can unload containers with different lengths, and each one of those containers has a specific destination;
- PI-containers with the same destination must be loaded in consecutive wagons;
- Each one of the train's wagons must load only PI-containers that have the same destination;
- For simplification, one block of 5 wagons is considered for loading the PI-containers;

The lengths of PI-containers considered in this paper are: 1.2m, 2.4m, 3.6m, 4.8m, 6m and 12m. The useful length of the truck is 13.5m. The number of docks in the Road-Rail section is 28. For the wagons, the useful length is 18m (the full length of the wagon is 20m).

3 Mathematical formulation

In this section, the Road-Rail assignment problem is formulated as a mixed integer linear programming MILP model.

The mathematical model has two main decisions for the Road-Rail assignment problem:

- the assignment of the trucks to the docks;
- the assignment and the grouping of the PI-containers in the wagons.

3.1 Input parameters

N : total number of containers;

K : number of docks;

D : number of destinations;

W : number of wagons to load with PI-containers;

H : number of trucks;

Q : wagon's capacity (useful length);

i : indices of the containers;

k : indices of the docks;

d : indices of the destinations;

w : indices of the wagons;

h : indices of the trucks;

P_k : position of the center of the dock k starting from the right axis of the Road-Rail PI-sorter zone;

R_w : position of the center of the wagon w starting from the right axis of the Road-Rail PI-sorter zone;

L_i : length of container i ;

$$A_{hi} = \begin{cases} 1, & \text{if the container } i \text{ is in the truck } h \\ 0, & \text{Otherwise} \end{cases}$$

$$S_{di} = \begin{cases} 1, & \text{if } d \text{ is the destination of the container } i \\ 0, & \text{Otherwise} \end{cases}$$

α : weighting factor for the number of used wagons;

β : weighting factor for the total distance traveled by containers;

M : A big positive number, $M \geq \max(W, 5 * 20m)$.

3.2 Decision variables

Binary variables:

$$x_{iw} = \begin{cases} 1, & \text{if the container } i \text{ is assigned to the wagon } w \\ 0, & \text{Otherwise} \end{cases}$$

$$y_{hk} = \begin{cases} 1, & \text{if the truck } h \text{ is assigned to the dock } k \\ 0, & \text{Otherwise} \end{cases}$$

$$u_w = \begin{cases} 1, & \text{if the wagon } w \text{ is used} \\ 0, & \text{Otherwise} \end{cases}$$

$$z_{iwk} = \begin{cases} 1, & \text{if the container } i \text{ is in a truck that is assigned to the dock } k, \\ & \text{and the container } i \text{ is assigned to the wagon } w \\ 0, & \text{Otherwise} \end{cases}$$

$$e_{wd} = \begin{cases} 1, & \text{if } d \text{ is the destination of the wagon } w \\ 0, & \text{Otherwise} \end{cases}$$

Continuous variable:

d_{iw} : distance traveled by the container i to the wagon w ;

3.3 Objective function

The objective of the MILP model is to minimize the weighted sum of both the number of used wagons and the total internal traveled distance of PI-containers:

Minimize:

$$\alpha \sum_{w=1}^W u_w + \beta \sum_{i=1}^N \sum_{w=1}^W d_{iw} \quad (1)$$

Where α and β are the weighting factors for the number of used wagons and the total distance traveled by containers respectively.

3.4 Constraints

$$\sum_{w=1}^W x_{iw} = 1 \quad (\forall i = 1 \dots N) \quad (2)$$

$$\sum_{i=1}^N x_{iw} L_i \leq Q \quad (\forall w = 1 \dots W) \quad (3)$$

$$x_{iw} + x_{jw} \leq \sum_{d=1}^D S_{di} S_{dj} + 1 \quad (\forall i, j = 1 \dots N, \forall w = 1 \dots W, i \neq j) \quad (4)$$

$$\sum_{h=1}^H y_{hk} \leq 1 \quad (\forall k = 1 \dots K) \quad (5)$$

$$\sum_{k=1}^K y_{hk} = 1 \quad (\forall h = 1 \dots H) \quad (6)$$

$$x_{iw} \leq u_w \quad (\forall i = 1 \dots N, \forall w = 1 \dots W) \quad (7)$$

$$e_{wd} \leq S_{di} + 1 - x_{iw} \quad (\forall i = 1 \dots N, \forall w = 1 \dots W, \forall d = 1 \dots D) \quad (8)$$

$$u_w = \sum_{d=1}^D e_{wd} \quad (\forall w = 1 \dots W) \quad (9)$$

$$|w_1 - w_2| + 1 \leq \sum_{w=1}^W e_{wd} + M \left(2 - (e_{w_1d} + e_{w_2d}) \right) \quad (\forall d = 1 \dots D, \forall w_1, w_2 = 1 \dots W, w_1 \neq w_2) \quad (10)$$

$$|w_1 - w_2| + 1 \leq \sum_{w=1}^W u_w + M \left(2 - (u_{w_1} + u_{w_2}) \right) \quad (\forall w_1, w_2 = 1 \dots W, w_1 \neq w_2) \quad (11)$$

$$u_1 = 1 \quad (12)$$

$$d_{iw} \geq |P_k - R_w| - M (1 - z_{iwk}) \quad (\forall i = 1 \dots N, \forall w = 1 \dots W, \forall k = 1 \dots K, \forall h = 1 \dots H) \quad (13)$$

$$z_{iwk} A_{hi} \leq y_{hk} \quad (\forall i = 1 \dots N, \forall k = 1 \dots K, \forall h = 1 \dots H, \forall w = 1 \dots W) \quad (14)$$

$$\sum_{k=1}^K z_{iwk} = x_{iw} \quad (\forall i = 1 \dots N, \forall w = 1 \dots W) \quad (15)$$

$$x_{iw}, y_{hk}, u_w, z_{iwk}, e_{wd} \in \{0, 1\} \quad (\forall i = 1 \dots N, \forall w = 1 \dots W, \forall k = 1 \dots K, \forall h = 1 \dots H, \forall d = 1 \dots D) \quad (16)$$

$$d_{iw} \geq 0 \quad (\forall i = 1 \dots N, \forall w = 1 \dots W) \quad (17)$$

Assignment and capacity constraints:

In constraint (2), each container i unloaded from the truck must be assigned to only one wagon w . Constraint (3) ensures that the wagons capacity Q is not exceeded. Constraint (4) ensures that two containers i and j with different destinations cannot be loaded in the same wagon. In constraint (5), two trucks cannot be assigned to the same dock at the same time. Constraint (6) ensures that each truck is assigned to only one dock. In constraint (7), if a container is assigned to a wagon, this wagon is used. Constraint (8) sets the destination for a wagon if there is any container assigned to it. Constraint (9) ensures that if a wagon is used it must have a destination. In constraints (10), the wagons which have the same destination must be consecutive.

Constraint (11) ensures that all the used wagons must be consecutive in order to avoid empty wagons between the used ones (Figure 2). Constraint (12) ensures that the wagons are used starting from the first wagon.

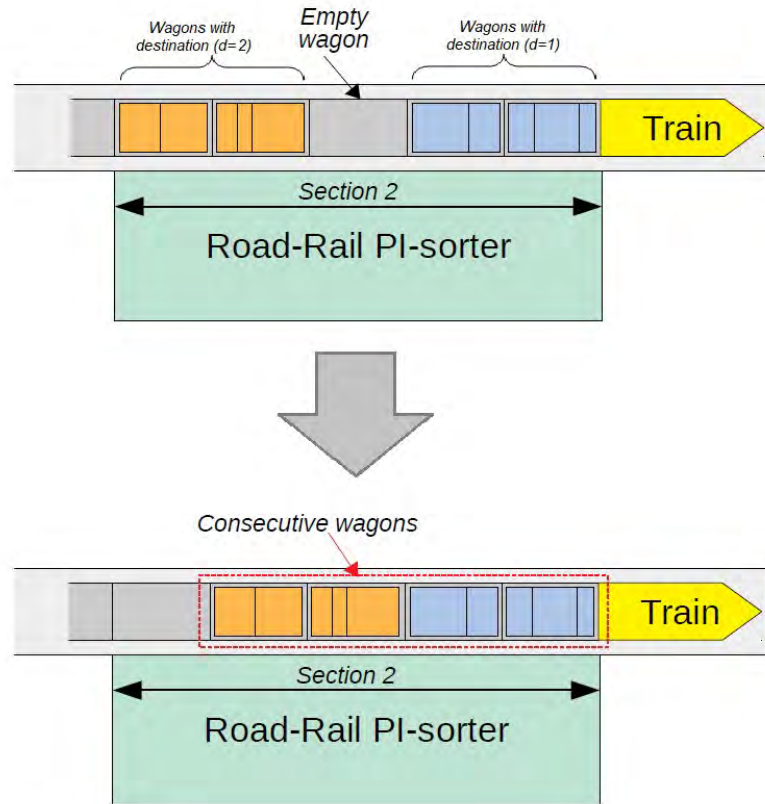

Figure 2: All the used wagons must be consecutive

Distance constraints:

Constraint (13) calculates the distance traveled by a container from the dock to the wagon. Constraints (14) and (15) calculate the value of the variable z_{iwk} which is used for calculating the distance in constraint (13). Constraint (16) ensures that the variables x_{iw} , y_{hk} , u_w , z_{iwk} and e_{wd} are binary. Constraint (17) ensures that the distance d_{iw} is positive.

The minimum value of the parameter M is:

$$M \geq \max(W, 5 * 20m)$$

Where W is the total number of wagons in the train, and $5*20m$ is the length of the road-rail section which can handle 5 wagons at a time (20m is the total length of one wagon and the useful length of the wagon is 18m). Indeed, in constraints (10) and (11) the minimum value of M is the total number of the wagons W . However, in constraint (13) the minimum value of M is the total length of the five wagons (length of the road-rail section).

4 Proposed approaches for solving the Road-Rail assignment problem

In this section, a tabu search meta-heuristic is proposed to solve the model. The solving process starts by assigning the containers to the wagons using the first fit bin packing algorithm of Johnson (1973) to generate an initial grouping of the containers. Then, the tabu search improves the grouping and finds all the possible combinations (Figure 3). The next step of the tabu search is to find the best assignment of the trucks to the docks while minimizing the number of used wagons and the distance travelled by the containers.

4.1 Initial grouping

In a first place, an initial grouping of the containers is generated based on the first fit bin packing algorithm (Johnson, 1973). After selecting a destination, each container with the selected destination is loaded in the first available wagon. Once the capacity of the wagon is exceeded, the next wagon is selected. The heuristic ends when the number of available wagons is reached.

4.2 Tabu search

The proposed tabu search is composed of three steps (Figure 4) :

- Improving the initial grouping of the first fit algorithm;
- Generating all the possible combinations of wagons of the initial grouping;
- Improving the trucks' assignment.

4.2.1 Improving the initial grouping of the first fit algorithm

The first step of the tabu search is to improve the initial grouping of the containers. At each iteration of this step, two local search moves are performed with different probability for each move ($P_1 + P_2 = 1$) :

- Insert container i in a different wagon with a probability P_1 .
- Swap container i with another container from a different wagon with a probability P_2 .

Those two local search moves are also considered in the third step while re-assigning the trucks to the docks.

4.2.2 Generating all the possible combinations of wagons

In the second step, the algorithm generates all the possible combinations of the best grouping found in the first step. For example as shown in figure 3, the blue containers with destination ($d = 1$) can be placed in different wagons on the train. It is important to mention that while changing containers positions, the wagons on which the containers with the same destination are placed must be kept consecutive (Figure 3).

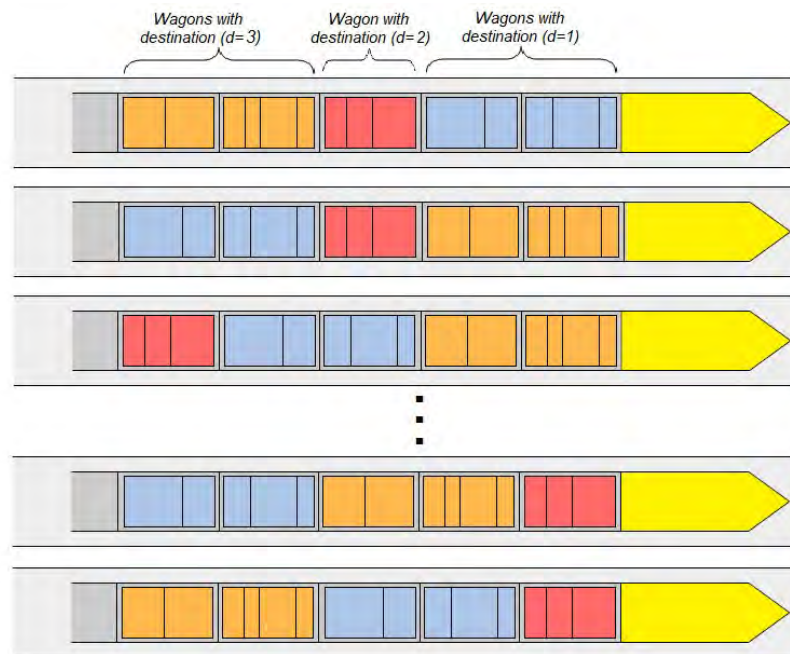

Figure 3: Example of grouping solutions generated in the second step of the tabu search

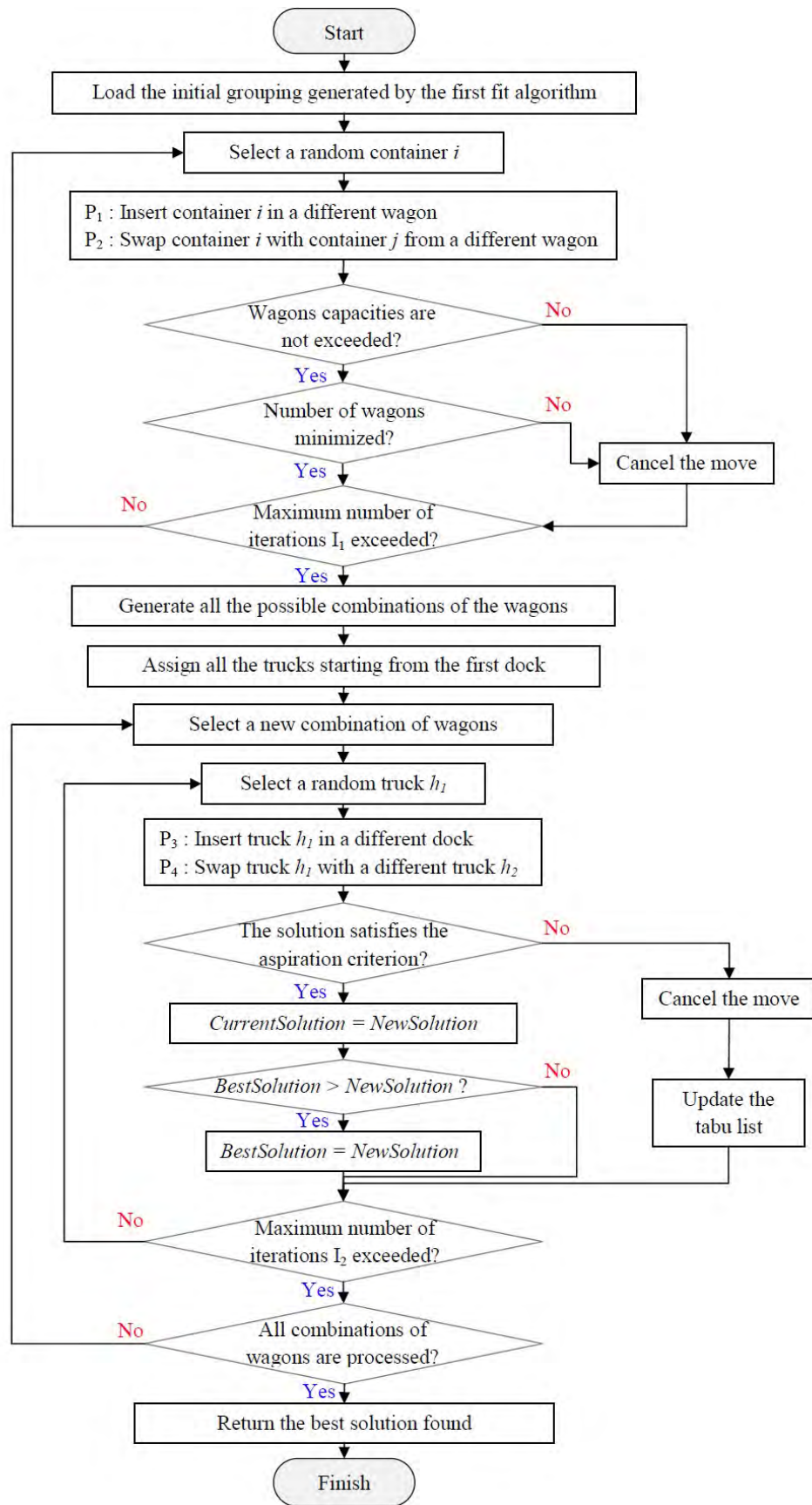

Figure 4: An overview of the tabu search meta-heuristic solving process

4.2.3 Improving the trucks' assignment

The last step is to improve the assignment of the trucks to the docks. For each combination of groupings, a random truck is selected. Then, the same local search moves of the first step are also used in the truck assignment with different probabilities ($P_3 + P_4 = 1$):

- Insert truck h in a different dock with a probability P_3 .
- Swap truck h with another truck from a different dock with a probability P_4 .

The next step is to check if the aspiration criterion is satisfied. In this study, the aspiration criterion, which is used to prevent the algorithm from getting stuck in local minima, is the deviation between the current best solution $S1$ and the new solution found $S2$.

$$A = \frac{\text{Objective}(S2) - \text{Objective}(S1)}{\text{Objective}(S1)}$$

If the deviation is lower than A , the move will be kept and the solution is accepted as the current solution. Otherwise, the move will be canceled and added to the tabu list. Afterwards, if the current solution is better than the best solution found, the current solution is considered as the current best solution found. An overview of the tabu search solving process is presented in figure 4.

4.2.4 Illustrative example

An illustrative example is detailed in table 1 which shows the containers that are initially loaded in the trucks with their different indices and destinations.

Table 1: Length and destination of the containers per each truck

Trucks	Containers lengths and (container's number, destination)						Total length
1	1.2 m (1, 1)	6 m (2, 2)	2.4 m (3, 1)	3.6 m (4, 2)			13.2 m
2	4.8 m (5, 1)	2.4 m (6, 2)	6 m (7, 1)				13.2 m
3	2.4 m (8, 1)	1.2 m (9, 2)	1.2 m (10, 3)	4.8 m (11, 1)	1.2 m (12, 2)	2.4 m (13, 3)	13.2 m
4	6 m (14, 1)	1.2 m (15, 1)	3.6 m (16, 1)	1.2 m (17, 2)	1.2 m (18, 3)		13.2 m
5	4.8 m (19, 2)	1.2 m (20, 1)	1.2 m (21, 2)	3.6 m (22, 2)	2.4 m (23, 1)		13.2 m
6	4.8 m (24, 2)	2.4 m (25, 2)	6 m (26, 3)				13.2 m
7	2.4 m (27, 2)	4.8 m (28, 3)	2.4 m (29, 3)	1.2 m (30, 2)			10.8 m
Total							90 m

The containers indices are presented for each wagon. As can be seen in figure 5, unlike the first fit based heuristic, the tabu search meta-heuristic is able to assign all the containers to the five wagons while respecting the capacity and the destination constraints.

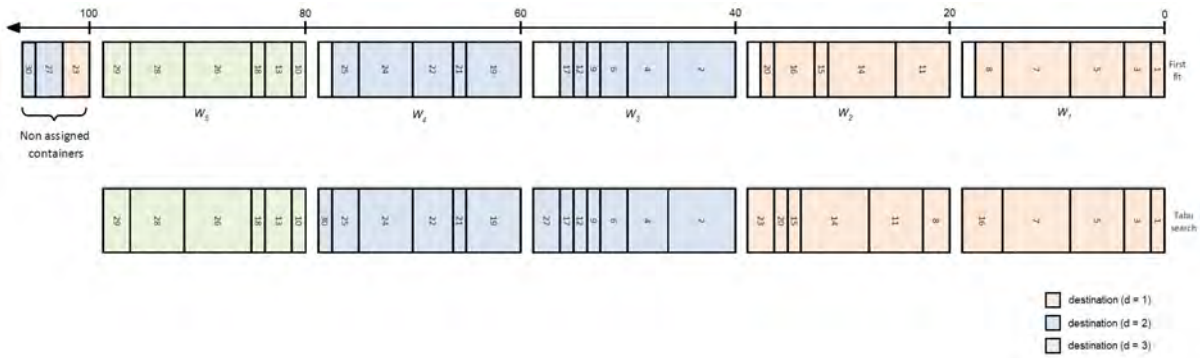

Figure 5: An illustrative example of the grouping of containers

5 Experimental results

The proposed mathematical model is validated on small instances using CPLEX Concert Technology which was able to find optimal solutions only for small instances (table 2). The first fit based heuristic and the tabu search meta-heuristic are implemented in C++. All the tests are performed on a PC Intel^(R) Core^(TM) i3 CPU 2.40 GHz with 4 GB of RAM. A maximum number of iterations without improvement is set for the first and the third step of the tabu search ($I_1 = 50000$ and $I_2 = 100000$). Indeed, if no improvement is found after this number of iterations, the algorithm stops, and the best solution found is returned. Those values are fixed after a tuning of parameters.

The tabu search is tested on several randomly generated instances. The total useful length of the 5 wagons is 90 m ($5 * 18 \text{ m} = 90 \text{ m}$). As described previously, wagons with the same destination must be consecutive. Moreover, a wagon cannot load containers with different destinations. The lengths of the containers are uniformly generated among the following values: $\{1.2\text{m}, 2.4\text{m}, 3.6\text{m}, 4.8\text{m}, 6\text{m}, 12\text{m}\}$. The obtained results are summarized in tables 2 and 3 (used wagons and the traveled distance of the containers).

Table 2: Comparing CPLEX and tabu search on small instances

N	D	H	CPLEX (Optimal)			Tabu Search			Distance Gap (%)
			Used Wagons	Distance	CPU Time (s)	Used Wagons	Distance	CPU Time (s)	
6	2	2	2	23.571	160.416	2	23.571	1.387	0.000%
		3	2	22.857	177.054	2	22.857	1.476	0.000%
	3	2	3	43.572	1220.394	3	43.572	2.707	0.000%
		3	3	42.143	819.489	3	42.143	3.650	0.000%
8	2	2	2	45.714	1094.823	2	46.427	2.177	1.560%
		3	2	64.285	3347.694	2	64.285	3.515	0.000%

Table 3: Results obtained with the tabu search on large instances

N	D	H	Used Wagons	Distance	CPU Time (s)
10	2	5	4	28.572	4.566
		8	4	51.429	6.899
	3	5	4	62.858	4.822
		8	4	47.142	7.107
15	2	7	5	36.782	7.733
		10	5	23.214	5.356
	3	7	5	51.784	8.514
		10	5	70.356	9.451

In table 2, CPLEX was able to find the optimal solution only for small instances. Tabu search found optimal solution for five small instances (table 2). Since CPLEX and tabu search used the same number of wagons, the gap between the distances is presented in the last column in table 2. For large instances in table 3, since no solution found by CPLEX within a time limit of 1 hour, only tabu search results are presented.

As it can be seen in tables 2 and 3, regarding the number of containers, while increasing the number of destinations the total distance travelled by the containers is also increased.

6 Conclusion

In this paper, a mixed integer linear programming MILP formulation of the Road-Rail assignment problem was proposed. The objective of the model was presented as a weighted sum of two objectives: the number of used wagons and the total travel distance by the PI-containers from the docks to the wagons. A first fit based heuristic and a tabu search meta-heuristic were suggested to solve the proposed MILP model. Finally, the proposed tabu search was tested on several instances and gave good quality results.

Future works will be conducted on optimizing the formulation of the proposed mathematical model to solve large instances. More tests will be conducted to test the robustness of the proposed methods on multiple instances.

7 Acknowledgements

The research work presented in this paper comes from the ELSAT2020 project of CPER sponsored by the French Ministry of Sciences, the Haut de France region and the FEDER.

References

- Johnson, D.S. (1973): *Near optimal bin packing algorithms*. Ph.D. thesis, Massachusetts Institute of Technology, Cambridge, Massachusetts.
- Meller R.D., Montreuil B., Thivierge C., Montreuil Z. (2012): *Functional Design of Physical Internet Facilities: A Road-Based Transit Center*, in Progress in Material Handling Research: MHIA, Charlotte, NC.
- Montreuil, B., Meller, R.D., Ballot, E. (2010): *Towards a physical internet: The impact on logistics facilities and material handling systems design and innovation*. Proceedings of the International Material Handling Research Colloquium (IMHRC), 1–23.
- Pach, C., Sallez, Y., Berger, T., Bonte, T., Trentesaux, D., Montreuil, B. (2014): *Routing management in physical internet crossdocking hubs: Study of grouping strategies for truck loading*. In: B. Grabot, B. Vallespir, S. Gomes, A. Bouras, D. Kiritsis (eds.) *Advances in Production Management Systems. Innovative and Knowledge-Based Production Management in a Global-Local World*, pp. 483–490. Springer Berlin Heidelberg, Berlin, Heidelberg.
- Sarraj R., Ballot E., Pan S., Montreuil B. (2014): *Analogies between internet network and logistics service networks: challenges involved in the interconnection*. *Journal of Intelligent Manufacturing* 25, 1207–1219.
- Treiblmaier H., Mirkovski K., Lowry P. B. (2016): *Conceptualizing the Physical Internet: Literature Review, Implications and Directions for Future Research*. 11th CSCMP Annual European Research Seminar. Vienna, Austria.
- Walha F., Bekrar A., Chaabane S., Loukil T. (2014): *A rail-road PI-hub allocation problems: model and heuristic*, Proceedings of 1st International Physical Internet Conference (IPIC 2014), Québec, Canada, 1-12.
- Walha F., Bekrar A., Chaabane S., Loukil T. (2016): *A rail-road PI-hub allocation problem: Active and reactive approaches*. *Computers in Industry* 81, 138–151.

Physical Internet: Stakeholder Mapping

Walid Mourhrib¹, Sahar Validi¹, Samir Dani¹
 1. University of Huddersfield, Huddersfield, UK
 Corresponding author: Walid.Mourhrib@hud.ac.uk

Abstract: *Current logistics paradigm has been practiced for decades. A new game changing logistic system named the Physical Internet (π) is proposed to shape the structure of supply chains. π aims to universally interconnect logistics networks in order to increase the efficiency and sustainability of logistics processes. However, this development requires the participation of different key logistics players. Different players, including researchers from academia, industry and government, have made contributions towards the challenging task of π realisation. ETP-Alice (or Alice) stands for European Technology Platform - Alliance for Logistics Innovation through Collaboration in Europe, is a European initiative set up to develop a comprehensive strategic roadmap for the adoption of the Physical Internet. However, the effective adoption of this system requires, partially but fundamentally, a consensus by all π stakeholders on the credibility of the big picture this system is proposing, which is the optimisation of the overall logistics practice.*

In this paper, the purpose is to conduct a stakeholders mapping of the Physical Internet using systems thinking approach, analyse role and motivations of each stakeholder, and present a rich picture of π stockholders. The rich picture will help build synergies between policy makers and industry with the main aim of adopting π and encourage more researchers, logistics practitioners and policy makers to join the game.

Keywords: *Physical Internet (π), Stakeholders, Soft Systems Methodology, Systems Thinking.*

1 Introduction

The practice of logistics has evolved continually to involve more strategic orientated decisions. In fact, logistics key players have been adopting systems approach throughout the development of the domain to make operational and strategic decisions (Ballou, 2007). The evolvement of logistics is due to changes in customers' needs and wants alongside an advancement in technology. Nowadays, e-commerce has radically contributed to structural change in logistics practice. Examples of technologies include constant tracking of deliveries, delivery drones, etc. Changes at individual level led to structural changes at freight logistics level. One latest technology named the Physical Internet (π) involves a new logistics paradigm that aims to shape the structure of conventional logistics practice at the global level. This article will adopt the symbol (π) to refer to the Physical Internet as it was used in 28 references about Physical Internet such as (Montreuil, 2009; Sarraj et al., 2014; Sternberg & Norrman, 2017). The Physical Internet is a holistic metaphorical concept based on the realisation of the Digital Internet. Physical Internet (π) is "a global logistics system based on the interconnection of logistics networks by standardised set of collaboration protocols, modular containers and smart interfaces for increased efficiency and sustainability." (Ballot et al., 2014, loc. 555).

However, the participation of key logistics players is required for a successful implementation of the Physical Internet. In the domain of logistics, these key players are called stakeholders that are responsible of strategic decisions in development of logistics. There are many definitions of 'stakeholder' as they differ across discipline. For the following study, a common definition is adopted as it fits the domain of π as well, "A stakeholder is an individual or group influenced by — and with an ability to significantly impact (either directly or indirectly) — the topical area of interest" (Engi & Glick, 1995, p. 11).

The aim of the Physical Internet is the optimisation of the global logistics process. For an effective implementation of this system a consensus by all π stakeholders is, partially but fundamentally, required on the credibility of the big picture this system is proposing. This article aims at mapping the stakeholders of the Physical Internet using Soft Systems methodology in order to reach a consensus. The following section two reviews and analyses the relevant literature. Section three provides an overview of the approach adopted by this study to map the stakeholders while section four looks at the adopted methodology and analyses the results. Finally, a discussion is provided in section five before a conclusion section highlights suggested future research.

2 π Stakeholders: Review of Literature

Physical Internet's notion and its proposed system revolutionises the foundation of logistics paradigm. This new paradigm reforms the idea of ownership in logistics processes to collaboratively managing logistics services within a shared network (Ballot et al., 2014). This notion of shared network will potentially rise conflicts of interest between the stakeholders involved in the system (Cimon, 2014). This section of the paper reviews the available literature on the potential stakeholders of π , the drivers and contributions stakeholder, and most importantly investigates their views on the Physical Internet system.

Two main stakeholders are involved in the transshipment of an object from origin to destination; the shipper and the receiver in the logistics systems. A common classification of freight logistics stakeholders composes of *providers*, *users*, *enablers* and *legislators* (Abdoulkadre et al., 2014; Crainic & Montreuil, 2016).

Providers are defined as “companies where the main business is the provision of transport and logistics services” (Sanchez-Rodrigues et al., 2010, p. 51). They consist of third-party logistics providers, storage facilities as well as terminals. *Users* are made up of retailers, manufacturers, distributors and shippers; beneficiaries that exploit the system via the support of enablers. A main *User* is a private customer or business who is expecting to receive object from different shippers. However, it could be a manufacturer or a shipper who sends objects to a wide range of customers especially in case when they outsource service providers. *Enablers* are defined as “a company that provides technology or consultancy to facilitate the movements of goods.” (Sanchez-Rodrigues et al., 2010, p. 51). They comprise of freight forwarders and brokers (or else known as carriers) acting as intermediators between sender and receiver. Lastly, *legislators* represent in general those who set the regulations and policies (Crainic & Montreuil, 2016).

The same classification of freight logistics stockholders can be applied to the Physical Internet system. In fact, the implementation of π system will occur on an existing logistics system, which makes this implementation more of a strategic challenge rather than operational. Crainic and Montreuil (2016) describe the relationship between stakeholders in interconnected city logistics. In terms of business, they suggest a contractual agreement is required between users and providers, whereas authorities are required to facilitate an environment compatible and appropriate in terms of regulations.

While most of the publications about π combine *enablers*, *users* and *providers* in one category; industry stakeholders (Abodohoui et al., 2014), π *legislators* are referred to in literature as governance. However, this last section about governance is still underdeveloped. Only one paper discussed the need for governance and its design in π (Cimon, 2014). The need for involving governance is essential to the monitoring and regulations enforcement in the Physical Internet. Hence, governance is referred to as regulatory authorities and policy makers same existing in the Digital Internet. In a bigger scale, Weber (2013) refer to Internet of Things (IoT) governance as “design of institutions and the structure of authority to allocate resources and coordinate or control activities in the society.” (p. 341). This could be adopted in the

understanding of π governance. Following literature, ETP-Alice has been the first supranational body to urge for building frameworks and models for π governance. (Alice, 2014). However, it is only responsible for the strategic implementation of π and not the governance.

According to Alice (2015), the strategic implementation of π is followed by different drivers offered to industry stakeholders for a proper collaborative coordination between them. These drivers include efficiently increasing the service level of products to customers and lowering barriers for customers to enter new markets with access to new products. The contributions and incentives of π stakeholders has been discussed also in a more recent report by Alice (2017b). The incentives of industry stakeholders to reach a truly sustainable, efficient and interconnected logistics system appear mostly in the reduction of all types of costs and increase value added to customers. Meanwhile, contributions by only European Technology Platforms (ETP), which fall in the category of governance, have been discussed highlighting therefore a discussion gap in contributions of industry stakeholders in this report.

Different discussions have carried out about industry stakeholders in which they appeared to be the most important amongst all stakeholder. Enablers and providers of transport systems are the most important industry stakeholder because their contributions matter the most to the implementation of π . However, this implementation is likely to be difficult due to the nature of their business models, which tend to be private and not supporting collaboration with other peer stakeholders. “Some stakeholders, such as shippers and logistics service providers, are likely to defend their business models and their ability to maintain control over their propriety networks” (Iacovou et al., 1995; as cited in Sternberg & Norrman, 2017, p. 13). Thus, collaboratively sharing a network might be considered a threat to their profitable business models. Thus, open discussion is essential to clarify the role and incentives of each stakeholder. Most publications of Π stakeholders are conducted within the industry as opposed to governance. Majority of them discuss the design of business models and their requirements, so they are applied to industry stakeholders. Other publications bring out a discussion about π stakeholders regardless of their different cores. However, Sternberg and Norrman (2017) stated that most of π publications assume that commercial stakeholders will act rationally in the favour of themselves or follow a central optimisation that would benefit their rivals. This is important since most of industry stakeholders tend to be commercial. Therefore, a flow of π stakeholders’ categorisation will contribute to the holistic view of stakeholders’ analysis.

Furthermore, legislators play a major role as the implementation of π . Alice (2017a) is a sponsored European Technology Platform initiative. ETP-Alice has suggested a roadmap for implementing π within the next thirty years’ times. The roadmap is broken down into achievable milestones. Alice (2017a) assumes that π is desirable enough for an easy systematic implementation. Shaposhnikova (2017), in a recent interview with Alice vice chair, explains the bottom up approach adopted by Alice to realise π . Based on this study’s analysis, it is concluded from the interview that Alice vice chair suggests that the implementation of π should start at grassroots level. Knowing that innovative technology already exists, the focus should be on changing the mind-set of firms towards more collaboration (Shaposhnikova, 2017). In an earlier work, Xu (2013) argued that implementation of horizontal logistics collaboration is challenging due to the lack of a feasible collaboration mechanism. This clarify the importance of the bottom up proposed by Alice. Figure 1 shows how Alice anticipates the realisation of π .

Hence, it is the main role of legislators to convince industry stakeholders in order to follow a central optimisation approach, giving the early stages of the roadmap. Nevertheless, this plan will encounter difficulties, as companies tend to have different opinions about π system. Sternberg and Norrman (2017) highlights difference viewpoints of stockholders; some look at π as a vision of all existing technologies as opposed to a blueprint, which tends to be the view of Alice. A group of researchers (e.g: Ballot et al., 2013; Russell D. Meller et al., 2012; Montreuil et al., 2012c) look at π as an engineering system. This highlights a misconception

between stakeholders, which could delay the implementation of π if stakeholders are not brought together in a united mind-set.

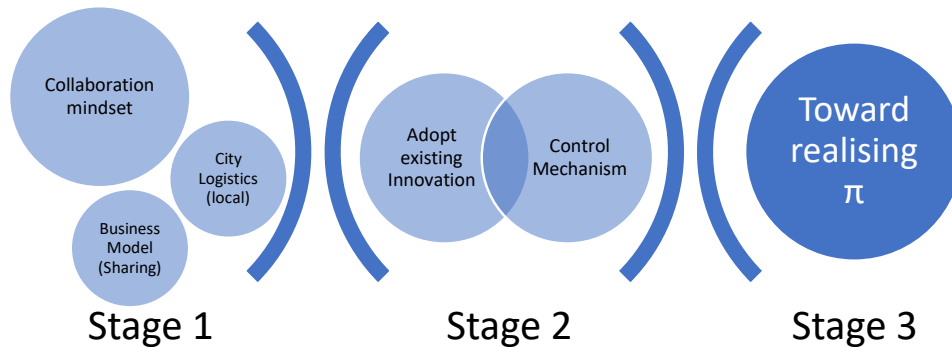

Figure 1: Adoption of PI (Source: Shaposhnikova, 2017)

Conflicts might also arise within π if implemented. Several papers shed the light on principal-agent issues representing the conflicts between stakeholders (Cimon, 2014; Treiblmaier et al., 2016). In order to maintain best practice of the Physical Internet, issues involving variety of stakeholders have to be further investigated beyond the adoption of business models. Although business models should generate revenues to different stakeholders (Montreuil, 2011), conflict sources come from the decentralisation, flexibility and open source nature of π system (Cimon, 2014).

Academia represents another category of stakeholders that has been discussed in literature, notably the need for their collaboration with industry and government is highlighted (Montreuil, 2011). The combination of three categories of stakeholders is usually pointed out in literature. A special issue “*Physical Internet and interconnected logistics services: research and applications*” belongs to well ranked journal has been introduced in order to partially provide researchers and practitioners with a review of π state of art and methodologies (Pan et al., 2017). Sternberg and Norrman (2017) aims at guiding researchers and policy makers with their future efforts in π . As research about the Physical Internet is at its early stages, researchers should be important contributors to the increasing transdisciplinary attention about the subject. In fact, Physical Internet was first inspired by a group of researchers that investigated the possibility of adopting the metaphor from the Digital Internet (Montreuil, 2011).

Different categories of stakeholders have been discussed in the literature. The classification of π stakeholders is essential to the analysis of π system because it eases the confusion of the labelling between actors and customer in the system of π . Figure 2 provide a summary of all stakeholders, examples, to what category they belong to, and their viewpoints on π . Moreover, the contributions and the incentives are still underdeveloped for some of them. For example, the impact of academia as a major stakeholder in the literature is still unclear to some extent.

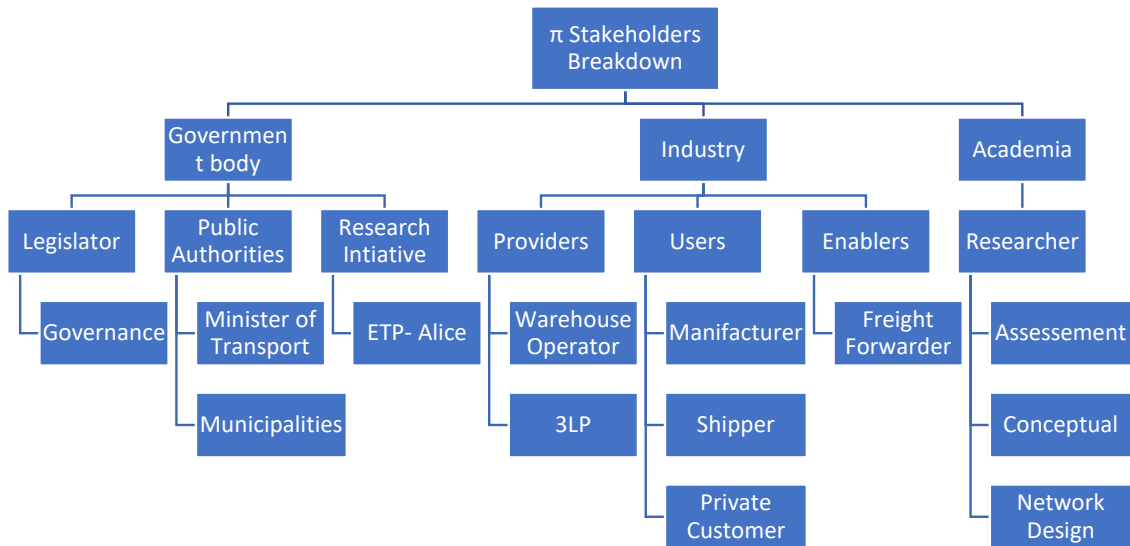

Figure 2: Breakdown of Π Community

All stakeholders acquire different views on π while some share more than one view. Most importantly, the viewpoints do not depend on the stakeholder or their specific category. Differences in views may differ within examples of same stakeholder with same category. Figure 3 highlights most important worldviews on π , extracted from an analysis of an extensive review of literature.

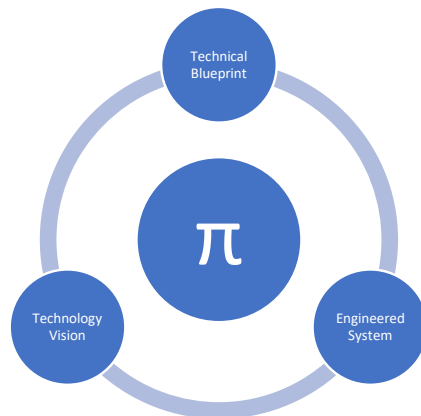

Figure 3: Worldviews on the Physical Internet

These stakeholders are lacking an agreement between them since the variety of worldviews differ across them. In fact, disagreements between stakeholders occurs depending on to what extent they believe π is likely to be successfully implemented in the near future. In the rest of this article, the objective is to map stakeholders in a way that a potential consensus on the Physical Internet can be made possible. Therefore, a holistic view of stakeholders' analysis when categorising them is required, as it is currently lacking. In order for that to happen, a

normative approach to stakeholders' analysis and soft systems methodology (SSM) are adopted.

3 Stakeholders Analysis: Systems Thinking Approach

A system consists of elements, purpose and interconnections. There are many examples of systems that are part of daily practice tend to be taken for granted such as a car. According to Arnold and Wade (2015), a 'system test' can be run in order to justify the credibility of the system. Figure 4 shows the main components needed for to test the credibility of a system. Looking at the definition adopted of the Physical Internet, it checks all boxes of the system test.

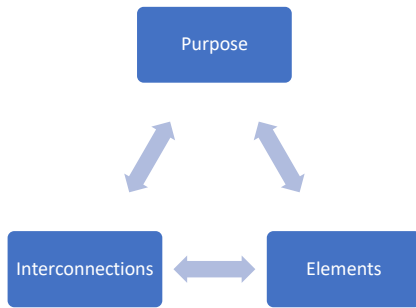

Figure 4: System Test

Looking into the engineered system view, the definition of the Physical Internet succeeds actually to define π as a system. In a systems context, elements of a system may also consist of 'actors' and 'customers' which play this role of transforming input into output. In the Physical Internet, similar principle is taking place despite the change in structure. However, these stakeholders may be seen from different angles, belonging to different π subsystem. In π transit centre for example, customers are the shippers and transportation service providers as opposed to π transit owners and operators, which play the role of actors. Oktai et al. (2014) state that these two key sets of stakeholders acquire well-defined expectations and goals. Thus, they design a business model that deploys best of the Physical Internet by these sets of stakeholders.

On the other hand, this analysis assumes that the main elements of the system are stakeholders and their views represent the interconnection while the purpose is to accommodate a consensus on π . Nevertheless, their views tend to differ as it has been concluded from literature. This creates a disagreement between stakeholders on whether π is actually a system or not. This paper adopts a normative approach, discussed in Reed *et al.* (2009), in order to solve this issue of disagreement. A normative approach "features stakeholders who recognise that they face a common problem which cannot be solved by 'hard system thinking', and subsequently negotiate their conflicting goals and different perspectives in order to agree collectively on action. (Checkland, 1999; as cited in Reed et al., 2009, p. 1935). Soft Systems methodology is an efficient way to demonstrate a clear understanding to the issue of disagreements based on systems approach.

4 Soft Systems Methodology (SSM)

The SSM methodology was first developed by Peter Checkland in 1960 in Lancaster University as a substitute to hard systems approach. SSM works efficiently in solving organisational issues that are characterised by a variety of subjective views. According to Burge (2015), hard systems approach fails to solve issues, which usually come with subjective views. One important tool introduced by SSM is CATWOE (*Customer, Actor, Transformation, Weltanschauung, Owner, and Environment*) that exists to support building complete root definitions depending on worldviews; known as 'Weltanschauung' in CATWOE. On the other hand, a rich picture aims

at presenting general overview of how all actors -stakeholders in this case- interpret the system. Then, the purpose of relevant activity models is to allow a system thinking approach to analyse the situation. According to Platt and Warwick (1995), the purpose of CATWOE is to support building complete root definitions of the relevant system(s) selected in the rich picture.

According to Checkland (1999), there are four main steps to perform soft systems methodology. SSM is adopted to highlight the process of dealing with world situations while applying systems thinking.

The main steps are:

1. "Finding out about the problem situation, including culturally and politically
2. Formulating relevant and purposeful activity models
3. Debating the situation using the models seeking from the debate:
 - a. Changes, which could improve the situation and are regarded as both desirable and (culturally) feasible
 - b. The accommodation between conflicting interests which will enable action-to improve to be taken
4. Take action to bring about the improvement"

Indeed, step one talks about building a rich picture, performing CATWOE and concluding root definitions. Step two initially analyse the situation problem found in rich picture at systems thinking level. Later in step three, SSM uses actors' worldviews to assemble a debate about desirable and feasible changes. The next step involves discussing feasible and desirable changes in order for consensus between all π stakeholders. This leads to taking action (step 4) to improve the situation following suggestions concluded from the analysis.

In this research, it is assumed that all stakeholders are following a central optimisation approach and therefore are open for discussion. After their willingness to collaborate, they tend to disagree on the way they believe in the Physical Internet. Therefore, SSM is there to accommodate their worldviews.

4.1 Stakeholders Rich Picture Mapping

The rich picture represents an overview of how stakeholders interact with each other via their views on the Physical Internet both before the implementation and hypothetically if the system was implemented. The interactions between the stakeholders is a key factor in determining the type of relationship a stakeholder should have with π . Their views tend to depend also on how the system is advantageous to them. For example, providers tend to have more of direct relationship with the system than users.

The aim of the rich picture is to express the unstructured situation of how π is perceived among different stakeholders. In SSM, rich picture is essentially related to the stage 'finding out about' the situation addressed and expressing its results in a way that advocate an overview of the complexity of the situation and its existing relationships (Patching, 1990). In this study, the complex relationships represent the unclear mixture of π views between stakeholders. Results are concluded from data extracted from literature, and the problem situation is no longer unstructured and well expressed.

As seen from the Figure above, the rich picture highlights all connections within the system. This is important to the understanding of the current situation. "The rich picture aids the understanding so what is available to aid the selection" of relevant systems. (Wilson, 2001, p. 42). It highlights the main view, which tend to be technology vision among logistics key industry players. In order to enrich the founding of rich picture analysis in terms of relationships between stakeholders, this study suggests adopting a tool named stakeholder matrix analysis in addition

to SSM. This technique will provide a more about understanding about stakeholders' contributions on π .

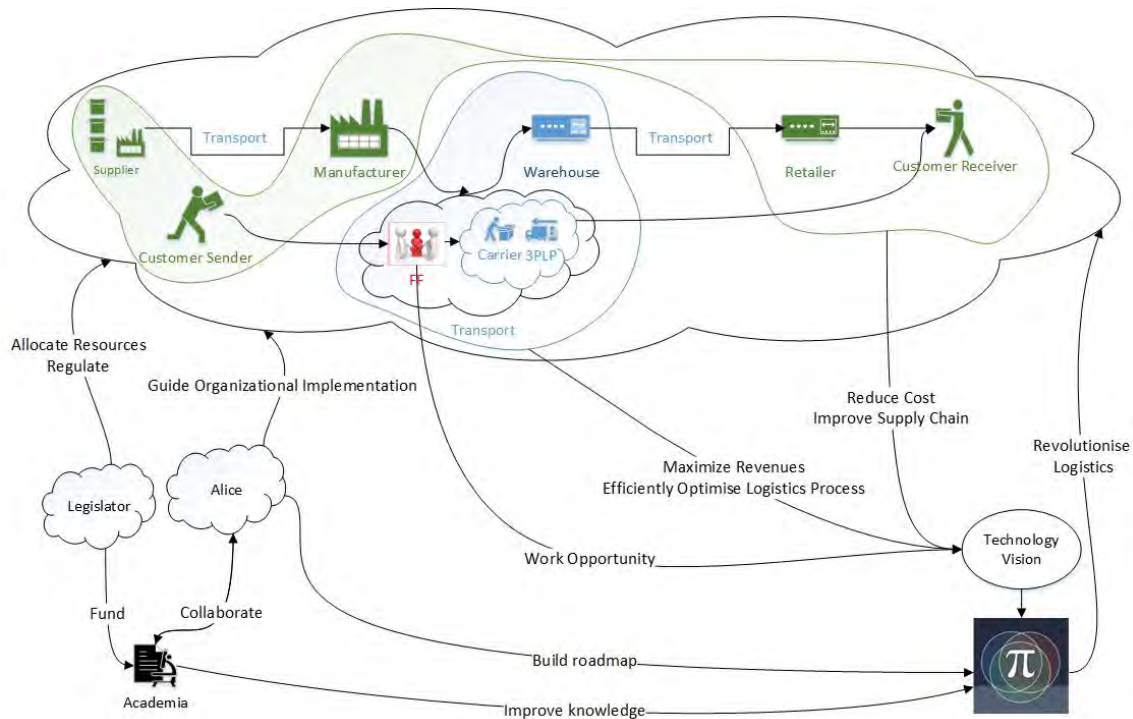

Figure 5: Stakeholders Rich Picture

4.2 Stakeholders Matrix Analysis

This section tries to analysis the contributions and incentives of each stakeholder. In Figure 2, the breakdown suggested that four main stakeholders are involved directly with π , *provider*, *enabler*, *user* and *legislator*. Following π literature, 77 articles strictly related to π have been extracted before conducting a content analysis in order to highlight the importance of each stakeholder. This excludes for example papers about sustainability or Internet of Things.

4.2.1 Word Count Analysis

The first indicator relates to the number of papers each stakeholder is stated. The second one indicates the frequency by how much the term is repeated in literature. Because *legislator* is directly related to governance as this study suggest, the word count of this later is calculated for both governance and *legislator*.

First, results in Figure 6 show that *provider* is taking the lead on both diagrams followed by *user*, *legislator*, then *enabler*. This suggests that logistics providers are crucial to the implementation of π while users would be more essential to the outcomes of π , meaning after the implementation.

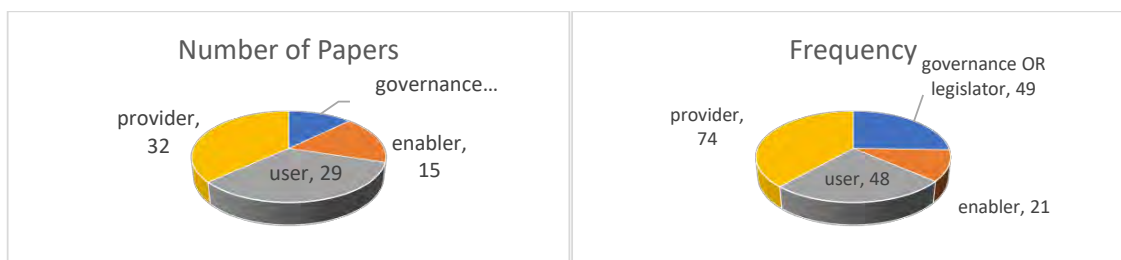

Figure 6: Stakeholders Word Count Analysis

However, the small number of papers relating to *enabler* and *legislator* suggests that this section is not well developed as literature agrees especially on governance (Sternberg & Norrman, 2017). Also, enablers tend to be less stated in the literature although they play a major role to the implementation of π as opposed to conventional logistics given the technology embedded in π .

4.2.2 Content Analysis

This section takes the analysis to a further level by investigating each stakeholder term by itself within literature. First, a percentage coverage is calculated of each term within all 77 articles using Nvivo software. Taking the average percentage of characters coded and page area, this indicator is supposed to provide an enriched results compared to number of word count. Figure 7 present an overview of top five most coded source of each stakeholder term based on the percentage coverage. Results showed that almost all top five most covered articles with the four π stakeholders in their contents belong to either a decent rated journal or well-known conferences. For example, McFarlane et al. (2016) is most coded article (in terms of % coverage) with term '*provider*', and it belongs to a three star journal. This highlights the importance of *provider* in the domain of Physical Internet. On the other hand, *legislator* (or governance) is mostly covered in Alice's reports and IPIC Conferences (i.e., Abdoukadre et al., 2014; Alice, 2014, 2016; Cimon, 2014). Hence, a highlighted interest is limited to only European governments bodies and initiatives as literature suggest. Users tend to be less covered in terms of content compared to others although their importance to the outcome of π . However, this can be explained by tendency of publications to be covering more content related to the adoption of π since it is it yet realised. Results about *enabler* should confirm the finding form Figure 6 which highlights the lack of literature about π enablers.

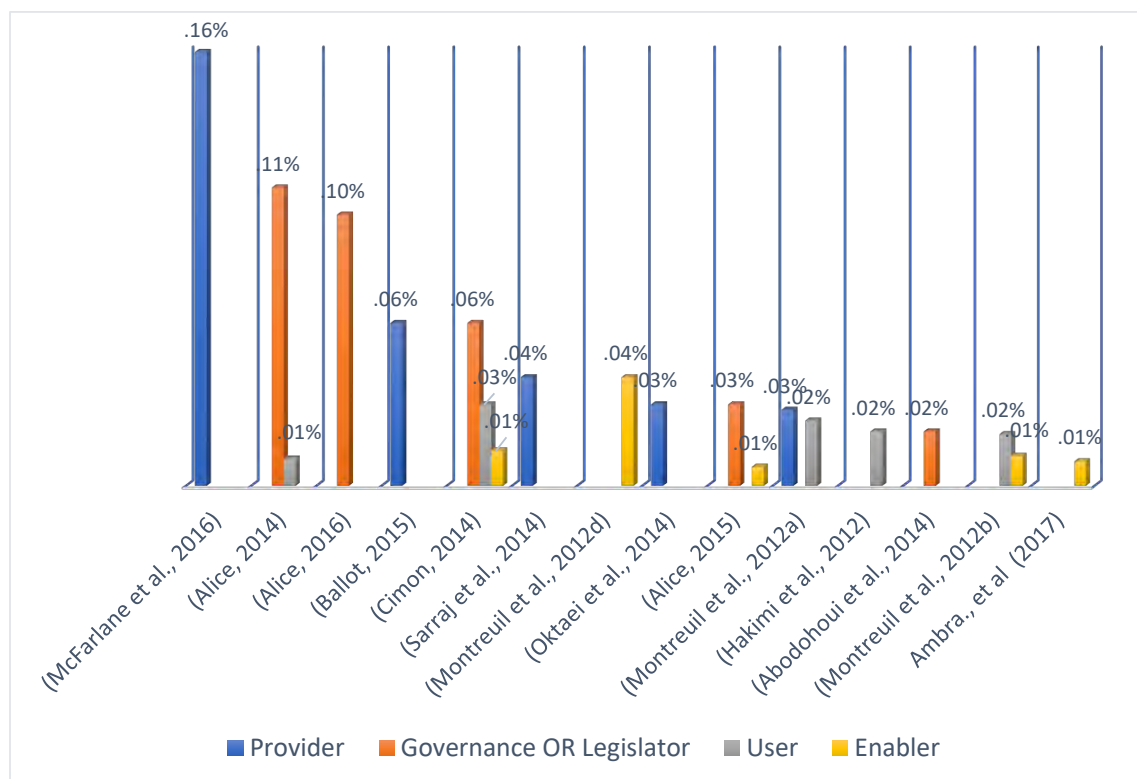

Figure 7: II Stakeholders Content Analysis

Consequently, it should now be easy to showcase the interest and the influence of each stakeholder given the two previous analysis. This study chose to assign world count results to

interest/ contribution and content analysis to size of the stakeholder. Interest will represent the word count while contribution the frequency. Size of the stakeholder is calculated by averaging the percentage coverage of the top 5 counted sources concluded in the previous part. Following this approach, a stakeholder matrix adopted from Mendelow (1981) is scratched to better visualise this findings. Figure 8 represents stakeholder matrix analysis which aims at building an understanding of the impact of stakeholders.

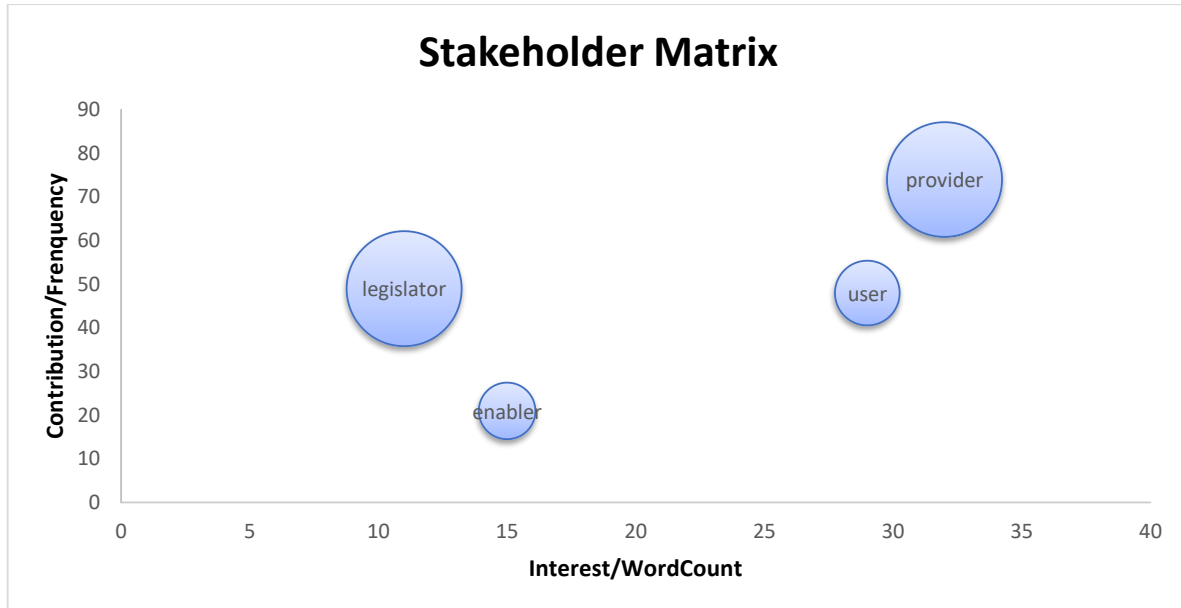

Figure 8: II Stakeholder Matrix (Adapted from Mendelow, 1981)

It is concluded in an early debate within literature that legislators and providers tend to be the most influencing stakeholders. This recent result confirms that with more importance to providers. However, users proved to be less contributing but more influential given their interest in the outcome of π and the implementation. Providing the assumption that users should be big in size and also contribute to the π , it should be brought to attention that this is finding is a result of literature which tend to be under development and working progress. The same goes with enablers who proved to be low with all indicators.

4.3 Modelling views

The Rich picture provides a mechanism to facilitate the process of conceptually modelling relevant systems (views in this case). The idea is to develop a conceptual analysis with systems thinking approach about the problematic expressed in the rich picture. The aim is come up with solutions to what been expressed as a problematic rich picture. Two methods working together have been adopted. The analysis starts by extracting the views from the rich picture which have been briefly summarised form literature. Later, it is suggested to adopt a CATWOE technique to provide a clear understanding of these views.

4.3.1 Three root definitions

In the early stages of applying system thinking, the root definitions are meant to provide how stakeholders look at π as a system. Root definition is also used to come up with a unified view of what stakeholders want to achieve (Houghton, 2013). In the case of this study, the use of root of definition is more conducted in producing views of relevant systems as opposed to the view leading the rich picture. The rich picture is supposed to provide the unified view of π . Hence, CATWOE, another SSM tool, is used along the rich picture building. The main objective of this tool is to support building complete root definitions of the relevant systems

selected in the rich picture. (Platt & Warwick, 1995). The following Table highlights the different components of CATWOE in the determination of the root definition of the Physical Internet along with at least one evidence from literature. Components of CATWOE have been discussed on almost all literature. However, this Table tries to state most relevant examples where each component has been directly discussed.

Table 1: CATWOE Analysis of Physical Internet based on Literature Review

C	Who is the beneficiary of service provided by π ?	Receiver/Beneficiary Supplier/Manufacturer	(Hakimi et al., 2012)
A	Who is performing activities from service provided by π ?	Shippers/3LSP Freight Forwarders Transportation Services/ Drivers	(Crainic & Montreuil, 2016; Qiao et al., 2016)
T	What is the main processes of π ?	Packaging/Encapsulation/ Consolidation Routing/Shipment Last mile delivery	(Modulushca, 2015; Sallez et al., 2016) (Sallez et al., 2015) (Crainic & Montreuil, 2016)
W	What is the global meaning of π ?	<ul style="list-style-type: none"> • Vision of existing technology • Technological Blueprint • Engineering system 	<ul style="list-style-type: none"> • (Montreuil, 2011) • (Alice, 2017a) • (Ballot et al., 2014)
O	Who is responsible of regulating π ?	Legislator Public authority	(Abodohoui et al., 2014; Cimon, 2014; European Commission, 2013)
E	What are the environmental constraints?	Three pillars of Sustainability	(Russell D Meller et al., 2012; Montreuil, 2011)

The conclusion drawn from this analysis reveals that stakeholders share same information about, *Customer*, *Actor*, *Transformation*, *Owner*, and *Environment* in CATWOE acronym. However, the *Worldview* differs among stakeholders. This has been concluded after a critical analysis of the literature review and an assumption stating that π would be perceived differently depending on the viewpoint. Patching (1990) explains *Worldview* as “how system is perceived from a particular (explicit) viewpoint – sometimes described as ‘assumptions made about system’”. (p. 74)

It is found that some of the elements of the Physical Internet are well defined in literature and share a consensus between stakeholders. This include the technical definition which mainly focus on the main process of π that transforms an input to an output. Regulations are discussed in only few articles highlighting the need for π governance and legislators. The environment that could influence, but don't control the system would include the three pillars of sustainability. This later is agreeably discussed in literature notably in definition of π to be the main constrain of the system. Concerning *Customer* and *Actor*, Crainic and Montreuil (2016) adopted a classification of freight logistics to apply in the domain of the Physical Internet. *Users* have been identified as the beneficiaries (*Customer*) of π while *providers* are considered the main *actors* performing the main process of π .

As of the *Worldview*, the analysis from π literature suggests that stakeholders do not share same view about the Physical internet. In fact, stakeholders' views differ depending to what extend they appreciate the potential change of π from vision into reality. Hence, the following three

root definitions have been concluded in a way the three views are distinguished between each other.

RD1: Π is a vision of existing technology, which involves efficiently transporting objects by satisfying customers' needs and optimizing the logistics process

RD2: Π is a technological blueprint, which requires a strategic roadmap as well as control mechanism in order to take place. Given its positive effects, π tend to be desirable by stakeholders

RD3: Π is an engineering system, which is based on the interconnection of logistics networks following standard protocols, encapsulation of objects, and smart interfaces to enable an efficient and sustainable logistics.

4.3.2 Soft systems models

The purpose of the soft model is to demonstrate the situation at system thinking level. The same Figure 3 has been used to demonstrate the use of soft systems model. It is concluded that views can only be accommodated by a circular flow of information. The outcome will ensure to some extent collaboration between academia and industry, organizational readiness, and conceptual awareness.

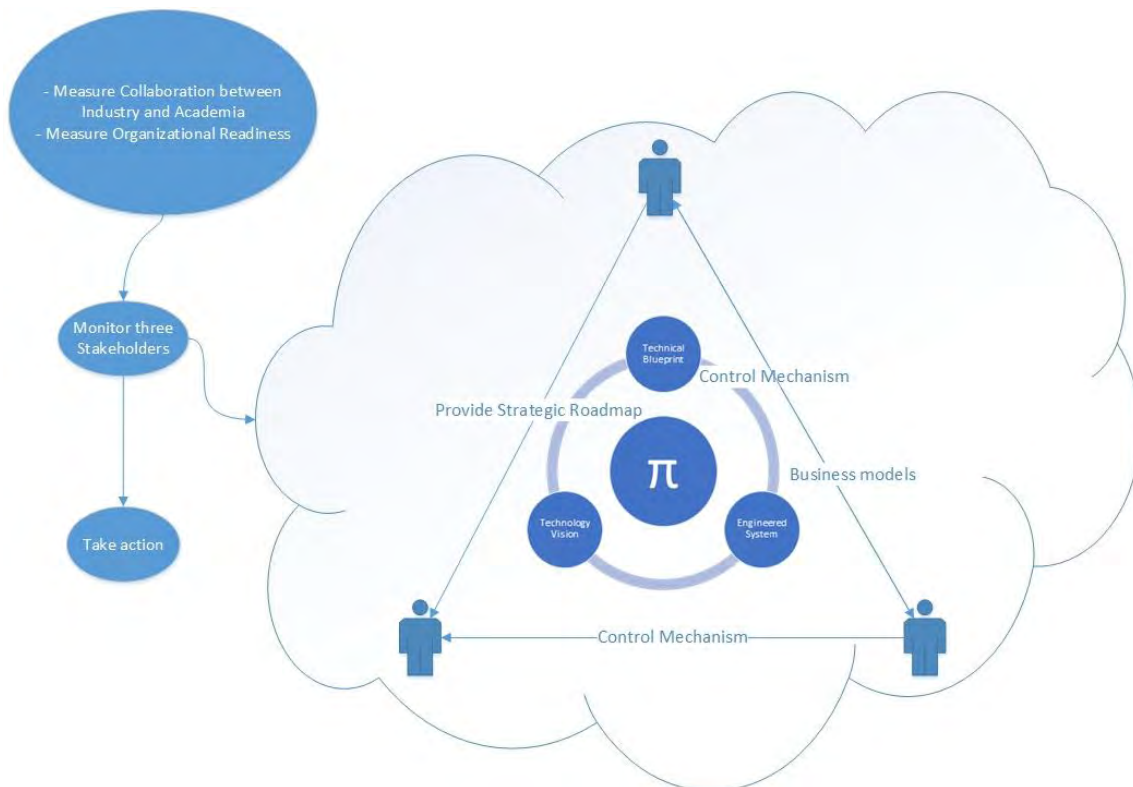

Figure 9: Soft System Model for Physical Internet Stakeholders

5 Discussion

ETP-Alice announced the ultimate goal of π is globally shape the future of logistics which leads to misconception of whether π exist or not (Treiblmaier et al., 2016). This gives a reasoning to the three views available in literature. It is concluded then that all the three views are credible. However, they witness in a sequence of change alongside the adoption. To elaborate, viewing π as a technology vision will at some point be seen as a blueprint and later an engineered system.

At the moment, views tend to be subjective given the knowledge about the subject. Industry view, notably logistics providers tend to be more technology vision because of their traditional logistics organization. Their methods of practicing logistics follow the conventional paradigm of logistics. Thus, any initiative from companies will require a strategic approach. A bottom up approach is proposed by Alice to facilitate adoption in a flawless way. This could be done via performing workshop among stakeholders in order to build a consensus (Alice, 2016).

A blueprint view (2) tend to belong to stakeholder who believe in π to some extent. It is also still essential for them to participate in building of a consensus between key stakeholders. This view actually trends to belong most to people with the highest interest, notably Alice and its key industry members. Researchers in the field of π also have the same view, but their work is more directed toward advocating the perceived benefits such as π business models. In order to reach a consensus with industry key player, this approach is unlikely to make an impact on stakeholders with technology vision. Sternberg and Norrman (2017) called for an investigation on the positive effects before a blueprint work is carried out. It is important for the stakeholders with blueprint view to have an outsider view on the subject that provide insight on where the focus of the work should be. For example, research on the work done about positive benefits, notably business models should focus on more practical analysis to industry stakeholders. To elaborate, studies should not include lots of assumptions for the sake of the simplicity. This could be done by undertaking action research which take into consideration real cases studies.

An engineered system view (3) focus more on the technical and operational part of the system. Given their direct insight with the subject, certain researchers mainly the ones that contributed to the invention of this concept (e.g., Montreuil et al., 2012a; Montreuil et al., 2012c)

6 Conclusion

In this study, a breakdown of π stakeholders has been provided in order to demonstrate the available views on π . Each stakeholder, regardless of its category, looks at π differently from the other, so a consensus is unlikely to achieve without a strategic plan. Thus, a categorisation of these stakeholders has first been provided, followed by an analysis off their importance and contributions. As seen from Figure 2 and 3, this article is not trying to label each view to a specific stakeholder or a category as views differ across all stakeholders. However, a consensus is required to move forward into the implementation of the system.

Future work is suggested within the categorisation and the breakdown of π stakeholders. For example, synergies between logistics government and governance of innovative technology such IoT and Digital Internet will support the development of π governance Sternberg and Norrman (2017) called for further research in this matter to identify legislators and public authorities in domain of the Physical Internet. As enablers are nor gaining enough attention, research need to conducted within their importance in the implementation of π . Examples of π enablers in this context include mainly smart technology providers.

Soft systems methodology has been adopted in order to conceptually analyse the views about the Physical Internet in order to reach an agreement. For this consensus to be reached, this study suggest collaboration in terms of knowledge sharing. A circular information flow (Figure 9) is essential to have a consensus. This methodology can be adopted in different areas of research about the Physical Internet. Further work can be done within the area of conceptualising Physical Internet.

Adopting systems thinking approach to map π stakeholders is beneficial and contributes to the gap. However, the conceptual nature of this paper limits the results to some extent. Future research would provide more insightful results when supported by data from interviews with key stakeholders.

7 References

- Abdoulkadre, A., Intissar, B. O., Marian, M., & Montreuil, B. (2014). *Towards Physical Internet Enabled Interconnected Humanitarian Logistics*. Paper presented at the First International Physical Internet Conference. Québec City, Canada, May.
- Abodohoui, A., Aihounhin, S. P., Mayuto, R., Marif, A., & Montreuil, B. (2014, May 28-30). *Assessing the Readiness of Africa for the Physical Internet*. Paper presented at the First International Physical Internet Conference, Québec City, Canada.
- Alice. (2014). ALICE Recommendations to H2020 Work Programs 2016-2017, December 2014. Retrieved from Alliance for Logistics Innovation through Collaboration in Europe website:
- Alice. (2015). WP4: Global Supply Network Coordination and Collaboration: Research & Innovation Roadmap. Retrieved from Alliance for Logistics Innovation through Collaboration in Europe website: <http://www.etp-logistics.eu/alice/en/publications/>
- Alice. (2016). ALICE Recommendations to H2020 Work Programs 2018-2020. Retrieved from Alliance for Logistics Innovation through Collaboration in Europe website: http://www.etp-logistics.eu/wp-content/uploads/2015/08/ALICE-Recomendations-WPs-2018-2020-v161216.01_rev170117.pdf
- Alice. (2017a). Alliance for Logistics Innovation through Collaboration in Europe. Retrieved from <http://www.etp-logistics.eu/>
- Alice. (2017b). A vision for a transport system supporting sustainable and efficient logistics towards the Physical Internet. Retrieved from Alliance for Logistics Innovation through Collaboration in Europe website: <http://www.etp-logistics.eu/?p=1298>
- Ambra, T., Meers, D., Caris, A., & Macharis, C. (2017). Inducing a new paradigm shift: A different take on synchromodal transport modelling.
- Arnold, R. D., & Wade, J. P. (2015). A Definition of Systems Thinking: A Systems Approach. *Procedia Computer Science*, 44(Supplement C), 669-678. doi:<https://doi.org/10.1016/j.procs.2015.03.050>
- Ballot, E. (2015). The Physical Internet. *workshop on e-Freight "Secure information based collaboration"*, 1-19. Retrieved from bestfact website:
- Ballot, E., Meller, R. D., & Montreuil, B. (2014). *The Physical Internet: The Network of Logistics Networks*: La Documentation Française.
- Ballot, E., Montreuil, B., & Thivierge, C. (2013). Functional design of physical internet facilities: a road-rail hub *Progress in Material Handling Research 2012*: Faculté des sciences de l'administration, Université Laval.
- Ballou, R. H. (2007). The evolution and future of logistics and supply chain management. *European Business Review*, 19(4), 332-348. doi:doi:10.1108/09555340710760152
- Checkland, P. (1999). *Soft systems methodology: a 30-year retrospective* ([New]. ed.). Chichester: John Wiley.
- Cimon, Y. (2014). *Implementing the Physical Internet Real-world Interface: Beyond Business Models*. Paper presented at the First International Physical Internet Conference. Québec City, Canada, May.
- Crainic, T. G., & Montreuil, B. (2016). Physical Internet Enabled Hyperconnected City Logistics. *Transportation Research Procedia*, 12, 383-398. doi:<http://dx.doi.org/10.1016/j.trpro.2016.02.074>
- Engi, D., & Glicken, J. (1995). *The vital issues process: Strategic planning for a changing world*. Retrieved from
- European Commission. (2013). *Report on the public consultation on IoT Governance*. Retrieved from <https://ec.europa.eu/digital-single-market/news/conclusions-internet-things-public-consultation>

- Hakimi, D., Montreuil, B., Sarraj, R., Ballot, E., & Pan, S. (2012, 2012-06-06). *Simulating a physical internet enabled mobility web: the case of mass distribution in France*. Paper presented at the 9th International Conference on Modeling, Optimization & SIMulation - MOSIM'12, Bordeaux, France.
- Houghton, L. (2013). Why Can't We All Just Accommodate: A Soft Systems Methodology Application on Disagreeing Stakeholders. *Systems Research and Behavioral Science*, 30(4), 430-443. doi:doi:10.1002/sres.2136
- Iacovou, C. L., Benbasat, I., & Dexter, A. S. (1995). Electronic Data Interchange and Small Organizations: Adoption and Impact of Technology. *MIS quarterly*, 19(4), 465-485. doi:10.2307/249629
- McFarlane, D., Giannikas, V., & Lu, W. (2016). Intelligent logistics: Involving the customer. *Computers in Industry*, 81, 105-115. doi:10.1016/j.compind.2015.10.002
- Meller, R. D., Ellis, K. P., & Loftis, B. (2012). From horizontal collaboration to the Physical Internet: Quantifying the effects on sustainability and profits when shifting to interconnected logistics systems. *Center for Excellence in Logistics and Distribution, University of Arkansas*.
- Meller, R. D., Montreuil, B., Thivierge, C., & Montreuil, Z. (2012). Functional design of physical internet facilities: a road-based transit center. *Progress in Material Handling Research, MHIA, Charlotte, NC*.
- Mendelow, A. L. (1981). *Environmental Scanning-The Impact of the Stakeholder Concept*. Paper presented at the ICIS.
- Modulushca. (2015). Modular Logisitcs Units in Shared Co-modal Networks. Retrieved from <http://www.modulushca.eu/>
- Montreuil, B. (2009). Physical Internet Manifesto: globally transforming the way physical objects are handled, moved, stored, realized, supplied and used. *Technical Report*.
- Montreuil, B. (2011). Toward a Physical Internet: meeting the global logistics sustainability grand challenge. *Logistics Research*, 3(2-3), 71-87. doi:10.1007/s12159-011-0045-x
- Montreuil, B., Ballot, E., & Fontane, F. (2012a). An Open Logistics Interconnection model for the Physical Internet. *IFAC Proceedings Volumes*, 45(6), 327-332. doi:<http://dx.doi.org/10.3182/20120523-3-RO-2023.00385>
- Montreuil, B., Meller, R. D., & Ballot, E. (2012b). Physical Internet Foundations. *IFAC Proceedings Volumes*, 45(6), 26-30. doi:<http://dx.doi.org/10.3182/20120523-3-RO-2023.00444>
- Montreuil, B., Meller, R. D., Thivierge, C., & Montreuil, Z. (2012c). Functional design of physical internet facilities: a unimodal road-based crossdocking hub. *Progress in Material Handling Research*.
- Montreuil, B., Rougès, J. F., Cimon, Y., & Poulin, D. (2012d). The physical internet and business model innovation. *Technology Innovation Management Review*, 2(6).
- Oktaei, P., Lehoux, N., & Montreuil, B. (2014). *Designing Business Models for Physical Internet Transit Centers*. Paper presented at the First International Physical Internet Conference. Québec City, Canada, May.
- Pan, S., Ballot, E., Huang, G. Q., & Montreuil, B. (2017). Physical Internet and interconnected logistics services: research and applications. *International Journal of Production Research*, 55(9), 2603-2609. doi:10.1080/00207543.2017.1302620
- Patching, D. (1990). *Practical soft systems analysis*. London: Pitman.
- Platt, A., & Warwick, S. (1995). Review of soft systems methodology. *Industrial Management & Data Systems*, 95(4), 19-21.
- Qiao, B., Pan, S., & Ballot, E. (2016). Dynamic pricing model for less-than-truckload carriers in the Physical Internet. *Journal of Intelligent Manufacturing*, 1-13. doi:10.1007/s10845-016-1289-8

- Reed, M. S., Graves, A., Dandy, N., Posthumus, H., Hubacek, K., Morris, J., . . . Stringer, L. C. (2009). Who's in and why? A typology of stakeholder analysis methods for natural resource management. *Journal of Environmental Management*, 90(5), 1933-1949. doi:<https://doi.org/10.1016/j.jenvman.2009.01.001>
- Sallez, Y., Berger, T., Bonte, T., & Trentesaux, D. (2015). Proposition of a hybrid control architecture for the routing in a Physical Internet cross-docking hub. *IFAC-PapersOnLine*, 48(3), 1978-1983. doi:<http://dx.doi.org/10.1016/j.ifacol.2015.06.378>
- Sallez, Y., Pan, S., Montreuil, B., Berger, T., & Ballot, E. (2016). On the activeness of intelligent Physical Internet containers. *Computers in Industry*, 81, 96-104. doi:<http://dx.doi.org/10.1016/j.compind.2015.12.006>
- Sanchez-Rodrigues, V., Potter, A., & Naim, M. (2010). Evaluating the causes of uncertainty in logistics operations. *The International Journal of Logistics Management*, 21(1), 45-64. doi:10.1108/095740910111042179
- Sarraj, R., Ballot, E., Pan, S., & Montreuil, B. (2014). Analogies between Internet network and logistics service networks: challenges involved in the interconnection. *Journal of Intelligent Manufacturing*, 25(6), 1207-1219. doi:10.1007/s10845-012-0697-7
- Shaposhnikova, A. (2017). Physical Internet: Shaping the Future of Global Logistics. *Transmetrics Blog*. Retrieved from <http://transmetrics.eu/blog/interview-with-prof-rod-franklin-physical-internet-shaping-the-future-of-global-logistics/>
- Sternberg, H., & Norrman, A. (2017). The physical internet—review, analysis and future research agenda. *International journal of physical distribution & logistics management*(just-accepted), 00-00.
- Treiblmaier, H., Mirkovski, K., & Lowry, P. B. (2016). Conceptualizing the Physical Internet: Literature Review, Implications and Directions for Future Research.
- Weber, R. H. (2013). Internet of things – Governance quo vadis? *Computer Law & Security Review*, 29(4), 341-347. doi:<http://dx.doi.org/10.1016/j.clsr.2013.05.010>
- Wilson, B. (2001). *Soft systems methodology: conceptual model building and its contribution* (1 ed.). Chichester: Wiley.
- Xu, X. (2013). *Collaboration mechanism in the horizontal logistics collaboration*. Ecole Nationale Supérieure des Mines de Paris.



Do you see what I see? A simulation analysis of order bundling within a transparent user network in geographic space

Tomas Ambra^{1,2,3}, An Caris², Cathy Macharis¹

1. Vrije Universiteit Brussel, MOBI research Centre, Brussels, Belgium

2. Hasselt University, Diepenbeek, Belgium

3. Research Foundation Flanders (FWO), Brussels, Belgium

Corresponding author: tomas.ambra@vub.be

Abstract: *Assuming the universal network openness, the users can tap into the PI network and place orders which will be assigned to the nearest available transport service and consequently delivered to the order sender. The objective of our paper is to investigate the impact of stochastic insertion of service points into existing dedicated freight flows of a service driven company. We simulate different transparency levels, routings and pick-up locations, and evaluate the impact in terms of altered lead-times, covered distances and fill rates. The novel aspects presented herein are 1) deliveries based on decentralized location detection of the nearest order sender, 2) dynamically changing speed parameters within specific geographic clusters based on geo-locations of agents to account for congestion levels, 3) more realistic routing strategies that consider the urban layout and 4) transparent querying of nearest agents in space and time that meet specific conditions such as current ongoing processes, available capacity and position. Finally, we identify impact from a holistic/system perspective based on emergence of individual asset performances.*

Keywords: *Agent-based modelling (ABM), Geographic Information Systems (GIS), Computational modelling, Simulation, SYMBIT.*

1 Introduction

The Physical Internet (PI) concept is to identify dedicated freight flows and transform them into transparent open logistics networks which can be accessed by other users, such as shippers and carriers. In this regard, the longer dedicated freight movements should be decentralized and bundled locally based on available local assets and their parameters. Assuming the universal network openness, the users can tap into the PI network and place orders which will be assigned to the nearest available transport service and consequently delivered to the order sender. The objective of our paper is to investigate the impact of stochastic insertion of service points into existing dedicated freight flows of a service driven company. The impact is measured in terms of lead-times, covered distances and fill rates. The assets of the service driven company seek delivery solutions locally and deliver newly inserted orders en route. To achieve such a spatial and temporal awareness of the assets' and orders' surroundings, we combine agent-based modelling (ABM) and Geographic Information Systems (GIS) to account for decentralized parallel processes of agents in geographic space. The bundling of stochastically generated orders is assessed from a carrier perspective in the Brussels Central Region, from the distribution center to the final end consumer(s). We consider spatial characteristics of the build

environment that govern van (agent) movements, altered distances caused by extra service points, a temporal dimension such as time of the day which changes agent speed parameters in a dynamic manner, distances to existing service points but also distances to newly inserted service points. The status quo that considers no bundling, is compared to 1) order assignment to dedicated vans while considering priority and enroute deliveries, 2) a new central location that serves as a PI hub. This is to evaluate potential decrease in lead-times, higher service levels and lower environmental impact. The last factor is 3) flexible order assignment to the nearest vans that are within a certain radius and have spare capacity. The motivation behind the setting is to simulate the network transparency by assuming that vans carry sensors and share information within their environment. The variations caused by the three factors are statistically analyzed by factorial ANOVA.

2 Related work and positioning

The first formal definition of the PI (sometimes referred to as π) was introduced by Montreuil et al. (2013) who describe it as an open global logistics system founded on the physical, digital and operational interconnectivity through encapsulation, interfaces and protocols. Following this notion, several authors have published work within the PI context. Lin et al. (2014) devise a model for selecting standard modular containers (boxes) for a set of products. Sarraj et al. (2014) numerically demonstrate the potential of merging container flows by interconnecting logistics networks and protocols. An explicit research on π -containers has been carried out by Landschützer et al. (2015) who describe a first engineering process for developing modular and multifunctional load units within the fast-moving consumer goods industry. Pan and Ballot (2015) demonstrate the benefits of knowing asset positions via a framework to optimize the repositioning open container tracing based on radio frequency identifiers (RFID). Pan et al. (2015) provide an exploratory simulation study of inventory control models in PI. Qiu et al. (2015) propose a new business model based on an IoT-enabled infrastructure. Darvish et al. (2016) link the vehicle routing problem with lot-sizing problem in order to address a more holistic production-routing problem. One of the first pricing models in the PI context is investigated by Qiao et al. (2016) to facilitate carriers' decision making with regard to price propositions in a dynamic bidding environment for less-than-truckloads. As far as the inner π -hub operations are concerned, Kong et al. (2016) transform the auction business into a new paradigm in combination with the PI. Walha et al. (2016) study the rail-road π -hub allocation problem where the π -hub is distinguished from a classical road-rail terminal by having modular and standard π -containers. Yao (2016) applies the shared and open PI logistics network in the context of optimizing one-stop delivery scheduling in online shopping. Venkatadri et al. (2016) assess the PI from a shipment consolidation perspective by analyzing traditional distribution and consolidated distribution within a European city network. Zhang et al. (2016) create a new product service system based on a smart box and propose a real-time optimization via a cloud computing platform. Zhong et al. (2016) introduce a manufacturing executive system that makes use of RFID for real-time data collection. Fazili et al. (2017) quantify the benefits and performance of PI compared to a conventional logistics system. Tran-Dang et al. (2017) propose a solution that has the ability to facilitate container encapsulation by detecting errors and providing updates. Salles et al. (2016) focus on the (pro)activeness and information exchange among containers where different grouping strategies within a rail terminal are tested. Yang et al. (2017a) study the impact of disruptions on hubs and factory plants and assess inventory model resilience within a PI environment of interconnected logistics services. Yang et al. (2017b) introduce a PI-based inventory optimization control model. The authors propose a vendor-managed inventory strategy where facilities and transport means are shared based on user demands.

However, little research has been done in terms of order deliveries in cities as most of the literature covers within-hub operations and large national road networks. The first PI city application is addressed by Cranic & Montreuil (2016) who introduce a Hyperconnected City Logistics idea with its fundamental concepts. More recently, Mohamed et al. (2017) study the urban transportation problem in a PI-enabled setting by using different types of vehicles. Chen et al. (2017) make use of the extra loading capacity of taxis to collect returned goods in a city. These existing city applications make use of directed graphs and analytical approaches. Our paper contributes to the existing body of literature by applying simulation modelling which depicts a more detailed time-based component (continuous flow of time). The novel aspects presented herein are 1) en route deliveries based on decentralized location detection of the nearest order sender, 2) dynamically changing speed parameters within specific geographic clusters based on geo-locations of agents and the time of the day which determines congestion levels, 3) more realistic routing strategies that consider the urban layout, 4) transparent querying of nearest agents in space and time that meet specific conditions such as current ongoing process, available capacity and position and 5) identifying impact on lead-times and fill rates. We simulate an integrated logistics system where orders of 2 different shippers/retailers are delivered by the same vehicles owned by a service driven company. The focus is not on the end-to-end supply chain, multi-tier inventory sourcing etc., but rather on the carrier transportation performance within the last-mile delivery in order to assess how such a PI business application could influence established and dedicated processes. Such an applications also addresses the concerns of Sternberg and Normman (2017) who point out that all the PI-related studies do not cover return trips, and this paper is to address such a deficiency. We break the black box paradigm - where routes are predefined in advance and individual decentralized logic of entities cannot be probed during run-time - by creating an open and transparent assignment of orders. This assignment is done based on geolocations of moving assets, their ongoing processes as well as spatial and temporal attributes.

3 Methodology

Our SYnchronization Model for Belgian Inland Transport (SYMBIT) is a computational model, which computes freight movements based on scheduling, decentralized behavior rules and information flows of entities/agents. The goal of the computational approach is to facilitate shippers' decision making by computing and estimating what-if scenarios in a risk free environment while considering their own lead-time and cost constraints.

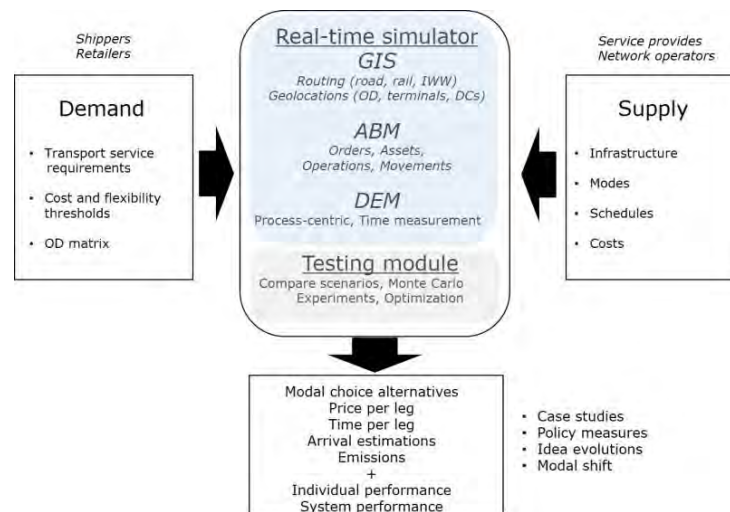

Figure 3-1: General overview of SYMBIT's composition together with its inputs and outputs

The main modelling canvas is a digital map that comprises of road, rail and iww shapefiles. The GIS environment presented herein provides our agents with real-world locations based on the WGS84 geographic coordinate system, having Greenwich (0, 0) as its prime meridian. The reason behind choosing the WGS84 coordinate system is its broad application; used as a reference system by GPS, Google Maps as well as by Microsoft in its Bing Maps. This digital infrastructure is part of the transport “Supply” (Figure 3-1, right) that also includes existing services and schedules that induce agent movements. We have chosen Anylogic software as it offers ready-to-use agent and GIS components. SYMBIT uses agents as its core elements which flow through its sub-parts. The parts consist of moving and stationary agents. The former are objects that flow between stationary agents such as distribution centers (DCs) and retailers/end-consumers. Compared to abstract mathematical modeling environments, agents have the ability to roam geographical space and record data. The advantages of using GIS for these processes lay in more accurate and realistic routing strategies, detection of events in space and time during execution, and efficient response actions that are facilitated by location intelligence. In other words, the moving agents collect distance data that they have covered or are about to cover. The data collection may be done dynamically without switching manually to google maps or other providers to acquire distances. Each agent also possesses a speed parameter that governs the agents speed throughout its movement. A type of setting like this also facilitates calculation of Estimated Times of Arrival (ETAs).

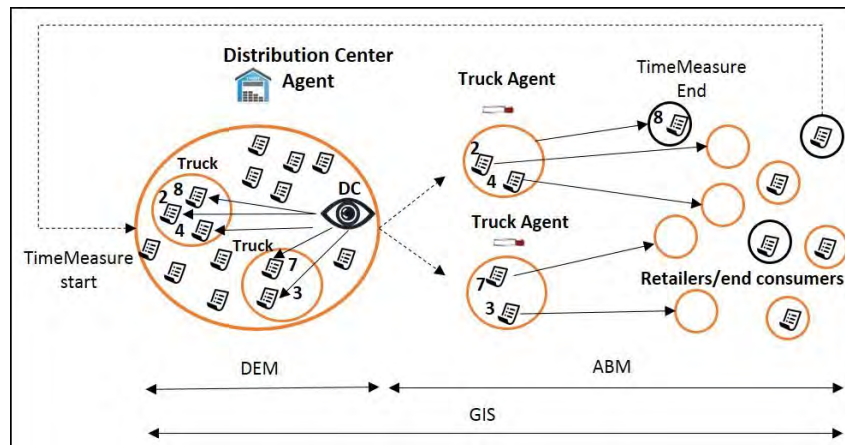

Figure 3-2: Conceptual illustration of SYMBIT's components where in-house DC processes (stationary agents) comprise of discrete-event modelling, movement between stationary agents is carried out by moving agents (vans, cars...) and GIS that provides location and routing attributes to moving and stationary agents.

Figure 3-2 represents a conceptual overview of an order flow starting at a distribution center agent and ending at a destination node which can be a retailer or an end consumer. SYMBIT continuously monitors the state of agents from the point when the order agent is sent to the DC (Figure 3-2, left). It then logs the type of transport means the order is carried by, covered individual distances, elapsed time, dwelling time, and last-mile delivery which stops the monitoring process of a specific order at TimeMeasureEnd.

Having SYMBIT as an agent-based model, we exploit the ability to simulate and assess communication structures based on a certain level of transparency determined by the modeler. This is possible due to the ability of agents to send messages that are assumed to be transmitted via sensors; various examples of sensors and preceptors can be found in Ambra et al. (2017). The stationary agents (shipper or its DC) intercept orders via agent communication links which allow information exchange on a unidirectional or bidirectional basis. The order then flows through discrete event blocks and are assigned to moving agents of the service provider's resource pool. Agents are spatially explicit and have a location in geographical space. Decisions

of agents are influenced by the available information and data in their network which means some decision outcomes may vary due to the existence or absence of information, for instance, resource availability/capacity and congestion links. The studied logistics metrics, such as fill rate, inventory costs, time, accepted orders, distance, detected incidents, current position and route, can be recorded in log files keeping track of agents' movements and events. In this paper we focus mainly on fill rates, lead-times and distances.

4 Experimental design

The initialization consists of populating the model by locations of stationary agents and initial (home) locations of moving agents. Blue locations of customer2 (Figure 4-1) are taken from Atrium database – the Chamber of Commerce of the Brussels-Capital Region. A 'Google Maps Geocode API' is then used to acquire latitude and longitude for each location. The initial location of 'Customer2 car' is evenly distributed among Customer2 locations, assuming that each storeowner has one vehicle at his/her disposal. The green locations are queried via Google and based on their coordinates, these are converted into GIS space markup.

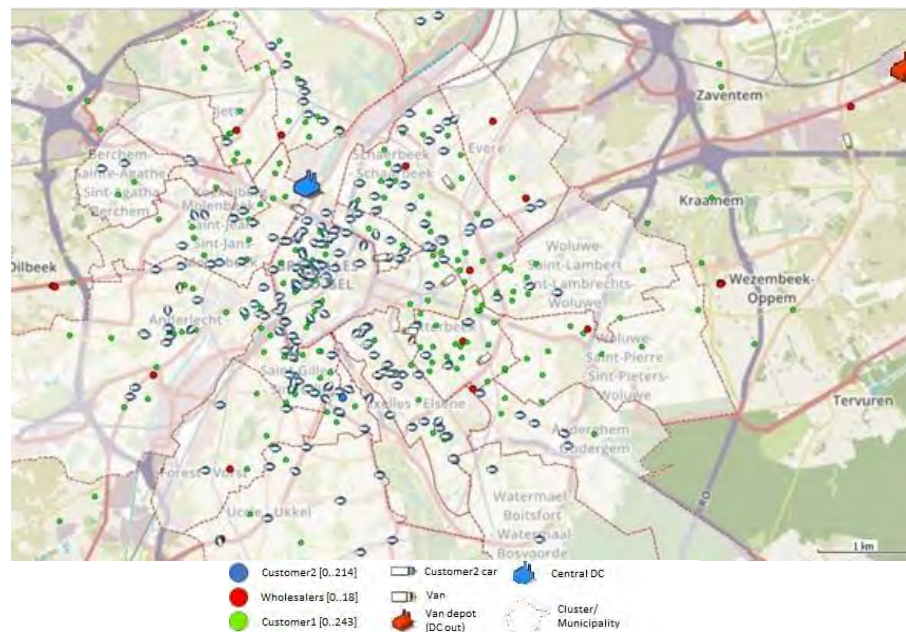

Figure 4-1: Study area depicting the geographical region of Brussels and its municipalities.

These green locations represent core customers (Customer1) of the LSP. The last step is to geocode a central DC agent which corresponds to a PI-hub and a van depot of a service-driven company (LSP) which governs a fleet of 20 vans. The remaining 19 red dot locations are selected wholesalers where customers from the customer2 group go to replenish by using their own fleet. This process is decentralized; each customer2 agent will take its corresponding customer2 car and depart to the nearest wholesaler to him. Afterwards, SYMBIT also monitors return trips from the wholesaler's location back to the Customer2 initial location. All these parallel movements are recorded in a log file.

4.1 Case description and procedural logic of van agents

The study considers existing vans with spare capacity that are physically present in the city. They transport "air" most of the time which is why customer2 orders are being considered to use this capacity and prevent customer2 group from going to the nearest wholesaler to replenish. Van agents are the core elements governed by the experimental design depicted in Figure 4-2.

Based on Kin et al. (2018), one single customer out of the customer1 group generates demand up to 3 times per day, whereas stores replenish their stores 3 to 6 times per week by going to the nearest wholesaler. For clarity purposes, we will refer to stores as customer2. The business as usual case (status quo) consists of van agents delivering to customer1 locations who generate orders with geo-coordinates of their origin. This demand is defined by a uniform distribution function with bounds between 0 and 3. The van agents are initiated by a service schedule that starts at 9am, and they consequently follow processes displayed under status quo (Case 0). Once a matching algorithm assigns orders to a corresponding van via postal codes, the van agent calculates all distances to the order destinations and departs to the nearest one by route. After unloading, it recalculates all order distances from its new position and moves to the next nearest order location. If the individual order list queue is empty, the agent returns back to the DC. In terms of randomness in the demand generator, we use a fixed seed value to ensure reproducible simulation runs. The model run time is confined to 1 day given the computational power required for agent speed control and geo-fencing which will be described in the following section. Having established these dedicated flows, we introduce 3 factors in order to assess how the current structure would be impacted and whether the impact is of significance. The impact is measured by distance, lead-times and fill rates.

The factors we evaluate are: Location (outside, central), external website orders (10%, 25%, 50%, 75%, 100%) and delivery logic (priority, enroute, dedicated, transparent). Priority means customer1 orders (o1) are delivered first and customer2 orders (o2) as last. Enroute queries all the order locations (o1 and o2) in geographic space, and the van agent re-calculates and compares distances to each one of them from its individual location which changes after every order delivery. Both, priority and enroute, have o2 onboard from the DC outside (Case 1). We then measure the performance of the van fleet if the extra o2s need to be collected from a central DC (Case 2). The central DC can be perceived as a new PI hub which is located in the port of Brussels. The last setting (Case 3) considers only the central DC and simulates 2 different order allocation and notification schemes; Firstly, the central DC (PI hub) notifies dedicated vans that serve the specific clusters/municipalities from where the o2 come from. Secondly, the o2 allocation is carried out in a transparent manner when the central DC has the ability to spatially detect the nearest moving agent, but also the number of orders/objects the van has onboard. It then requests the nearest van agent with the lowest number of orders onboard. This case works with an assumption that vans carry sensors and share information within their environment. In this regard, "Do you see what I see?" refers to the level of transparency the 2 allocation schemes in case 3 have; in which the first allocation logic is not aware of nearest vans and their parameters and the second allocation logic is.

We pose and test the following hypotheses:

Hypothesis 1 (case 1): Insertion of Customer2 website orders into existing van deliveries has a significant effect on Customer1 orders in terms of 1a) lead-times, and vans' b) load factors and 1c) distances.

Hypothesis 2 (case1): Delivery logic has a significant effect on Customer1 orders in terms of 2a) lead-times, and vans' 2b) load factors and 2c) distances.

Hypothesis 3 (case 2): Location has a significant effect on Customer1 orders in terms of 3a) lead-times, and vans' 3b) load factors and 3c) distances.

Hypothesis 4 (case 3): Transparent allocation/delivery logic performs better than dedicated allocation/delivery logic in terms of 4a) lead-times, 4b) load factors and 4c) distances.

Hypothesis 5: the joint effect of any of the 3 factors is significant.

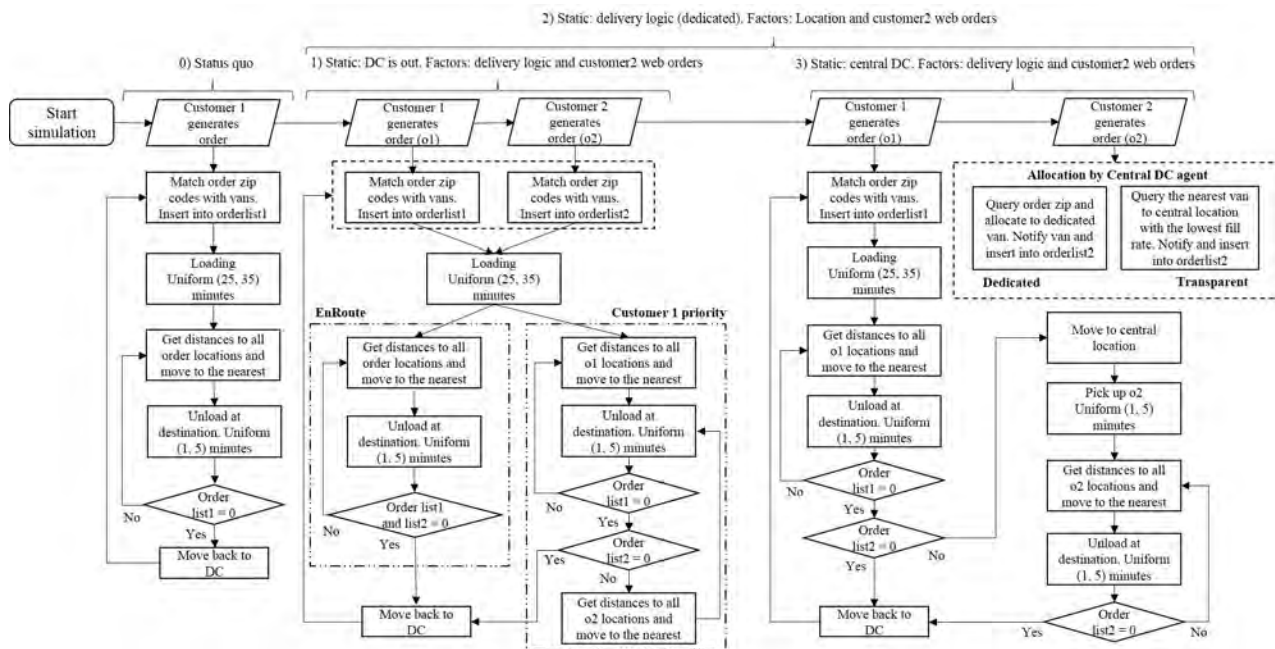

Figure 4-2: Schematic overview of the business-as-usual case (status quo) and 3 experimental simulations and their composition.

4.2 Geo-fencing and speed adjustment

When van agents roam the environment from/to order locations, it is unrealistic to use a constant average speed parameter. Therefore, we deploy geo-fences that probe vans' speed parameters. In order to determine what speed corresponds to a municipality, we sampled historical data from commercial map providers. The speed parameter that governs each agent movement is deduced from distance and elapsed time by applying basic physics $s = (d/t)*3.6$ where s is speed, d is distance in meters and t is elapsed time in second. Factor 3.6 is to acquire km/h. We measured distances within every cluster from 4 edges to the centroid. The commercial map provider then offered elapsed time which is used for speed deduction. Alternatively, speed profiles can be used when agents are govern by the properties of the route polyline. However, these polylines contain max. allowed speeds but no realistic daily speeds.

The proposed geographical clusters are characterized by a list of latitude-longitude pairs. Since agents may roam this geographical space, the speed parameter can be dynamically probed while moving; once an agent enters a certain geo-fence, a matching algorithm is deployed to compare x and y coordinates of the agent's location with the cluster's latitude-longitude pairs to identify which speed each agent has to adapt. Another parallel algorithm monitors the real-time simulator in order to switch speed values according to the time of the day (Table 4-1). This ensures that morning, noon and afternoon deliveries reflect realistic congestion levels. The routing and service points are not predefined in advance since customer2 order generation is stochastic and each time a different agent may deliver the goods based on its current position and ongoing process in space and time. For this reason, cluster speeds may be more advantageous compared to predefined individual speed profiles per entity. The van agent's speed logic could be also linked to an API that fetches real-time data, however this approach goes beyond the scope of our paper.

Table 4-1: Speed parameters (km/h) per each geographical cluster during a given time of the day.

Cluster	8 - 10 h	10-12 h	12-14 h	14-16h	16-18 h	18 - 20 h
Brussels	10,4	11,4	12,9	12	14	12,8
Schaerbeek	16,5	16,5	16,5	18,5	14,6	16,5
Etterbeek	12,6	15,7	15,7	15,7	12,6	12,6
Ixelles	13,3	18,4	18,4	18,4	16	17,1
Saint Gilles	13	13	13	13	12	13
Anderlecht	16,8	13,5	13,5	12,4	12,4	16,2
Molenbeek-St-Jean	15,7	18,7	18,7	16,6	13	17,6
Koekelberg	14,4	13,1	13,1	14,6	12	13,1
Berchem-St-Agathe	18	18	16,6	15,4	14,4	18
Ganshoren	13,2	16,5	16,5	14,6	13,2	16,5
Jette	20	17,1	18,4	17,1	16	17,1
Evere	18,4	18,4	17,3	19,7	16,2	18,4
Woluwe-St-Pierre	27,6	30,6	30,6	30,6	30,6	25,1
Auderghem	14,5	17	20,4	18,5	12,6	20,4
Watermael-Boitsfort	22,3	24	24	24	18,4	24
Uccle	16,2	40,5	40,5	21,6	19,1	27
Forest	18,9	22	22	18,5	13,2	20,3
Woluwe-St-Lambert	18,5	22	26,4	22	26,4	22

St Josse-ten-Noode	10	12	13	11,1	7,8	13
Ring road	31,4	61	61	54,9	36,6	54,9

4.3 Object detection and load factor calculation

Given the decentralized nature of agents, load factor calculations may be carried bottom-up without averaging, hence losing, individual specificities that are generated at the local level. In other words, equation-based or analytical models do not generate movements themselves, but use observables that “are moved” by the high-level system. Van agents store their distances they covered but also the objects they carried and unloaded. Given such an object oriented approach, the vehicle load factor VLf is calculated as follows:

$$VLf = \sum_{i=0}^n \left(\frac{D_{Lf,i}}{T_d} \times L_{f,i} \right) + \dots + \left(\frac{D_{Lf,n}}{T_d} \times L_{f,n} \right) \quad (1)$$

Where $L_{f,i}$ is load factor of the first delivery, $D_{Lf,i}$ is distance travelled with $L_{f,i}$, and T_d is the total distance. Example A (Figure 4-3) depicts the vehicle load factor as $VLf = (0.5 \times 80\%) + (0.5 \times 0\%) = 40\%$. However, the number of stops may vary as individual vans receive a different amount of stochastically generated orders. In this regard, example B provides a more accurate representation that is relevant to our case study.

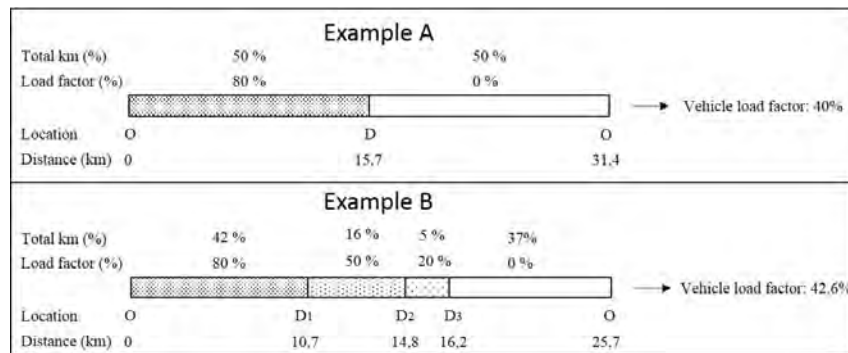

Figure 4-3: Conceptual overview of load factor calculations for a vehicle round trip. O and D depict origins and destination.

An important element to point out is the load factor does not always have a decreasing trend in function of distance and unloading, but can be increased in case the van departs to the centrally located DC to collect o2; after the last destination (D_3), the load factor will increase once the van collects an order from the central DC until the extra customer destination (not shown). The overall VLf per trip is calculated upon return to the DC once we know the total distance.

5 Results and discussion

This section provides a statistical analysis of the simulation output produced by our computational model. It is carried out by a means of ANOVA as running multiple t-tests would increase the type 1 error rate (alfa error) – higher probability that we will reject the null hypothesis when it is in fact true. We thus used a factor significance test ANOVA to assess the interaction effect of the factors on the dependent variables. The following sub-sections describe these effects per depended variable. Firstly, case 1 and 2 are analyzed in order to see how the location factor, delivery logic and amount of web orders affect the service-driven company’s performance (section 5.1). Secondly case 3 is described where the focus is on transparent

allocation and its impact (section 5.2). Significance level of 0.05 is used which relates to confidence intervals of 95%. Furthermore, Bonferroni confidence interval adjustment is deployed to compare main effects of the mean values.

5.1 Impact of extra service point insertion into existing flows

Simulation results for lead-time (Figure 5-1) show a significant increase in customer1 order deliveries when inserting extra service points of customer2 orders with a p-value of 0.000. In order to establish the stage at which the variance becomes significant, pairwise comparison is used that indicates 75% of orders as a threshold (p-value = 0.008) when the extra service points start to have an impact on the customer1 deliveries. This means customer1 orders are not substantially affected if the service driven company receives 50, 25 or 10% of website orders from customer2. In terms of delivery logic Figure 5-1 (left) shows slightly better performance when customer1 orders are delivered as priority and the delay increases with enroute as vans attend to customer2 orders first if they are closer. This increases the delay slightly (blue line) since vans deviate from their original route. However, the variance between enroute and priority is not significant (p-value = 0.177). Website orders and delivery logic interaction have no significant effect (p-value = 0.740). As for the central and outside dc location (Figure 5-1, right), lead-times increase once vans do not load customer2 orders at their depot (outside location) but need to travel to the central location to collect the orders. The deviation leads to a significant increase of customer1 order lead-times (p-value = 0.012) as vans spend more time in the city and return back later to their depot to serve new customer1 orders.

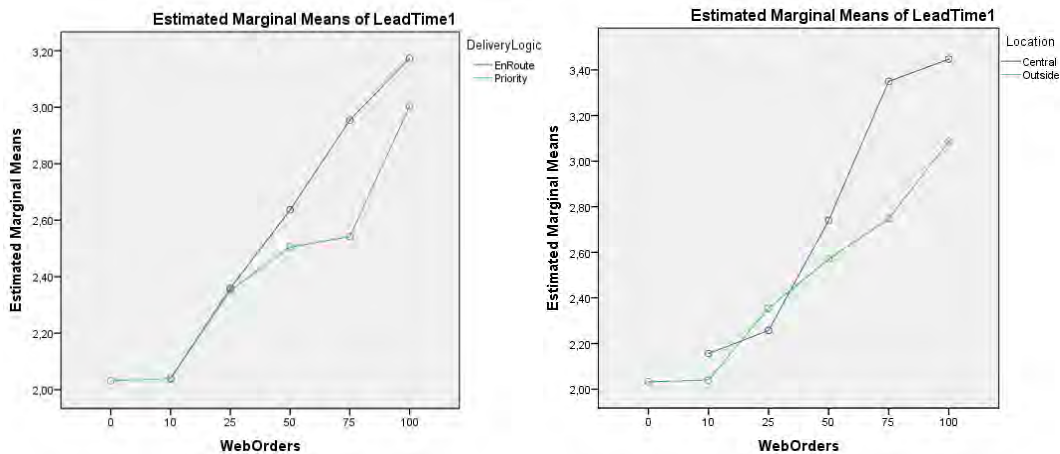

Figure 5-1: Average lead-time of customer1 orders in hours after inserting website orders of customer2 in combination with delivery logic (left) and DC location (right)

Figure 5-2 depicts van load factor variations. Website orders (p-value = 0.216) and delivery logic (p-value = 0.688) have statistically no significant effect on the van load factors when following priority or enroute delivery logic (left). Furthermore, both order groups are delivered from the outside DC location as a result of which vans still cover a lot of empty kilometers on their return trips. However, the load factor increases significantly (p-value = 0.000) when vans substitute these empty kilometers by going to the central DC (right) and consequently deliver customer2 orders once they are done with customer1 orders. This approach appears to outweigh the initial higher load factor when having both orders onboard from the outside dc. In other words, the vans cover less kilometers transporting “air”.

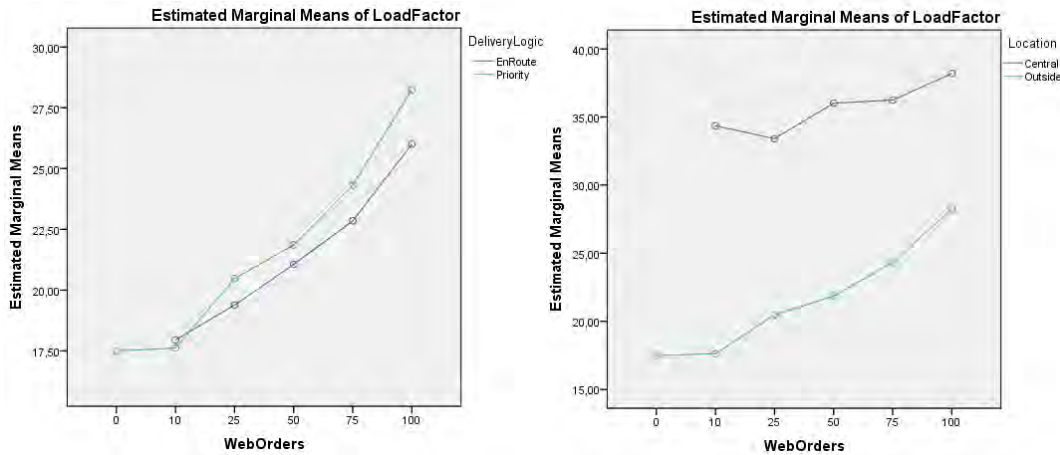

Figure 5-2: Average load factors of vans in % after inserting website orders of customer2 in combination with delivery logic (left) and DC location (right)

Variations in van distances do not follow a clear pattern (Figure 5-3). Enroute deliveries are visually more efficient in terms of kilometers but the statistical analysis yields insignificance (p-value = 0.743). Website orders also do not affect travelled distances (p-value = 0.792). This is a promising results showing that extra orders do not necessarily generate substantially more driven kilometers if vans collect customer2 orders from the central location (PI-hub). The rapid decline in distance from 75% to 100% (left) can be explained by the spatial attributes of the urban layout and the routing algorithm used by our vans. The vans follow the fastest route and a smaller amount of orders located on the western side of Brussels will lead to vans taking the ring road to reach those geo-locations. However, with more orders entering the scene, some vans are dragged closer to the center of Brussels from the clusters' peripheries. This is an interesting emerging phenomena that causes the vans to ignore the ring road and take the inner roads instead when returning back to depot. As far as the location factor is concerned, distance variations are also not significant (p-value = 0.472). Although, there is a visual difference once the vans deviate to the central DC to collect customer2 orders, the variations are negligible.

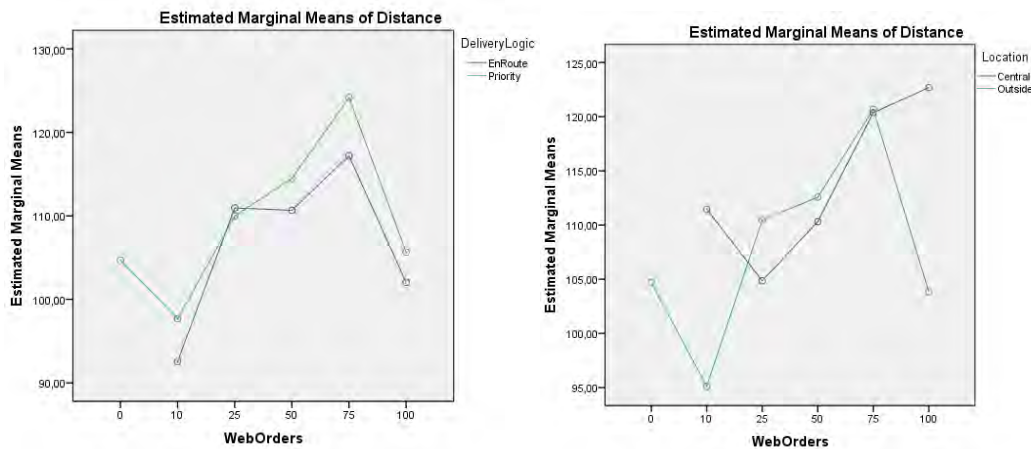

Figure 5-3: Average distances of vans in kilometers after inserting website orders of customer2 in combination with delivery logic (left) and DC location (right)

To summarize and address our posed hypotheses, website orders of customer2 group do have a significant effect on customer1 lead-times starting from 75% (H1a), but no significant effect is observed on load-factors (H1b) and distances (H1c). The delivery logic does not significantly

affect lead-times (H2a), load-factors (H2b) nor covered distances (H2c). The location does have a significant effect on lead-times (H3a) and it substantially increases load-factors of vans (H3b) without significant variations of covered distances (H3c).

5.2 Impact of spatial detection and transparent allocation of orders from a central (PI) location

This section concerns dedicated and transparent order assignments/deliveries from the central location with a goal to evaluate which depended variables benefit from transparency and transparent order allocation to vans with exposed parameters such as fill rates and geo-locations. In the previous section we established that the amount of web orders has a significant effect on customer1 lead-times starting from 75%. Figure 5-4 (left) illustrates that transparent order allocation to the nearest van with the lowest fill rate causes a significant (p-value = 0.020) increase in customer1 order lead-times. On the other hand, transparent order allocation has stronger significance (p-value = 0.000) by decreasing customer2 order lead-times (right). Based on the visual inspection of the figure below, transparent deliveries are less severe for customer1 orders (left) than dedicated deliveries for Customer2 orders (right). In this regard, transparent allocation can benefit mainly the group of customer2 with a slightly lower delivery performance for the customer1 group. This development could attract more users to join the PI open network and additional delays could be offset by additional revenues generated by new customers. Extra fleet or additional service driven companies could also mitigate the burden of extra order influx.

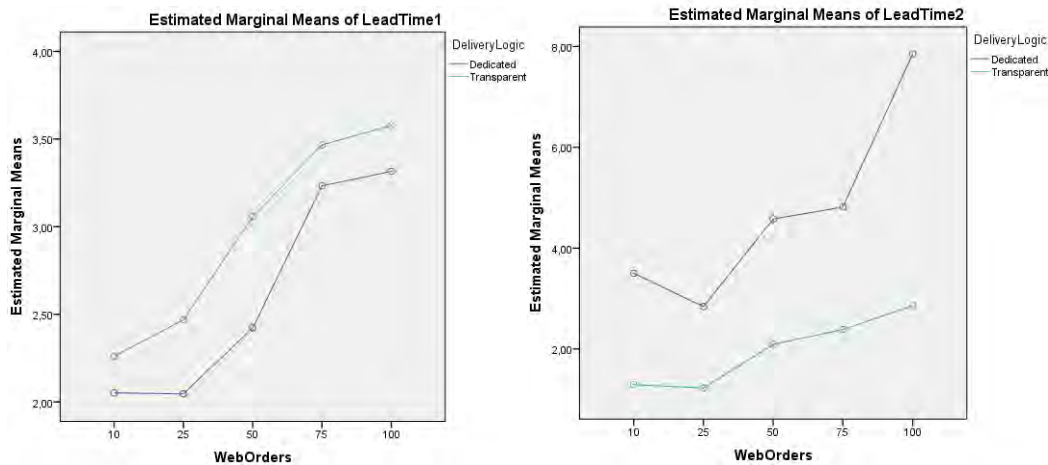

Figure 5-4: Average lead-times of customer1 (left) and customer2 (right) orders in hours after inserting website orders of customer2 in combination with delivery logic.

As for load factors (Figure 5-5, left) the amount of web orders does not cause wide variations (p-value = 0.429) as also described in the previous section. The delivery logic affects the load factor (p-value = 0.000) where transparent allocation, perhaps surprisingly, decreases the load factor compared to dedicated allocation. This can be explained by the already low amount of orders in the vans that were passing by the central DC. In other words, orders that would be normally allocated to dedicated vans, hence increasing overall fill rates of rather full vans of specific clusters, are now allocated to nearly empty vans that serve not so dense clusters. This setting thus contributes to more kilometers travelled with lower fill rates. A testament to this fact is provided by the same figure (right) which indicates that vans start generating more kilometers as the central location agent assigns vans to customer2 orders which may be located in 2 different clusters, subsequently increasing vehicle kilometers. Statistically however, the

distance variations are not significant ($p\text{-value} = 0.305$) when considering the 2 delivery logic levels.

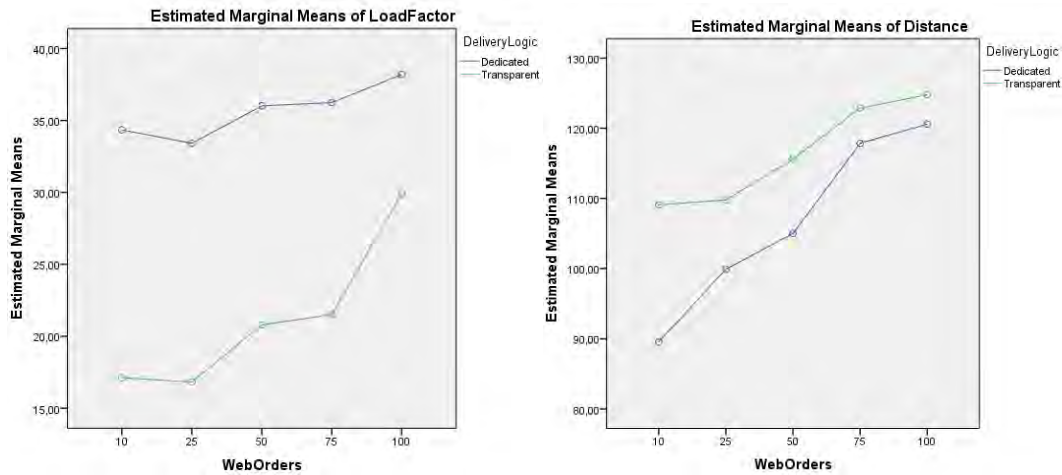

Figure 5-5: Average load factors of vans in % after inserting website orders of customer2 (left) and average distances of vans in kilometers after inserting website orders of customer2.

As far as hypothesis 4 is concerned, transparent allocation has a significant effect on lead-times (H4a) as well as on vans' load-factors (H4b). Distances are not substantially affected by the transparent delivery logic. The transparent allocation does perform better for customer2 group but does not perform better for the core customer1 group and van load-factors.

The transparent allocation can be perceived as a good selling proposition in terms of customer2 lead times at the expense of lower fill rates and slightly more kilometers. The fill rate variations are significant but the extra distances are not. From an environmental point of view, a rather stable amount of kilometers and lower fill rates may emit less pollutants compared to more loaded vans. In fact, the transparent delivery logic is faster for customer2 group, does not yield significantly more kilometers, and could emit less pollutants; from a system perspective, the vans are still present in the city anyway, but they eliminate customer2 car vehicle kilometers (vkm) to the nearest wholesaler (Figure 5-6). It can be observed that despite the vkm increase in vans caused by extra service points, the customer2 vkm overcompensate for this increase which results in a general decrease of total vkm from a system perspective. Hence, such a development may lead to reduction of the amount of vehicles in cities and less external effects such as congestion, noise, emissions etc.

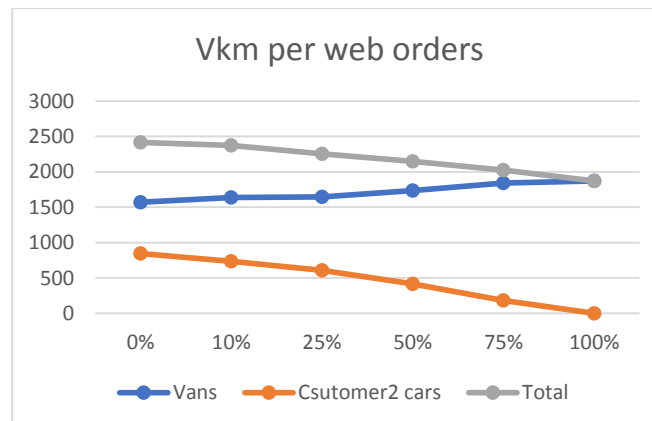

Figure 5-6: A system perspective depicting total vehicle kilometers (vertical axis) of cars and vans within a city as a reaction to increasing percentage of inserted online orders (horizontal axis) of customers from customer2 group.

Having a reliable and fast service offer, will convince new users to place an order within a PI-like network instead of using their own transport means for individual replenishments. An alternative to this approach is to follow the dedicated allocation which generates higher fill rates, but also significantly higher lead-times for customer2 group that could consequently cause a reverse effect and decrease the probability of customers from the customer2 group to place an order online. Customer2 lead-times is also the only dependent variable which is significantly affected by the joint effect of 2 factors, namely website orders and delivery logic (p-value = 0.000). Other factors and their joint effects are not significant (hypothesis 5).

6 Concluding remarks

Research implications

Our work presents decentralized and autonomous allocation in geographic space that allows for testing various delivery algorithms in a more realistic manner within a risk free environment. Compared to mathematical/analytical approaches, an object-oriented agent based model can capture more details and make roaming entities be aware of their surroundings. Such a level of agent decentralization linked to spatial and temporal awareness of surrounding entities as well as information, can offer higher accuracy and more precise forecasts of emerging, and not yet well understood, phenomena. In other words, a simulation study can help identify risk and find more robust solutions before pilot implementations. In terms of geo-fencing and speed adjustment, data fetching tools could be connected to provide constant/continuous speed monitoring when deployed for other days or seasons of the year. Our geo-fences do not necessarily need to have a speed governing purpose only, but may be transformed into a notification source that notifies costumers or DCs about van's location and their estimated times of arrival. Therefore, our study could be linked to the existing body of literature which focuses on inner PI-hub operations by allowing hubs to proactively adjust their local solutions once they become informed about asset arrivals. Given the fact the simulations yielded positive results when introducing the PI-hub closer to the consumers, it may serve as a starting point to link urban flows (perceiving city operations as the local 'intranet') to inter-regional flows (perceiving these longer distance flows as the physical 'internet'). The PI-hub location is centered within the port of Brussels which can serve as a confluence of interregional shipments being carried by inland waterways and urban shipments to account for synchromodal door-to-door solutions. In fact, such a link could reduce road congestion in Flanders (around Brussels) by decreasing truck movements and inducing more barge movements, and also within Brussels as this paper demonstrates.

Managerial implications

From the core customer group (customer1) perspective and its LSP, the service-driven company's fleet is impacted once 75% of new customers (customer2) place an order. It does not matter whether the orders are delivered in a priority-based or enroute fasion. This means the core business of the service driven company does not have to be necessarily affected as the core customers may be delivered as first, provided the extra orders do not exceed 75%. When customer2 orders are collected from the LSP's depot, the load factors do not increase as return trips are still empty. In this regard, the best way to increase load factors is to collect customer2 orders from a central location which is also beneficial for customer2 group in terms of lead-times. From the perspective of custmer2 group, transparent allocation generates faster lead-times. Once extra order insertion exceeds the 75% threshold, additional service driven companies, taxi services or crowdsourcing solutions could ameliorate delivery times and provide more reliable and faster service. The central PI-hub location would be beneficial for these potential new service providers as it is located closer to the customer demand. Our work

illustrates that private car journeys can be eliminated by existing service flows of a service driven company with reasonable delays incurred in their priority flows. From a system perspective/holistic point of view (Figure 5-6), not only could the negative impact of freight logistics and private mobility be reduced to zero, but it could also become negative, when compared to status quo. However, this research avenue still needs more consideration in terms of used vehicles and engine types combined with our load factors and driven kilometers. In reality, service driven companies can use the decentralized local detection via GIS platforms that provided real-time updates of asset locations and their parameters. Such platforms allow to impose geo-fences to receive notifications and messages once moving assets enter a certain catchment of a DC or any other location. Such allocations can be tested with the resource pool of a single service driven company, or with combined assets of more companies with similar flows in the area.

Future research could focus on extending our work by accounting for CO₂ and PM emissions. More complexity could be also included in the current solution where vans do not collect orders from the central location after priority-based orders are delivered, but carry out this collection when the vans pass nearby the hub. This type of enroute collection setting would require the experimental design to shift from “soft” allocation, where the matching algorithm notifies the van with the lowest fill rate to collect a new order and the van departs to the PI-hub after delivering all on board, to “hard” allocation, where the algorithm is less benevolent and takes the first nearest van headed towards the PI-hub regardless of the vans ongoing process or the amount of core customer orders onboard.

References

- Ambra, T., Meers, D., Caris, A., & Macharis, C. (2017). Inducing a new paradigm shift: A different take on synchromodal transport modelling. In C. Landschützer (Ed.), 4th International Physical Internet Conference (pp. 4-18). [1] Graz, Austria: Technischen Universität Graz.
- Chen, C., Pan, S., Wang, Z., & Zhong, R. Y. (2017). Using taxis to collect citywide E-commerce reverse flows: a crowdsourcing solution. *International Journal of Production Research*, 55(7), 1833-1844.
- Crainic, T. G., & Montreuil, B. (2016). Physical Internet Enabled Hyperconnected City Logistics. *Transportation Research Procedia*, 12, 383-398.
- Darvish, M., Larrain, H., & Coelho, L. C. (2016). A dynamic multi-plant lot-sizing and distribution problem. *International Journal of Production Research*, 54(22), 6707-6717.
- Fazili, M., Venkatadri, U., Cyrus, P., & Tajbakhsh, M. (2017). Physical Internet, conventional and hybrid logistic systems: a routing optimisation-based comparison using the Eastern Canada road network case study. *International Journal of Production Research*, 55(9), 2703-2730.
- Kin, B., Ambra, T., Verlinde, S., & Macharis, C. (2018). Tackling Fragmented Last Mile Deliveries to Nanostores by Utilizing Spare Transportation Capacity—A Simulation Study. *Sustainability*, 10(3), 653.
- Kong, X. T., Chen, J., Luo, H., & Huang, G. Q. (2016). Scheduling at an auction logistics centre with physical internet. *International Journal of Production Research*, 1-21.
- Landschützer, C., Ehrentraut, F., & Jodin, D. (2015). Containers for the Physical Internet: requirements and engineering design related to FMCG logistics. *Logistics Research*, 8(1), 1-22.

- Lin, Meller, R. D., Ellis, K. P., Thomas, L. M., & Lombardi, B. J. (2014). A decomposition-based approach for the selection of standardized modular containers. *International Journal of Production Research*, 52(15), 4660-4672.
- Mohamed, B. I., Klibi, W., Labarthe, O., Deschamps, J.-C., & Babai, M. Z. (2017). Modelling and solution approaches for the interconnected city logistics. *International Journal of Production Research*, 55(9), 2664-2684.
- Montreuil, B., Meller, R. D., & Ballot, E. (2013). Physical internet foundations *Service Orientation in Holonic and Multi Agent Manufacturing and Robotics* (pp. 151-166): Springer.
- Pan, S., & Ballot, E. (2015). Open tracing container repositioning simulation optimization: a case study of FMCG supply chain *Service Orientation in Holonic and Multi-agent Manufacturing* (pp. 281-291): Springer.
- Pan, S., Nigrelli, M., Ballot, E., Sarraj, R., & Yang, Y. (2015). Perspectives of inventory control models in the Physical Internet: A simulation study. *Computers & Industrial Engineering*, 84, 122-132.
- Qiao, B., Pan, S., & Ballot, E. (2016). Dynamic pricing model for less-than-truckload carriers in the Physical Internet. *Journal of Intelligent Manufacturing*, 1-13.
- Qiu, X., Luo, H., Xu, G., Zhong, R., & Huang, G. Q. (2015). Physical assets and service sharing for IoT-enabled Supply Hub in Industrial Park (SHIP). *International Journal of Production Economics*, 159, 4-15.
- Sallez, Y., Pan, S., Montreuil, B., Berger, T., & Ballot, E. (2016). On the activeness of intelligent Physical Internet containers. *Computers in industry*, 81, 96-104.
- Sarraj, R., Ballot, E., Pan, S., Hakimi, D., & Montreuil, B. (2014). Interconnected logistic networks and protocols: simulation-based efficiency assessment. *International Journal of Production Research*, 52(11), 3185-3208.
- Sternberg, H., & Norrman, A. (2017). The Physical Internet—review, analysis and future research agenda. *International Journal of Physical Distribution & Logistics Management*, 47(8), 736-762.
- Tran-Dang, H., Krommenacker, N., & Charpentier, P. (2017). Containers monitoring through the Physical Internet: a spatial 3D model based on wireless sensor networks. *International Journal of Production Research*, 55(9), 2650-2663.
- Venkatadri, U., Krishna, K. S., & Ülkü, M. A. (2016). On Physical Internet logistics: modeling the impact of consolidation on transportation and inventory costs. *IEEE Transactions on Automation Science and Engineering*, 13(4), 1517-1527.
- Walha, F., Bekrar, A., Chaabane, S., & Loukil, T. M. (2016). A rail-road PI-hub allocation problem: Active and reactive approaches. *Computers in Industry*, in press.
- Yang, Y., Pan, S., & Ballot, E. (2017a). Mitigating supply chain disruptions through interconnected logistics services in the Physical Internet. *International Journal of Production Research*, 55(14), 3970-3983.
- Yang, Y., Pan, S., & Ballot, E. (2017b). Innovative vendor-managed inventory strategy exploiting interconnected logistics services in the Physical Internet. *International Journal of Production Research*, 55(9), 2685-2702.
- Yao, J. (2016). Optimisation of one-stop delivery scheduling in online shopping based on the physical Internet. *International Journal of Production Research*, 1-19.
- Zhang, Y., Liu, S., Liu, Y., & Li, R. (2016). Smart box-enabled product–service system for cloud logistics. *International Journal of Production Research*, 54(22), 6693-6706.
- Zhong, Gong, H., Xu, C., & Lu, S. (2016). Physical Internet-Enabled Manufacturing Execution System for Intelligent Workshop Production. *International Journal of Signal Processing, Image Processing and Pattern Recognition*, 9(6), 121-132.



Impact of Modular Containerization and Continuous Consolidation on Hyperconnected Parcel Logistics Hub Design and Performance

Shannon Buckley^{1,2} and Benoit Montreuil^{1,2,3,4}

1. H. Milton Stewart School of Industrial & Systems Engineering, Georgia Institute of Technology, Atlanta, United States
 2. Physical Internet Center, Georgia Institute of Technology, Atlanta, United States
 3. Supply Chain & Logistics Institute, Georgia Institute of Technology, Atlanta, United States
 4. Coca-Cola Chair in Material Handling and Distribution, Atlanta, United State
- Corresponding author: Sbuckley8@gatech.edu

Abstract: *The current trend in the parcel logistics industry is towards customers having ever greater power. Thus, to stay competitive, service providers must offer a broader range of more convenient products, which allow customers to receive their goods not only faster, (on the order of a day, or even a few hours), but also at more specific times. This trend presents major challenges for the service providers because supply chains are already suffering from many inefficiencies, including empty travel and shipping air. To assist with accomplishing this new challenge, this paper focuses on gaining efficiencies within the parcel logistics hubs. Specifically, this is achieved by utilizing modular containerization, in the form of PI containers, and pre-sorting, to minimize a parcel's required touches and time spent within the hub. We review the current state-of-the-art sorting techniques as well as the relevant Physical Internet(PI) literature about hyperconnected crossdocking hubs and PI containers. Then we introduce methods for pre-consolidation with modular containers. To finish, we present our experiment using a simulated hub that combines modular containers with pre-consolidation techniques to achieve greater efficiencies with respect to resource utilization and parcel time in hub.*

Keywords: *Physical Internet; Parcel Logistics; Express Parcel Delivery; Hyperconnected Logistics Hub Design; Modular Containerization; Flow Consolidation; Crossdocking; Sortation; Facilities Design; Simulation*

1 Introduction

Heightened competition in the parcel logistics industry by companies such as Amazon, DHL, SF Express and UPS has increased the power of the customer (Bateman et al, 2016). As a result, the current industry trend is towards a broader offering of cost-efficient service products, which allow customers to receive their parcels faster and at more specific, flexible and convenient times. One manifestation of this is customers desiring delivery speed on the order of a day, even a few hours or 30 minutes in certain high-density city centers. However, this trend presents a major challenge for service providers. As discussed in Montreuil (2011) and Savelsbergh and Woensel (2016), current supply chains suffer from inefficiencies highlighted through multiple symptoms such as shipping air, empty travel, and delivery difficulties, causing sub-optimal service performance and unnecessary costs. To stay competitive in the industry, service providers are searching for new ways to meet customer demand while at the same time reducing cost, effort and risks.

This paper focuses on how modular containerization, in the style of Physical Internet (PI) containers (Montreuil et al, 2016), can impact the performance of parcel logistics hubs, with the goal of enabling reduced resources and handling, and a quicker rate of flow through the facility. We propose that if parcels arrive, are pre-sorted by next destination hub, and move through the hub as one large parcel, they will eliminate the sorting and handling required for all the parcels in the grouping. Thus, because the largest cost, with regards to both time and resources, in a parcel logistics hub is the handling and sorting, we aim to show that modular containerization can drastically improve throughput and reduce necessary resources and time.

When packages are designed as Physical Internet packs, these packs can be easily snapped and handled as a single composite pack until their common next destination. This might be some intermediary hub, or yet their final hub near their destination, depending upon what is dynamically most pertinent. Until such packs are readily used, the packages can be consolidated in Physical Internet boxes according to the same concept as above.

In the rest of this paper, we will present our literature review of the current state-of-the-art methods for sorting in parcel logistics hubs, as well as relevant Physical Internet concepts such as PI containers and hyperconnected crossdocking hubs. Then we will introduce the processes of pre-consolidation and how parcels will arrive at the hub in modular containers and the sorting processes they will impact. We will finish with an experiment simulating a parcel logistics hub's performance while receiving varying levels of pre-sorted and consolidated PI containers.

2 Literature Review

In this section, we discuss the relevant literature written about sorting methods, and PI concepts.

2.1 State-of-the-Art Sorting Methods

In parcel logistics hubs, the main processes are the unloading, sorting and loading of parcels. The processes of a general parcel logistics hub are shown in Figure 1).

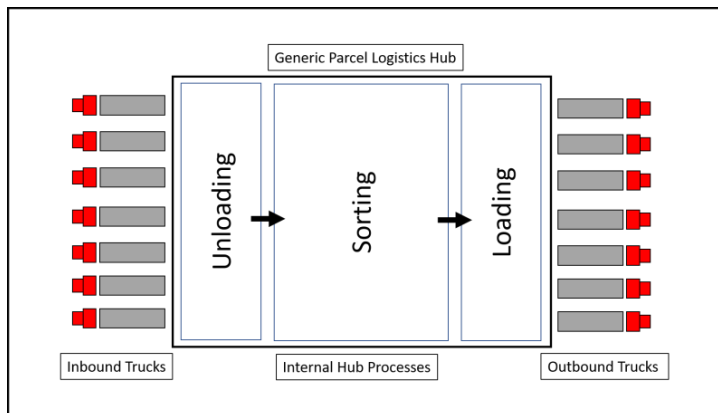

Figure 1: An example of a generic parcel logistics hub

A more in-depth and comprehensive look at the processes and machines is given in Bartholdi and Hackman (2017) and Rushton et al. (2010). They describe the best practices as well as the different types of equipment used in the hubs. Specifically, Rushton et al. (2010), elaborates on the typical sorting machines found in practice. These include the tilt-tray, slide-shoe and cross-belt sorters. In our simulation presented at the end of this paper, we utilize cross-belt sorters.

Through understanding how a hub operates, it is clear that a major role for the hub is to add space-time value to the logistics system in terms of time, cost and risk by facilitating nodal interconnection and flow consolidation across the network. Thus a fundamental design and operational challenge for parcel logistics hubs is for the advantages of additional touches generated by going through hubs to overcome the disadvantages, i.e. that they be considered as high-value performance enablers rather than hurdles. Optimizing parcel logistics hub design and operation has thus, as a fundamental goal, to ensure that the combination of transportation, sorting, storage and handling induced costs, lead times, non-quality issues, and risks over the entire network, from parcels' origins to destinations, results in better financial, service and sustainability performance with the designed hubs than without them.

With regard to this goal, the parcel throughput and sojourn time performance of logistics hubs, balanced with their fixed and variable costs is critical to overall network performance. Bartholdi and Gue (2004) attempt to minimize travel distance, and therefore sojourn time, from door to door across a crossdock by finding the optimal shape of a facility. They find that for small to mid-sized crossdocks, (less than 150 doors), the I-shape is most efficient because it gets maximized use out of its central doors.

Much literature focuses on optimization through load balancing, and unloading and loading scheduling to minimize the makespan of operations. For example, both Haneyah et al. (2014) and Briskorn et al. (2017) focus on scheduling, with the first expanding on the dynamic load-balancing algorithm to analyze performance under different scenarios and system layouts, and the second focuses on comparing a complex scheduling algorithm to general rules of thumb when operating a closed loop, tilt-tray sorter. Again, in a similar topic McWilliams (2009) proposes a dynamic load-balancing algorithm to minimize the time to unload, sort and load a large number of trailers at a much smaller number of docks. This trend in the literature is so prevalent that Clausen (2017) proclaims that “minimizing the makespan and balancing workloads are the main objectives of current works.”

2.2 Physical Internet

Not much literature focuses on preconsolidation as the driver for creating efficiency. However, PI papers provide a strong foundation of concepts that support preconsolidation as a means for optimizing hub performance. Meller et al. (2013), Ballot et al (2013) and Montreuil et al (2012) each discuss a different type of load transfer facility to be implemented in the PI. Meller et al. (2013) proposes a road-road switching yard in which truck drivers arrive at this facility, smartly positioned midway between their respective hubs and switch trailers, thereby continuing the load's progress towards its destination while at the same time keep the drivers closer to their hub facility. Ballot et al (2013) proposes a rail-road crossdocking facility in which rail cars and trucks utilizing physical internet loading and unloading technology can quickly and efficiently transfer loads between each other. And Montreuil et al (2012), proposes a road-road crossdocking hub which most closely mirrors the parcel logistics hubs we consider in this paper. At the proposed facility, trucks arriving with loads encapsulated within modularized PI containers are able to quickly and efficiently unload and load containers thanks to the modular standardization and clicking abilities of the containers. These PI containers are discussed in Gazzard and Montreuil (2015), which presents preliminary designs and necessary features, such as modularity and clickability, in order for the containers to be effective enablers of the Physical Internet.

3 Parcel Logistics Industry as PI Testbed

Having discussed the foundational concepts presented in the PI literature, it is clear that the parcel logistics industry already has beneficial similarities to the Physical Internet. In this section we will focus on the two similarities which have the most bearing on the research in this paper. Both use modular containers, whether they be cardboard boxes, or secure, smart connectable containers. And, they both are comprised of networks of sorting facilities, where the standardized units are transferred between carriers.

3.1 Parcels as PI Containers

According to Physical Internet concepts, the consolidation of parcels is achieved through standard modular containers especially designed to ease hyperconnected logistics (Montreuil 2011). Three types of modular containers, transport, handling and packaging, are exploited. These are called in short pods, boxes and packs, respectively. The functional requirements of such containers are expressed in Montreuil et al (2016). Modular in dimensions and being equipped with snap-fit connectors, containers of a given type can be readily snapped together to create composite containers, as shown in Figure 2). Furthermore, combinations of packs fit readily in boxes, and combinations of boxes fit readily in pods. Handling, sorting and storing equipment are designed to exploit the functionalities of the modular containers, as well as transport, pickup and delivery vehicles.

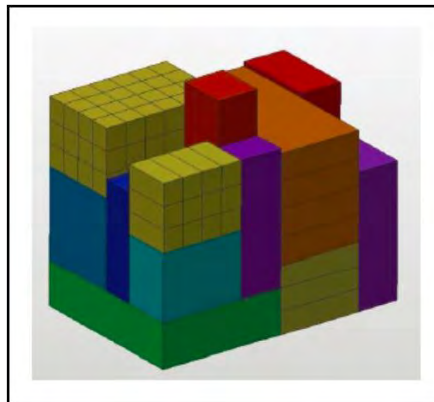

Figure 2: Consolidated Physical Internet Containers (Gazzard and Montreuil. 2015)

The packs correspond essentially to the current parcel packages. They are modular, in the shape of a cube and encapsulate the individual products being transported, yet are additionally adapted to the functional requirements of the Physical Internet. Thus, it is an easy jump to envision packs being transported through a parcel logistics system instead of the cardboard parcels that are used now. They have all the same functionality as a parcel; they can be picked up and moved by workers and forklifts. They can be transported along by conveyors. They can be sorted in any sorting facility. They can be stacked in trucks. And they secure and obscure their contents from other parties.

In much the same way, PI boxes correspond to the current bags and totes used in the parcel industry. Currently, parcel logistics companies group parcels of a similar next destination into a bag which they then use to transport the parcels in. This is the exact function of the PI box, which allows it to be interchanged with the bags in a parcel logistics hub with almost no need for adapting existing equipment and procedures. The PI box also adds convenience to the sorting process, such as being able to pass through the system as a larger pack, but we will discuss that later in Section 4.

Pods are currently not used significantly, except in consolidations in 6 or 12 m cargo containers. Thus, we do not consider them here.

3.2 PI Crossdocking Hubs as Parcel Logistics Network Sorting Facilities

Just as we have considered the parcel and the bag as great surrogates for the implementation of PI containers, due to their similarities and ease of which the containers could be swapped in, we now present the similarities of the parcel logistics hub network to Physical Internet Hyperconnected Hubs Network.

Parcel Logistic hub network is a web of crossdocking hubs where parcels are transferred from one carrier to another on their path from shipper to receiver. As shown above in Figure 1), the basic functions of a parcel logistics hub are loading, sorting, and unloading, with the primary function being the sorting. The hubs receive modular parcels in loaded trucks, unload them, sort the parcels by next destination and whatever other criteria they may have, and then fill new trucks with the sorted loads and send them on their way. These are the exact same basic functions of a PI enabled hyperconnected crossdocking hub. Thus, it makes sense that a parcel logistics hub be used as a real-world test bed for PI crossdocking hub experiments. Figure 3) shows an example of a PI hyperconnected crossdocking hub from Montreuil et al (2012).

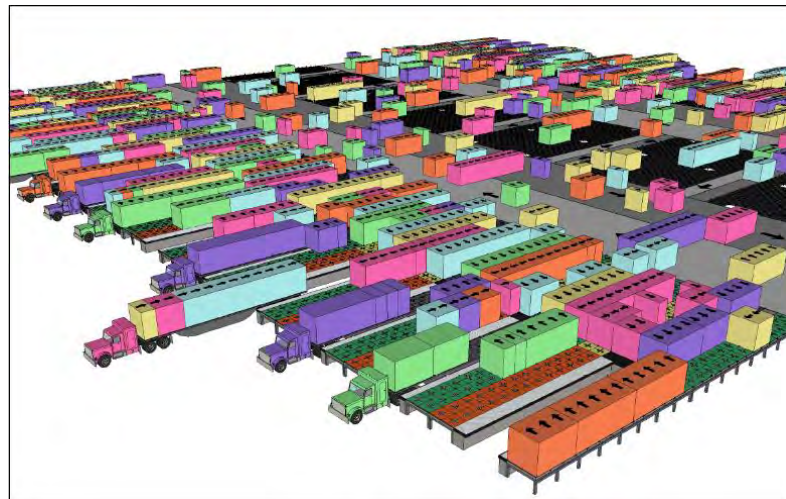

Figure 3: A Rendering of a Hyperconnected Crossdocking Hub (Montreuil et. Al. 2012)

Now that we have shown the similarities of the parcel logistics industry to the Physical Internet, in the next section we will discuss ways to exploit these similarities, through pre-consolidation methods and wave-sorting.

4 Pre-Consolidation Processes

The concept of pre-consolidation is simple to grasp, but can have significant impacts on the performance metrics of a parcel logistics hub. As mentioned in the introduction, pre-consolidation is the method by which parcels with a common future destination are grouped together and treated by the system as one larger parcel until that destination is reached. This common destination might be some intermediary hub on the way to their final destinations, or better yet their final hub near their destination. The grouping depends upon what is dynamically most pertinent.

If executed smartly, the benefit of this consolidation method is clear. In the current parcel logistics industry, it is common for bags of parcels to arrive at an intermediary hub, be emptied, and have all the parcels sorted individually. This is the case even if some of the parcels have common future destinations. In contrast, using the method of pre-consolidation, when N parcels are consolidated, the number of parcels that the intermediary sorting facilities must

handle has been reduced by $(N-1)$. Thus, since handling/sorting costs, specifically in terms of resources and time, are among the greatest costs in a parcel logistics hub, this method has the potential to greatly improve parcel hub efficiency.

This assertion, however, raises the question; “If pre-consolidation is so simple, and can reduce handling/sorting costs, then why is it not in widespread use?”. The answer here is simply that the methods for implementation do not exist. In the current parcel logistics system, using cardboard boxes and bags, it is not an insignificant task to assemble/disassemble groupings of parcels, and it is also not trivial to identify, without emptying the bag, which parcels within the bag should stay consolidated and which should be separated. However, we propose that the PI packs and boxes can solve these issues, and allow for efficient use of pre-consolidation.

4.1 Packs vs. parcels

In the parcel logistics industry, items to be shipped are packaged in cardboard boxes. These boxes offer security, protection and a modular encasing for ease of handling, however, there is no way to easily combine these parcels together to form an aggregate parcel. It is possible to tape them together or pile them into a bag, as is currently done, but this brings up the problem we raised earlier. To deal with any parcel in the bag, you must empty the entire bag to find the parcel you are searching for. PI packs solve these issues. As defined in Gazzard and Montreuil (2015), packs, while also being modular, have the convenient function of being able to be easily clicked together and apart in a matter of seconds. Thus, by quickly snapping one pack to a group of already consolidated packs, you easily form a new aggregate pack which travels through the sorting system simply as a larger parcel.

Another key feature of the PI pack is that it is, smart and connected. For example, they could be RFID enabled. This along with the hyperconnectivity of the Physical Internet, allows you to identify all packs within an aggregate pack simply by having the aggregate moved past a sensor. Then, if the hub management system identifies that you need to detach one of the packs individually, you would just unclick it from the grouping while leaving the rest together. This process of creating and deconstructing an aggregate PI pack is shown in Figure 4).

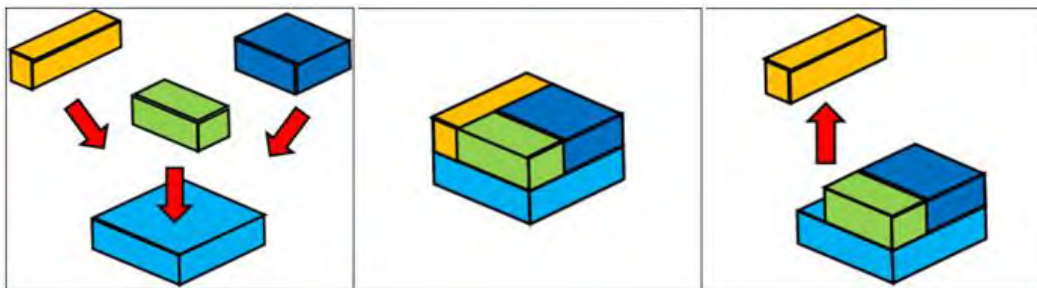

Figure 4: Consolidation and deconstruction of PI packs

4.2 Boxes vs. bags

As discussed before, the standard way that the parcel logistics industry consolidates parcels headed for a similar destination is by placing them in large bags. This is convenient for transporting parcels between hubs, because a group of parcels can all be handled at the same time. However, at the next facility, unless all the parcels in the bag are simply being transshipped, some of the contained parcels will need to be sorted. In order to sort these parcels, the bag must first be untied, all the parcels must be taken out, and then they must be sorted individually and put into new bags. Even if just a few of the parcels need to be switched, the

entire bag must be emptied and re-sorted. This causes a good deal of unnecessary touches, reducing the efficiency and benefit of bagging the parcels in the first place.

In contrast, as defined in Gazzard and Montreuil (2015), PI boxes containing packs which need to be removed, can simply have a panel opened, the desired packs unclicked from the group, and removed. Then, before the panel is reattached, other packs can be consolidated into the box. In this way, all of the packs that are already sorted, stay sorted and do not need to be touched again. As noted above, the PI packs are designed to be smart and connected, so to determine if packs need to be removed from a box, the box can simply pass in front of a scanner and the hub management system will identify the parcels which need removing.

Also, bags offer no structural integrity that assist with transport and handling. PI boxes are conceptually easier to manage because they will flow through the system just as bags do, but also have structural integrity from their modular, cubic shape which allows them to be handled by standardized PI handling equipment as larger packs.

4.3 Necessary Equipment

In order to make pre-consolidation, and thus the efficiencies that go along with it, a reality, it will be necessary to have specialized equipment. The most critical technology is the creation of easily assembled, smart and connected PI containers such as packs and boxes. The concepts in this paper depend on the ability to easily assemble and disassemble parcels, as well as identify the ones needing removal. If this process is too cumbersome, then all the efficiencies gained by handling less parcels, will be lost in the process of assembling the aggregate loads. This is precisely the reason why pre-consolidation is not in wide-spread use today.

The second specialized equipment needed is a visualization system, such as augmented reality goggles, or a station console that a worker can utilize, in conjunction with a sensor technology such as RFID scanners to recognize which parcels need to be removed from the aggregate. The process in which a worker would use this equipment is shown in Figure 5). First the aggregate parcel would arrive via conveyor to the sorting area, passing by an RFID scanner. The scanner would recognize the passing parcels and evaluate them according to their next destination attribute in the hyperconnected facility management system. Any parcel that does not share the same next destination as the group, would be identified for removal. The worker's visualization system would then highlight the identified parcel(s) and the worker would detach them and send them for sorting.

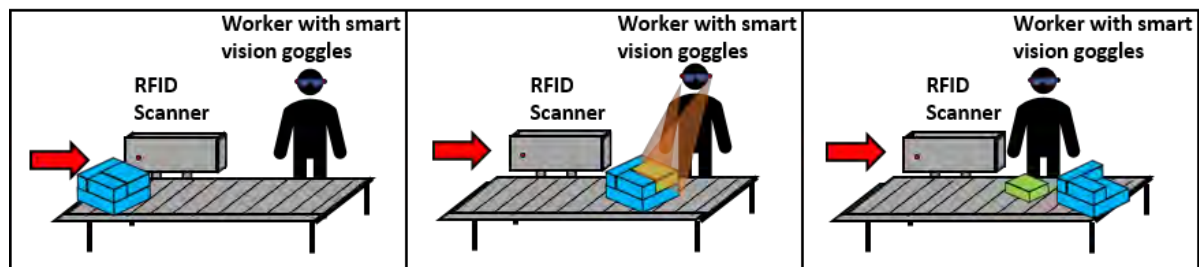

Figure 5: Aggregate parcel is scanned; Smart vision goggles identify parcel to remove; Worker removes identified parcel.

These visualization systems are not too futuristic. In fact, companies already offer pick-by-vision solutions, such as Knapp AG's KiSoft. In this system, smart goggles read QR codes placed throughout the environment and direct a picker through the warehouse by use of visual indicators. With some small adjustments, this solution could be used for identifying PI packs to remove from a group.

Finally, we propose that you would also need a smart hyperconnected hub management system, that could, in real time, receive information about scanned parcels, and then decide which parcels to aggregate and which to disassemble, based on future destination information known in a database. This system would link with the worker's smart vision goggles to help identify parcels as described above

With the above mentioned equipment, we believe that pre-consolidation could become a reality. Most of the necessary technology is available today. The main constraint, is the existence of easily assembled, RFID enabled PI containers such as packs and boxes. In the next section, we explore what the potential savings of pre-consolidation could be, by simulating a parcel logistics hub receiving different levels of consolidated loads.

5 Simulation Experiments

5.1 Experiment Description

In order to evaluate the impact of pre-consolidation on the operations of a parcel logistics hub, we designed a model which simulates a hub receiving, sorting and shipping parcels, which arrive consolidated to varying degrees. Because this topic has not been studied in the literature, this model is meant to provide an exploratory look into the subject and so simplifying assumptions have been made.

Our model generates arriving parcels every hour based on a distribution which causes a minor peak of around 30,000 parcels at noon and a major peak of around 100,000 parcels at 10-11PM. These parcels have weights normally distributed around a mean of 2kg with a standard deviation of 0.5kg. They also have departure deadlines which are normally distributed around 2hrs from their arrival time at the hub, with a standard deviation of 15 minutes. These deadlines are such that if a parcel can arrive at its departure dock by that time, it can be transported to its customer by the delivery date. We assign next destinations to the parcels by randomly drawing them from a list of 80 possibilities. Once the parcels are generated, they are then packed into 17 ton trucks which can carry about 5,140 parcels. These trucks arrive at the hub, unload their parcels at a rate of 2 parcels per worker per second and depart. We assume there are 2 unloaders per dock, and 12 unloading docks. The parcels are then conveyed into the hub at a speed of 1.4 m/s for sorting. If the parcels are larger than 3kg, then they are conveyed right to their loading dock. If the parcels are smaller than 3kg, then they are conveyed to a sorting area where they are sorted by destination, aggregated into larger parcels, and then conveyed to their loading docks. This sorting process is done by workers placing parcels onto cross belt sorting machines which have a rate of 10,000 parcels per hour or 2 parcels a second. At the 80 loading docks the parcels are loaded onto waiting trucks where they leave the system. Considering what we have seen working with a large express parcel company, these assumptions are reasonable for testing consolidation benefits in an environment of current industry practices. A screenshot from our simulation is shown below in Figure 6).

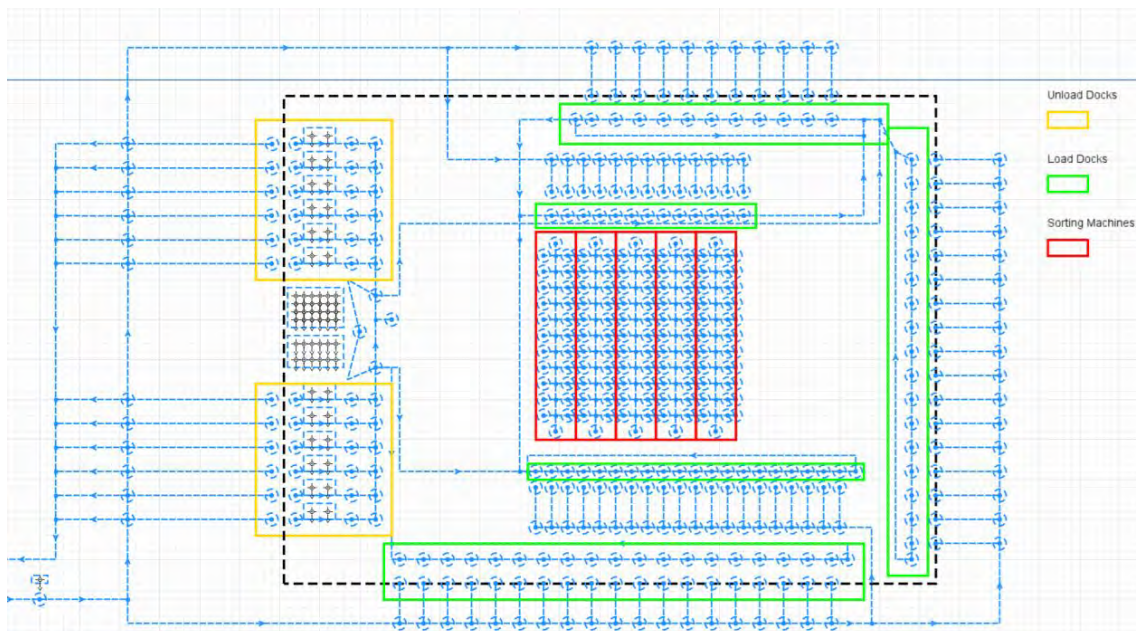

Figure 6: A screenshot of our parcel logistics hub simulation showing unloading docks, loading docks and the sorting area in the center of the hub

We then simulate the same generated parcels entering the hubs with different levels of pre-consolidation and sorting machines. We have 8 scenarios, 4 using 8 sorting machines to sort the differing levels of consolidated parcels, and 4 using 5 sorting machines to sort the same levels of consolidated parcels. In our base case, we simulate every parcel arriving and needing to be sorted individually. This models the current state of the parcel logistics industry. In our second case, we assume 20% of the arriving parcels have been pre-consolidated with other parcels travelling to their same next destination hub. This means that 20% of the parcels have been pre-consolidated into a group of 10 parcels all heading to the same next destination. This aggregate parcel will then pass through the system as one large parcel, as described earlier in our paper. In our third case, we assume 60% of the arriving parcels have been pre-consolidated with other parcels travelling to their same next destination hub. And, in our fourth case, we simulate a scenario where all the arriving parcels on a truck, travelling to the same next destination, have been consolidated with each other, and pass through the hub as one large parcel. In this final case, no individual parcels arrive at the hub. These cases are meant to illustrate the efficiencies gained at different levels of implementation.

We then monitor the performance of the parcel logistics hub by observing the following KPI's:

Average parcel time in hub: This measures the time from when a parcel is placed on an arriving truck, until it is loaded onto its departing truck. This measure takes into account the unloading process, because our facility only has 12 docks, and so during periods of high demand, trucks will need to wait for open docks. However, when parcels are consolidated, the unloading process, which takes 0.5 seconds per parcel, becomes faster because there are less parcels to unload.

Average touches per parcel: This measure indicates how many times on average a parcel was touched by a facility worker. A large parcel that skips the sorting area will be unloaded, scanned, placed on the conveyor to the loading docks, and then loaded, for a total of 4 touches. A small parcel that goes to the sorting area will be unloaded, scanned, placed on the conveyor to the sorting area, transferred to the sorting conveyor, consolidated into a large parcel and then transferred back to the conveyor to the loading docks and then loaded, for a total of 7 touches. Thus this measure gives an idea of how many less touches are required when parcels arrive consolidated.

Number of parcels requiring sorting: This measure indicates how many parcels arrive at the hub and are small enough to need to be sorted in the sorting area. The idea is that as parcels arrive with higher levels of pre-consolidation, less will need to be sent to the sorting area, allowing for less sorting machines to achieve the same service level.

Average time waiting to enter sorting: This measure is also an indication of the burden of parcels on the sorting area of the parcel logistics hub. It is measured from the time a parcel arrives at a sorting machine, until it is loaded onto the crossbelt. If the machine has capacity, this will take 0.5 seconds. If the machine is overutilized, a parcel will have to wait in a queue for a time in addition to the 0.5 second loading time. Thus, having more parcels in the sorting area leads to higher waiting times before sorting.

Percentage of parcels arriving on time: This measure is the percentage of parcels that reach the loading docks before their given deadline. This is used as a measure of performance in parcel logistics hubs to indicate if their setup can perform to a satisfactory level.

5.2 Results

After running the simulation for a full day for each scenario, we obtained the results in the following tables. Table 1 shows the KPI's described above for the 4 scenarios run with 8 machines, and Table 2 shows the KPI's for the 4 scenarios run with 5 machines.

Table 1: Experiment results from scenarios using 8 crossbelt sorters

8 Machines	Scenario 1	Scenario 2	Scenario 3	Scenario 4
Parcel time in hub (Min)	113.713	85.97	59.46	35.442
Parcel touches	6.01	5.97	5.76	4.01
Parcels requiring sorting	348,300	278,755	139,441	121
Time waiting to enter sorting (Sec)	0.96	0.95	0.65	0.51
Percentage On Time	87%	93%	98%	100%

Table 2: Experiment results from scenarios using 5 crossbelt sorters

5 Machines	Scenario 1	Scenario 2	Scenario 3	Scenario 4
Parcel time in hub (Min)	123.67	90.05	59.99	35.02
Parcel touches	6.01	5.97	5.76	4.01
Parcels requiring sorting	348,349	278,791	139,425	119
Time waiting to enter sorting (Sec)	685.03	255.31	5.43	2.17

Percentage On Time	84%	92%	98%	100%
---------------------------	-----	-----	-----	------

From these tables, we observe that for every KPI, as the parcels arrive more consolidated, the metrics improve. For example, in both the 8 machine and 5 machine scenarios, the average parcel time in hub dropped by about half an hour from the base case just by having 20% of arriving parcels be pre-consolidated. We also see a jump from 87% in the base case to 93% in scenario 2 of parcels being sorted on time in the 8 machine scenario. This improvement is even more dramatic in the 5 machine scenario jumping from 84% in the base case to 92% in scenario 2. And with 60% pre-consolidation, 98% of the parcels are sorted on time, for both 5 and 8 machine scenarios. These findings are very promising because even with low levels of pre-consolidation, large efficiencies can be had in terms of fewer machines and workers to achieve the same levels of service.

6 Conclusion

The parcel logistics industry is under large pressure from customers to develop capabilities of delivering faster, on the order of hours, and at more specific times and locations. This customer-centric focus presents challenges for the industry given the current way it is organized. To help meet this challenge, we focus on redesigning the operations and processes of parcel logistics hubs. We see the parcel logistics industry, and the hubs that they operate, as a prime test-bed for applying Physical Internet concepts. Specifically, we believe that by implementing the use of PI containers, such as packs and boxes, we can utilize the concepts of pre-consolidation to drive efficiencies in the sorting processes of the hubs. Thus, reducing cost through labor and equipment requirements.

In this Paper, we first evaluated the current state of the parcel logistics industry. We reviewed the literature on the state-of-the-art methods for improving operations in the parcel logistics industry, but found little that focused on pre-consolidation. From here, we explored the PI literature, specifically focused on modular, connectable containers and consolidation. We then discussed how pre-consolidation would be implemented in the industry and what would be needed to make it a reality. Our research indicates that the main obstacle to implementation is lack of easily consolidated containers such as PI containers. The facility management software, RFID and augmented reality equipment already exists to help workers efficiently deconsolidate and sort aggregate parcels. We then presented a simulation with results that confirmed our hypothesis of the efficiencies that could be gained with pre-consolidation. Our main finding was that in an over-utilized facility, just 20% of parcels arriving consolidated by next destination, could improve service levels by 8%. These gains are significant when considering that they would allow for a reduction in both labor and equipment costs.

We believe that our work will help emphasize the impact that can be had on the parcel logistics industry with the implementation of Physical Internet concepts. We have demonstrated even low levels of pre-consolidation can have significant impacts. We also hope to encourage more researchers to explore this field.

One avenue for future research would be to investigate similar scenarios but with the addition of some aggregate parcels needing to be broken down in the sorting area and then sorted. This will expand the validity of our research to more areas, as well as allow for the discovery of a break-even point in consolidation/deconsolidation time. This point would be the length of time that the consolidation/deconsolidation process would need to beat in order for the extra handling of pre-consolidation to drive better efficiencies than no consolidation at all.

Another avenue for research would be to combine consolidation concepts with time-phased sorting techniques. Both methods have been shown to alleviate stress on the sorting processes of parcel logistics hubs, and combined, they could complement each other very nicely. When there are not enough similar destinations to consolidate parcels, a hub could still time-phase the sorting and vice versa.

We believe this to be a rich field for exploration that will have large impacts on the parcel logistics industry. We also see this as a positive way for encouraging the implementation of Physical Internet concepts in industry.

References

1. Ballot, E., Montreuil, B., Meller, R.D. (2014) “The Physical Internet: The Network of the Logistics Networks”, *La Documentation Française*.
2. Ballot, E., Montreuil, B., Thivierge, C., (2013) “Functional Design of Physical Internet Facilities: A Road-Rail Hub”, *Cirreft*.
3. Bartholdi, J., Hackman, S. *Warehouse & Distribution Science*. Atlanta, Ga, 2016. <http://warehouse-science.com/>. 03 March 2017.
4. Bartholdi, J. J., Gue, K.R. (2004) “The Best Shape for a Crossdock”, *Transportation Science* 38, no. 2, p. 235-244.
5. Bateman, T., Buhler, B., Pharand, A. (2016, September 29) “Adding Value to Parcel Delivery”, Retrieved from https://www.accenture.com/t20170227T024657Z_w_/sg-en/_acnmedia/Accenture/Conversion/Assets/DotCom/Documents/Global/PDF/Dualpub_23/Accenture-Adding-Value-to-Parcel-Delivery.pdf
6. Briskorn, D., Emde, S., Boysen, N. (2017). “Scheduling shipments in closed-loop sortation conveyors”, *Journal of Scheduling* V. 20, Issue 1, pp. 25-42.
7. Clausen, U., Diekmann, D., Potting, M., Schumacher, C. (2017) “Operating Parcel Transshipment Terminals: A Combined Simulation and Optimization Approach”, *Journal of Simulation* 11, no. 1, pp 2-10.
8. Erdem, C., Gue, K.R. (2017) “Optimal Wave Release Times for Order Fulfillment Systems with Deadlines”, *Transportation Science* 51, no. 1, pp 52-66
9. Gazzard, N., Montreuil B. (2015) “A Functional Design for Physical Internet Modular Handling Containers”, *IPIC 2015*
10. Haneyah S.W.A., Schutten J.M.J., Fikse K. (2014) “Throughput Maximization of Parcel Sorter Systems by Scheduling Inbound Containers”, In: *Efficiency and Innovation in Logistics: Proceedings of the International Logistics Science Conference (ILSC) 2013*.
11. Ladier AL, Greenwood A and Alpan G (2015). “Modeling issues when using simulation to test the performance of mathematical programming models under stochastic conditions”, *Proceedings of the European Simulation and Modelling Conference 2015*, Oct 26–28, Leicester, England, pp 117–121.
12. Meller, D., Montreuil, B., Thivierge, C., Montreuil, Z. (2013) “Functional Design of Physical Internet Facilities: A Road-Based Transit Center”, *Cirreft*.
13. McWilliams, D.L. (2009). “A Dynamic Load-Balancing Scheme for the Parcel Hub-Scheduling Problem.” *Computers & Engineering* V. 57, Issue 3, pp. 958-962.
14. Montreuil, B. (2011) “Towards a Physical Internet: Meeting the Global Logistics Sustainability Grand Challenge”, *Logistics Research*, 3(2-3), 71-87.
15. Montreuil, B., Meller, R.D., Thivierge, C. and Montreuil, Z. (2012) “Functional Design of Physical Internet Facilities: A Road-Based Crossdocking Hub”, *MHIA*.
16. Montreuil, B., Ballot, E., Tremblay, W. (2016). “Modular Design of Physical Internet Transport, Handling and Packaging Containers”, *Progress in Material Handling Research: 2014*, Ed. J. Smit, K. Ellis, R. de Koster, S. Lavender, B. Montreuil, M. Ogle, MHI, Charlotte, NC, USA., chapter XVI, 29p.

17. Rushton A, Croucher P and Baker P (2010). “The Handbook of Logistics and Distribution Management”, Kogan Page Publishers, Philadelphia.
18. Savelsbergh, M., Woensel, T. V. (2016). “City Logistics: Challenges and Opportunities”, V. 50, Issue 2, pp. 579-590.
19. Tipping, A., Kauschke, P. (2016) “Shifting Patterns: The Future of the Logistics Industry”, Retrieved from <https://www.pwc.com/sg/en/publications/assets/future-of-the-logistics-industry.pdf>



The Meaning and Importance of True Intermodal Route Planning in the Context of the Physical Internet

Matthias Prandtstetter

AIT Austrian Institute of Technology GmbH, Center for Mobility Systems, Vienna, Austria

matthias.prandtstetter@ait.ac.at

Abstract: *Within this paper, we present a comparison between “presumed” intermodal route planning and true intermodal route planning. We will show that intermodal route planning does not necessarily mean that the obtained route is intermodal but that it is sufficient that under other circumstances (e.g. different traffic situation) an intermodal route would have been suggested. Furthermore, we will point up that the tools for true intermodal route planning are already developed and basically a mind change needs to be achieved. We will also highlight how true intermodal route planning is an essential prerequisite for synchronomodality and therefore for the application of the Physical Internet.*

Keywords: *Intermodal Route Planning, Synchronomodality, Applications of Intermodal Route Planning, Transportation Network Design, Service Network Design, Operational Decisions*

1 Introduction

In recent years, the computational support in planning supply chain processes significantly increased. E.g., a multitude of computer aided planning tools for dispatchers emerged. This is, on the one hand, very welcome as the complexity of the planning tasks steadily increases meaning that human capability of overlooking the whole process reaches its limits. On the other hand, this development bears some pitfalls. E.g., even if a computer aided system is designed in such a way that the final decision (and therefore quality assurance) will be taken by a human, the decision process will be heavily guided by the decision support tool. If the tool itself has conceptual flaws it is therefore very likely that these are adopted during the final decision process. It is therefore essential that (at least) the very fundamental parts of such a decision support tool are reliable and apply the very last state of knowledge. Although the basis of the concept of the Physical Internet (PI) is rather widespread over many disciplines, one essential building block is (sustainable) transportation and therefore plain routing, i.e., path finding in a transportation network. Due to the nature of the PI this transportation network has to be multimodal as otherwise the concept of synchronomodality would not be possible (Prandtstetter et al., 2016; Pfoerster et al., 2017; Putz and Prandtstetter, 2015).

With respect to transportation, PI aims at providing synchronomodal transportation chains. Synchronomodality can hereby be seen as the logical evolution of intermodality towards real-time capability and ad-hoc re-routing (Prandtstetter et al., 2016; Putz and Prandtstetter, 2015). That is, contrary to a classical planning approach, synchronomodality builds upon the possibility to re-plan transportation chains “on the fly” based on current traffic and/or order situations and incidents. For this online re-planning process, it is essential to have *true* intermodal route planning tools available. With *true* intermodal route planning we refer to a planning process which consists of three building blocks:

- **indicating optional modes of transportation vs. premature mode choice**

In our understanding (and contrary to state-of-the-art planning tools), the actual mode choice should be a well-educated decision, meaning that the person in charge of transport planning is not selecting the main outline of the supply chain (e.g. truck-train-truck). This

person only defines which modes of transportation are theoretically possible (e.g. truck, train, ship, but not plane).

- **automatic vs. predefined selection of transshipment points**

Analogously to the selection of modes of transportation, the person in charge of transport planning should not preselect the points of transshipment (e.g., port of X). In best case, this person should be able to specify some preferences (e.g., at port of X we get a discount of 10%, or at port of Y we had bad experiences).

- **generation of a set of promising route options**

Based on the two inputs described above, the route planning tool has to generate not only one optimal route but a set of (almost) equally good routes. E.g., one route might be faster while the other one might be cheaper. The final decision can then be left to the dispatcher. Please be aware, that the best route might be unimodal. Nevertheless, the planning process is intermodal.

It is, however, quite interesting with respect to (true) intermodal route planning that strong parallels between freight transportation and passenger transportation exist (cf. Prandtstetter et al., 2018). Even more, we claim that the same methods used for passenger transportation can be directly applied for freight transportation. However, we also claim that the state-of-the-art approaches are not capable of providing true intermodality.

The remainder of the paper is organized as follows: First, we give a definition of true intermodality followed by a short presentation of algorithmic solution approaches in Section 3. Section 4 will then show application areas and the therewith related impacts. Conclusions will end up the paper.

2 Definition of True Intermodality

Basically, there are a lot of existing interpretations when talking about multimodal, comodal or intermodal routes. This “Babylonian language confusion” is partially based on the fact, that there are severe differences in wording with respect to passenger and freight transportation. On the other hand, this confusion is based on the similarity in meaning (Prandtstetter et al, 2016). For example, for passenger transportation an intermodal route involves more than one (i.e. at least two) different modes of transportation (MOTs) while this characteristic (more than two MOTs) refers to multimodal routes in freight transportation. Intermodal freight routes are, however, multimodal freight routes with the additional characteristic that only one loading unit (e.g. container) is utilized throughout the whole transport. For the sake of readability, we will use the wording intermodal throughout the rest of this paper in its original meaning for passenger transportation. This meaning especially applies with respect to applications in the context of the PI since for the underlying concept of synchronomodality the requirement of the same loading unit must be softened (cf. Prandtstetter et al., 2016; Putz and Prandtstetter, 2015).

When talking about true intermodality, we have to discuss the difference between

- the input for route planning,
- the actual route planning process (including the obtained result), and
- the actual traveled route.

2.1 Input for Intermodal Route Planning

When having a closer look on state-of-the-art route planning processes, we easily see that a common input format is as follows:

- **the origin and destination of the route**

Obviously, when planning a trip, it is necessary to specify at which location the trip should start and at which location the trip should end.

- **the departure time or arrival time of the route**

Modern route planning services incorporate not only plain transport network data (e.g. roads, or train schedules) but also rely on some real-time (or estimated) traffic data (e.g. current travel times, or delays) during route computation. Obviously, it is necessary to have some information about the departure and/or arrival time since otherwise an estimation would not be possible. There are, however, some services which lack this type of functionality (e.g. some route planning services for hiking or other application areas where either the data source is not accessible or no meaningful data exists).

- **the involved modes of transportation**

Since intermodal route planning is addressed, it is necessary that more than one MOT is specified to be used along the planned route. To the best of our knowledge, state-of-the-art approaches for intermodal routing do not allow to freely select different MOTs but they have to select some (typical) combinations like “bike-and-ride” or “park-and-ride”. In some situations, public transport routing is also referred to as intermodal since walking and some public transport vehicles are involved. However, when arguing like that, almost all routes are intermodal since (at least for passenger transportation) all routes start and end with walking. The same argumentation applies to freight transportation where, even if only truck transportation is involved, goods have to be loaded/unloaded into/from the trucks.

- **the intermediate transition points**

For some services, especially in combination with “park-and-ride” features, it is possible (or necessary) to specify a specific transition station. Although this might be handy when your car is already parked at such a station and you want to plan your return journey, it is rather unhandy to specify a transition station, when you have no further information (e.g. time schedule of public transportation, or amount of available car parking slots). Obviously, the same applies in freight transportation, where the intermediate points are typically hubs used for changing from one mode of transportation to another one. Why do shippers in e.g. Austria have to select whether a container to USA have to be transported via Hamburg, Germany, or Rotterdam, The Netherlands? In fact, this decision is crucial for the performance of the trip (e.g. costs, or travel time) but cannot be made if not enough information is available.

Although this parts of input are common and to some extent are obvious, we demand that for future services, the input has to be changed to the following input:

- **the origin and destination**

With respect to this input, we see no meaning in changing something here.

- **the departure or arrival time of the route**

Again, we see no further meaning in changing something here. If, at all, we suggest that this option is always available (even in cases where the impacts of changing the departure/arrival time might be neglectable).

- **the involved modes of transportation**

Here, we propose that users are able to freely specify the desired MOTs. A very attractive design is provided by the journey planner of Travel York (2018). Here, the user can

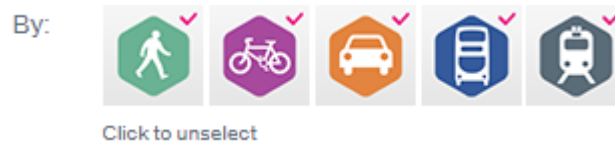

Figure 1 MOTs selection as implemented by Travel York (2018).

arbitrarily select a set of possible MOTs, see also Figure 1. (Unfortunately, the route planning itself is then unimodal, meaning that for each selected MOT one route using just this MOT is generated.)

- **the intermediate transition points**

Instead of specifying a fixed transition point, we suggest that it is possible to specify the location of e.g. the car or bike (which might be at home or work or some other arbitrarily chosen position). One could think further that in addition a set of possible transition points is selected by e.g. stating that a park-and-ride facility from company A is ok but one from company B is not (e.g. since a monthly parking ticket for company A is already paid). Obviously, the same is true for transition points in freight transportation. Some hubs might be preferred due to special agreements or some legal frameworks. It is, however, necessary to think about the proper user (or data) interface.

As can be seen, the differences between the state-of-the-art and proposed input are not too large. At the same time, as will be further explained in the next sessions, these differences build the basis for a flexible route planning.

2.2 The Intermodal Route Planning Process

After having the input request, the next step is to plan the actual route. Here, again, differences can be observed between the common available state-of-the-art services and the in our view necessary approach:

- **integration of selected modes of transportation**

There are two common approaches for route planning: The first one, as applied by Travel York (2018), is to let the user pre-select possible modes of transportation but do no intermodal route planning. That is, even if a set of routes is provided each route incorporates only one mode of transportation. In some cases, and we refer to the well-known Google Maps route planner for an example, it is only possible to select one MOT. Obviously, the routes are incorporating just this one MOT.

The second state-of-the-art approach is to incorporate *all* selected MOTs into one route. If this approach is applied, the user interface normally restricts the number of freely selectable MOTs or limits the selection even to pre-defined clusters, e.g. park-and-ride. Unfortunately, the results obtained using this approach can be rather poor. E.g., an intermodal park-and-ride trip might then consist of taking the car for a few meters and then switch to public transportation, cf. also Prandtstetter et al. (2018) for examples.

We propose, however, to allow flexibility: This means, that even though a user pre-selected a set of MOTs, this selection should be understood as “this is possible but not necessary”. This means, that all or also just some of the pre-defined MOTs are incorporated in the resulting route. Even more, the resulting route might then comprise only one MOT. We therefore stress here, that intermodal route planning must not mean coming up with an intermodal route. It only means that intermodal options are compared against unimodal options. The best fitting route (independent of the number of MOTs involved) is then returned.

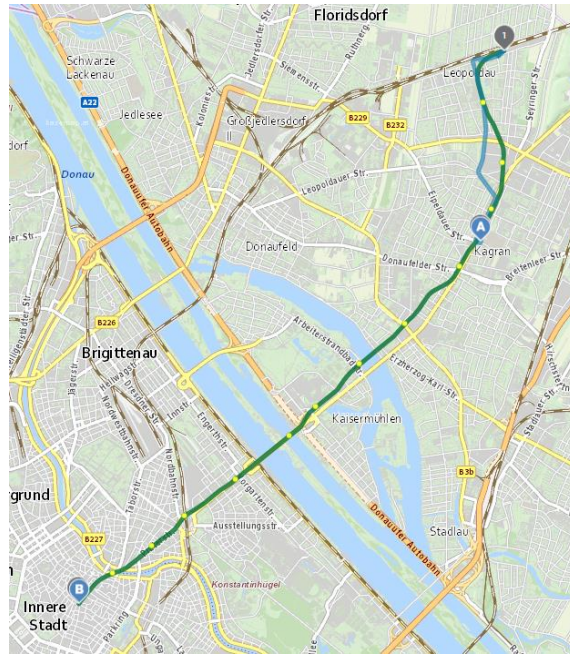

Figure 2 A forced intermodal route with semi-fixed transition point.

- **integration of transition points**

The integration of transition points is strongly connected to the incorporation of different MOTs. In case the user interface (or logic of the route planner) requires that a transition point is pre-defined, it is obvious that state-of-the-art approaches take this transition point into account. At the same time, if a MOT combination is pre-defined (e.g. park-and-ride) it is obvious that a fitting transition point has to be selected. This might result in some weird routes as shown in Figure 2. Instead of suggesting a pure public transportation route, a bike-and-ride route is suggested from point A to point B due to user pre-selection. Unfortunately, the closest (or best suited) bike storage facility is in the opposite direction than the originally planned trip. This results in a public transportation route passing by the original departure location (which, by the way, is a public transportation station as well). The arising problem with this example is that beside the fact that intermodality is forced, also the transition point is forced to have specific characteristics (bike storage facility).

We stress that future intermodal route planning service must be flexible enough to decide that among the possible transition points none is well located such that an intermodal route is not meaningful at all.

- **generation of alternatives**

Some route planners provide the possibility to obtain route alternatives, that is, routes which differ either in departure time or directions. One good example is Google Maps (Google, 2018) which provides alternatives (especially for the road-bound MOTs car, bike, walking). Unfortunately, the alternatives are not always meaningful. E.g., as shown in Figure 3, one of the two alternatives for a trip from Vienna to Graz would take additional 40min of travel time (on a total travel time of approx. 2h). In addition, alternatives are limited to the very same MOT only.

We suggest, however, that route alternatives should be computed based on the pre-defined set of possible MOTs. That is, that the alternatives provided might differ in the actual route (e.g. taking another road) but also in the MOTs incorporated.

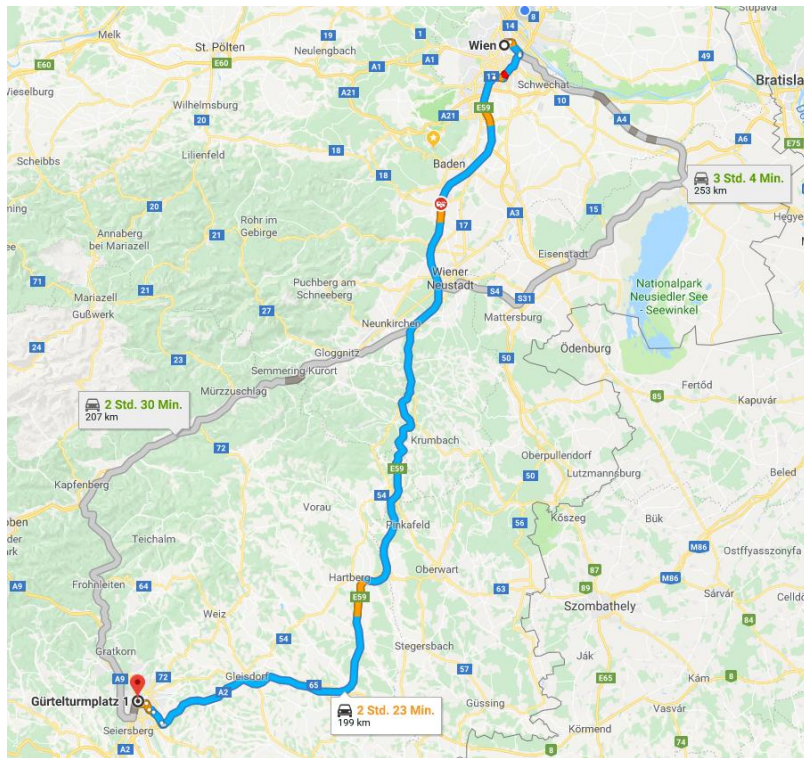

Figure 3 Alternatives as provided by Google Maps (Google, 2018).

2.3 The Intermodal Route Journey

The third step with respect to intermodal routing is the actual trip. Obviously, this is strongly dependent on the traveler and not so much dependent on the used journey planning device. We want, however, highlight that an intermodal route planning does not require that the trip itself is then intermodal too. There are various reasons which might be justified by some external parameters (e.g. availability of some resources) or by some internal parameters (e.g. custom).

However, and more important, especially in the context of the PI, we note that real-time re-planning of routes is one of the crucial factors of synchronomodality. Therefore, it might happen that even though the route was perfectly planned to be intermodal some incidents (or additional orders) influence the re-planning such that a unimodal route is the then best option.

3 Algorithmic Solution Approaches

Within this section, we give a short overview on how intermodal route planning can be performed. Again, we highlight the differences of state-of-the-art route planners in comparison to our proposed true intermodal route planning approach.

3.1 Routing Network

Planning intermodal routes is not an easy task since compared to unimodal route planning a significant additional amount of input data has to be processed. This includes, among others, map data, time schedules, and availabilities of transition points (e.g. capacities in parking lots). Beside the fact that it is rather complex to have always up-to-date information, this multitude of data also brings in a multitude of options (e.g. instead of deciding only if to turn left or right at a crossing, it is for intermodal routing also an option the park the car and switch to walking, bike or public transport). Therefore, a common state-of-the-art approach is to partition the routing problem into different layers. Each of these layers is responsible for one MOT and connections between the layers are existing only at pre-defined locations (Partusch, 2018).

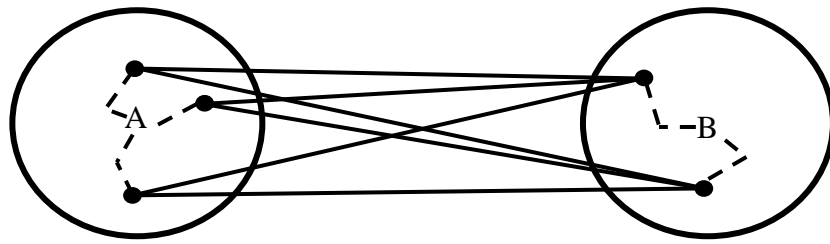

Figure 4 Schematic graph of classical "intermodal" route planning.

Depending on the flexibility of the system, these locations are either static or route request dependent. However, a classical (intermodal) routing request (for e.g. walking and public transport) is then answered by first finding all public transport stations in the proximity of the departure location. In addition, all public transportation in the proximity of the destination location are searched. Then, (unimodal) routes from all possible starting public transport stations to all possible ending public transport stations are calculated. Merged with the walks to/from the stations, the best route is chosen, cf. also Figure 4.

We propose, however, to employ the approach presented in (Prandtstetter et al., 2013) where a multi-layered network graph is constructed with each layer representing a MOT. Then, among all possible interchanging points a (virtual) connection is created (which can be even weighted according to some costs – e.g. time for transition). It is then very easy and straightforward to apply a classical shortest path algorithm like Dijkstra's algorithm (Dijkstra, 1959). Beside the fact, that this approach is rather flexible (e.g. the weights of the transition edges can be adjusted according to traveler preferences) this approach also guarantees to come up with the optimal, i.e. the best possible, route. In case, the best route is intermodal, the appropriate MOTs are involved. However, if the optimal route is unimodal this approach can also provide this unimodal route.

3.2 Providing Route Alternatives

When talking about finding alternatives, we have to admit that different approaches exist which cannot all be listed here. We have to highlight that even the definition of an alternative is not that easy and is a research field on its own (e.g. Dees, 2010).

One advantage of the modelling approach presented in (Prandtstetter et al., 2013) is that it is very easy to assign to each MOT an individual weighting factor. While the original optimization problem is to find the fastest route throughout the transportation network, the weighted optimization problem is to find a route which minimizes the weighted travel time.

We refer to Figure 5 for an example of the weighted route optimization problem. Here, we see a small graph representing the walking layer below the dashed line and the bike layer above the dashed line. Numbers indicate the travel time needed when traveling along the edges. Obviously, the fastest route to get from left to right is to first bike and then switch to walking (with a total travel time of 8). However, in case the biking layer is weighted by 2 (indicated in the Figure by *2), we obtain the fastest route by walking (travel time 10) since the travel time for pure biking changed to 18 and the travel time of the previously best route changed to a total travel time of 11. We refer to (Prandtstetter et al., 2018) for further examples.

The advantage of this approach is that personal preferences can be incorporated in the routing. For example, if a person is able to walk but prefers biking, then the (relative) weight for walking and bike should be accordingly adjusted. E.g., a weighting of a factor 2 as in the above example, indicates that one minute of travel time walking is perceived as two minutes taking the bike. Since appropriately setting these weights is rather complex, we suggest that the same route

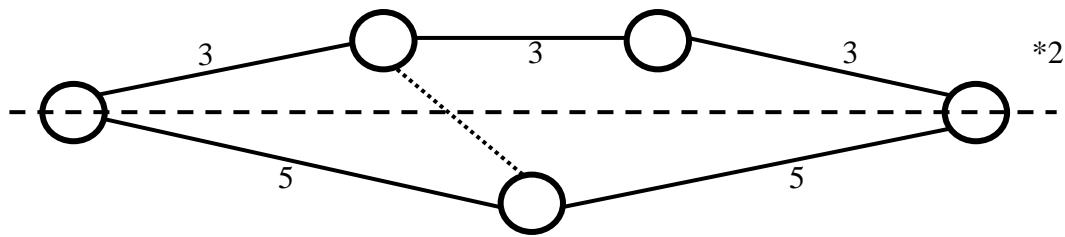

Figure 5 Exemplary graph with nodes above the dashed line representing the bike layer and graphs below the line representing the walking layer. Number given at the edges represent the actual travel time. The dotted line represents a possible transitions from walking to bike (or vice versa).

request should be answered with different (rationally chosen) weightings such that a set of route alternatives is generated. This set is then presented to the user who has to decide which route is preferred.

One can go even one step further in that sense that not only optimization with respect to travel time is possible. Other optimization goals could be costs or environmental key performance indicators like CO₂ emissions. Furthermore, weighted sums of these (and others) goals can be used as main objective function in finding the best route.

4 Application Areas in the Context of Freight Transportation

While the above-mentioned thoughts and results are mainly focusing on passenger transportation, we want to (once more) highlight that the route planning process for freight transportation is quite similar. In some situations, the parameters or inputs differ (e.g. transition points will most probably be selected on capacity, equipment and costs) but due to the flexibility of the presented approach the same planning algorithms can then be applied. While intermodal route planning is essential for passenger mobility of the future, this section focuses on other application areas arising mainly in freight transportation.

4.1 Promotion of sustainable modes of transportation

Having true intermodal route planning is of interest in application areas where sustainable modes of transportation (mainly train and inland navigation) shall be incorporated or even more be promoted. For that purpose, often, decision makers have few (if any) experiences meaning that they do not have the “gut feeling” whether it is a clever decision to switch to train/vessel or not. Therefore, handy and flexible planning tools incorporated in a smart designed decision support tool are necessary. Then, the decision maker can easily decide which option is (from an economical or ecological point of view) the best option. Important is, however, that true choice is only possible if (good) alternatives are presented. That means that forced intermodal routes which incorporate a lot of assumptions (e.g. pre-selection of MOTs, pre-selection of transition points, etc.) which most likely will not result in optimal (or at least good) alternatives will shake the decision maker’s confidence in applicability of intermodal routes resulting in avoidance instead of joining the forces.

4.2 Transport Network and Service Network Design

Another important application area is transport network design and service network design. In these areas, the main goal is to plan the transportation network and services to be performed on that network. Obviously, the easiest (but also the worst with respect to sustainability) way would be to plan future transportation infrastructure only for road transportation (i.e., passenger cars and trucks). However, it turns out that (beside ecological sustainability) pure road transportation is also not sustainable with respect to economic goals. Therefore, an intermodal transport network is necessary. In addition, (intermodal) services on the network have to be planned. One major commonly applied step in planning these transportation and service

networks is to simulate future utilization. Even though, if the future utilization would be intermodal due to manual planning, it is essential to have true intermodal route planning tools during that simulation phase.

4.3 Automation of Re-Planning

When talking about the PI, it is normally assumed that bundling and modal shifts are incorporated in freight transportation. Even more, it is anticipated that real-time re-plannings are incorporated. However, real-time re-planning can only be applied if automatic tools are available supporting modal switches as otherwise a re-planning would either take too much time or would not result in alternatives.

4.4 System-Aware Route Planning

The finally presented application area which is also closely related to the application within the PI, is the application in the system-aware context. While the PI context strongly focuses on the transportation process itself (real-time switching between MOTs, booking of PI service at PI hubs, etc.), the system-aware context focuses on the transportation system as a whole including all surroundings which are, among others, other traffic participants (freight and/or passengers), residents, communities, municipalities, schools, hospitals, etc. When aiming at a system optimum it is sometimes better to forego low-hanging fruits with respect to one individual trip and allow detours or delays such that other, maybe more important, services can be performed in superior quality. It is important that, however, these other services do not necessarily be related to transportation. Sometimes improving air quality for residents is more important than supplying a supermarket with the latest deliveries, just to mention one of thousands of examples. This includes, however, also a mind shift at the customers.

5 Conclusions

In this paper, we presented an overview on state-of-the-art “intermodal” routing approaches and suggested what to do in order to come up with *true* intermodal route planning. We refer by true intermodal route planning to trip planning that is neither forced to be intermodal nor constrained by assumptions which are made due to lack of knowledge or complexity. Further, we showed how to model the basic intermodal route planning problem such that well-known and efficient routing algorithms can be applied while at the same time flexibility (and therewith optimality) are introduced. We also showed that even though many of these considerations are originated in passenger transportation they are directly applicable in the freight transportation context. Even more, we showed that no changes are necessary for application in freight transportation.

We have, however, to conclude that even though methods are available and ready there is still a strong perception that intermodal route planning means that an intermodal route is performed. We have to stress that planning of routes and traveling are two independent steps. Even more, the result of the intermodal route planning might be a unimodal route. Still the process can be called intermodal route planning as long as an intermodal route could have been generated under different circumstances (e.g. different traffic situation) and intermodality is not forced at any time. We have the feeling that a lot of dissemination and persuasion work has to be done in order to come up with a true intermodal route planning process building the basis for synchromodality and therefore for the PI.

6 Acknowledgements

This work partially received funding from the European Union's Horizon 2020 research and innovation programme under grant agreement No 636160-2 (OPTIMUM). Further, this work partially received funding from the Austrian Federal Ministry of Transport, Innovation and Technology's (bmvit) research and innovation programme "Mobilität der Zukunft" under grant agreement No 859115 (inned). We would like to thank our collaborators in these and various other projects which laid a crucial basis for this work during stimulating discussions.



References

- AnachB.at (2018): *Routenplaner*. www.anachb.at. Last accessed May 2018.
- Dees J., Geisberger R., Sanders P., Bader R. (2010): *Defining and Computing Alternative Routes in Road Networks*. Technical Report. Karlsruhe Institute of Technology. pp. 1-10.
- Dijkstra E.W. (1959): *A note on two problems in connexion with graphs*. Numerische Mathematik, vol.1. pp. 269-271.
- European Commission (2006): *Keep Europe moving – Sustainable mobility for our continent – Mid-term review of the European Commission's 2001 Transport White Paper*. COM(2006)/0314/final.
- Google (2018). *Google Maps*. www.google.com/maps. Last accessed May 2018.
- Partusch A. (2018): *Integration of vehicle sharing systems into an intermodal journey planner*. In: Proceedings of 7th Transport Research Arena TRA 2018.
- Pfoser S., Putz L.-M., Schauer O., Prandtstetter M. (2017): *Facilitating synchromodal transport through interconnected, modular and intelligent transport units*. In: Proceedings of EurOMA 2017. Paper-No 42564. pp. 1-9.
- Prandtstetter M., Putz L., Pfoser S., Haller A., Lenz G., Ponweiser W. (2016): *An Introduction to Synchromodal Networks in Austria*. In: Tagungsband 10. Forschungsforum der österreichischen Fachhochschulen 2016. pp. 1-6.
- Prandtstetter M., Seragiotto C. (2017): *Towards System-Optimal Routes*. In: Extended Abstracts to the Sixteenth International Conference on Computer Aided Systems Theory (EUROCAST 2017).
- Prandtstetter M., Seragiotto C., Straub M., Magoutas B., Bothos E., Bradesko L. (2018): *Providing Intermodal Route Alternatives*. In: Proceedings of 7th Transport Research Arena TRA 2018. Paper No 10526.
- Prandtstetter M., Straub M., Puchinger J. (2013): *On the Way to a Multi-Modal Energy-Efficient Route*. In: Industrial Electronics Society, IECON 2013 – 39th Annual Conference of the IEEE. pp. 4779-4784.
- Putz L.-M., Prandtstetter M. (2015): *Synchromodal Networks*. Presentation at Logistik Future Lab – Österreichischer Logistik Tag 2015. Linz.
- Travel York (2018): *Journey Planner*. https://www.itravelyork.info/planner/. Last accessed May 2018.
- UN/ECE, European Conference of Ministers of Transport, European Commission (2001): *Terminology on combined transport*.



Trust in a multi-tenant, logistics, data sharing infrastructure: Opportunities for blockchain technology

Simon Dalmolen^{1,2}, Harrie Bastiaansen¹, Hans Moonen^{2,3}, Wout Hofman¹, Matthijs Punter¹,
Erik Cornelisse³

1. TNO, The Hague, The Netherlands
2. Universiteit Twente, Enschede, The Netherlands
3. CGI, Rotterdam, The Netherlands

Corresponding author: S.Dalmolen@utwente.nl

Abstract: *In support of the trend towards ever more complex supply chain collaboration for the Physical Internet, a trusted, multi-tenant (and interoperable) data sharing infrastructure has to be enabled. Trust is a condition sine qua non organizations may not be prepared to share potentially competitive sensitive information. As such, trust has to be an essential design aspect for any multi-tenant data sharing infrastructure for the data sharing stakeholders*

To overcome the challenges for trusted data sharing, various reference architectures for a trusted, multi-tenant, data sharing infrastructure are being developed. As such, the Industrial Data Space (IDS) initiative is currently gaining attention. It's based on the architectural principles of keeping the data owner in control over his data and keeping data, data processing and data distribution at the source. Its reference architecture is strongly grounded on a role / stakeholder model for the intermediary trusted roles to enable peer-to-peer data sharing over a controlled and trusted connector infrastructure.

The intermediary trusted roles may contain and process meta-data on the data sources, the data transactions and/or on the identities of the parties involved in the data sharing. This paper focuses on the role of blockchain technology for improving trust levels for such intermediary trusted roles.

Keywords: *Supply Chain Collaboration, Multi-Tenant, Trust, Data Sharing, Blockchain, Traceability, Enterprise Architecture*

1 Introduction

The world is increasingly becoming a networked society. To adapt to changing market dynamics, firms take a number of strategic actions. For one, a shift may be observed from companies optimizing their internal business processes into a more collaborative focus in which they focus on optimizing the supply chain as whole. In turn, this leads to organizations shifting from a strategy of competitiveness to a more benevolent strategy (Crujssen 2006). Consequently, organizations are working together to serve customers through mutually dependent and co-operative supply chains via coordination and collaboration. This not only holds for organizations operating within the same sector, but ever more also for organizations operating in different sectors of society, leading to more complex, multi-tenant, supply chains. Improving the agility and flexibility of (supply) chain collaboration offers potentially major benefits but also poses real challenges, both from an organizational and a technical/IT perspective (Luftman, Lyytinen, and ben Zvi 2017).

For the logistics sector and the Physical Internet, the benefits and challenges for enhanced (supply) chain collaboration is illustrated by means of the potential opportunities it provides for sustainability and CO₂ reduction, two of the major challenges for the next decades. Figures of the COP21 in Paris (2016) show that logistics represents 30% of all greenhouse gas emissions, 32% of energy consumption and 94% of all oil import of the Union. From the long-distance perspective, Eurostat surveys estimate that 24% of good vehicles in the EU are running empty and the average loading of the rest is 57% giving an overall efficiency: of 43%. Flow imbalances can explain only half of this loss. The efficiency improvement opportunity is estimated as €160 billion and 1.3% of EU27 CO₂ footprint. Reported load factors in delivery vehicles in cities (e.g. 38% for vans in London¹⁵) show even a higher opportunity (European Commission n.d.).

The latter report has various recommendations to increase sustainability of logistics, like fully available and visible intermodal transport services, resilient logistics networks, seamless transshipment, ‘smart’ hubs, and seamless information exchange in end-to-end logistics by participation of SMEs (Small and Medium sized Enterprises), public administrations and all other stakeholders in transport and logistics networks. Data sharing between stakeholders is at the core of improved collaborative decision making and planning. As such, the topic of trusted and seamless information sharing is expected to be boosted by the Digital Transport and Logistics Forum (DTLF).

As this logistics illustrative case indicates, there is a clear business advantage for stakeholders in the supply chain to share operational data in jointly optimizing the efficiency of the transport processes. However, it also gives rise to new challenges:

- *Trusted data sharing:* To reap the indicated benefits of exchanging data, operational data which may be valuable and business-sensitive has to be shared with stakeholders that could potentially be competitors. A trustworthy infrastructure based on solid agreements and contracts and a technical secure data sharing infrastructure are a prerequisite for convincing stakeholders to exchange such data, i.e. an interoperable, multi-tenant, trusted data sharing infrastructure.
- *Data provider/owner in control:* The ability to access information more easily doesn’t mean that all information will be available for everybody. Business requirements still require a solid authorization mechanism to protect competitive information or against criminal intentions. A direct consequence is the need for an adequate usage and access control capability, with the data provider / owner in control. It is noted that even in case

the data is publicly available, authentication is still required to reduce misbehavior and malicious activities.

- *Semantic interoperability*: Organizations have implemented different technological solutions to achieve their specific goals. Therefore, sharing data to achieve the collaboration supply chain benefits may require major integration efforts to achieve semantic interoperability and increased accessibility of data based on strict authorization control. The integration can be realized on a bilateral implementation between individual organizations. Traditionally, only large companies could afford to implement dedicated gateways to enable their ERP systems to exchange information with each other. A next step is the dynamic configuration of communities to exchange information efficiently and effectively (Dalmolen et al. 2015; Dalmolen, S, Moonen, H M, and Cornelisse, E 2012). However, the need arises for a more flexible, interoperable and trusted way of sharing data between the connecting systems of different stakeholders to realize interconnectivity in a matter of days instead of development projects of months.

Reference architectures for trusted data sharing are currently being developed. (Trusted Computing Group 2013), (Dalmolen et al. 2015), (Boris Otto et al. 2016). In the mean-time, new technologies are emerging and maturing that will have impact on how trusted data sharing and their (reference) architectures are being developed and implemented. As such, this paper considers the potential role that emerging block chain technologies may fulfill in realizing the reference architecture, especially by circumventing the need for centralized trusted roles (with their potentially added vulnerabilities) in the reference architecture.

This paper has the following structure: The following section (Section 2), describes the IDS reference architecture for realizing a multi-tenant, trusted data sharing infrastructure that forms the basis in this paper on the considerations for deploying emerging blockchain technology. Subsequently, Chapter 3 gives a short elaboration of the potential benefits of blockchain technology. Chapter 4 elaborates this in the requirement and options that these blockchain technologies may provide for the actual implementation of the intermediary trusted roles in the IDS reference architecture for the multi-tenant, trusted data sharing infrastructure: the Identity Provider, the Clearing House and the Broker Service Provider. The concluding chapter (Chapter 5) presents the conclusions, the topics for discussion and future work.

2 A multi-tenant, trusted, data sharing infrastructure: reference architecture

The reference architecture that forms the basis of the considerations in this paper is the Industrial Data Space (IDS) reference architecture as it is currently gaining major international traction for realizing a multi-tenant, trusted data sharing infrastructure (Boris Otto et al. 2016). The IDS reference architecture can be considered an architectural elaboration of the Trusted Multi-Tenant Infrastructure (Trusted Computing Group 2013). Figure 1 depicts the main roles and the functions they provide, as part of the IDS reference architecture.

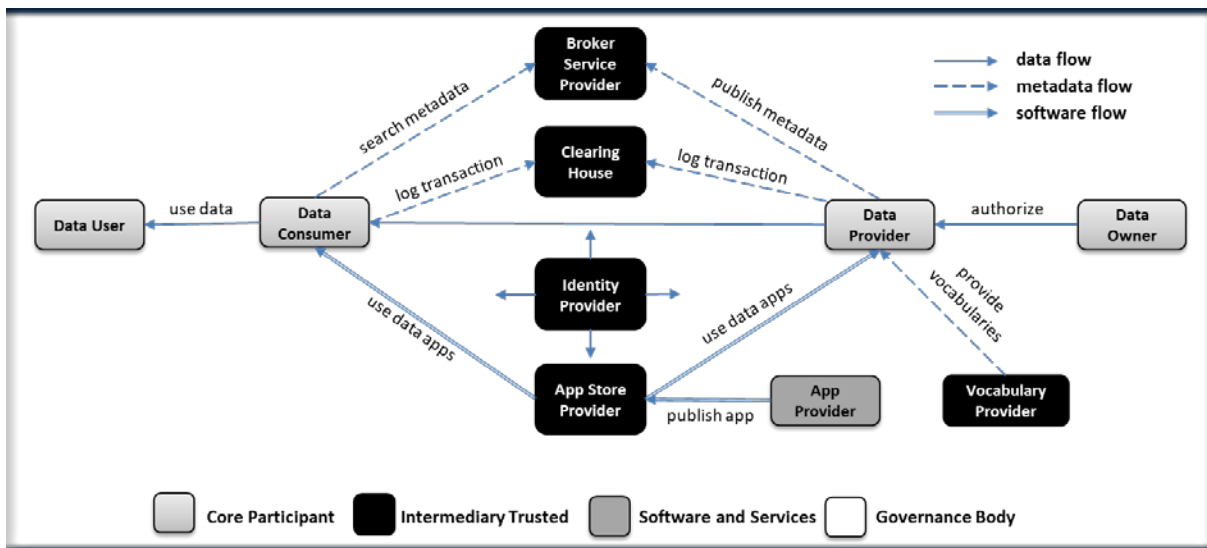

Figure 1: Roles in the IDS reference architecture (Boris Otto et al. 2016).

The roles in the IDS reference architecture as depicted in the figure can be assigned to one of four categories (Boris Otto et al. 2016):

- *Core Participant*. Core Participants are involved and required every time data is exchanged in IDS.
- *Intermediary*. Intermediaries act as trusted entities. Only trusted organizations should assume these roles. They add value for participants in IDS by establishing trust and providing metadata.
- *Software and Services*. This category comprises IT companies providing software and/or services to the participants of the IDS, e.g., in a software-as-a-service model.
- *Governance Body*. IDS is governed by the Certification Body. They ensure that only compliant organizations may participate in this trusted business ecosystem.

The IDS reference architecture is aimed at enabling the trusted sharing of (primary, sensitive) data between ‘Core Participant Roles’. This is done on a peer-to-peer basis between their trusted connectors. No storage of this primary data occurs within the IDS infrastructure. As such, the exchange of this (primary, sensitive) data complies to the design criterion of keeping the data at a source.

The ‘Intermediary Roles’ in the IDS reference architecture act as trusted entities and should only be assumed by trusted organizations. The functions they provide and the data they process are listed in Table 1 for the main intermediary trusted roles.

Intermediary Trusted Roles		
IDS Role	Functions	Type of data processed
Identity Provider	- Maintain / Manage Identities of Participants - Validate Identities of Participants	- Stakeholder Identity Information
Clearing House	- Clearing / Transaction Logging - Settlement / Billing - Conflict Resolution	- Transaction records - Billing records - Stakeholder Identity Information
Broker Service Provider	- Registration / Publication of Data Sources - Exposing / Discovery of Data Sources - Legal Agreements / Terms of Use	- Meta-data - Data Descriptions - Legal / Contract Information - Stakeholder Identity information

Table 1: Description of the main Intermediary Trusted Roles in the IDS reference architecture.

As the table shows the intermediary trusted roles of the Identity Provider, the Clearing House and the Broker Service Provider process data that should be handled as trusted. They may contain and process trusted data that is related and refers to the data provider and data consumer and the data that they exchange, as enumerated in the right column of the table. Hence, these roles require additional attention as they are an integral part of the sharing of data in the supply chain, and as such form an essential link in the overarching trust architecture for the multi-tenant data sharing infrastructure.

The remainder of this paper will consider whether and how emerging block chain technologies may play a role in the architecture and design of the intermediary trusted roles of the IDS multi-tenant, trusted, data sharing reference architecture.

To assess this potential role of the emerging block chain technologies in the implementation design of the IDS multi-tenant, trusted, data sharing reference architecture, it is essential to start with the concept of trust and what block chain technologies may mean for realizing trust. This is described in the following section.

3 Blockchain technology: its potential

Blockchain technology provides a promising option for implementing distributed ledger architectures. As such, it is currently attracting major attention. The essence of block chain technology can be described as (literal citation from (“Blockchain” 2018):

“A blockchain, originally block chain, is a continuously growing list of records, called blocks, which are linked and secured using cryptography. Each block typically contains a cryptographic hash of the previous block, a timestamp and transaction data. By design, a blockchain is inherently resistant to modification of the data. It is “an open, distributed ledger that can record transactions between two parties efficiently and in a verifiable and permanent way”. For use as a distributed ledger, a blockchain is typically managed by a peer-to-peer network collectively adhering to a protocol for inter-node communication and validating new blocks. Once recorded, the data in any given block cannot be altered retroactively without the alteration of all subsequent blocks, which requires collusion of the network majority.

A blockchain based solution can add (significant) value in improving efficiency and stimulating trust in multi-tenant data sharing in the supply chain:

- *Minimization the functionality of trusted roles:* As described in the previous section, the intermediary trusted roles (such as the Identity Provider, the Clearing House and the Broker Service Provider in the IDS reference architecture) process data that should be handled as trusted. Hence, these roles require additional attention as they are an integral part of the sharing of data in the supply chain. Blockchain technology may minimize the functionality of trusted roles by circumventing a centralized and trusted data processing function.
- *Conflict resolution:* A distributed ledger can prevent conflicts and discussion. All parties in the supply chain need similar information- and a shared ledger creates a unambiguously overview of the agreements made and the status of the goods at “moment and location X”. In the traditional process the status of goods – and the exact terms parties agreed upon can cause a lot of discussion – due to the fact that every party is holding its own truth/database, and agreements are unique for each contract;
- *Smart logic:* Processes in the supply chain can be automated based on (simple) smart contract logic. Time, location and condition-based triggers can fire specific rules. When you record that ‘a specific container arrives at a specific location in a specific condition’ payments can be made, or release statuses automatically set. In a similar setting it can be arranged how much a company needs to pay in case a container arrives at a certain location earlier or later than agreed on. If both agreements and status updates are immutable recorded (and legally traceable) in a distributed ledger, the ultimate output – payments, releases, information – can be automated as conditions are filled.

4 Using blockchain for intermediary, trusted, roles in the multi-tenant, data sharing reference architecture

The intermediary trusted roles in the IDS reference architecture as depicted in Figure 1, should take a similar architectural and design approach into account for processing the trusted data (as described in Table 1). In these complex supply chains, not only do the data sharing parties often don’t know each other, they often also lack the knowledge and trust (in the ‘trustworthy’ data processing function) of these intermediary trusted roles. Therefore, preventing centralized storage of this data and thereby creating dependency on (actual trustworthiness of) an intermediary trusted role, may provide an attractive implementation option.

As described in the previous section, emerging blockchain technologies may provide such alternatives for the minimization and implementation of the centralized data storing and processing functions of the intermediary trusted roles (Boston Consulting Group n.d.). The subsequent paragraphs of this section describe how blockchain technology could be positioned for implementing the intermediary trusted roles of the Identity Provider, the Clearing House and the Broker Service Provider, respectively.

It is to be noted that this approach on assessing blockchain technology as implementation alternatives within the role and functional model as illustrated in Figure 1, ensures that these technologies are positioned in compliance with the high-level IDS reference architecture. Alternatively, it could also be considered and assessed whether and how blockchain technologies may lead to alternative architectures in which this (primary, sensitive) data is stored, processed and distributed using a blockchain. In our perception, that would imply a fundamentally different architectural approach, not in compliance with the high-level IDS reference architecture and principles. However, this fundamentally different approach is *not* part of the current paper.

4.1 Identity Provider

Identity provisioning is a research topic for a long time, however recently it gained more attention due to the blockchain developments. (Allen 2018) has written down ten principles for self-sovereign identity and ensuring that user control is the core part.

1. **Existence.** *Users must have an independent existence.*
2. **Control.** *Users must control their identities.*
3. **Access.** *Users must have access to their own data.*
4. **Transparency.** *Systems and algorithms must be transparent*
5. **Persistence.** *Identities must be long-lived.*
6. **Portability.** *Information and services about identity must be transportable*
7. **Interoperability.** *Identities should be as widely usable as possible.*
8. **Consent.** *Users must agree to the use of their identity.*
9. **Minimalization.** *Disclosure of claims must be minimized.*
10. **Protection.** *The rights of users must be protected.*

Within IDS the role of identity provider is described as a central role in the architecture. Hence, we suggest that an identity blockchain such as Sovrin can give more advantages instead of a central role in the architecture.

“As an individual’s or organization’s Sovrin identity builds up over time, so does their reputation. Stepping up from a low trust level to a higher trust level happens seamlessly as more verified attributes and claims are accumulated by the identity owner. This reputation becomes an asset of the identity owner. For example, an individual may choose to reveal their reputation to others to establish and reinforce trust, or an organization may publish its Sovrin-based reputation ratings as a badge of honor.

This also produces a virtuous network effect. Organizations that are trusted by other organizations as providers of verified claims automatically enhance their own reputations. The more individuals and organisations that rely on your claims, the higher your reputation.” (“Inevitable Rise of Self-Sovereign Identity” n.d.)

By using this approach, we foresee a higher acceptant rate in the business field for sharing data. Currently multi-tenant, trusted data sharing infrastructure are hard to maintain and especially the usability is below the norms that are required in the supply chain. In the real world we have an identity document or a driver license where a central authority provides the document, however in the online world this is hard to achieve. In practice you only have a username and password for each site and/or environment.

With Sovrin for example it is possible to create automatic checking of your identity and get access to right information depending on the right you have. And able to share data with other on your own terms.

4.2 Clearing House

The clearing house acts as a trusted, intermediate entity between the Data Provider and the Data Consumer. Its main function is to provide clearing and settlement services for data exchange transactions, including (Boris Otto et al. 2016):

- *Clearing / Transaction Logging*: Both the transmission of data by the Data Provider and the reception of data by the Data Consumer should be confirmed by logging them in a transaction record at the Clearing House.
- *Settlement / Billing*: Billing records can be created based on the transaction record. The transaction can be billed, and the invoices created.
- *Conflict Resolution*: Conflicts can be resolved based on the information that has been logged in the clearing house. This may for instance occur when it needs to be clarified / confirmed that a specific data transaction has occurred and that the data has been received by a Data Consumer.

To implement clearing and settlement services for data exchange transactions by means of blockchain technology, imposes several requirements on the blockchain implementation for ensuring the added trust level:

- The data provider is in control over the insertion of his data transaction logging information on the provisioning of data into the appropriate data transaction ‘clearing’ blockchain, i.e. without an enabling intermediate party. This avoids an additional intermediate party to be trusted.
- Similarly, the data consumer controls the insertion of his data transaction logging information on the reception of data into the appropriate data transaction ‘clearing’ blockchain, i.e. without an enabling intermediate party. This avoids an additional intermediate party to be trusted.
- Confidentiality of transaction records: both with respect to the transaction meta-data (e.g. the identities of the involved parties) and the actual content of the data transaction (type and content of the data that has been shared).

For providing trustworthy clearing and settlement services, it is a prerequisite that trustworthy identities are used when inserting logging data into the appropriate data transaction ‘clearing’ blockchain, for which the services of the Identity Provider (possibly based on a blockchain implementation as described in the previous paragraph) may be used.

A blockchain solution direction for the clearing house functions that circumvents the (potential) trustworthiness issues of a centralized, data storing, trusted clearing house role may have the following features:

- Instances of data transaction ‘clearing’ blockchains being initialized by the data provider for logging specific data sharing sessions;
- The receipt of trusted data sharing transactions is acknowledged by means of secured data receipt records, preferably with (reference to) the legal agreements / terms of use under which these data sharing transaction has been done;
- The secured / certified data receipt records are inserted in the data transaction ‘clearing’ blockchain.

Several implementation strategies can be considered. The data provider may have its own infrastructure for initiating and managing his instances of data transaction ‘clearing’ blockchains. The advantages are higher level of control and low (non) dependency on the (trustworthiness of) third party clearing house role. The disadvantage is the added complexity of managing the blockchain infrastructure. As alternative, a Blockchain Service Provider role may be introduced that provides blockchain management services for initializing and managing instances of data transaction ‘clearing’ blockchains. This unburdens the data provider from the added complexity of managing the blockchain infrastructure. However, this again introduces a central trusted role, although with a limited / lightweight (and possibly untrustworthy) functions it provides as compared to a full Clearing House role. Both variants are depicted in the left-hand side and the right-hand side of Figure 2, respectively.

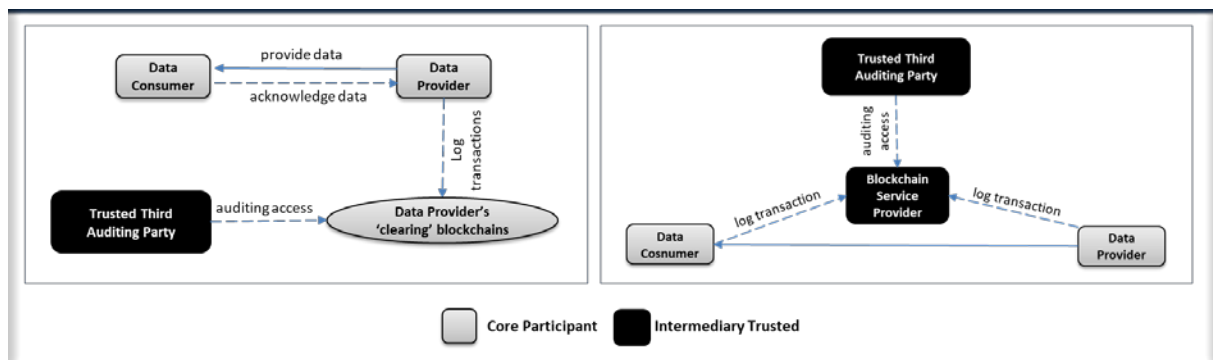

Figure 2: Implementation variants for blockchain technology to support clearing house functions.

4.3 Broker Service Provider

As listed in Table 1, the main functions of the trusted Broker Service Provider role is to enable a registry for the publication and discovery of available Data Sources, together with the applicable legal information and terms of use. As such, a Broker Service Provider handles metadata on the available data sources and contract information. With the combination of metadata on available data sources and contract information, various inter-organizational governance arrangements can be supported (market, bazaar, hierarchy, network) (van den Broek and van Veenstra 2017).

The metadata and contract information to be handled by the Broker Service Provider is in principle public data and is freely available for all interested parties to search for and be discovered. As such, the added value of blockchain features for implementing the data registry of the Broker Service Providers include:

- Integrity can be ensured of the combined and linked information on the available data sources, the legal agreements / terms of use and contractual / pricing conditions under which the data will be provided by the Data Provider.
- The combined and linked information is transparent, traceable and auditable, thereby providing the possibility for conflict resolution in case of differing perceptions between stakeholders on the data description, the legal agreements / terms of use and contractual / pricing conditions and legal under which the data source has been advertised.

- The Data Registry system is resilient, without a single point of failure or corruption,

In case a specific Data Provider decides to selectively publish and make available the metadata for his data only to specific communities or parties, various implementation variant may be considered. The data provider may have its own infrastructure for initiating and managing his instances of data transaction ‘clearing’ blockchains. The advantages is higher level of control and low (non) dependency on the (trustworthiness of) third party clearing house role. The disadvantage is the added complexity of managing the blockchain infrastructure. As alternative, a Blockchain Service Provider role may be introduced that provides blockchain management services for initializing and managing instances of data transaction ‘clearing’ blockchains. This unburdens the data provider from the added complexity of managing the blockchain infrastructure. However, this again introduces a central trusted role, although with a limited / lightweight (and possibly untrustworthy) functions it provides as compared to a full Clearing House role. Both variants are depicted in the left-hand side and the right-hand side of Figure 2, respectively.

5 Conclusions, Discussion

In this paper we have considered the potential role of blockchain technology for realizing added trust levels in a trusted multi-tenant data sharing infrastructure by providing de-centralized data storage functionality for the implementing roles of the Identity Provider, the Clearing House and the Broker Service Provide roles.

On the basis of the results as presented in this paper, the next step is to further elaborate this high level blockchain architectural approach in a detailed infrastructure design, in which the embedding of blockchain technologies within the IDS trusted, multi-tenant data sharing reference architecture is further detailed. This will be done in close cooperation with the blockchain community with the IDS research and development initiative.

5.1 Future work

We foresee that more work is required in the sense of validation of the IDS architecture in combination with our claim that blockchain technology can beneficial as an intermediary, trusted, roles in the multi-tenant, data sharing reference architecture. Instead having a central roles and actors this can help to build trust amongst partners and not having a single point of failure. Furthermore, we aim to setup a business experiment in validating our suggestion to improve IDS.

Currently there aren’t successful implementations of a heterogenous trusted data sharing infrastructure due to all kind off reasons (trust, IT, cost, competition), however with the speed of the adoption of the blockchain we foresee some progress on some of these factors. And this will also increase the knowledge regarding these complex subjects in the practitioner field. Which is very important.

Acknowledgement

The work as presented in this paper has been done as part of the Dutch NOW Research project ‘Data Logistics for Logistics Data’ (DL4LD), supported by Dutch Institute for Advanced Logistics ‘TKI Dinalog’ (www.dinalog.nl) and the Dutch Commit-to-Data initiative (www.dutchdigitaldelta.nl/big-data/over-commit2data).

References

- Allen, Christopher. 2018. *Self-Sovereign-Identity: Articles and Documents Associated with Designing and Implementing Identity Technology Using Self-Sovereign Identity Principles*. <https://github.com/ChristopherA/self-sovereign-identity>.
- Boris Otto, Jan Jürjens, Jochen Schon, Sören Auer, Nadja Menz, Sven Wenzel, and Jan Cirullies. 2016. "INDUSTRIAL DATA SPACE DIGITAL SOVEREIGNTY OVER DATA."
- Boston Consulting Group. n.d. "Does Your Supply Chain Need a Blockchain?" Accessed May 8, 2018. <https://www.bcg.com/publications/2018/does-your-supply-chain-need-blockchain.aspx>.
- Broek, Tijs van den, and Anne Fleur van Veenstra. 2017. "Governance of Big Data Collaborations: How to Balance Regulatory Compliance and Disruptive Innovation." *Technological Forecasting and Social Change*.
- Crujssen, F. C.A.M. 2006. "Horizontal Cooperation in Transport and Logistics." *Open Access Publications from Tilburg University*.
- Dalmolen, S, Moonen, H M, and Cornelisse, E. 2012. "Information Architecture Using a Cargo Centric Approach – Digital Shadows of Real World Objects." In .
- Dalmolen, S., H. M. Moonen, J. van Hillegersberg, A. J. R. Stoter, and E. Cornelisse. 2015. "Supply Chain Orchestration and Choreography: Programmable Logistics Using Semantics." In *Advanced Logistics and Transport (ICALT), 2015 4th International Conference on*, 76–81. IEEE. http://ieeexplore.ieee.org/xpls/abs_all.jsp?arnumber=7136596.
- European Commission, EU Agenda. n.d. "A Truly Integrated Transport System for Sustainable and Efficient Logistics." EU Agenda. Accessed May 7, 2018. <https://euagenda.eu/publications/a-truly-integrated-transport-system-for-sustainable-and-efficient-logistics>.
- "Inevitable Rise of Self-Sovereign Identity." n.d. *Sovrin* (blog). Accessed May 8, 2018. https://sovrin.org/library_items/rise-of-self-sovereign-identity/.
- Luftman, Jerry, Kalle Lyytinen, and Tal ben Zvi. 2017. "Enhancing the Measurement of Information Technology (IT) Business Alignment and Its Influence on Company Performance." *Journal of Information Technology* 32 (1): 26–46.
- Trusted Computing Group. 2013. "Trusted Multi-Tenant Infrastructure Work Group - Reference Framework."



IPIC 2018

Copyright © 2018 University of Groningen
www.pi.events
ipic2018@rug.nl