

# Does Corporate Social Responsibility Lead to Improve in Firm Financial Performance? Evidence from Malaysia

Wan Suhazeli Wan Ahamed<sup>1</sup>, Mahmoud Khalid Almsafir<sup>1</sup> & Arkan Walid Al-Smadi<sup>1</sup>

<sup>1</sup> Graduate Business School, College of Graduate Studies, Tenaga National University, Malaysia

Correspondence: Arkan Walid Al-Smadi, Graduate Business School, College of Graduate Studies, Tenaga National University, Putrajaya Campus, Jalan IKRAM-UNITEN, 43000 Kajang, Selangor, Malaysia. E-mail: arkan.alsmadi@yahoo.com

Received: November 28, 2013

Accepted: December 9, 2013

Online Published: February 25, 2014

doi:10.5539/ijef.v6n3p126

URL: <http://dx.doi.org/10.5539/ijef.v6n3p126>

## Abstract

Corporate Social Responsibility (CSR) as a common business practices has only recently established a foothold in developing countries. This paper examines the relationship between CSR and Corporate Financial Performance (CFP) for a Malaysia firms. Malaysia was chosen due to it's one of worlds developing countries and has undergone radical economic and social change. The objective of this research to determine whether CSR based on environment, community, marketplace and workplace dimension has positive, negative or neutral relationship with CFP. The empirical study used to collect secondary data from corporate annual report for three firms listed in Bursa Malaysia for the period from 2007 to 2011. The data taken and gather by using content analysis. CSR dimension of workplace, community, environment and marketplace is used as independent variable while Return on Asset (ROA) and Return on Equity (ROE) is used as dependent variable. Regression analysis used to test the relationship by using SPSS. Prior studies had produce mixed result but most research found there is positive relationship between CSR and CFP. The result of this study concludes that there is positive relationship between CFP and CSR practices together with Firm Size and Firm Revenue as control variable. As well as, this paper will contribute to finance and accounting literature in identified investment in CSR will lead to firm financial performance or otherwise.

**Keywords:** Corporate Social Responsibility (CSR), Corporate Financial Performance (CFP), Coporate Social Responsibility Disclosure (CSRD), Return on Asset (ROA), Return on Equity (ROE)

## 1. Introduction

### 1.1 Background of Study

Over the last decades, Corporate Social Responsibility (CSR) has become dominant topic in corporate world nowadays. Wheelen and Hunger (2012) suggest that corporation has responsibilities to society that extend making profit. CSR can be broadly defined as the activities making companies good citizens who contribute to society's welfare beyond their own self-interests (Khanifar, Nazari, Emami, & Soltani, 2012). Caroll (1979) outlined that the business firm has four responsibility, which its must obliged to their stakeholder and must be satisfy in order of priority—being economic responsibilities by making profit to the shareholder, being legal responsibilities by complying to law and regulation govern by authority, being ethical responsibilities by doing the right thing beyond law requirement and being discretionary responsibilities by performing actions or activities on voluntarily basis.

Ghelli (2013) eximend the increasing level of industrialization has cause a saturated even a depletion of natural resources, which affects on the future equilibrium of the world and the best way to prevent this destructive behaviour, is by adopting and nurturing social responsible practice. In the last decades, the theme of CSR has been gathering momentum and many firms started reporting about their ethical, social and environmental conduct due to increasing pressure from shareholders, employees, organization and all the stakeholders in general.

CSR have practice in the most developing countries and become known by most large corporation in Malaysia gradually. Based on research conducted on Malaysia companies, 97.5% of the 198 respondents agreed that Malaysian companies are involved in CSR activities (Lo & Yap, 2011). Philosophy of top management and

legislation were the primary factors Malaysia firms contributing to CSR rather taking it to achieving long-term profitability and firm sustainability. Ramasamy, Ting and Yeung (2007) pointed out Malaysia firm's attitude towards CSR disclosure generally low, however the awareness increase gradually due to emergences of Non-Governmental Organization (NGO) and consumer interest group. The importance of CSR has triggered government intervention, as Malaysia Prime Minister, Dato' Seri Najib Tun Razak mentioned in the 2006 budget speech, all Public Listed Companies are required to disclose their CSR activities.

One important aspect need to be taking into consideration by corporation is that being socially or environmentally responsible will definitely add costs to the organization which in turn reduce the level of company profitability (Iqbal, Ahmad, Basheer, & Nadeem, 2012; Khanifar et al., 2012). Nevertheless, corporation still embrace in CSR as it contribute benefit to corporate public relations, media campaigns and reputation management (Boesso, Kumar, & Michelon, 2013). Furthermore, being socially responsible may direct corporation to better resource, increase employee motivation, lead to effective marketing; this entire factor will result creation of unforeseen opportunities within the industry (Iqbal et al., 2012).

Study on relationship between CSR and firm financial performance has received huge interest among the researcher. This due to CSR action ought to correlate with the financial state and outcomes of firms (Karagiorgos, 2010).

### *1.2 Problem Statement*

Engagement in CSR has become common practice by large corporation in develops country but it is a still debatable issue in emerging countries. No doubt, involvement in CSR required substantial amount of money and resourced to allocate which will result lower corporation profitable margin. Furthermore, in current competitive business market, resources need to intelligently allocate and fully utilized for generating corporation income rather than being socially responsible. Most firm in emerging countries contributing to CSR due to legislation requirement and to enhanced corporate reputation. It seems uncertainty whether involvement in CSR will affected firm financial performance positively or negatively. There is less of literature available on this issue especially on emerging country; perhaps one of the factors firm cautiously in performing CSR.

Another issue emerge is the study on the relationship between CSR and CFP itself. The empirical analysis of the relationship between CSR and CFP has yet to provide a convincing causal link between two variables (Mwangi & Jerotich, 2013). Study on this relationship had produce mixed result whether it is positive, negative or neutral relationship between CSR and CFP. Raza, Ilyas, Rauf and Qamar (2012) had perform literature analyse on relationship between CSR and CFP that using content analysis from 1972 to 2012. From 76 numbers of studies, 48 studies found positive relation, 4 studies found mixed relation, 8 studies found negative relation and 16 studies found there is no relation between CSR and CFP.

Problem surface in Malaysia corporate entity was the lack of transparency and commitment towards CSR. Even though there is CSR practise adopted by some corporate entity, the volume and the amount of CSR participation towards community well-being is questionable. Due to this issue, Malaysia Prime Minister, Dato' Seri Najib Tun Razak during his 2006 budget speech has direct all Public Listed Companies must disclose their CSR activities in their annual report or produce another sustainability report emphasis on CSR (Ting & Yeung, 2007).

### *1.3 Research Objective*

Based on the problem outline, due to the uncertain relation and lack of information on the relation between CSR and company financial performance, the primary objective of this research paper is to study the relation between CSR and CFP of public listed company in Malaysia.

### *1.4 Research Question*

In order to arrive or archive on our research objective and to find whether there is relationship between CSR and Corporate Financial Performance (CFP) the question need to derived.

- i) Is there any relationship between CSR disclosure and firm ROA?
- ii) Is there any relationship between CSR disclosure and firm ROE?

### *1.5 Significance of Study*

The result of the study can be contribute significantly whether adopting CSR will affect firm financial performance. Following the directive from Bursa Malaysia instructed starting from 2007 onward firm listed in Bursa Malaysia compulsorily need to disclose CSR activity conduct by the firm in their annual report or produce a sustainability report; this research will determine whether this instruction has direct impact on firm financial performance.

## 2. Literature Review

According to Mishra and Suar (2010), The history of CSR was stretches back to the late 50's and 60's which in United States, it was a period of new legislation regarding equal opportunities, consumer rights, occupational safety and environmental protection in which organisations responsible to the society. Today, there is an increased pressure on organisations to act ethically and socially responsible and there is increased pressure on many organizations to acknowledge their responsibility to society (Sun, 2012). Behaving in a socially responsible manner increasingly seen as essential to the long-term survival of companies.

CSR concept emphasizes and proposes that a firm has responsibilities to society that extend beyond making a profit (Mwangi & Jerotich, 2013). This concept outline it is the obligation of the firm's decision makers to make decisions and act in ways that recognize the relationship between business and society, therefore it's important for business to continue its commitment to behave ethically and contribute to economic development while improving the quality of life of the workforce and the surrounding community (Sun, 2012). Wood (1991) describes CSR consist of three major components which first component is the level of corporate social responsibility which is based on legitimacy within society, public responsibility within the organization and managerial discretion by each individual within the organization. This follow by the second elements, which are, consist the process of corporate social responsiveness, which includes environmental assessment, stakeholder management, and issue management and third elements refer to the outcome of corporate behaviour, which includes social impact, social program and social policy.

The way researcher measuring CSR has become most debacle issue. This due to CSR value is critical and important factor in determines the outcome of the research and the validity of the relationship. Varies outcome from the analysis is mostly dependence on the CSR value. Dkhili and Ansi (2012) have outlined five different method of measuring CSR:

- i) Performing content analysis by measure of speech, such as content analysis of annual reports, which are to based on remarks made by companies to assess their CSR activities. Example of this content analysis is by counting number of lines or words dedicated to themes CSR in the annual report of the company (Aras, Aybars, & Kutlu, 2009; Mwangi & Jerotich, 2013; Ngwakwe, 2009; Ramasamy, Ting, & Yeung, 2007; Saleh, Zulkifli, & Muhamad, 2011; Uadiale & Fagbemi, 2012; Karagiorgos, 2010).
- ii) Indicator of pollution provided by some agencies to assess the pollution of businesses such as the Toxic Release Inventories in the U.S. For example, measurements of the diffusion of CO<sub>2</sub> by businesses (Uwugbe & Egbide, 2012).
- iii) Measures of attitudes and values aimed at assessing the sensitivity of members of the organization. Example of this measurement is via questionnaires (Bayoud, Kavanagh, & Slaughter, 2012; Mishra & Suar, 2010).
- iv) Measures of reputation such as the indicator of reputation developed by Markowitz in the 1970s in the American Magazine Fortune which includes criteria related to CSR that are assessed by a panel of industry experts to which operates within the enterprise in question.
- v) The behavioural measure or audit developed by the agencies that specialize in the assessment of social behaviour and environmental responsibility such as the U.S. KLD (Boesso, Kumar, & Michelon, 2013; Lioui & Sharma, 2012; Nelling & Webb, 2008; Sun, 2012) EIRIS in Britain or in France Vigeo.

However, there is another method not outlined Dkhili and Ansi (2012) on measurement of CSR, that is the amount of donation or charity contribute by the company (Ehsan & Kaleem, 2012). Within the measurement of the CSR itself, Karagiorgos (2010) has indicate that it is important for the measurement to have a 'multiple-indicator, multiple-causes' (MIMIC) due to CSR involve multiple obligation. For example, measurement of CSR cannot be measure by contribution to community only but must also include contribution of the firm to community, environment, employees and other social obligation in aggregate.

Measuring financial performance was most critical part in this research. The classical view of financial performance is maximizing the wealth of agents who are shareholders (Dkhili & Ansi, 2012). Based on markets efficiency that ensures the best allocation of resources and rejects any idea of corporate responsibility other than making profit for its shareholders. Most of the financial measures are obtain from company financial statement inside company annual report. Most researchers typically used accounting-based measures (Aras, Aybars, & Kutlu, 2010; Saleh, Zulkifli, & Muhamad, 2011; Sun, 2012; Bayoud, Kavanagh, & Slaughter, 2012; Iqbal et al., 2012) and market or stock based measure (Boesso, Kumar, & Michelon, 2013) as CFP measurement. The accounting measures provide most positive correlation result from analysis on relation between CSR and CFP (Dkhili & Ansi, 2012). This due to accounting measure has the advantages of providing more relevant economic

performance of the company and provides more reliable data on linkage between CSR and CFP. However, accounting based measures are “susceptible to differential accounting procedures and managerial manipulation” (Karagiorgos, 2010).

Return on Assets (ROA) and Return on Equity (ROE), two most popular measurement used by researcher, are accounting ratios which shows that how effectively and efficiently management use corporate’s asset and equity to enhance inventory turnover and sales to earn profit (Raza et al., 2012).

Nelling and Webb (2008) explored and found that the relationship between CSR and CFP as “virtuous circle” since it determine “doing socially good” will contribute to healthy financial performance or whether firm exhibit superior financial performance will devotes more resource for social obligation. In addition, using OLS regression with ROA and return on firm’s common stock as dependent variable, weighted CSR score as independent variable, and vice versa; generate similar positive result.

Study on relationship between CSR and CFP has produce vast number of literature and produce mixed results. Aras, Aybars and Kutlu (2010) investigated the relationship between CSR and CFP by performed regression analysis with profitability as dependant variable and CSR and firm size as independent variable, found there is no significant relationship between CSR and company profitability. However, there is significant relationship between firm size and CSR. By adding R&D intensity as independent variable still produces negative relationship. This contradicts with Lioui and Sharma (2012) which performing analysis on direct and indirect relation; reveal negative interaction between CSR and CFP but produce positive relation when R&D added as independent variable. This study support McWilliams and Siegel (2000) statement, specified that some studies of the relation between CSR and CFP suffer from several important theoretical and empirical limitations due to omitted R&D intensity in the variable.

The theory of stakeholder could explain the relationship between CSR and CFP (Barnett, 2007). According to the stakeholder theory, the value of the company related to the cost of both “explicit claims” and “implicit claims” on a company resource. Stakeholders have an explicit claim on a company including owner-lenders, employees and the government. There are numerous claims on the management of the company from the external stakeholders, which referred to as implicit claims. Cornell and Shapiro (1987) state that some implicit claims consist of the continuity of supplies, on-time delivery, the increase in the quality of products, work safety as well as involvement in social and environmental activities. The price that must paid by stakeholders for this claim depends on the company’s situation including the financial policy applicable to the company.

Over the world there are some research found a mixed result in the relation between CSR and organizational performance such as research conducted by (Bayoud, Kavanagh, & Slaughter, 2012) eximend the relationship between CSR and CFP by using questionnaire to 135 organizations. The result found a positive relationship between Corporate Social Responsibility Disclosure (CSRD) and CFP, while the corporate reputation was negative relationship between CSRD with employee commitment. Moreover, Boesso, Kumar and Michelin (2013) using three different approaches—instrumental, descriptive and strategic found positive relationship between CSR and CFP for instrumental and strategic approach and negative relationship for descriptive approach.

Timeframe play an important role when investigate the link between CSR and CFP. Even though firms engage actively in CSR, due to bad economic period, it may result negative relationship. Thus, Saleh, Zulkifli and Muhamad (2011) using data on 474 companies listed in the main board of Bursa Malaysia collected starting from 1999 to 2005 instead of year before. This timeframe perceive as the recovery period after most Asian country hit by financial crisis.

Most previous studies consider companies across industries (Balabanis, Philips, & Lyall, 1998; Cochran & Wood, 1984). Griffin and Mahon (1997) criticize a multi-industry analysis, pointing to the fact that different levels of CSR and CFP based on its particular internal and external pressures. Taking example of oil and Gas Company, the company may disclose and emphasize more on the environment dimension of CSR and probably beyond required by the law and the level of their financial performance due to absurd pressure from others such as Greenpeace that capable to make sensational stories for the media.

While Aras, Aybars and Kutlu (2010) using number of sentences disclose in the annual report and Saleh, Zulkifli and Muhamad (2011) using indexing the CSR disclosure to measure the CSR, Sun (2012); Boesso, Kumar and Michelin (2013); Nelling and Webb (2008) using KLD index as measurement for CSR. KLD provides rating data in seven qualitative areas namely community, corporate governance, diversity, employee relations, environment, human rights and product. Iqbal et al. (2012) measure CSR by developing and computing index based on corporate governance, business ethical principle, environmental compliance, social compliance,

disclosure environmental and social report, product integrity, corporate giving's and community investment, stakeholders dialogue and supply chain security.

Research in the developing countries when generally observed, the extent of corporate environmental disclosures in annual report is lower than in the developed countries (Uwuigbe & Egbide, 2012). Savage (1994) examined the CSR practices of 115 companies in South Africa, found that as many as 50% of the firms had shown CSR with human capital disclosure become priority followed by disclosure on community involvement and environmental performance.

Emerging country has become popular subject to investigate the relationship between CSR and CFP. For example, Aras, Aybars and Kutlu (2010) conduct a research using sample for 40 companies listed in Istanbul Stock Exchange (ISE) from 2005 to 2007 and Saleh, Zulkifli and Muhamad (2011) performed investigation using sample of 200 largest companies listed in Bursa Malaysia Main Board by utilize 1999 to 2005 timeframe. Turkey and Malaysia considered as emerging economic countries.

Malaysian Public Listed Companies (PLC's) have to consider and implement CSR activities in their business operations for awareness and public demands on good CSR initiatives (Saleh, Zulkifli, & Muhamad, 2011). It also supports the government aspiration to attract the foreign direct investment to invest in the capital market by promoting good CSR practices among the PLC's in Malaysia. Thus, involvement in CSR practices may used as a strategy to attract investors and improve firm financial performance of companies and therefore the decision on the expenditure relating to CSR activities should be evaluated and analysed as other investment decisions undertaken by companies (McWilliams & Siegel, 2000).

Azlan and Susela (2008) assert that the pressure of the government is a dominant factor motivating for the involvement of the Malaysia companies into CSR. As the market is getting highly competitive, firms should take initiative and action to improve their involvement in CSR activities as part of their business strategy to maintain firm sustainability. Furthermore, the involvement in CSR would add advantage to the companies if they were planning to go global in which consumer in global market usually concerned with CSR issues. In addition, the owners of capital in global markets, particularly socially responsible investor are looking forward at CSR as their key criteria in their investment decision. Thus, the involvement of the Malaysia firms in CSR is a preliminaries and entry requirement on the global market and as a strategy to attract funding form institutional investors. Additionally, the education level of the local consumers has also improved thus playing more active role in ensuring high commitment from the companies (Haniffa & Cooke, 2005).

In Malaysia, a few major empirical studies have published on CSR practices. These include a personal interview questionnaire survey conducted by Teoh and Thong (1984) which surveyed a combination of one hundred foreign and locally owned companies in Malaysia. The study focused on three issues; namely, the concept of CSR, the nature and extent of corporate involvement in such activities and corporate social reporting. The results found that only 29% of the companies in the sample reported on CSR in their annual report. The rest, constituting of 71% did not reveal their CSR activities. The study also revealed that foreign-owned companies made more CSR disclosures than local Malaysian companies did. The areas of reported most frequently were human resources and products or services to companies. The study however, did not examine the extent of CSR. The major limitation of this study based solely on personal interviews with no attempt to examine other major means like content analysis approach. Meanwhile, Andrew, Gul, Guthrie and Teoh (1989) examined 119 annual reports of publicly listed companies in Malaysia and Singapore in 1983; found that only 26% of the companies had CSR. They also found there was a high number of large and medium size companies disclosed social information as compared to smaller sized companies. Human resources disclosure was also the dominant theme. The industry that had the highest proportion of companies with CSR in their annual reports is the banking and finance industry. On the whole, the study clearly showed that the level of CSR, then, was very low, ranging from less than a quarter of a page to slightly more than one page. The authors, however, did not make any distinction between Malaysian and Singaporean companies. As a result, it is not practical to get a clear distinctive of the CSR in each of these countries.

### **3. Research Methodology**

The data and the sample size used in this paper and the measurement of CSR as well as CFP are will described in this section.

#### *3.1 Sample and Data Size*

The main purpose of this paper is to find out whether there is significant relationship between CSR and CFP among company in Malaysia. To achieve this objective, the study had adopted the use of corporate annual

reports of listed firms as our main source data of data. This due to the fact that annual reports for selected corporate are readily available and accessible. As well as, the Data and sample size taken from three large companies listed in main board of Bursa Malaysia for a period from 2007 to 2011. This period chosen based on these two criteria:

- i) This time span is selected due to it is the recovery period from financial crisis that hit Asian countries and particularly the Malaysia capital market. It is perceived that when the financial crisis is over, most companies could then allocate their spending on CSR activities (Saleh, Zulkifli, & Muhamad, 2011).
- ii) Malaysia Prime Minister, Dato' Seri Najib Tun Razak during his 2006 budget speech, has highlight starting 2007, all Public Listed Companies required to disclose all their CSR activities in their financial report. Even though some of the company has done it, most of the report is voluntarily action and not according to framework stipulated by Bursa Malaysia. The CSR framework set by Bursa Malaysia must according to environment, workplace, community and marketplace dimension. (Ting & Yeung, 2007).

The Data collected from company's annual report, Bursa Malaysia web site and Central Bank of Malaysia. This assessable source available in hardcopy and electronic format.

### *3.2 Measurement of CSR*

It is common that CSR practices represented by CSRD, which can be obtained from corporate annual reports. Note that the measurement of amount spends or donation on CSR will be more accurately the link to the firm financial performance, however, it is hard and difficult to get the exact amount spend for corporation investing in CSR. This accordance to Bursa Malaysia CSR disclosure framework, a Malaysia corporation need to disclose their CSR activities on environment, workplace, community and marketplace with no obligation to disclose the exact amount. Research by Ehsan and Kaleem (2012) capable to make the donation amount as CSR measurement is due to in compliance with part III, E-1 of schedule 4, Securities and Exchange Commission of Pakistan (SECP), it is compulsory for all listed companies to inform their spending on corporate donations in the profit & loss accounts. Hence, the measurement of CSR for this paper will base on content analysis method. Content analysis is a method widely used in the studies about disclosure (Aras, Aybars, & Kutlu, 2010; Uadiale & Fagbemi, 2012; Saleh, Zulkifli, & Muhamad, 2011; Ramasamy, Ting, & Yeung, 2007; Uwuigbe & Egbide, 2012; Karagiorgos, 2010).

Moreover, the Prior studies has used different dimension of CSR disclosure. For example, Ngwakwe (2009) used CSRD on Employee Health and Safety (EHS), Waste Management (WM) and Community Development (CD) meanwhile Mishra and Suar (2010) used CSRD on employee, customer, supplier, community and environment dimension. This paper will used environment, workplace, community and marketplace dimension in accordance Bursa Malaysia framework.

The propose process is by using number of sentences used in the annual report. Each annual report will be divided into four section based on environment, workplace, community and marketplace and number of sentences used for each dimension will be tabulated. For CSRD that is not within the dimension, it will be put into the dimension, which is perceived related. For example, CSR on education such as scholarship and sponsorship will rated under community dimension.

### *3.3 Measurement of Financial Performance*

It is expected a certain diversity will occurs on measurement of CSRD, there is also no real consensus on how to proper measure CFP (Uwuigbe & Egbide, 2011). However, most measures of CFP divided into two broad categories; accounting based measure (Bayoud, Kavanagh, & Slaughter, 2012; Iqbal et al., 2012; McWilliams & Siegel, 2000; Mishra & Suar, 2010; Mwangi & Jerotich, 2013) and market based measure (Lioui & Sharma, 2012). Some researcher adopts both of this measure (Ehsan & Kaleem, 2012). Nevertheless, following the precedent of the previous studies, the used of accounting based measure has been received vast attention and mostly used by researcher. Therefore, for the purpose of this paper, CFP will measure by ROA and Return on Equity ROE. The choice preference for this method arises because it has enjoyed periods of popularity and has evolved considerably over the course of the past decade.

### *3.4 Theoretical Framework and Data Analysis Technique*

This research will be develop on two model of theoretical framework, first model the will be analysis on relationship between CSR and CFP without using control variable meanwhile second model will utilize control variable in term of firm size (number of employee within the firm) and firm sales (total revenue for the firm). Regression analysis will used to test the relationship between CSR and CFP. CSRD that consists of environment dimension, community dimension, workplace dimension and marketplace dimension was the independent

variable while firm financial performance represent by ROA and ROE as dependent variable. The Statistical Package for Social Sciences (SPSS) will used to analyse the data collected.

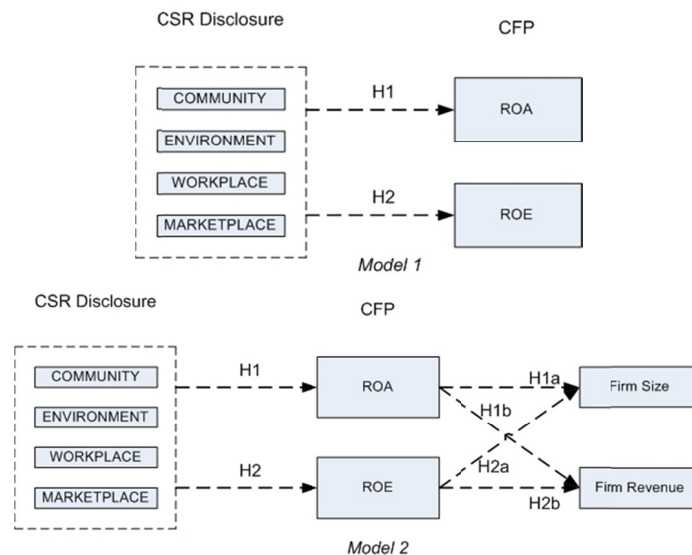

### 3.5 Hypothesis Development

Based on the theoretical framework, to analyse the relationship between CSR (aggregate of community, environment, workplace and marketplace dimension) and CFP (ROA and ROE), following hypothesis is developed:

Hypothesis of model 1:

H1 = there is significant relationship between CSR and ROA;

H2=there is significant relationship between CSR and ROE.

Analysis on relation between CSR and CFP alone cannot used to justify the findings. Prior research include control variable in their study to justify the findings. By adding control variable in the relation may produce similar result, mixed result or different result. For example, research by Aras, Aybars and Kutlu (2010) found there is no significant relationship between CSR with company profitability and still producing no significant relationship when R&D intensity was insert as control variable, however Lioui and Sharma (2012) reveal negative interaction between CSR and CFP but produce positive relation when R&D added as control variable. Thus, to justify findings on H1 and H2, a further investigation was performe by adding control variable in the study and producing following hypothesis:

Hypothesis of model 2:

H1a = there is significant relationship between CSR and ROA with Firm Size;

H1b = there is significant relationship between CSR and ROA with Firm Revenue;

H2a = there is significant relationship between CSR and ROE with Firm Size;

H2b = there is significant relationship between CSR and ROE with Firm Revenue.

## 4. Result Analysis

This section of the paper is devoted to presenting the results of the analysis performed on the collected data to test the hypothesis and find out whether there is any relationship between CSR and CFP. First, we will investigate the correlation between all variable.

Table 1 show the correlation matrix between all variables. Note that the correlation between ROA and ROE are not significant since both variables represent CFP that is dependent variable used in the study. From the table we can see there is significant and positive relationship between ROA and CSR performance (0.804) at  $p < 0.05$  two-tailed. This shows that CSR performance has strong effect on firm ROA. Note that there is also very strong significant and positive relationship between ROA and firm Size (0.868) at  $p < 0.01$  two tailed. This indicate the

more employee employed by the firm, it will contribute to higher firm financial performance (ROA). There is no significant relationship between firm ROA and firm Sales.

Although there is no significant in this study, result also show that there is strong relationship between CSR and firm Size (0.939) at  $p < 0.01$  two tailed and significant relationship between firm Size and firm Sales (0.784) at  $p < 0.05$  two tailed. Positive and significant relation between firm Size and firm Sales justified that higher number of employees will result increase number of firm revenue which in turn improve the level of the firm financial performance (ROA). On the ROE, from the table there is very strong and positive relationship between ROE and CSR performance (0.878) at  $p < 0.01$  two tailed. This indicate the CSR activities within the company is highly related and contribute to the firm ROE. Furthermore, there is strong and positive relationship between firm ROE with firm Size (0.798) and firm revenue (0.708) at  $p < 0.05$  two tailed. This result support same finding the relationship between firm Sizes and ROA. Other significance figure form this analysis there are very strong and positive relationship between CSR and firm Size (0.939) at  $p < 0.01$  two tailed and strong and positive relationship between firm Size with firm Sales (0.784) at  $p < 0.05$  two tailed.

Table 1. Correlation matrix between all variables

		Return on asset	Return of equity	CSR disclosure	No of employee	Firm revenue
Return on asset	Pearson Correlation	1	.636	.804*	.868**	.502
	Sig. (2-tailed)		.090	.016	.005	.205
	N	8	8	8	8	8
Return of equity	Pearson Correlation	.636	1	.878**	.798*	.708*
	Sig. (2-tailed)	.090		.004	.018	.049
	N	8	8	8	8	8
CSR disclosure	Pearson Correlation	.804*	.878**	1	.939**	.640
	Sig. (2-tailed)	.016	.004		.001	.087
	N	8	8	8	8	8
No of employee	Pearson Correlation	.868**	.798*	.939**	1	.784*
	Sig. (2-tailed)	.005	.018	.001		.021
	N	8	8	8	8	8
Firm revenue	Pearson Correlation	.502	.708*	.640	.784*	1
	Sig. (2-tailed)	.205	.049	.087	.021	
	N	8	8	8	8	8

\*. Correlation is significant at the 0.05 level (2-tailed).

To test the multivariate relationship between firm ROA and CSR, we also conducted regression analysis. First analysis was conduct on model (1) to test the hypothesis. Table 2 shows the regression result for ROA and ROE as dependent variable and CSR as independent variable.

From the result, it shows that CSR has direct relationship with both ROA and ROE for this model. This result indicate, for ROA, every unit increase in CSR, firm ROA will increase by 0.14 units, meanwhile for ROE, every unit increase in CSR, firm ROE will increase by 0.19 units. This result support the correlation test indicates there is strong and positive relationship between CSR with ROA and ROA.

Table 2. Regression result ROA/ROE as a constant for model 1

		Unstandardized Coefficients		Standardized Coefficients	t	Sig.
		B	Std. Error	Beta		
a.	(Constant)	.079	1.286		.061	.953
	CSR disclosure	.014	.004	.804	3.315	.016
b.	(Constant)	12.852	1.273		10.095	.000
	CSR disclosure	.019	.004	.878	4.491	.004

Note: a. Dependent Variable: Return on asset; b. Dependent Variable: Return on equity.



The study further used correlation coefficient (R) to check on the magnitude and the direction of the relationship between the independent and dependent variable. Coefficient of determination (the percentage variation in the dependent variable being explained by the changes in the independent variables) and P-Value were used to check on the overall significance of the model; which a predictor variable is said to be significantly related with the response variable if its P-Value < 0.05 (5% significance level). For ROA, Correlation coefficient of 0.804 indicates a strong positive correlation between the dependent and independent variables. On the other hand, coefficient of determination (R) of 0.804 shows that 80.4% of the variation in the firm performance (ROA) explained by the changes in CSR, leaving only 19.6% unexplained.

The regression model obtained for this study can therefore used to forecast firm ROA fairly. The adjusted R square of 59% also shows that the model is a fair estimate of the relationship between the variables. The P-Value 0.016 is less than 0.05, which shows that there is a significant relationship between the dependent and independent variables used in the study thus accept the H1 hypothesis. Proceeding analysis for ROE, the value 0.878 indicate a strong positive relationship between the ROE as dependent variable with CSR as independent variables. 87.8% indicates only 12.2% unexplained. The P-Value of 0.004 shows there is a significant relationship between ROE and CSR in this model thus accept our H2 hypothesis. Summary of the result can obtain from Table 3.

Table 3. Model summary for model 1

	R	R Square	Adjusted R Square	Std. Error of the Estimate	Change Statistics				
					R Square Change	F Change	df1	df2	Sig. F Change
ROA	.804 <sup>a</sup>	.647	.588	.58774	.647	10.989	1	6	.016
ROE	.878 <sup>a</sup>	.771	.733	.58160	.771	20.170	1	6	.004

Note: a. Predictors: (Constant), CSR disclosure.

Further investigation was conduct to justify our H1 and H2 hypothesis by performing analysis to test H1a, H1b, H2a and H2b. Table 4 show the regression analysis result for ROA as dependent variable, CSR as independent variable with Firm Size and Firm Revenue acting as control variable separately.

The result show CSR has inversed relationship with ROA when Firm Size use as control variable and direct relationship when Firm Revenue use as control variable. In other words, decreasing level of CSR by 0.002 units and increasing level of Firm Size by 0.001 units will result increasing level of ROA of the firm by one unit. Meanwhile by increasing level of CSR by 0.14 units and decreasing the level of Firm Revenue by 6.95 units resulting increase level of ROA of the firm by one unit.

Table 4. Regression result ROA as a constant for model 2

	Unstandardized Coefficients		Standardized Coefficients	t	Sig.
	B	Std. Error	Beta		
(Constant)	-15.151	10.346		-1.464	.203
CSR disclosure	-.002	.011	-.091	-.141	.894
No of employee	.001	.001	.953	1.482	.199
(Constant)	.620	8.961		.069	.947
CSR disclosure	.014	.006	.818	2.365	.064
Firm revenue	-6.95	.001	-.021	-.061	.954

Note: a. Dependent Variable: Return on asset.

The P-Value for the model when ROA is used as dependent variable, CSR as dependent variable and Firm Size

as control variable is 0.030, which is less than 0.05 indicate there is significant relationship between these two variable thus we can H1a which there is significant relationship between CSR and ROA with Firm Size as control variable. This parallel with result obtains in previous analysis on H1.

However, P-Value equal to 0.074, which is more than 0.05 significance values for relation between CSR and ROA with firm revenue as control variable, indicates there is not statistically significance thus hypothesis H1b rejected. The result can be view in Table 5.

Table 5. Model summary ROA as a constant for model 2

	R	R Square	Adjusted R Square	Std. Error of the Estimate	Change Statistics				
					R Square Change	F Change	df1	df2	Sig. F Change
a	.869 <sup>a</sup>	.755	.656	.53672	.755	7.687	2	5	.030
b	.804 <sup>a</sup>	.647	.506	.64360	.647	4.584	2	5	.074

Note: a. Predictors: (Constant), No. of employee, CSR dis. B. Predictors: (Constant), Firm Revenue, CSR dis.

Proceeding analysis on model 2, this time ROE as dependent variable as depict in Table 6, show there is direct relationship between CSR and firm ROE when Firm Size and Firm Revenue used as control variable. 1 unit of ROE can be obtained by increasing 0.23 units level of CSR and without any change in Firm Size and 1 unit of ROE can be obtained by increasing 0.15 units level of CSR and 0.01 units of Firm Revenue.

Table 6. Regression result ROE as a constant for model 2

	Unstandardized Coefficients		Standardized Coefficients		t	Sig.
	B	Std. Error	Beta			
(Constant)	17.131	12.129			1.412	.217
CSR disclosure	.023	.013	1.083		1.763	.138
No of employee	.000	.001	-.218		-.355	.737
(Constant)	5.052	8.137			.621	.562
CSR disclosure	.015	.005	.719		2.812	.037
Firm revenue	.001	.001	.248		.971	.376

Note: a. Dependent Variable: Return on equity.

To test H2a and H2b hypothesis, by utilizing correlation coefficient (R) to check on the magnitude and the direction of the relationship where P-Value were used to check on the overall significance of the model, Table 7 produce P=0.024 for ROE as dependent variable, CSR as dependent variable and Firm Size as control variable, indicate there is significant relationship between this two variable. Hence the hypothesis H2a, that state there is significance relationship between CSR and ROE with Firm Size as control variable can be accepted. Meanwhile similar result obtain for relation between CSR and ROE with Firm Revenue as control variable where the P-Value is equal to 0.016 enable to accept H2b hypothesis. Significance relationship on H2a and H2b between CSR and ROE obtained from the analysis, further support the similar result obtained on test for H2.

Table 7. Model summary ROE as a constant for model 2

	R	R Square	Adjusted R Square	Std. Error of the Estimate	Change Statistics				
					R Square Change	F Change	df1	df2	Sig. F Change
a	.881 <sup>a</sup>	.776	.687	.62922	.776	8.679	2	5	.024
b	.898 <sup>a</sup>	.807	.730	.58442	.807	10.459	2	5	.016

Note: a. Predictors: (Constant), No. of employee, CSR dis. B. Predictors: (Constant), Firm Revenue, CSR dis.

## 5. Conclusion

The aim of this research is to examine the relationship between CSR and CFP. The study used regression analysis to establish the relationship between CSR and CFP of firms listed in Bursa Malaysia. Firm Size indicated by number of employee and firm Sales represent total revenue generated from company operation was using as control variables. One major finding in this study, there is positive relationship between firm financial performance measure in ROA and ROE and CSR practises together with Firm Size and Firm Revenue as control variable.

The results of this analysis indicate that firm exhibit greater concern to improve financial performance and corporate reputation via increasing their CSR or sustainability report in their annual report. This result also is in line with prior studies that found significant and positive relationship between CSR and CFP. According to Waddock and Graves (1997), the better social performance of companies would ensure greater financial performance due to these companies utilizing their financial resources, labor commitment and other interested groups efficiently. The positive relation of CSR towards firm financial performance indicates that companies could increase their external reputation. Furthermore, companies are able to increase the morale of employees and enhanced relations with investors (Waddock & Graves, 1997).

One of the limitation of this paper is on the measurement of CSR does not really implicate with the CFP. Note that the measurement of the CSR is based on the content analysis on firm reporting on workplace, marketplace, community and environment dimension. Measurement that is more appropriate is the amount of donation or amount on investment of CSR performed by the company. However, the nature of Malaysia law does not required company to disclose the amount invested into CSR in their annual report, make content analysis more viable option. Another limitation of this paper was the timeframe and the number of firms use in this study. Relatively low number of the company and short span timeframe used may not comprehensively justify the relation.

## References

- Andrew, B. H., Gul, F. A., Guthrie, J. E., & Teoh, H. Y. (1989). A note on corporate social disclosure practices in developing countries: The case of Malaysia and Singapore. *British Accounting Review*, 21(4), 371–376. [http://dx.doi.org/10.1016/0890-8389\(89\)90034-6](http://dx.doi.org/10.1016/0890-8389(89)90034-6)
- Aras, G., Aybars, A., & Kutlu, O. (2010). Investigating the relationship between corporate social responsibility and financial performance in emerging markets. *International Journal of Productivity*, 59(3), 229–254.
- Azlan, A., & Susela, S. D. (2008). The impact of government foreign affiliate influence on corporate social reporting: the case of Malaysia. *Managerial Auditing Journal*, 23(4), 386–404. <http://dx.doi.org/10.1108/02686900810864327>
- Balabanis, G., Philips, H. C., & Lyall, J. (1998). Corporate social responsibility and economic performance in the top British companies: Are they linked? *European Business Review*, 98(1), 24–44. <http://dx.doi.org/10.1108/09555349810195529>
- Barnett, M. L. (2007). Stakeholder influence capacity and the variability of financial returns to corporate social Responsibility. *Academy of Management Review*, 32(3), 794–816. <http://dx.doi.org/10.5465/AMR.2007.25275520>
- Bayoud, N. S., Kavanagh, M., & Slaughter, G. (2012). An empirical study of the relationship between corporate social responsibility disclosure and organizational performance: Evidence from Libya. *International Journal of Management and Marketing Research*, 5(3).
- Boesso, G., Kumar, K., & Michelon, G. (2013). Descriptive instrumental and strategic approaches to corporate

- social responsibility: Does they drive the financial performance of companies differently? *Accounting, Auditing & Accountability Journal*, 26(3), 399–422. <http://dx.doi.org/10.1108/09513571311311874>
- Carroll, A. B. (1979). A three-dimensional conceptual model of corporate performance. *The Academy of Management Review*, 4(4), 497–505.
- Cochran, P., & Wood, R. (1984). Corporate social responsibility and financial performance. *Academy of Management Journal*, 27(1), 42–56. <http://dx.doi.org/10.2307/255956>
- Cornell, B., & Shapiro, A. C. (1987). Corporate stakeholders and corporate finance. *Financial Management*, 16(1), 5–14. <http://dx.doi.org/10.2307/3665543>
- Dkhili, H., & Ansi, H. (2012). The link between corporate social responsibility and financial performance: The case of Tunisian companies. *Journal of Organizational Knowledge Management*, 2(4), 20–12.
- Ehsan, S., & Kaleem, A. (2012). An empirical investigation of the relationship between corporate social responsibility and financial performance (Evidence from manufacturing sector of Pakistan). *Journal of Basic and Applied Scientific Research*, 2(3), 2909–2922.
- Ghelli, C. (2013). *Corporate social responsibility and social performance: An empirical evidence*. Copenhagen Business School.
- Griffin, J. J., & Mahon, J. F. (1997). The corporate social performance and corporate financial performance debate: Twenty-five years of incomparable research. *Business & Society*, 36(1), 5–31. <http://dx.doi.org/10.1177/000765039703600102>
- Haniffa, R. M., & Cooke, T. E. (2005). The impact of culture and governance on corporate social reporting. *Journal of Accounting & Public Policy*, 24(9), 1–40.
- Iqbal, N., Ahmad, N., Basheer, N. A., & Nadeem, M. (2012). Impact of corporate social responsibility on financial performance of corporations: Evidence from Pakistan. *International Journal of Learning & Development*, 2(6). <http://dx.doi.org/10.5296/ijld.v2i6.2717>
- Karagiorgos, T. (2010). Corporate social responsibility and financial performance: An empirical analysis on Greek companies. *European Research Studies*, 11(4).
- Khanifar, H., Nazari, K., Emami, M., & Soltani, H. A. (2012). Impacts corporate social responsibility activities on company financial performance. *Interdisciplinary Journal of Contemporary Research in Business*, 3(9).
- Lioui, A., & Sharma, Z. (2012). Environmental corporate social responsibility and financial performance: Disentangling direct and indirect effects. *Ecological Economics*, 78(5), 100–111. <http://dx.doi.org/10.1016/j.ecolecon.2012.04.004>
- Lo, B. C. W., & Yap, K. L. (2011). Are Malaysian companies ready for corporate social responsibility? *Labuan e-Journal of Muamalat and Society*, 5(7), 11–15.
- McWilliams, A., & Siegel, D. (2000). Corporate social responsibility and financial performance: Correlation or misspecification? *Strategic Management Journal*, 21(5), 603–606. [http://dx.doi.org/10.1002/\(SICI\)1097-0266\(200005\)21:5<603::AID-SMJ101>3.0.CO;2-3](http://dx.doi.org/10.1002/(SICI)1097-0266(200005)21:5<603::AID-SMJ101>3.0.CO;2-3)
- Mishra, S., & Suar, D. (2010). Does corporate social responsibility influence firm performance of Indian companies? *Journal of Business Ethics*, 95(8), 571–601. <http://dx.doi.org/10.1007/s10551-010-0441-1>
- Mwangi, C. I., & Jerotich, O. J. (2013). The relationship between corporate social responsibility practices and financial performance of firm in the manufacturing, construction and allied sector of the Nairobi securities exchange. *International Journal of Business, Humanities and Technology*, 3(2).
- Nelling, E., & Webb, E. (2008). Corporate social responsibility and financial performance: the virtuous circle revisited. *Springer Science & Business Media*, 32(8), 197–209.
- Ngwakwe, C. C. (2009). Environmental responsibility and firm performance: Evidence from Nigeria *International Journal of Human and Social Sciences*, 4(6).
- Ramasamy, B., Ting, H. W., & Yeung, M. C. Y. (2007). Does it pay to be good in developing countries? The relationship between CSR and financial performance in Malaysia. *Asian Academy of Management Journal of Accounting and Finance*, 3(1), 21–36.
- Raza, A., Ilyas, M. I., Rauf, R., & Qamar, R. (2012). Relationship between Corporate Social Responsibility (CSR) and Corporate Financial Performance (CFP): Literature review approach. *Elixir Financial Management*, 46(9), 8404–8409.

- Saleh, M., Zulkifli, N., & Muhamad, R. (2011). Looking for evidence of the relationship between corporate social responsibility and corporate financial performance in an emerging market. *Asia-Pacific Journal of Business Administration*, 3(2), 165–190. <http://dx.doi.org/10.1108/17574321111169849>
- Savage, A. A. (1994). *Environmental reporting: Stakeholder's perspective*. Port Elizabeth University, Working Paper 94.
- Sun, L. (2012). Further evidence on the association between corporate social responsibility and financial Performance. *International Journal of Law and Management*, 54(6), 472–484. <http://dx.doi.org/10.1108/17542431211281954>
- Teoh, H. Y., & Thong, G. (1984). Another look at corporate social responsibility and reporting: and empirical study in a developing country. *Accounting, Organizations and Society*, 9(2), 189–206. [http://dx.doi.org/10.1016/0361-3682\(84\)90007-2](http://dx.doi.org/10.1016/0361-3682(84)90007-2)
- Uadiale, O. M., & Fagbemi, T. O. (2012). Corporate social responsibility and financial performance in developing economies: The Nigerian experience. *Journal of Economic and Sustainable Development*, 3(4).
- Uwuigbe, U., & Egbide, B. C. (2012). Corporate social responsibility disclosure in Nigeria: A study of listed financial and non-financial firms. *Journal of Management and Sustainability*, 2(1). <http://dx.doi.org/10.5539/jms.v2n1p160>
- Waddock, S. A., & Graves, S. B. (1997). The corporate social performance—financial performance link. *Strategic Management Journal*, 18(4), 303–319. [http://dx.doi.org/10.1002/\(SICI\)1097-0266\(199704\)18:4<303::AID-SMJ869>3.0.CO;2-G](http://dx.doi.org/10.1002/(SICI)1097-0266(199704)18:4<303::AID-SMJ869>3.0.CO;2-G)
- Wood, D. (1991). Corporate social performance revisited. *Academy of Management Review*, 16(5), 691–718.

### Copyrights

Copyright for this article is retained by the author(s), with first publication rights granted to the journal.

This is an open-access article distributed under the terms and conditions of the Creative Commons Attribution license (<http://creativecommons.org/licenses/by/3.0/>).