

## Downregulation of tumor-suppressor gene *LHX6* in cancer: a systematic review

EVELYN NATHALIA<sup>1,\*</sup>, MADELAINE SKOLASTIKA THEARDY<sup>1</sup>, SHARLEEN ELVIRA<sup>2</sup>, GRACIELLA ROSELLINNY<sup>1</sup>, ANDREW STEVEN LIYANTO<sup>2</sup>, MICHAEL PUTRA UTAMA<sup>2</sup>, ANTON SUMARPO<sup>1</sup>

<sup>1</sup>Department of Biomedicine, School of Life Sciences, Indonesia International Institute for Life Sciences, Jakarta, Indonesia

<sup>2</sup>Department of Biotechnology, School of Life Sciences, Indonesia International Institute for Life Sciences, Jakarta, Indonesia

**Introduction.** *LIM Homeobox 6 (LHX6)* encodes a LIM homeodomain transcription factor, contributes to tissue development and morphogenesis, and is mostly expressed in medial ganglionic eminence and odontogenic mesenchyme. However, it has been reported to play a role in cancer progression. This narrative review summarizes literatures that emphasize the molecular regulation of *LHX6* in tumorigenesis.

**Methods.** In our systematic review, the PubMed database was used for the literature search using the combination of words that included “LHX6” and “cancer”. Relevant studies, including *in vitro*, *in vivo* experiments, and clinical studies, were analyzed in this review.

**Results.** We found evidences that *LHX6* might be important in the inhibition of tumor cell proliferation, growth, invasion, and metastasis through the suppression of Wnt/ $\beta$ -catenin signaling pathway. Moreover, *LHX6* is observed to be downregulated in certain types of cancer due to hypermethylation, thus hindering its tumor suppressing ability. In addition, hypermethylation can also be used to determine the stage of cancer development.

**Conclusion.** The downregulation of LHX6 expression might be responsible in promoting cancer progression. Future studies are necessary to investigate the potential of LHX6 as a novel cancer biomarker as well as its therapeutic implications towards certain types of cancer.

**Key words:** LHX6; cancer progression; epigenetics; tumor suppressor gene; prognostic biomarker.

### INTRODUCTION

*Lim Homeobox 6 (LHX6)* is a member of LIM Homeobox gene family that is located in chromosome 9q33.2. Its regulation is mostly involved in tissue morphogenesis and development [1, 2]. In neurogenesis, LHX6 plays a significant role in the specification and migration of GABAergic cortical interneurons (CIN), specifically parvalbumin-positive (PV<sup>+</sup>) and somatostatin-positive (STT<sup>+</sup>) interneurons within the neocortex, hippocampus, and medial ganglionic eminence (MGE) [3-6]. Moreover, *in vitro* and *in vivo* studies showed that LHX6 interacts with Lim homeobox 8 (LHX8), SRY-box 2 (SOX2), and Forkhead box 1 (FOXP1) for GABAergic interneuron cell fates, migration, and globus pallidus differentiation via sonic hedgehog (SHH) signaling pathway, where it regulates the formation of CIN progenitor [7-12]. LHX6 also upregulates Aristaless related homeobox (ARX) and C-X-C chemokine receptor 7 (CXCR7) expression which eventually promote the maturation, migration and laminar positioning of cortical interneurons in MGE [10, 13, 14]. In addition, LHX6 controls numbers and types of interneurons that migrate to certain positions within the cerebral layers [15, 16].

LHX6 is known to be expressed in the odontogenesis and palatogenesis, where its interaction with  $\beta$ -catenin and lymphoid enhancer binding factor 1 (LEF-1) suppresses the activation of PITX2, which controls dental stem cell proliferation and differentiation [17-23]. Knockout of *LHX6* and *LHX8* in the dental mesenchymal region causes specification failure of the molar mesenchyme and upregulation of p57<sup>Kip2</sup>, hindering the growth of molar teeth and palatal shelves [17, 18, 23]. Several studies have reported that LHX6 also plays important roles in tumorigenesis by exerting its tumor suppressing abilities. However, its promoter hypermethylation might cause the downregulation of this gene in certain types of cancer. Therefore, our systematic review aims to provide emerging updates about LHX6 in cancer and its potential role as a tumor suppressor and prognostic biomarker.

### MATERIAL AND METHODS

#### Literature Search

This systematic review was conducted by screening and gathering results of research papers

from literature search in PubMed database. External sources were not used. Relevant studies were searched by using keywords algorithm: lhx6 [All Fields] AND (“neoplasms” [MeSH Terms] OR “neoplasms” [All Fields] OR “cancer” [All Fields]).

### Inclusion and Exclusion Criteria

The articles from the database with the keywords input were screened and analyzed (n = 15) with the Preferred Reporting Items for Systematic Reviews

and Meta-analyses (PRISMA) guidelines [24] using the following criteria: (1) original articles; (2) accessible papers; (3) published in English language; (4) published within year 2006-2017; (5) *in vitro*, *in vivo*, and clinical studies; (6) qualitative and/or quantitative results; (7) studies assessing levels of LHX6 in cancer cells and/or its mechanism as a potential tumor suppressor (Figure 1). We excluded conference abstracts, letters, and review articles. EN, MST, and SE independently examined and screened the titles and abstracts of records identified for eligibility.

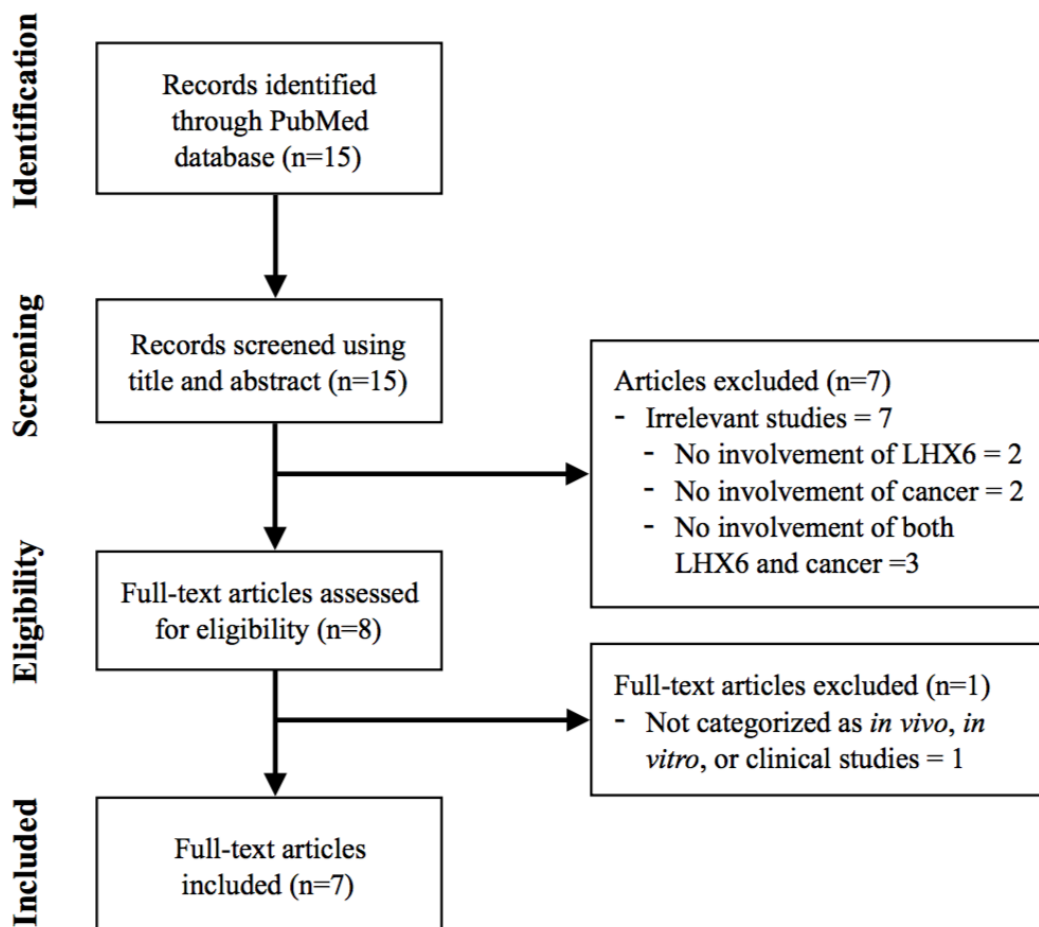

Figure 1. Methodology for paper selection according to PRISMA review guidelines.

### Data Extraction

We gathered all of the full-text articles that met the inclusion criteria. The results from 7 research articles that are relevant to this review were extracted and analyzed by EN, MST, GR, and SE. These data were further confirmed by ASL, MPU, and AS. The outcomes of the studies were comprehensively analyzed and discussed.

### RESULTS

#### Study characteristics

Studies that are used in this review are categorised as level IV evidence as they are more involved in analysis of outcomes without involving patients, focusing more on *in vitro*, *in vivo*, and clinical studies (Table 1). The studies used in this review have a low to moderate level of certainty.

However, all studies showed consistent results, including promoter hypermethylation and down-regulation of *LHX6* in various cancer types. Due to

the consistency in the results obtained, further research in regards to this topic could be performed.

*Table 1*  
Comparison of result analysis from included full-text research articles

Ref	Clinical studies: Sample characteristics	<i>In vitro</i> : cell line	<i>In vivo</i> : animal model	LHX6 expression	Mechanisms
2	Male (28/32); Female (4/32) Age: 50 (10/32); >50 (22/32) Cancer cells grade: I and II (9/32); III and IV (23/32)	HN cancer (HN 1483, FaDu, TR146, SqCC/Y1, UMSSC-10A, 10B, 11B, 14B, 17A, 17B, 22A, 22B, 35 and 38); colon cancer (RKO, DLD-I, SW480, SW837, HT-29, LoVo); breast cancer (BT-474); lung cancer (NCI-H460, NCI-H249, Hut64); leukemia (CEM, HL-60); prostate cancer (LNCap, PC-3, DU 145); liver cancer (HepG2).	-	↓	LHX6 as a new frequent cancer-associated hypermethylated CpG islands in HN tumors whose hypermethylation arises in pre-malignant tissues and can be detected in the blood plasma, possibly allowing early detection; DIME-6 hypermethylation in cancer cell lines is related to knockdown in LHX6
25	Male (47/88); Female (41/88) Age: ≤60 (39/88); >60 (49/88) Cancer cells grade: I and II (9/32); III and IV (23/32)	Human lung cancer cell lines SPC-a-1, 95D, LTEP-a-2, A549, H358 and immortalized HBE cell line	BALB/c-nude mice Age: 4 weeks Injected with LTEP-a-2 cells (n=848)	↓	Downregulation of LHX6 in lung cancer development; LHX6 is associated with poor survival rate of lung cancer patient; LHX6 is a tumor suppressor
26	Female (32/32) Age: 43-58 Cancer cells grade: N/A	Breast cancer cell lines (MCF7 and MDA-MB-231)	BALB/c nude mice Female Age: 4 weeks Injected with MDA-MB-231 cells	↓	Increased LHX6 expression reduces β-catenin expression levels; LHX6 suppresses tumor proliferation and invasion in breast cancer progression
27	Male (47/62); Female (15/62) Age: <60 (21/62); >60 (41/62) Cancer cells grade: I and II (45/62); III and IV (17/62)	Lung cancer cell lines (95D, H358, A549, H1975, SPC-A-1, H1650, LTEP, H1395, H460, HBE cells)	BALB/c nude mice Female Age: 4 weeks Injected with H358 cells	↓	LHX6 hypermethylation is related to the silencing of transcription and causes defective expression of LHX6; LHX6 is a tumor suppressor gene that reduces the formation of tumor both <i>in vitro</i> and <i>in vivo</i> ; LHX6 expression increases apoptosis and cell cycle arrest
28	Female (110/110) Age: 21-82 Cancer cells grade: I (30/110), II (30/110), III (20/110), IV (20/110)	Cervical cancer cell line (C33A, CaSki, HeLa, SiHa, SNU-17, SNU-703, SNU-1160, SNU-1299)	-	↓	hLHX6 and hLHX6.1 genes are repressed in most cervical cancer; Hypermethylation of CpG island in LHX6.1 promoter is only present in cancer cells
29	Female (110/110) Age: 21-82 Cancer cells grade: I (30/110), II (30/110), III (20/110), IV (20/110)	Cervical cancer cell line (C33A, CaSki, HeLa, SiHa, SNU-17, SNU-703, SNU-1160, SNU-1299)	-	↓	hLHX6 and hLHX6.1 genes are repressed in most cervical cancer; Hypermethylation of CpG island in LHX6.1 promoter is only present in cancer cells
30	Male (2/7), Female (5/7) Age: 44-66 Cancer cells grade: III (1/7); IV (6/7)	Erlotinib-resistant non-small-cell lung cancer (HCC827/ER cells)	-	↓	Downregulation of LHX6 involved in NSCLC development; Resistance to EGFR-TKIs mediated by miR-214 in EGFR-mutant NSCLC cell lines includes involvement of LHX6

Ref, references; ↑, upregulation; ↓, downregulation.

### *In vitro* studies

In head and neck squamous cell carcinoma (HNSCC) cell lines, cyclin D1 and cortactin are overexpressed due to the deletion of regions of tumor suppressing chromosome 3p which may cause

tumor progression [31]. The breast cancer cell lines, MCF-7 and MDA-MB-231, have been shown to have high tumorigenic potential in the presence of oestrogen [32]. In cervical cancer cell lines, chromosome 3q that was associated with the progression of tumors from high grade CIN to

invasive CC was found to be amplified [33]. In lung cancer cell lines, expression of various genes such as *LKB1* and *TITF1*, which affects lung cancer pathogenesis, is abnormal [34]. These results show that the cell lines are suitable for the research on the tumor suppressor ability of LHX6.

### ***In vivo* studies**

Three *in vivo* studies were analyzed in our review, including studies using BALB/C-nude mice to investigate LHX6 expression in lung adenocarcinoma [35] and breast cancer [36].

### **Clinical studies**

Clinical sample characteristics of the total 441 samples are described (Table 2). Age was known to have a range of 21-82 years. Gender of which clinical samples were obtained were reported in seven studies, dominated by female (72%). Primary tumor sites were mostly from cervical cancer (36%), followed by lung cancer (n = 157, 36%). Breast cancer and HNSCC shared the same amount of samples (n = 32, 7%). From the studies reported, most of the tumors were stage I-II (n = 230, 52%).

*Table 2*  
Characteristics of patients observed in various clinical studies

	Total	
	n	%
<b>Total samples</b>	<b>441</b>	<b>100</b>
Median age (years)		
<50	220	50
>50	221	50
Gender		
Male	124	28
Female	317	72
Primary tumor site		
Head neck squamous cell carcinoma	32	7
Lung cancer tissue	157	36
Squamous cell carcinoma	28	6
Adenocarcinoma	109	25
Atypical squamous cell	7	2
Small-cell lung cancer	5	1
Large-cell lung cancer	1	0.2
Non-small-cell lung cancer	7	2
Cervical cancer	220	50
Breast cancer	32	7
Tumor Stage (I-IV)		
Normal	20	5
I	87	20
II	89	20
III	68	15
IV	47	11
I and II*	230	52
III and IV**	155	35
N/A	32	7

\* Includes I, II and those reported as I-II, \*\* Includes III, IV and those reported as III-IV

## DISCUSSION

### LHX6 expression is downregulated in certain types of cancer

In physiological conditions, LHX6 is widely expressed during odontogenesis and neurogenesis. However, several studies have shown that the expression of LHX6, at both transcriptional and translational levels, is downregulated during lung adenocarcinoma and breast cancer progression [25-27]. In addition, Jung *et al.* have shown that, in cervical cancer cells, gene transcription of *hLHX6* (*Homo sapiens LIM homeobox domain 6*) and its isoform, *hLHX6.1*, were suppressed [28]. Furthermore, Yang *et al.* reported that LHX6 expression is higher in lymph node-negative patients compared to lymph node-positive patients [25]. Moreover, LHX6 expression in patients with metastatic lung cancer is downregulated [25]. Thus, in lung adenocarcinoma, breast cancer, and cervical cancer, downregulation of LHX6 might possibly contribute to the cancer progression [25-28, 30].

### LHX6 tumor suppressing ability

Cancer patients with low LHX6 expression were reported to have shorter survival rate compared to individuals that have overexpression of LHX6 [25]. Moreover, decreased LHX6 expression induced an increase in cell viability, colony formation, and growth of cancer cells *in vitro* [25, 27]. Studies performed using lung (LTEP-a-2, SPC-a-1, 95D and H358) and breast (MCF7 and MDA-MB-231) cancer cell lines showed that LHX6 inhibits cell proliferation [25-27]. In addition, increased mRNA expressions of *LHX6* and *hLHX6.1* were observed in lung (95D and H358) and cervical (SiHa) cancer cell lines, thus reduced the tumor cell colony size and number, prevented the colony formation, and decreased the ability of cancer cells to migrate and invade [25, 27, 28]. *In vivo* studies using nude mice also showed that administration of LHX6-over-expressing cells reduced tumor weight and volume and inhibited metastasis in liver cancer [25-27]. Hence, LHX6 exerts its tumor suppressive ability in both *in vivo* and *in vitro*.

### LHX6 is hypermethylated in cancer

The *hLHX6* fragments, *hLHX6-HMR* and differentially methylated 6 (*DIME6*), are located in

between exon 4a and exon 5 of *hLHX6* promoter [29]. These fragments are prone to hypermethylation, especially *DIME6* [2, 29]. This hypermethylation specifically occurs on the cytosine guanine dinucleotide (CpG) sites of these fragments, in which a methyl group is enzymatically added on the cytosines in the 5' position with respect to the guanine of the CpG site, causing epigenetic alteration [2]. The hypermethylation in the promoter region of the *hLHX6* gene might be the cause of its repressed expression [2, 29].

*hLHX6* and *LHX6* show little to no hypermethylation in normal cells. However, in early stages of cervical cancer carcinogenesis, the frequency of methylation increases alongside cancer progression [29]. *LHX6*, *hLHX6-HMR*, and *hLHX6.1* are shown to be either partially methylated or fully methylated in certain types of cancers such as lung, cervical, head, and neck cancer [26-29]. Liu *et al.* have shown that in lung cancer, the CpG island is hypermethylated, suggesting that methylation of the CpG island causes the downregulation of *LHX6* [27]. The study by Jung *et al.* further supports this hypothesis by showing that CpG-rich *hLHX6.1* promoter hypermethylation occurs in cervical cancer cells. In cervical cancer, transcriptional level of *hLHX6.1* is shown to be decreased in cells with hypermethylated *hLHX6.1* promoter [28]. Therefore, we propose that downregulation of *hLHX6* expression in cancer cells is caused by hypermethylation of the CpG island of *hLHX6* promoter.

### Molecular mechanisms of LHX6 regulation in cancer

Wnt/ $\beta$ -catenin is involved in progression of certain types of cancer such as breast cancer and lung cancer. The important regulator of this canonical pathway,  $\beta$ -catenin, is involved in a series of events which further activate the downstream genes involved in cell proliferation, cell migration, and metastasis. LHX6 reduces the expression of  $\beta$ -catenin and therefore disrupts the Wnt/ $\beta$ -catenin signaling cascade [25, 27]. LHX6 further exerts its tumor suppressing abilities by upregulating p53, a proapoptotic gene which is involved in several pathways that promote or inhibit several genes (Figure 2) [25, 27]. These genes promote apoptosis, DNA repair and inhibit cell proliferation, growth, metabolic transformation, and migration [25, 27]. Moreover, LHX6 inhibits CD44 and MMP7 which are involved in cell migration and metastasis [25, 27].

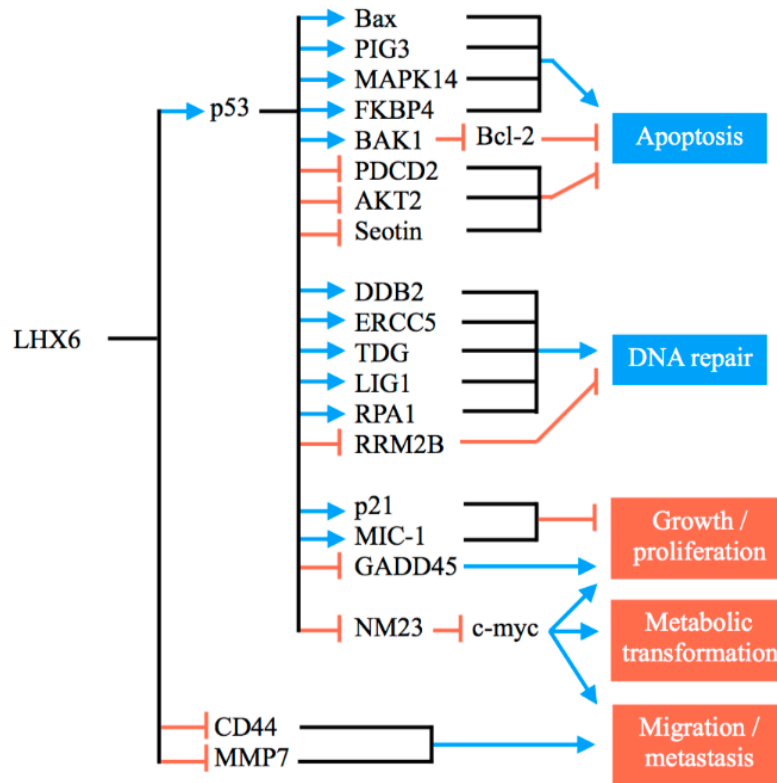

Figure 2. LHX6 regulation in tumorigenesis; stimulatory (blue) and inhibitory (red) effect.

### LHX6 expression in clinical cancer samples

*LHX6* expression was found to be down-regulated in clinical cancer samples. Promoter hypermethylation of *hLHX6.1* was observed as the normal cervical cancer cells progress into cancer cells [28]. Interestingly, *hLHX6* promoters did not show any hypermethylation in the tissue sample [28]. Jung *et al.* also found the specific CpG-island hypermethylation site in *LHX6*, *hLHX6-HMR* [29]. The analysis showed that *hLHX6-HMR* hypermethylation was also evident during carcinogenesis [29]. Moreover, the hypermethylation of *hLHX6-HMR* can be observed from the early stages of cervical cancer tumorigenesis [29]. In addition, the age of patients was correlated with the hypermethylation of *hLHX6-HMR*, which might suggest that tumor cells progress as age increases [29].

In lung cancer tissues, *LHX6* expression was downregulated in comparison to healthy lung tissues [25-27]. Furthermore, *LHX6* is hypermethylated in more than half of the clinical samples [27]. In addition, *LHX6* was observed to be specific to lung adenocarcinoma but not in squamous cell carcinoma [25]. *LHX6* also has a strong relation to cancer stage, size, and lymph node status in lung adenocarcinoma [25]. When *LHX6* expression was highly expressed

in a lymph-node negative and/or lung adenocarcinoma cancer patient, it may increase the overall survival of the patients [25]. In head and neck cancer, Estécio *et al.* showed a high amount of CpG-rich hypermethylation in DIME-6 [2]. DIME-6 is correlated to promoter region of an mRNA that possibly represents a short isoform of *LHX6*. Therefore, if DIME-6 is hypermethylated, the short isoform of *LHX6* is less likely to be present [2]. The downregulation of *LHX6* is involved in non-small-cell lung cancer (NSCLC) development [30]. *LHX6* is also found to be regulated by miR-214, one of the causes of erlotinib resistance in NSCLC [30]. However, when *LHX6* is overexpressed, miR-214 will have decreased expression which results in reversal of erlotinib resistance [30].

Taken together, downregulated *LHX6* might be present in specific cancer tissues due to its promoter methylation. The level of hypermethylation is positively correlated with cancer progression; this phenomenon might have potential as a prognostic biomarker.

### Limitations and Future Research Suggestions

The included studies involve limited types of cancers. However, some cancer cell lines have

shown possibility of *LHX6* being involved in the tumorigenesis, such as colon cancer and leukemia [2]. Hence, *LHX6* activity should be further observed in the clinical samples of these types of cancer. Another limitation is the lack of specific molecular pathways that affect the upstream and downstream of *LHX6* in its tumor suppressor activity. Hypermethylation of *hLHX6.1* has a possibility of going through epigenetic and genetic regulations that require further research [28].

## CONCLUSION

*LHX6* plays a significant role in the inhibition of tumor growth and cancer progression through

the regulation of pleiotropic mechanisms in certain cancer cells, specifically lung, breast and cervical cancer. Furthermore, downregulation of *LHX6* expression due to promoter hypermethylation might lead to accelerated tumor progression and impaired tumor suppressive abilities. Future studies are necessary to investigate the potential of *LHX6* as a novel cancer biomarker as well as its therapeutic implications by using clinical samples.

**Acknowledgments.** We express our gratitude to Yovita Hendra for the immense support and help during the writing process and to the Department of Biomedicine, Indonesia International Institute for Life Sciences (i3L) for the support in the completion of our review paper.

**Conflict of Interest:** The authors declare that there are no conflicts of interest.

---

**Introducere.** LIM Homeobox 6 (*LHX6*) codifică un factor de transcripție tip LIM și are funcție în morfogeneza fiind exprimat în cadrul mezenhimului odontogenic. Totuși, s-a observat că are un rol în progresia cancerului. Scopul acestei sinteze sistematice a fost de a trece în revistă mecanismele moleculare ale implicării *LHX6* în geneza tumorală.

**Metode.** A fost căutată baza de date Pubmed folosind o combinație de termeni dintre „*LHX6*” și „cancer”. Au fost analizate toate studiile relevante, atât cele in vitro cât și cele in vivo precum și studii clinice.

**Rezultate.** Am găsit dovezi ale implicării *LHX6* în inhibarea proliferării celulelor tumorale, în invazia tumorală sau în metastaze prin supresia căii de semnalizare Wnt/β-catenină. Mai mult decât atât, expresia *LHX6* este inhibată în cancer prin hipermetilare. În plus, gradul de hipermetilare poate fi util pentru a determina stadiul cancerului.

**Concluzii.** Inhibarea expresiei *LHX6* pare a fi responsabilă pentru progresia tumorală. Studii viitoare sunt necesare pentru a investiga potențialul pe care *LHX6* îl are ca biomarker pentru cancer precum și posibile implicații terapeutice pe care această moleculă le poate avea.

---

**Correspondence to:** Evelyn Nathalia, Department of Biomedicine, School of Life Sciences, Indonesia International Institute for Life Sciences, Jakarta, Indonesia  
Pulomas Barat Kavling 88, 13210, East Jakarta, DKI Jakarta, Indonesia  
Tel: (+62)21-295-67888  
E-mail: evelyn.nathalia@student.i3l.ac.id

## REFERENCES

- GRIGORIOU M., TUCKER AS., SHARPE PT., PACHNIS V. *Expression and regulation of Lhx6 and Lhx7, a novel subfamily of LIM homeodomain encoding genes, suggests a role in mammalian head development.* Development. 1998; **125**(11):2063-2074.
- ESTÉCIO MRH., YOUSSEF EM., RAHAL P., FUKUYAMA EE., GÓIS-FILHO JF., MANIGLIA JV., et al. *LHX6 is a sensitive methylation marker in head and neck carcinomas.* Oncogene. 2006; **25**:5018-5026.
- PERRENOUD Q., GEOFFROY H., GAUTHIER B., RANCILLAC A., ALFONSI F., KESSARIS N., et al. *Characterization of type I and type II nNOS-Expressing interneurons in the barrel cortex of mouse.* Front Neural Circuits. 2012; **6**:36.
- NEVES G., SHAH MM., LIODIS P., ACHIMASTOU A., DENAXA M., ROALFE G., et al. *The LIM homeodomain protein Lhx6 regulates maturation of interneurons and network excitability in the mammalian cortex.* Cereb Cortex. 2013; **23**(8):1811-1823.
- PASCHOU P., STYLIANOPOULOU E., KARAGIANNIDIS I., RIZZO R., TARNOK Z., WOLANCZYK T., et al. *Evaluation of the LIM homeobox genes LHX6 and LHX8 as candidates for Tourette syndrome.* Genes Brain Behav. 2012; **11**(4):444-451.
- ALIFRAGIS P., LIAPI A., PARNAVELAS JG. *Lhx6 regulates the migration of cortical interneurons from the ventral telencephalon but does not specify their GABA phenotype.* J Neurosci. 2004; **24**(24):5643-5648.

7. FLANDIN P., ZHAO Y., VOGT D., JEONG J., LONG J., POTTER G., *et al.* *Lhx6 and Lhx8 coordinately induce neuronal expression of Shh that controls the generation of interneuron progenitors.* *Neuron.* 2011; **70**(5):939–950.
8. SUSSEL L., MARIN O., KIMURA S., RUBENSTEIN JL. *Loss of Nkx2.1 homeobox gene function results in a ventral to dorsal molecular respecification within the basal telencephalon: evidence for a transformation of the pallidum into the striatum.* *Development.* 1999; **126**(15):3359–3370.
9. SANDBERG M., FLANDIN P., SILBERBERG S., SU-FEHER L., PRICE JD., HU JS., *et al.* *Transcriptional networks controlled by NKX2-1 in the development of forebrain GABAergic neurons.* *Neuron.* 2016; **91**(6):1260–1275.
10. KIM TG., YAO R., MONNELL T., CHO JH., VASUDEVAN A., KOH A., *et al.* *Efficient specification of interneurons from human pluripotent stem cells by dorsoventral and rostrocaudal modulation.* *Stem Cells.* 2014; **32**(7):1789–1804.
11. ZHAO Y., FLANDIN P., VOGT D., BLOOD A., HERMESZ E., WESTPHAL H., *et al.* *Ldb1 is essential for development of Nkx2.1 lineage derived GABAergic and cholinergic neurons in the telencephalon.* *Dev Biol.* 2014; **385**(1):94–106.
12. NAT R., SALT I., SUCIU L., STRÖM S., DECHANT G. *Pharmacological modulation of the hedgehog pathway differentially affects dorsal/ventral patterning in mouse and human embryonic stem cell models of telencephalic development.* *Stem Cells Dev.* 2012; **21**(7):1016–1046.
13. ZHAO Y., FLANDIN P., LONG JE., CUESTA MD., WESTPHAL H., RUBENSTEIN JL. *Distinct molecular pathways for development of telencephalic interneuron subtypes revealed through analysis of Lhx6 mutants.* *J Comp Neurol.* 2008; **510**(1):79–99.
14. DU T., XU Q., OCBINA PJ., ANDERSON SA. *NKX2.1 specifies cortical interneuron fate by activating Lhx6.* *Development.* 2008; **135**(8):1559–1567.
15. GEORGIEV D., GONZÁLEZ-BURGOS G., KIKUCHI M., MINABE Y., LEWIS DA., HASHIMOTO T. *Selective expression of KCNS3 potassium channel  $\alpha$ -subunit in parvalbumin-containing GABA neurons in the human prefrontal cortex.* *PLoS One.* 2012; **7**(8): e43904.
16. JAKOVCEVSKI I., MAYER N., ZECEVIC N. *Multiple origins of human neocortical interneurons are supported by distinct expression of transcription factors.* *Cereb Cortex.* 2011; **21**(8):1771–1782.
17. CESARIO JM., MALT AL., DEACON LJ., SANDBERG M., VOGT D., TANG Z., *et al.* *Lhx6 and Lhx8 promote palate development through negative regulation of a cell cycle inhibitor gene, p57Kip2.* *Hum Mol Genet.* 2015; **24**(17):5024–5039.
18. ZHAO M., GUPTA V., RAJ L., ROUSSEL M., BEI M. *A network of transcription factors operates during early tooth morphogenesis.* *Mol Cell Biol.* 2013; **33**(16): 3099–3112.
19. ZHANG Z., GUTIERREZ D., LI X., BIDLACK F., CAO H., WANG J., *et al.* *The LIM homeodomain transcription factor LHX6: a transcriptional repressor that interacts with pituitary homeobox 2 (PITX2) to regulate odontogenesis.* *J Biol Chem.* 2013; **288**(4):2485–2500.
20. DENAXA M., SHARPE PT., PACHNIS V. *The LIM homeodomain transcription factors Lhx6 and Lhx7 are key regulators of mammalian dentition.* *Dev Biol.* 2009; **33**(2):324–336.
21. ARANY S., NAKATA A., KAMEDA T., KOYOTA S., UENO Y., SUGIYAMA T. *Phenotype properties of a novel spontaneously immortalized odontoblast-lineage cell line.* *Biochem Biophys Res Commun.* 2006; **342**(3):718–724.
22. PRIAM F., RONCO V., LOCKER M., BOURD K., BONNEIFOIX M., DUCHÊNE T., *et al.* *New cellular models for tracking the odontoblast phenotype.* *Arch Oral Biol.* 2005; **50**(2):271–277.
23. ZHANG Y., MORI T., TAKAKI H., TAKEUCHI M., ISEKI K., HAGINO S., *et al.* *Comparison of the expression patterns of two LIM-homeodomain genes, Lhx6 and L3/Lhx8, in the developing palate.* *Orthod Craniofac Res.* 2002; **5**(2):65–70.
24. MOHER D., LIBERATI A., TETZLAFF J., ALTMAN DG., PRISMA GROUP. *Preferred reporting items for systematic reviews and meta-analyses: the PRISMA statement.* *PLoS Med.* 2009; **6**(7):e1000097.
25. YANG J., HAN F., LIU W., ZHANG M., HUANG Y., HAO X., *et al.* *LHX6, an independent prognostic factor, inhibits lung adenocarcinoma progression through transcriptional silencing of  $\beta$ -catenin.* *J Cancer.* 2017; **8**(13):2561–2574.
26. HU Z., XIE L. *LHX6 inhibits breast cancer cell proliferation and invasion via repression of the Wnt/ $\beta$ -catenin signaling pathway.* *Mol Med Rep.* 2015; **12**(3):4634–4639.
27. LIU W-B., JIANG X., HAN F., LI Y-H., CHEN H-Q., LIU Y., *et al.* *LHX6 acts as a novel potential tumour suppressor with epigenetic inactivation in lung cancer.* *Cell Death Dis.* 2013; **4**(10):e882.
28. JUNG S., JEONG D., KIM J., YI L., KOO K., LEE J., *et al.* *Epigenetic regulation of the potential tumor suppressor gene, hLHX6.1, in human cervical cancer.* *Int J Oncol.* 2011; **38**(3):859–869.
29. JUNG S., JEONG D., KIM J., YI L., KOO K., LEE J., *et al.* *The role of hLHX6-HMR as a methylation biomarker for early diagnosis of cervical cancer.* *Oncol Rep.* 2010; **23**(6):1675–1682.
30. LIAO J., LIN J., LIN D., ZOU C., KURATA J., LIN R., HE Z., SU Y. *Down-regulation of miR-214 reverses erlotinib resistance in non-small-cell lung cancer through up-regulating LHX6 expression.* *Sci Rep.* 2017; **7**(1):781.
31. LIN CJ., GRANDIS JR., CAREY TE., GOLLIN SM., WHITESIDE TL., KOCH WM., *et al.* *Head and neck squamous cell carcinoma cell lines: established models and rationale for selection.* *Head and Neck.* 2007; **29**(2):163–188.
32. HOLLIDAY DL., SPEIRS V. *Choosing the right cell line for breast cancer research.* *Breast Cancer Res.* 2011; **13**(4):215.
33. HARRIS CP., LU XY., NARAYAN G., SINGH B., MURTY VVVS., RAO PH. *Comprehensive molecular cytogenetic characterization of cervical cancer cell lines.* *Genes Chromosome Cancer.* 2003; **36**(3):233–241.
34. GAZDAR AF., GIRARD L., LOCKWOOD WW., LAM WL., MINNA JD. *Lung cancer cell lines as tools for biomedical discovery and research.* *J Natl Cancer Inst.* 2010; **102**(17):1310–1321.
35. NANNI P., DE GIOVANNI C., LOLLINI PL., NICOLETTI G., PRODI G. TS/A: *A new metastasizing cell line from a BALB/c spontaneous mammary adenocarcinoma.* *Clin Exp Metastasis.* 1983; **1**(4):373–380.
36. GHARIB A., FAEZIZADEH Z., MESBAH-NAMIN SAR., SARAVANI R. *Experimental treatment of breast cancer-bearing BALB/c mice by artemisinin and transferrin-loaded magnetic nanoliposomes.* *Pharmacogn Mag.* 2015; **11**(Suppl 1):S117–S122.