

# DS/CDMA Multiuser Detection with Evolutionary Algorithms

**Fernando Ciriaco**

(State University of Londrina – UEL, Brazil  
fernandociriaco@sercomtel.com.br)

**Taufik Abrão**

(State University of Londrina – UEL, Brazil  
taufik@uel.br)

**Paul Jean E. Jeszensky**

(Polytechnic School of São Paulo University – EPUSP  
pjj@lcs.poli.usp.br)

**Abstract** This work analyses two heuristic algorithms based on the genetic evolution theory applied to direct sequence code division multiple access (DS/CDMA) communication systems. For different phases of an evolutionary algorithm new biological processes are analyzed, specially adapted to the multiuser detection (MuD) problem in multipath fading channels. Monte Carlo simulation results show that the detection based on evolutionary heuristic algorithms is a viable option when compared with the optimum solution (ML - maximum likelihood), even for hostile channel conditions and severe system operation. Additionally, a comparative table is presented considering the relation between bit error rate (BER) and complexity as the main analyzed figure of merit. Each algorithm complexity is determined and compared with others based on the required number of computational operations to reach the optimum performance and also the spent computational time.

**Key Words:** genetic algorithm, evolutionary computation, multiuser detection, code division multiple access

**Category:** D.2.2, J.2

## 1 Introduction to Heuristic Algorithms

In the last five years the literature has collected many proposals of solutions based on heuristic algorithms, particularly the evolutionary ones, for inherent problems to the multiple access communication, among them can be detached: the optimum detection problem (optimum performance) [Tan, 2001], [Yen and Hanzo, 2001], [Abedi and Tafazolli, 2001], [Wu et al., 2003], [Lim et al., 2003], [Lim and Venkatesh, 2004], [Abrão et al., 2004], [Yen and Hanzo, 2004], the sequences selection [Jeszensky and Stolfi, 1998], [Kuramoto et al., 2004], the parameters estimation, in special the channel coefficients estimation [Yen and Hanzo, 2001], the power control problem and the rate allocation and throughput optimization [Moustafa et al., 2004], in order to increase DS/CDMA communication systems capacity and performance. Evolutionary strategies are very effi-

cient in attaining near-optimum solutions and significantly faster than conventional point-by-point exhaustive search techniques, especially in large solution spaces.

### 1.1 The MuD Problem

In a DS/CDMA system the signal is received and detected by a matched filters bank (MFB), which constitutes the conventional detector, Figure 1. This type of receiver is unable to recover the signal in an optimum sense, independently if the channel is additive white Gaussian noise (AWGN), flat or frequency selective, because the DS/CDMA signal is affected by multiple access interference (MAI) and by the near-far ratio (NFR), resulting in a capacity well beyond the channel capacity. One of the manners to reduce these effects in order to increase capacity is to use all signals information from all other users in the detection process of the desired user. This strategy is known as MuD [Verdú, 1986], [Verdú, 1998].

In the last two decades, a great variety of multiuser detectors were proposed in the literature with the intention of performance improving compared to the conventional detection. The best possible performance is obtained with the optimum detector, however with a high computational complexity.

The optimum multiuser detector (OMuD) [Verdú, 1986], [Verdú, 1998] consists of a bank of matched filters followed by a maximum likelihood sequence estimator, MLSE. The MLSE detector generates a maximum likelihood sequence  $\hat{\mathbf{b}}$  in relation to the transmitted sequence. The vector  $\mathbf{b}$  is estimated in order to maximize the sequence transmission probability given that  $r(t)$  was received, where  $r(t)$  is extended for all message and considering all transmitted messages with the same transmission probability. The OMuD has a computational complexity that is exponentially crescent with the number of users. Hence, the OMuD is impractical to implement. Thereby, more research is necessary in order to obtain sub-optimum multiuser detectors with high performance and low complexity. Some alternatives to OMuD include the classic linear multiuser detectors, as Decorrelator [Verdú, 1986], and MMSE [Poor and S.Verdú, 1997], and the classic non-linear multiuser detectors, as Interference Cancellation (IC) [P.Patel and Holtzman, 1994] and Zero-Forcing Decision Feedback [Duel-Hallen, 1995], and also the MuD based on Classic heuristics [Tan, 2001], Stochastic [Lim et al., 2003] and Analog [Lim and Venkatesh, 2004], [Abrão et al., 2004], [Yen and Hanzo, 2004].

In this work sub-optimum heuristic evolutionary solutions will be analyzed for the MuD problem, evidencing the advantage of these solutions in contrast to the OMuD solution. For most of the practical cases of engineering interest, MuD based on heuristic techniques result in almost optimum performance, i.e., very close to the performance reached by the OMuD, however with the advantage of

smaller computational cost and a smaller detection time, an attractive tradeoff between convergence speed and complexity.

In the literature in spite of existence of several works using approximative procedures for the sub-optimum MuD, most of investigations are restricted to very simple channels for most of the communication systems, e.g., AWGN synchronous channels [Wu et al., 2003]. For instance, very few works analyze the detection problem in frequency selective channels [Abedi and Tafazolli, 2001], [Yen and Hanzo, 2004].

The first GA-based multiuser detector (GA-MuD) was proposed by Juntti *et al.* [Juntti et al., 1997], where the analysis was based on a synchronous CDMA system communicating over an AWGN channel. It was found that good initial guesses of the possible solutions are needed for the GA in order to obtain a high performance. However, by incorporating an element of local search prior to the GA-MuD, in [Yen and Hanzo, 2000] was showed that the performance of the GA-MuD approaches the single-user bound performance with a significantly lower computational complexity than that of the OMuD. Recently, the Evolutionary Programming (EP) algorithm was used for the first time for the MuD problem (EP-MuD) over AWGN synchronous channel [Lim et al., 2003]. Next, Abrão *et al.* [Abrão et al., 2004] suggest a modified version for the EP-MuD algorithm including cloning and adaptive mutation procedures for the same MuD problem.

In [Yen and Hanzo, 2004] Yen *et al.* extend the results of [Yen and Hanzo, 2001] to an asynchronous DS/CDMA system transmitting over 2-path Rayleigh fading channels with equal energy paths based on GA-MuD. For detector complexity reduction and to concomitantly decrease the detection time, the authors applied the observed window truncation technique such that it encompasses at most one complete symbol interval of all users in any detection window. Then, both the “edge” bits as well as the desired bits within the truncated observation window bits are tentatively estimated using GA strategy.

Differently of [Yen and Hanzo, 2004], this work uses one-shot evolutionary MuD over all bits from all users in the same frame, considering multipath exponential power-delay profile channels. Two evolutionary algorithms were analyzed, GA-MuD and EP-MuD with a multipath diversity smaller or equal to the number of multipaths. Additionally, the Maximal Rate Combining (MRC) was used in order to find the initial candidate bits.

The remainder of this work is organized as follows. Section 2 describes the DS/CDMA mathematical model over multipath Rayleigh channel and also the MuD problem to be optimized. Next in 3 the two algorithms pseudo-codes, based on the theory of genetic evolution and used for the MuD problem, are described and characterized. From numerical results, section 4 compares the algorithms efficiency for signals detection and different system conditions. The evolutionary algorithms efficiency is expressed in a performance term, considering BER

versus computational complexity. The computational complexity is expressed as the number of operations as well as computational time to reach the OMuD performance (or very close to it). Section 5 shows the general expressions for algorithms computational complexity, with the number of operations and computational time for each detector as a function of specific parameters. Finally section 6 synthesizes the main conclusions of this work.

## 2 System Model

In a DS/CDMA system with binary phase-shift keying modulation (BPSK) shared by  $K$  asynchronous users, as illustrated in Figure 1, the  $k$ -th user transmitted signal is given by:

$$x_k(t) = \sqrt{2P_k} \sum_i b_k^{(i)} s_k(t - iT_b) \cos(\omega_c t) \quad (1)$$

where  $P_k = A_k^2/2$  represents the  $k$ -th user' transmitted power;  $b_k^{(i)}$  is the  $i$ -th BPSK symbol with period  $T_b$ ;  $\omega_c$  is the carrier frequency;  $s_k(t)$  corresponds to the spreading sequence defined in the interval  $[0, T_b)$  and zero outside:

$$s_k(t) = \sum_{n=0}^{N-1} p(t - nT_c) \underline{s}_{k,n} \quad (2)$$

where  $\underline{s}_{k,n} \in \{-1; 1\}$  is the  $n$ -th chip of the sequence with length  $N$  used by the  $k$ -th user;  $T_c$  is the chip period and the spread spectrum processing gain,  $\frac{T_b}{T_c}$ , is equal to  $N$  (short codes); the pulse shaping  $p(t)$  is assumed rectangular with unitary amplitude in the interval  $[0; T_c)$  and zero outside.

Assuming a frame with  $I$  bits for each user, propagating over  $L$  independent slow Rayleigh fading paths, the baseband received signal<sup>1</sup> in the base station is

$$r(t) = \sum_{i=0}^{I-1} \sum_{k=1}^K \sum_{\ell=1}^L A_k b_k^{(i)} s_k(t - \tau_{k,\ell}) * h_k^{(i)}(t) + \eta(t) \quad (3)$$

where  $K$  is the number of active users,  $t \in [0, T_b]$ , the amplitude  $A_k$  is assumed as constant for all  $I$  transmitted bits,  $b_k \in \{-1, +1\}$  is the transmitted information bit,  $s_k$  is a copy of the signature sequence assigned to the  $k$ -th user, with  $\tau_{k,\ell}$  representing the random delay associated to the  $k$ -th user; this random delay takes into account the asynchronous nature of the transmission,  $d_k$ , as well as the propagation delay,  $\Delta_{k,\ell}$  for  $k$ -th user,  $\ell$ -th path, resulting in  $\tau_{k,\ell} = \Delta_{k,\ell} + d_k$ ;  $\eta(t)$  represents the AWGN with bilateral power density equal to  $N_0/2$  and the complex low-pass impulse response of the channel for the  $k$ -th user over the  $i$ -th bit interval can be written as:

$$h_k^{(i)}(t) = \sum_{\ell=1}^L c_{k,\ell}^{(i)} \delta(t - \Delta_{k,\ell}) = \sum_{\ell=1}^L \beta_{k,\ell}^{(i)} e^{j\phi_{k,\ell}^{(i)}} \delta(t - \Delta_{k,\ell}) \quad (4)$$

<sup>1</sup> Assuming ideal low-pass filtering.

where  $c_{k,\ell}$  is the complex channel coefficient for the  $k$ -th user,  $\ell$ -th path; it is assumed that the  $c_{k,\ell}$  phase has a uniform distribution over  $\phi_{k,\ell} \in [0, 2\pi)$  and the channel coefficient's amplitude  $\beta_{k,\ell}$  represents the small scale-fading envelope following a Rayleigh distribution with probability density function (PDF):

$$f(\beta) = \frac{2\beta}{\varsigma} e^{-\frac{\beta^2}{\varsigma}} \quad (5)$$

where  $\beta$  is the coefficient's module and  $\varsigma$  the multipath's component average power  $\varsigma = E[\beta^2]$ . Additionally, it is assumed that the channel gain is normalized for all users:

$$E \left[ \sum_{\ell=1}^L |c_{k,\ell}|^2 \right] = 1, \text{ for } k = 1, 2, \dots, K \quad (6)$$

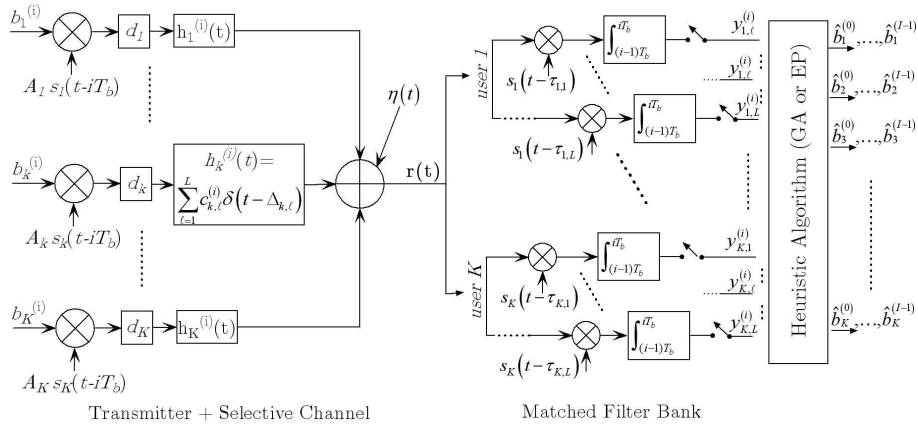

Figure 1: Baseband DS/CDMA Block Diagram, detaching the asynchronous transmission and the conventional receiver for frequency selective channels, used for initial estimates of the heuristic algorithms (GA and EP).

Using vectorial notation, equation (3) can be stated as:

$$r(t) = \sum_{i=0}^{I-1} \mathbf{s}^T(t - iT_b) \mathbf{a} \mathbf{c}^{(i)} \mathbf{b}^{(i)} + \eta(t) \quad (7)$$

where:  $\mathbf{s}(t) = [s_1(t - \tau_{1,1}), s_1(t - \tau_{1,2}), \dots, s_1(t - \tau_{1,L}), \dots, s_k(t - \tau_{k,\ell}), \dots, s_K(t - \tau_{K,L})]^T$  is the users signature sequence vector, the diagonal matrix for the average received users' amplitude including the path losses and shadowing effects is  $\mathbf{a} = \text{diag}[\sqrt{P_1} \mathbf{I}, \sqrt{P_2} \mathbf{I}, \dots, \sqrt{P_K} \mathbf{I}]$ , where  $\mathbf{I}_{L \times L}$  is the identity matrix with dimension  $L$ ;  $\mathbf{c}^{(i)} = \text{diag}[c_{1,1}^{(i)}, \dots, c_{1,L}^{(i)}, c_{2,1}^{(i)}, \dots, c_{2,L}^{(i)}, \dots, c_{K,L}^{(i)}]$  is the diagonal channel gain matrix, and the data vector is given by  $\mathbf{b}^{(i)} = [\mathbf{b}_1^{(i)}, \mathbf{b}_2^{(i)}, \dots, \mathbf{b}_K^{(i)}]^T$  with  $\mathbf{b}_k^{(i)}$  representing the  $1 \times L$   $k$ -th user bit vector. For simplicity and without

loss of generality, it was assumed an ordering of the random delays, such that  $0 \leq \tau_{1,1} \leq \tau_{1,2} \leq \dots \leq \tau_{1,L} \leq \tau_{2,1} \leq \dots \leq \tau_{K,L} < T_b$ . For multipath fading channels, the conventional receiver (Rake) consists of a bank of  $KL$  filters matched to the users signature sequence. The matched filter outputs with coherent reception for the  $k$ -th user corresponding to the  $\ell$ -th multipath component (finger) sampled at the end of the  $i$ -th bit interval can be expressed as

$$y_{k,\ell}^{(i)} = \int_{-\infty}^{+\infty} r(t) s_k(t - iT_b - \tau_{k,\ell}) dt = \sqrt{P_k} T_b \beta_{k,\ell}^{(i)} b_k^{(i)} + SI_{k,\ell}^{(i)} + I_{k,\ell}^{(i)} + n_{k,\ell}^{(i)} \quad (8)$$

where the first term corresponds to the desired signal, the second to the auto-interference, the third to the MAI over the  $\ell$ -th multipath component of  $k$ -th user and the last to the filtered AWGN.

The output of the matched filter bank at the  $i$ -th symbol interval can be written using vector notation as:

$$\begin{aligned} \mathbf{y}^{(i)} &= \left[ y_{1,1}^{(i)}, y_{1,2}^{(i)}, \dots, y_{1,L}^{(i)}, y_{2,1}^{(i)}, \dots, y_{2,L}^{(i)}, \dots, y_{K,L}^{(i)} \right]^T \\ &= \mathbf{R}^T [1] \mathbf{a} \mathbf{c}^{(i+1)} \mathbf{b}^{(i+1)} + \mathbf{R} [0] \mathbf{a} \mathbf{c}^{(i)} \mathbf{b}^{(i)} + \mathbf{R} [1] \mathbf{a} \mathbf{c}^{(i-1)} \mathbf{b}^{(i-1)} + \mathbf{n}^{(i)} \end{aligned} \quad (9)$$

where the matrices  $\mathbf{R} [0]$  and  $\mathbf{R} [1]$  with  $LK \times LK$  dimension are defined by the elements:

$$R_{jk} [0] = \begin{cases} 1 & , \text{ if } j = k \\ \mathcal{R}_{jk}(\tau_{jk}, 0) & , \text{ if } j < k \\ \mathcal{R}_{kj}(\tau_{jk}, 0) & , \text{ if } j > k \end{cases} \quad \text{and} \quad R_{jk} [1] = \begin{cases} 0 & , \text{ if } j \geq k \\ \mathcal{R}_{kj}(\tau_{jk}, 0) & , \text{ if } j < k \end{cases} \quad (10)$$

with the partial cross-correlation elements  $\mathcal{R}_{jk}$  given by:

$$\mathcal{R}_{j,k}(\tau, i) = \int_0^{T_b} s_j(t) s_k(t + iT_b + \tau) dt, \quad \text{with } i = 0; \quad (11)$$

and the filtered noise vector  $\mathbf{n}^{(i)}$  has autocorrelation matrix

$$\mathbb{E} \left[ \mathbf{n}^{(i)} \mathbf{n}^{(j)T} \right] = \begin{cases} 0.5 N_0 \mathbf{R}^T [1] & , \text{ if } j = i + 1; \\ 0.5 N_0 \mathbf{R} [0] & , \text{ if } j = i; \\ 0.5 N_0 \mathbf{R} [1] & , \text{ if } j = i - 1; \\ \mathbf{0} & , \text{ otherwise.} \end{cases} \quad (12)$$

The conventional detector for frequency selective channels consists in combining the available MFB outputs of each user (fingers) in a coherent way and weighting it by each channel gain [Proakis, 1989]. The MRC combines the  $D$  correlators' output signals, followed by an abrupt decision circuit:

$$z_k^{(i)} = \sum_{\ell=1}^D \text{Re} \left\{ y_{k,\ell}^{(i)}(s) \hat{\beta}_{k,\ell}^{(i)} \right\} \quad (13)$$

$$\hat{b}_k^{(i)} = \text{sign} \left( z_k^{(i)} \right) \quad (14)$$

where  $D \leq L$  represents the number of correlators in the receiver for each user, also named Rake diversity, which in a real system needs the estimation of the following parameters for all users: channel coefficients,  $\hat{\beta}$ , power,  $\hat{P}$ , delay,  $\hat{\tau}$ , (and therefore correlations,  $\hat{\mathcal{R}}$ ), and phase,  $\hat{\phi}$ . The Rake receiver performance will be degraded when the number of users increases (increasing the MAI) and/or when the power of interference increases (near-far effect).

One possible solution is to adopt joint decision using multiuser strategies. The best one from this class is the maximum likelihood sequence detector. Jointly optimum decisions are obtained by the OMuD that selects the most likely sequence of transmitted bits given the observations at receiver. Note that for any joint decision strategy made on the  $i$ -th bits of the  $K$  users has to take into account at least the decisions on either the  $(i - 1)$ -th bit or the  $(i + 1)$ -th of the each user. For the joint decision of all bits from all users it is adopted the one-shot approach in asynchronous channels [Verdú, 1998]. In this context the  $K$ -user,  $L$ -paths,  $I$ -frame and asynchronous channel scenario can be viewed as a  $KLI$ -user synchronous channel scenario, and then the  $KLI$ -user vector  $\mathcal{B}$  can be written as:

$$\mathcal{B} = \left[ \mathbf{b}^{(0)T}, \mathbf{b}^{(1)T}, \mathbf{b}^{(2)T}, \dots, \mathbf{b}^{(I-1)T} \right]^T \quad (15)$$

The objective is to compute the  $KLI$ -vector  $\mathcal{B}$  that maximizes [Verdú, 1998]

$$g \{ y(t), t \in [0, (I - 1) T_b] \mid \mathcal{B} \} = \exp \left( - \int_0^{(I-1)T_b} [y(t) - S(\mathcal{B})]^2 dt \right) \quad (16)$$

where:

$$S(\mathcal{B}) = \sum_{i=0}^{I-1} \sum_{k=1}^K \sum_{\ell=1}^L \sqrt{P_k} b_k^{(i)} s_k(t - \tau_{k,\ell}) \quad (17)$$

Based on the matched filter observations, vector  $\mathbf{y}^{(i)}$  in (9), the maximization of (16) is equivalent to select the vector  $\mathcal{B}$  that maximizes the so-called log-likelihood function (LLF) [Verdú, 1998]

$$\Omega(\mathcal{B}) = 2\text{Re} \{ \mathcal{B}^T \mathcal{C}^H \mathcal{A} \mathcal{Y} \} - \mathcal{B}^T \mathcal{C} \mathbf{R} \mathcal{C}^H \mathcal{B} \quad (18)$$

where the coefficients and amplitudes diagonal matrices, with dimension  $KLI$ , are defined by  $\mathcal{C} = \text{diag} [\mathbf{c}^{(0)}, \mathbf{c}^{(1)}, \mathbf{c}^{(2)}, \dots, \mathbf{c}^{(I-1)}]$  and  $\mathcal{A} = \text{diag} [\mathbf{a}, \mathbf{a}, \mathbf{a}, \dots, \mathbf{a}]$ , respectively,  $\mathcal{Y} = \left[ \mathbf{y}^{(0)T}, \mathbf{y}^{(1)T}, \mathbf{y}^{(2)T}, \dots, \mathbf{y}^{(I-1)T} \right]^T$ , the transposed hermitian operator is  $(\cdot)^H = [(\cdot)^*]^T$  and the block-tridiagonal, block-Toeplitz cross correlation matrix  $\mathbf{R}$ , with the same dimension, can be defined as [Verdú, 1998]:

$$\mathbf{R} = \begin{bmatrix} \mathbf{R}[0] & \mathbf{R}^T[1] & \mathbf{0} & \cdots & \mathbf{0} & \mathbf{0} \\ \mathbf{R}[1] & \mathbf{R}[0] & \mathbf{R}^T[1] & \cdots & \mathbf{0} & \mathbf{0} \\ \mathbf{0} & \mathbf{R}[1] & \mathbf{R}[0] & \cdots & \mathbf{0} & \mathbf{0} \\ \cdots & \cdots & \cdots & \ddots & \cdots & \cdots \\ \mathbf{0} & \mathbf{0} & \mathbf{0} & \cdots & \mathbf{R}[1] & \mathbf{R}[0] \end{bmatrix} \quad (19)$$

Therefore, the complete frame with the estimated transmitted bits for all of  $K$  users can be obtained with the optimization of (18), resulting:

$$\hat{\mathbf{b}} = \arg \left\{ \max_{\mathcal{B} \in \{+1, -1\}^{I \cdot K}} [\Omega(\mathcal{B})] \right\} \quad (20)$$

The OMuD try to find the best vector of data bits in a set with all possibilities, so is a NP-complete problem where the traditional algorithms are inefficient. Restricting the search space, all heuristic algorithms try to find a solution following an objective function (fitness value), which is able to quantify the improvement tendency for better solutions in the optimum solution direction. For MuD in frequency selective channels the fitness value can be expressed as (18). Therefore, each heuristic algorithm will maximize the LLF testing distinct frames of candidate bits in each new iteration. These attempts try to maximize the DS/CDMA mean performance, with  $K$  active users. Increasing the number of attempts the performance reaches that of the OMuD.

In Figure 1, MFB followed by the heuristic algorithm compose the receiver. For frequency selective channels the MFB should be extended in order to include delayed versions of the original signal from each user due to the multipath effect. In this work, for frequency selective channels, the adopted Rake combining rule is the MRC, equation (13).

### 3 Evolutionary Heuristics

This section presents an evolutionary algorithms revision, specifically GA and EP, describing its variants, focusing on the MuD for DS/CDMA communication systems. These variants include the population initialization stage, evaluation, reproduction (competition), genetic operators (mutation and crossover), the replacement stage and stop criteria for the algorithm.

For the MuD problem the total search universe is characterized by all possible combination of data bits that users can be transmitting. Considering  $K$  active users transmitting  $I$  bits through a multipath channel with  $L$  paths and with  $D$  fingers in the receiver, the total search universe will be:

$$\Theta(K, I, D) = 2^{K \cdot I \cdot D} \quad (21)$$



with  $D \geq 1$  and not necessarily  $D \leq L$ . But obviously the search universe is smaller than  $2^{K \cdot I \cdot D}$ , because each transmitted bit should be detected as the same bit for all of the  $D$  processing branches:

$$\widehat{b}_{k,1}^{(i)} = \widehat{b}_{k,2}^{(i)} = \dots = \widehat{b}_{k,D}^{(i)} \in \{+1, -1\} \quad (22)$$

Which means that the search universe for the evolutionary algorithms for the MuD problem is independent of the number of paths, resulting in  $\Theta(K, I) = 2^{K \cdot I}$ . All candidate vectors that obey equation (22) form the universe of all possible solutions. Other possibilities belong to a forbidden universe and will not be tested by the algorithms. This procedure guarantees the final solution quality allowing that a possible correct bit estimation for all paths can be done.

### 3.1 Population Size

For solutions via genetic algorithms, the population size choice is an important factor for the computational cost and the solution quality determination. With a small population the performance can be prejudiced because the population covers only a small part of the total search universe. A great population usually supplies a representative covering for the problem, besides preventing premature convergences for local solutions instead of global ones. However, in order to work with great populations, large computational resources are necessary or that the algorithm works along a very long and unnecessary period of time.

The most appropriate population size for each type of optimization problem seeking computational cost minimization is an interesting research topic that has been studied since the pioneering work of Holland [Holland, 1975]. Recently, Ahn and Ramakrishna [Ahn and Ramakrishna, 2002] extended the study accomplished in [Harik et al., 1999] finding a more flexible and easy general expression for the population size,  $p$ , without signal and noise characteristics knowledge, besides making possible its use in problems of variable sizes. This expression needs only the basic information of the problem, as alphabet cardinality ( $\chi$ ), order of the building block ( $k$ ), with  $m = \frac{l}{k} - 1$  and  $l$  is the individual's size,  $\alpha = 1 - P_b$  is the failing probability of the genetic algorithm in the decision stage and  $P_b$  is the success probability, being given by:

$$p = -\frac{\chi^k}{2} \ln(\alpha) \left( \frac{\chi^k - 1}{2} \sqrt{\pi m} + 1 \right) \quad (23)$$

This work uses equation (23) in order to find the size of the population adapted for the DS/CDMA MuD problem because is versatile, can be calculated in the genetic algorithm initialization stage and maintained constant in all generations. Rewriting equation (23) for the multiuser binary detection problem:

$$p = -\ln(\alpha) \left( 0.5 \sqrt{\pi (K \cdot I - 1)} + 1 \right) \quad (24)$$

In this work  $P_b = 99.9\%$  was considered as being the maximum success percentage and a population size entirely with multiplicity 10. Rewriting (24) results:

$$p = 10 \cdot \left\lceil 0.3454 \left( \sqrt{\pi (K \cdot I - 1)} + 2 \right) \right\rceil \quad (25)$$

where the operator  $\lceil x \rceil$  returns the smallest integer contained in  $x$ . Figure 2 synthesizes the behavior of equation (24) for various values of  $P_b$  and  $K \cdot I$ , as also the population size obtained through (25). Note that (25) guarantees a confidence greater than 99% for any value of  $K \cdot I$  and between 99.8% to 99.9% for  $K \cdot I > 22$ .

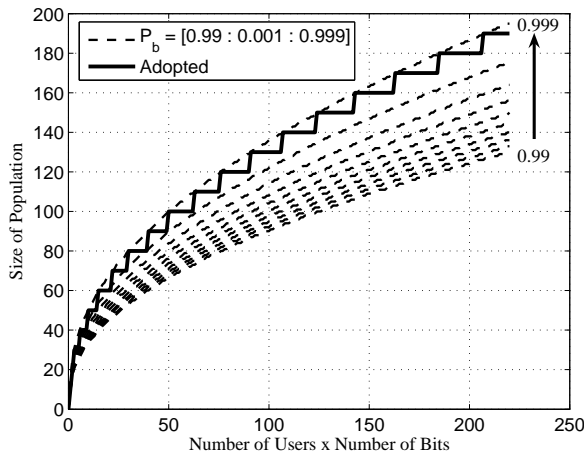

**Figure 2:** Equation (24) and the adopted population size.

### 3.2 Individual Initialization

For the MuD problem the estimates from the Rake receiver outputs is adopted as an initial individual of the population and the other members of the first population can be randomly generated or obtained from the initial individual with convenient perturbations (see section 3.5.2) [Yen and Hanzo, 2000], [Wu et al., 2003], [Abrão et al., 2004], [Yen and Hanzo, 2004]. In the literature is common to find works that use another type of detector as initial estimate for the evolutionary algorithm. This strategy decreases the number of needed generations of the evolutionary algorithm to reach the global solution, but in compensation, these detectors usually have a high complexity, not bringing gains in the system global complexity reduction [Wu et al., 2003]. In this work the outputs of the conventional detector are used as initial estimates:

$$\mathcal{B}_1 = \left[ \hat{\mathbf{b}}^{(0)T}, \hat{\mathbf{b}}^{(1)T}, \dots, \hat{\mathbf{b}}^{(I-1)T} \right]^T \quad (26)$$

where from (14) we have  $\hat{\mathbf{b}}^{(i)} = \text{sign}(\mathbf{z}^{(i)})$ . The other terms are obtained through the initial individual ( $\mathcal{B}_1$ ) with mutation operator, section 3.5.2.

### 3.3 Evaluation

It is necessary to find a value associated with each individual performance through the fitness value (aptitude measure). The aptitude is an intrinsic characteristic of each individual. At biological level it indicates the individual aptitude to survive in touch with predators, pests and other obstacles for subsequent reproduction. Transporting the concept to the mathematical algorithm it represents its aptitude in order to produce the best solution. In the MuD context this aptitude is measured through the LLF function, equation (18), and it is directly responsible for the death or life of individuals [Verdú, 1998].

### 3.4 Reproduction

The reproduction in an evolutionary algorithm is a process in which the individuals, or candidate vectors, are copied in accordance with the associated fitness values. Individuals with high fitness values have greater probability in order to form the next generation. This operator is an artificial model for the natural selection.

#### 3.4.1 Mating Pool Size

The mating pool size ( $T$ ) controls the pressure in the competition process among individuals. Certainly with a small value of  $T$  the best parents will be selected, however, the search universe diversification will diminish and the chance for a local solution increases. With a large value for  $T$  parents with smaller aptitude will be selected and their bad characteristics will be maintained in the next generations, bringing slowness to the convergence [Yen and Hanzo, 2004], [Mitchell, 1998]. The  $T$  value should be selected in order to guarantee the convergence velocity and the quality of the final solution. The mating pool size should be in the range  $2 \leq T \leq p$ . For the MuD problem  $T = 0.1p$  was adopted.

#### 3.4.2 Selection Method

The selection process determines how the parents will be chosen in order to form the next generation and how many offsprings each parent will generate. The selection strategy should be selected in a manner well adjusted to the mutation and crossover operators in order to obtain an adequate balance between exploitation and exploration. One of the more traditional selection processes used for the GA algorithm, originally proposed by [Holland, 1975], selects the parents in direct proportion with the fitness value, named Roulette Wheel sampling. Each individual is assigned a slice of a circular “Roulette Wheel” and the size of the slice being proportional to the individuals fitness. The wheel is spun  $T$  times. On each

spin, the individual under the wheel's marker is selected to be a parent for the next generation. The steps for this method are: a) sum the fitness values for all population members,  $\Omega_T = \sum_{i=1}^p \Omega(i)$ ; b) generate a random number  $x$  uniformly distributed on  $[0, \Omega_T]$ ; c) select the  $k$ -th member that satisfies  $\sum_{i=1}^k \Omega(i) \geq x$ .

This method confers priority to individuals that have bigger fitness because its selection probabilities are proportional to their aptitudes, corresponding to a bigger area in the wheel.

The selection strategy for the EP algorithm is simpler than for the GA, because in this case the best  $T$  individuals from the population  $p$  are selected as the parents for the next generation [Fogel, 1994]. The  $T$  individuals with the largest fitness scores are selected while the  $p - T$  individuals with low fitness scores are removed for the next generation. In the sequel, this strategy will be named as  $p$ -Sort selection.

A fair comparison between these two strategies, when applied to the MuD problem is presented in section 4. The convergence results, shown in Figure 4 detach the  $p$ -Sort strategy superiority in comparison with the Roulette Wheel, and therefore it will be adopted in the two algorithms analyzed in this work.

### 3.5 Genetic Operators

The genetic operators are necessary for the population diversification and also in order to maintain the adaptation characteristics acquired in previous generations. The GA algorithm uses the crossover operator as its main genetic operator with the objective of to obtain search variability but without loss of the acquired characteristics. The mutation is not considered essential because in a real population the mutation rate is low, so it is only a secondary mechanism for the genetic algorithm adaptation. For the EP algorithm the only genetic operator (besides selection) is mutation, not existing crossover. This is one of the main differences between algorithms GA and EP.

#### 3.5.1 Crossover Operator

The crossover operator combines parts from the two parents in order to produce offsprings that present genetic material from both parents. The literature presents numberless variations for the crossover operator implementation, among them the single-point crossover, multi-point cross-over and uniform crossover are the most known and used. In this work the uniform crossover was adopted.

The uniform crossover operator considers each gene (locus) as a potential point for crossover occurrence, which is controlled by the crossover mask. The crossover mask is a sequence consisting of a random binary string ("1" and

“0”) with the same length as the individuals, where each position in the mask corresponds to one bit of the individuals. A change is done for all positions with “1” in the mask and no change for “0” [Mitchell, 1998].

### 3.5.2 Mutation Operator

The mutation operator consists in a change in the individual’s characteristics. These changes are necessary for introducing and maintaining genetic diversity, changing arbitrarily one or more components of the selected structure. One manner to implement the mutation is generating a perturbation (noise), which will be added to each gene. For a bipolarized binary alphabet,  $-1$  e  $+1$ , the gene mutation will not occur if the perturbation is small [Lim et al., 2003], [Abrão et al., 2004]. However, when the perturbation is large enough in order to change the gene signal, mutation will occur. This noise can be selected following some specific statistical distribution. In this work the Gaussian distribution was adopted:

$$\text{new}_{\text{individual}} = \text{sign}(\text{individual} + \mathcal{N}(0, \sigma^2)) \quad (27)$$

where  $\mathcal{N}(0, \sigma^2)$  represents a Gaussian distribution with standard deviation  $\sigma$  and zero expectation. The standard deviation is strongly related with the mean rate mutation. For bipolarized binary alphabet the standard deviation will represent a mean rate mutation as shown in Figure 3.

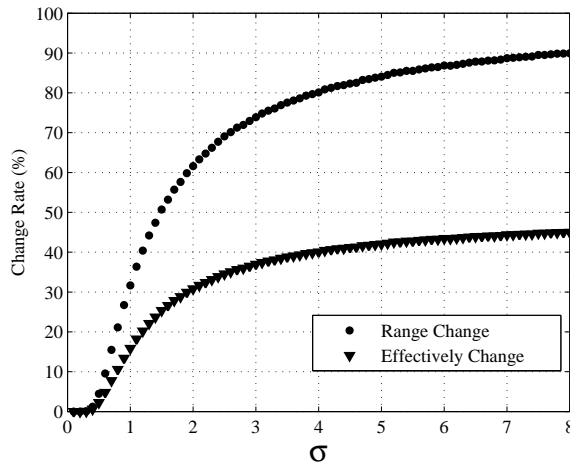

**Figure 3:** Bit change rate as a function of standard deviation.

This figure presents the average and maximum rate of mutation in relation to the standard deviation. For each algorithm a standard deviation was chosen that corresponded to a rate of adjusted average mutation. It is clear that the mutation can occur in one or more points of the individual, or also none, due to the stochastic nature of the process.

### 3.6 Replacement Strategy

Replacement strategies look for to establish a biological rule of composition of individuals being aimed at the next generation, determining the maximum number of individuals supported in the physical space in real systems. In terms of mathematical description, replacement strategy corresponds to the determination of the number of candidate vectors to be kept in the next generation.

The elitism strategy forces the evolutionary algorithms to retain some number of the best individuals at each generation. Such individuals can be lost if they are not selected to reproduce or if crossover or mutation destroys them. In this strategy successive generations overlap to some degree, i.e., some portion of the previous generation is retained in the new population [Mitchell, 1998]. This work uses replacement strategy called global elitism, where only the best  $p$  individuals from the joint population of parents and offsprings are maintained for the next generation.

### 3.7 Termination Criteria

Basically three forms can be identified as termination criteria for evolutionary algorithms. The most adequate termination criteria depends on the nature of the problem. The search can be stopped after a fixed number of generations or after it reaches a threshold or after a pre-fixed time interval. The most common criterion found in the literature, for the MuD problem, is to stop the optimization process after a fixed number of generations ( $G$ ).

### 3.8 Convergence Generation Determination

A criterion for convergence generation determination of evolutionary algorithms consists in to analyze carefully the absence of evolution in successive generations by comparing the fitness value. When:

$$\Omega_g(\mathcal{B}_1) = \Omega_{g+1}(\mathcal{B}_1) = \dots = \Omega_G(\mathcal{B}_1) \quad (28)$$

with  $\mathcal{B}_1$  representing the best candidate in that generation,  $g$  will indicate the convergence generation of the algorithm. Another criterion considers the convergence generation is that one that presents no significant gain based on the fitness value when compared with previous generations. In this work was adopted the more conservative criterion, equation (28).

Finally, the GA-MuD and EP-MuD algorithms are described in Table 1.

## 4 Numerical Results

In this section the performance of the algorithms, described in section 3, are compared considering the BER as the main figure of merit. The convergence

of each algorithm is also considered. For the asynchronous DS/CDMA MuD problem, over Rayleigh fading channels, the numerical results were obtained based on the Monte Carlo simulation method; these results were obtained in identical systems and channel conditions in order to be fair with the algorithms comparison. Finally the GA-MuD and EP-MuD algorithms are analyzed in terms of computational complexity, conducting to the construction of an effective figure of merit.

GA-MuD	EP-MuD
<b>Input:</b> $p, \mathcal{B}_1, T, G$ <b>Output:</b> $\mathcal{B}_1$ begin 1. Initialize first population $\mathcal{B}; g = 0$ ; 2. Evaluate the fitness( $\mathcal{B}$ ); 3. while $g < G$ then; 4. $\mathcal{B}_{selected} = \text{Selection}(\mathcal{B}, T)$ ; 5. $\mathcal{B}_{cross} = \text{Crossover}(\mathcal{B}_{selected})$ ; 6. $\mathcal{B}_{new} = \text{Mutation}(\mathcal{B}_{cross})$ ; 7.   Evaluate the fitness( $\mathcal{B}_{new}$ ); 8. $\mathcal{B} = \text{Replacement}(\mathcal{B} \cup \mathcal{B}_{new})$ ; 9. end end	<b>Input:</b> $p, \mathcal{B}_1, T, G$ <b>Output:</b> $\mathcal{B}_1$ begin 1. Initialize first population $\mathcal{B}; g = 0$ ; 2. Evaluate the fitness( $\mathcal{B}$ ); 3. while $g < G$ then; 4. $\mathcal{B}_{selected} = \text{Selection}(\mathcal{B}, T)$ ; 5. $\mathcal{B}_{new} = \text{Mutation}(\mathcal{B}_{selected})$ ; 6.   Evaluate the fitness( $\mathcal{B}_{new}$ ); 7. $\mathcal{B} = \text{Replacement}(\mathcal{B} \cup \mathcal{B}_{new})$ ; 8. end end

**Table 1:** GA-MuD and EP-MuD algorithms

Table 2 synthesizes the main parameters for the simulated system: the spread sequences are selected as pseudo-noise (PN); the number of active asynchronous users in the system is  $K$ ; the processing gain is  $N$ , the system loading is  $U = K/N$ ; 10 and 20 users were considered for the DS/CDMA system over single-path (Flat), two-paths and three-paths (selective) slow Rayleigh channels. For the performance determination with mobility,  $K$  users were considered with a velocity uniformly distributed in the interval  $[0; v_{max}]$ , resulting in a maximum Doppler frequency of  $f_m = \frac{v_{max}}{\lambda_c} = 222.2 \text{ Hz}$ , for a carrier frequency of  $f_c = \frac{1}{\lambda_c} = 2 \text{ GHz}$ ; the maximal Rake diversity is  $D = 3$  and all users are transmitting with the same data rate,  $R_b$ .

Seqs	$N$	$K$	$U$	Channel	$R_b$	$v_{max}$	$f_m$	$D$
PN	31	10; 20	0.32; 0.64	slow Rayl	384 kb/s	120 km/h	222 Hz	$\leq 3$

**Table 2:** Main System Parameters

Table 3 shows three exponential power-delay profiles that were adopted for the performance analysis: three paths (PD-1), two paths (PD-2) and a Flat (PD-

3) Rayleigh channels. These profiles with reduced number of multipaths were adopted in order to alleviate the simulation's complexity and the processing time. In order to accommodate  $L = 3$  paths for all  $K = 10$  users in the same  $[0; N]T_c$  time interval, a minimum number of samples by chip was fixed as  $N_s = 2$ , and also for the case  $K = 20$  and  $L = 2$ .

Another more realistic profile adopted in simulations relaxes the restriction of paths time separation of Table 3. In this worst case scenario, despite that the adopted inter-users delays are crescent in the interval  $[0; (N-1)T_c - \Delta_{\ell_{max}}]$ , paths overlapping from the same user is allowed ( $\Delta_{k,\ell} - \Delta_{k,\mathcal{L}} < T_c$ ) or still between the last path of  $k$ -th user with the first path of  $(k+1)$ -th user, resulting, in the first situation, in Rake diversity reduction,  $D < L$ , simulating non-discernable paths in the receiver. Simulation results of this section show that the performance is degraded in this situation.

$\ell$	$\Delta_\ell$	$E[\beta_\ell^2]$	$\ell$	$\Delta_\ell$	$E[\beta_\ell^2]$	$\ell$	$\Delta_\ell$	$E[\beta_\ell^2]$
1	0	0.8047	1	0	0.8320	1	0	1
2	$T_c$	0.1625	2	$T_c$	0.1680	PD-3		
3	$2T_c$	0.0328	PD-2			PD-1		

**Table 3:** Tree power delay profile (PD) used in the simulations.

In all simulations it was assumed that the powers, phases, amplitudes, channel gains and random delays of all users are perfectly known in the receiver, except at the end of this section, where the errors impact of channel coefficient estimates are analyzed. For the channel coefficients generation a modified Gans model was adopted [Silva et al., 2004], with coefficients generated in the frequency domain. Further, a perfect power control scenario ( $P'_1 = P'_2 = \dots = P'_K$ ) was assumed, as well as unbalanced received power scenarios with half of user with  $NFR \in [-5; +15]$ dB for  $K = 10$  users, and  $NFR \in [-5; +25]$ dB for  $K = 20$  users.

In all Monte Carlo simulations a minimum number of errors/point = 15 was adopted for the region with high  $E_b/N_0$  and 100 errors/point for regions with low and medium  $E_b/N_0$ . The average  $E_b/N_0$  at the receiver input is given by  $\bar{\gamma} = \sum_{\ell=1}^L \bar{\gamma}_\ell$ , where  $\bar{\gamma}_\ell = \frac{E_b}{N_0} E[\beta_\ell^2]$ . For comparison purpose the performances of the Rake receiver and the single user bound (a system without MAI) were included. This analytical single user bound (SuB) for BER, considering BPSK modulation, Rayleigh channel, a Rake receiver with MRC with diversity  $D = L$ , and all paths with distinct mean-square values is given by [Proakis, 1989]:

$$BER_{Bound} = \frac{1}{2} \sum_{\ell=1}^D \left\{ \left[ 1 - \sqrt{\frac{\bar{\gamma}_\ell}{\bar{\gamma}_\ell + 1}} \right] \prod_{i, i \neq \ell}^D \frac{\bar{\gamma}_\ell}{\bar{\gamma}_\ell + \bar{\gamma}_i} \right\} \quad (29)$$



The adopted parameters values for the heuristic algorithms were obtained in two steps: preliminary simulations with typical values found in the literature; additional simulations in order to optimize these parameters, not in an exhaustive form, however assuring a superior performance than those found in the preliminary step. Table 4 synthesizes the main parameters used in the simulations. These parameters are grouped in function of loading resulting in two systems,  $\mathbf{S}_1$  and  $\mathbf{S}_2$ . In all simulations the evolutionary receivers process and optimize one frame with  $K.I.D$  bits each time, where  $K = 10$  or  $20$  users,  $I = 7$  bits/user,  $D = 1$  or  $2$  or  $3$  paths/user, for the same channel conditions, transmission and initial estimates from the Rake receiver output.

Algorithm	$p$	$p_m$	$p_c$	$T$	$G$	$p$	$p_m$	$p_c$	$T$	$G$
<b>GA-MuD</b>	110	1.43%	50%	11	40	150	0.71%	50%	15	60
<b>EP-MuD</b>	110	5%	—	11	40	150	5%	—	15	60
	$K = 10$ users, $I = 7$ bits					$K = 20$ users, $I = 7$ bits				
	<b>S<sub>1</sub></b>					<b>S<sub>2</sub></b>				

**Table 4:** Main Algorithms Parameters.

The selection process adopted for the GA-MuD algorithm was the  $p$ -Sort selection; from the simulation results, synthesized in Figure 4, this selection mode has better convergence performance than the Roulette Wheel. Thereby, for all simulations of the GA-MuD and EP-MuD algorithms the  $p$ -Sort selection was adopted. For the crossover operator the uniform type was adopted with the crossover mask generated randomly (50%). For the mutation operator a Gaussian distribution was adopted with  $\mathcal{N}(0, \sigma_m^2)$ , where  $\sigma_m^2$  is analytically obtained from the mutation probability shown in Figure 3. The replacement strategy adopted in the two algorithms is the Global Elitism. The population  $p$  was chosen from the population size analysis, equation (25). For the GA-MuD algorithm the mutation percentage was adopted as  $p_m = \frac{100}{K.I}$ , i.e., one mutation (one bit) by individual, in average, which is a normal value found in the literature for this algorithm. Looking for the algorithms convergence, the adopted number of generations was increased from  $G = 40$  to  $G = 60$  when the loading was increased from  $U \approx 0.32$  to  $U \approx 0.64$ .

Figure 4 show that the evolutionary algorithms EP-MuD and GA-MuD  $p$ -Sort converge to the SuB performance after  $g \approx 22$  and  $17$  generations, respectively, resulting in a huge performance gain in contrast to the conventional receiver. For this type of channel, with low load  $U \approx 0.32$  and perfect power control, the GA-MuD algorithm shows better convergence than the EP-MuD algorithm because it uses the crossover and mutation strategies as its diversification principle.

Figures 5 to 11 show the performance as a function of signal to noise ratio

( $\bar{\gamma}$ ) or  $NFR$  as well as the generation where the convergence occurs,  $g$ , given by equation (28), for the two algorithms in each performance point. In general, for all of analyzed conditions and channels, the GA-MuD algorithm converges to the SuB performance with a smaller  $g$  than the EP-MuD algorithm. The slower convergence of EP-MuD algorithm is mainly due to its less efficient diversification strategy and the absence of any intensification strategy. Note that not necessarily greater convergence velocity results in smaller computational complexity. The analysis presented in section 5 quantifies the additional complexity in the crossover stage for the GA-MuD algorithm.

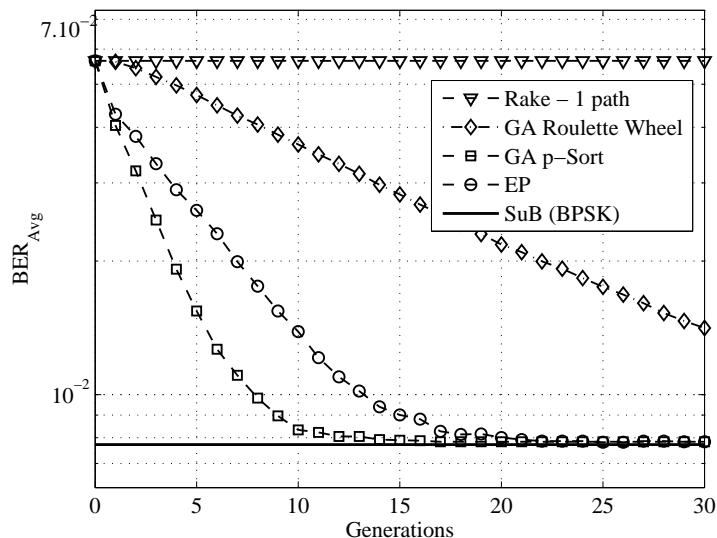

Figure 4: Convergence velocity for EP-MuD and GA-MuD; two selection strategies for the GA-MuD ( $p$ -Sort and Roulette Wheel); System  $S_1$ ; PD-3 profile;  $\bar{\gamma}_1 = 15 \text{ dB}$  and  $NFR = 0 \text{ dB}$ .

Figure 5 synthesizes the excellent performance obtained with the GA-MuD and EP-MuD algorithms for low loads and soft channel conditions. In this situation the algorithms need a small number of generations for medium and high  $\bar{\gamma}$  values, showing also the floor noise effects on the convergence velocity for small values of  $\bar{\gamma}$ .

The general behavior for the algorithms with 2 and 3 paths Rayleigh channel, PD-2 and PD-3 profiles, respectively, is shown in Figures 6 and 7. Note that the Rake diversity helps to maintain the excellent performance of evolutionary algorithms when it has the total exploitation of diversity,  $D = L$ , resulting in a smaller  $g$  than the single path case. Even not reaching the total convergence for some points with low  $\bar{\gamma}$ , as defined by equation (28), the performance obtained for the GA-MuD and EP-MuD algorithms is very close to the SuB case. For

the sake of comparison, Figure 6 includes the performance result of the classic decorrelator for frequency selective fading channel [Zvonar and Brady, 1996]. In this case, the decorrelating matrix ( $\mathbf{R}^{-1}$ ) has dimension  $K.I.D \times K.I.D$ . When the number of users, processed frame length or multipath diversity increases, the inverse matrix calculation becomes impracticable. Further, we can verify from the Figure 6 that the decorrelator performance is inferior to the found with the evolutionary algorithms.

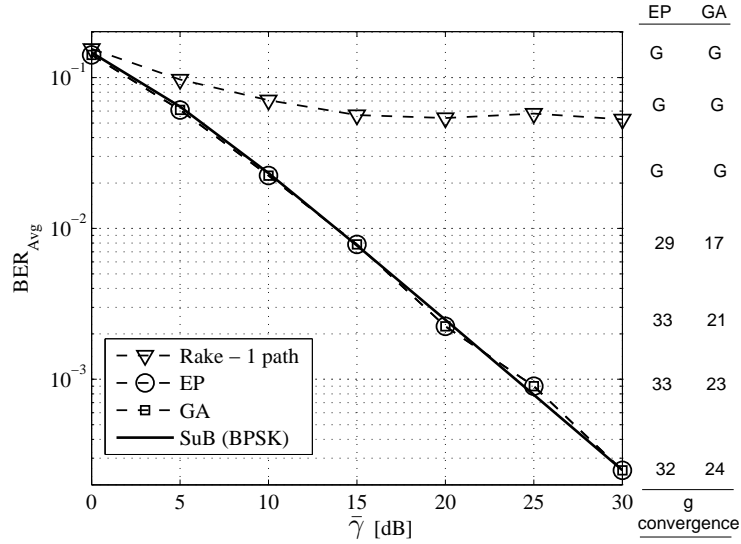

Figure 5: BER of system  $\mathbf{S}_1$ , PD-3 profile and  $NFR = 0$  dB.

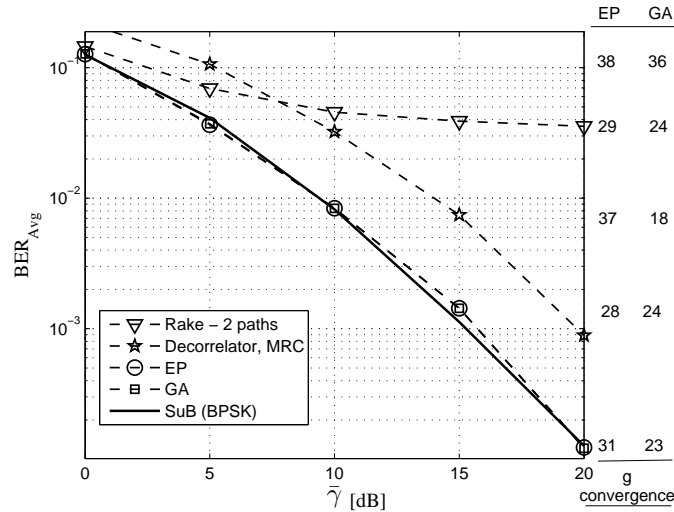
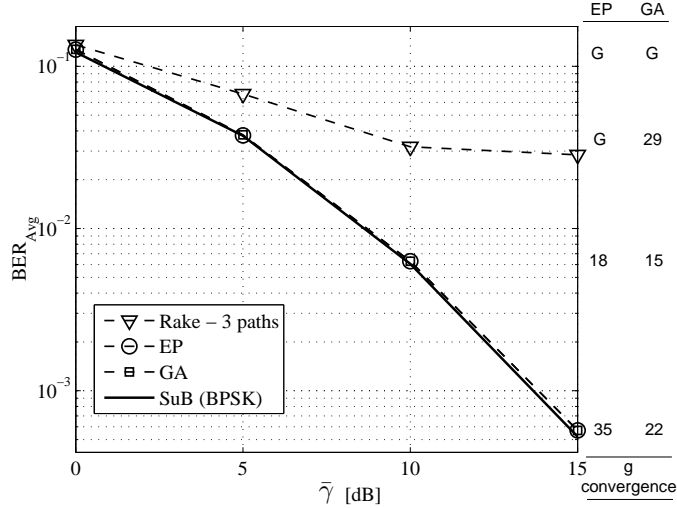

Figure 6: BER for the system  $\mathbf{S}_1$ ,  $NFR = 0$  dB, PD-2 profile and  $D = L = 2$ .

However in more realistic selective channel scenarios, when occasionally some paths from the same user can overlap, meaning loss of Rake diversity (non-discernible paths,  $D < L$ ), the performance degrades with conventional receivers. Despite this unfavorable scenario the two evolutionary receivers reach a performance that is better than the obtained with the Rake receiver, as indicated in Figures 8 and 9. In these cases the performance is confined between the SuB limits for  $D = L$  and  $D = 1$ , because occasionally will occur some non-discernible paths.



**Figure 7:** BER for the system  $S_1$ ,  $NFR = 0$  dB, PD-1 profile and  $D = L = 3$ .

The performance illustrated in Figure 8 indicates that the performance of GA-MuD and EP-MuD receivers converge to a limit where there is no way to take advantage of the total Rake diversity. This performance limit reaches an intermediate value between the performance in the absence of diversity ( $D = 1$ ) and the performance with maximal diversity ( $D = L$ ), tending to the worst case when the number of non-discernible paths increases. The same effect is present in the performance shown in Figure 9 for the system  $S_2$ . However, due to the joint effects of high loading and non-discernible paths, the performance degrades when confronted with the low loading case. A possible association of the BER floor effect to the GA-MuD and EP-MuD algorithms performance should be discarded, because the number of generations used in this condition was insufficient in order to reach the convergence. Thus, with  $G > 60$  the GA-MuD and EP-MuD algorithms, for  $\bar{\gamma} = 15$  dB, will have the same performance behavior of Figure 8.

Even for high load in multipath channels the GA-MuD and EP-MuD detection algorithms keep a high performance gain in comparison with the Rake receiver. Figure 10 synthesizes the performance gain for a channel with PD-2

profile. The performances are very close to the SuB case, though the number of generations has been insufficient.

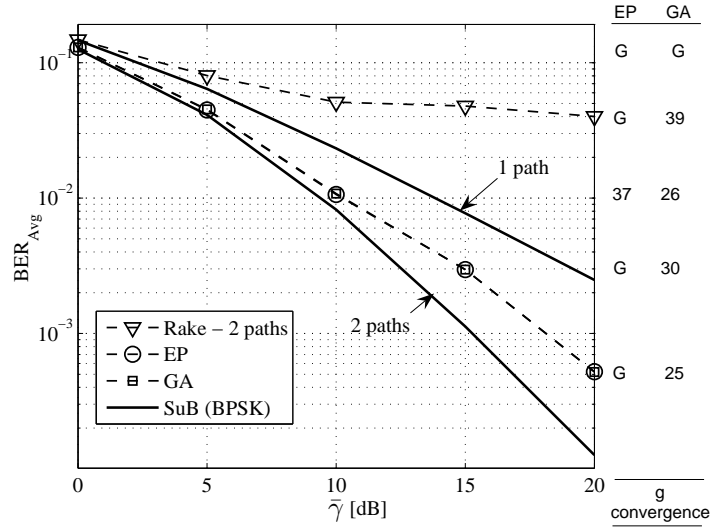

Figure 8: BER for the system  $\mathbf{S}_1$ ,  $NFR = 0\text{ dB}$ , PD-2 profile with  $D < L = 2$  occasionally.

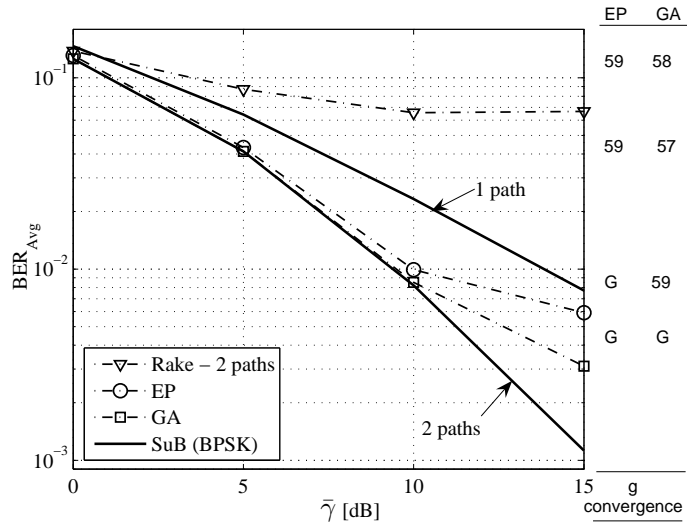

Figure 9: BER for the system  $\mathbf{S}_2$ ,  $NFR = 0\text{ dB}$ , PD-2 profile with  $D < L = 2$  occasionally.

In CDMA systems the  $NFR$  parameter expresses the power disparities among users. Conventional CDMA systems are limited by interference; in this way, they need complex and elaborated power control mechanisms in order to reach their

theoretical capacity. Receivers that are able to recover the user information despite the adverse conditions imposed by power disparities can help for the systems implementation complexity reduction.

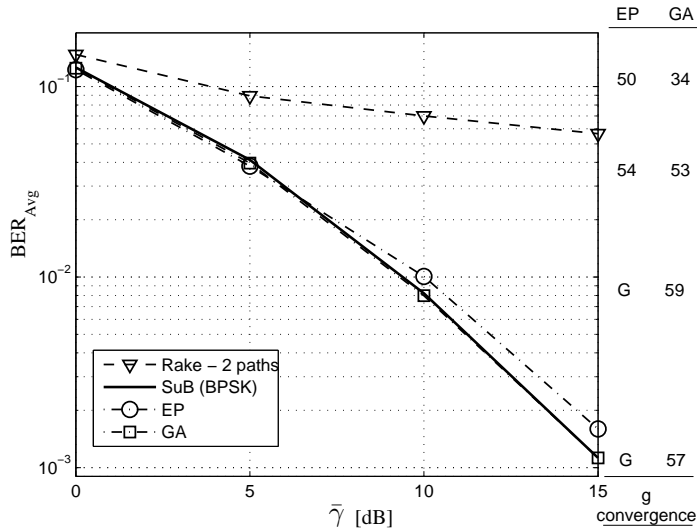

Figure 10: BER for the system  $\mathbf{S}_2$ ,  $NFR = 0$  dB, PD-2 profile and  $D = L = 2$ .

In Figures 11.a and 11.b, the power ratio, on the  $NFR$ -axis, is the ratio of the received power of the interfering users ( $P'_1 = P'_2 = \dots = P'_{\frac{K}{2}}$ ) to the power of desired users ( $P'_{\frac{K}{2}+1} = \dots = P'_{K-1} = P'_K$ ). These results show that the GA-MuD and EP-MuD algorithms have a high robustness to the near-far effect, in spite of the number of generations for the EP-MuD algorithm has been insufficient in order to reach the total convergence in the high load condition for the system  $\mathbf{S}_2$ . On the other hand the Rake receiver performance is drastically reduced with the power increase of interfering users, even with low loads for the system  $\mathbf{S}_1$ .

The performance degradation of the GA-MuD [Ciriaco and Jeszensky, 2005] and EP-MuD algorithms was also analyzed considering errors in the channel estimates (module and phase). The performance results (not shown here) indicated that even with great errors in the module and phase estimates, about up to 15%, the GA-MuD and EP-MuD algorithms reach better performances than those obtained with the Rake detector in the absence of errors, evidencing the enormous tolerance of these algorithms to errors in the channel estimates. The two algorithms are equally more sensitive to phase than module errors.

## 5 Computational Complexity

A common form in order to compare algorithms complexity can be done through the  $\mathcal{O}$  notation, which means the order of magnitude of the algorithm complexity.

But comparing algorithms only with  $\mathcal{O}$  can be insufficient, mainly when they are similar or have the same order of magnitude. This work presents the algorithms complexity using three figures of merit: the  $\mathcal{O}$  notation, the number of computed instructions and the comparison of the mean computational time required for a specific optimization.

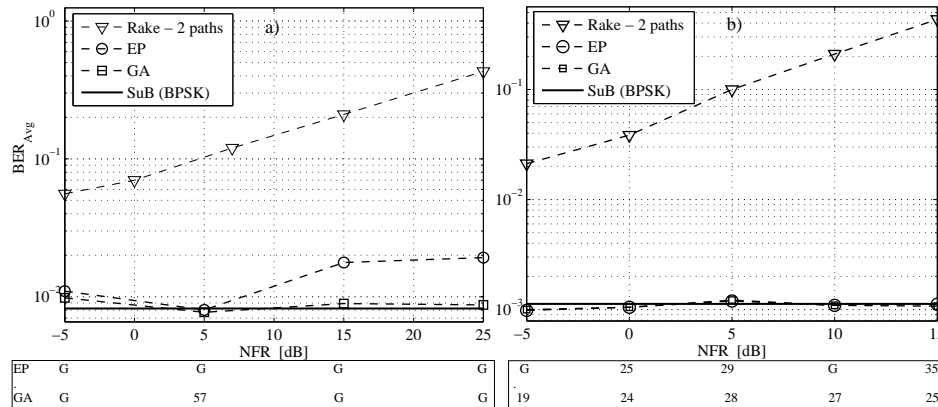

Figure 11: BER for the system: a)  $\mathbf{S}_1$  with half of users with  $\bar{\gamma} = 15$  dB and the remainder with  $NFR \in [-5, +15]$ ; b)  $\mathbf{S}_2$  with half of users with  $\bar{\gamma} = 10$  dB and the remainder with  $NFR \in [-5, +25]$ ; both systems with PD-2 profile and  $D = L = 2$ .

In order to obtain the number of instructions computed by each algorithm, the float point operations measurement concept was used [Higham, 1996]. This measure considers as one instruction all those operations, done by a processor, which show a relevant computational time, named here as main operations. In this work the multiplication and division were considered as main operations and addition and subtraction were neglected because their computational times are irrelevant when compared with the formers.

In the MuD problem other main operations carried out by the algorithms are: ordination, transposition, comparison, change, generation and selection. These operations have a complexity proportional to operation order, vector's size or the number of elements in a matrix.

In order to express the complexity of the analyzed algorithms it is necessary to determine which instructions are carried out and how many times they are processed. For the fitness value calculation, equation (18), the set of operations  $\mathcal{F}_1 = \mathcal{C}^H \mathcal{A} \mathcal{Y}$  and  $\mathcal{F}_2 = \mathcal{C} \mathbf{A} \mathbf{R} \mathcal{A} \mathcal{C}^H$  can be obtained before the optimization loop of each algorithm. For each test of a candidate solution  $\mathcal{F}_1 \mathcal{B}$  and  $\mathcal{B}^T \mathcal{F}_2 \mathcal{B}$  are computed, which in terms of operations is equivalent to  $(K.I.D)^2 + 2K.I.D$  multiplications and one transposition of order  $K.I.D$ . For the OMuD the number of operations increases exponentially with the number of users, i.e.,  $\mathcal{O}(2^{K.I}(K.I.D)^2)$ .

For a system in a fading channel,  $2^{K \cdot I}$  bit generations of order  $K \cdot I \cdot D$  and  $2^{K \cdot I}$  calculations for the fitness value are necessary, for the simultaneous detection of one frame with  $I$  bits for each of the  $K$  users. For an AWGN channel the coefficients matrix is reduced to  $\mathcal{C} = \mathbf{I}$ ; for synchronous channel the correlation matrix dimension is reduced to  $K \times K$ .

For the EP-MuD algorithm the number of operations increases depending of the relation  $\mathcal{O}(p \cdot g \cdot (K \cdot I \cdot D)^2)$ ,  $2p \cdot g + p - 1$  bit generations of order  $K \cdot I \cdot D$ ,  $T \cdot g$  selections of order  $K \cdot I \cdot D$ ,  $p \cdot g + p$  calculations of the fitness value and  $3p \cdot g$  ordinations of order  $K \cdot I \cdot D$  are necessary. The GA-MuD algorithm computational complexity also increases depending of the relation  $\mathcal{O}(p \cdot g \cdot (K \cdot I \cdot D)^2)$ , and can be obtained adding the crossover operator complexity to the EP-MuD algorithm complexity. This stage performs  $p \cdot g$  generations of order  $K \cdot I \cdot D$ ,  $p \cdot g$  comparisons of order  $K \cdot I \cdot D$  and  $p \cdot g$  changes of bits of order  $K \cdot I \cdot D$ .

Considering that each instruction  $\mathbf{x}$  will own a proper associated time  $\mathbf{t}(\mathbf{x})$ , a program **Prog**, with a constant input, will process  $\mathbf{r}_1$  times instructions of type  $\mathbf{x}_1$ ,  $\mathbf{r}_2$  times instructions of type  $\mathbf{x}_2$ , until  $\mathbf{r}_m$  times instructions of type  $\mathbf{x}_m$ . In this case the execution time for the program **Prog** will be given by:

$$\text{Time}(\text{Prog}) = \sum_{j=1}^m \mathbf{r}_j \mathbf{t}(\mathbf{x}_j) \quad (30)$$

In last analysis the study of the algorithm complexity could be solved through the evaluation of (30). In order to simplify the computational time evaluation for each instruction  $\mathbf{x}_j, j = 1, \dots, m$ , consider  $\mathbf{t}(\mathbf{x}) = 1$  for any instruction  $\mathbf{x}$ . This simplification is coherent with the use of  $\mathcal{O}$  notation for computational analysis, once the instructions duration ratios are obviously constant, which would be irrelevant for the calculation of order of magnitude of complexity. Another advantage in to adopt  $\mathbf{t}(\mathbf{x}) = 1$  is that in this way the value of the execution time of a program is equaled with the total number of computed instructions, being respected the order of each instruction.

$$\text{Instructions}(\text{Prog}) = \sum_{j=1}^m \mathbf{r}_j \quad (31)$$

Therefore the computational complexity of the EP-MuD, GA-MuD and Optimum MuD receivers can be expressed, in terms of executed instructions, adding the number of operations of each fitness value with all other operations multiplied by its orders, as indicated in Table 5.

Using numerical values from simulations for the variables  $g, K, I, D, T$  and  $p$  is possible to express the computational complexity of each algorithm in terms of the number of operations in order to reach the convergence. These numbers for various simulated conditions are synthesized in Figures 12 and 13. Given the excessive number of necessary operations for the OMuD the respective results are indicated in Table 6.



Detector	Number of Operations
OMuD	$2^{KI} \left( (KID)^2 + 3KID \right)$
GA-MuD	$p(g+1)(KID)^2 + (g(11p+T) + 4p-1)(KID)$
EP-MuD	$p(g+1)(KID)^2 + (g(8p+T) + 4p-1)(KID)$

**Table 5:** MuD complexity in terms of operations

Complexity	$PD-3$	$PD-2$	$PD-1$	$PD-2$
<b>OMuD</b>	$\approx 6 \times 10^{24}$	$\approx 2 \times 10^{25}$	$\approx 5 \times 10^{25}$	$\approx 1 \times 10^{47}$
	<b>S<sub>1</sub></b>			<b>S<sub>2</sub></b>

**Table 6:** Number of operations for the OMuD

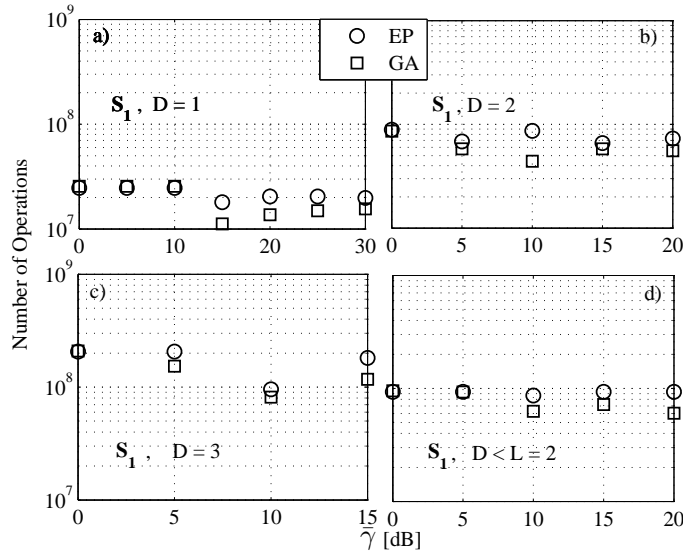

Figure 12: Number of executed operations for the system  $\mathbf{S}_1$  in channels: a) PD-3 profile (Flat); b) PD-2 profile (2 paths); c) PD-1 profile (3 paths) and d) PD-2 profile with  $D \leq L$ .

For the OMuD increasing the loading from the system  $\mathbf{S}_1$  to  $\mathbf{S}_2$  caused an increase in the number of operations of 22 times in terms of order of magnitude, making impracticable its implementation in a real scenario. Thus, in this case, simulation results could not be obtained. On the other hand, the complexity (in terms of number of operations) of the analyzed evolutionary receivers show orders of magnitude of  $10^8$  for the system  $\mathbf{S}_1$  and  $10^9$  for  $\mathbf{S}_2$  (no shown here), indicating a huge complexity reduction in comparison with the OMuD. Addi-

tionally, increasing the load from  $U \approx 0.32$  to  $U \approx 0.64$  caused, approximately only one order of magnitude increase for the complexity of algorithms GA-MuD and EP-MuD.

For the same system conditions, comparing the executed number of operations by the two evolutionary receivers, the difference has an order of magnitude smaller than 1/2, even when the system load and  $NFR$  conditions increases.

When the channel selectivity and the receivers bandwidth allow an increase in the number of processing paths for the EP-MuD and GA-MuD algorithms, for example from  $D = 1$  to 2 or 3, the systems will have a better performance without a significant increase in the complexity. Figure 5 shows that for  $D = 1$  and  $\bar{\gamma} = 15$  dB the performance is  $\approx 8 \times 10^{-3}$ , while from Figure 7, for  $D = 3$ , and the same value of  $\bar{\gamma}$  the performance is  $\approx 5.5 \times 10^{-4}$ . In order to reach this performance, the order of magnitude of complexity have increased by only one order, Figures 12.a and 12.c, justifying the exploration of larger diversities in evolutionary receivers.

Figure 13 shows that the computational cost for maintaining the near-far robustness is almost constant for the EP-MuD and GA-MuD algorithms, because the number of needed operations is of order  $10^8$  for the system  $\mathbf{S}_1$  and  $10^9$  for the system  $\mathbf{S}_2$ , being practically constant in all range of simulated power disparities and also identical to the perfect power control scenario ( $NFR = 0$ ).

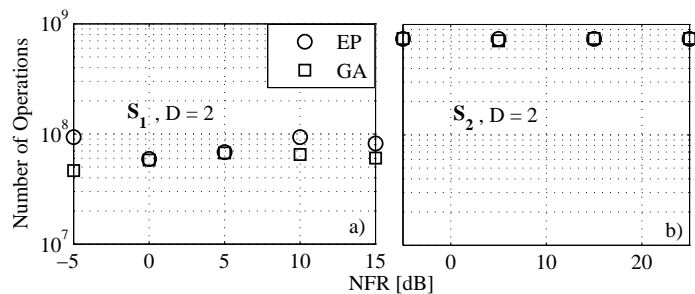

Figure 13: Number of executed operations *versus*  $NFR$  in PD-2 profile channels and system: a)  $\mathbf{S}_1$  with  $\bar{\gamma} = 15$ dB; b)  $\mathbf{S}_2$  with  $\bar{\gamma} = 10$ dB.

Finally, the computational complexity of the algorithms can be also measured through the computational time spent by each algorithm in order to conclude one optimization. A model described in [Fitzpatrick and Grefenstette, 1988], establishes the computational time required by the evolutionary algorithms in order to conclude one optimization and indicates that the necessary time depends on the parameters  $g$  and  $p$  and the time constants involved in the processes described in section 3:

$$Time(\text{Prog}) = \sum_{j=1}^m r_j t(x_j) = (\mu \cdot p + \psi \cdot p) \cdot g \quad (32)$$

where  $g$  is the number of generations for convergence and  $p$  is the population

size given by equation (25). The variable  $\mu$  represents the fixed amount of evolutionary algorithms overhead time per individual per generation, which includes the costs of all process described in section 3, but excludes the cost of fitness evaluations. The variable  $\psi$  represents the cost of a single fitness evaluation of one individual. This model does ignore the cost of population initialization, but this is reasonable as the runtime costs dominate.

In order to find the constants  $\mu.p$  and  $\psi.p$ , the average time required by each fitness value evaluation and the average execution time of other processes of algorithms were measured, for some values of  $K.I.D$ . These time averages<sup>2</sup> are presented in Figure 14.

Note that the values of the constants  $\mu$  and  $\psi$  depend on the size of individual, in this application,  $K.I.D$ . Already the population size is proportional only to the factor  $K.I$ . Through these data the average execution time for each optimization can be expressed. The same conclusions obtained with the complexity analysis in terms of number of operations are now applicable to the analysis of the computational time of Figures 15 to 16. Again, given the excessive number of operations for the OMuD the respective results are indicated in Table 7.

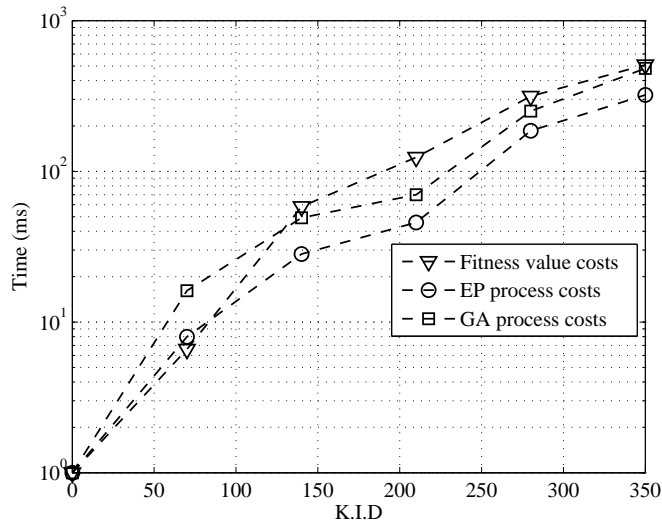

Figure 14: Average computational time (over 1000 trials) for the fitness value and the processes of evolutionary algorithms, in milliseconds.

The GA-MuD algorithm needs a lightly smaller computational time than the EP-MuD in the same simulated conditions and with total convergence for both. This can be verified, for example, through Figure 15.b combined with the convergence information of Figure 6, among others.

<sup>2</sup> Results obtained with MatLab 7.0 platform for Windows XP in a Athlon 1.6GHz processor with 512Mb RAM

Complexity	$PD - 3$	$PD - 2$	$PD - 1$	$PD - 2$
<b>OMuD</b>	$\approx 7.8 \times 10^{21}$	$\approx 6.9 \times 10^{22}$	$\approx 1.5 \times 10^{23}$	$\approx 4.4 \times 10^{44}$
	<b>S<sub>1</sub></b>			<b>S<sub>2</sub></b>

**Table 7:** Average Computational Time for OMuD detector in [ms]

Again, when total convergence do not occur in  $G$  generations for both algorithms, the EP-MuD intrinsically will have a smaller complexity considering the computational time and a smaller number of operations than the GA-MuD algorithm because the EP-MuD algorithm has a more simple search strategy. If the number of generations are increased, assuring total convergence for both algorithms in terms of equation (28) the EP-MuD algorithm complexity will be greater than the GA-MuD in terms of the number of operations and also computational time.

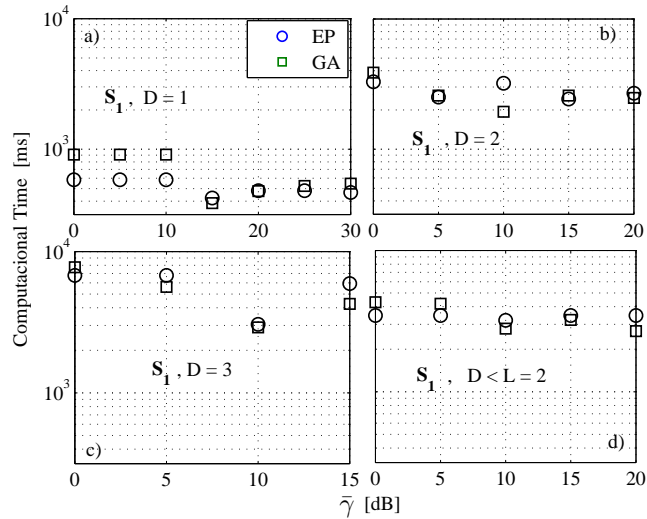

Figure 15: Computational time for the system  $\mathbf{S}_1$  in channels: a) PD-3 profile (Flat); b) PD-2 profile (2 paths); c) PD-1 profile (3 paths); and d) PD-2 profile with  $D \leq L$ .

Since the optimum values for the parameters  $p_m$  and  $T$  depend on the DS/CDMA system characteristics, i.e., diversity, loading, signal to noise ratio and  $NFR$  effects, it must be expected a reduction in the convergence generation for both algorithms when these optimized parameters will be used. It should be noted that the values of these parameters are fixed and only altered as a function of loading, for the results of this section. Observe that for  $D = 1$ ,  $\bar{\gamma} \leq 10$  dB and low loading, Figure 15.a, the GA-MuD algorithm parameters are not optimized, implying in a greater computational time than the EP-MuD algorithm in

the same conditions. Therefore, an additional parameters optimization analysis should be carried out.

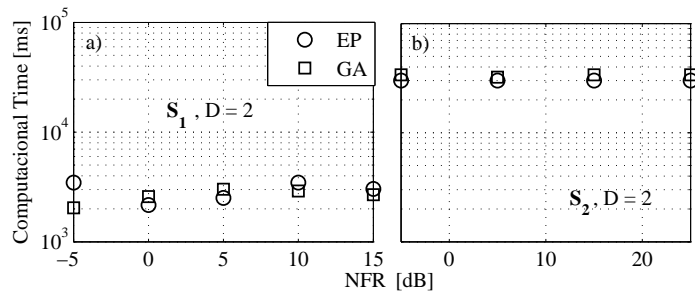

Figure 16: Computational time  $\times NFR$  in channels PD-2 profile and systems: a)  $S_1$  with  $\bar{\gamma} = 15$  dB; b)  $S_2$  with  $\bar{\gamma} = 10$ dB.

## 6 Summary

In this work two optimization techniques were analyzed: the GA-MuD and EP-MuD evolutionary algorithms. These techniques were directly applied to the optimum detection problem in DS/CDMA communications trying to increase the system's capacity. It should be highlighted that very few works deal with the evolutionary algorithms for MuD in multipath Rayleigh channels. This work established an efficient comparison, in terms of complexity *versus* performance, among multiuser detectors based on the EP-MuD and GA-MuD algorithms in realistic channels; the performance reduction due to diversity reduction was also evaluated.

The algorithms comparison through the computational time and the number of executed instructions has showed to be more adequate than the comparison using the  $\mathcal{O}$  notation, because the two analyzed algorithms have similar order of magnitude of complexity. Therefore, using these two figures of merit it is possible to compare more precisely the efficiency of the EP-MuD and GA-MuD algorithms when applied to the MuD problem. The result of the convergence analysis using these two figures of merit for the complexity shows a small superiority for the GA-MuD algorithm in confront with the EP-MuD algorithm for the analyzed conditions of loading,  $NFR$  and when there are losses in the utilization of multipath diversity.

The EP-MuD and GA-MuD multiuser detectors in Rayleigh fading channels, flat and multipath, approaches the SuB limit in all analyzed conditions with the advantage of a huge complexity reduction in comparison with the OMuD, making feasible its implementation in base stations of cellular systems.

Both algorithms have a relative immunity against channel coefficient errors and great robustness against  $NFR$  effects in low and high load conditions, despite

that the EP-MuD algorithm not to have converged with  $G = 60$  interactions in the high load condition.

Future works include the performance analysis in a scenario with estimation errors for the main DS/CDMA parameters, such as delays, powers and so on. Finally, as noted before, the set of the EP-MuD and GA-MuD parameters employed in this work is by no means optimum and further research will concentrate on how to find other algorithms capable of adjusting these parameters.

## References

- [Abedi and Tafazolli, 2001] Abedi, S. and Tafazolli, R. (2001). Genetically modified multiuser detection for code division multiple access systems. *IEEE Journal on Selected Areas in Communications*, 20(2):463–473.
- [Abrão et al., 2004] Abrão, T., Ciriaco, F., and Jeszensky, P. J. E. (2004). Evolutionary programming with cloning and adaptive cost function applied to multi-user ds-cdma systems. In *IEEE International Symposium on Spread Spectrum Techniques and Applications (ISSSTA 04)*, pages 160–164, Sydney, Australia.
- [Ahn and Ramakrishna, 2002] Ahn, C. W. and Ramakrishna, R. S. (2002). A genetic algorithm for shortest path routing problem and the sizing of populations. *IEEE Transactions on Evolutionary Computation*, 6(6):566–578.
- [Ciriaco and Jeszensky, 2005] Ciriaco, F., A. T. and Jeszensky, P. J. E. (2005). Genetic algorithm multiuser detection in fading channel with parameters errors estimates. In *International Microwave & Optoelectronics Conference, IMOC'05*, Brasília, Brazil.
- [Duel-Hallen, 1995] Duel-Hallen, A. (1995). A family of multiuser decision-feedback detectors for asynchronous cdma channels. *IEEE Transactions on Communications*, 43(2/3/4):421–434.
- [Fitzpatrick and Grefenstette, 1988] Fitzpatrick, J. M. and Grefenstette, J. J. (1988). Genetic algorithms in noisy environments. *Machine Learning*, (3):101–120.
- [Fogel, 1994] Fogel, D. B. (1994). An introduction to simulated evolutionary optimization. *IEEE Transactions on Neural Networks*, 5:3–13.
- [Harik et al., 1999] Harik, G., Cantú-Paz, E., Goldberg, D. E., and Miller, B. L. (1999). The gambler's ruin problem, genetic algorithms, and the sizing of populations. *Evolutionary Computations*, 7(3):231–253.
- [Higham, 1996] Higham, N. J. (1996). *Accuracy and Stability of Numerical Algorithms*. SIAM Publisher, Philadelphia, PA.
- [Holland, 1975] Holland, J. H. (1975). *Adaptation in Natural and Artificial Systems*. University of Michigan Press, Ann Arbor.
- [Jeszensky and Stolfi, 1998] Jeszensky, P. J. E. and Stolfi, G. (1998). Cdma systems sequences optimization by simulated annealing. In *Proceedings of IEEE 5<sup>th</sup> International Symposium on Spread Spectrum Techniques and Applications*, volume 3, pages 706–708.
- [Juntti et al., 1997] Juntti, M. J., Schlosser, T., and Lilleberg, J. O. (1997). Genetic algorithms for multiuser detection in synchronous cdma. In *Proceedings of the IEEE International Symposium on Information Theory*, page 492.
- [Kuramoto et al., 2004] Kuramoto, A. S. R., Jeszensky, P. J. E., and Abrão, T. (2004). Projeto de seqüências para sistemas qs-cdma multitaxa mpeg. In *XXI Simpósio Brasileiro de Telecomunicações*, Belém, PA, Brazil. SBT.
- [Lim et al., 2003] Lim, H. S., Rao, M. V. C., Tan, A. W. C., and Chuah, H. T. (2003). Multiuser detection for ds-cdma systems using evolutionary programming. *IEEE Communications Letters*, 7(3):101–103.

- [Lim and Venkatesh, 2004] Lim, H. S. and Venkatesh, B. (2004). An effective memetic algorithm for the optimum multiuser detection problem. In *IEEE International Symposium on Spread Spectrum Techniques and Applications (ISSSTA 04)*, pages 885–889, Sydney, Australia.
- [Mitchell, 1998] Mitchell, M. (1998). *An Introduction to Genetic Algorithms*. MIT Press.
- [Moustafa et al., 2004] Moustafa, M., Habib, I., and Naghshineh, M. N. (2004). Efficient radio resource control in wireless networks. *IEEE Transactions on Wireless Communications*, 3:2385–2395.
- [Poor and S.Verdú, 1997] Poor, H. V. and S.Verdú (1997). Probability of error in mmse multiuser detection. *IEEE Transactions on Information Theory*, 43(3):858–871.
- [P.Patel and Holtzman, 1994] P.Patel and Holtzman, J. M. (1994). Analysis of a single successive interference cancellation scheme in a ds/cdma system. *IEEE Journal on Selected Areas in Communications*, 12(5):796–807.
- [Proakis, 1989] Proakis, J. (1989). *Digital Communications*. McGraw-Hill.
- [Silva et al., 2004] Silva, V. A., Abrão, T., and Jeszensky, P. J. E. (2004). Statistically correct simulation models for the generation of multiple uncorrelated rayleigh fading waveforms. In *IEEE International Symposium on Spread Spectrum Techniques and Applications (ISSSTA 04)*, pages 472–476, Sydney, Australia.
- [Tan, 2001] Tan, P. H. (2001). *Multiuser Detection in CDMA-Combinatorial Optimization Methods*. PhD thesis, Chalmers University of Technology, Göteborg. 93 p.
- [Verdú, 1986] Verdú, S. (1986). Minimum probability of error for synchronous gaussian multiple-access channels. *IEEE Transactions on Information Theory*, 32:85–96.
- [Verdú, 1998] Verdú, S. (1998). *Multiuser Detection*. Cambridge Univ. Press, Cambridge, U.K.
- [Wu et al., 2003] Wu, X., Chuah, T. C., Sharif, B. S., and Hinton, O. R. (2003). Adaptive robust detection for cdma using genetic algorithm. *IEE Proceedings Communications*, 150(6):437–444.
- [Yen and Hanzo, 2000] Yen, K. and Hanzo, L. (2000). Hybrid genetic algorithm based multiuser detection schemes for synchronous cdma systems. In *Proceeding of 51<sup>th</sup> IEEE Vehicular Technology Conference*, pages 1400–1404, Tokyo, Japan.
- [Yen and Hanzo, 2001] Yen, K. and Hanzo, L. (2001). Genetic algorithm assisted joint multiuser symbol detection and fading channel estimation for synchronous cdma systems. *IEEE Journal on Selected Areas in Communications*, 19:985–997.
- [Yen and Hanzo, 2004] Yen, K. and Hanzo, L. (2004). Genetic-algorithm-assisted multiuser detection in asynchronous cdma communications. *IEEE Trans. on Vehicular Technology*, 53(5):1413–1422.
- [Zvonar and Brady, 1996] Zvonar, Z. and Brady, D. (1996). Linear multipath-decorrelating receivers for cdma frequency-selective fading channels. *IEEE Transactions on Communications*, 44(6):650–653.