

## NOVEL DUAL-MODE DUAL-BAND BANDPASS FILTER USING DOUBLE SQUARE-LOOP STRUCTURE

Z.-X. Chen, X.-W. Dai, and C.-H. Liang

National Key Laboratory of Antennas and Microwave Technology  
Xidian University  
Xi'an 710071, China

**Abstract**—A dual-mode dual-band bandpass microstrip filter using double square-loop structure is proposed in this paper. Each of the square-loop forms a dual-mode resonator with controllable respective passband. Two tuning patches placed symmetrically at the side of the perturbation patch are used to change the higher passband frequency, while while keeping the lower invariable. Several attenuation poles in the stopband are realized to improve the selectivity of the proposed bandpass filter. The filter is evaluated by experiment and simulation with good agreement.

### 1. INTRODUCTION

Recent development in wireless communication systems has created a need of RF circuits with a dual-passband operation. Therefore, the bandpass filter, as a key component filtering unwanted frequency in RF systems, is necessary to generate two or more transmission frequency bands. Recently, the synthesis theory of microwave filters present two passbands mostly use frequency-variable transformations [1]. However, the strong attenuation is required for practical applications; Many new structures, such as stepped impedance resonators (SIRs) or parallel coupling [2, 3] or equal-length coupled-serial- shunted lines [4], have been proposed for a dual- band bandpass filter. In [5], a dual-mode dual-band bandpass filter was initially reported. Unfortunately, this solution suffers from high insertion loss and none transmission zeros in the stopband. However, an extra matching network is needed to combine them. Recently, the dual-mode resonator using patch [6] or square loop [7–9] has attracted many attentions for its low radiation and compact size in design of single band filter [11–15], which might

become a candidate for dual-band bandpass filter design. A dual-mode dual-band filter with stacked loop structure is proposed in [10]. However, the stacked loop structure may introduce higher cost and difficulty in fabrication.

In this paper, a dual-mode dual-band bandpass filter using double square-loop structure is presented. The filter provides two transmission bands, and each of them is realized using a dual-mode square-loop resonator. This structure can provide convenience to change the second passband frequency, while the first keeps same. At the same time, there is good isolation between the two passbands.

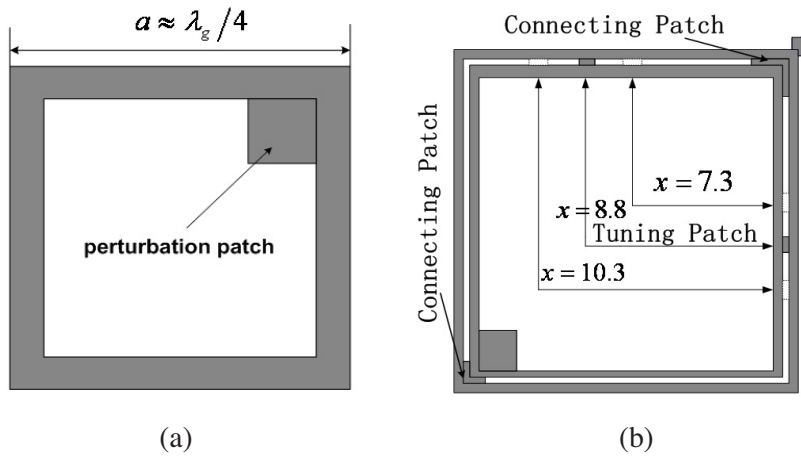

**Figure 1.** (a) Conventional dual-mode microstrip bandpass filters. (b) Proposed the structure of double square-loop.

## 2. DUAL-MODE SQUARE-LOOP RESONATORS

Dual-mode microstrip bandpass filters have been investigated by many researchers for applications in both wired and wireless communication. These filters are based on a variety of symmetric dual-mode resonating structures. For dual-mode operation, a perturbation is introduced in the resonator in order to couple its two degenerate modes. Fig. 1(a) shows the layout of conventional model of dual-mode square-loop bandpass filter [7, 10]. The square loop consists of four identical arms in length. Different filter responses can be obtained with different positions and size of the perturbation, which is analyzed in detail in [6]. The fundamental resonance occurs when  $a \approx \lambda_g/4$ , where  $\lambda_g$  is the

guided wavelength.

$$\lambda_g = \frac{c}{f\sqrt{\epsilon_{eff}}} \quad (1)$$

where  $c$  is the velocity of light in free space, and  $\epsilon_{eff}$  is the effective dielectric constant of the substrate. According to (1), for a fixed resonant frequency,  $a \approx \lambda_g/4$  is decreased to realize size reduction as  $\epsilon_{eff}$  increased. Similarly, for a fixed  $\epsilon_{eff}$ , the resonant frequency  $f$  is decreased as  $a$  increased.

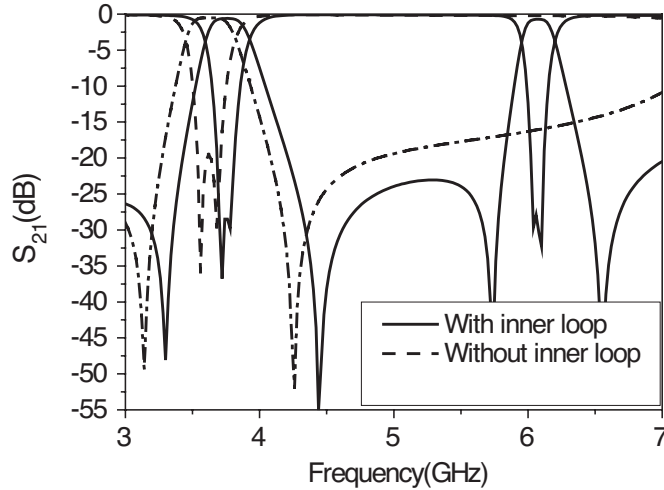

**Figure 2.** Frequency responses of outer loop with and without inner loop.

Figure 1(b) shows the proposed double square-loop structure, where the outer and inner loops have different side-length. There are two different pass bands for the proposed structure. Two connecting patches at the diagonal corners are used to feed the inner loop, and the tuning patches are located at different positions to realize the control of the second passband. Given the side-length of the outer loop, the frequency responses of the square-loop model with and without inner loop were illustrated in Fig. 2, which shows the lower passband has a slight shift to higher frequency. The waveguide wavelength corresponding to the lower passband is

$$\lambda_{g1} \approx 4a \quad (2)$$

where  $a$  is the side-length of the outer loop. The center frequency of

the lower passband is related by submitting (2) in (1).

$$f_{01} = \frac{c}{\lambda_{gl}\sqrt{\epsilon_{eff}}} \approx \frac{c}{4a\sqrt{\epsilon_{eff}}} \quad (3)$$

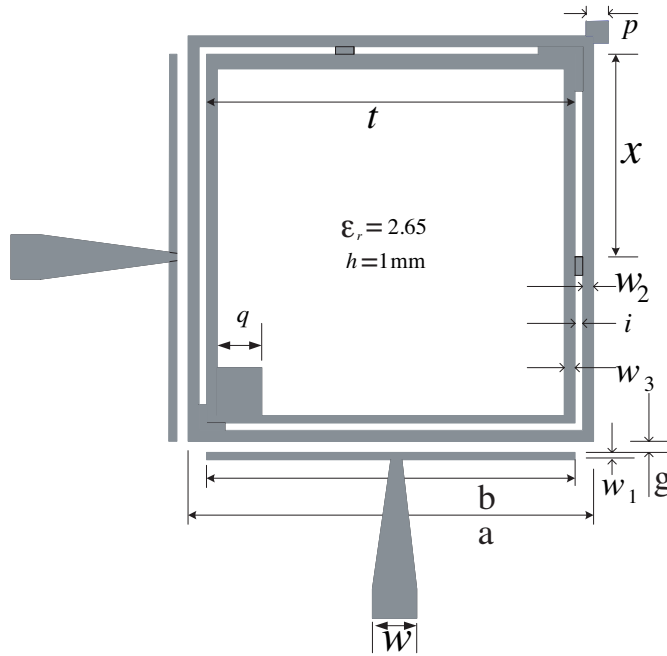

**Figure 3.** Proposed dual-mode dual-band bandpass filter.

### 3. PROPOSED BANDPASS FILTER DESIGN

The structure of the proposed dual-mode dual-band bandpass filter is shown in Fig. 3, whose design parameters were determined as follows:  $a = 15$  mm,  $b = 14.2$  mm,  $g = 0.25$  mm,  $w_1 = 0.3$  mm,  $w_2 = 0.4$  mm,  $p = 0.5$  mm,  $w_3 = 0.3$  mm,  $d = 1.2$  mm,  $t = 13.6$  mm and  $w = 2.8$  mm is the width of  $50\Omega$  microstrip feedline. The outer loop and inner loop provide two transmission paths for RF signal. Based on the discussion mentioned above, the proposed filter generates two separated passbands by using two square loops resonating different frequency, the outer loop for lower passband, and the inner loop for higher passband. Changing the place of tuning patches, we can control the location of higher passband. Due to the

tuning patches, the resonating length of inner loop can be changed. The simulation and experiment results disclose that the waveguide wavelength corresponding to the higher passband should satisfy the relation

$$\lambda_{g2} \approx 4t - 2x \quad (4)$$

where  $t$  is the side-length of the inner loop and  $x$  is distance between the tuning patch and the outer perturbation corner. Submit (4) in (1), the center frequency of the higher passband is deduced as

$$f_{02} = \frac{c}{\lambda_{gh}\sqrt{\epsilon_{eff}}} \approx \frac{c}{(4t - 2x)\sqrt{\epsilon_{eff}}} \quad (5)$$

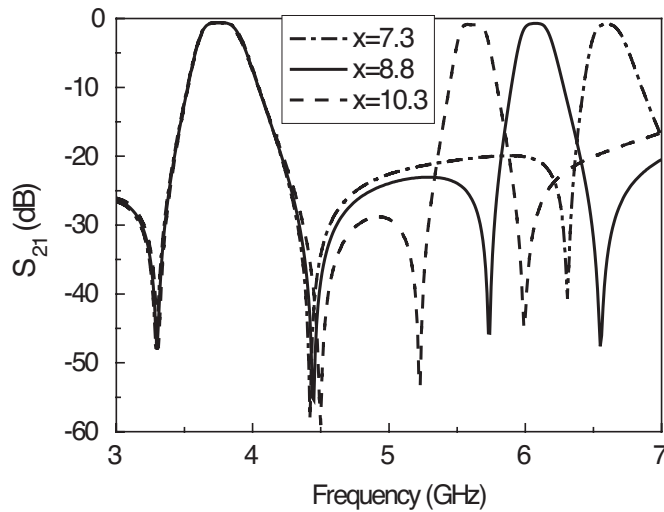
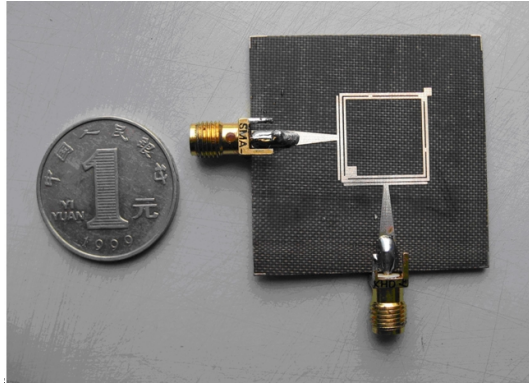

**Figure 4.** Different frequency responses with variation of  $x$ .

Figure 4 shows the variation of the location of the higher passband frequency with the different  $x$ . The higher passband frequency is increased as  $x$  is enlarged, while the lower passband keeps the same. So the operating frequency of higher passband can be easily controlled. In addition, each dual-mode loop generates own passband and two attenuation poles at respective stopbands, which keeps good selectivity of the proposed filter. In order to reduce the coupling between the two perturbation patches and the mutual effects of the two passbands, the two patches are located at inner corner of the inner loop and outer corner of the outer loop, respectively. A demonstration filter is optimized and measured when  $x = 8.3$  mm. Good agreements between the simulation and measurement are achieved.

#### 4. SIMULATED AND MEASURED RESULTS

The simulation and measurement are accomplished by using simulator IE3D V10 and Agilent 8719ES network analyzer. Fig. 5 shows the photograph of the fabricated dual-mode dual-band bandpass filter with  $x = 8.3$  mm in Fig. 3. The simulated and measured results are shown in Fig. 6. The two passbands centered at 3.74 GHz and 6.30 GHz, respectively. Four attenuation poles at 3.29, 4.44, 5.96



**Figure 5.** Photograph of the fabricated dual-mode dual-band filter.

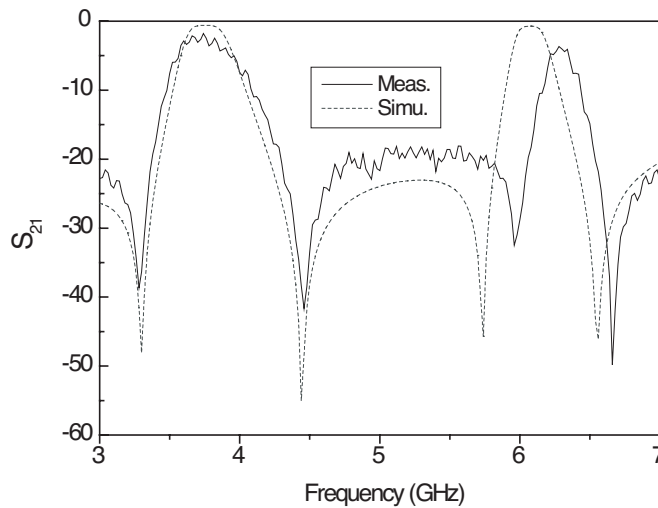

**Figure 6.** Comparison of the simulated and measured results.

and 6.66 GHz are realized, which can greatly improve the selectivity of the proposed dual-mode dual-band bandpass filter. The insertion loss in passband is mainly due to the conductor loss of the hairpin resonators. Compared with simulation results, the higher passband and attenuation poles slightly shift to the higher frequency due to the inaccuracy in fabrication and implementation.

## 5. CONCLUSION

In this paper, a dual-mode dual-band bandpass filter using a double square-loop structure is presented. The two dual-mode loop resonators generate respective passbands, and it can easily change the higher bandpass frequency by changing the location of the tuning patch. Although the square-loop structure has been previously applied to filters, the double square-loop structure has not been investigated. Numerical simulations using IE3D show good agreements with experiments. It testified that the proposed microstrip filter can provide good selection and convenience of tuning the higher bandpass frequency. The tuning patch can provide convenience in filter designing and debugging. The good agreement between the simulated and measured results demonstrates our proposed structure.

## ACKNOWLEDGMENT

This work is supported by the National Natural Science Foundation of China (NSFC) under Contract No. 60501023.

## REFERENCES

1. Levy, R., "Zolotarev functions, a new distribution prototype filter, and the design of mixed lumped/distributed components," *IEEE G-MTT Microwave Int. Symp. Dig.*, Vol. 70, 71–75, 1970.
2. Wang, J., Y.-X. Guo, B.-Z. Wang, L. C. Ong, and S. Xiao, "High-selectivity dual-band stepped-impedance bandpass filter," *Electronics Letters*, Vol. 42, No. 9, 538–540, April 2006.
3. Sun, S. and L. Zhu, "Novel design of dual-band microstrip bandpass filters with good in-between isolation," *IEEE APMC 2005*, Suozhou, 2005.
4. Tsai, L.-C. and C.-W. Hsue, "Dual-band bandpass filters using equallength coupled-serial-shunted lines and z-transform techniques," *IEEE Trans. Microw. Theory Tech.*, Vol. 52, No. 4, 1111–1117, Apr. 2004.

5. Tu, W.-H. and K. Chang, "Miniaturized dual-mode bandpass filter with harmonic control," *IEEE Microwave and Wireless Components Letters*, Vol. 15, No. 12, December 2005.
6. Hong, J.-S. and M. J. Lancaster, "Microstrip triangular patch resonator filters," *IEEE MTT-S International Microwave Symposium Digest, 2000*, Vol. 1, 331–334, June 2000.
7. Görür, A., "Description of coupling between degenerate modes of a dual-mode microstrip loop resonator using a novel perturbation arrangement and its dual-mode bandpass filter applications," *IEEE Trans. Microw. Theory Tech.*, Vol. 52, No. 2, 671–677, Feb. 2004.
8. Hong, J. S. and M. J. Lancaster, "Realization of quasielliptic function filter using dual-mode microstrip square loop resonators," *Electron. Lett.*, Vol. 31, 2085–2086, Nov. 1995.
9. Hsieh, L.-H. and K. Chang, "Compact dual-mode elliptic-function bandpass filter using a single ring resonator with one coupling gap," *Electron. Lett.*, Vol. 36, 1626–1627, Sep. 2000.
10. Chen, J.-X. and T. Y. Yum, "Dual-mode dual-band bandpass filter using stacked-loop structure," *IEEE Microwave and Wireless Components Letters*, Vol. 16, No. 9, September 2006.
11. Stewart, J. W. and M. J. Havrilla, "Electromagnetic characterization of a magnetic material using an open-ended waveguide probe and a rigorous full-wave multimode model," *J. of Electrom. Waves and Appl.*, Vol. 20, No. 14, 2037–2052, 2006.
12. Xiao, J.-K., S.-P. Li, and Y. Li, "Novel planar bandpass filters using one single patch resonators with corner cuts," *J. of Electrom. Waves and Appl.*, Vol. 20, No. 11, 1481–1493, 2006.
13. Xiao, J.-K. and Y. Li, "Novel compact microstrip square ring bandpass filters," *J. of Electrom. Waves and Appl.*, Vol. 20, No. 13, 1817–1826, 2006.
14. Kazerooni, M. and A. Cheldavi, "Simulation, analysis, design and applications of array defected microstrip structure (ADMS) filters using rigorously coupled multi-strip (RCMS) method," *Progress In Electromagnetics Research*, PIER 63, 193–207, 2006.
15. Khalaj-Amirhosseini, M., "Microwave filters using waveguides filled by multi-layer dielectric," *Progress In Electromagnetics Research*, PIER 66, 105–110, 2006.