

ТРАНСПОРТНЕ БУДІВНИЦТВО

UDC 624.94.014.2:519.6

D. V. ROZUMENKO¹, D. O. BANNIKOV^{2*}

¹Fac. «Industrial and Civil Engineering», Dnipro National University of Railway Transport named after Academician V. Lazaryan, Lazaryana St., 2, Dnipro, Ukraine, 49010, tel. +38 (099) 681 68 38, e-mail dmitriy.rozumenko.v@gmail.com, ORCID 0000-0001-6058-9417

^{2*}Dep. «Construction Production and Geodesy», Dnipro National University of Railway Transport named after Academician V. Lazaryan, Lazaryana St., 2, Dnipro, Ukraine, 49010, tel. +38 (063) 400 43 07, e-mail bdo2020@yahoo.com, ORCID 0000-0002-9019-9679

DYNAMIC PROPERTIES OF ONE-STOREY INDUSTRIAL BUILDING

Purpose. Recently, there has been a growing demand in Ukraine for the reuse of industrial buildings that have not been in exploitation for a certain period of time. At the same time, there are frequent cases when new technological equipment transfers significant dynamic loads to existing structures over a long period of time. Since the available data regarding the dynamic properties of industrial buildings are now practically absent, the main goal of the studies made by the authors is to evaluate and analyze own dynamic characteristics of a one-storey industrial building. **Methodology.** To achieve this goal, it was necessary first to choose the type of industrial building, which is common enough for the formulated conditions of the reuse possibility. A one-storey unheated industrial building with three purlins (purlins 15 + 15 + 6 m) with a steel supporting frame was taken as such a building. In the course of research, the cross sections of the main load-bearing elements were varied, as well as the schemes of their connection with each other. The calculations were carried out by the finite element method based on the Lira for Windows project complex. **Findings.** The obtained frequency spectra of the own dynamic characteristics for the main bearing structural elements of an industrial building of the type in question are in the range up to 30 Hz. Also, during the research, dependencies were obtained for changing this range for various cases of design decisions of the building. **Originality.** The research results presented in the publication make it possible to evaluate the range of the own dynamic characteristics of single-storey multipurlined unheated industrial buildings with the traditional structural solution of the steel frame. **Practical value.** The resulting range of the own dynamic characteristics of the industrial building of the type in question is quite dangerous for human health. The most unfavorable is the oscillation form of the columns, which actually involves the entire structural frame. Therefore, in the course of research, a special method was developed and tested to stabilize such vibrations «on the base» using flexible ropes.

Keywords: industrial building; modal analysis; dynamic characteristics; finite element method; complex Lira for Windows

Introduction

Today, a significant number of industrial buildings of various types and purposes were accumulated in Ukraine, which have not been in operation for a long time. Their construction falls on the second half of the twentieth century, and the corresponding space-planning and design solutions also meet the requirements of this period.

The desire of modern private companies to save some money while developing their own business-

es leads to the reuse of such buildings. At the same time, the available space-planning and design solutions they remain unchanged, trying to use them with modern production technologies. This approach is quite often implemented without any specialized project, without further professional calculations and even without basic feasibility studies.

As a result, the new technological equipment is placed directly on the existing elements of the supporting structures, it is attached virtually without

ТРАНСПОРТНЕ БУДІВНИЦТВО

special design decisions. Quite often the duration of continuous operation of the equipment is measured by hours, and in some cases its operation is round the clock. At the same time, one of the factors in the operation of such equipment is often the dynamic impact caused by its moving parts.

The main component of such a dynamic impact is the vibration, which manifests itself in the form of transmission of the dynamic loading with a certain amplitude-frequency spectrum to the structural elements. As a consequence, the static work of load-bearing structures of the building, provided by the design and engineering documentation, is disrupted, transforming into a dynamic work.

The consequences of such a situation are manifested in a short period of time in the form of various damage and failure of the supporting structure elements, disruption of their proper functioning.

Purpose

Taking into account the above-mentioned, the main purpose of our study is to evaluate the dynamic characteristics of a one-storey industrial building.

To achieve this goal, it was necessary to first select the type of industrial building, which is quite common for the formulated conditions of the reuse possibility, and then to conduct a modal analysis of its design solution.

Methodology

A single-storey, unheated industrial building with three purlins of 15 + 15 + 6 m was selected for the study. Its design solution is framed with the use of classical arrangement, which is described in detail in many professional sources, for example, [6]. The load-bearing elements are transverse frames, spaced in 5.3 m increments. The edge columns are made with a solid cross-section; valley stanchions have a two-stage construction with an in-through bottom. Trusses with a diagonal lattice, additional vertical posts and top cord slopes of 8.8° (15.6%) and 14.4° (25.8%), which, incidentally, is contrary to modern requirements [14], are provided as a ledger. The general view and design of the building under consideration are shown in Fig. 1. The material of the load-bearing elements of the frame was chosen steel, which is related to its lower logarithmic decrement of damping oscillations

in comparison with reinforced concrete or wood [9, 10].

It should be noted that this type of industrial buildings with small purlins is also widespread and popular in our time abroad [13].

The study was conducted in several stages, each of which evaluated own dynamic characteristics of the building under consideration.

At the *first stage*, the influence of the building length was assessed. Herewith, three cases were considered: building with the 4-step length of load-bearing transverse frames (the main variant), 6 and 10 steps, which made the total length of the building of 21.2; 31.8 and 53 m respectively.

At the *second stage*, the influence of the connection of the load-bearing transverse frame of the building with the foundation was assessed. Two cases of rigid and hinge connection are considered.

At the *third stage*, the influence of the rigidity of the main structural elements of the building – truss, column, crane beam, as well as roof purlins and longitudinal struts – was assessed.

To perform all these variant calculations, we used extremely popular in recent decades and tested numerical method of construction mechanics. It is the finite element method [12, 15, 17] based on the widely known domestic software complex Lira for Windows [11].

The constructed design model for the basic structural variant of the production building is shown in Fig. 2. All structural elements are simulated using rod finite elements of universal type from the standard library of the complex. The calculations were performed in geometrically and physically linear form. This approach avoided the issues of estimating the results convergence characteristic of finite elements of other types [4, 5].

It should be noted separately that performing dynamic calculations of building constructions is not regulated by any normative documents in our time. The current standard for designing steel structures in Ukraine [3] contains only guidance on the feasibility of their performance, but does not specify either the methods or the extent of their performance. The Ukrainian standard for determining the structural loading [2] contains no guidance at all on the calculation of dynamic loadings. The standard for determining seismic loadings [1] partially fill this gap, but such calculations are of a specific nature and are not suitable for perform-

ТРАНСПОРТНЕ БУДІВНИЦТВО

ing, for example, modal analysis of spatial building structures, which also include single-storey industrial buildings under consideration. Therefore, it is often necessary to borrow certain techniques and methods from other industries, first of all – mechanical engineering [16]. In particular, supreme frequency screening algorithms were applied, and only the first natural frequencies were taken into account.

Findings

The results of modal analysis for all three stages of research are summarized in Table 1. The lower natural partial frequencies for the basic structural elements are presented. In Fig. 3 – 6 the oscillation forms of the basic structural elements for the case shown in Table 1 in dark color are presented. For all other cases, the fluctuation forms were qualitatively identical.

a*b*

Fig. 1. The object research – one-storey industrial building:
a – general view; *b* – design solution

Table 1

**Natural frequency spectrum of a one-storey
production building (Hz)**

Connection	Rigid						Hinge
Frame spacing	4				6	10	4
Section of truss members	square	square	circle	angles	square	square	square
	initial	Changed with reduced rigidity					
Element of building							
Truss	0.509	0.344	0.306	0.297	0.307	0.296	0.343
Column	2.787	1.978	1.867	1.881	1.961	1.847	1.977
Roof purlins	5.203	4.269	4.288	4.288	4.288	4.288	4.269
Crane beam	7.164	5.695	5.599	5.608	5.595	5.591	5.692
Struts	25.401	22.384	22.448	22.577	22.465	22.128	22.410

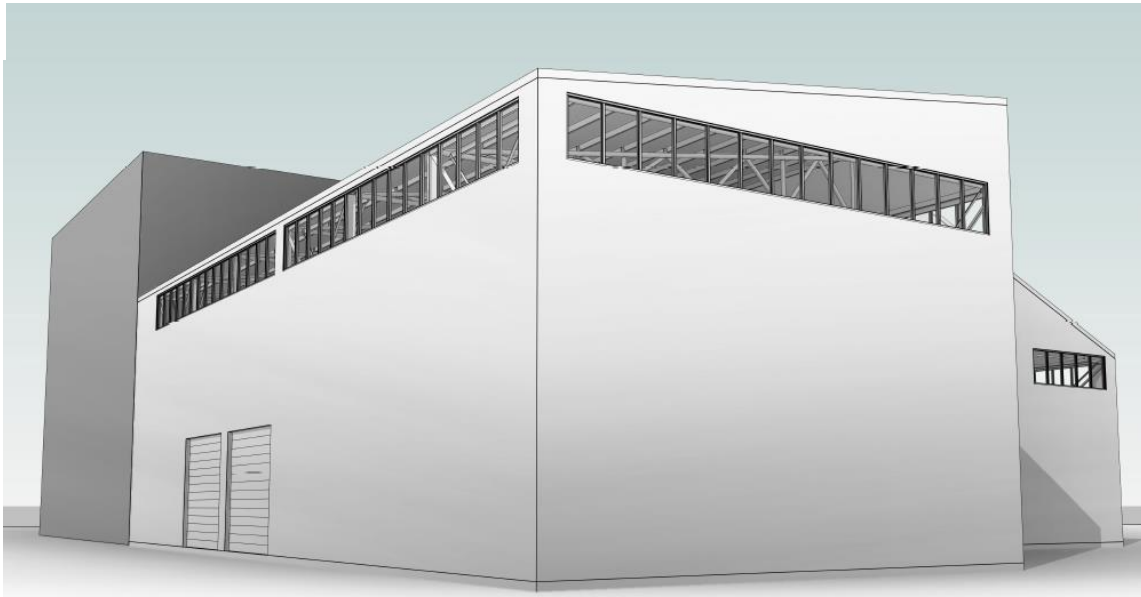
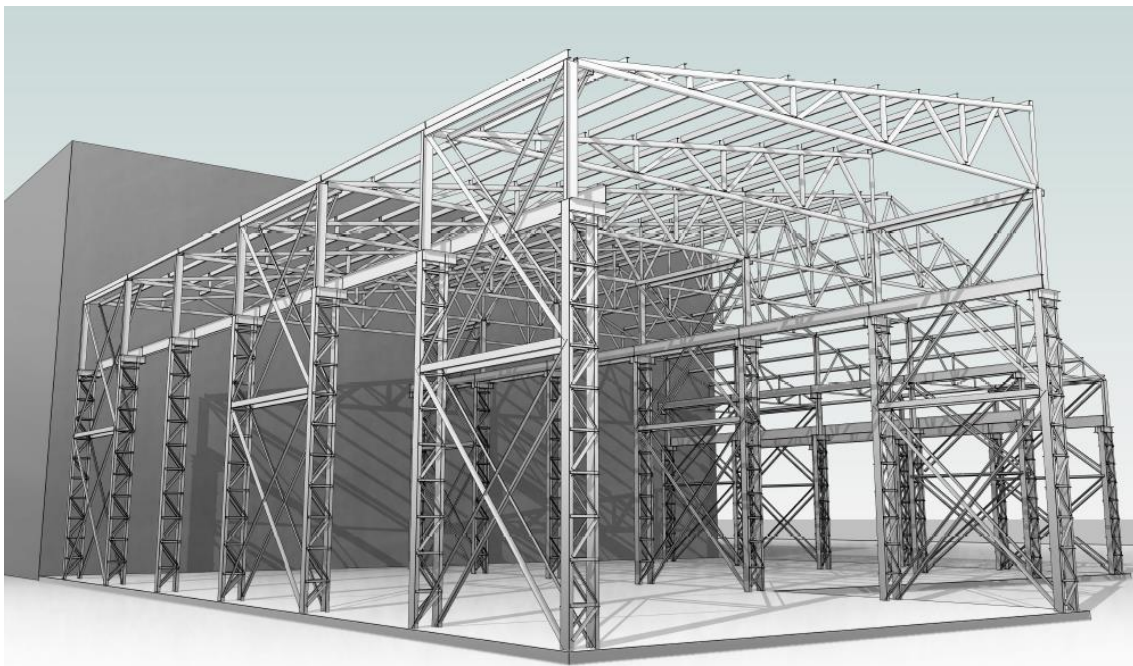
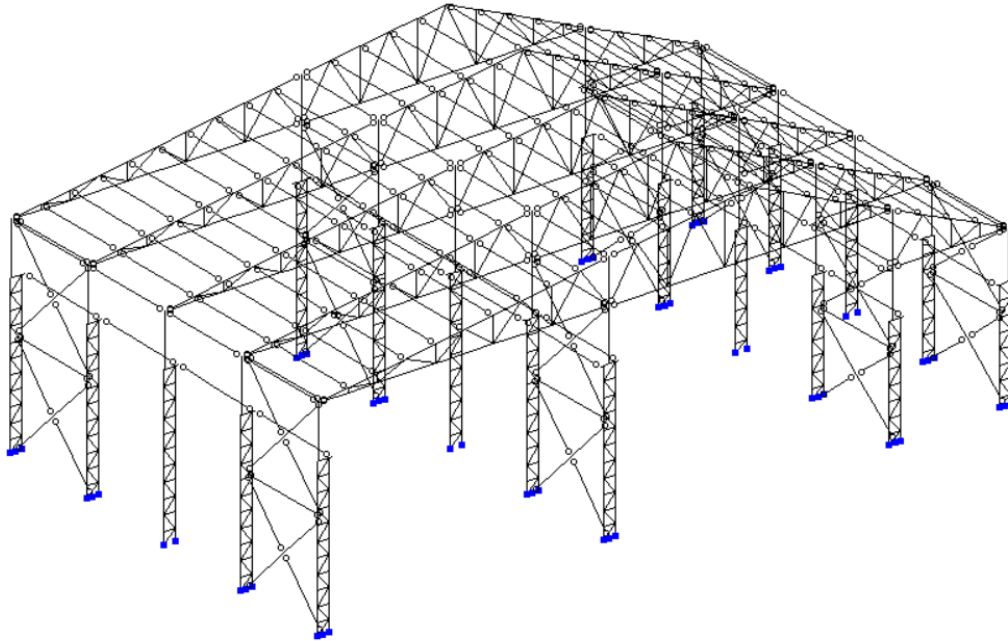

Fig. 2. Finite element model of industrial building

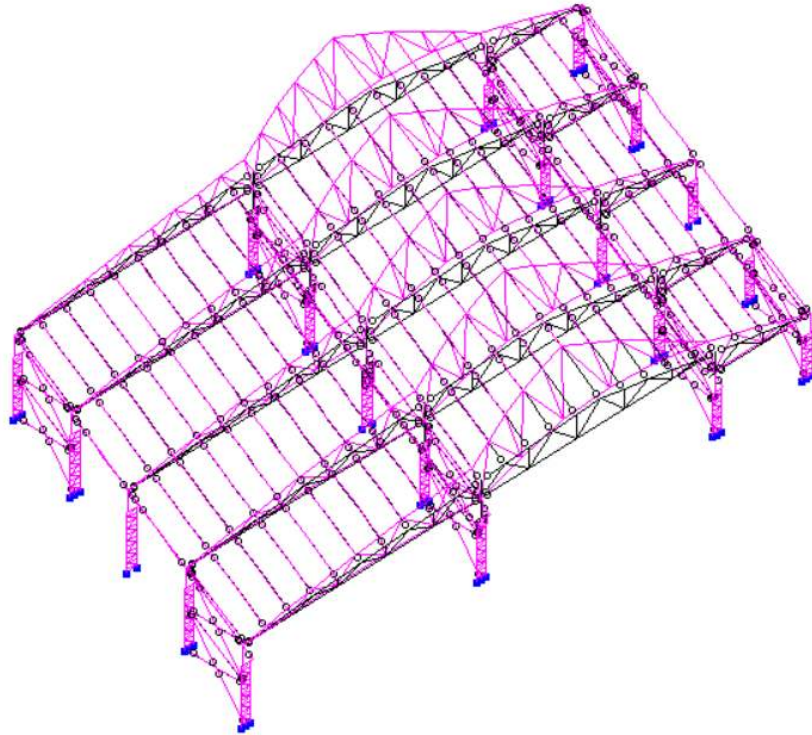

Fig. 3. The obtained lowest oscillation form of trusses of industrial building

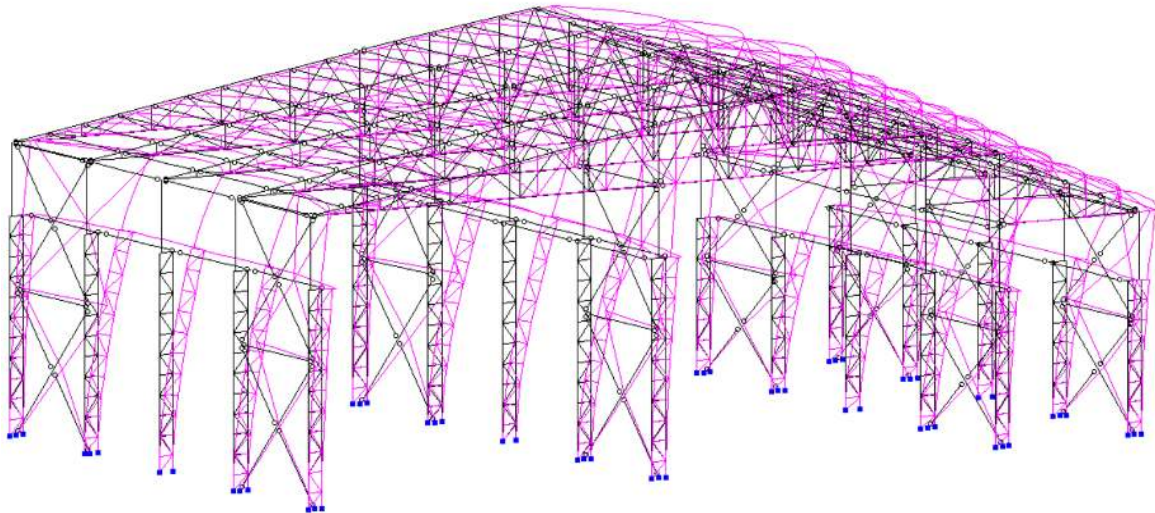

Fig. 4. The obtained lowest oscillation form of columns of industrial building

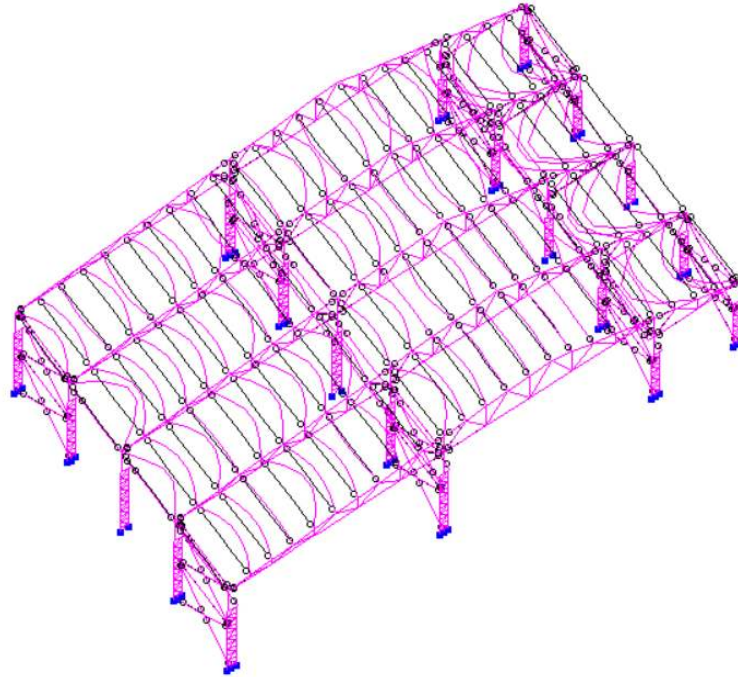

Fig. 5. The obtained lowest oscillation form of roof purlins of industrial building

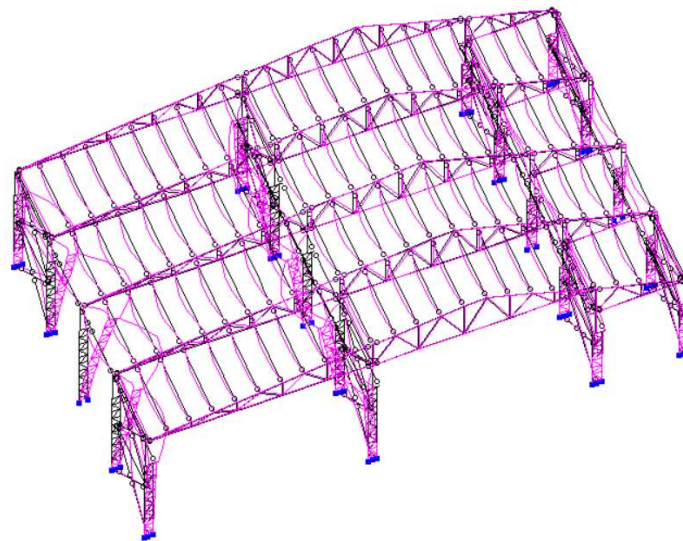

Fig. 6. The obtained lowest oscillation form of crane beams of industrial building

As can be seen from the obtained data, the frequency spectrum is in rather dangerous range for the human, which is presented in Table 2 according to the data of the work [8]. However, the impact on it of all the factors considered – the building length, the nature of connection to the foundation and the rigidity of the structural elements – is quite insignificant.

The most dangerous was the oscillation form of the columns of industrial building, which in fact involves the whole structural framework. The frequency of such oscillations is also the most dangerous. Therefore, at the *fourth stage* of the research the stabilization of this form was considered in more detail.

Table 2

Natural human frequency spectrum (Hz)

No.	Human organ	Resonant frequency
1	Vestibular apparatus	0.5–13
2	Stomach	2–3
3	Intestines	2–4
4	Body	2–5
5	Heart	4–6
6	Kidneys	6–8
7	Head	20–30
8	Eyebulbs	60–90

Of all the modern methods of stabilization in accordance with the work [7], the most effective for the conditions of the studied industrial building is the structural one. The authors have developed and tested a way to stabilize the «base» using the flexible ropes – Fig. 7.

In this case, the natural partial oscillation frequency increased to 5.136 Hz, which reduced its potential effect on human. The new form of oscillation for this case is shown in Fig. 8.

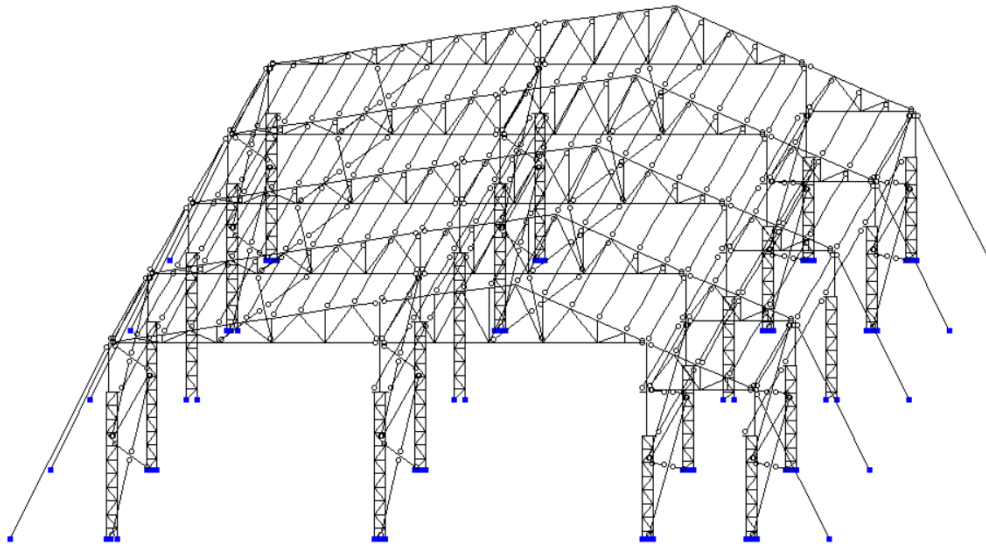

Fig. 7. Finite element model of industrial building with additional ropes to stabilize «on the base»

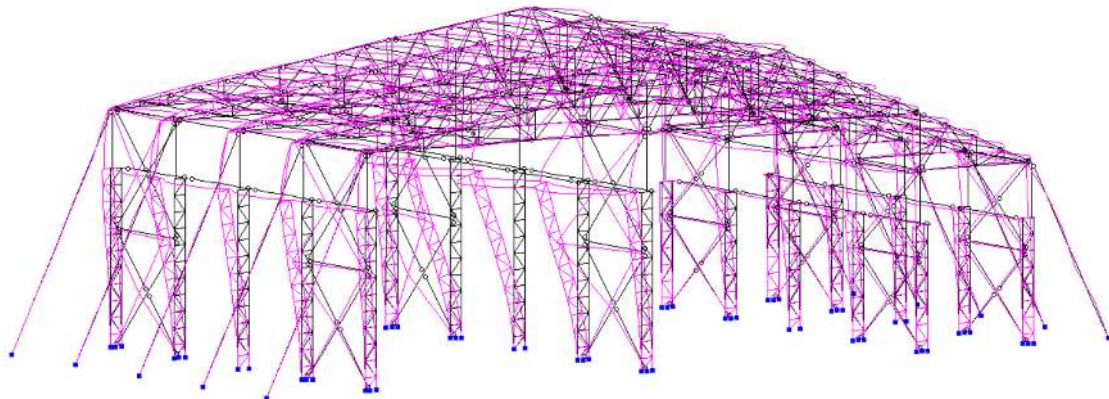

Fig. 8. The obtained oscillation form of the industrial building with additional ropes to stabilize the «base»

Originality and practical value

The results of the studies presented in the publication allow us to estimate the spectrum of natural dynamic characteristics of single-storey multi-purlined unheated industrial buildings with the traditional structural design of the steel frame. As the obtained range of natural dynamic characteristics of the industrial building of the investigated type is rather unsafe for human health, the authors have developed a way of shifting the frequency spectrum to a safer zone. It consists in applying the stabilization of the most unfavorable form of columns' oscillation in industrial building «on the base» by means of flexible ropes. The effectiveness of this decision was confirmed during the studies performed.

It should also be noted that this structural proposal is quite simple in terms of practical implementation and can be applied not only to industrial buildings with steel bearing frame, but also to other types of existing frame buildings, in particular for civilian or agricultural purposes.

Conclusions

Based on the material stated in the publication, we can draw the following conclusions:

1. The spectrum of natural dynamic characteristics of a single-storey non-heated industrial building with a bearing steel frame is quite dense and for the lower frequencies (up to 30 Hz) it is presented for all the basic structural elements. This is potentially hazardous to human health because the spectrum obtained is quite consistent with that of human resonance characteristics.

2. The influence on the own dynamic characteristics of industrial building of the type under consideration, such as the building length, the connection nature with the foundation, and the rigidity of the structural elements, are quite insignificant.

3. In order to stabilize the most unfavorable oscillation form of the frame of the industrial building under consideration, a method of stabilizing «on the base» using the flexible ropes was proposed and tested by numerical calculations. It also makes it possible to shift the appropriate frequency spectrum to a safer zone.

LIST OF REFERENCE LINKS

1. Банніков Д. О. Оцінка практичної збіжності результатів аналізу пластинчастих моделей в методі скінчених елементів. *Нові технології в будівництві*. 2017. № 32. С. 26–31.
2. Банников Д. О., Гуслистая А. Э. Оценка сходимости напряжений в сложных металлоконструкциях методом конечных элементов. *Металлургическая и горнорудная промышленность*. 2011. № 4. С. 93–96.
3. Буга П. Г. *Гражданские, промышленные и сельскохозяйственные здания* : монографія. Москва : Книга по требованию, 2013. 349 с.
4. ДБН В.1.1-12:2006. *Захист від небезпечних геологічних процесів, шкідливих експлуатаційних впливів, від пожежі. Будівництво у сейсмічних районах України*. [Чинний від 2007-01-02]. Вид. офіц. Київ : Мін. буд-ва, арх-ри та ЖКГ України, 2006. 84 с.
5. ДБН В.1.2-2-2006 (зі змінами). *Система надійності та безпеки в будівництві. Навантаження і впливи. Норми проектування*. [Чинний від 2007-01-01]. Вид. офіц. Київ : Держбуд, 2007. 70 с.
6. ДБН В.2.6-198:2014. *Сталеві конструкції. Норми проектування*. [Чинний від 2015-01-01]. Вид. офіц. Київ : Мінрегіон, 2014. 205 с.
7. Казакевич М. И., Кулябко В. В. *Введение в виброэкологию зданий и сооружений* : монографія. Днепропетровск : ПГАСА, 1996. 200 с.
8. Казакевич М. И. Проблемы стабилизации вант. *Металлические конструкции*. 2011. Т. 17. № 2. С. 63–84.
9. Редченко В. П. *Динамічні випробування мостів. Частина 1 : Загальні положення, спектральний аналіз, динамічні характеристики* : монографія. Дніпро : Пороги, 2016. 216 с.
10. Редченко В. П. *Динамічні випробування мостів. Частина 2 : Вільні коливання, модальний контроль* : монографія. Дніпро : Пороги, 2017. 216 с.
11. Стрелец–Стрелецкий Е. Б., Журавлев А. В., Водопьянов Р. Ю. *ЛИРА–САПР. Книга 1 : Основы* : монографія / под ред. А. С. Городецкого. Киев : LIRALAND, 2019. 154 с.
12. Vofang Z. *The Finite Element Method. Fundamentals and Applications in Civil, Hydraulic, Mechanical and Aeronautical Engineering*. Singapore : John Wiley & Sons Singapore Pte. Ltd. 2018. 843 p.
DOI: <https://doi.org/10.1002/9781119107323>

ТРАНСПОРТНЕ БУДІВНИЦТВО

13. Johnson R. P. *Composite Structures of Steel and Concrete: Beams, Slabs, Columns and Frames for Buildings* : monograph. Wiley Blackwell, 2018. 265 p. DOI: <https://doi.org/10.1002/9781119401353>
14. Kruhlikova N. G., Bannikov D. O. Rational design of shot-span industrial building roof for reconstruction conditions. *Наука та прогрес транспорту*. 2019. № 2 (80). P. 144–152. DOI: <https://doi.org/10.15802/stp2019/165853>
15. Neduzha L. O., Shvets A. O. Theoretical and experimental research of strength properties of spine beam of freight cars. *Наука та прогрес транспорту*. 2018. № 1 (73). P. 131–147. DOI: <https://doi.org/10.15802/stp2018/123457>
16. Shames I. H. *Energy and Finite Element Methods In Structural Mechanics* : monograph. New York : Routledge, 2017. 776 p. DOI: <https://doi.org/10.1201/9780203757567>
17. Singiresu S. R. *The Finite Element Method in Engineering* : monograph. Elsevier Inc, 2018. 763 p. DOI: <https://doi.org/10.1016/c2016-0-01493-6>

Д. В. РОЗУМЕНКО¹, Д. О. БАННИКОВ^{2*}

¹Фак. «Промислове та цивільне будівництво», Дніпровський національний університет залізничного транспорту імені академіка В. Лазаряна, вул. Лазаряна, 2, Дніпро, Україна, 49010, тел. +38 (099) 681 68 38, ел. пошта dmitriy.rozumenko.v@gmail.com, ORCID 0000-0001-6058-9417

^{2*}Каф. «Будівельне виробництво та геодезія», Дніпровський національний університет залізничного транспорту імені академіка В. Лазаряна, вул. Лазаряна, 2, Дніпро, Україна, 49010, тел. +38 (063) 400 43 07, ел. пошта bdo2020@yahoo.com, ORCID 0000-0002-9019-9679

ДИНАМІЧНІ ВЛАСТИВОСТІ ОДНОПОВЕРХОВОЇ ВИРОБНИЧОЇ БУДІВЛІ

Мета. Зараз в Україні зростає попит на повторне використання промислових будівель, які протягом певного часу не були в експлуатації. При цьому частими є випадки, коли нове технологічне обладнання передає на наявні конструкції значні динамічні навантаження протягом тривалого часу. Оскільки дані щодо динамічних властивостей виробничих будівель на сьогодні практично відсутні, основною метою нашого дослідження є оцінка власних динамічних характеристик одноповерхової виробничої будівлі. **Методика.** Для досягнення поставленої мети необхідно було спочатку обрати тип виробничої будівлі, який є доволі розповсюдженим для сформульованих умов можливості повторного використання. За таку будівлю було взято одноповерхову трипрогонову неопаловану виробничу будівлю (прогони 15 + 15 + 6 м) зі сталевим несучим каркасом. У ході досліджень варіювались перерізи основних несучих елементів, а також схеми їх з'єднання між собою. Розрахунки виконано методом скінченних елементів на базі проектного комплексу Lira for Windows. **Результати.** Отримані частотні спектри власних динамічних характеристик основних несучих конструктивних елементів для виробничої будівлі розглядуваного типу перебувають у діапазоні до 30 Гц. Також у ході досліджень отримані залежності для зміни цього діапазону для різних випадків проектно-конструкторських рішень будівлі. **Наукова новизна.** Представлені в публікації результати досліджень дозволяють оцінити спектр власних динамічних характеристик одноповерхових багатопрогонів неопалованих виробничих будівель із традиційним конструктивним рішенням сталевих каркасів. **Практична значимість.** Отриманий діапазон власних динамічних характеристик виробничої будівлі розглядуваного типу виявляється доволі небезпечним для здоров'я людини. Найбільш несприятливою є форма коливань колон, яка фактично залучає до роботи весь конструктивний каркас. Тому в ході досліджень було розроблено та перевірено спеціальний спосіб стабілізації таких коливань «на основу» за допомогою гнучких канатів.

Ключові слова: виробничі будівлі; модальний аналіз; динамічні характеристики; метод скінченних елементів; комплекс Lira for Windows

Д. В. РОЗУМЕНКО¹, Д. О. БАННИКОВ^{2*}

¹ Фак. «Промышленное и гражданское строительство», Днепропетровский национальный университет железнодорожного транспорта имени академика В. Лазаряна, ул. Лазаряна, 2, Днипро, Украина, 49010, тел. +38 (099) 681 68 38, эл. почта dmitriy.rozumenko.v@gmail.com, ORCID 0000-0001-6058-9417

^{2*} Каф. «Строительное производство и геодезия», Днепропетровский национальный университет железнодорожного транспорта имени академика В. Лазаряна, ул. Лазаряна, 2, Днипро, Украина, 49010, тел. +38 (063) 400 43 07, эл. почта bdo2020@yahoo.com, ORCID 0000-0002-9019-9679

ДИНАМИЧЕСКИЕ СВОЙСТВА ОДНОЭТАЖНОГО ПРОИЗВОДСТВЕННОГО ЗДАНИЯ

Цель. В последнее время в Украине растет спрос на повторное использование промышленных зданий, которые на протяжении определенного периода времени не пребывали в эксплуатации. При этом нередки случаи, когда новое технологическое оборудование передает на существующие конструкции значительные динамические нагрузки на протяжении длительного времени. Поскольку данные относительно динамических свойств производственных зданий на сегодня практически отсутствуют, основной целью нашего исследования является оценка собственных динамических характеристик одноэтажного производственного здания. **Методика.** Для достижения поставленной цели необходимо было сначала выбрать тип производственного здания, который является достаточно распространенным для сформулированных условий возможности повторного использования. В качестве такого здания было принято одноэтажное трехпролетное неотапливаемое производственное здание (пролеты 15 + 15 + 6 м) со стальным несущим каркасом. В ходе исследований варьировались сечения основных несущих элементов, а также схемы их соединения между собой. Расчеты выполнены методом конечных элементов на базе проектного комплекса Lira for Windows. **Результаты.** Полученные частотные спектры собственных динамических характеристик основных несущих конструктивных элементов для производственного здания рассматриваемого типа находятся в диапазоне до 30 Гц. Также в ходе исследований получены зависимости для изменения этого диапазона для различных случаев проектно-конструкторских решений здания. **Научная новизна.** Представленные в публикации результаты исследований позволяют оценить спектр собственных динамических характеристик одноэтажных многопролетных неотапливаемых производственных зданий с традиционным конструктивным решением стального каркаса. **Практическая значимость.** Полученный диапазон собственных динамических характеристик производственного здания рассматриваемого типа оказывается достаточно опасным для здоровья человека. Наиболее неблагоприятной является форма колебаний колонн, которая фактически вовлекает в работу весь конструктивный каркас. Поэтому в ходе исследований был разработан и проверен специальный способ стабилизации таких колебаний «на основании» с помощью гибких канатов.

Ключевые слова: производственное здание; модальный анализ; динамические характеристики; метод конечных элементов; комплекс Lira for Windows

REFERENCES

1. Bannikov, D. O. (2017). Ocinka praktychnoji zbitzhnosti rezul'tativ analizu plastynchastykh modelej v metodi skinchenykh elementiv. *New Technologies in Construction*, 32, 26-31. (in Ukrainian)
2. Bannikov, D. O., & Huslista, G. E. (2011). Otsenka skhodimosti napryazheniy v slozhnykh metallokonstruktsiyakh metodom konechnykh elementov, *Metallurgical and Mining Industry*, 4, 93-96. (in Russian)
3. Buga, P. G. (2013). *Grazhdanskie, promyshlennye i selskokhozyaystvennye zdaniya: monografiya*. Moscow: Kniga po trebovaniyu. (in Russian)
4. *Zakhyst vid nebezpechnykh gheologichnykh procesiv, shkidlyvykh ekspluatacijnykh vplyviv, vid pozhezhi. Budivnytstvo u sejsmichnykh rajonakh Ukrajinu*, 84 DBN B. 1.1-12:2006 (2006). (in Ukrainian)
5. *Systema nadiinosti ta bezpeky v budivnytstvi. Navantazhennia i vplyvy. Normy proektuvannia*, 70 DBN B.1.2-2:2006 (2007). (in Ukrainian)
6. *Stalevi konstruktsii. Normy proektuvannia*, 205 DBN B.2.6-198:2014 (2014). (in Ukrainian)
7. Kazakevitch, M. I., & Kuljabko, V. V. (1996). *Vvedenie v vibroekologiyu zdaniy i sooruzheniy*: monografiya. Dnepropetrovsk, PGASA. (in Russian)
8. Kazakevitch, M. I. (2011). Problems of cable stabilization. *Metall Structures*, 17(2), 63-84. (in Russian)

ТРАНСПОРТНЕ БУДІВНИЦТВО

9. Redchenko, V. P. (2016). *Dynamichni vyprobuvannja mostiv. Zaghaljni polozhennja, spektralnyj analiz, dynamichni kharakterystyky: monohrafija. Part 1.* Dnipro, Porogi. (in Ukrainian)
10. Redchenko, V. P. (2017). *Dynamichni vyprobuvannja mostiv. Viljni kolyvannja, modalnyj kontrolj: monohrafija. Part 2.* Dnipro, Porogi. (in Ukrainian)
11. Strelec-Streleckij, E. B., Zhuravlev, A. V., & Vodop'janov, R. Ju. (2019). *LIRA-SAPR. Kniga 1. Osnovy.* Kiev: LIRALAND. (in Russian)
12. Bofang, Z. (2018). *The Finite Element Method: Fundamentals and Applications in Civil, Hydraulic, Mechanical and Aeronautical Engineering.* Singapore: John Wiley & Sons Singapore Pte. Ltd.
DOI: <https://doi.org/10.1002/9781119107323> (in English)
13. Johnson, R. P. (2018). *Composite Structures of Steel and Concrete: Beams, Slabs, Columns and Frames for Buildings.* Wiley Blackwell. DOI: <https://doi.org/10.1002/9781119401353> (in English)
14. Kruhlikova, N. G., & Bannikov, D. O. (2019). Rational design of shot-span industrial building roof for reconstruction conditions. *Science and Transport Progress*, 2(80), 144-152.
DOI: <https://doi.org/10.15802/stp2019/165853> (in English)
15. Neduzha, L. O., & Shvets, A. O. (2018). Theoretical and experimental research of strength properties of spine beam of freight cars. *Science and Transport Progress*, 1(73), 131-147.
DOI: <https://doi.org/10.15802/stp2018/123457> (in English)
16. Shames, I. H. (2017). *Energy and Finite Element Methods In Structural Mechanics.* New York: Routledge.
DOI: <https://doi.org/10.1201/9780203757567> (in English)
17. Singiresu, S. R. (2018). *The Finite Element Method in Engineering: 6th Edition.* Elsevier Inc.
DOI: <https://doi.org/10.1016/c2016-0-01493-6> (in English)

Received: September 18, 2019

Accepted: January 20, 2020