



Ecogrid.dk Phase 1 WP4 report: New measures for integration of large scale renewable energy

Sørensen, Poul Ejnar; Togeby, Mikael; Ackermann, Thomas; Chandrashekhara, Divya K; Horstmann, Jørgen Peter Frederik; Jóhannsson, Hjörtur; Nielsen, Arne Hejde; Nyeng, Preben; Rasmussen, Tonny Wederberg; Xu, Zhao

Total number of authors:
21

Publication date:
2008

Document Version
Publisher's PDF, also known as Version of record

[Link back to DTU Orbit](#)

Citation (APA):
Sørensen, P. E., Togeby, M., Ackermann, T., Chandrashekhara, D. K., Horstmann, J. P. F., Jóhannsson, H., Nielsen, A. H., Nyeng, P., Rasmussen, T. W., Xu, Z., Østergaard, J., Madsen, H., Pinson, P., Poulsen, B., Poulsen, N. K., Cronin, T., Hansen, A. D., Jensen, S. G., Meibom, P., ... Nørgård, P. B. (2008). *Ecogrid.dk Phase 1 WP4 report: New measures for integration of large scale renewable energy*. Danmarks Tekniske Universitet, Risø Nationallaboratoriet for Bæredygtig Energi.

General rights

Copyright and moral rights for the publications made accessible in the public portal are retained by the authors and/or other copyright owners and it is a condition of accessing publications that users recognise and abide by the legal requirements associated with these rights.

- Users may download and print one copy of any publication from the public portal for the purpose of private study or research.
- You may not further distribute the material or use it for any profit-making activity or commercial gain
- You may freely distribute the URL identifying the publication in the public portal

If you believe that this document breaches copyright please contact us providing details, and we will remove access to the work immediately and investigate your claim.

EcoGrid^{dk}

www.ecogrid.dk



*Steps toward a Danish power system
with 50% wind energy*

EcoGrid.dk Phase 1

*WP4: New measures for integration of large
scale renewable energy*

*Funded by Energinet.dk PSO R&D-contract project
no. 2007-1-7816*

This project is funded by Energinet.dk via the PSO ForskEL program.

PSO ForskEL R&D-contract no. 2007-1-7816

Project responsible:

Teknologisk Institut
Kongsvang Allé 29
8000 Århus C.

(CVR.nr. 56976116)

Edited by:

Poul Sørensen, Risø DTU
Michael Togeby; EA Energy Analyses a/s
Thomas Ackermann; Energynautics GmbH

Contributions from several authors; see paragraph 1.3.1

Abstract (max. 2000 char.):

This report describes a survey of possible and likely new measures which can ensure a reliable and economic operation of the power system with large scale distributed generation mainly from renewable sources, particularly wind power. The measures are selected to ensure the necessary flexibility in the power system, and at the same time ensure a secure and reliable operation of the system.

The survey is done as a part of the Danish Ecogrid.dk project with a perspective of 50 % of the electricity consumption supplied from wind power, corresponding to the new energy policy of the Danish government. Still, the measures are general, in the sense that they can be used in other power systems than the Danish. This should also make the measures more attractive from a business point of view.

The interaction of the power system with other energy systems (heating and transportation) is considered where it is relevant for the electricity system.

Contents

Preface	5
1 Introduction	6
1.1 Scope	6
1.2 Key references	7
1.2.1 Danish technology catalogue	7
1.2.2 Energinet.dk system plan 2007	7
1.3 Survey method	7
1.3.1 Participants and organisation of work	7
1.3.2 Format	9
2 Conclusions	10
2.1 General findings and conclusions	10
2.2 Potential of new measures	10
2.2.1 Costs	11
2.2.2 Time scale	11
2.2.3 Positive and negative regulation	13
2.2.4 Volume	13
2.2.5 Maturity	14
2.2.6 Environmental issues	14
3 Power measures	15
3.1 Overview of Electrical Energy Storage Technologies	19
3.1.1 Compressed Air Energy Storage	22
3.1.2 Flywheel Energy Storage Systems	28
3.1.3 Vanadium flow battery	35
3.1.4 Lead acid battery	38
3.1.5 Li Ion battery	41
3.1.6 Sodium Sulfur (NaS) battery	43
3.1.7 ZnBr battery	45
3.1.8 Metal air battery	47
3.1.9 Regensys battery	49
3.2.1 HTPEM based micro CHP	51
3.2.2 SOFC based micro CHP	53
3.2.3 Alkaline Electrolyses based micro CHP	55
3.3 Generation replacing base load units	58
3.4 Overview of integration with district heating	61
3.4.1 Cooling Towers	69
3.4.2 Back Pressure to Condensing Mode	71
3.4.3 Heat Storage	74
3.4.4 Turbine Bypass	76
3.4.5 Electric Heating	78
3.4.6 Heat pumps	80
3.4.7 Heat Boilers	86
3.5 Overview of Integration with Transportation	88
3.5.1 Battery Electric Vehicles (BEV)	96
3.5.2 Plug-in Hybrid Electric Vehicles (PHEV)	101
3.5.3 Fuel cell Electric Vehicles (FCEV)	106

3.6 Overview of FACTS	111
4. Market measures	135
4.0 Overview of Current Nordic electricity market	139
4.1 Real time energy markets	151
4.2 Nodal Pricing	154
4.4.1 Trading arrangements with the continent	162
4.4.2 Market coupling and implicit_auctioning DK-GE	167
4.4.3 Full EU market coupling	173
4.5 Ancillary Services Market	177
4.6.1 DemandResponse – HourlyPrices	179
4.6.2 Demand Frequency Response (DFR)	183
4.6.3 Demand Response - Customer Equipment	187
5 Control / IT measures	192
5.1 Communication standards IEC 61850 and IEC 61400-25	195
5.2 Description of wide-area protections	201
5.3 Interactive Meters - Concept of Energy Flow Control	206
5.4 Overview of wind farm control	216
5.4.1 Active Power regulating functions	218
5.4.2 Reactive Power Control	222
5.4.3 Low Voltage Ride Through	227
5.4.4 Grid Synchronisation and Monitoring	230
5.4.5 Virtual inertia	234
5.4.6 Optimal production control	237
5.4.7 Overload capability	239
5.4.8 Black start support	241
5.4.9 Island operation support	243
5.4.10 HVDC connection	247
5.4.1 Wind Power Point Forecasting	251
5.5.2 WindPowerForecastUncertainty	255
5.5.3 LoadForecasting	259
5.6 Local Grid Support with Micro Production	262
5.7 PMUs	270
5.8 Real Time State Estimators	276
5.9 FaultPrediction-StabilityAssessment	278

Preface

This report describes results from work package 4 of the Ecogrid.dk project. The project was initiated and funded by the Danish TSO, Energinet.dk as PSO project no 2007-1-7816, and it was carried out in cooperation between the Technical University of Denmark (Elektro, IMM and Risø), Aalborg University (IET), ECON, Energynaut, EA Energianalyse, Paul-Frederik Bach, EC Power, Danfoss, DONG Energy, Vattenfall A/S, kk-electronic and Vestas

1 Introduction

1.1 Scope

The objective of this work has been to provide an overview of possible and likely new measures which can ensure a reliable and economic operation of the electricity power system with large scale generation from renewable sources, particularly wind power.

“Large scale generation from renewable sources” is a qualitative rather than a quantitative characterisation of the power system. Although the specific power system characteristics have not been decisive for the measure survey, the intension has been to select measures that are likely to be relevant to meet the needs corresponding to the new energy policy of the Danish government, i.e. a Danish power system with 50 % of the electricity consumption supplied from wind power by 2025. Still, it is important that the measures have an international perspective as well, at least on the long term. If this is not the case, then the measures are not likely to succeed for commercial reasons.

The required measures can roughly be grouped as illustrated in Figure 1. On one hand, the technologies are needed, but in order to support the technology development, enrolment and operation, the institutional framework also needs to be in place. Legislation and regulation issues, taxes and subsidies have not been investigated in the present survey, but new market functions and technologies have been included. The technologies have been divided into power technologies and control / IT technologies. Thus, the work has been performed as a survey of new measures, structured in a *catalogue* as power measures, market measures and control/IT measures.

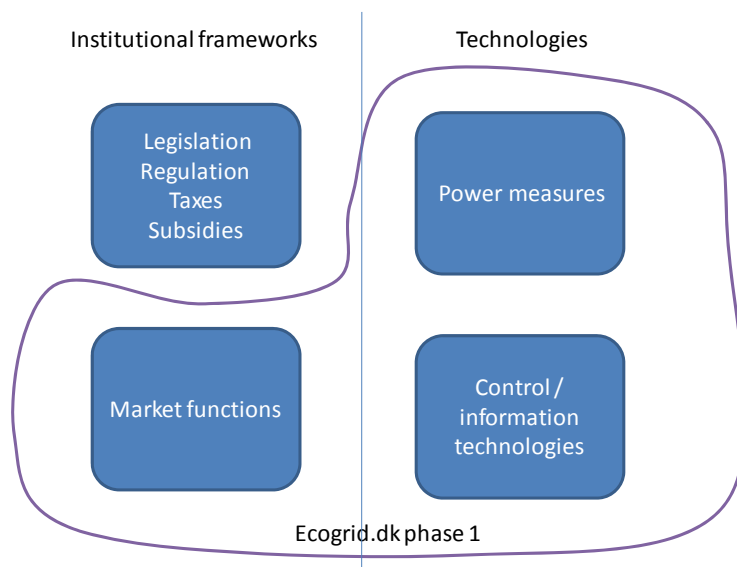

Figure 1. Mapping of measures included in the Ecogrid.dk survey.

A number of factors have influenced the selection of new measures for the catalogue. First of all, the measures should have the potential to provide characteristics that are needed by the system. Secondly, the selected measures have a promising (short or long term) business perspective.

The individual measures contribute directly or indirectly, either to the balancing of production with demand or to ensure the system security. The increased balancing energy and power capacity is needed by the system, simply to accommodate more variable and only partly predictable wind

power and other renewable sources. But new measures are also needed to ensure a continued high level of system security. This is an indirect consequence of increased renewable generation, because the renewable generation will replace conventional generation, which provides the ancillary services that are needed to ensure the system security in the present system.

The survey has involved a large number of partners, including industry (Vestas, kk-electronic, Danfoss and EC Power), energy companies (DONG Energy and Vattenfall), consultants/advisors (EA-energianalyse, ECON, Energynaut and Paul Frederik) and research groups (DTU CET, Risø DTU, DTU IMM and IET AAU).

1.2 Key references

1.2.1 Danish technology catalogue

In March 2005, the Danish Energy Authority, Elkraft System and Eltra issued “Technology Data for Electricity and Heat Generating Plants”, often referred to as the technology catalogue. This catalogue provides data for known types of power plants (incl. wind power), storage technologies and units for integration with heat systems.

The format chosen for the technology catalogue is a combination of qualitative descriptive text and quantitative data sheet with key technical figures for present (2004) and forecasts for 2010-15 and 2020-30 respectively. The same format has been applied for all technologies, which supports the comparability. Most of the quantitative figures are given for most of the technologies, but there are also quite a few missing figures.

1.2.2 Energinet.dk system plan 2007

Energinet.dk issues a system plan every year. The System Plan 2007 includes for the first time a description of “means to meet the challenges” of “A visionary Danish energy policy 2025”. The means are grouped in generation, transmission and consumption as follows:

Electricity generation side

- Regulation of wind turbine generation
- Geographical spread of offshore wind farms
- Mobilisation of reserves, regulating resources and new types of facilities.

Electricity transmission side

- Relocation of the grid connection point for offshore wind farms
- Increased grid transmission capacity, eg by using high-temperature conductors
- Reinforcement and expansion of the domestic grid.

Electricity consumption side

- Connection to the heating system (electric boilers and heat pumps)
- Electric cars and hybrid cars as demand response
- Additional demand response
- Electricity storage: Hydrogen, Compressed Air Energy Storage, battery.

1.3 Survey method

1.3.1 Participants and organisation of work

The survey of new measures done in WP4 of the Ecogrid.dk project phase 1 has been organised in 3 groups of measures: power measures, market measures and control/IT measures. The task has involved more than 30 persons from the 17 participants in the project. The following persons have contributed to the work package:

DTU Elektro (CET)

- Divya K Chandrashekhara
- Jørgen Peter Horstmann
- Hjörtur Jóhannsson
- Arne Hejde Nielsen
- Preben Nyeng
- Tonny Wederberg Rasmussen
- Zhao Xu
- Jacob Østergaard
- Morten Lind

DTU IMM

- Henrik Madsen
- Pierre Pinson
- Bjarne Poulsen
- Niels Kjølstad Poulsen

Risø DTU

- Tom Cronin
- Anca Hansen
- Stine Grenaa Jensen
- Peter Meibom
- Nina Juul
- Per Nørgaard
- Poul Sørensen

AAU (IET)

- Remus Teodorescu
- Birgitte Bak-Jensen
- Florin Iov
- Lasse Rosendahl
- Robert Weissbach (guest from Penn State University, USA)

ECON

- Berit Tennbakk
- Klaus Skytte
- Kristin Munthe

Energynaut

- Thomas Ackermann

EA Energianalyse

- Mikael Togeby
- Jesper Werling

Paul-Frederik Bach

EC Power

- Jens Otto Ravn Andersen

Danfoss

- Bruno Lund Pedersen
- Per Balslev
- Thomas Ritz Nissen

- Uffe Borup

DONG Energy

- Lars Bai Jensen
- Tommy Mølbak

Vattenfall

- Preben Jørgensen

kk-electronic

- Paul Bach Thøgersen

Vestas

- Philip Carne Kjær

1.3.2 Format

The first task of WP4 was to define a joint format to describe the measures, which has been a challenge because very different measures are included. The starting point has been the technology catalogue approach, but the joint quantitative description applied in the technology catalogue is meant for power measures, and makes little or no sense for the market and control/IT measures. Instead, only the qualitative description has been standardised, according to the following outline:

1. Technical description

- Brief description
- System interface (e.g. grid connection)
- Technical data
- Safety issues

2. Impact

- Benefits (and drawbacks) to power system
- Dependence on other measures
- Environmental impact

3. Business issues

- Costs
- Manufacturers
- Patents

4. Status

- Existing installations
- Potential development
- Research and development
- Bottlenecks

5. Other issues

6. References

In addition to the descriptions of individual measures in this format, a number of overview documents for comparable measures have been made.

2 Conclusions

2.1 General findings and conclusions

The survey confirms that there are many potential measures. But most of the measures will not develop unless incentives are provided. Market design can create important incentives, but in most cases subsidies will be needed to promote the development.

Generally, there are competing solutions to the implementation of most of the measures. Thus, there is an obvious risk of being frontrunner in choosing a solution that will not survive the competition. On the other hand, choosing a competitive solution and being frontrunner will give a lead that can open for new industrial adventures, which can be comparable or even further reaching than the wind power success.

An example of this is integration of the electric power system with transportation. Denmark has all opportunities to set the agenda, because several stake holders have chosen Denmark as demonstration and development platform. The industrial solutions stretch from bio fuels and fuel cells over hybrid vehicles (strand alone or plug in) to electric vehicles. And for electric vehicles, there are different competing options for extending the drive range beyond the 2-300 km that can be obtained with full batteries. Better Place believes in tank station with fast battery exchange, whereas SIEMENS believes in fast charging. The competing solutions require substantial investments, and only the future competition will show which one(s) will survive.

In this perspective, it is interesting to note that there is no single technology for grid connection of modern wind turbines, but rather a number of competing options for individual wind turbines (doubly-fed, full scale converter) and for wind plants (auxiliary equipment, AC/DC).

Another issue is that the industries may develop new and smart solutions, but they are not designed to meet the actual needs for flexibility in the future power systems. Again, electric vehicles are an example. If the battery charging is not performed in an intelligent way, then they will typically be charged in the peak load hours when the owners return from work. A simple diurnal tariff system could help this issue, but it would not support balancing of wind power forecast errors. Another example is household heat pumps, which are apparently not designed to operate flexible and thus be able to contribute to power balancing. It is crucial that the industry gets the understanding of the operational needs of the power system, so that the industry is able to include this in the development and optimisation of the new products. In order to enable the industry to do this, it is recommended that Energinet.dk develops technical specifications to the new products, based on studies of the needs in future power systems.

The conclusion of the above considerations is that it is not right and not possible to point out “the winning solutions”. What should be done is to provide the necessary infrastructure and incentives that will create an environment which will enable and encourage the stake holders to develop competitive measures. Moreover, initiatives must be taken to ensure that the needs for flexibility for the future power systems are understood and integrated correctly in the development of new solutions.

2.2 Potential of new measures

As pointed out above, there is no absolute or final key to categorise the selected new measures. Instead, a number of key issues are dealt with below. These are

- Costs

- Time scale
- Positive and/or negative regulation
- Volume
- Maturity
- Environmental impact

2.2.1 Costs

The potential cost of the individual measures is obviously decisive parameter for the business opportunities. Therefore, the costs have been a part of the survey. However, since many of the measures are not yet technically matured, and certainly not mass produced, there is a significant uncertainty in many of the cost estimates. Besides, there may be business models for the measures in the industry which has not been – and cannot be – made publically available.

Still, for some of the measures it has been possible to provide reliable and promising cost estimates. This has been the case concerning many of the options for integration with the heat sector, where cooling towers and dump loads are low investment cost solutions, with investment costs in the range of 0.06 – 0.16 k€ /kW. For comparison, investment costs of a large heat pump is in the range 0.6 – 1.5, and for Compressed Air Energy Storage (CAES) it is 0.5 k€ /kW, which is in the same order of magnitude as for a gas turbine.

Integration with transportation provides access to battery storage in the electric vehicles that is paid by the transportation need, but which can be utilised to provide more flexibility to the electric power system. Thus, the only additional costs associated with this measure is on communication and control.

In order to develop any of the new power measures, it is necessary to invest in the necessary communication and control. The costs for this have not been assessed, but it is obviously important to find cheap solutions because the flexibility is distributed on millions of costumers each with several components that can contribute.

2.2.2 Time scale

The power must be balanced on all time scales in order to ensure stable system operation and security of supply. The time scales are illustrated in Figure 2, pointing out different technical and market issues. Starting with the short time scales, the following are indicated:

- *Inertia* is a very important parameter for the power system stability, as it limits the rate of change of frequency, and thus ensures that the system can respond to the frequency changes before they become too big. Inertia is active in a few seconds, depending on the system size.
- *Droop frequency control*, which is often denoted primary frequency control, is the automatic frequency control provided today by central power plants that change generation depending on the frequency. The typical time scale is from a few seconds up to 10-30 seconds.
- *Intra hour balancing*. This is to limit the area control error, i.e. the deviations from scheduled exchange with AC connected neighbor. Eventually, this balance is a TSO responsibility.
- *Hour by hour*. Energy companies can trade balancing power to modify the day ahead scheduling.

- *Diurnal cycle.* Especially the demand varies in the diurnal cycle. Wind power diurnal variations are relatively small in Denmark, whereas PV obviously varies significantly in this time scale.
- *Day ahead scheduling* is close to the diurnal cycle, looking 36 hours ahead.
- *Weather systems.* The time scale of weather changes typically varies from days between front passages to several weeks with low wind due to stable high pressures.
- *Seasonal variations.* Load (electric and heat), wind power and PV varies significantly during a season
- *Year by year.* Wet and dry years are important for the ability to provide supply from Nordic hydro
- *Long term investments.* Investments in new transmission systems and new generation capacity are based on long term planning.

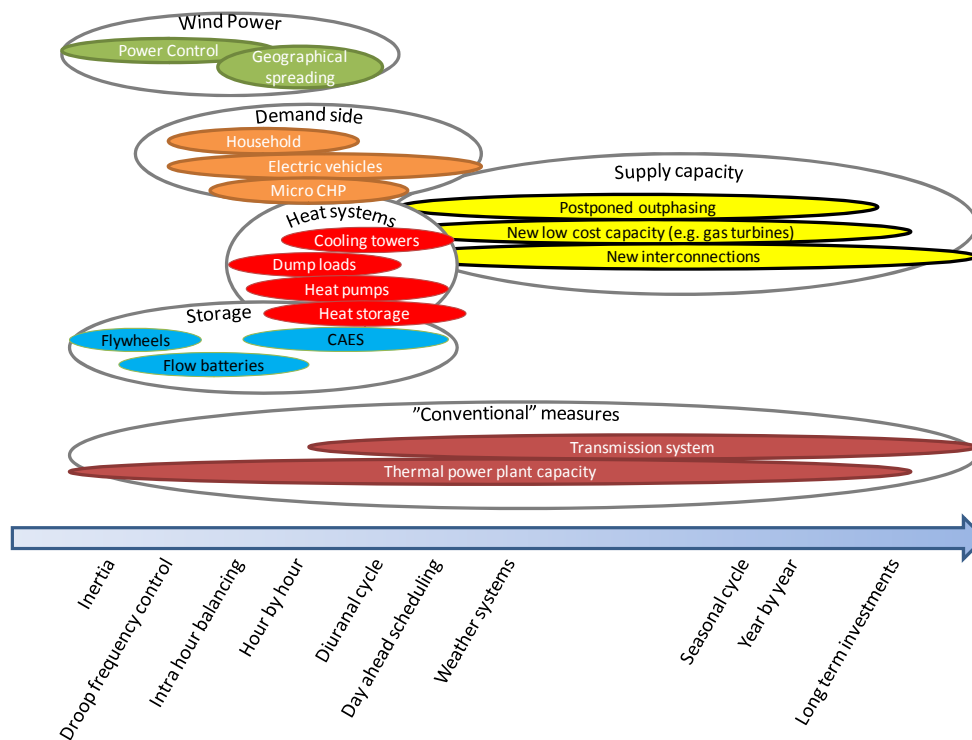

Figure 2. Mapping of measures on time scales.

The system security relies on the short time scales, directly on inertia and droop frequency control, and indirectly on an effective intra hour balancing which ensures that the frequency droop reserves are recovered as reserves shortly after they were activated. The balancing from hour by hour up to day ahead scheduling is organised by the markets. Long term investments are considered a very important issue, because the large scale wind power development will require investments in generation capacity which will be run at a very low load factor, and therefore it will be difficult to pay back the investment.

The new measures on demand side, integration with heat and transport, and storage options will only work on limited time scales. The exact time scales cannot be specified, also because it depends on season and weather. Still, on the storage side, heat system integration and Compressed Air Energy Storage (CAES) can obviously work on a longer time scale than flywheels.

In this perspective, it is still a challenge to ensure that there is investment in sufficient capacity to provide the power supply also in long periods, e.g. weeks with stable high pressure and very low wind speeds. A part of this capacity can be provided on a national basis, either by postponing the outphasing of existing thermal units or by investment in low cost engines or using emergency backup units. Another part can be provided by improved interconnections, mainly to hydro power in Norway, but this also requires that the hydro generation capacity in Norway is increased.

2.2.3 Positive and negative regulation

Up- and down regulation is traditionally used to characterise regulating capacity of power plants, assuming that only the generation side is regulated and thus generation follows the load variations. With new flexibility on the demand side, this concept becomes rather awkward, because the balancing effect of down regulating demand is the same as of up regulating supply. In order to overcome this, we will use “positive regulation” to describe up regulation of supply and down regulation of demand on one side, “negative regulation” to describe down regulation of supply and up regulation of demand on the other side.

Table 1 shows positive and negative regulation for a number of important power measures.

Table 1. positive and negative regulation capability of different measures

Measure	Positive	Negative
Integration with heat system		
• Cooling tower	√	
• Mode shift (back pressure to condensing)	√	
• Heat consumption flexibility	√	√
• Heat storage	√	√
• Interconnected heat system with multiple CHPs	√	√
• Turbine bypass		√
• Dump loads / electric heating		√
• Large heat pumps		√
• Boilers		√
• Local CHPs		√
Integration with transport system	(√)	√
Other demand side options	√	√
Storage	√	√
Wind power control	(√)	√
New generation units	√	√
New interconnections	√	√

2.2.4 Volume

The need for new measures has not been quantified as volumes. In order to do that, it would be necessary to perform system studies for the different scenarios. Instead, it has been part of the task

of the survey to quantify the potential volume of the individual measures. This has not been possible for all measures, but below, some of the most important findings are mentioned:

- In 2004 Elkraft System estimated that the power plants in the Copenhagen district heating area have a potential of releasing up to 200 MW of electricity production capacity using mode shifting on cold days.
- In total there is 1551 MW decentralised CHP plants in Denmark (2006). With a cm value of approximately 0.7 and 10 hours of storage capacity this corresponds to approximately 22 GWh of heat storage.
- Turbine bypass (decrease electricity and increase heat production) will be possible on base load plant blocks with extraction units, which is the case for a total capacity of 1600 MW.
- It was estimated that 10 % of the passenger car fleet in 2025 could be Plug-in Hybrid Electric Vehicles (PHEV)'s and battery Electric Vehicles (BEV)'s. This corresponds to a total number of about 200.000 EDV's in 2025.

2.2.5 Maturity

The mentioned measures for integration with heat system are mature. For instance, the heat storage and boiler technology is very well developed. However, more work can be done in developing systems to fully take advantage of the flexibility offered by using the combination of a CHP plants, a heat boiler and a heat storage to produce electricity and heat.

Electric vehicles are in an earlier development phase, but this is mainly with respect to optimising the concepts and production to a large scale.

2.2.6 Environmental issues

The heat system integration measures are highly dependent on different system aspects of the heat and electricity system (other production units, electricity and district heating networks, consumption patterns of electricity and heat). In order to assess the potential impact, the environmental consequences and the socio economic costs and benefits, coherent analysis of the electricity and district heating systems needs to be undertaken.

Most of the other measures have very little direct environmental impact.

3. Power Measures

The main conclusions concerning the power measures are:

Concerning power balancing

- On short term, integration with the heat power systems provides the most promising and mature measures, from a technical as well as economic point of view.
- On short to medium term, demand response can offer an important source of flexibility.
- On a medium term perspective, integration with the transport sector offers promising measures.
- On short to long term perspective, micro CHP can become important
- On a long term perspective, electricity storage may become relevant.
- Since the above measures work on a time scale up to maximum a couple of days, backup capacity is needed provide power in long periods without wind. This capacity can be provided by thermal generation and/or interconnections to available capacities in neighboring countries.

Concerning security / ancillary services:

- In order to reduce the need for online central generation capacity, it is necessary to provide future system services from the following sources:
 - Local CHPs
 - Wind power plants
 - FACTS

The activation of power balancing from the new measures and of system services from new sources depend on market and control/IT measures.

Storage

Detailed descriptions have been made of the following storage technologies:

- Compressed Air Energy Storage (CAES)
- Flywheel
- Vanadium flow battery

Besides, draft descriptions are made for lead acid, lithium ion, sodium sulfur, zink bromine and metal air batteries, and for regenerative fuel cells.

For electrical energy storage, the relationship between power capacity and energy volume is essential. Figure 1 illustrates this for selected types of energy storage. Typical power ratings are given as the x-axis, while the energy volume is indicated by the time to completely fill and / or empty the unit, i.e. kWh/kW. For flow batteries, the energy volume and thus the time can be designed independently on the power capacity, but for economic reasons, the typical time is limited to maximum one day.

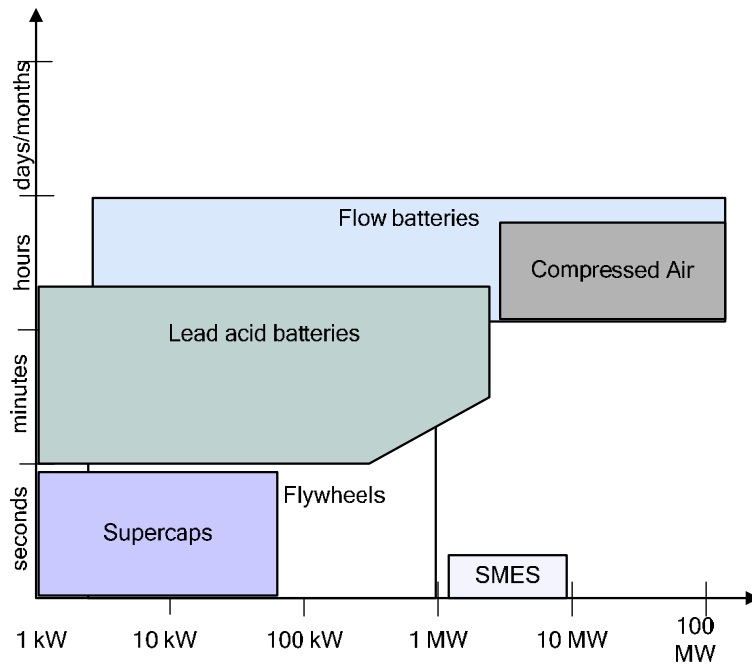

Figure 1. Typical power capacities and energy volumes (given as fill or empty times) for selected storage technologies

Micro generation

This task covers microCHP units, which are both fuel cell based units (typically domestic, single household) and units with combustion engines (slightly larger units for apartment houses or small factories). Descriptions are available for the following concepts:

- High Temperature Proton Exchange Membrane (HT-PEM) fuel cells
- Solid Oxide Fuel Cells (SOFC)

A demonstration project involving 100 fuel cell based units is planned, while the units based on combustion engines are more mature and are commercially with increasing sales in UK. The feasibility of these units depends on the necessary market and communication infrastructures to take advantage of the intelligent design and control.

Base load generation

The future thermal units will have to operate with significantly less load factors than the present thermal units, but at the same time the capacity of such units will still be necessary in periods with low wind speed. Preferably, the new units should be characterised by a high flexibility enabling them the balance wind power fluctuations, but since most of the other measures investigated in the Ecogrid.dk project support balancing on a limited time scale (max one day), the main issue of the thermal units will be to provide capacity in longer periods with low wind speeds. For these reasons, the challenge can be more on the business side (to ensure that the capacity is available) than on the technical side (that the capacity is fast to control).

The capacity can be provided either by investment in new units or by delay of the commissioning of existing plants. Finally the need for capacity could be reduced (but probably not removed) by stronger interconnections to neighbouring countries with available capacity (Nordic hydro power capacity, provided that there is still available capacity, and taking into account new

interconnections from Nordic neighbours to the continent and taking into account the wind power development in the Nordic countries)

Integration with heat energy systems

A number of technical measures exist in order to make the production on CHP plants more flexible:

- Cooling towers on back pressure units
- Turbine bypass
- On extraction units: Shift from back pressure to condensing mode => higher electricity production
- More flexible consumption of heat (technological options and consumer behaviour)
- Heat storage (diurnal and seasonal)

Furthermore other heat production technologies can help improve the flexibility of the CHP plants:

- Electric heating (dump loads)
- Large heat pumps
- Heat boilers
- Other CHP units in an interconnected district heating system

More detailed descriptions are available for most of these measures.

The impact of the different measures is shown in table below.

Measure	Can reduce electricity production	Can increase electricity production
Cooling towers (Back pressure units)		X
Shift from back pressure mode to condensing mode		X
More flexible consumption of heat	X	X
Heat storage	X	X
Other CHP units in interconnected heat system	X	X
Turbine bypass	X	
Electric heating (dump loads)	X	
Large heat pumps	X	
Boilers	X	

Table 1: Impact of different measures in the district heating system.

Integration with transportation

Integration with transportation is described in a separate document, supplemented by individual measure descriptions for

- Battery Electric Vehicles (BEV)
- Plug-in Hybrid Electric Vehicles (PHEV)
- Fuel Cell Electric Vehicles (FCEV)

The integration with transportation has a significant potential: If PHEV's and BEV's are introduced on the market in 2010 – 2012 and in real mass production in 2015 it is a realistic – and optimistic – estimate that 10 % of the passenger car fleet in 2025 could be PHEV's and BEV's. This corresponds to a total number of about 200.000 EDV's in 2025. As an illustrative example this car fleet could be powered by 200 MW wind power capacity and store the average night production from 1.200 MW wind power.

New components

A document describing Flexible AC Transmission System (FACTS) has been made. It includes

- HVDC VSC
- HVDC line commutated
- SVC
- STATCOM

Other relevant components can be synchronous condensers.

3.1 Overview of Electrical Energy Storage Technologies

A number of mature and emerging technologies may be viable for electrical energy storage use. Each has benefits and drawbacks in terms of energy storage capacity, peak power capability, and response time among other variables. Therefore, each technology will be most viable for a particular energy storage application, such as peak load shaving, transient voltage control, and operation as an uninterruptible power supply.

Among the technologies available for electrical energy storage, the relationship between peak power and energy is critical. Figure 1 shows the types of energy storage devices available, and their location on a plot of time (i.e., Energy Storage) vs Power.

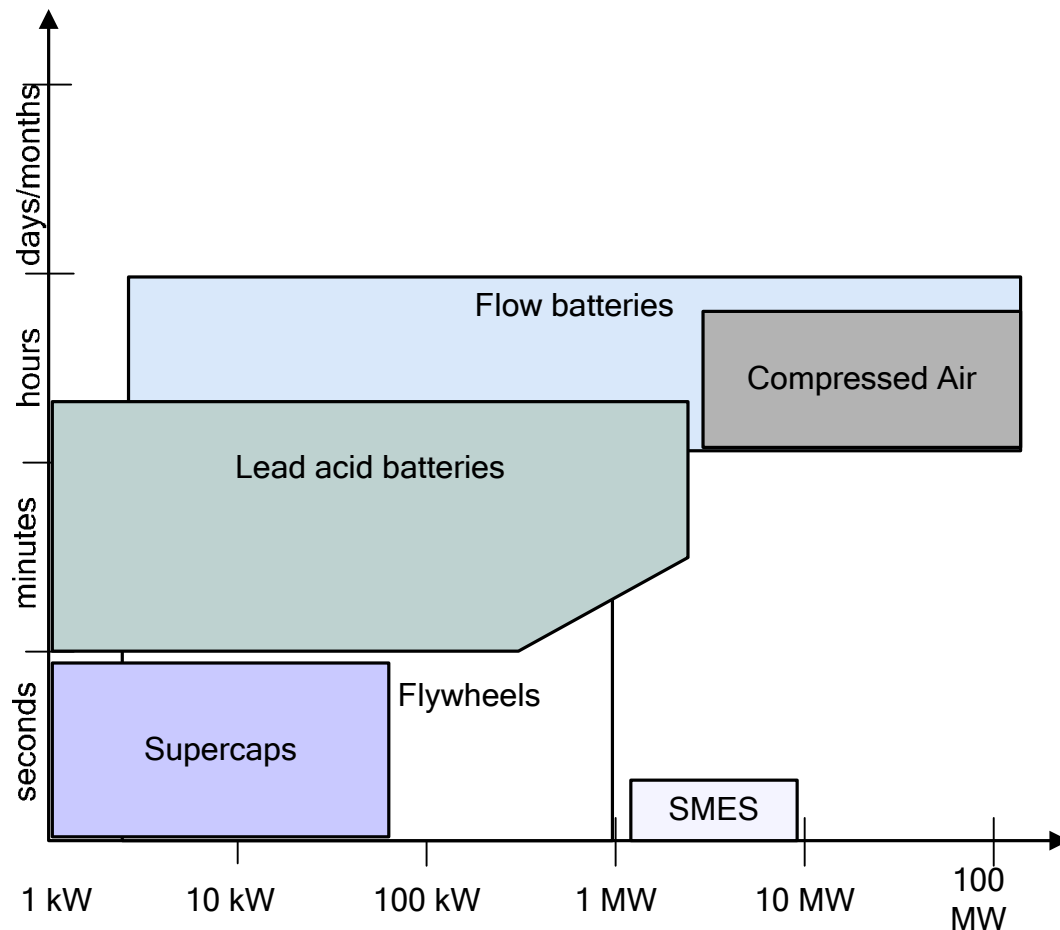

Figure 1. Available Technologies for Electrical Energy Storage

Short Comparison of Different Energy Storage Technologies

Energy Storage Technology	Power Capacity (MW)	Energy Capacity (kWh)	Electrical Efficiency (%)	Energy Cost (€/kWh/yr) ^A	Power Cost (€/kW/yr) ^A
Flywheel	<1.0	< 250	80+	77	0.88
Compressed Air	5 - 400	2600.000+	55-75	1.5-3 ^F	34.16
Conventional Battery	4 [1]	40.000 [1]	75-85 [8]	24-117 ^B	73-351 ^C
Redox Flow Battery	0.005 - 500 [1]	400.000 [1]	65 - 75 [3]	9.4-12.5 ^D	70-144 ^D
Superconducting Magnetic Energy Storage (SMES)	2 [1]	< 5 [1]	95 [4]	3x10 ⁵	47
Supercapacitors	< 20 [1] ^E	< 5 [1] ^E	85-98 [1, 5]	570	4.8
Hydrogen	0.2 - 4	N/A	75 - 80	6.8	128

Notes:

- A. Energy and Power costs are from [2], except for compressed air energy storage (CAES), where financial information is from [6] for a 300MW system (2004) that conservatively lasts 30 years [7]. In the case of CAES, the power cost per year is found by discounting the capital costs at an annual rate of 5%, similar to what the authors indicate in [2]. Yearly fixed O&M costs (11 €/kW/yr) are then added to the annualized power cost.
- B. Ranges for energy cost per year, from [2]:
 - a. Nickel Metal Hydride – 24
 - b. Sodium Sulphur – 34
 - c. Lead Acid – 55
 - d. Zinc Bromide – 79
 - e. Nickel Cadmium - 117
- C. Ranges for power cost per year, from [2]:
 - a. Nickel Metal Hydride – 96
 - b. Sodium Sulphur – 132
 - c. Lead Acid – 73
 - d. Zinc Bromide – 158
 - e. Nickel Cadmium - 351
- D. The lower range of the power and energy costs belongs to Regenesys redox flow batteries, while the higher range belongs to Vanadium redox flow batteries [2].
- E. Supercapacitor data is in kW/kg and Wh/kg for power and energy capacity, respectively.
- F. The CAES energy cost is estimated as a variable cost in €/MWh that is similar to that of single or combined cycle gas turbines [6, 7].

Summary

The electrical energy storage technologies available provide the utility with a number of options in providing stable operation of the grid, maximizing efficiency, ensuring power quality, and minimizing the effects of unplanned outages. As the various technologies improve further, the role of electrical energy storage will become even more critical in future power grid designs.

The most promising storage technologies are:

- Long term storage (peak-shaving) – CAES, Flow Batteries
- Short term storage (power quality, UPS, local voltage control) – Flywheels, Batteries, Supercapacitors, SMES, Hydrogen.

References

- [1] Advanced Power Converter for Universal and Flexible Power Management in Future Electricity Networks, UNIFLEX-PM, Contract no. 019794
- [2] Barton, J.P.; Infield, D.G., "Energy storage and its use with intermittent renewable energy," *Energy Conversion, IEEE Transaction on* , vol.19, no.2, pp. 441-448, June 2004
- [3] L. Barote, R. Weissbach, R. Teodorescu, C. Marinescu and M. Cirstea, "Stand-Alone Wind System with Vanadium Redox Battery Energy Storage", to be presented at the 11th International Conference on Optimization of Electrical and Electronic Equipment (OPTIM) 2008, May 2008
- [4] Hassenzahl, et. al., "Electric Power Applications of Superconductivity", *Proceedings of the IEEE*, Vol. 92, No. 10, Oct 2004
- [5] A. Green and C. Jehoulet, "The Non-Battery Battery – The Potential Role of Supercapacitors in Standby Power Applications", <http://www.battcon.com/PapersFinal2002/GreenPaper2002.pdf>
- [6] Danish Energy Authority, Technology Data for Electricity and Heat Generating Plants, March 2005
- [7] Derk J. Swider, "Compressed Air Energy Storage in an Electricity System With Significant Wind Power Generation," *Energy Conversion, IEEE Transaction on* , vol.22, no.1, pp.95-102, March 2007
- [8] http://wiki.xtronics.com/index.php/Sealed_Lead_Acid_Battery_Applications

Contact(s)

Remus Teodorescu, ret@iet.aau.dk.

Robert S. Weissbach, rsw7@psu.edu.

3.1.1 Compressed Air Energy Storage Systems

Technical description

Brief description

Compressed Air Energy Storage Systems (CAES) store electrical energy in the form of compressed air. The compressed air is usually stored in a cavern or other geological underground structure that enables a significant amount of energy storage. The basic concept of a CAES system is provided in Figure 1.

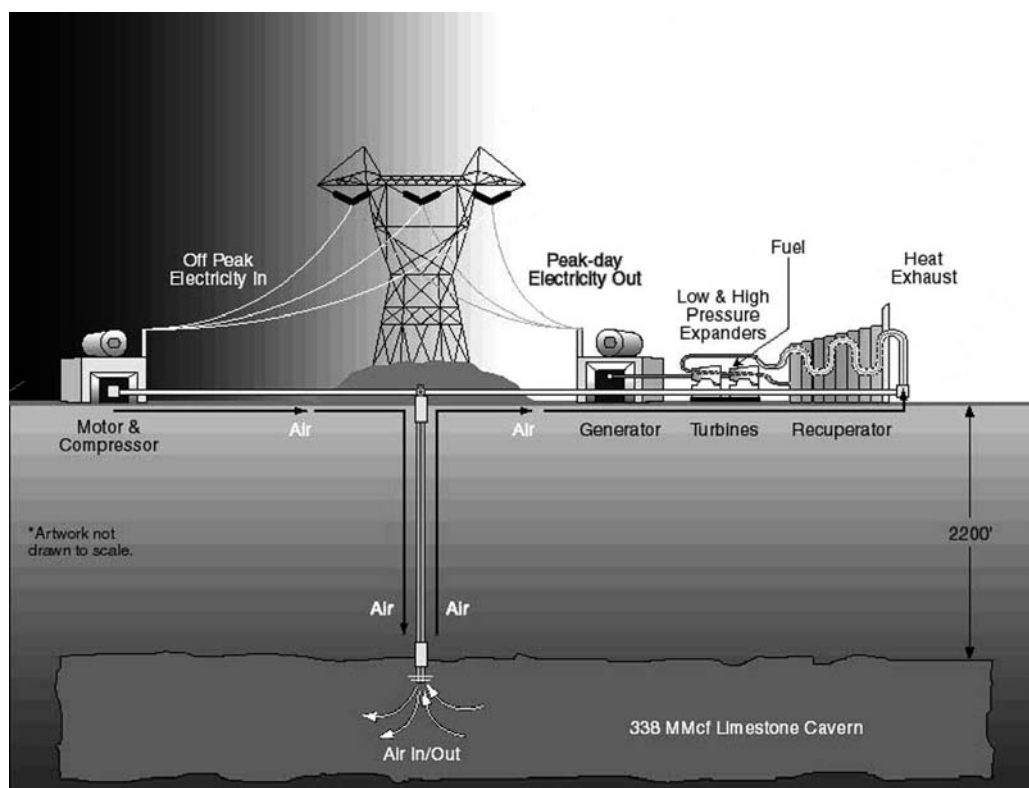

Figure 1. Compressed Air Energy Storage System [1]

Off-peak electricity is used to power a motor/generator that drives compressors to force air into an underground storage reservoir. This process typically occurs when utility system demands and electricity costs are the lowest. When electric power demand peaks during the day, the process is reversed. The compressed air is returned to the surface, heated by natural gas in combustors and run through high-pressure and low-pressure expanders to power the motor/generator to produce electricity [2]. The waste heat exhaust could potentially be used for heating facilities or homes. A block diagram of the process is provided in Figure 2.

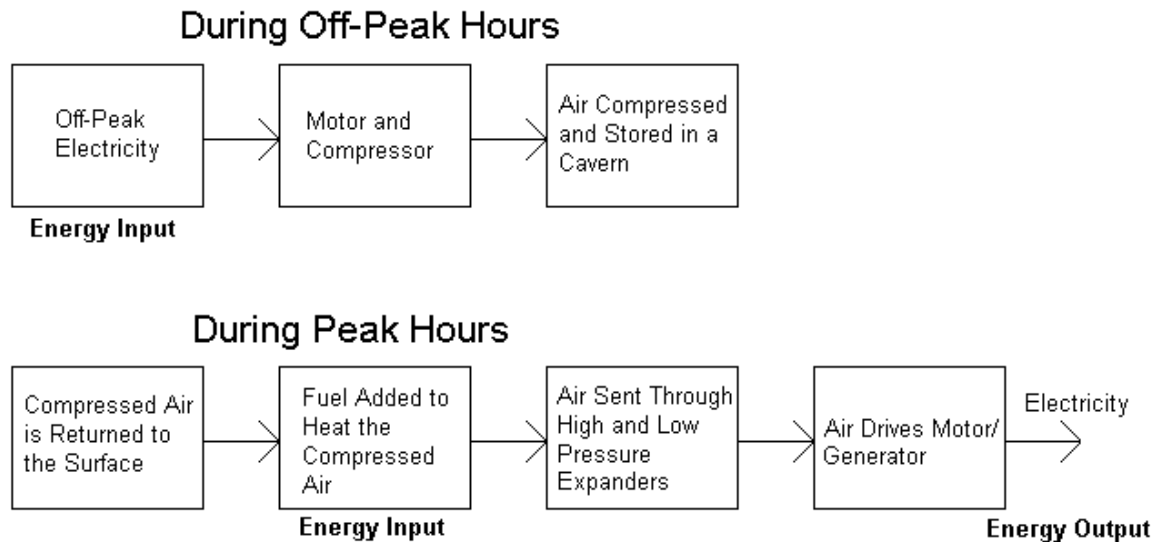

Figure 2. Block Diagram of the CAES Process

According to [14], 1Mm^3 of volume capacity is required for a 200MW plant. In [15], the carbon dioxide (CO_2) storage capacity of major aquifer structures in Denmark is provided, with sizes ranging from 0.2 to 43.6Mm^3 . For a given aquifer, the article assumes that 40% of the volume could in fact be used for CO_2 storage.

There are currently two operational CAES systems [1]:

- Huntorf, Germany has a 290MW plant that is capable of 600MWh of energy storage, commissioned in 1978.
- McIntosh, Alabama, USA has a 110MW plant that is capable of 2860MWh [3], commissioned in 1991. This plant cost \$65M to construct [7].

Other sites are in various stages of research and development, including one in Iowa, USA, that would integrate CAES with a wind farm [4]

Technical data

A technical summary of the technology is provided in Table 1. McIntosh data is used in lieu of Huntorf data in some cases because the system was completed more recently. Ramp up rate is calculated by assuming 8 hours to charge up the McIntosh plant from nil capacity to full capacity. Ramp down rate is from [3], where the author indicates that the McIntosh system can supply 110MW for 26 hours.

Table 1. Technical Parameters

Measure	Value	Reference
Power Capacity (MW)	110+	[1]
Energy Capacity (kWh)	2,600,000+	[18]
Voltage Range (kV)	Variable	
Electrical Efficiency (%)	75, 55, 66	[6], [10], [17]
Total Efficiency (%)	20	[16]
Availability (%)	95	[10]
Technical Lifetime (yrs)	20, 30, 45	[6], [10], [17]
Construction Time (yrs)	2.5 (McIntosh)	[7]
Automatic Frequency Control (is/could be/not feasible)	Could be	
Remote Setpoint Control (is/could be/not feasible)	N/A	
Tariff Control (is/could be/not feasible)	N/A	
Startup Time	12 minutes	[1]
Ramp rate up (generation) (%/min)	0.208 (McIntosh)	[3]
Ramp rate down (consumption) (%/min)	0.064 (McIntosh)	[3]
Reactive power regulation capacity (%)	N/A	
Minimum voltage (% in 100ms)	N/A	
Minimum load (% of capacity)	N/A	
Short circuit power (kVA/kW installed)	N/A	
Inertia time constant (sec)	N/A	
Black start support (is/could be/not feasible)	Is	[8]
Intentional islanding operation (is/could be/not feasible)	Could be	

Safety Issues

None with this mature technology. Maybe if the cavern fails holding the compressed air?

Impact

Benefits and drawbacks to power system

Benefits of CAES

- The energy storage capability of CAES rivals that of pumped hydro, making it one of the few energy storage options for peak power shaving
- High storage efficiency

- Relatively faster start up times than conventional combustion turbines (approximately 12 minutes)
- Lower greenhouse gas emissions than in conventional natural gas plants

Drawbacks of CAES

- The principal drawback of the technology is the reliance on a geological structure that can hold the compressed air. Sans that, the cost of such a system becomes prohibitive

Dependence on other measures

The size of the system is dependent on the availability of a storage cavern to hold the compressed air. The storage size of the cavern at the Huntorf site, as an example, is 300,000m³.

Environmental Issues

There are no significant environmental issues associated with this technology. Fuel consumption is comparatively less than for conventional natural gas plants. The need for appropriate storage of the compressed air can be an issue depending on the geology of the surrounding terrain.

Business Issues

Costs

The technology is considered mature [6]. See Table 2 for a business summary. The investment cost assumes a conversion rate of \$1.45/€. Based on the aquifer volume provided in [15] (assuming only 40% is actually usable), and the power capacity per volume provided in [14], a capacity of 5.288 x 10⁶ MW is potentially available. About 2/3 of the capacity is located in the Skagerrak formation near Thisted.

Table 2. Business Parameters

Measure	Value	Reference
Specific Investment (k€/kW)	0.41 (McIntosh) 0.5	[7], [14]
Fixed O&M (% of installed cost)	3.06	[10]
Capacity (potential) in Denmark (MW)	5.288 x 10 ⁶	[14], [15]
Capacity (potential) in World (MW)	N/A	

Reference [14] above is an average of two referenced costs (see page 126), and assumes \$1.45/€.

Manufacturers

CAES Development Company, LLC [9]
Renewable Energy Technologies [10]

Asea Brown Boveri [11] (constructed the Huntorf plant)
Dresser Rand [11] (constructed the McIntosh plant)
PB Energy Storage Services [13]

Status

Existing Installations

McIntosh, Alabama, USA, 110MW capacity
Huntorf, Germany, 290MW capacity

Research and Development

A literature search has been performed to identify new developments in the area of CAES. In [5], the authors provide a brief literature review of CAES, and focus on its use in conjunction with intermittent wind energy production. The authors in [6] look at CAES for demand side management (DSM), and include efficiency data on the technology. They focus on human-made storage sites.

Various sites are being pursued in Ohio (USA) [4], USSR [6], Italy [1], Japan [12] and Israel [1], among others. The Italian site is a small research facility.

Bottlenecks usually revolve around the availability of appropriate caverns or other storage facilities for the compressed air. Currently, man-made storage is prohibitively expensive.

Other issues

None.

References

- [1] <http://www.sandia.gov/media/NewsRel/NR2001/norton.htm>
- [2] http://www.eere.energy.gov/de/compressed_air.html
- [3] D. Mack, "Something New in Power Technology", *IEEE Potentials*, Volume 12, Issue 2, Page(s):40 – 42, Apr 1993
- [4] http://www.eere.energy.gov/state_energy_program/project_brief_detail.cfm/pb_id=1099
- [5] D. Swider, "Compressed Air Energy Storage in an Electricity System With Significant Wind Power Generation," *IEEE Transactions on Energy Conversion*, Vol. 22, No. 1, pp. 95-102, March 2007
- [6] Lee, S.-S., Y.-M. Kim, et al. (2007). Compressed Air Energy Storage Units for Power Generation and DSM in Korea. Power Engineering Society General Meeting, 2007. IEEE.
- [7] http://www.electricitystorage.org/tech/technologies_technologies_caes.htm
- [8] http://www.sandia.gov/ess/Publications/Conferences/2005/Jewitt_Mini-CAES.pdf
- [9] <http://www.hvllc.com/en/cms/?163>

- [10] Danish Energy Authority, Technology Data for Electricity and Heat Generating Plants, March 2005
- [11] http://www.seco.cpa.state.tx.us/zzz_re/re_wind_projects-compressed2005.pdf
- [12] http://www.energymanagertraining.com/power_plants/Energy_typs.htm
- [13] <http://www.pbenergy.com/>
- [14] A. Cavallo, "Controllable and affordable utility-scale electricity from intermittent wind resources and compressed air energy storage (CAES)," *Energy* 32 (2007) 120–127, Elsevier
http://www.precaution.org/lib/compressed_air_underground_storage.070201.pdf
- [15] Niels Peter Christensen and Michael Larsen, "Assessing the European potential for geological storage of CO₂ : the GESTCO project," *Geological Survey of Denmark and Greenland Bulletin #4, Review of Survey activities 2003*, pp. 13-16, http://www.geus.dk/publications/bull/nr4/nr4_p13-16-uk.htm
- [16] http://www.cogeneration.net/compressed_air_energy_storage.htm
- [17] Derk J. Swider, "Compressed Air Energy Storage in an Electricity System With Significant Wind Power Generation," *Energy Conversion, IEEE Transaction on*, vol.22, no.1, pp.95-102, March 2007
- [18] <http://www.energystoragecouncil.org/Septimus%20van%20der%20Linden%20OESC%20presentation.pdf>

Contact(s)

Remus Teodorescu, ret@iet.aau.dk.

Robert S. Weissbach, rsw7@psu.edu.

3.1.2 Flywheel Energy Storage Systems

Technical description

Brief description

A flywheel energy storage system (FESS) can be used to store electrical energy in the form of rotating mechanical energy. It is usually configured into a cylinder or disk. When electrical power is available, it can be used to spin up the flywheel to a rated mechanical speed. This rated speed is mostly a function of the material used to make the flywheel. Such a material must be able to withstand the centripetal forces generated when spinning.

The origins of the flywheel for energy storage can be found in a potter's wheel, where a flywheel is kicked and then continues to spin while the potter creates a piece of pottery. Modern versions of flywheel systems include the following features:

- **A carbon-graphite composite material.** This material is able to withstand much higher tip speeds than, for example, steel wheels. This is important because the governing equation for the energy storage of an FESS is:

$$E = \frac{1}{2} I \omega^2$$

Where:

E = the amount of energy stored in the flywheel

I = the moment of inertia of the flywheel, and is a function of the mass

ω = the angular velocity of the flywheel

Thus, doubling the moment of inertia of the flywheel will double the amount of energy stored. However, doubling the speed of the flywheel will quadruple the amount of energy stored.

- **A motor/generator.** The motor/generator converts electrical energy to mechanical energy, and vice-versa. When electrical energy is available to spin up the flywheel, the motor/generator acts as a motor. When electrical energy is removed, the motor/generator acts as a generator. It is possible to have the motor and generator be separate units within the FESS. The motor/generator must be able to handle the same rotational speed as the flywheel.
- **A power electronics conversion system.** The power electronics enable electrical power to spin up, and maintain, the flywheel to its rated rotational speed. When electrical power is removed or modified, the power electronics enable efficient conversion of the mechanical energy in the flywheel to electrical energy to maintain high quality and consistent power to the electrical loads that require such power.
- **A magnetic bearing system.** Magnetic bearings reduce the friction losses associated with the FESS by actively suspending the flywheel in air.
- **A vacuum system.** A vacuum system reduces the windage losses associated with the FESS.
- **A containment vessel.** A containment vessel is required in the event the FESS has a failure.

To reduce the cost of an FESS, lower cost flywheel materials, capable of lower speeds but potentially larger masses, are used. In lieu of magnetic bearings, a passive magnetic bearing system may be used. A portion of the flywheel's weight is

3.1.2 Flywheel Energy Storage System

suspended using magnetic bearings, with the remainder of the weight in contact with roller (or similar) bearings. Such a lower cost system may not use a vacuum. Historically, system integration of the advanced technologies listed above has been an issue.

A typical application of an FESS, used as an uninterruptible power supply (UPS) to protect the power supplied to a critical load, is shown in Figure 1. The power electronic converter is used to provide energy to “charge” the flywheel (via the coupled motor/generator) to its rated speed when electrical energy from the power grid is available. When grid power is removed, mechanical energy from the flywheel is converted back to electrical energy using the motor/generator. The power electronic converter ensures that the voltage and frequency to the sensitive load are the same as what the grid would provide.

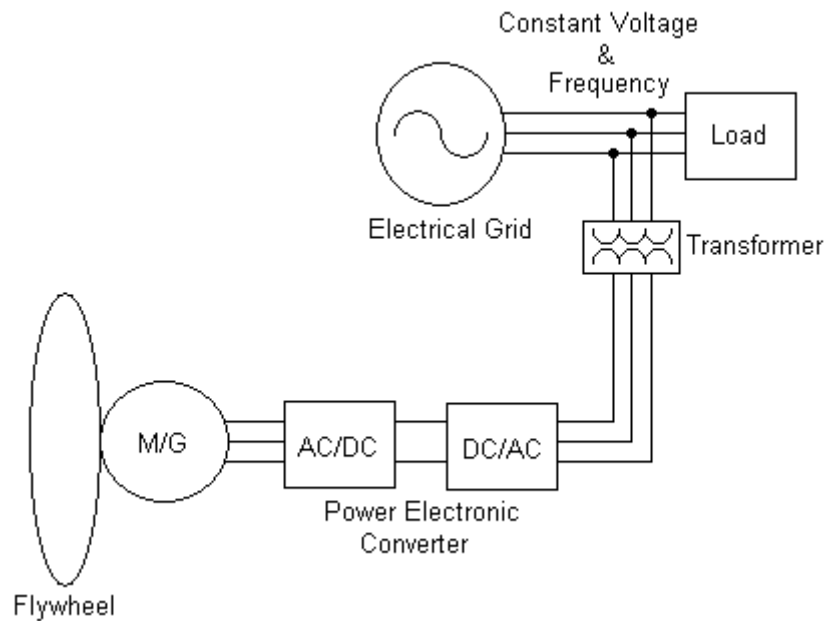

Figure 1. Typical UPS Application of a Flywheel Energy Storage System

Technical data

A technical summary of the potential Beacon system [1] (see below) is provided in Table 1.

Table 1. Technical Parameters

Measure	Value	Reference
Power Capacity (MW)	1.0	[2]
Energy Capacity (kWh)	250	[2]
Voltage Range (kV)	0.48	[2]
Electrical Efficiency (%)		
Total Efficiency (%)	80+	[17]
Availability (%)		
Technical Lifetime (yrs)	20	[2]
Construction Time (yrs)	?	
Automatic Frequency Control (is/could be/not feasible)	Could be	
Remote Setpoint Control (is/could be/not feasible)	Is	
Tariff Control (is/could be/not feasible)	N/A	
Startup Time	Fast	[18]
Ramp rate up (generation) (%/min)	N/A	
Ramp rate down (consumption) (%/min)	N/A	
Reactive power regulation capacity (%)	N/A	
Minimum voltage (% in 100ms)	N/A	
Minimum load (% of capacity)	N/A	
Short circuit power (kVA/kW installed)	N/A	
Inertia time constant (sec)	N/A	
Black start support (is/could be/not feasible)	N/A	
Intentional islanding operation (is/could be/not feasible)	Could be	

Safety Issues

The principal safety issue with the FESS is the possibility of a failure due to overspeed or some other factor. A containment system is included as part of the design of the FESS. Additionally, for terrestrial applications the FESS can be placed underground if necessary.

Impact

Benefits and drawbacks to power system

Benefits of the FESS

The FESS has a number of advantages over chemical storage batteries. These include:

- higher power density
- comparably fast response times (a function of the power electronics and controls)
- longer life, including more charge/discharge cycles
- easier to measure the state of charge (simply measure the rotational speed)
- no hazardous chemicals for waste disposal
- potentially low maintenance
- the ability to work in harsher environmental conditions
- faster recharge time

Drawbacks of the FESS

Compared to chemical storage batteries, the FESS has a number of disadvantages. These include:

- lower energy storage in the existing technology
- higher initial cost per kWh
- higher losses (due to friction and windage) in “float” mode, especially in lower technology systems

Dependence on Other Measures

As a means of providing ride-through capability, the FESS is not dependent on any other measures.

Environmental Issues

There are no significant environmental issues associated with this technology.

Business Issues

Costs

The technology is reasonably mature for UPS and ride-through applications. The technology is not mature for the implementation of systems well above 25kWh of energy storage, although the Beacon Power system described below shows promise.

Status

Existing Installations

Some example systems that are currently being advertised and employed include:

- Beacon Power – The “Smart Energy 25” is capable of 25kWh of energy storage [1]. Applications include:
 - Remote back-up power
 - Battery-free central office power
 - Peak shaving
 - Bridge to generator start
 - Load following

They also advertise a “Smart Energy Matrix” capable of 1MW of power, with 250kWh of energy storage [2]. It consists of a bank of 10 FESS modules connected in series/parallel. They are currently testing a frequency regulation system with the California Energy Commission [3]. However, such a system is still in development, as indicated in their 2006 annual report [4].

- Vycon – The “Direct Connect VDC 140” is capable of providing 140kW for 15 seconds of ride-through (approximately 0.5kWh) [5]. It has a maximum speed of 24,000rpm. The company appears to be new [6], but its FESS has been used in a healthcare facility [7].
- Eaton Powerware – They offer a flywheel solution capable of providing 140kW for 15 seconds (approximately 0.58kWh) [8]. They have purchased flywheel modules from Active Power (see below).
- Pentadyne – Their system, by using five cabinets, can deliver 400kW for 29 seconds of ride-through (approximately 3.2kWh) [9]. They have an FESS employed at the San Jose airport, for example [10].
- Active Power – The “CleanSource UPS”, rated for 900kVA/720kW, is able to provide 13 seconds of ride-through capability (approximately 2.5kWh) [11]. Systems up to 500kW have been sold to Eaton [12].
- AFS Trinity – Although this company does work in the flywheel area, they seem to be focusing on automotive applications [13].

Flywheel energy storage systems have also been used in transportation, specifically German light rail [14], to recover energy via regenerative braking.

Research and Development

A literature search has been performed to identify new developments in the area of flywheel energy storage systems, beyond that which is commercially available. In [15], the authors describe a system that can deliver up 50MW for 13 seconds (approximately 180kWh). Possible applications mentioned included as an uninterruptible power supply (UPS) for semiconductor manufacturing. In [16], a conceptual design for a 5MWh, 100MW system is presented for energy storage applications. This system could hypothetically provide 30 seconds of spinning reserve.

Bottlenecks

The principal bottlenecks with this technology involve getting enough energy storage by spinning the system at high enough rotational speeds, and integration of the high technology pieces required for the system.

Other issues

The existing technology for the FESS is generally applied towards UPS and other short transient applications where the high power density of the flywheel can be effectively used. No systems exist which can effectively compete with electrochemical batteries in applications requiring long duration use. However, Beacon Power seems to be developing a system for frequency regulation that exceeds the energy storage requirements of other manufacturers. Short duration (ride-through) capability up to 1MW now seems possible.

References

- [1] <http://www.beaconpower.com/products/EnergyStorageSystems/SmartEnergy25kWh.htm>
- [2] <http://www.beaconpower.com/products/EnergyStorageSystems/docs/SmartEnergyMatrix.pdf>
- [3] <http://www.renewableenergyaccess.com/rea/partner/story?id=47108>
- [4] [http://library.corporate-ir.net/library/12/123/123367/items/263107/2006 Beacon Power Annual Report.pdf](http://library.corporate-ir.net/library/12/123/123367/items/263107/2006_Beacon_Power_Annual_Report.pdf)
- [5] http://www.vyconenergy.com/pdfs/VDC_specs.pdf
- [6] <http://www.vyconenergy.com/pdfs/VYCON-2006-report.pdf>
- [7] <http://news.thomasnet.com/companystory/525830>
- [8] <http://www.powerware.com/UPS/Flywheel.asp>
- [9] <http://www.pentadyne.com/uploads/18/File/Pentadyne-VSS-Brochure.pdf>
- [10] <http://biz.yahoo.com/iw/070822/0293797.html>
- [11] http://www.activepower.com/fileadmin/documents/data_sheets/900_cleansource_ups_ds.pdf
- [12] <http://www.prnewswire.com/cgi-bin/stories.pl?ACCT=104&STORY=/www/story/02-15-2006/0004282433&EDATE=>
- [13] <http://www.afstrinity.com/index.htm>
- [14] <http://www.railway-energy.org/tfee/index.php?ID=220&TECHNOLOGYID=50&SEL=210&EXPANDALL=3>
- [15] Reiner, G.; Wehlau, N., "Concept of a 50 MW/650 MJ power source based on industry-established MDS flywheel", *Pulsed Power Plasma Science*, 2001. PPPS-2001. Digest of Technical Papers, Volume 1, Page(s):187 - 190 vol.1, 17-22 June 2001
- [16] Bornemann, H.J.; Sander, M., "Conceptual system design of a 5 MWh/100 MW superconducting flywheel energy storage plant for power utility applications", *IEEE Transactions on Applied Superconductivity*, Volume 7, Issue 2, Part 1, June 1997 Page(s):398 – 401 €
- [17] Tsao, P., Senesky, M., and Sanders, S. R., "An Integrated Flywheel Energy Storage System With Homopolar Inductor Motor/Generator and High-Frequency Drive", *IEEE Transactions on Industry Applications*, Vol. 39, No. 6, November/December 2003, pp. 1710 – 1725
- [18] http://www.beaconpower.com/products/EnergyStorageSystems/docs/Windpower_2003.pdf

Contact(s)

Remus Teodorescu, ret@iet.aau.dk.

Robert S. Weissbach, rsw7@psu.edu.

3.1.3 Vanadium flow battery

Technical description

Brief description

The vanadium redox battery (VRB) is a redox-flow battery with same electrolyte in both half-cells (Vanadium dissolved in sulphuric acid). Change of the valance of the ions depending on the state of charge ($V^{5+} \leftrightarrow V^{4+}$, $V^{2+} \leftrightarrow V^{3+}$). As in all types of redox-flow batteries the electrodes do not participate in the energy storage. The lifetime of the batteries can therefore be very long and the power and energy capacity can be sized independently. The power capacity depends on the membrane (and electrode) area and the energy capacity on the electrolyte volume. More detailed description can be found in e.g. in wikipedia [1].

System interface

The DC battery is connected to the AC grid via a power converter.

Technical data

Many of the technical claims on the performance of the vanadium battery are still not verified.

Issue	Value	Ref
Connection voltages	400 V	
Electrical efficiency (%)	~0.8	[2]
Total full load efficiency (%)	~0.8	[2]
Ramp up time (generation, 0-90%)	100 ms	
Ramp down time (consumption, 0-90%)	100 ms	

Safety issues

The large amounts of sulphuric acid are a potential risk for people in proximity of the electrolyte.

Impact

Benefits (and drawbacks/limitations) to power system

The VRB is a fast responding reserve with independent power and energy capacity. It can be used in automatic frequency control as well as remotely controlled. A major benefit to system is that the energy capacity can be designed independently on the power capacity.

Dependence on other measures

Environmental impact

There are no particular environmental issues. If there is a major leak there will be short term impact on the nearby surroundings. indirect market impact

Business issues

Costs

The technology is immature and long term performance is therefore uncertain

Issue	Value	Ref
Specific investment (M€/MW)	2.9	[2]
Technical lifetime (years)	>10	[2]
Construction time (years)	>10	[2]
Fixed O&M (€/MW/year)	1%	[2]

Manufacturers

Sumitomo, Japan

Patents

The technology is patented in USA, Japan and Australia [2].

Status

Existing installations (examples if available)

Currently installed vanadium batteries include:

Place	Time	Capacity	Function	Manufacturer	Ref
Japan	2004	1.5MW × 1 h	UPS system in a semiconductor factory	Sumitomo	[1] [4]
Hokkaido, Japan		275 kW	Wind power project in the Tomari Wind Hills		[1]
King Island, Tasmania, Australia	2003	200 kW × 4 h	Wind farm leveler at the Huxley Hill Wind Farm	Sumitomo	[1] [5]
Utah, USA		250 kW × 8 h	Load leveler in use at Castle Valley		[1]
Ireland		2 MW × 6 h	Sorne Hill 39 MW wind farm		[1] [6] [7]
Sapporo, Japan		4 MW × 1.5h			[8]
Risø DTU Denmark	2007	15 kW × 8 h	Characterisation of vanadium redox-flow batteries (test)		

Potential development

Research and development

Title	Country	Grant	Year
	Australia		
Characterisation of vanadium redox-flow batteries	Denmark	PSO 6555	2007-?

Bottlenecks

Cost reduction

Mass production of cell stacks

Other electrolytes (vanadium-bromine) for higher energy density (present energy density ??)

Other issues**References**

- [1] http://en.wikipedia.org/wiki/Vanadium_redox_battery.
- [2] N. Tassin. Investire Network, WPST 7 Redox Systems, May 2003
- [3] M. Skyllas-Kazacos and R.G. Robins, "All Vanadium Redox Battery", US Patent No. 849,094 [1986], Japan Patent Appl. [1986], Australian Patent No. 575247 [1986].
- [4] http://www.electricitystorage.org/pubs/2001/IEEE_PES_Summer2001/Miyake.pdf.
- [5] <http://www.hydro.com.au/Documents/Renewables%20Development/5882Roaring40s.pdf>
- [6] <http://www.leonardo-energy.org/drupal/node/959>.
- [7] http://en.wikipedia.org/wiki/Sorne_Hill_wind_farm.
- [8] David C. Holzman. The Vanadium Advantage: Flow Batteries Put Wind Energy in the Bank. <http://www.pubmedcentral.nih.gov/articlerender.fcgi?artid=1913571>.

Contact(s)

Henrik Bindner, henrik.bindner@risoe.dk.

3.1.4 Lead acid battery (flooded type)

Technical description

Brief description

Each cell of a lead-acid battery comprises a positive electrode of lead dioxide and a negative electrode of sponge lead, separated by a micro-porous material and immersed in an aqueous sulfuric acid electrolyte (contained in a plastic case).

The flooded lead acid battery uses an aqueous sulphuric acid solution. During discharge, the lead

dioxide on the positive electrode is reduced to lead oxide, which reacts with sulfuric acid to form lead sulfate; and the sponge lead on the negative electrode is oxidized to lead ions, that reacts with sulfuric acid to form lead sulfate. In this manner electricity is generated and during charging this reaction is reversed.

System interface

The DC battery is connected to the AC grid via a power converter.

Technical data

The lead-acid battery is the oldest and most mature technology, which has been used for majority power system applications.

Issue	Value	Ref
Connection voltages	30kV	[1]
Electrical efficiency (%)	0.45-68	[2]
Total full load efficiency (%)	~0.7	[2]
No load losses (% of installed capacity)		
Startup time	?	
Minimum operation time	0	
Minimum down time	0	
Ramp up time (generation, 0-90%)		
Ramp down time (consumption, 0-90%)		
Power factor limits (at full load)		

Safety issues

Impact

Benefits (and drawbacks/limitations) to power system

The flooded lead acid batteries require regular maintenance, the cells need to be topped up with distilled water from time to time and charged and discharged to a timetable. Further, they also suffer from self discharge (about 5% every month [3])

Dependence on other measures

Environmental impact

Neither sulphuric acid nor lead are eco-friendly so disposal is a problem and normally they are recycled.

Business issues

Costs

Manufacturers (Developers / Suppliers):

GNB Industrial Power/Exide [4], Delco [5], East Penn [6], Teledyne [7], Optima Batteries [8], JCI Battery Group [9], Trojan [10], Crown Battery [11]

Patents

Status

Existing installations (examples if available)

Currently installed lead acid batteries include:

Place	Year of Installation	Capacity	Function	Manufacturer	Ref
Puerto Rico Electric Power Authority (PREPA)	1994 [12]	20MW × 7h	Rapid spinning reserve & frequency control for utility's island system	C&D Technologies Inc. [14]	[1]
Chino California	1988 [12]	10MW × 4h	Load leveling and peak shaving		[15]
Bewag, Berlin	1986 [12]	8.5MW × 1h	Instantaneous reserve and frequency control	-	[1]

Potential development

Research and development

Title	Country	Grant	Year
Advanced Lead Acid Battery Consortium (ALBC)	-	-	Formed in 1992.

Bottlenecks

Requires regular maintenance, bulky and sensitive to temperature variations

Other issues

References

- [1] Saupe R., "The power conditioning system for the +/-8,5/17 MW-energy storage plant of BEWAG", In proceedings of Third International Conference on Power Electronics and Variable-Speed Drives, 1988, Page(s) 218-220.

- [2] <http://xtronics.com/reference/batterap.htm>
- [3] <http://www.madkatz.com/ev/batteryTechnologyComparison.html>
- [4] <http://www.exide.com/>
- [5] <http://www.acdelco.com/parts/battery/>
- [6] <http://www.eastpenn-deka.com/>
- [7] <http://www.gillbatteries.com/>
- [8] <http://www.optimabatteries.com/>
- [9] <http://www2.johnsoncontrols.com/bg/BatteryBasics/main.htm>
- [10] <http://www.trojan-battery.com/>
- [11] <http://www.crownbattery.com/>
- [12] http://electricitystorage.org/tech/technologies_leadacid.htm
- [13] Taylor P.A.,” Update on the Puerto Rico electric power authority’s spinning reserve battery system” In proceedings of Eleventh Annual Battery Conference on Applications and Advances, 1996., Page(s) 249-252.
- [14] <http://www.cdstandbypower.com/application/battery/battery.html>
- [15] Anderson M.D. and Carr D.S.,”Battery energy storage technologies”, Proceedings of the IEEE, Vol. 81, Issue 3, 1993 Page(s):475 – 479
- [16] Advanced Lead Acid Battery Consortium (ALBC), www.alabc.org/.

Contact(s)

Divya K Chandrashekhara, dkc@elektro.dtu.dk.

3.1.5 Lithium-Ion battery

Technical description

Brief description

The cathode in these batteries is a lithiated metal oxide and the anode is made of graphitic carbon with a layer structure. The electrolyte is made up of lithium salts dissolved in organic carbonates. When the battery is being charged, the Lithium atoms in the cathode become ions and migrate through the electrolyte toward the carbon anode where they combine with external electrons and are deposited between carbon layers as lithium atoms. This process is reversed during discharge.

System interface

The DC battery is connected to the AC grid via a power converter.

Technical data

Safety issues

Safety is a concern [2].

Impact

Benefits (and drawbacks/limitations) to power system

These batteries are portable. A major drawback is that its life span is dependent upon aging from time of manufacturing (shelf life) regardless of whether it was charged, and not just on the number of charge/discharge cycles [2].

Dependence on other measures

Environmental impact

Business issues

Manufacturers (Developers / Suppliers):

AGM Batteries Ltd [3], BYD company Ltd [4], Great Power Battery Co Ltd [5], Glob Tek [6]

Patents

Status

Existing installations (examples if available)

Currently used for portable devices like laptop, mobile phones.

Potential development

Bottlenecks

High cost due to special packaging and internal over charge protection [1]. Safety is also a concern.

Other issues

References

- [1] http://electricitystorage.org/tech/technologies_technologies_liion.htm
- [2] <http://www.buchmann.ca/Article5-Page1.asp>
- [3] <http://www.agmbatteries.com/>
- [4] <http://www.byd.com.cn/>
- [5] <http://www.greatpower.net/doce/company/index.htm>
- [6] <http://www.globtek.com/>

Contact(s)

Divya K Chandrashekhara, dkc@elektro.dtu.dk.

3.1.6 Sodium Sulfur battery

Technical description

Brief description

A Sodium Sulfur (NaS) battery consists of molten sulfur at the positive electrode and molten sodium at the negative electrode separated by a solid beta alumina ceramic electrolyte. The electrolyte allows only the positive sodium ions to go through it and combine with the sulfur to form sodium polysulfides. During discharge, positive sodium ions flow through the electrolyte and electrons flow in the external circuit of the battery producing about 2 volts. The battery is kept at about 300 degrees C to allow this process.

System interface

The DC battery is connected to the AC grid via a power converter.

Technical data

Issue	Value	Ref
Connection voltages	6.6kV	[3]
Electrical efficiency (%)	0.75	[5]

Safety issues

Impact

Benefits (and drawbacks/limitations) to power system

The NaS battery is much smaller and lighter than many other battery technologies. However, it operates at 300C and requires constant heat input to maintain the molten states of the electrolytes.

Dependence on other measures

Environmental impact

Business issues

Costs

Manufacturers (Developers / Suppliers):

NGK Insulators [1]

Patents

Status

Existing installations (examples if available)

Currently installed NaS batteries include:

Place	Year of Installation	Capacity	Function	Manufacturer	Ref
Japan	Under development		To stabilize output of wind farm	NGK & Tokyo Electric Power Company	[2]
Ohito Substation, Japan	1999	6MW × 4h	Electricity demand reduction	Tokyo Electric Power Company	[3]
Long Island Bus Refueling Station, USA	Turn Key	1.2MW × 6h	Peak demand reduction & back up power for the entire utility	New York Power Authority, ABB & NGK [5,6]	[4]

Potential development

Research and development

Bottlenecks

Other issues

References

- [1] <http://www.ngk.co.jp/english/products/power/nas/index.html>
- [2] <http://www.japanfs.org/db/1843-e>
- [3] Makoto Kamibayashi, "Advanced Sodium Sulfur (NaS) Battery System", Presented at IEEE PES Winter Meeting 2001-
http://electricitystorage.org/pubs/2001/IEEE_PES_Winter2001/wm01nas.pdf
- [4] Taking Wind Main Stream, IEEE Spectrum, <http://www.spectrum.ieee.org/print/3544>
- [5] Yan Kishinevsky, "Long Island bus Sodium Sulfur battery storage project", US DOE Peer Review, <http://www.sandia.gov/ess/About/docs/kishinevsky.pdf>
- [6] EPRI, "Stationary Sodium Sulfur Battery",
<http://www.epriweb.com/public/00000000001011966.pdf>

Contact(s)

Divya K Chandrashekhara, dkc@elektro.dtu.dk.

3.1.7 Zinc Bromine battery

Technical description

Brief description

In each cell of a Zinc Bromine (ZnBr) battery, two different electrolytes flow past carbon-plastic composite electrodes in two compartments separated by a micro-porous poly olefin membrane. During discharge, Zn and Br combine into zinc bromide, generating 1.8 volts across each cell. During charge, metallic zinc will be deposited (plated) as a thin film on one side of the carbon-plastic composite electrode.

System interface

The DC battery is connected to the AC grid via a power converter.

Technical data

Issue	Value	Ref
Connection voltages	480V	[1]

Safety issues

Impact

Benefits (and drawbacks/limitations) to power system

Dependence on other measures

Environmental impact

Business issues

Costs

Manufacturers (Developers / Suppliers)

ZBB Energy Corp [1], Premium Power [2]

Patents

Status

Existing installations (examples if available)

Place	Year of Installation	Capacity	Function	Manufacturer	Ref
California	2006-2007	2MW × 1h	Utility peak shaving (Demonstration)	ZBB Energy Corp	[3]
Brooklyn, New York	Under development	50kW × 2h	PV/Battery hybrid System & Utility demonstration (500kWh)	ZBB Energy Corp	[5]

Potential development

Research and development

Bottlenecks

Other issues

References

- [1] <http://www.zbbenergy.com/products/technicalpapers.htm>
- [2] <http://www.premiumpower.com/aboutrfc.php>
- [3] Peter Lex, "Demonstration of a 2-MWh Peak Shaving Z-BESS", Paper: http://www.zbbenergy.com/pdf/Techpapers_%20Demonstrationproject.pdf
Presentation Slides: http://www.zbbenergy.com/pdf/Technicalpapers_ppt.pdf
- [4] Martin H Thomas, "Persistence and Progress - The Zinc Bromine Battery in Renewable Energy Systems", http://www.zbbenergy.com/pdf/Technicalpaper_persistence.pdf
- [5] Benjamin L. Norris, Greg J. Ball, Peter Lex and, Vince Scaini, "Grid connected solar energy storage using the Zinc Bromine flow battery", http://www.zbbenergy.com/pdf/technicalpaper_grid.pdf
- [6] Benjamin L. Norris, Robert J. Parry and Raymond M Hudson, "An evaluation of windfarm stabilization and load shifting using the Zinc Bromine battery (ZBB)", http://www.zbbenergy.com/pdf/technicalpaper_evaluation.pdf

Contact(s)

Divya K Chandrashekhara, dkc@elektro.dtu.dk.

3.1.8 Metal air battery

Technical description

Brief description

The anodes in these batteries are commonly available metals with high energy density like aluminum or zinc that release electrons when oxidized. The cathodes or air electrodes are often made of a porous carbon structure or a metal mesh covered with proper catalysts. The electrolytes are often a good hydroxide(OH-) ion conductor such as Potassium hydroxide (KOH). The electrolyte may be in liquid form or a solid polymer membrane saturated with KOH.

Grid connection

The DC battery is connected to the AC grid via a power converter.

Technical data

Issue	Value	Ref
Connection voltages		
Electrical efficiency (%)	0.3-0.4 0.5 battery η , 0.6-0.8 charger η	[1]
Total full load efficiency (%)	~0.4	[1]

Safety issues

No safety issues.

Impact

Benefits (and drawbacks/limitations) to power system

The metal air batteries have low cost and high energy densities (ideal for many primary battery applications) and negligible self discharge. However, one of the main drawbacks is that recharging is very difficult.

Dependence on other measures

Environmental impact

Business issues

Costs

Manufacturers (Developers / Suppliers):

EVionyx [2], Power Zinc [3], Electric Fuel [4]

Patents

United States Patent 4913983

Status

Existing installations (examples if available)

Commercialization of zinc air batteries are under progress.

Potential development

Methods of recharging them efficiently are being investigated.

Research and development

Bottlenecks

The metal-air batteries are very difficult to be recharged.

Other issues

References

- [1] http://electricitystorage.org/tech/technologies_technologies_metalair.htm
- [2] <http://www.evonyx.com/>
- [3] <http://www.powerzinc.com/en/index.asp>
- [4] <http://www.electric-fuel.com/>

Contact(s)

Divya K Chandrashekhara, dkc@elektro.dtu.dk.

3.1.9 Regenerative fuel cell

Technical description

Brief description

Regenerative fuel cell (Polysulphide Bromide PSB or Regenesys) is a regenerative fuel cell technology that provides a reversible electrochemical reaction between two salt solution electrolytes (sodium bromide and sodium polysulphide). PSB electrolytes are brought close together in the battery cells where they are separated by a polymer membrane that only allows positive sodium ions to go through, producing about 1.5 volts.

Grid connection

The DC battery is connected to the AC grid via a power converter.

Technical data

Issue	Value	Ref
Connection voltages		
Electrical efficiency (%)	0.6-0.65	[1]

Safety issues

Impact

Benefits (and drawbacks/limitations) to power system

Like other flow batteries the energy and power rating are decoupled.

Dependence on other measures

Environmental impact

Business issues

Costs

Manufacturers (Developers / Suppliers):

Patents

Status

Existing installations (examples if available)

Currently installed PSB batteries include:

Place	Year of Installation	Capacity	Function	Manufacturer	Ref
Innogy's Little Barford Station UK		12MW × 10h		Regenesys Technologies Ltd	[2]

Potential development

Research and development

Title	Country	Grant	Year
Dalian Institute of Chemical Physics (DICP), Chinese Academy of Sciences [3], DICP-SAMSUNG Fuel Cell Joint Lab [4]	China		
Leonardo Energy [5]			

Bottlenecks

Other issues

References

- [1] Carl Johan Rydh and Bjorn A. Sanden, "Energy analysis of batteries in photovoltaic systems. Part II: Energy return factors and overall battery efficiencies", Energy Conversion and Management, Vol. 46, No. 11-12, 2005, Page(s): 1980-2000
- [2] http://electricitystorage.org/tech/technologies_technologies_psb.htm
- [3] <http://www.conference-power.com/2006/ppt/PN1-3.pdf>
- [4] <http://www.english.dicp.ac.cn/05coop/03/03.htm>
- [5] <http://www.leonardo-energy.org/drupal/files/2007/Briefing%20paper%20-%20Flow%20batteries.pdf?download>

Contact(s)

Divya K Chandrashekhara, dkc@elektro.dtu.dk.

3.2.1 HT-PEM based microCHP

Technical description

Brief description

The term microCHP is used for small domestic power producing units with an electrical power output up to approx 5 kW. In this case the microCHP unit is based on High Temperature PEM Fuel Cells.

The HT-PEM units are relatively simple, and don't need the same amount of surrounding process equipment (Often referred to as Balance Of Plant – BOP), and the fuel is hydrogen or reformed natural gas. Sensitivity to CO is not as dominant as for Low temperature PEM fuel cells.

Grid connection

The microCHP based on fuel cells all produce DC power, and they are connected to the AC grid via a power converter.

Technical data

The mCHP units are still undergoing development, so specs are only indicative

Issue	Value	Ref
Connection voltages	240 V	
Electrical efficiency (%)	~ 40	[1]
Total efficiency (%)	~ 85	[1]
Startup time – from cold	1 hour	
Startup time – from standby	0,5 minutes	

Safety issues

Impact

Benefits (and drawbacks/limitations) to power system

The HT-PEM units can be used for reformed natural gas (and other reformed fuels), and their sensitivity to CO is lower than low temperature PEM fuel cells. When operated on Hydrogen, the only by product is water vapour.

Dependence on other measures

Environmental impact

There are no particular environmental issues. Emissions from the units are dictated by the fuel that are used – natural gas will give some emission of CO₂, by using hydrogen, the combustion products will be water

Issue	Value	Ref
CO ₂ (kg/TWh)	0	
NO _x (kg/TWh)	0	
CH ₄ (kg/TWh)	0	
N ₂ O (kg/TWh)	0	

Business issues

Costs

The technology is immature and long term performance is therefore uncertain – the target prices for the units are

Issue	Value	Ref
Specific investment (M€/MW)	5	2
Technical lifetime (years)	>40.000 h	
Fixed O&M (€/MW/year)	1%	
Variable O&M (€/MWh)	0	

Manufacturers

The units described here are produced by the consortium behind the DK mCHP demonstration project

Patents

A Danish company – Serenergy – is the producer of the HT-PEM fuel cell stacks

Status

Existing installations (examples if available)

Potential development

Research and development

Bottlenecks

Cost reduction

Mass production of fuel cell stacks, and system integration

Other issues

References

[1] DK mCHP demonstration project.

[2] Target prices specified in xx

Contact(s)

Thomas Ritz Nissen.

Bruno Lund Pedersen, bruno.pedersen@danfoss.com.

3.2.2 SOFC based microCHP

Technical description

Brief description

The term microCHP is used for small domestic power producing units with an electrical power output up to approx 5 kW. In this case the microCHP unit is based on Solid Oxide Fuel Cells.

The SOFC units are especially suited for reformed fuels, as they can use CO directly within the cells, as opposed to other fuel cell types that require low levels of CO in the fuel gas.

The SOFC units theoretically have the capability of achieving very high electrical efficiencies, but they require a high degree of thermal management and relatively complex system integration due to the high process temperatures.

Grid connection

The microCHP based on fuel cells all produce DC power, and they are connected to the AC grid via a power converter.

Technical data

The mCHP units are still undergoing development, so specs are only indicative

Issue	Value	Ref
Connection voltages	240 V	
Electrical efficiency (%)	~ 35	[1]
Total efficiency (%)	~ 85	[1]
Startup time – from cold	Several hours	
Startup time – from standby	Less than 1 hour	
Minimum down time	0	

Safety issues

The unit is operating at approx 800 °C

Impact

Benefits (and drawbacks/limitations) to power system

The SOFC units are primarily thought of as base load units due to their slow start up, and the fact that they are sensitive to thermal cycling. Theoretically they should be able to achieve very high electrical efficiencies.

Dependence on other measures

Environmental impact

There are no particular environmental issues. Emissions from the units are dictated by the fuel that are used – natural gas will give some emission of CO₂, by using hydrogen, the combustion products will be water

Issue	Value	Ref
CO ₂ (kg/TWh)	0	
NO _x (kg/TWh)	0	
CH ₄ (kg/TWh)	0	
N ₂ O (kg/TWh)	0	

Business issues

Costs

The technology is immature and long term performance is therefore uncertain – the target prices for the units are

Issue	Value	Ref
Specific investment (M€/MW)	5	
Technical lifetime (years)	>40.000 h	
Fixed O&M (€/MW/year)	1%	
Variable O&M (€/MWh)	0	

^{*)} relevant for many storage components

Manufacturers

The units described here are produced by the consortium behind the DK mCHP demonstration project

Patents

Topsøe fuel cells holds several patents on the SOFC technology

Status

Existing installations (examples if available)

Currently installed mCHP units

Place	units	Capacity	Function	Manufacturer	Ref
Japan	2000				X
Germany	-				-

Potential development

Research and development

Bottlenecks

Cost reduction

Mass production of fuel cell stacks, and system integration

Other issues

References

[1] DK mCHP demonstration project.

Contact(s)

Thomas Ritz Nissen.

Bruno Lund Pedersen, bruno.pedersen@danfoss.com.

3.2.3 Alkaline Electrolysis

Technical description

The term alkaline refers to the electrolyte used which is a 25 - 30% KOH solution. The operation temperature is 80 degree Celsius and the efficiency about 80% calculated as the higher heating value of hydrogen (3.5 kWh/ Nm³) divided by the electricity consumption to produce one Nm³ of hydrogen. Plants are available on the market at sizes from 20 kW to 3 MW per unit, operating at pressures from 0 to 30 Bar.

Brief description

The technology has been used for several decades for on site production of hydrogen for industrial use. Since the price of the final product, which the hydrogen is used as a process gas for, is not very sensitive to the hydrogen price and because every plant is tailor-made the competition on the electrolyser market has been low and the prices high.

The market for electrolyser plants for energy use will be quite different from the market for industrial gasses because, on the energy market the hydrogen is the final product. Therefore it is extremely important to develop low costs plant in order to produce hydrogen that can compete as an energy carrier.

Grid connection

Production of hydrogen as a renewable energy carrier takes place by connecting the electrolyser plant to the national grid. In this way few very large and many small electrolyser plants can offer regulating power to the grid that can be used to balance large amounts of wind power.

In periods where the plants are switched on they can be switched off and in this way offer up regulating power. When they are switched off they can offer to switch on and there by offer down regulating power. Since this can take place immediately the alkaline electrolysis plants can operate on all three markets. That is the spot market with a response time of 10 hours, the regulating power market with a response time of 15 minute and the reserve power market with a response time of 5 second.

If the power supply for the electrolysers is equipped with the right advanced power supply it will also be able to offer reactive power as a system service as well.

Technical data

The alkaline electrolysis technology is for production of industrial gas a mature technology that needs further development in order to be competitive on the energy market.

Issue	Value	Ref
Connection voltages	3x400 AC	
Electrical efficiency (%)	80%	[1]
Total efficiency (%)	90	[1]
Startup time – from cold	hours	
Startup time – from standby	immediately	
Minimum down time	No minimum	
Ramp up time (generation, 25-100%)	immediately	
Ramp down time (consumption, 0-90%)	immediately	
Power factor limits (at full load)	No limit	

Safety issues

The gas code applies for hydrogen installations. Special hydrogen codes are under elaboration.

Impact**Benefits (and drawbacks/limitations) to power system**

Se above

Dependence on other measures

The price reduction on electrolyzers for energy use is to be obtained by higher efficiency of the cells and by lowering the investment costs by introducing new stack designs. Besides more advanced electrodes higher cell temperature and pressure will be necessary.

Environmental impact

There are no particular environmental issues. The plants produces only hydrogen, oxygen and heat

Issue	Value	Ref
CO ₂ (kg/TWh)	0	
NO _x (kg/TWh)	0	
CH ₄ (kg/TWh)	0	
N ₂ O (kg/TWh)	0	

Business issues**Costs**

Unit size (kW)	Price (Euro/kW)
1	13,333
10	10,035
100	4,600
1000	1,005
5000	667

Manufacturers

Western Supplier	Atmospheric plants	Pressure plants
Hydro	200 to 2000 kW	50 to 300 kW
Hydrogenics		60 to 240 kW
Iht	14 to 1500 kW	500 to 3400 kW
AccaGen		7 to 500 kW
Erre Due		100 to 200 kW
Green Hydrogen.dk	20 to 100 kW	

Patents**Status****Existing installations (examples if available)**

Currently installed mCHP units

Place	units	Capacity	Function	Manufacturer	Ref
Samsø Energiakademi	1	20 kW	Fuel station for tourist transport	GreenHydrogen	
H2College Herning	1	60 kW	Supply of 66 passive houses	GreenHydrogen	

Potential development

More advanced electrodes for higher efficiency

Higher operation temperature for higher efficiency

Higher pressure for direct storage without further compression.

Research and development

Title	Country	Grant	Year
Pre investigations of electrolysis	Denmark	PSO-F&U 2006-1-6287	2006

Bottlenecks

Cost reduction

Other issues**References**[1] Pre investigations of electrolysis **PSO-F&U 2006-1-6287****Contact(s)**Lars Yde, ly@hirc.dk.

3.3 Generation replacing base load units

Technical description

Brief description

The thermal base load units in the present Danish electricity system do not provide the flexibility which is required to in a system with e.g. 50% of electricity generation from wind power. The future thermal units will have to operate with significantly less load factors, but at the same time the capacity of such units will still be necessary in periods with low wind speed. Preferably, the new units should be characterised by a high flexibility enabling them the balance wind power fluctuations, but since most of the other measures investigated in the Ecogrid.dk project support balancing on a limited time scale (max one day), the main issue of the thermal units will be to provide capacity in longer periods with low wind speeds. For these reasons, the challenge can be more on the business side (to ensure that the capacity is available) than on the technical side (that the capacity is fast to control). This paper is not describing new types of generation, but is comparing existing types of generation based on data from the Danish technology catalogue for electricity and heat generating plants [1].

The capacity can be provided either by investment in new units or by delay of the commissioning of existing plants. Finally the need for capacity could be reduced (but probably not removed) by stronger interconnections to neighbouring countries with available capacity (Nordic hydro power capacity, provided that there is still available capacity, and taking into account new interconnections from Nordic neighbours to the continent and taking into account the wind power development in the Nordic countries)

System interface

Synchronous generators connected to transmission or distribution grid

Technical data

Technical data for selected power plants is shown below. The main source is the technology catalogue [1], but some numbers have been corrected, see notes. It is seen that the gas turbines are useful for fast reserves.

	Advanced pulverised	Large-scale biomass	Waste to energy CHP	Gas turbine single cycle	Gas turbine combined cycle	Gas turbine combined cycle	Spark ignition gas engine	
Typical capacity (MW)	400-1000	400	50	40-125	5-40	100-400	10-100	1-5
Min load (%)	20	20	75	40-60				50
Fast reserve (% / 15min)				100		100	100	100
Total eff (%)	93	90	87.9	85 ¹⁾	80 ¹⁾	88 ¹⁾	83 ¹⁾	88-96
El eff at max load (%)	48.5	45	22.5	41-42	29-38	52.5 ²⁾	52.5 ²⁾	40-44
El eff at min load (%)	< 47	< 42.5	19.5	36-38		< 50-54		38-40

¹⁾ These numbers are estimates by Jens Otto Ravn Andersen. The technology catalogue states 91 % for single cycle gas turbines (p. 38-39) and 89 % for combined cycle gas turbines (p. 44-45), but total efficiency increases from single cycle through combined cycle to spark ignition.

²⁾ From EU commission decision [2]. The technology catalogue states 56-60 % for 100-400 MW units in condensed mode and 46-54 % for 10-100 MW units in back-pressure mode at 100 % load

Safety issues**Impact****Benefits (and drawbacks/limitations) to power system****Dependence on other measures**

There will be a dependency on the market measures to ensure the necessary capacity in the future.

Environmental impact

Emission figures are available in [1].

Business issues**Costs**

The costs figures excl. fuel costs appear from the figure. The highest investment costs are on waste to energy CHP's, but for this type the fuel costs are low. The high var O&M are due to waste treatment. Generally, the fixed costs (investment and fixed O&M) are lowest for the gas turbines, which is an advantage for expected low load factors. The numbers are in 2002 values [1].

	Advanced pulverised	Large-scale biomass	Waste to energy CHP	Gas turbine single cycle		Gas turbine combined cycle		Spark ignition gas engine
Typical capacity (MW)	400-1000	400	50	40-125	5-40	100-400	10-100	1-5
Spec investment (M€/MW)	1.2	1.3	6.8	0.44-0.53 ²⁾	0.57-0.86 ²⁾	0.35-0.7 ²⁾	0.57-0.83 ²⁾	0.8-1.2
Fixed O&M (€/MW/year)	16000	25000	272000	6700-8000	8000	14000	10000	
Var O&M excl fuel (€/MWh)	1.8	2.7	25	2-3	2.5-8	1.5	2-3.5	6-9 ¹⁾

¹⁾ Total O&M

²⁾ These numbers from Technology catalogue do not reflect the fact that combined cycle turbines are significantly more expensive than single cycle turbines.

Manufacturers**Patents****Status****Existing installations (examples if available)****Potential development****Research and development**

Dedicated material research is done to increase the temperature in steam plants and thus increase efficiency and possibly flexibility

Bottlenecks

The main bottleneck is expected to be incentives to investment

Other issues

References

- [1] Technology Data for Electricity and Heat Generating Plants. Danish Energy Authority, Elkraft System, Eltra. March 2005. ISBN: 87-7844-502-7
- [2] Commission Decision of 21 December 2006 establishing harmonised efficiency reference values for separate production of electricity and heat in application of Directive 2004/8/EC of the European Parliament and of the Council (notified under document number C(2006) 6817)

Contact(s)

Poul Sørensen, poul.e.soerensen@risoe.dk.
Jens Otto Ravn Andersen, jora@ecpower.dk.

3.4 Overview of integration with district heating

In 2007 Energinet.dk decided to start phase 1 the Ecogrid project. The overall aim of the Ecogrid research programme is to develop new long term technologies and market solutions for power systems with increased share of distributed generation and renewable energy sources. The first phase of the project has the focus of identifying and describing different solutions with respect to new power system architecture and to identify new measures to support the overall goals and functions of the future power system.

Phase 1 of the Ecogrid project is divided in 5 work packages. This paper describes measures under subtask 4.2.4 “Integration with district heating”. This subtask is a part of work package 4 “Survey of new measures”. The objective of this work package “is to provide an overview of possible and likely new measures which can ensure a reliable and economic operation of the electricity power system with large scale distributed generation mainly from renewable sources, particularly wind power, in the system.”

Based on the above the focus of subtask 4.2.4 and of this paper is to describe different measures in the interplay between the district heating and the electricity system that can improve the flexibility of the electricity system. This includes flexibility in the spot market, for regulation as well as for ancillary services.

The documents for task 4.2.4 include this paper that gives an overview of the different measures and 7 appendices that describe the measures in more detail. The documents have been produced by Ea Energy Analyses with comments from IET AAU, DTU IMM and Risø DTU.

Introduction

In Denmark the district heating sector has significant impact on the operation of the power system. A large share of the electricity produced in Denmark is produced on combined heat and power plants (CHP's) and the production pattern is therefore not only governed by the demands from the electricity system but also from the district heating system.

The heat production for district heating in Denmark has risen from 79 PJ in 1980 to 130 PJ in 2006 [1]. The figure below shows the share of CHP in the electricity and heat production respectively.

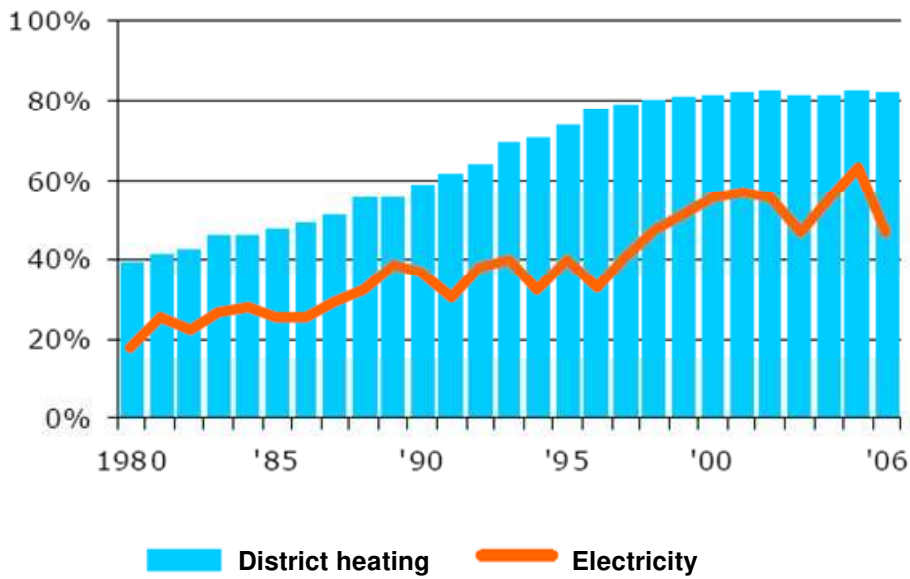

Figure 1: The CHP-share of electricity (el) and district heating production (fjernvarme) in Denmark [6].

The figure shows that the share of CHP has risen significantly in the last 25 years. Today more than 80 % of the district heating production is produced on CHP plants and the CHP share of electricity production today varies between approximately 45% and 65% depending on the electricity export from thermal units producing in condensing mode. The figure below shows the electricity production in Denmark by production form.

Electricity production by production form

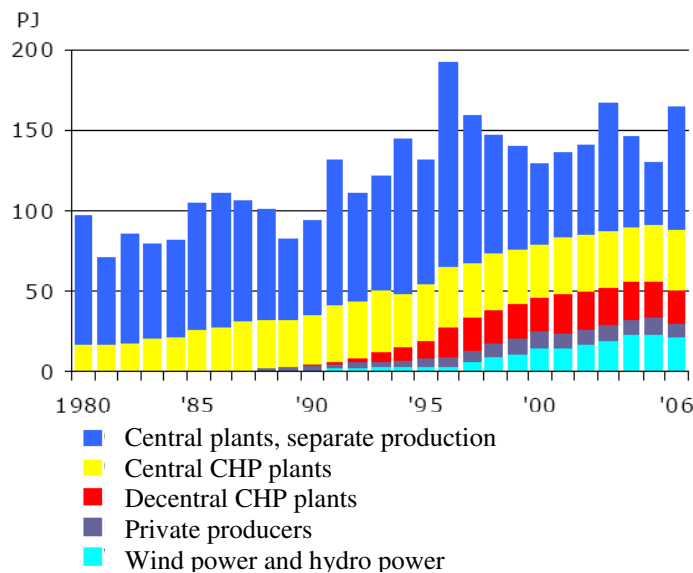

Figure 2: CHP – electricity production by production form [6].

It can be seen that the separate electricity production on central units varies from year to year whereas the production from CHP units (central, decentral and private producers) has been relatively constant over the last 5 years. The yearly production from CHP units is around 65 PJ or 18 TWh corresponding to approximately 50% of the Danish gross electricity consumption.

As shown above there is a close link between the electricity production and the district heating sector in Denmark with regard to total yearly production. However the consumption patterns of electricity and heat are different. The figure below shows the electricity consumption in Eastern Denmark and the district heating consumption in larger Copenhagen in 2004. Data is taken from the public database of the Balmorel model. The consumption is depicted as the hour by hour consumption compared with the average yearly consumption.

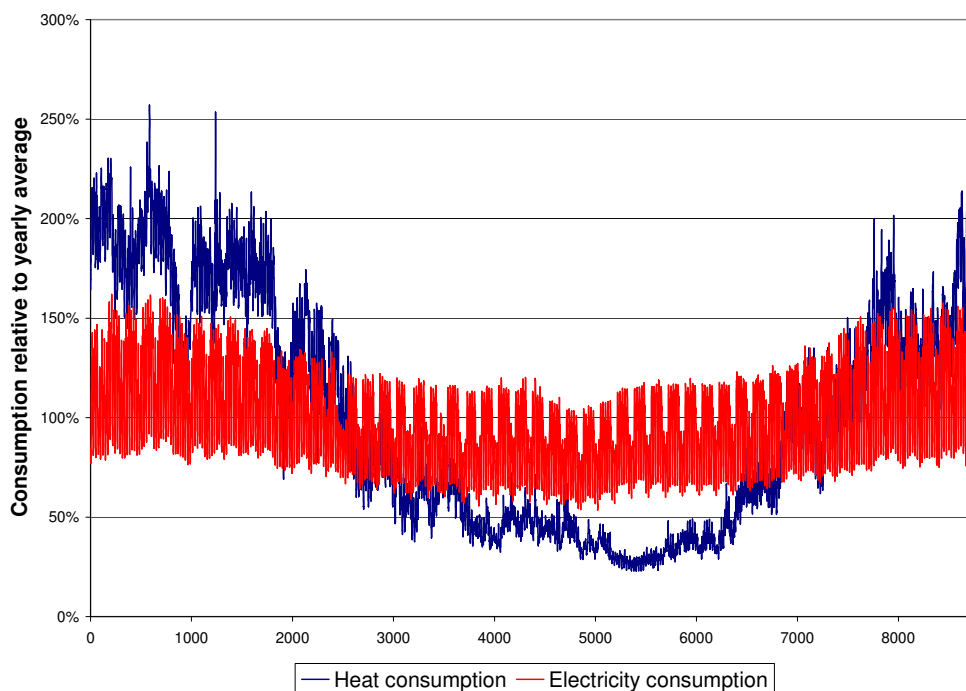

Figure 3: Consumption pattern electricity and district heating, 2004.

It can be seen that the electricity consumption is fairly independent of seasonal variations whereas the heat consumption is heavily dependent on seasonal variations.

District heating can contribute to increasing the flexibility of the electricity system

Traditionally, the production from CHP units has been governed by the heat demand with electricity as a by-product. Furthermore, the heat tax for CHP is lower than for other heat production options, thus favouring CHP for heat production.

A higher share of wind power in the electricity system will probably mean that electricity prices will be more fluctuating in the future and that the electricity production units need to be more flexible. District heating can be produced in different means and heat can be stored which is not the case for electricity. And the demand for timing of the production is also different in the heat system; heat production and consumption do not have to be in balance every second as is the case for electricity. Therefore, district heating and especially the operation of CHP plants can be used to make the electricity system more flexible.

In order to optimize benefits from integration of district heating, it is necessary to develop models of the heat load consumption that may also be used for forecast purposes [1,2] in order to optimise water flux at the supply point. Such models may also be coupled to others allowing to predict temperature at critical points of the network, initially designed for optimal control of water temperature at this same supply point [4]. In parallel, better understanding of the stochasticity of wind generation through information provided by probabilistic forecasts [4]

or statistical scenarios of short-term production [5] can be accounted for in order to develop combined optimal strategies for the operation of wind/CHP systems.

Options for more flexible electricity production on CHP plants

The following describes possibilities for using the district heating systems to make the electricity system more flexible. The description covers both possibilities that can be used in the spot market, for regulating purposes and as ancillary services.

CHP units include back pressure and extraction units. A number of technical measures exist in order to make the production on CHP plants more flexible:

- Cooling towers on back pressure units
- Turbine bypass
- On extraction units: Shift from back pressure to condensing mode => higher electricity production
- More flexible consumption of heat (technological options and consumer behaviour)
- Heat storage (diurnal and seasonal)

Furthermore other heat production technologies can help improve the flexibility of the CHP plants:

- Electric heating (dump loads)
- Large heat pumps
- Heat boilers
- Other CHP units in an interconnected district heating system

The impact of the different measures is shown in table below.

Measure	Down regulation	Up regulation
Cooling towers (Back pressure units)		X
Shift from back pressure mode to condensing mode		X
More flexible consumption of heat	X	X
Heat storage	X	X
Other CHP units in interconnected heat system	X	X
Turbine bypass	X	
Electric heating (dump loads)	X	
Large heat pumps	X	
Boilers	X	

Table 1: Impact of different measures in the district heating system.

Other options could include solar heating, district cooling, local CHP connected to the district heating network but these measures are not further described here.

Cooling towers are already today widely used on power production plants that operate in condensing mode and have no cooling water available from e.g. the sea or rivers. By establishing cooling towers on Danish CHP-plants electricity production could be available at periods where there is no heat demand.

An extraction unit operating in back pressure mode can **shift to condensing mode** and stop the heat production. This increases the electricity production and thus gives a possibility of regulating up in the electricity system. The production change is illustrated in the figure below.

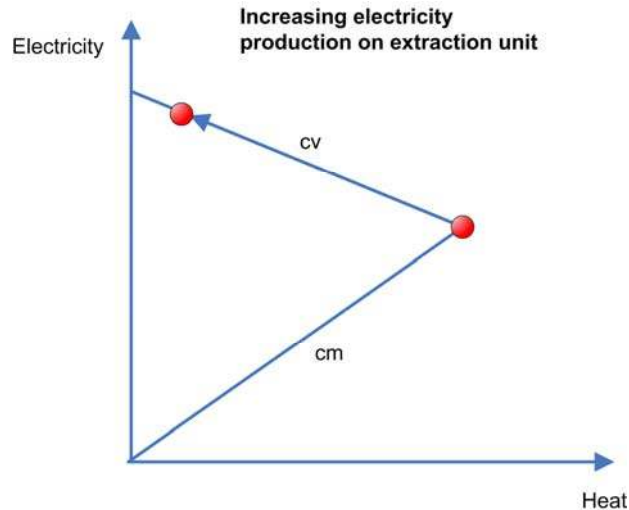

Figure 4: Shifting from back pressure to the condensing mode on an extraction unit.

In 2004 the Danish TSO, Elkraft System (now Energinet.dk), estimated that the power plants in the Copenhagen district heating area have a potential of releasing up to 200 MW of electricity production capacity on cold days.

More flexible electricity consumption can help to make the electricity system more flexible. Since the district heating and electricity system is closely connected **more flexible heat consumption** can also improve the flexibility of the electricity system. This can be achieved by technical as well as market measures.

Heat storage is an obvious measure for making the district heating production and thus the CHP units more flexible. Today most central and decentral CHP plants have heat storage facilities, but these heat storages can be utilised more efficiently and a more dynamic electricity system could also mean that establishment of more heat storage capacity could be needed.

In **larger interconnected district heating systems**, like Copenhagen, Århus and TVIS, it is also a possibility to shift between different CHP plants with a different ratio between electricity and heat production. In these systems, an intelligent planning of the production can make the electricity production more flexible. This is illustrated in the figure below.

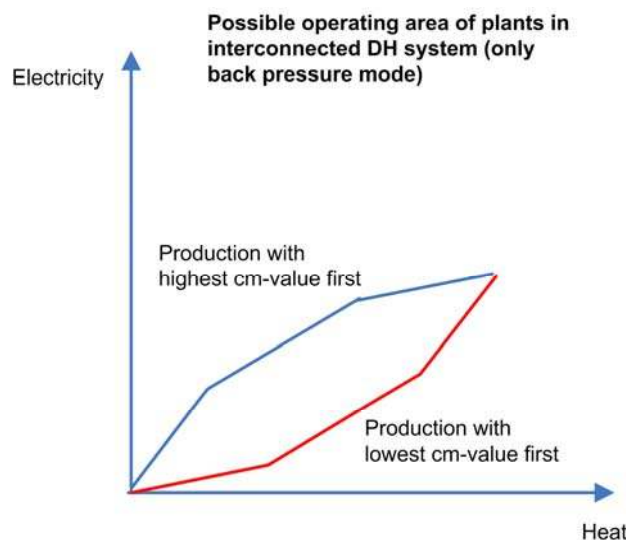

Figure 5: Possible operation of CHP units in interconnected DH system.

Dynamic use of other heat production technologies in the district heating system, like **electric heaters, large heat pumps and heat boilers**, is also an important measure to make the system more flexible. At low electricity prices an option is to stop the CHP production and produce the heat on other production technologies. These measures can be used in the spot market as well as for regulating purposes. Today, most CHP plants have an alternative production facility in the form of a boiler and many plants already use the option of producing heat on the boiler at low electricity prices. Electric heaters and large heat pumps are still only installed in very few DH systems.

Turbine bypass is possible on steam turbine plants. Instead of feeding steam from the boiler to the turbine the steam is used directly for heat production and electricity production can be reduced when there is a need for regulating down in the electricity system.

Descriptions of the following measures are included in appendices:

- Cooling towers (Back pressure units)
- Shift from back pressure mode to condensing mode
- Heat storage
- Turbine bypass
- Electric heating (dump loads)
- Large heat pumps
- Boilers

Summary

CHP covers today a large part of electricity and district heating in Denmark. Thus, measures that can dynamically integrate the production of electricity with the production and consumption of heat will be important measures to make the electricity system more flexible.

In this subtask 4.2.4 of the Ecogrid project a number of measures that integrate the electricity system with district heating has been described. The aim has been to give identify and briefly describe different measures. More thorough description of the measures and system analysis of their impact could be elements in the next phases of the Ecogrid project.

The described measures in connection with district heating differ from many other measures in the respect that they are already present in the energy system but need to be further utilised. Thus, it is not a matter of developing technology but more a matter of better utilising existing technology.

The table below gives an overview of the measures with an indication of whether they are present in the energy system today, whether they are commercially available and an indication of the costs. For many of the measures it has been difficult to assess the costs because the main reason for the investment is not for regulation in the electricity system but for district heating purposes.

Measure	Present today in the Danish system	Commercially available technology	Cost (MEuro/MW el)
Cooling towers (Back pressure units)		+	0.06 – 0.16
Shift from back pressure mode to condensing mode	+	+	-
Heat storage	+	+	-
Other CHP units in interconnected heat system	+	+	-
Turbine bypass	+	+	-
Electric heating (dump loads)		+	0.06 – 0.12
Large heat pumps		+	2 – 6
Boilers	+	+	-

Table 2: Overview of different measures in the district heating system.

Some barriers for the measures in the district heating system include:

- Taxation and legislation issues
- Planning of heat production is traditionally done day ahead. The change of heat plans due to power balancing needs to be incorporated in operation planning.
- Existing contracts between producers and district heating companies and consumers might lack the correct economic incentives.

Further analysis of measures

As mentioned this paper and the appendices give an overview of different measures in relation to the district heating system. In the next phases of the EcoGrid project some measures will be analysed in more detail. Measures for integrating the electricity and district heating system could be described and analysed further in different ways:

- More detailed assessment of technical data and costs. This includes information on regulating speed as well as operating and investment costs. A method for distributing costs between energy production of electricity and heat and for regulation purposes needs to be developed.
- Further analysis of technical barriers. This could include visiting some of the technical installations and discussions with plant owners and operation personnel.
- Assessment of potentials for up and down regulation in the electricity system of the different measures. Some numbers have been given in the appendices but these needs to be further elaborated.
- Analysis of tax incentives for different heat production technologies. Do the taxes give the right socio economic incentives for producing heat and electricity?
- System analysis of the different measures. The mentioned measures are all highly dependent on different system aspects of the heat and electricity system (other production units, electricity and district heating networks, consumption patterns of electricity and heat). In order to assess the potential impact, the environmental consequences and the socio economic costs and benefits, coherent analysis of the electricity and district heating systems needs to be undertaken.

References

- [1] Henrik Aa. Nielsen, Henrik Madsen (2006). Modelling the heat consumption in district heating systems using a grey-box approach. *Energy and Buildings*, vol 38, no 1, January 2006, Pages 63-71.
- [2] Henrik Aa. Nielsen, Henrik Madsen (2000). Predicting the Heat Consumption in District Heating Systems using Meteorological Forecasts. Technical Report, Informatics and Mathematical Modelling, Technical University of Denmark.

- [3] Pierre Pinson, Torben S. Nielsen, Henrik Aa. Nielsen, Niels K. Poulsen, Henrik Madsen (2008). Temperature prediction at critical points in district heating systems. *European Journal of Operational Research* (in press) .
- [4] Pierre Pinson, Henrik Aa. Nielsen, Jan K. Møller, Henrik Madsen, George Kariniotakis (2007). Nonparametric probabilistic forecasts of wind power: required properties and evaluation. *Wind Energy* 10 (6), pp. 497-516.
- [5] Pierre Pinson, George Papaefthymiou, Bernd Klockl, Henrik Aa. Nielsen (2007). Generation of statistical scenarios of short-term wind power production. *IEEE PowerTech Conference 2007*, Lausanne, Switzerland.
- [6] Danish Energy Authority, “Energistatistik 2006”, October 2007.
- [7] Elkraft System, “Systemplan 2004”, 2004.

Contacts

Jesper Werling, jw@eaea.dk.

3.4.1 Cooling Towers

Technical description

Brief description

Cooling towers are already today widely used on power production plants that operate in condensing mode and have no sufficient cooling water source available from e.g. the sea or rivers. If no cooling tower is available the power plant is dependent on a district heating load in order to get rid of the excess heat from the plant. By establishing cooling towers on Danish CHP-plants electricity production could be available in periods when there is no heat demand. If a large cooling water source is available the cooling can be done without a cooling tower, but by building a cooling tower the acquired amount of water can be reduced.

In the figure below the principle of a cooling tower is shown. The hot water is sprayed out in the top of the tower and cooled down by the air that comes in from below. For very large units the tower is built as hyperboloid towers which create its own updraft so no air blowers are needed. For smaller units a fan is usually used.

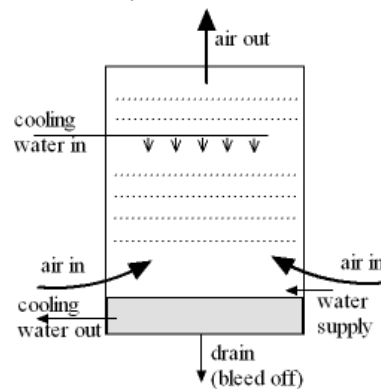

Even though the amount of water used in a cooling tower is low, it is still important that a sufficient water supply is available near the plant. This water could for example be taken from a lake or a stream near the plant. This water will be evaporated in the tower and therefore not returned to the stream.

If the CHP plant has heat storage available the cooling tower will only be necessary when the storage is full. A CHP plant with heat storage will be limited in its total production by the total heat consumption in the district heating system. By introducing a cooling tower this limitation is removed.

The circulation rate of cooling water in a typical 700 MW coal-fired power plant with a cooling tower amounts to about 71,600 cubic metres an hour [1] and the circulating water requires a supply water make-up rate of perhaps 5 percent (i.e., 3,600 cubic metres an hour). These 5 % is to replace the water that evaporates in the cooling tower. If that same plant had no cooling tower and used once-through cooling water, it would require about 100,000 cubic metres an hour [2].

Impact

Benefits (and drawbacks/limitations) to power system

During summer when the heat demand is low the production on the Danish decentralized CHP plants is limited. This is because the plants operate in back pressure mode and they are therefore dependent on a heat load for producing electricity. By establishing cooling towers – or other cooling options if the plant is close to the sea - the link between the heat and electricity production can be removed. This enables the plant to produce electricity when there is no heat load.

Environmental impact

The water that evaporates in the cooling tower will not return to the stream from which it is taken. This will lead to a reduction of the water flow downstream of the plant.

Business issues

Costs

The commercial state of the technology is mature and well known. However, it is not used on Danish CHP plants, but internationally it is widely employed.

The costs of a cooling tower are very site specific and can vary widely for different sites [1]. The costs listed below are for quite large installations and may be higher at smaller sites.

Issue	Value	Ref
Specific investment (M€/MW)	0.064 – 0.160	[1]

By comparison the costs for a gas engine plants is 0.8 – 1.2 M€/MW, so the extra cost of the cooling tower will be in the magnitude of 5 – 15 % of the plant cost. However, the extra cost for the cooling tower will need to covered in the operating hours where the plant would not produce without the cooling tower.

References

- [1] Cooling System Retrofit Costs EPA Workshop on Cooling Water Intake Technologies, John Maulbetsch, Maulbetsch Consulting, May 2003
- [2] Department of Energy Office of Fossil Energy's Power Plant Water Management R&D Program

Contacts

Jesper Werling, jw@eaea.dk

3.4.2 Shift from Back Pressure Mode to Condensing Mode

Technological description

Brief description

An extraction unit operating in back pressure mode can shift to condensing mode and stop the heat production. This increases the electricity production and thus gives a possibility of regulating up in the electricity system. The production change is illustrated in the figure below.

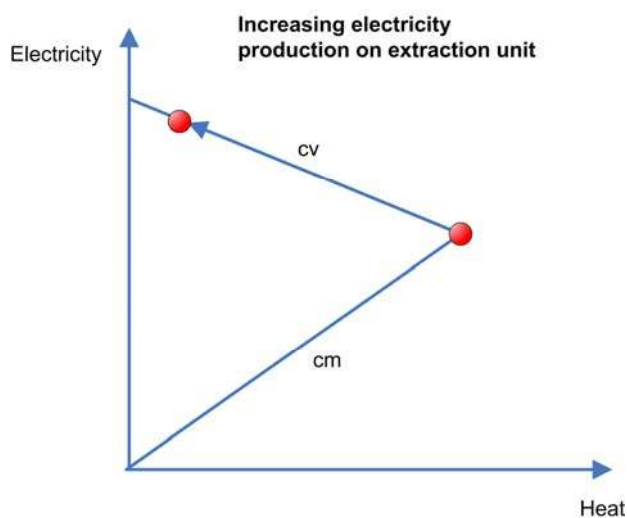

Figure 1: Shifting from back pressure to the condensing mode on an extraction unit.

Technically the ratio between heat and electricity production can be regulated by extracting steam before the medium or low pressure turbines. When using this option to produce more electricity (i.e. extracting less steam for heat) the heat production is reduced. This heat will need to be supplied from other production sources. Typically the heat can be supplied from a boiler or from a heat storage.

In 2004 the Danish TSO, Elkraft System (now Energinet.dk), estimated that the power plants in the Copenhagen district heating area have a potential of releasing up to 200 MW of electricity production capacity on cold days.

Grid connection

Most extraction units are connected to the 400 kV grid.

Technical data

When operating an extraction unit in back pressure mode the total efficiency is around 90 %. When shifting to condensing mode the total efficiency is reduced to 45 % - 60 % depending on the fuel and technology used in the extraction unit. However, the electrical efficiency is higher in condensing mode than in back pressure mode.

Data for the regulating speed has not been assessed in detail within this project.

Typical figures for large power plants (extraction units) are shown in the table below. The table shows a range for coal and gas fired plants.

Issue	Value	Ref
Connection voltages	Typically 400 kV	
Electrical efficiency (%)	48,5 – 64	[3]
Total full load efficiency (%)	89 - 93	[3]

Impact

Benefits (and drawbacks/limitations) to power system

The benefit of regulating the ratio between heat and electricity production on an extraction unit is that more power can be generated within a short time frame with a well known technology. However, reductions of the heat production for long periods of time might have an implication for the heat consumers.

Dependence on other measures

Using the possibility of shifting from back pressure to condensing mode on an extraction unit means that less heat is produced and this heat needs to be supplied in a different way. In this sense this measure is dependent on other measures like heat boilers, heat storage or other heat production options.

Environmental impact

There are no particular environmental issues other than the normal issues for producing heat and power on CHP plants. However, if heat is produced on boilers and not on CHP plants, the total fuel consumption will be higher. This in turn implies higher emissions.

Business issues

Costs

The commercial state of the technology is mature. Extraction units for heat and power production is a well known technology that is widely employed in Denmark and internationally. Once the investment in the extraction unit has been undertaken there is no or very little extra investment in making it possible to shift quickly from back pressure to condensing mode.

Economic figures for the extraction plants are shown in the table below. These figures are for the total investment in the extraction plants.

Issue	Gas CC	Coal	Ref
Specific investment (M€/MW)	0.4 – 0.7	1.1 – 1.2	[3]
Availability (%)	89 - 91	91	[3]
Technical lifetime (years)	30	30	[3]
Construction time (years)	2.5 – 3	4.5	[3]
Fixed O&M (€/MW/year)	11000 – 14000	16000	[3]
Variable O&M (€/MWh)	1.5	1.8	[3]

Status

Existing installations (examples if available)

The larger cities in Denmark that have district heating networks all have extraction units that produce heat for the network. Examples of currently installed technologies include:

Place	Time	Capacity	Function	Manufacturer	Ref
-------	------	----------	----------	--------------	-----

3.4.2 Shift from back pressure to condensing mode

Avedøreværket blok 1, Copenhagen	1990	250	Base load plant	?	[2]
Amagerværket blok 3, Copenhagen	1989	250	Base load plant	?	[2]
Fynsværket blok 7, Odense	1991	372	Base load plant	?	[2]
Nordjyllandsværket blok 3, Aalborg	1998	380	Base load plant	?	[2]
Studstrupværket blok 4, Aarhus	1985	350	Base load plant	?	[2]

Potential development

The technology is well developed. However, systems for using the capability of the technology to produce electricity and heat in a flexible manner can be further developed.

References

- [1] Elkraft System, "Systemplan 2004", 2004.
- [2] Energinet.dk, "Systemplan 2006", 2006.
- [3] Danish Energy Authority, Elkraft System and Eltra, "Technology Data for Electricity and Heat Generating Plants", March 2005.

Contacts

Jesper Werling, jw@eaea.dk

3.4.3 Heat Storage

Technical description

Brief description

Steel tanks with insulation is a well known and well tested technology that is used for smaller heat storages in connection with district heating plants. Most of the Danish CHP plants are equipped with a heat storage in order to make the heat and electricity production more flexible. In a combined heat and power system this is a very useful technological option because it gives a possibility for indirectly storing the electrical energy. Today it is complicated and expensive to store electrical energy but by employing a heat storage the electricity production can be moved in time and thus stored indirectly.

Impact

Benefits (and drawbacks/limitations) to power system

If the heat storage is full the decentralised CHP plants will not be able to produce electricity. This is because the decentralised CHP plants use the heat load from the district heating system in the condenser. This means that in periods with low heat consumption the total amount of electricity that can be produced is limited.

Dependence on other measures

The heat storage interacts with the CHP plant including other heat production options as for example heat boilers or heat pumps. There is therefore a strong interdependence between these measures.

Environmental impact

There are no particular environmental issues in direct connection with the use of the heat storage.

Business issues

Costs

The commercial state of the technology is mature. The heat storage technology for district heating is well tested in many different places.

The larger the tank the lower the specific costs will be. The price varies between 87 EUR/m³ for a tank of 4000 m³ to 175 EUR/m³ for a tank of 1000 m³ tank and up to 292 EUR/m³ for a 500 m³ tank. [1]

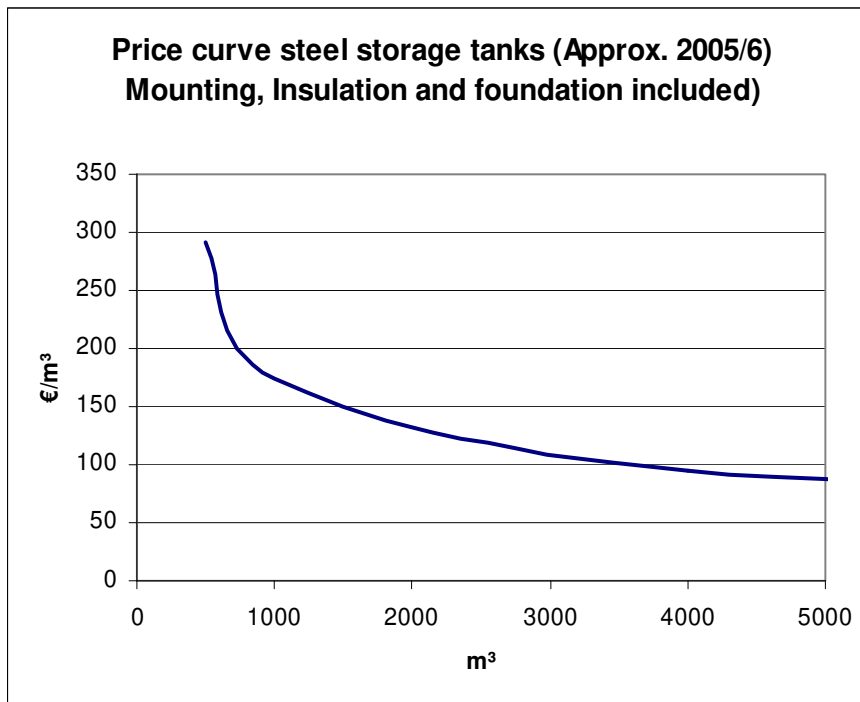

Status

Existing installations (examples if available)

Most decentralized CHP plants in Denmark have a heat storage available today. Typically it will be able to store the energy from 8 to 12 hours production time.

In total there is 1551 MW [5] decentralised CHP plants in Denmark (2006). With a cm value of approximately 0.7 and 10 hours of storage capacity this corresponds to approximately 22 000 MWh of heat storage.

Examples of larger heat storages are shown in the table below.

Place	Time	Capacity	Function
Avedøreværket	-	2400 MWh	Heat storage for Copenhagen
Amagerværket	-	800 MWh	Heat storage for Copenhagen

References

- [1] [1] "Solar heat storages in district heating networks", Energinet.dk projekt nr. 2006-2-6750 af Klaus Ellehauge og Thomas Engberg Pedersen, juni 2007
- [2] [2] Lindenberger et al: Optimization of solar district heating systems: seasonal storage, heat pumps and cogeneration, Energy artikel 2000
- [3] [3] Nielsen, J.R., H. Quicklund and J. Stang "Decision and optimization models for thermal storage in D&C systems" Paper at 9th International Symposium On District Heating And Cooling, Finland, 2004
- [4] [4] Sørensen et al: Indpasning af solvarme i kraftvarme, Energinet.dk Udredning Bilagsrapport,
- [5] [5] Energistatistik 2006, Energistyrelsen, september 2007

Contacts

Jesper Werling, jw@eaea.dk

3.4.4 Turbine Bypass

Technical description

Brief description

Turbine bypass is possible on steam turbine plants. In stead of feeding steam from the boiler to the turbine the steam is used directly for heat production and electricity production can be reduced when there is a need for regulating down in the electricity system.

By bypassing some or the entire turbine string the electrical output of the power plant can be reduced faster than it is possible to decrease the firing in the boiler. When the turbine is bypassed a lot of extra heat is sent to the condenser. This means that there will be a large increase in the heat load on the condenser. This heat must then be cooled away by cooling water or a cooling tower or used in a district heating system or heat storage.

The steam that leaves the boiler will be at high temperature and pressure. Before it can be lead to the condenser the pressure will have to be reduced through a throttling valve. It would be possible to lead all the steam around the turbines in an instant. This will happen if the turbine fails, but then the steam will be released through a safety valve to the atmosphere. In a normal situation the quantity of steam that bypasses the turbine will have to be increased gradually.

Technical data

Typical figures for large power plants (extraction units) are shown in the table below. The table shows a range for coal and gas fired plants.

Issue	Value	Ref
Connection voltages	Typically 400 kV	
Electrical efficiency (%)	48,5 – 64	[2]
Total full load efficiency (%)	89 - 93	[2]

Impact

Benefits (and drawbacks/limitations) to power system

In a situation with low electricity prices or in a critical situation with overflow of electricity turbine bypass can be employed to reduce the electricity production in the system.

Environmental impact

There are no particular environmental issues other than the normal issues for producing heat and power on CHP plants. However, if heat is produced on boilers and not on CHP plants, the total fuel consumption will be higher. This in turn implies higher emissions.

Business issues

Costs

The commercial state of the technology is well known and mature. However, not all CHP plants with steam turbines have the necessary control systems to use the turbine bypass actively in the electricity market. However, the extra costs for these modifications are low.

Economic figures for the extraction plants are shown in the table below. These figures are for the total investment in the extraction plants.

Issue	Gas CC	Coal	Ref
Specific investment (M€/MW)	0.4 – 0.7	1.1 – 1.2	[2]
Availability (%)	89 - 91	91	[2]
Technical lifetime (years)	30	30	[2]
Construction time (years)	2.5 – 3	4.5	[2]
Fixed O&M (€/MW/year)	11000 – 14000	16000	[2]
Variable O&M (€/MWh)	1.5	1.8	[2]

Status

Existing installations (examples if available)

Examples of currently installed extraction units are shown in the table below. In principle these units should be able to use turbine bypass for decreasing electricity production and increasing heat production. However, if the necessary modifications have been made on these units is not known.

Place	Time	Capacity	Function	Manufacturer	Ref
Avedøreværket blok 1, Copenhagen	1990	250	Base load plant	?	[1]
Amagerværket blok 3, Copenhagen	1989	250	Base load plant	?	[1]
Fynsværket blok 7, Odense	1991	372	Base load plant	?	[1]
Nordjyllandsværket blok 3, Aalborg	1998	380	Base load plant	?	[1]
Studstrupværket blok 4, Aarhus	1985	350	Base load plant	?	[1]

Potential development

Research and development

The technology is well developed. However, systems for using the capability of the technology to produce electricity and heat in a flexible manner can be further developed.

References

- [1] Energinet.dk, “Systemplan 2006”, 2006.
- [2] Danish Energy Authority, Elkraft System and Eltra, “Technology Data for Electricity and Heat Generating Plants”, March 2005.

Contacts

Jesper Werling, jw@eaea.dk

4.4.5 Electric Heating (dump load)

Technical description

Brief technology description

In Danish district heating networks heat is normally produced on a CHP plant or in a boiler. However, electricity can also be used for heat production. By using electricity for heat production directly to the district heating network or to heat the water in the heat storage of the plant electricity can be consumed for heat production. This can serve as an aid to the electricity system when electricity spot prices are low or when downwards regulation is needed to keep the balance in the system.

Using district heating as dump load requires an electric heating element, which consists of two electrodes immersed in a salt solution with high conductivity. Heat is released when electricity moves between the electrodes. This is used to heat the district heating water through a heat exchanger after the heat exchanger connected to the unit's main boiler.

There are some important technical issues to be kept in mind when considering the installation of an electric heating element for regulating frequency. The element's annual production time may only be a few hours annually divided over many, very short intervals. Some of which will only last for a few seconds. This allows for a much larger capacity element to be connected to heating systems than would be considered if the element were to function as continuous reserve capacity rather than frequency regulating capacity.

If longer periods of operation are required it may be necessary to enter into an agreement with heating plants on guaranteeing a certain available amount of heat load or storage capacity to ensure that elements can be activated for longer periods. Heating elements do, however, have a restriction that they cannot be activated at full capacity without notice, but generally are activated at 20% of full capacity and regulated up to full capacity within 5 to 12 minutes depending on the size of the element. This is necessary in order to maintain a balance in the saline solution. This means that it is necessary to consider the expected hours of production and the average length of activation for heating elements according to wind generation patterns before determining the required capacity and the positioning of the capacity. [1]

Technical data

Some technical data for electrical heaters for district heating purposes are shown in the table below. Electrical heaters can also be used in individual houses to replace oil or natural gas.

Issue	Value	Ref
Electrical efficiency (%)	0.95 – 1	
Start up time	5 -12 min	[1]

Impact

Benefits (and drawbacks/limitations) to power system

Electric heating can be turned on and off very fast and can therefore be use as a small fast way to regulate the power system. But the heating elements are not capable to go to full power in an instant.

Dependence on other measures

It is necessary that a district heating system is available to receive the extra heat. This could either be by storing the energy in a heat storage for future use, or by reducing the production of heat on other CHP plants or boilers.

Environmental impact

The overall energy efficiency of direct electric heating is usually low. The efficiency of generating electricity from combustion of fuels in power plants is typically only 30 to 40 percent. Thus even with a 100% efficient electric heater, the amount of fuel needed for a given amount of heat is much less than if the fuel was burned in a furnace or boiler at the building being heated.

Business issues

Costs

The cost of installing an electric heating element varies considerably with the capacity. A heating element with a capacity of 4 MW costs approximately DKK 3.7 million, 10 MW approximately DKK 4.5 million and 16 MW DKK 5 million. [1]

Issue	Value	Ref
Specific investment (M€/MW)	0,06 - 0,124	[1]
Fixed O&M (€/MW/year)	0	[4]
Variable O&M (€/MWh)	1,3	[4]

Status

Existing installations (examples if available)

Currently installed technologies include:

Place	Time	Capacity	Function	Manufacturer	Ref
Asnæsværket	?	?	Peak load	?	

References

- [1] Demand side options Bornholm Edward James-Smith Mikael Togeby Ea Energy Analyses October 2007
- [2] "DESIGN AND MODELING OF DISPATCHABLE HEAT STORAGE IN WIND/DIESEL SYSTEMS" Clint Johnson, Utama Abdulwahid, James F. Manwell, Anthony Rogers Renewable Energy Research Laboratory, Dept. of Mechanical and Industrial Engineering, University of Massachusetts, Amherst, MA 01003
- [3] Hunter, R. and G. Elliot, Eds. (1994), Wind-Diesel Systems: A Guide to the Technology and its Implementation, Cambridge, Cambridge University Press.
- [4] Langsigtede udfordringer i elsystemet, Vindkraft og naturgas, Baggrundsrapport, Elkraft system, 15. August 2005

Contacts

Jesper Werling, jw@eaea.dk

Large Heat Pumps

Technical description

Brief technology description

Heat pumps employ the same technology as refrigerators, moving heat from a low-temperature location to a warmer location. Heat pumps usually draw heat from the ambient (input heat) and convert the heat to a higher temperature (output heat) through a closed process driven by mechanical energy (drive energy) (compressor heat pumps using electricity) or absorption heat pumps (using fuel or surplus heat).

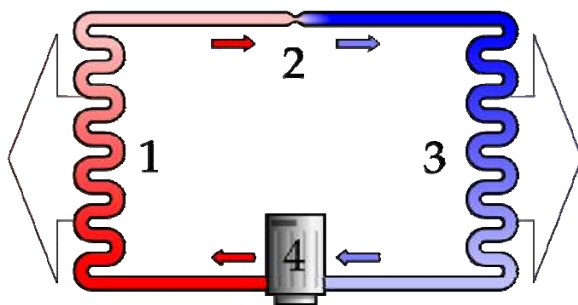

Figure 1: A simple stylized diagram of a heat pump's vapor-compression refrigeration cycle: 1) condenser, 2) expansion valve, 3) evaporator, 4) compressor

Heat pumps serve different purposes, e.g. industrial purposes, individual space heating, heat recovery and district heat production. Today all small heat pump systems used for individual space heating are driven by electricity. Large heat pump systems are primarily dimensioned from an appraisal of the actual demand.

With low temperature levels of the heat source and the delivered heat, the heat output will be 2 to 5 times (the

coefficient of performance) the drive energy.

It is not possible to make general formulas for calculating the coefficient of performance (COP) since the efficiency of the systems can vary significantly depending on the compressor type etc. A rule of thumb is that the COP increases 2-5% when the heat source raises one degree. This is only true in a relatively narrow span. Likewise, the COP increases 1-3%, when the heat delivered is lowered one degree. [1] [2]

Most commonly, heat pumps draw heat from the air or from the ground. The heat is in most cases stored solar heat for example heat stored in nearby streams and other natural water bodies. The higher energy content in the source of heat the higher COP can be obtained. [3]

In Denmark the heat source is primarily renewable energy in the form of solar heat, either directly via solar panels or via accumulated solar heat in top soil layers, in ambient air, in lakes, streams or seawater. Also waste heat from industrial processes can directly or in connection with heat recovery be utilized as heat source.

Typical Danish temperatures are 0-18 °C as ground temperature and 5-10 °C as groundwater temperature. [1]

Grid connection

Compressor heat pumps are driven by electricity or engines, whereas absorption heat pumps are driven by fuels. [1]

Technical data

The capacity of small heat pumps is 0.5 to 25 kW heat output. Large heat pumps are available from 50 to 100 MW. [3]

Technology	Very large heat pumps, electric (heat source: ambient temperature)			
	2004	2010-15	2020-30	Ref
Energy/technical data				
Generation capacity for one unit (MW heat)	50 - 100			
Coefficient of performance (A)				
- liquid/water	3.5-4.2	5	5	1
- air/water	3.2-4	5	5	1
Forced outage (%)	0	0	0	1
Planned outage (weeks per year)	0	0	0	1
Technical lifetime (years)	20	20	20	1
Construction time (years)	< 1	< 1	< 1	1
Environment				
Refrigerants (C)	partly neutral	neutral		1
Financial data				
Specific investment (M€/MW heat) (E)	0.6-1.5	0.6-1.3	0.6-1.3	2
Total O&M (€/MW heat per year) (D)	1000-3000	1000-3000	1000-3000	1
Regulation ability				
Fast reserve (MW per 15 minutes)				
Regulation speed (MW per sec.) (B)				
Minimum load (% of full load)				

References:

- 1 Danish Technology Institute. September 2004
- 2 York Refrigerants, personal communication Dec. 2004

Remarks:

- A The technology in 2004 is a two-step ammonia heat pump. The quoted COP's assume outdoor temperatures as heat source and 55 C as outlet temperature. As a rule of thumb, every extra degree on the heat source adds 4-5% to the COP. The COP's are values measured over a year. The span is due to variations in types of installations.
- B Electricity consumption regulates instantly from cold to full load
- C From 2010 it is assumed that CO₂ is used as refrigerant
- D Large heat pumps will typically contain a turbo compressor, which is almost maintenance free. O&M costs therefore only need to be calculated for the rest of the system.
- E These costs include pipes, electrical system, construction etc. The heat pumps alone would cost between 0.3 and 0.6 M€/MW heat.

Technology	Hot large heat pumps, electric (heat source: 40 C)			
	2004	2010-15	2020-30	Ref
Energy/technical data				
Generation capacity for one unit (MW heat)	5-10			
Coefficient of performance (A)				
- liquid/water (55C)	4.5	4.5	4.5	2
- liquid/water (65C)	3.9	3.9	4.3	2
- liquid/water (2004: 72C, 2010-15 and 2020-30: 75C)	3.5	3.5	4.2	1; 2
Forced outage (%)	0			1
Planned outage (weeks per year)	0			1
Technical lifetime (years)	20			1
Construction time (years)	0.5-1			1
Environment				
Refrigerants (D)	partly neutral			1
Financial data				
Specific investment (M€/MW heat) (E)	0.6-1.1	0.6-1.1	0.6	1
Total O&M (€/MW heat per year) (excl. electricity) (B)	1000-4500	1000-4500	1000	1
Regulation ability				
Fast reserve (MW per 15 minutes)	Full			1
Regulation speed (MW per sec.) (C)	0.02			1
Minimum load (% of full load)	0			1

References:

- 1 York Refrigerants, personal communication Dec. 2004
- 2 Danish Technology Institute. January 2005

Remarks:

- A The technology in 2004 and 2010-15 is a two-step ammonia heat pump. To raise the temperature above 75 degrees it is necessary to change from ammonia as refrigerant to hydrocarbons or CO₂. This is not a developed technology in this scale. As a rule of thumb, every extra degree on the heat source adds 4-5% to the COP. The COP's are values measured over a year.
- B A typical service contract is estimated 2,000-3,000 €/year, for the larger sizes. Furthermore an overall check is needed for every 10000 hrs of operation costing approximately 1500 euro/MW.
- C To raise the temperature from around 10 C average to 72 C it is necessary to have a two step heat pump, which will slow the regulation speed a bit down.
- D From 2020 it is assumed that CO₂ is used as refrigerant
- E These costs include pipes, electrical system, construction etc. The heat pumps alone would cost between 0.3 and 0.6 M€/MW heat.

[2]

Impact

Benefits (and drawbacks/limitations) to power system

The use of heat pumps can be beneficial for the overall electricity system in converting electricity to heat at high efficiencies in times of surplus electricity generation. This feature becomes increasingly valid, when more intermittent renewable energy generators are entering the system. [1] [2]

Small heat pumps have previously been operated in on/off-mode, but recently some air/air and liquid/water heat pumps have been introduced with regulation ability; typically 30-150%. In ten years time, a regulation of 10-200% is expected. Regulating up to 150-200% is only possible for shorter intervals, but could be used for peak demand. It does however shorten the lifetime of the heat pumps. [1] [2]

Large heat pumps are usually regulated continuously and instantly. In starting from cold, electricity consumption is full load instantly. [1] [2]

Environmental impact

Until the 1990s, the common refrigerants were chlorofluorocarbons (CFCs) such as freon, but its manufacture was discontinued in 1995 because of the damage that CFCs cause to the ozone layer if released into the atmosphere. One widely-adopted replacement refrigerant is the hydrofluorocarbon (HFC). Other substances such as liquid ammonia, or occasionally the less corrosive but flammable propane or butane, can also be used. In residential and commercial applications, the hydrochlorofluorocarbon (HCFC) is still widely used.

In the near future heat pumps are expected to be using CO₂ as refrigerantas this results in a higher efficiency. Furthermore by using CO₂ the temperature can be raised to 80-90°C so the pump can be used as a heat producing unit in an existing combined heat and power plant. [3]

As heat pumps need drive energy (electricity, oil or gas), the environmental impact from using heat pumps stems from the production and use of the drive energy.

Business issues

Costs

Issue	Value	Ref
Specific investment (M€/MW)	0,6 – 1,5	
Technical lifetime (years)	20	
Construction time (years)	< 1	
Total O&M (€/MW/year)	1000-4500	

[2]

In Denmark the use of heat pumps has increased dramatically (30%-50%) in the past couple of years resulting in a total sale of 15-20.000 pumps pr year. The same tendency shows in Europe as a whole as the sale of heat pumps increased with 50% from 2005 to 2006. [4]

Manufacturers

Large electric heat pumps:

- AXIMA [<http://www.axiref.com/>] (France)
- Carrier [<http://uk.carrier.com/Default.htm>] (UK)
- COOLTHERM - Kälteanlagen und Wärmepumpen GmbH [<http://www.cooltherm.de/cooltherm.html>](Germany)
- CIAT [<http://www.ciat.com/>] (France)
- CTA AG [<http://www.cta.ch/>](Switzerland)
- EUROKLIMAT [<http://www.euroklimat.it/>] (Italy)
- Friotherm AG [<http://www.friotherm.com/>] (Switzerland)
- GEA Grasso International GmbH [<http://www.grasso-global.com/>] (Netherlands)
- Johnson Controls Systems & Service GmbH [<http://www.york.de/de/html/index.html>](Germany)
- KAPAG AG [http://www.kapag.ch/d_2005/0_common/Framesets/FP0.htm](Switzerland)
- Ochsner Wärmepumpen GmbH [<http://www.ochsner.de/>] (Austria)
- SIMAKA Energie und Umwelttechnik GmbH [<http://www.simaka.de/>] (Germany)
- Skipper [<http://www.directindustry.com/prod/skipper/heat-pump-29860-131048.html>] (Italy)
- VA TECH Group [http://www.vatech.at/view.php3?r_id=21&LNG=EN] (Austria)

- Waterkotte [<http://www.waterkotte.de/en/index.html>] (Germany)
- Wesper [<http://www.wesper.com>] (France)
- ZENT-FRENGER [<http://www.zent-frenger.de>] (Germany) [6]

Status

Existing installations

In the district heating system of Stockholm, Sweden there are two large heat pumps using different techniques for extracting energy. The Värtaverket has a heat capacity of 260 MW and a cooling capacity of 48 MW. It uses saltwater from the Baltic Sea as a heat source. The heat pump is designed to withstand the corrosion from the salt. The Hammarbyverket uses leachate from a nearby sewage treatment plant as heat source and has a heat capacity of 225MW and a cooling capacity of 40 MW.

Research and development

The phasing out of the ozone depleting refrigerants CFC and HCFC from the heat pump market has been agreed internationally. The heat pump industry has introduced refrigerants, which are not ozone depleting. These are among others hydrocarbons (propane, butane and iso-butane), carbon dioxide, and water. The use of these refrigerants does not decrease the energy efficiency, on the contrary if anything. It is primarily the so called HFC refrigerants that have been developed to replace the CFC and HCFC refrigerants, but the HFC's contribute to global warming and therefore work has been initiated in order to make sure that these also are phased out. [1]

Besides the further development of environmentally neutral refrigerants it is expected that technology development will focus on:

- Increase the efficiencies of all types of heat pump systems.
- Heat pumps combined with direct solar heating.
- Use of wind power, photovoltaic electricity and biomass as input energy.
- Use of heat pumps combined with combined heat and power production.
- Optimise the benefits for the overall electricity system of using heat pumps.
- Further development of heat pumps driven by natural gas.

[1]

Other issues

Advantages/disadvantages compared to other technologies

A general advantage of heat pumps is, that the heat pump is able to utilize energy at a low temperature level. Additionally the heat pump is flexible concerning use of renewable energy, waste and surplus heat. The combined utilization of a heat source at a low temperature level and the use of for example gas as driving power enables a more effective resource utilization compared with conventional heat production technologies. [1]

Compared with traditional heating technologies, heat pumps are relatively expensive in investments costs. However, this is counterbalanced with considerable savings in operating costs. [1]

References

- [1] [Teknologikatalog Varmepumper.doc]
- [2] [Technology_Data_March05 (2)]
- [3] [Teknologiblade_MM_070711]
- [4] [Varmepumpedata 071108]
- [5] [Villavärmepumpar ET2006_25]
- [6] <http://ehpn.fiz-karlsruhe.de/en/baustein/kapitel228.html>
- [7] ET2006_01w

Contacts

Jesper Werling, jw@eaea.dk

3.4.7 Heat Boilers

Technical description

Brief technology description

Dynamic use of other heat production technologies in the district heating system, like heat boilers, is an important measure to make the system more flexible. At low electricity prices an option is to stop the CHP production and produce the heat on heat boilers. This measure can be used in the spot market as well as for regulating purposes. Today, most CHP plants have an alternative production facility in the form of a boiler and many plants already use the option of producing heat on the boiler at low electricity prices. In most cases the relevant technology will be oil fired or natural gas fired boilers.

Technical data

Gas and oil fired boilers are not connected to the electricity system and therefore have no direct impact on the electricity system. Boilers that can be used to increase the flexibility of the electricity system are normally employed as a back up heat production technology in connection with CHP's. The size of the CHP's can range from small decentral plants to large central plants and the plants can be connected to the electricity grid at all voltage levels. A few technical data are shown in the table below.

Issue	Value	Ref
Total full load efficiency (%)	97-105	[1]
Startup time	~15 minutes	

Impact

Benefits (and drawbacks/limitations) to power system

By using a heat boiler in combination with a CHP plant the heat and power production will be more flexible.

Dependence on other measures

A heat boiler can not be used as a measure by itself but needs to be employed in direct combination with a CHP plant or in combination with an interconnected district heating system with CHP plants.

Environmental impact

Heat production from a boiler primarily has environmental consequences due to the pollution to air. The table below shows the emissions from a natural gas fired boiler. In order to make a more correct assessment of the environmental consequences of producing the heat on a boiler instead of on the CHP plants a system approach needs to be taken. Electricity that is not produced on the CHP plant because of the shift to the boiler will need to be produced somewhere else in the electricity system, typically in a less efficient way.

Issue	Value	Ref
CO ₂ (kg/GJ fuel)	56,9	
NO _x (kg/GJ fuel)	0,012-0,017	[1]
SO ₂ (kg/GJ fuel)	0,00003	[1]

Business issues

Costs

The commercial state of the technology is mature. Boilers are a well known technology. The challenge is to employ the technology intelligently to make the electricity and heat production more flexible.

Issue	2004	2010-15	2020-30	Ref
Specific investment (M€/MW)	0,05-1	0,05-1	0,05-1	[1]
Availability (%)	95-97	95-97	95-97	[1]
Technical lifetime (years)	20	20	20	[1]
Construction time (years)	0,5-1	0,5-1	0,5-1	[1]
Total O&M (% of initial investment per year)	2-5	2-5	2-5	[1]
Total O&M (€/MW/year)	1000-5000	1000-5000	1000-5000	[1]

Manufacturers

There are many different manufacturers of oil and gas fired boilers for district heating plants. Some of the manufacturers include: Hollensen, Euroterm, Aalborg Boilers and Vølund.

Status

Existing installations (examples if available)

All CHP plants in Denmark have boilers for peak load and for back up heat production.

Examples of currently installed technologies include:

Place	Time	Capacity	Function	Manufacturer	Ref
Svanemølleværket boiler K21, Copenhagen	2008	270 MJ/s	Peak and back up boiler	?	
H.C. Ørsted Værket boiler K21, Copenhagen	2007	100 MJ/s	Peak and back up boiler	?	
H.C. Ørsted Værket boiler K22, Copenhagen	2007	100 MJ/s	Peak and back up boiler	?	
Hjørring	1964	23,5 MJ/s	Peak and back up boiler	?	

Potential development

The boiler technology is very well developed. However, more work can be done in developing systems to fully take advantage of the flexibility offered by using the combination of a CHP plants, a heat boiler and a heat storage to produce electricity and heat.

References

- [1] Danish Energy Authority, Elkraft System and Eltra, "Technology Data for Electricity and Heat Generating Plants", March 2005.

Contacts

Jesper Werling, jw@eaea.dk

3.5 Overview of Integration with Transportation

The study on *Integration with Transportation* is focusing on electric-drive vehicles with a battery storage capacity that can be charged from the grid, and electric-drive vehicles that are capable to provide grid services: vehicle to grid (V2G). Directly grid connected means of transportation such as electric rail transport are not included in the study. This also means that the study is focusing on passenger cars with electric drive systems which have the most important potential as a balancing measure of renewable electricity generation.

Electric Vehicle and the Grid

3 main drive technologies / vehicle types have been analyzed:

1. Battery Electric Vehicles (BEV)
2. Plug-in Hybrid Electric Vehicles (PHEV)
3. Fuel cell Electric Vehicles (FCEV)

These vehicle types are not yet in real production but they are expected to play an increasing and important role in the vehicle market of the coming decades.

The properties and the potential in relation to balancing renewable generation are different for the different vehicle types due to the supposed differences in battery capacity, electricity consumption pr. km in all-electric mode and energy efficiency in V2G transfer. So the vehicle types are analyzed separately.

Battery Electric Vehicles (BEV) has the highest potential to balance wind power and consumption. Battery Electric Vehicles are powered by relatively large batteries which are charged from the grid. Market introduction of BEV is expected to start 2010 – 2012, and as a basis for more detailed analyses specific data for these vehicles are assumed values for 2015 when the vehicles are expected to be in early mass production.

A BEV is assumed to be characterized as a small size 4-passenger car equipped with a 25 kWh lithium-ion battery which will allow an electric range of 200-250 km. This type of batteries has a very high DC-DC energy efficiency (95%). Since the average daily driving distance of a Danish passenger car is close to 40 kilometres a BEV can drive 5 to 6 days on a single charge. This gives the BEV a possibility of a very flexible charging pattern and very interesting balancing capabilities on different time scales such as:

1. Intelligent charging balancing intra hour power fluctuations
2. Charging in off-peak night periods and discharging in peak day periods balancing diurnal variations
3. Balancing wind generation variation from weather system passages (several days)

If the charging capacity during the off-peak night period is used as a simple indicator of the balancing capacity it can be stated that a BEV can balance and integrate on average 3 times the wind capacity which on a yearly basis can supply the electricity consumption of that vehicle. But the balancing potential is much higher. If we assume V2G services delivering back energy to the grid during the peak day period the BEV can store the night production from about 6 times the wind power capacity necessary for its own supply. And 12 times this capacity in a situation with an empty battery.

It is obvious that a large number of electric vehicles can deliver grid services that are very interesting for the electricity system. But for the individual car owner it is not obvious that this service is interesting from an economic point of view. The price differences between day and night periods are quite limited and the car owner must include a charging loss of about 15 % and a risk of battery wear. These simple considerations illustrate that it will be necessary to develop new incentives for car owners to be able to utilize the V2G potential in relation to integrating wind power in the electricity system.

Plug-in Hybrid Electric Vehicles (PHEV). Plug-in Hybrid Electric Vehicles are powered by a combination of an internal combustion engine and a small to medium size battery which can be charged from the grid or from a generator powered by the engine. PHEV is a further development of the Hybrid Electric Vehicle, which is already in mass production. The system architecture of PHEV's is still under development and many solutions are possible: *series, parallel or combined hybrid systems*, and operation in *blended or all-electric mode*. Market introduction of PHEV's is expected to start 2010 – 2012, and as a basis for more detailed analyses specific data for these vehicles are assumed values for 2015 when the vehicles are expected to be in early mass production.

A PHEV is assumed to be characterized as a medium size 4-5 passenger car equipped with a 10 kWh lithium-ion battery which will allow an all-electric range of up to 60 km. The hybrid drive system is more competitive for this size of car, which is heavier, uses more energy per kilometer and often used on longer distances. As the average daily distance travelled by a Danish passenger car is close to 40 kilometres this car will have a possibility of all electric drive most of the days with no restriction in driving range compared with standard gasoline and diesel cars.

However to improve battery life it is realistic that the battery will be operated within a range of may be 25 – 75 % SOC, or only 50 % of the capacity. Intelligent charging of the battery during low load night period is possible as for BEV's, but it might prove favorable for the owner to recharge the batteries during daytime. The batteries must be charged every night and the battery system will only allow for a limited flexibility in relation to V2G energy balancing services. The main V2G function is likely to be fast reserves within a limited period.

It is a theoretical possibility to start the combustion engine and generate power for the grid. But this function will be associated with a high cost and is not likely to be able to compete with other more conventional reserves. In future the available gasoline is likely to be used for transportation and not for electricity production which can be done by many other means. This solution might only be realistic in special emergency situations.

Fuel cell Electric Vehicles (FCEV). Fuel Cell Electric Vehicles are mainly powered by a fuel cell converting hydrogen to electricity. To improve energy efficiency of the fuel cell and allow regenerative braking state-of-the-art FCEV are equipped with a relatively small high power battery, similar to the battery systems known from hybrid electric vehicles. These batteries are not charged from the grid.

Many different architectures for FCEV's are possible with different combinations of battery and fuel cell capacity. One realistic extreme could be a BEV with a fuel cell as range extender. In this study the FCEV is assumed to be characterized as a medium size 4-5 passenger car equipped with a 25 kW fuel cell. The FCEV is assumed to be of the same size as the plug-in hybrid electric vehicle. The battery size is assumed to be 10 kWh lithium-ion battery, the same size as the battery pack of the supposed plug-in hybrid electric vehicles and which will allow an all-electric range of up to 60 km. This battery size optimizes the function

of the fuel cell and allows for regenerative braking capabilities. The battery is supposed to be charged from the grid.

Market introduction of FCEV is expected to start about 2020, and as a basis for more detailed analyses specific data for these vehicles are assumed values for 2025 when the vehicles could be expected to be in early mass production.

Grid services using the battery will be similar to grid services with the PHEV. In relation to the grid and integration of wind power the hydrogen production - using electrolysis - can take place at any time with excess wind power and the car does not need to be plugged in.

The theoretical possibility to deliver V2G services using the fuel cell is not realistic to be competitive with other conventional sources. Once the hydrogen has been produced it is better to use it as a transport fuel. This solution might only be realistic in special emergency situations.

Estimated size of the future fleet of electric drive vehicles (EDV)

It is obvious that the total balancing capacity of electric drive vehicles is directly related to the EDV fleet size. If PHEV's and BEV's are introduced on the market in 2010 – 2012 and in real mass production in 2015 it is a realistic – and optimistic – estimate that 10 % of the passenger car fleet in 2025 could be PHEV's and BEV's. This corresponds to a total number of about 200.000 EDV's in 2025. As an illustrative example this car fleet could be powered by 200 MW wind power capacity and store the average night production from 1.200 MW wind power. If the vehicles are plugged in using a 3 kW connection they could deliver 600 MW to the grid during a few hours.

Driving Pattern for Passenger Cars

In Denmark the annual mileage for light duty vehicles is registered and estimated in connection with the compulsory inspection of the cars every two years. The mileage is varying for different classes of car size, age and fuel system, but as an average the annual mileage for a passenger car is very close to 17.000 kilometers pr. year.

To estimate the V2G potential of electric vehicles it is assumed, that a new generation of electric drive vehicles will be used in the same pattern as conventional vehicles. It is assumed, that 3.000 kilometers are allocated to longer trips, and that the remaining 14.000 kilometers are allocated to daily trips evenly distributed over 50 weeks of the year. This means 280 kilometers pr. week and thus an average daily distance of 40 kilometers.

The private owned passenger car is often used for home to work trips in the morning, may be combined with a few other purposes. In the afternoon the car is used for work to home trips often combined with shopping, picking up children and visiting friends.

There is no direct comprehensive statistics on the driving pattern and the time used, but this pattern is reflected in numerous traffic counts which are available for many road sections. Taking the relatively short daily driving distance into account it is assumed to be safe to estimate, that an electric vehicle could be plugged-in to the grid 20 out of 24 hours given that plug-in facilities are available at the parking at home and at the workplace. This period is not considered to impose any real restrictions to the potential of V2G functionalities of energy transfer between the vehicle and the grid, taking the capacity of the battery and the transfer rate of the plug into consideration.

Grid connections

As transport is the primary purpose for the owner of the vehicle it may only be connected to the grid when it is not in use. Although the average vehicle is used for driving only about 1 hour a day practical reasons can imply a lower availability for the grid. On the other hand economic incentives related to grid services can imply a higher availability.

It is assumed that the vehicles will be connected to the grid using standard plug connection such as single phase 230 V 10/16 amps or 3-phase 400 V 16 amps. The typical grid connection is assumed to be a single phase 230 V 16 Amps plug, allowing a 3 kW energy transfer. Thus the power capacity of charging and V2G will be limited by the plug connection rather than the battery and power electronics.

If more powerful and special connections are assumed the possibility of grid connection of the vehicles will be reduced.

The necessary communication systems between the grid operators and the vehicles have not yet been analyzed, but it is assumed that battery monitoring, metering and communication systems will be an integrated part of the electronic vehicle management system.

Market Integration

Grid services

The secure and stable operation of a power system requires a number of ancillary services: short circuit current, system inertia, reactive power, reserves with different activation times: seconds, minutes and longer. Furthermore the introduction of wind power production will require back-up power when experiencing longer time periods with no wind. It will also be beneficial to have technologies enabling reduction in the variability of the electricity load minus the wind power production e.g. power consumption during low load and vice versa during high net load. This section describes the possibilities of electric-drive vehicles (EDVs) providing these services. It has in this section been assumed that fuel cell electric vehicles are designed as plug-ins, i.e. with a battery size allowing driving distances of 50-100 km only using electricity from the battery, and with the capability of being charged from the power grid.

Short circuit current will be difficult to deliver from EDVs, because the power electronics involved in AC/DC and DC/AC conversion are designed to certain current levels, and will not be able to sustain significantly higher current levels even during very short time periods.

The ability of a power system to oppose changes in frequency is called system inertia. It can loosely be defined by the mass of all the synchronous rotating generators and motors connected to the system. The power electronics in EDVs may be designed such that it can deliver ultra-fast reserves, i.e. deliver power to the grid as a response to a frequency drop with an activation time of 1-2 seconds. This might to some extent qualify as a contribution to system inertia.

According to the Nordic Grid Code [10] each of the Nordic countries are obligated to provide primary reserves. Primary reserves are up or down regulation of production to be provided within seconds. Providing primary reserves requires short response time. Primary reserves can be provided from charging or unloading of the batteries in vehicles so both battery electric vehicles (BEV), plug-in hybrid electric vehicles (PHEV) and fuel cell electric vehicles (FCEV) with large batteries are suitable.

The power to be delivered from one vehicle is typically limited by the grid connection [3]. Therefore, in order to provide reserves of 100 MW about 27,180 plugged in BEVs are needed¹. American studies have showed that even during rush hours at least 92% of the vehicles are parked/plugged in at the same time [8]. Assuming that this is also the case in Denmark, the number of BEVs/PHEVs needed in order to meet the 100 MW demand for reserves is 29,540. Using a three phase connection would reduce this number to only 9,850 BEVs/PHEVs.

	230V / 10Amps	230V / 16Amps
Number of plugged-in EDVs needed	43,480	27,180
Total number of EDVs required	47,260	29,540

The Nordic Grid Code calls for a minimum of 1000 MW of tertiary reserves for each of the Nordic countries. Tertiary reserves being reserves within minutes (a maximum of 15 minutes activation time). Providing 1000 MW of reserves within minutes could be done by any of the three types of EDVs. Considering the net revenues as calculated by both Moura [9] and Kempton et al. [5], these are strongly in favour of using BEVs for these types of reserves, due to the quite high battery-degradation costs and battery costs of the small batteries. As technology evolves, it is likely that the cost of the small batteries approach the costs of the larger ones.

Stabilising the demand curve calls for either no charge, discharge of on board batteries or power production from the engines during peak hours. In stead the vehicles could be charged at night time. The TSO being in control of when to charge will give the ultimate flexibility. All three types of EDVs could provide this service. Although, Kempton and Kubo [7] argue that the economics of using BEVs are far better because of the rather small batteries in both PHEVs and FCEVs.

From time to time we are experiencing a period of up to 2-3 weeks without wind. In these situations stored electricity from BEVs will not last long. The option here is to have either the FCEVs, PHEVs or both producing power to the grid. Since the engines will have to be running, FCEVs are preferred in these situations. Although, there are differences in wear-and-tear and maximum output of the vehicles [4].

The table below summarises the choice of vehicles to provide the different kinds of services to the grid.

	Seconds reserve	Minute reserve	Day/Night	2-3 weeks
BEV	+	+	+	-
PHEV	+	+	+	(+)
FCEV	+	+	+	+

¹ Assuming the vehicles are connected at 230V using 16amps (producing 3.7 KW).

Communication

A number of challenges are to be considered when setting up communication with the vehicles. A flow of information from the vehicles to the market is required for planning the use of the services to be provided by the EDVs [13]. Also, one could not expect the TSO to be dealing with every single vehicle. Therefore, some sort of aggregation of vehicles has to take place. Furthermore, a monitoring of the vehicles state-of-charge is needed in order to know how much charge or discharge capacity is on board each vehicle. Then, when the EDV is actually providing services to the grid, some kind of metering and settling has to take place. All the above mentioned aspects are to be discussed in this section.

Day-ahead forecasts

As the energy market works today the players have to place bids on the day-ahead market [11]. In case of the EDVs the bids would most likely contain information about the amount of power needed for charging the vehicles during the next day. In order to place the bids one would make a day-ahead forecast on the basis of a number of informations and/or assumptions; e.g. availability and need for charge. Both have to do with scheduling of the trips. Furthermore, need for charge has to do with e.g. state-of-charge, expected driving range (need for battery capacity the next day), and expectations of needed battery capacity for each trip. Since none of these parameters are known for sure, forecasts are to be made – most likely according to prior driving patterns and maybe scenarios for different states-of-charge.

As the bids representing EDVs on the day-ahead market will aggregate many vehicles thereby reducing uncertainty, and the bids will be made every day enabling a fast learning process, it is reasonable to assume that the forecast accuracy with regard to the amount and time distribution of the charging of vehicles will be high, i.e. it will be fairly easy to make day-ahead market bids representing EDVs.

Aggregators

With a minimum of 10MW to be bid on the market for minute reserves today, the electric-drive vehicles will have to be pooled. Even without the restriction on production the TSO most likely would not be dealing with every single EDV-owner. Therefore, a third party will be introduced acting as an aggregator. As mentioned by Brooks and Gage [1] and Kempton and Tomic [4], the aggregator could be one of many, e.g. a retail power delivery company, an automobile manufacturer, a cell phone network provider etc. The aggregator, adding a great number of vehicles, could offer large amounts of reserves to the power market.

One way to aggregate the EDVs could be by region (western Denmark and eastern Denmark) and by type of vehicle, because of the different grid services to be provided by the different types of EDVs. Another way could be to aggregate the vehicles in a way that ensures that each aggregator could provide all of the above mentioned services to the grid (excl. inertia and short circuit current). An aggregator could also cover fleets of vehicles parked in a number of parking facilities e.g. parked rental cars or vehicles used during work hours to be charged before the next day.

The role of the aggregator will be to place the bids in the day-ahead market and in the reserve markets. All the information needed by the TSO could be received either from the aggregator or from online communication. Also, the aggregator needs to make the choice of which vehicles to use when. In order to do so, the aggregator needs real time monitoring of the vehicles.

Monitoring the vehicles/Online communication

Real time knowledge of state-of-charge, minimum capacity required by user, interconnection capacity etc. has great importance to the planning. Monitoring could be done by computers incorporated to the vehicle measuring e.g. battery capacity and state-of-charge. These computers could be intelligent in a way that according to prior driving patterns the computer estimates the needed battery capacity. Or the computers could contain a feature where the vehicle owner types e.g. the hour of the next trip, reserved capacity for unexpected trips, and distance of next trip [6]. There is a risk in having people doing the programming, though. The optimal way would probably be for the computer to contain both features in order for the user to be able to change the data if, as an example, an expected trip differs from the standard.

Furthermore, the on board computer should be able to communicate with the aggregator in order for them to make the choice between EDVs and finding the vehicles most suitable for the services asked for by the TSO. There are a number of different factors to consider when choosing, e.g.:

- Wear-and-tear. Considering only wear-and tear of the vehicle speaks in favour of using the vehicles randomly or using the vehicles in order –using the least used vehicles first.
- Prices. One could imagine a case where we have a “negotiation” with the cars signalling a price and the service asked for. The vehicle will return a respond whether or not to actually provide the service asked for [12].
- State-of-charge. How much power can be supplied or stored from the particular vehicle.

Metering and settling

Every time a vehicle is providing services to the grid it has to somehow be metered in order to make the correct settlements afterwards. The metering could be done by the on board computer sending messages to the aggregator, either when connecting and disconnecting [2] or every time a service has been provided. The message should contain time, duration, amount of power, and type of service provided etc. According to this information the accounts could be settled every day, every week, or maybe just once a month. Today, e.g. cell-phone companies are used delivering a similar “billing” system, charging customers according to different types of use of their cell-phones.

For metering and settling the aggregator also needs to know the position of the vehicle, whether it is connected at home or not. This is to ensure, that the electricity charges or payments goes to the right vehicle owner or consumer. This information can be given through an on board GPS device, reporting the GPS position to the aggregator [1].

If we assumed that the EDVs were only connected to the grid at the home of the vehicle owner, it would be possible not to require monitoring of the charging/discharging of the vehicle directly, but only the sum of the electricity consumption of the home and the vehicle. Thereby establishing separate communication and metering due to EDVs could be avoided reducing costs on the expense of reducing the grid connection possibilities of the EDVs.

References

- [1] A.N. Brooks and T. Gage, 2001, Integration of Electric Drive Vehicles with the Electric Power Grid – A new Value Stream, EVS 18 Berlin, Germany.
- [2] A.N. Brooks, Vehicle-to-Grid Demonstration Project: Grid Regulation Ancillary Service with a Battery Electric Vehicle, 2002, Final Report, Prepared for the California Air Resources Board and the California Environmental Protection Agency.

- [3] W. Kempton and J. Tomic, Vehicle-to-grid power fundamentals: Calculating capacity and net revenue, *Journal of Power Sources*, 144 (2005), pp.268-279.
(<http://www.udel.edu/V2G/KempTom-V2G-Fundamentals05.PDF>)
- [4] W. Kempton and J. Tomic, Vehicle-to-grid power implementation: From stabilizing the grid to supporting large scale renewable energy, *Journal of Power Sources*, 144 (2005), pp.280-294. (<http://www.udel.edu/V2G/KempTom-V2G-Implementation05.PDF>)
- [5] W. Kempton, J. Tomic, S. Letendre, A. Brooks, and T. Lipman, *Vehicle-to-Grid Power: Battery, Hybrid, and Fuel Cell Vehicles as Resources for Distributed Electric Power in California*, Davis, CA: Institute of Transportation Studies Report # UCD-ITS-RR-01-03, June 2001 (<http://www.udel.edu/V2G/docs/V2G-Cal-2001.pdf>)
- [6] W. Kempton and S. Letendre, Electric vehicles as a new power source for electric utilities, *Transportation Research*, Vol. 2 (3), 1997, pp. 157-175.
- [7] W. Kempton and T. Kubo, Electric-drive vehicles for peak power in Japan, *Energy Policy* 28 (2000), pp.9-18 (<http://www.udel.edu/V2G/>)
- [8] S. Letendre and W. Kempton, The V2G Concept: A New Model For Power?, *Public Utilities Fortnightly*, February 15, 2002, pp. 16-26
(<http://www.udel.edu/V2G/docs/V2G-PUF-LetendKemp2002.pdf>)
- [9] F. Moura, Driving energy system transformation with “vehicle-to-grid” power, Interim Report IR-06-025, 2006
- [10] The Nordic Grid Code (2007), Nordel
(<http://www.nordel.org/content/default.asp?pagename=openfile&DocID=4948>)
- [11] The Nordic Power Exchange and the Nordic Model for a Liberalised Power Market, Nordpool (2006),
(<http://www.nordpoolspot.com/upload/Nordic%20power%20market/Nordic%20power%20market.pdf>)
- [12] W. Short and P. Denholm, A Preliminary Assessment of Plug-In Hybrid Electric Vehicles on Wind Energy Markets, Technical Report, NREL/TP-620-39729, April 2006 (<http://www.nrel.gov/docs/fy06osti/39729.pdf>)
- [13] H. Turton and F. Moura, Vehicle-to-grid systems for sustainable development: An integrated energy analysis, *Technol. Forecast. Soc. Change*, 2008, doi:10.1016/j.techfore.2007.11.013

Contacts

Jørgen Peter Horstmann, jph@elektro.dtu.dk.

Peter Meibom, peter.meibom@risoe.dk.

Nina Juul, njua@risoe.dtu.dk.

3.5.1 Battery Electric Vehicles (BEV)

Technical description

Brief description

Battery electric vehicles have been under development during several decades. Mainly due to the available inadequate battery technology BEV's have only been produced in a small scale and the small manufactures have not been able to push the development of the necessary advanced components.

As a consequence of the mass production of hybrid electric vehicles and the expected development of plug-in hybrid vehicles important component such as power electronics and advanced electric motors for electric cars are now in mass production and have made an important step to meet quality and price requirements of the automotive industry. For batteries the development and production of plug-in hybrid vehicles is expected to result in a similar improvement of quality and reduction of prices.

With the mass production of new advanced components the battery electric vehicles will become much more realistic. The most likely market segments will be small and light passenger cars and small commercial vans. Market introduction of BEV is expected to start 2010 – 2012. A realistic assumption of the properties of a small 4 passenger BEV produced in 2015 might be that the vehicle will be equipped with a 25 kWh battery and a range of 200 – 250 kilometers on a single charge. This vehicle will be well suited for the daily transport purposes and may be used occasionally for longer trips in combination with fast charging facilities. But it will not be adequate for very long trips.

Grid connection

As transport is the primary purpose for the owner of the vehicle it may only be connected to the grid when it is not in use. Although the average vehicle is used for driving only about 1 hour a day practical reasons can imply a lower availability for the grid. On the other hand economic incentives related to grid services can imply a higher availability.

It is assumed that the vehicles will be connected to the grid using standard plug connection such as single phase 230 V 10/16 amps or 3-phase 400 V 16 amps. The typical grid connection is assumed to be a single phase 230 V 16 Amps plug, allowing a 3 kW energy transfer. Thus the power capacity of charging and V2G will be limited by the plug connection rather than the battery and power electronics.

If more powerful and special connections are assumed the possibility of grid connection of the vehicles will be reduced.

The necessary communication systems between the grid operators and the vehicles have not yet been analyzed, but it is assumed that battery monitoring, metering and communication systems will be an integrated part of the electronic vehicle management system.

Technical data

A battery electric vehicle in a stage of early mass production in e.g. 2015 is assumed to be a small 4 passenger car with a *high energy lithium-ion* battery pack of 25 kWh. The weight of the pack will be 200-250 kg and the total weight will be similar to a car of the same size with

combustion engine. The cost of the battery pack is estimated to be in the order of 500 US\$ pr. kWh which means a total of about 12.500 US\$.

The number of possible deep cycles of the battery is assumed to be 2.000 and possibly up to 3.000 and the lifetime 10 – 15 years. It is estimated that such values will be necessary to make the electric vehicles competitive on the market, and several sources estimate such values to be realistic.

The electricity consumption of the vehicle is estimated to be about 100 Wh/km which gives the vehicle a range of about 250 km on a single charge. This means a theoretical driving distance with a battery set of 500.000 to 700.000 kilometers. This is much more than will be realized in practice and opens up for the possibility of extensive V2G activities with limited additional battery costs.

As stated above the average daily driving distance of a Danish passenger car is 40 kilometers. This means that the BEV if necessary can be used for almost one week on a single charge. This gives the vehicle owner a considerable flexibility to choose an appropriate time period for charging depending on the actual variations in electricity production from wind power, variations in electricity prices and driving needs. In combination with the high DC – DC energy efficiency of the battery (95 %) this vehicle has a very interesting potential in relation to V2G services. Intelligent charging of the batteries in off-peak periods or in periods with a surplus of electricity from wind power as well as other V2G services are realistic possibilities.

The power electronics and communication systems to allow intelligent charging from the grid and V2G-services are still in an early state of development.

Issue	Value	Ref
Connection voltages	400/230/110 V	
Electrical efficiency (%)	DC-DC ~ 95% AC-AC ~ 90%	
Total full load efficiency (%)	~ 90%	
No load losses (% of installed capacity)	< 5% pr. month	
Startup time	seconds	
Minimum operation time	0	
Minimum down time	seconds	
Ramp up time (generation, 0-90%)	seconds	
Ramp down time (consumption, 0-90%)	seconds	
Power factor limits (at full load)	~ 1	

Safety issues

The safety issues are mainly related to batteries and battery management systems.

Impact

Benefits (and drawbacks/limitations) to power system

Battery Electric Vehicles have the highest potential to balance wind power and consumption. As stated above it is possible that a BEV can drive 5 to 6 days on a single charge. This gives the BEV a possibility of a very flexible charging pattern and very interesting balancing capabilities on different time scales such as:

1. Intelligent charging balancing intra hour power fluctuations
2. Charging in off-peak night periods and discharging in peak day periods balancing diurnal variations
3. Balancing wind generation variation from weather system passages (several days)

As an average of the existing Danish wind power capacity in 2007 very close to 1 kW installed capacity deliver on a yearly basis the amount of electricity that corresponds to the annual consumption of an electric vehicle. For off-shore wind turbines the corresponding capacity is 0.5 kW. If the charging capacity during the off-peak night period is used as a simple indicator of the balancing capacity it can be stated that a BEV can balance and integrate as an average 3 times the wind capacity which on a yearly basis can supply the electricity consumption of that vehicle. But the balancing potential is much higher. If we assume V2G services delivering back energy to the grid during the peak day period the BEV can store the night production from about 6 times the wind power capacity necessary for its own supply. And as a maximum in a situation with an empty battery 12 times this capacity.

BEV's could provide very energy efficient electric storage capabilities which can improve renewable power penetration in the grid. BEV's could have a positive impact on the participation of renewables in electricity markets. Main grid services could be spinning reserves and peak load shaving.

Dependence on other measures

Development of communication systems to allow integration in the electricity market.

Environmental impact

The main advantages of the battery electric vehicle are very high overall energy efficiency in combination with a very low noise level and no emissions in the local environment. The BEV is independent of oil products and electricity can be produced from many sources, among these renewable energy sources.

The main function of BEV's in relation to the grid is electricity storage in the batteries. Since the main purpose is storage of excess electricity from wind power and thus reducing the need of electricity production with fossil fuels, the environmental impact will be positive.

Issue	Value	Ref
CO ₂ (kg/TWh)	0	
NO _x (kg/TWh)	0	
CH ₄ (kg/TWh)	0	
N ₂ O (kg/TWh)	0	

Business issues

Costs

The battery technology for BEV is still in a pre-production stage and long term performance and costs are therefore uncertain. As a basis for the analysis is used an estimated value of the costs of a high energy lithium-ion battery per kWh in an early mass production phase in 2015.

As the primary function of a BEV is transportation there is assumed no additional investment costs. However it is likely that the possibility of providing grid services could result in buying a larger battery at an additional price. Providing grid services may reduce the battery life time and these costs needs further analyses. To minimize these costs it is assumed that the battery is operated in a state of charge (SOC) in the range of 20 – 80 %.

It is obvious that a large number of electric vehicles can deliver grid services that are very interesting for the electricity system. But for the individual car owner it is not obvious that this service is interesting from an economic point of view. The price differences between day and night periods are quite limited and the car owner must include a charging loss of about 15 % and a risk of battery wear. These simple considerations illustrate that it will be necessary to

develop new incentives for car owners to be able to utilize the very interesting V2G potential in relation to integrating wind power in the electricity system.

Issue	Value	Ref
Specific investment (M€/MW)	0	
Availability (%)	80%	
Technical lifetime (years)	10 – 15 years	
Construction time (years)	0	
Fixed O&M (€/MW/year)	0	
Variable O&M (€/MWh)	?	

Manufacturers

There are many potential manufacturers of BEV's such as Mitsubishi, Toyota [1], Ford[2], General motors[3], Tesla motors[4,5], Renault, PSA, Think.

Patents

Status

Planned/demonstration projects (examples if available)

Place	Time	Capacity	Function	Manufacturer	Ref
California				California PG&E in collaboration with Google, Toyota and Ford	[6]
Japan			Tests fleets of BEV	Mitsubishi	
France			Test fleet "La Poste"	Cleanova	

Potential development

Commercially viable batteries
 Commercially viable plug-in electric vehicles
 Charging and discharging equipment and controls to ensure battery life
 Smart meters
 Communication infrastructure

Research and development

Bottlenecks

Cost reduction
 Public acceptance of the technology
 Availability of
 reliable metering, switches and communication infrastructures

Other issues

References

- [1] Adamson, K.-A. & G. Crawley, 2006B. Fuel Cell Today: 2006 Infrastructure Survey (at www.fuelcelltoday.com).
- [2] Crawley, G., 2007. Fuel Cell Today: 2007 Light Duty Vehicle Survey (at www.fuelcelltoday.com).
- [3] Edwards, R. et al, 2007. Well-to-Wheels Analysis of Future Automotive Fuels and Powertrains in the European Context (the JEC Study): CONCAWE, EUCAR and the Joint Research Centre of the EU Commission (Version 2c), Ispra, Italy.
- [4] California Fuel Cell Partnership (www.cafcp.org)
- [5] Granovskii, M. et al, 2006a. Life cycle assessment of hydrogen fuel cell and gasoline vehicles. International Journal of Hydrogen Energy, Vol. 31, pp. 337-352.
- [6] Heywood, J. B. et al, 2003. The performance of future ICE and fuel cell powered vehicles and their potential fleet impact. Laboratory for Energy and the Environment, Massachusetts Institute of Technology, Cambridge.

Contacts

Jørgen Peter Horstmann, jph@elektro.dtu.dk.

Peter Meibom, peter.meibom@risoe.dk.

3.5.2 Plug-in Hybrid Electric Vehicles (PHEV)

Technical description

Brief description

Later versions of the Toyota Prius II hybrid car are equipped with a button which permits the driver to choose an all electric driving mode. Depending on the state of charge of the battery the Prius II can be driven up to 50 km/h in a distance of 1 – 2 kilometers. This possibility inspired many persons and created a strong political pressure to develop hybrid vehicles with a larger battery pack that can be charged from the grid – the *plug-in hybrid electric vehicles*. This political pressure has emerged especially in the U.S. on the background of surging oil prices and a high political priority to reduce dependency of imported oil.

The basic concept of the PHEV is to allow that the daily driving distances can be done in all electric mode with no restrictions in the possibility of longer trips compared to conventional vehicles. On an annual basis this means that a major part of the mileage can be run on electricity from the grid and thus reduce the dependency of gasoline and oil.

There are several possible architectures for plug-in hybrid electric vehicles. As for hybrid electric vehicle possible systems are the *series hybrid system* and the *parallel hybrid system* and combinations of the two concepts. Further the size of the battery pack and thus the role of the battery can be different. The battery pack can be varied from a small high power battery similar to the existing Prius II to a large high energy battery pack supplied with a small engine with a function as range extender.

The main challenge to introduce plug-in hybrids on the market is to develop high energy batteries which can meet the requirements from the car manufactures to lifetime and costs. The first generation of plug-in hybrid vehicles is likely to be equipped with a relatively small battery capacity. But concurrently with improvements in battery technologies and production processes and price reductions it will probably be realistic to assume a battery capacity of approximately 10 kWh which can provide an all electric range of 50 – 60 kilometers on a single charge.

It is expected that plug-in hybrid vehicles will be produced for the same market segments as hybrid electric vehicles, i.e. midsize and upper markets segments of light duty vehicles. Several car manufactures have announced to introduce plug-in hybrid vehicles on the market in or around 2010.

Grid connection

As transport is the primary purpose for the owner of the vehicle it may only be connected to the grid when it is not in use. Although the average vehicle is used for driving only about 1 hour a day practical reasons can imply a lower availability for the grid. On the other hand economic incentives related to grid services can imply a higher availability.

It is assumed that the vehicles will be connected to the grid using standard plug connection such as single phase 230 V 10/16 amps or 3-phase 400 V 16 amps. The typical grid connection is assumed to be a single phase 230 V 16 Amps plug, allowing a 3 kW energy

transfer. Thus the power capacity of charging and V2G will be limited by the plug connection rather than the battery and power electronics.

If more powerful and special connections are assumed the possibility of grid connection of the vehicles will be reduced.

The necessary communication systems between the grid operators and the vehicles have not yet been analyzed, but it is assumed that battery monitoring, metering and communication systems will be an integrated part of the electronic vehicle management system.

Technical data

Market introduction of PHEV's is expected to start 2010 – 2012, and as a basis for more detailed analyses specific data for these vehicles are assumed values for 2015 when the vehicles are expected to be in early mass production. A PHEV is assumed to be characterized as a medium size 4-5 passenger car equipped with a 10 kWh lithium-ion battery which with an energy consumption in all-electric mode of 165 Wh/km allows for a theoretical all electric range of about 60 kilometres. The hybrid drive system is more competitive for this size of car, which is heavier, uses more energy pr kilometer and often used on longer distances.

As the average daily distance travelled by a Danish passenger car is around 40 kilometres this car will have a possibility of all electric drive most of the days with no restriction in driving range compared with standard gasoline and diesel cars. The PHEV is expected to be fully charged every day.

The power electronics and communication systems to allow intelligent charging from the grid and V2G-services are still in an early state of development.

Issue	Value	Ref
Connection voltages	230/110 V	
Electrical efficiency (%) using battery	DC-DC ~ 95% AC-AC ~ 90%	
Gasoline engine	35 %	
Generator	92 %	
Power electronics	95 %	
Gasoline to Grid	Tank-Grid 30 %	
Total full load efficiency (%)	~ 90%	
No load losses (% of installed capacity)	< 5% pr. month	
Startup time	seconds	
Minimum operation time	0	
Minimum down time	seconds	
Ramp up time (generation, 0-90%)	seconds	
Ramp down time (consumption, 0-90%)	seconds	
Power factor limits (at full load)	~ 1	

Safety issues

The safety issues are mainly related to batteries and battery management systems.

Impact

Benefits (and drawbacks/limitations) to power system

The battery capacity is assumed to be 10 kWh. However to improve battery life it is realistic that the battery will be operated within a range of may be 25 – 75 % SOC, or only 50 % of the capacity. The batteries must be charged every night and the battery system will only allow for a limited flexibility in relation to V2G energy balancing services. Intelligent charging of the battery during low load night period is possible as for BEV's, but it might prove favorable for the owner to recharge the batteries during daytime. The main V2G function is likely to be fast reserves within a limited period.

It is a theoretical possibility to start the combustion engine and generate power for the grid. But this function will be associated with a high cost and is not likely to be able to compete with other more conventional reserves. In future the available gasoline is likely to be used for transportation and not for electricity production which can be done by many other means. This solution might only be realistic in special emergency situations.

PHEV's can provide very energy efficient electric storage capabilities which can improve renewable power penetration in the grid. PHEV's could have a positive impact on the participation of renewables in electricity markets. Main grid services could be spinning reserves and possibly peak load shaving.

Dependence on other measures

Development of communication systems to allow integration in the electricity market.

Environmental impact

The main advantages of the PHEV are a very high overall energy efficiency in combination with a low noise level and reduced or no emissions in the local environment. The PHEV reduces the dependency of oil products with no restrictions compared to conventional cars. And electricity can be produced from many sources, among these renewable energy sources. At the same time PHEV's will improve energy efficiency in the transport sector

The main function of PHEV's in relation to the grid is electricity storage in the batteries. Since a major purpose is storage of excess electricity from wind power and thus reducing the need of electricity production with fossil fuels, the environmental impact will be positive.

Issue	Value	Ref
CO ₂ (kg/TWh)	0	
NO _x (kg/TWh)	0	
CH ₄ (kg/TWh)	0	
N ₂ O (kg/TWh)	0	

Business issues

Costs

The battery technology for PHEV is still in a pre-production stage and long term performance and costs are therefore uncertain. As a basis for the analysis is used an estimated value of the costs of a high power lithium-ion battery per kWh in an early mass production phase in 2015.

As the primary function of a PHEV is transportation there is assumed no additional investment costs. However, since the battery capacity is smaller and the battery needs to be charged every day the capabilities for grid services will be limited compared to the

BEV. Providing grid services may reduce the battery life time and these costs needs further analyses. To minimize these costs it is assumed that the battery is operated in a state of charge (SOC) in the range of 25 – 75 %.

Issue	Value	Ref
Specific investment (M€/MW)	0	
Additional energy investment costs (M€/MWh) *)	?	
Availability (%)	80% ?	
Technical lifetime (years)	High power 5–10 years High energy 10-15 years	
Construction time (years)	0	
Fixed O&M (€/MW/year)	0	
Variable O&M (€/MWh)	?	

*) relevant for many storage components

Manufacturers

There are many potential manufacturers of PHEV's such as Toyota [1], Honda Ford[2], General motors[3], PSA. . Toyota has announced to introduce a plug-in version of next generation of the Prius. As another example GM has announced to introduce the Volt which is a plug-in series hybrid. It will be provided with a relatively large battery pack. The basic concept is that the battery pack is charged from the grid and gives the vehicle an all electric range of 60 – 70 kilometers. When the battery pack is empty the gasoline engine starts and generates electricity for continuous driving. It is a part of the concept that the gasoline engine in future may be exchanged with a fuel cell and hydrogen storage system.

Patents

Status

Planned/demonstration projects (examples if available)

Place	Time	Capacity	Function	Manufacturer	Ref
California				California PG&E in collaboration with Google, Toyota and Ford	[4]
Japan			Tests fleets of PHEV	Toyota	
Japan			Test fleets of PHEV	Honda	
USA			Test fleets of PHEV	Ford + GM	
France			Test fleets of PHEV	PSA	
Sweden			Test fleets of PHEV	Saab + Volvo	

Potential development

Commercially viable batteries

Commercially viable plug-in electric vehicles

Charging and discharging equipment and controls to ensure battery life

Smart meters

Communication infrastructure

Research and development

Bottlenecks

Cost reduction

Public acceptance of the technology

Availability of reliable metering, switches and communication infrastructures

Other issues

References

- [1] Adamson, K.-A. & G. Crawley, 2006B. Fuel Cell Today: 2006 Infrastructure Survey (at www.fuelcelltoday.com).
- [2] Crawley, G., 2007. Fuel Cell Today: 2007 Light Duty Vehicle Survey (at www.fuelcelltoday.com).
- [3] Edwards, R. et al, 2007. Well-to-Wheels Analysis of Future Automotive Fuels and Powertrains in the European Context (the JEC Study): CONCAWE, EUCAR and the Joint Research Centre of the EU Commission (Version 2c), Ispra, Italy.
- [4] Heywood, J. B. et al, 2003. The performance of future ICE and fuel cell powered vehicles and their potential fleet impact. Laboratory for Energy and the Environment, Massachusetts Institute of Technology, Cambridge.

Contacts

Jørgen Peter Horstmann, jph@elektro.dtu.dk.

Peter Meibom, peter.meibom@risoe.dk.

3.5.3 Fuel cell Electric Vehicles (FCEV)

Technical description

Brief description

Fuel Cell Electric Vehicles are powered by a fuel cell converting hydrogen to electricity, possibly supplemented by electricity provided from a small to medium size battery. The latter allows the capacity, and consequently the costs, of the fuel cell to be reduced in return for added costs of the battery, and these aspects are to be weighted in the design. The fuel cell is a high-cost option, at least in the shorter term, with costs linked relatively closely to its capacity, and hence a battery supplying peak loads, and with costs linked to its storage capacity, can potentially reduce the investment costs. Furthermore this concept facilitates braking regeneration.

As onboard storage compressed hydrogen (CH₂) is assumed and consequently the hydrogen cycle is assumed to be in gaseous forms, which provide substantially higher energy-efficiency than cycles based on liquid hydrogen. In 2025, low-weight, high-pressure (700 bar) CH₂ tank technology is assumed to be available. This will allow a vehicle range roughly equivalent to a conventional automobile with weight and volume requirements that are not insurmountable for the vehicle development.

Hydrogen is produced by electrolysis as part of the project concept but it is possible to change to other hydrogen fuel cycle as a matter of course. The improvements of the present conventional electrolysis technology follow two main lines: improvement of the present types (water electrolysis) and identification and development of new types, notably polymer (PEM) and solid oxide [1]. The latter clearly has the greatest potentials but most likely with a longer time perspective than 2015/2020. Hence the data are based on the former development path. It should be noted that the mid-term perspective applied in this project is link to particularly high uncertainty in this context.

Market introduction of FCEV is generally expected to start about 2020-30, and as a basis for more detailed analyses specific data for these vehicles are assumed values for 2025 when the vehicles could be expected to be in early mass production. A FCEV is assumed to be characterized as a medium size 4-5 seats passenger car equipped with a 25 kW fuel cell and a 10 kWh lithium-ion battery which with an energy consumption in all-electric mode of 165 Wh/km allows for a theoretical battery electric range of about 60 kilometres.

Grid connection

As transport is the primary purpose for the owner of the vehicle it may only be connected to the grid when it is not in use. Although the average vehicle is used for driving only about 1 hour a day practical reasons can imply a lower availability for the grid. On the other hand economic incentives related to grid services can imply a higher availability.

It is assumed that the vehicles will be connected to the grid using standard plug connection such as single phase 230 V 10/16 amps or 3-phase 400 V 16 amps. The typical grid connection is assumed to be a single phase 230 V 16 Amps plug, allowing a 3 kW energy transfer. Thus the power capacity of charging and V2G will be limited by the plug connection rather than the battery and power electronics.

If more powerful and special connections are assumed the possibility of grid connection of the vehicles will be reduced.

The necessary communication systems between the grid operators and the vehicles have not yet been analyzed, but it is assumed that battery monitoring, metering and communication systems will be an integrated part of the electronic vehicle management system.

Technical data

Fuel cells for electric vehicles are still in a state of development to improve performance and lifetime and to reduce costs. Technical and economical data are projections for 2025. FCEV's are assumed to be equipped with a fuel cell with an energy efficiency of 60 %, electric motor efficiency of 92%.

The power electronics and communication systems to allow intelligent charging from the grid and V2G-services are still in an early state of development.

Issue	Value	Ref
Connection voltages	400/230/110 V	
Electrical efficiency (%)	Well-Tank total	
	68%	
Electrolysis	74%	[1,2]
Compression (700 bar)	97%	[2,3]
Refuelling	95%	
	Tank-Wheel total	
	55%	
Fuel cell	60%	[2,4]
Electric motor	92%	[2,4]
Onboard storage efficiency	100% ¹	[3]
	Tank-Grid 53%	[5]
	AC – AC 33%	
Total full load efficiency (%)	~ 45%	
No load losses (% of installed capacity)	< 5% pr. month	
Startup time	seconds	
Minimum operation time	15 minutes ⁰	
Minimum down time	seconds	
Ramp up time (generation, 0-90%)	seconds	
Ramp down time (consumption, 0-90%)	seconds	
Power factor limits (at full load)	~ 1	

Safety issues

The safety issues are mainly related to the fuel cell and hydrogen storage.

Impact

Benefits (and drawbacks/limitations) to power system

Hydrogen production can provide peak load shaving, but in combination with FCEV's the total energy efficiency of the electric storage are much less than for BEV's and PHEV's. FCEV's typically use 2-5 times as much energy as equivalent BEV's but for FCEV's based on gaseous hydrogen it is typically a factor 2-3 [6]. Hence, the well-to-wheel energy efficiency of the hydrogen cycle is extremely sensitive to certain key technological choices.

¹ Excluding compression losses and refuelling losses, which are included in the well-to-tank efficiency

The overall impact of the FCEV concept on the energy efficiency (including whether it will benefit or detract) depends on both the energy efficiency of the individual components and the system performance. In any case the impact will be marginal.

On the other hand the hydrogen storage has physical and economical advantages over batteries and other electricity storages, even allowing for influence of the greater losses in connection with the hydrogen cycle. Possible grid services from FCEV could be intelligent charging and spinning reserves.

Dependence on other measures

Development of communication systems to allow integration in the electricity market.

Environmental impact

The main function of FCEV's in relation to the grid is electricity storage in hydrogen production. Since the main purpose is storage of excess electricity from wind power and thus reducing the need of electricity production with fossil fuels, the environmental impact will be positive. At the same time FCEV's will reduce the oil dependence of road transport and improve energy efficiency.

Issue	Value	Ref
CO ₂ (kg/TWh)	0	
NO _x (kg/TWh)	0	
CH ₄ (kg/TWh)	0	
N ₂ O (kg/TWh)	0	

Business issues

Costs

The fuel cell technology for FCEV is still in a development stage and long term performance and costs are therefore uncertain. As a basis for the analysis is used an estimated value of the costs of fuel cells per kW in an early mass production phase in 2025.

As the primary function of a FCEV is transportation there is assumed no additional investment costs. Since the grid services from FCEV has a relatively low overall energy efficiency it is assumed it is assumed that these vehicles will mainly be used for high value grid services.

Issue	Value	Ref
Specific investment (M€/MW)	0,01-0,05 ²	[4]
Additional energy investment costs (M€/MWh) *)		
- onboard hydrogen storage	0,01 ³	[4]
- stationary distribution/refuelling infrastructure		
Availability (%)	80% ?	
Technical lifetime (years)	10 – 13 years	[4]
Construction time (years)	0	
Fixed O&M (€/MW/year)	0	
Variable O&M (€/MWh)	?	

*) relevant for many storage components

² Based on estimate \$30-80/kW in 2015 and \$15-80/kW in 2020 [10, p. 124]

³ Based on \$16/kWh [10, p. 72]

The specific costs per unit stored energy of hydrogen storages are generally much lower than for electricity storage technologies and also the required {space} Hence much greater storage capacity is generally viable for hydrogen.

Manufacturers

Most of the big automobile manufacturers have been engaged in RDD related to FCEV’s [4,7,8,9]. The most important manufacturers involved are:

- Daimler Chrysler involved in FCEV-development since the mid-1990s and in hydrogen driven transport since the 1970s
- General Motors
- Honda
- Ford
- Toyota
- Hyundai
- Nissan

Among the manufacturers involved there is a generic consensus that 2012-2015 is a likely time frame for introduction of FCEV’s (as light duty vehicles) in the transport sector but a likely time frame for mass scale commercialisation of FCEV’s according to industry commentators is 2020-2025 [8].

The most likely first application of hydrogen for transport purposes is in bus transport rather than as automobile fuel [4, 7, 9]. There is general consensus, however, that only the automobile sector can act as a driver for the technological development required.

There has been a number of projects testing hydrogen/fuel cells in bus transport, e.g.

- various projects within the EU (CUTE, Iceland)
- California
- USA/Canada
- Japan

(infrastructure)

Patents

Status

Planned/demonstration projects (examples if available)

Place	Time	Capacity	Function	Manufacturer	Ref
California			Test fleets of FCEV	Toyota and Ford	[4,9]
Japan			Test fleets of FCEV	Toyota	
Japan			Test fleets of FCEV	Honda	
Germany			Test fleets of FCEV	Mercedes	
Germany			Prototypes	Opel	

Potential development

Commercially viable fuel cells
 Commercially viable fuel cell electric vehicles

Smart meters
Communication infrastructure

Research and development

Bottlenecks

Cost reduction
Public acceptance of the technology
Availability of reliable metering, switches and communication infrastructures

Other issues

Making the technology simple and easy to use, so that no technical knowledge is required.

References

- [1] IEA Hydrogen Co-ordination Group, 2005. Prospects for Hydrogen and Fuel Cells, IEA Energy Technology Analysis Series, Paris,
- [2] Edwards, R. et al, 2007. Well-to-Wheels Analysis of Future Automotive Fuels and Powertrains in the European Context (the JEC Study): CONCAWE, EUCAR and the Joint Research Centre of the EU Commission (Version 2c), Ispra, Italy.
- [3] Yang C. & J. M. Ogden, 2007. Determining the lowest-cost hydrogen delivery mode, International Journal of Hydrogen Energy Vol. 32, pp. 268-286.
- [4] Kalhammer, F. et al, 2007, Status and prospects for Zero Emission Vehicle Technology – Report of the ARB Independent Expert Panel 2007. State of California Air Resources Board, Sacramento.
- [5] Kempton, W. et al, 2001. Vehicle-to-Grid Power: Battery, Hybrid, and Fuel Cell Vehicles as Resources for Distributed Electric Power in California. Institute of Transportation Studies, University of California, Davis
- [6] Jørgensen, K., 2008. Technologies for electric, hybrid and hydrogen vehicles: Electricity from renewable energy sources in transport. Utilities Policy, Vol. 16, pp. 72-79.
- [7] Adamson, K.-A. & G. Crawley, 2006A. Fuel Cell Today: 2006 Bus Survey (at www.fuelcelltoday.com).
- [8] Crawley, G., 2007. Fuel Cell Today: 2007 Light Duty Vehicle Survey (at www.fuelcelltoday.com).
- [9] California Fuel Cell Partnership (www.cafcp.org)

Contacts

Jørgen Peter Horstmann, jph@elektro.dtu.dk.
Peter Meibom, peter.meibom@risoe.dk.

3.6 Overview of FACTS – Flexible AC Transmission Systems



I. Introduction

Wind energy has emerged as the fastest growing source of energy, with 74,223 MW installed throughout the world at the end of 2006 according to the Global Wind Energy Council. Wind power is expected to see continued strong growth in the immediate future. It is projected to provide a total cumulative world-wide capacity of 117,000 MW (roughly 1.25% of the world's electricity generation) by 2009 according to BTM Consult ApS. As the total base of installed wind capacity continues to grow with the installation of additional wind turbines and new wind farms, compliance with interconnection criteria becomes increasingly important. In many cases, dynamic voltage regulation and continuous power factor correction are required to keep wind turbine generators online.[13]

Many of today's wind turbines are induction type generators that absorb large amounts of VARs (Volt-Amperes Reactive) from the grid. For such machines, VAR flow fluctuates with the power output of the turbines. These variations in VAR flow can cause severe voltage fluctuations, affecting overall power quality and the reliability of the grid. Traditionally, switched capacitors have been used to compensate for fluctuating VAR requirements. Such frequent switching can reduce life-cycle times of the capacitor switches. In addition, some gearboxes are sensitive to large step changes in voltage associated with normal capacitor switching, which can overstress the gearbox, one of the costliest components of a wind turbine.

Keeping wind turbines online under low voltage conditions is also a potential trouble spot that developers and operators need to consider. Most interconnection standards today require wind farms to have the ability to ride through faults (Low Voltage Ride Through).

Benefits of FACTS

The power industry term FACTS (Flexible AC Transmission Systems) covers a number of technologies that enhance the security, capacity and flexibility of power transmission systems. FACTS solutions enable power grid owners to increase existing transmission network capacity while maintaining or improving the operating margins necessary for grid stability. As a result, more power can reach consumers, giving some benefits:

- Localized voltage collapse problems.
- Increasing power transfer through stability limited systems.
- Wind farm voltage regulation / low voltage ride through.
- Voltage regulation on radial lines, and in weak grids.
- Mitigating industrial voltage transients.
- Reliable grid connection.
- Facilitates grid connections in remote areas without need for grid reinforcements.
- AC grid enhancements.
- Short installation and implementation time.

3.6 Overview of FACTS

- Low project risk by:
 - Easy permitting.
 - Short construction and commissioning time.
 - Minimizing time from decision to commercial operation.
- Flexible, modular systems
- Modular systems can be staged and installed to meet capacity demand.
- Low operation and maintenance costs.

II. Examples of FACTS used in wind farms

HVDC Light

Gotland

Description of the installation:

The Gotland **HVDC Light** system was commissioned in 1999. Its rating is 50 MW and 65 MVA and it is connected in parallel with the existing 70 kV / 30 kV AC grid. The Gotland island system has a peak load of about 160 MW and today there are a total of 165 windmills with a total installed power of 90 MW producing about 200 GWh. The short circuit power from the AC grid is less than 60 MVA at the connection point in Näs, where the wind power production is connected for the HVDC Light system. The grid operator, Gotlands Energi AB (GEAB) considered that HVDC Light system would be the only realistic way to solve the technical problems with the high amount of wind power in-feed.

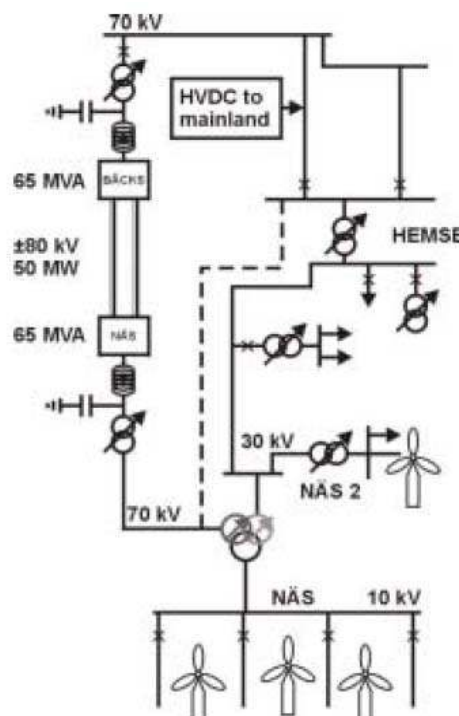

Figure 1. Simplified diagram of the Gotland network. [6]

Benefits of using the HVDC Light in the system:

The experiences have supported expected improvements in characteristics such as:[7]

- Reliable grid connection.
Facilitates grid connections in remote areas without need for grid reinforcements.
- Can connect any type of windmill technology.
- Easier permit procedure
Underground invisible cable system.
Environmental friendly oil-free cables.
Short installation and implementation time.
Environmentally adapted converter stations.
- Low project risk by
Easy permitting.
Short construction and commissioning time.
- Flicker problems were eliminated with the installation of HVDC Light and transient phenomena disappeared.
- Stability in the system arose.
- Power flows, reactive power demands, as well as voltage levels in the system and harmonics were reduced.
- Low operation and maintenance costs.

One result is that the voltage stability during transient events has become much better with HVDC Light, which improves the output current stability from the asynchronous generators. This reduces not only the stresses on the AC grid but also on the mechanical construction of the windmills. Overall experiences are that the control of power flow from the converters makes the AC grid easier to supervise than a conventional AC network and the power variations do not stress the AC grid as much as in normal networks. Voltage quality has also been better with the increased wind power production [1],[2].

Tjæreborg

Description of the installation:

The **HVDC Light** transmission is in service since 2000, with a rating of 7.2MW, 8MVA, consists of two Voltage Source Converters (VSC) and two ± 9 kV d.c. cables.

The DC pole cables have been installed in parallel with the existing AC cables, the sending end converter is installed at the wind farm, and the receiving end converter is installed in the Tjæreborg substation.

The Tjæreborg wind farm consists of four wind turbines (WTs) with a total installed capacity of 6.5 MW and is a test installation.

- Two 2.0 MW WT, with doubly fed asynchronous wind turbine generators (WTGs).
- One 1,5 MW directed connected asynchronous WTG.
- One 1.0 MW with a full converter.

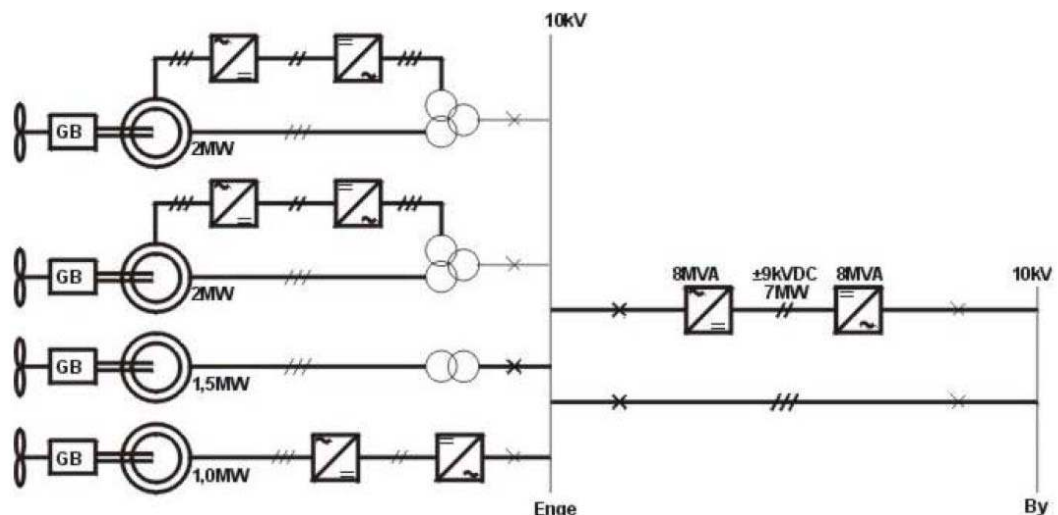

Figure 2. The Tjæreborg wind farm with AC and DC cable feeders. [6]

The VSC converters operates with Pulse Width Modulation PWM technique, and the nominal commutation frequency is 1950 Hz. The active components in the valves are IGBTs.[8]

The purpose was to investigate how the controllability of the VSC transmission as well as optimal exploitation of the wind energy by using the converter for providing a collective variable frequency to the WTGs.

Benefits of using the HVDC Light in the system:

Simulation of three-phase faults demonstrated that the DC connection has the potential to improve wind farm performance during faults in the AC grid.

The wind farm can be quickly isolated from the AC grid and rapidly recovers to full wind power production when the AC grid fault has been restored. It implies that the

converters at both sides of the DC-transmission can stay in operation and connected to the grid, when a fault in the other grid occurs. Thus the requirement of shortest possible interruption in case of faults can optimally be obtained. Testing has shown that the converter station smoothly varies the frequency and that the frequency at the sending end can be controlled solely by the converter station, while the frequency in the receiving end is the AC grid frequency [1], [3].

Troll A

Description of the installation:

Troll A platform is in service since 2005 in Norway, two **HVDC Light** transmission system for 45 MW, +/-60 kV directly feed two high-voltage variable-speed synchronous machines designed for compressor drive with variable frequency and variable voltage with power from land [4]. On the platform equipment will be installed in housings that will be lifted on to the platform. Space and weight have to be kept to a minimum on an offshore installation.

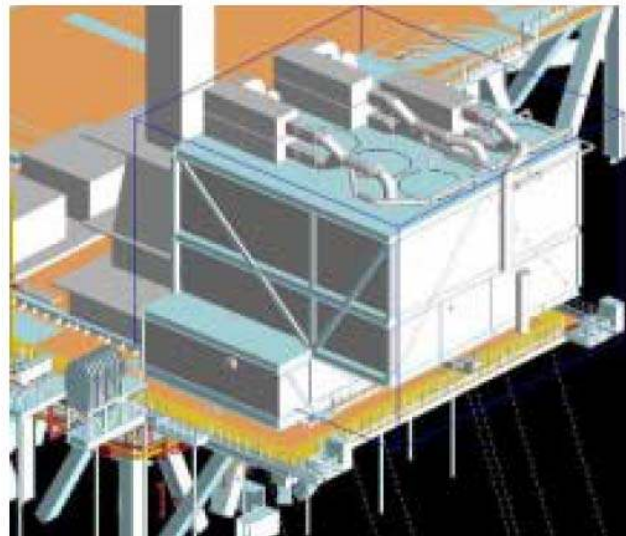

Figure 3. Troll A platform converters 2x45MW.[6]

The HVDC Light concept therefore offers important advantages and thanks to smaller filters than conventional HVDC and no need for additional reactive power generation equipment it can be made compact and lightweight. The layout is kept compact on the platform by placing the converter equipment in a multi-storey module. The HVDC Light offshore converter is planned to be built as a prefabricated unit and transported and installed on top of the platform. The structure will have approximate main dimensions of $W \times L \times H = 18 \times 17 \times 14$ meters [1].

HVDC

Konti-Skan



Description of the installation:

The first interconnection between Sweden and the western grid in Denmark was established in 1965 with the 250 MW Konti-Skan HVDC link across the Kattegatt from Gothenburg to Aalborg. The converter stations were based on mercury-arc valve technology and situated in Stenkullen and Vester Hassing respectively. In 2006 the mercury-arc converters were replaced by thyristor converters.

A second Konti-Skan cable rated 300 MW was added in 1988 from Lindome on the Swedish side to Vester Hassing. Both poles of Konti-Skan have been testing ground for new ABB HVDC developments:

Pole 1:

1973: Second generation thyristor test valve, 135 kV, 1,050 A (air cooled) in Vester Hassing.

1988: Light triggered thyristor (LTT) test valve, 135 kV, 1050 A in Vester Hassing.

1992: The world's first air insulated outdoor thyristor valve, 135 kV, 1,050 A, in Stenkullen.

Pole 2:

1991: The world's first active DC filter in Lindome.

1993: The world's first electronically controlled AC filter ,Contune, in Lindome. [10]

Main data	Pole 1 (decommissioned)	Pole 2
Commissioning year:	1965	1988
Power rating:	250 MW	300 MW
No. of poles:	1	1
AC voltage:	130/150 kV	400 kV (both ends)
DC voltage:	250 kV	300 kV
Length of DC submarine cables:	87 km	88 km
Length of DC overhead line:	86 km	61 km
Main reason for choosing HVDC:	Length of sea crossing	

Skagerrak



Description of the installation:

An electric DC power transmission between Norway and Denmark (using the Thury system) was proposed as early as 1922. But it lasted 54 years until the first 500 MW was realized in 1977. Today the Skagerrak link has three cables: Skagerrak 1&2 with 500 MW (1976-77) and Skagerrak 3 (1993) with 440 MW. The link goes between Kristiansand in southern Norway and Tjele on Denmark's Jutland peninsula.

The converter stations for **Skagerrak 1&2** (1976-77) were the first stations to employ the modern circuitry and station design that is employed even today. The first stations with thyristor valves were designed according to the principles adopted for mercury arc valve stations. But ABB adopted new design principles for the converter stations of the Skagerrak 1&2 link:

- twelve pulse converters
- quadruple thyristor valves
- no 5th or 7th harmonic filters on the AC-side
- converter transformers close to the valve-hall with the valve-side bushings in the valve-hall

The Skagerrak 1&2 link was the first one to employ ABB's second generation of air-cooled valves (which also were used in the CU and Inga-Shaba transmissions).

When **Skagerrak 3** (1993) was built it was decided to reconfigure the existing bipole so that Pole 1 and Pole 2 operate with the same current direction. Thereby achieving a better current balance, since the Pole 3 has a higher current than Pole 1 and 2.

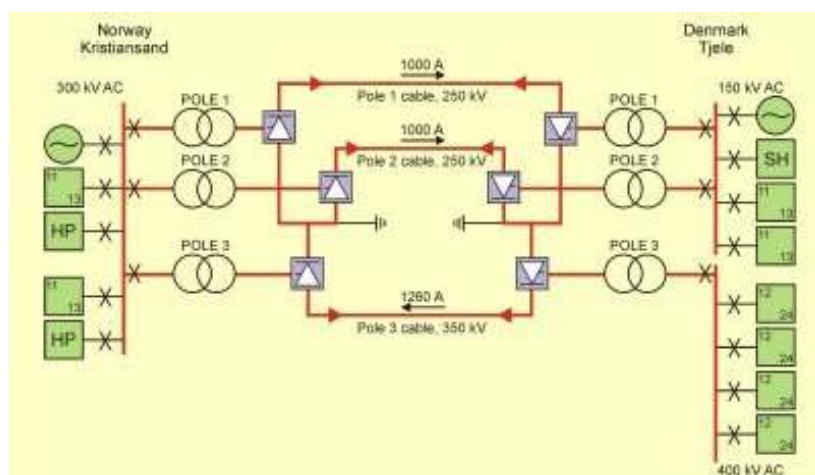

The converter stations of Pole 3 was the first in the series of ABB cable projects during the 1990's that also includes Baltic Cable, Kontek and SwePol [10].

Main data	
Commissioning year:	Pole 1&2: 1976-77 Pole 3: 1993
Power rating:	Pole 1+2: 500 MW Pole 3: 440 MW
No. of poles:	3
AC voltage:	Pole 1&2: 300 kV (Kristiansand), 150 kV (Tjele) Pole 3: 300 kV (Kristiansand), 400 kV (Tjele)
DC voltage:	Pole 1&2: 250 kV Pole 3: 350 kV
Length of DC submarine cables:	127 km
Length of DC overhead line:	113 km
Main reason for choosing HVDC:	Length of sea crossing, asynchronous link.

Sharyland's Cross-border Tie

Description of the installation:

Sharyland Utilities in south Texas is unique in several ways. When it was authorized by the Texas Public Utility Commission in 1999, it became the first greenfield electric utility in the United States since the Reedy Creek Improvement District was created to serve Disney World in the late 1960s. Its south Texas service territory consists of Sharyland Plantation, a 6,000-acre industrial park and real estate development, and all of its customers have automated metering at their premises, measuring usage at 15-minute intervals.

Sharyland is also unique in that it is about to begin construction on an interconnection between the Texas and Mexico power grids that the company says will be the first of its kind to support both emergency power and commercial business activity in Texas and Mexico.

Demonstrating HVDC's ability to connect asynchronous grids, this 150-MW tie will serve to match the electric grids between Texas and Mexico, allowing power to flow in the direction and at the magnitude dictated by the contracting utility. This is one of HVDC's benefits: Power in a DC system is controllable, whereas in an AC system, the laws of physics dictate direction and magnitude of power flow. In this application, the ability to control power flow with HVDC was necessary because of the commercial transactions the tie is expected to support.

3.6 Overview of FACTS

The HVDC tie equipment for the project will be owned and operated by Sharyland Utilities. This particular implementation is what's known as a "back-to-back" HVDC tie, meaning that there is one converter station connecting the two grids. In other HVDC installations, including the two submarine installations discussed later in this article, two converter stations are employed: one to convert AC power to DC and the other, at the other end of the HVDC cable, to convert DC back to AC for delivery to customers. The back-to-back converter station, which serves to match the asynchronous Mexican and U.S. power systems, will be located in Mission, Texas, with transmission lines connecting facilities in Reynosa, Tamaulipas, Mexico.

Construction on the Sharyland tie is expected to begin by mid-2006 with commercial operations supported by about August 2007. Sharyland Utilities has contracted with American Electric Power's T&D Services department to provide project management and transmission system design. AEP T&D Services will oversee the design and operational requirements of the project and coordinate construction of the site with the HVDC vendor, ABB.

As a non-merchant facility, the line will be available to all Texas interconnected energy providers as an "open access tie." Mark Caskey, Sharyland's general manager, explained that the Electric Reliability Council of Texas (ERCOT) will coordinate open-access operations of the tie when it is completed, and the Public Utilities Commission of Texas (PUCT) will regulate electrical transmission rates. Caskey noted that the DC Tie will be open to all generators and retail electric providers in ERCOT and Mexico, and they will negotiate actual energy prices at open-market rates in accordance with the open-access operational standards developed by ERCOT. The PUCT will regulate pricing for transmission of that power.

The HVDC tie will also provide black start capability, an important reliability-enhancing feature in which normal operations can be suspended and a safe flow of power provided to help restore affected areas.

Caskey said the HVDC tie with Mexico is an investment meant to support not only power reliability but also future economic growth in the area Sharyland Utilities serves. "Many Fortune 500 executives are surprised by the financial impact a power outage has on their businesses," he said. "With this HVDC tie, we are ensuring that state-of-the-art electrical infrastructure will be available for the critical operations at those businesses that choose to relocate to Texas." [11]

SVC

Radsted

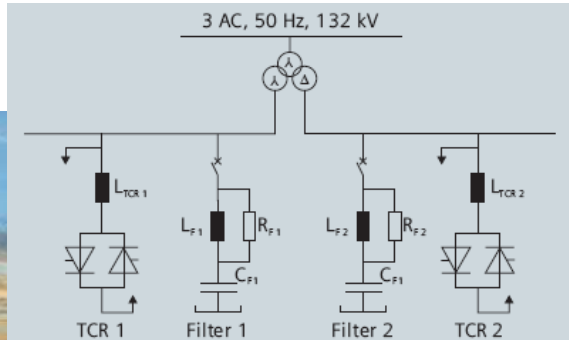

Customer	SEAS-NVE, Denmark
System Voltage	132 kV/ 50 Hz
Transformer	3-winding type
Operating range	+80.2 MVar (capacitive) to -65 MVar (inductive)
Definition of SVC Branch circuits	12-pulse configuration 2 x TCR 2 x Filters
Thyristor	125 mm Ø, 4 kA, 8 kV
Filter frequencies (harmonics)	550 Hz (11th)
Valve type	8 kV light-triggered-thyristor
Valve cooling system	Double-circuit with de-ionized water/water glycol mixture
Digital control system	SIMATIC TDC®

Description of the installation:

SEAS-NVE, the largest utility in Denmark operates the Nysted Offshore Windpark located south of the island of Lolland. Voltage fluctuations caused by this facility lead to voltage stability problems in the 132 kV transmission system. In June 2005, Siemens was awarded a turnkey project for the construction of an SVC located on the island of Lolland. It provides the necessary reactive power balance for the system, helps to improve voltage quality and increases system stability. Siemens offered a special solution for this project: the SVC has a 12-pulse configuration consisting of a TCR (Thyristor Controlled Reactor) and a filter in each of the two secondary circuits of the 3-winding step-down power transformer. One of the transformer’s secondary winding is connected in star, while the other is connected in delta. The delivered high-pass filters are tuned to the 11th harmonic and are connected in star. The 12-pulse configuration has the advantage that due to the phase shift in the two secondary busbars of the SVC, the 5th, 7th, 17th and 19th harmonics produced by each of the TCR branches cancel each other out, helping to meet the stringent harmonic requirements. Furthermore Siemens took special care to fulfill the customer’s

requirements in terms of noise reduction and architectural appearance. Therefore, the SVC was completely housed in a “barn-type” building equipped with special sound muffling materials and components. The buildings height was kept below 6 meters, made possible by optimizing the equipment configuration inside [5].

Starfish Hill

Description of the installation:

The Starfish Hill wind farm was commissioned in 2003. It is located near Cape Jervis on the Fleurieu Peninsula. The wind farm comprises 23 turbines producing 34.5 MW, and a 25 km. overhead transmission line to connect the wind farm to the ETSA Utilities electricity distribution network at Yankalilla.

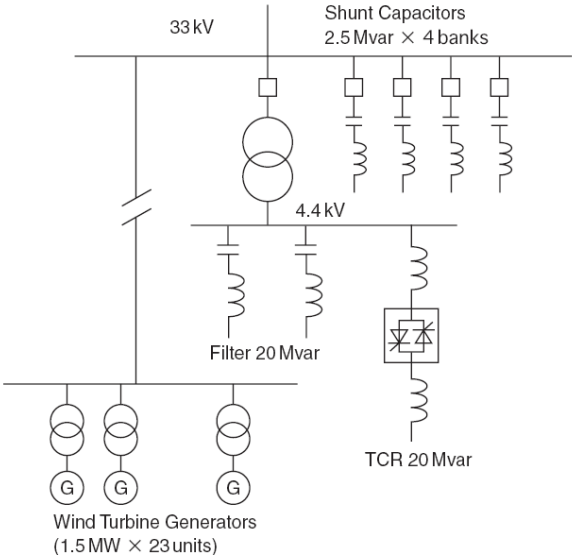

Figure 4. Starfish Hill SVC single line diagram (left), and Cape Jervis Substation ETSA Utilities South Australia (right).[9]

Rating	20 Mvar with 10 Mvar Shunt Capacitor Banks
AC System Voltage	33kV-ac (50 Hz)
Converter Valve	Air Cooled, Air insulated anti-parallel valve
Ratings of Thyristor	6 kV- 2500 A ETT(4 inches)
Number of Thyristors	18
Controller	32-bit direct digital controller

Figure 5. Data of the SVC.[9]

STATCOM

Stony Hill and Bates Rock

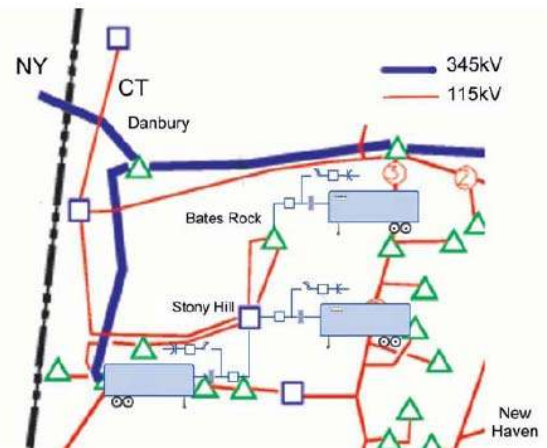

Description of the installation and the problem:

In several parts of New England, local transmission constraints limit power flow either from points of generation or to points of load. Currently, that part of Connecticut is served by 115kV lines. A proposed 345kV upgrade is several years away at least, since it must go through regulatory approval, engineering and construction. During the Summer of 2002, demand became so high that the local utilities were just one fault away from load-shedding. They identified both system low voltages and potential voltage instability problems due to a number of potential contingency events in the area. Less expensive imports of electricity could not be used without compromising transmission system reliability. The area could not accommodate more local generation due to the very high fault power already available. The objective of the study was to determine how to increase the safe transfer of at least 100MW of incremental power into SWCT. The Stony Hill, Bates Rock and West Brookfield substations experienced their worst post-contingency voltage problems during high transfer conditions that defined the limitations on the 115kV lines. In the wake of some contingencies, studies indicated that voltage would potentially go into immediate collapse, without recovery. Accordingly, the need for support from STATCOMs system was obvious. To have the necessary effect, any solution would have to be able to react instantaneously to voltage events and ideally would also leverage existing distribution transformers. In addition, it would have to be "intelligent" enough to allow simultaneous control of both transmission and distribution voltages. To make matters more challenging, there was little physical room in any of the local substations to accommodate large equipment.

Solution and benefits:

The selected configuration:

- Stony Hill — two 8MVAR D-VAR systems, each controlling a 37.8MVAR switched 115kV capacitor. The D-VAR system responds to voltages on the 115kV lines, but also senses the 13.8kV distribution bus to prevent over voltages.
- Bates Rock — one 8MVAR D-VAR system controlling an 8.7MVAR switched 13.8kV capacitor, with the same sensing and over voltage protection. The specific control points for capacitor “turnon/ turn-off,” inverter initiation voltage, rates of inverter response, time delays and other output settings were defined in joint discussions between all stakeholders.

ISO-NE and Northeast Utilities have determined that the installation of the D-VAR systems at Stony Hill and Bates Rock increased SWCT’s import capacity by 100MW. This innovative solution has increased the amount of load that can be served over existing transmission lines in SWCT without compromising system integrity. In addition, significant congestion costs have been avoided in subsequent years [12].

Holly

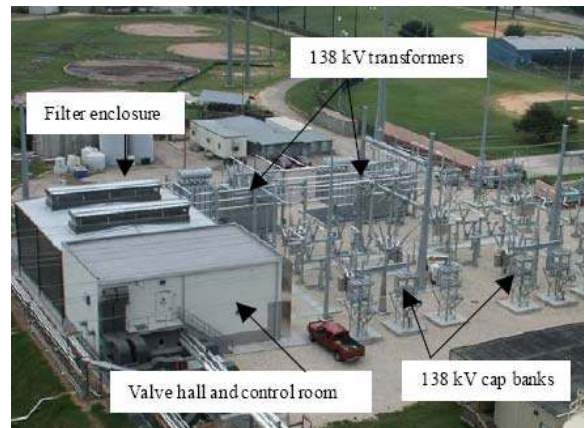
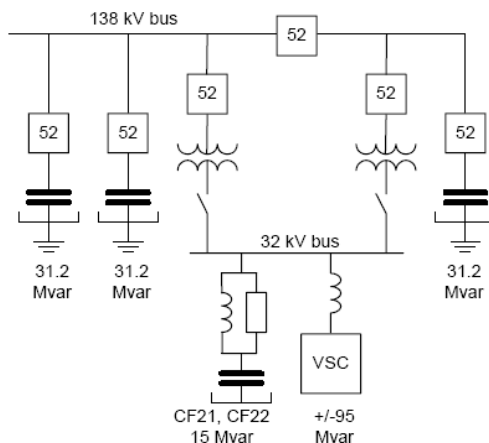

Description of the installation:

The power plant to be retired is located on Holly Street near downtown Austin. The STATCOM is partially built on top of a reinforced old oil tank near the Holly power plant, at the Pedernales substation. The STATCOM consists of a VSC inherently symmetrically rated at +/- 95 MVA and 15 Mvar of filters seen from the Pedernales 138 kV bus. In total this gives an operating range from 80 Mvar inductive reactive power to 110 Mvar capacitive reactive power. There are also the three 138 kV capacitor banks each rated at 31.2 Mvar for providing steady-state reactive power support to the grid. Including the three 138 kV capacitor banks, the reactive power range is 80 Mvar inductive to just above 200 Mvar capacitive. The dynamic portion of this is two times the VSC rating of 95 Mvar, or 190 Mvar [14].

APENDIX

Series compensators.

The variable series compensation is highly effective in both controlling power flow in the line and in improving stability. With series compensation the overall effective series transmission impedance from the sending end to the receiving end can be arbitrarily decreased thereby influencing the power flow.

$$P = \frac{V^2}{X} \sin \delta$$

This capability to control power flow can effectively be used to increase the transient stability limit and to provide power oscillation damping. The different types of series compensation devices are:

- Thyristor-Switched Series Capacitor (TSSC) The basic element of a TSSC is a capacitor shunted by bypass valve. It is inserted into the line if the corresponding thyristor valve is turned off, otherwise it is bypassed.

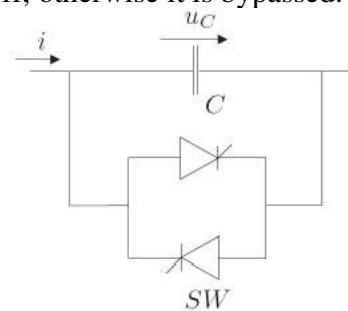

Figure 1: Electrical scheme of TSSC

- Thyristor-Controlled Series Capacitor (TCSC) It is a capacitive reactance compensator which consists of a series capacitor bank shunted by a thyristor-controlled reactor in order to provide a smoothly variable series capacitive reactance.

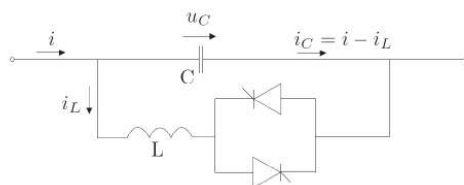

Figure 2: Electrical scheme of TCSC

- GTO Thyristor-Controlled Series Capacitor (GCSC) An elementary GTO Thyristor-Controlled Series Capacitor consists of a fixed capacitor with a GTO thyristor valve that has the capability to turn on and off upon command. The objective of the GCSC scheme is to control the AC voltage u_c across the capacitor at a given line current i .

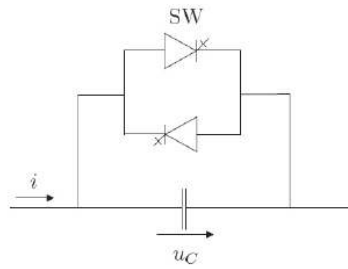

Figure 3: Electrical scheme of GCSC

- **Static Synchronous Series Compensator (SSSC)** It is a static synchronous generator operated without an external electric energy source as a series compensator for the purpose of increasing or decreasing the overall reactive voltage drop across the line and thereby controlling the transmitted electric power. The SSSC may include transiently rated energy storage or energy absorbing devices to enhance the dynamic behaviour of the power system by additional temporary active power compensation, to increase or decrease momentarily, the overall active (resistive) voltage drop across the line.

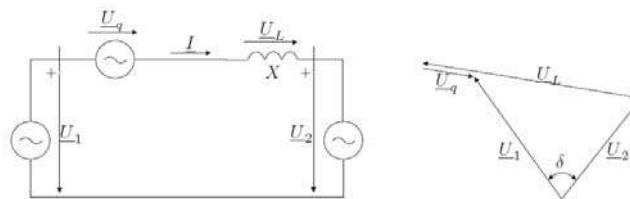

Figure 4: Electrical scheme of SSSC

- **Phase Angle Regulator (PAR)** Phase Angle Regulators are able to solve problems referred to the transmission angle which cannot be handled by the other series compensators. These regulators are based on the tap changing transformers.

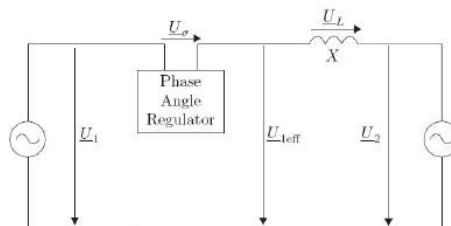

Figure 5: Electrical scheme of PAR

The SSSC is a voltage source type and the TSSC, TCSC and GCSC are variable impedance type series compensators. Resulting from the different structures there are essential differences in characteristics and features of these devices:

The SSSC is capable of internally generating a controllable compensating voltage over an identical capacitive and inductive range independently of the magnitude of the line current. The compensating voltage of the GCSC and TSSC over a given control range is proportional to the line current. The TCSC can maintain maximum compensating voltage

with decreasing line current over a control range determined by the current boosting capability of the thyristor controlled reactor.

The SSSC has the ability to interface with an external DC power supply to provide compensation for the line resistance by the injection of active power as well as for the line reactance by the injection of reactive power. The variable impedance type series compensators cannot exchange active power with the transmission line and can only provide reactive compensation.

The SSSC with energy storage increases the effectiveness of power oscillation damping by modulating the series reactive compensation to increase and decrease the transmitted power and by concurrently injecting an alternating virtual positive and negative real impedance to absorb and supply active power from the line in sympathy with the prevalent machine swings. The variable impedance type compensators can damp power oscillation only by modulated reactive compensation affecting the transmitted power.

Series reactive compensation can be highly effective in controlling power flow in the line and in improving the dynamic behaviour of the power system. But certain problems related to the transmission angle cannot be handled by series compensation. For example, the prevailing transmission angle may not be compatible with the transmission requirements of a given line or it may vary with daily or seasonal system loads over too large a range to maintain acceptable power flow in some affected lines. To solve these problems, phase angle regulators (PAR) or phase shifting transformers (PST) are employed.

Shunt compensators.

Shunt compensation is used to influence the natural electrical characteristics of the transmission line to increase the steady-state transmittable power and to control the voltage profile along the line. As static shunt compensators are known Static Var Compensators (SVC) and Static Synchronous Compensators (STATCOM).

The different types of shunt compensation devices are:

Static Var Compensator (SVC): A shunt-connected static var generator or absorber whose output is adjusted to exchange capacitive or inductive current so as to maintain or control specific parameters of the electrical power system (typically bus voltage).

- Thyristor-Controlled and Thyristor-Switched Reactor (TCR and TSR)
 TCR: A shunt-connected, thyristor-controlled inductor whose effective reactance is varied in a continuous manner by partial-conduction control of the thyristor value.
 TSR: A shunt-connected, thyristor-switched inductor whose effective reactance is varied in a stepwise manner by full or zero conduction operation of the thyristor value.

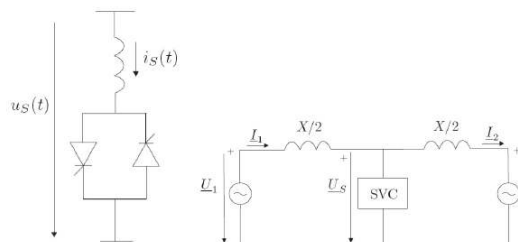

Figure 6: Electrical scheme and location of TCR and TSR

- Thyristor-Switched Capacitor (TSC) A shunt-connected, thyristor-switched capacitor whose effective reactance is varied in a stepwise manner by full or zero conduction operation of the thyristor value.

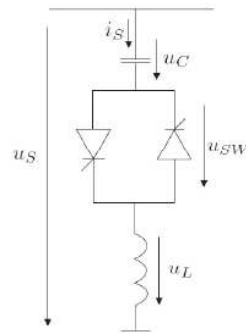

Figure 7: Electrical scheme of TSC

STATCOM: A static synchronous generator operated as a shunt-connected static var compensator whose capacitive or inductive output current can be controlled independent of the AC system voltage. A STATCOM is a controlled reactive-power source. It provides voltage support by generating or absorbing reactive power at the point of common coupling without the need of large external reactors or capacitor banks.

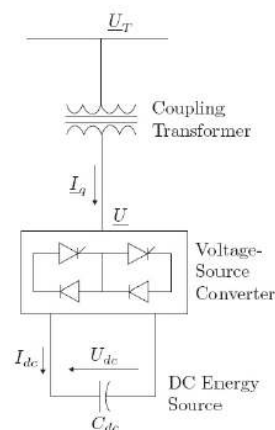

Figure 8: Electrical scheme of STATCOM

SVC and STATCOM are very similar in their functional compensation capability, but the basic operating principles are fundamentally different. A STATCOM functions as a shunt-connected synchronous voltage source whereas a SVC operates as a shunt-connected, controlled reactive admittance.

Combined compensators.

The series-connected controllers impact the driving voltage and hence the current and power flow directly. Therefore, if the purpose of the application is to control the current/power flow and damp oscillations, the series controllers are more powerful than the shunt controllers.

The shunt controllers are like current sources. They draw from or inject current into the line. Thus, shunt controllers are applied to control voltage at and around the point of connection through injection of reactive current. Because STATCOMs have the capability to inject active as well as reactive current they are able to provide an even more effective voltage control and damping of voltage oscillations.

This does not mean that the series controllers cannot be used for voltage control. Because the voltage fluctuations are largely a consequence of the voltage drop in series impedances of lines, transformers and generators, inserting a series compensator might be the most cost-effective way of improving the voltage profile. Nevertheless, a shunt controller is much more effective in maintaining a required voltage profile at a substation bus. That is because the shunt controller serves the bus node independently of the individual lines connected to the bus.

- Unified Power Flow Controller (UPFC): A combination of static synchronous compensator (STATCOM) and a static series compensator (SSSC) which are coupled via a common dc link, to allow bidirectional flow of active power between the series output terminals of the SSSC and the shunt output terminals of the STATCOM, and are controlled to provide concurrent active and reactive series line compensation without an external electric energy source. The UPFC, by means of angularly unconstrained series voltage injection, is able to control, concurrently or selectively, the transmission line voltage, impedance, and angle or, alternatively, the active and reactive power flow in the line. The UPFC may also provide independently controllable shunt reactive compensation.

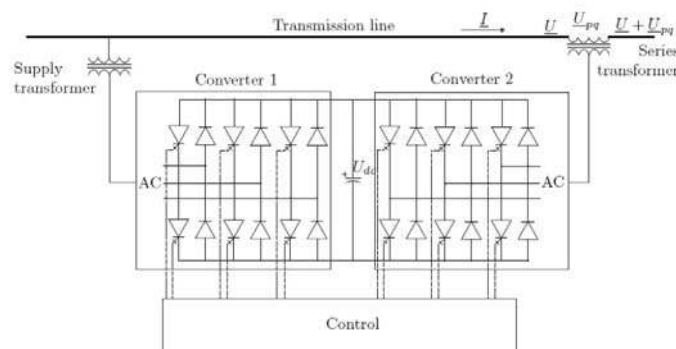

Figure 9: Electrical scheme of UPFC

- Interline Power Flow Controller (IPFC): The combination of two or more Static Synchronous Series Compensators which are coupled via a common dc link to

facilitate bi-directional flow of active power between the ac terminals of the SSSCs, and are controlled to provide independent reactive compensation for the adjustment of active power flow in each line and maintain the desired distribution of reactive power flow among the lines.

The IPFC structure may also include a STATCOM, coupled to the IPFC's common dc link, to provide shunt reactive compensation and supply or absorb the overall active power deficit of the combined SSSC's.

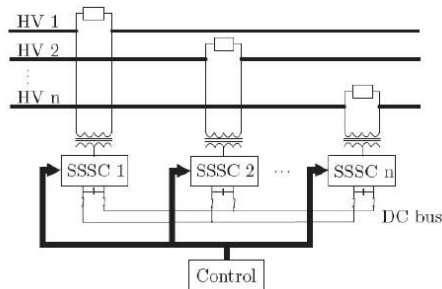

Figure 10: Electrical scheme of IPFC

High Voltage Direct Current transmission (HVDC)

Another option to control power flow is High-Voltage Direct-Current transmission (HVDC). HVDC devices convert AC to DC, transport it over a DC line and then convert DC back to AC. This has advantages over AC transmission in several applications:

- Underwater cables: Cables have a large capacitance. For AC cables this results in a high charging current. If the cable is longer than about 50-60 kilometers the charging currents will fully load the cable and no real power transmission is possible. A solution to the problem would be to place shunt inductors every 50 kilometers. But to do so, land is required. DC cables do not have these drawbacks.
- AC system connection: To connect two AC systems of different frequencies, the power from one system can be converted to DC power, transported over the DC line and then fed into the other AC system with different frequency. Also, not synchronized networks can be connected like this.
- Long distance overhead transmission: If the transmission line is long the savings in line capital costs and losses with a DC line may countervail the investment costs for two converters and therefore a HVDC may be more favourable.

Use of FACTS

The application of these devices depends on the problem which has to be solved. In Table an overview of problems occurring in the grid and which FACTS to be used to solve these problems are given.

Subject	Problem	Corrective action	FACTS
Voltage limits	Low voltage at heavy load	Supply reactive power	SVC, STAT-COM
		Reduce line reactance	TCSC
	High voltage at low load	Absorb reactive power	SVC, STAT-COM
	High voltage following an outage	Absorb reactive power, prevent overload	SVC, STAT-COM
	Low voltage following an outage	Supply reactive power, prevent overload	SVC, STAT-COM
Thermal limits	Transmission circuit overload	Increase transmission capacity	TCSC, SSSC, UPFC
Load flow	Power distribution on parallel lines	Adjust line reactances	TCSC, SSSC, UPFC
		Adjust phase angle	UPFC, SSSC, PAR
	Load flow reversal	Adjust phase angle	UPFC, SSSC, PAR
Short circuit power	High short circuit current	Limitation of short circuit current	TCSC, UPFC
Stability	Limited transmission power	Decrease line reactance	TCSC, SSSC

Table 1: Examples of use for FACTS

Reference [15]

References

1. K. Eriksson, P. Halvarsson, D. Wensky, M. Häusler: System approach on designing an offshore windpower grid connection. ABB Utilities.
2. Axelsson U, Holm A, Liljegren C, Åberg M, Eriksson K, Tollerz O: The Gotland HVDC Light project – experiences from trial and commercial operation; CIRED 2001, Amsterdam, Netherlands, June 2001.
3. Soebrink K, Soerensen A, Jensen J, Holmberg P, Eriksson K, Skytt A-K: Large-scale offshore wind power integration and HVDC using Voltage Sourced Converter; Cigre Fourth Southern Africa regional conference, Cape Town, South Africa, October 2001.
4. Hörle N, Eriksson K, Maeland A, Nestli T: Electrical supply for offshore installations made possible by use of VSC technology; Cigre 2002 Conference, Paris, August 2002.
5. FACTS – Flexible AC Transmission Systems. Static Var Compensators. Siemens AG, Power Transmission and Distribution, High Voltage Division.
6. K. Eriksson, C. Liljegren, K. Sobrink: HVDC Light Experiences applicable for power transmission from offshore wind power parks.
7. ABB AB Grid Systems – HVDC: Connecting wind farms by HVDC Light.
8. A. Skytt, P. Holmberg, L. Juhlin : HVDC Light for connection of wind farms; Presented at Second International Workshop on Transmission Networks for Offshore Wind Farms Royal Institute of Technology Stockholm, Sweden, March 29-30, 2001
9. Mitsubishi electric power products, inc.
http://72.22.2.231/mepssd/NPDF3/SVC_StarFish.pdf
10. ABB HVDC Reference Projects in Europe.
<http://www.abb.com/cawp/gad02181/c1256d71001e0037c1256c330030750d.aspx>
11. HVDC applications. Siemens Power Transmission & Distribution, Inc.
http://w1.siemens.com/pool/en/whats_new/features/power/hdvc_applications_uael_and_p_hvdc.pdf
12. Case Study. American Superconductor.
http://www.amsc.com/products/powerquality/documents/SH_CS_0108_A4_FNL.pdf

13. ©2008 American Superconductor.
<http://www.amsc.com/products/applications/windEnergy/index.html>
14. A. Oskoui, B. Mathew, M. Oliveira, T. Larsson, Å. Petersson, E. John. Holly STATCOM – FACTS to replace critical generation, operational experience.
[http://library.abb.com/GLOBAL/SCOT/scot221.nsf/VerityDisplay/8A28C6DFA26F2619C125714800400E50/\\$File/IEEE%20San%20Antonio%20USA%202005%20.pdf](http://library.abb.com/GLOBAL/SCOT/scot221.nsf/VerityDisplay/8A28C6DFA26F2619C125714800400E50/$File/IEEE%20San%20Antonio%20USA%202005%20.pdf)
15. Gabriela Glanzmann. FACTS Flexible Alternating Current Transmission Systems.
14. January 2005, Zürich

Contacts

Remus Teodorescu, ret@iet.aau.dk.

4 Market Measures

To use commercial markets to balance the electricity system is a relatively new approach. Ten years ago the spot market was not introduced in Denmark. Today it is the dominating market for electricity. The Nordic electricity market is successful in many ways, e.g.:

- The Nordic spot market traded 292 TWh in 2007 (69% of the total demand). In 1/3 of the hours the spot price is the same in all Nordic countries. In the rest of the time one or more transmission lines are congested. Demand and generation are traded equally in the spot market. All transmission lines among the Nordic countries are managed by the spot market,
- Extensive trade take place with continental countries (Russia, Poland, Germany, Estonia, and with the new NorNed also with the Netherlands)
- Regulating power is continuously traded among the Nordic countries. The cost of regulating power is often close to the spot price and compared to other areas regulating power is low. Effective use of the Norwegian and Swedish Hydro power is part of the background for this result.
- The market has proven to effectively deal with challenging situations, like the lack of hydro power (in the winter 2002/2003), the lack of nuclear power (in xx) as well as dealing with the fluctuating 3,000 MW wind power.

The high level of wind power from Denmark is to a large extent integrated in the electricity system through the commercial market. Wind power and hydro power work together based on the coordination the spot market offer. Combined with (generally) low cost regulating power wind is efficiently integrated in today's electricity system.

However, doubling the wind power (in Denmark and other countries) would challenge the current market systems. Many aspects of the market set-up have been under continuous development the last years, and this process is likely to continue. Many aspects of the current market set-up have historical traces from a time where little wind power existed and where electricity was sent one-way from central power stations to the end-users. In the future many new actors can be anticipated and the market system should be developed accordingly.

The design of the market is crucial for optimal use of existing capital in power plants and transmission lines.

In this text important potential changes in the market system will be highlighted. The economical success of such changes is mostly dependent of the degree that the changes will bring a more efficient dispatch of generation. A market set-up that excludes some potential market actors is less efficient than a system where all potential sources can be utilised. The barriers against new market set-up is in general not the cost of the needed IT systems, but the fact that several organisations must agree, e.g. all Nordic TSO's or the UCTE system. Since the challenges are different in the different countries only market systems with a high degree of universality can be expected to be successful.

Near real time markets

Today's most important market is the spot market. This is a day-ahead market where traders exchange bids about generation and demand for each hour for next day. The regulating power

market (which includes both up and down regulation) has a much smaller volume and is traded with a 15 minutes notice. To be part of the regulating power market a supplier must send in plans and guarantee to be able to supply the service. The service is controlled by real time meters and a minimum bid size of 10 MW is applied. Combined these two markets (spot market and regulating power) is a sort of a near real time market.

The competition in the regulating power market is limited (occasionally leading to very high and low prices, e.g. negative prices) and many potential suppliers are in practise prevented from being active in the regulating power market.

A future possibility is to create a near real time power market based on an online price signal and without the first steps in the present system for regulating power market: Reservation of availability (which is often used in Denmark) and the exchange of bids. Furthermore the real-time measurements can be avoided. The procedure could take the following form:

- The spot market is used as today to plan the hourly balance for next day.
- Regulating power is activated by offering an “adderr” to the spot price. The TSO could change the adderr, e.g. each five minutes. If the system could be run as planned in the spot market, then the adderr would be 0. If more generation (or less demand) was needed to obtain a secure operation, then the adderr could be positive. And vice versa. All market players (demand and generation) could choose to be exposed to the adderr. All needed is interval meters (five minutes) and broadcast of the actual price added per area.

With such system all potential suppliers could increase and decrease their generation and demand according to the actual price. New potential suppliers could include electricity demand and micro generation. Also wind power and de-central CHP could react to prices. For wind power to act according to its marginal cost, the subsidy system should be revised so subsidy was not given according to production (same changes as has been implemented for CHPs).

For the system to be successful the TSO should have confidence in that there always would be sufficient suppliers. Practical experience could form the basis of relevant price steps. Historical results could indicate what size the adderr should have to obtain the needed regulation. New statistical procedures should be developed for monitoring the amount of regulating power.

In this text only the spot market and regulating power is deals with. However, the same idea could be developed to include ancillary services.

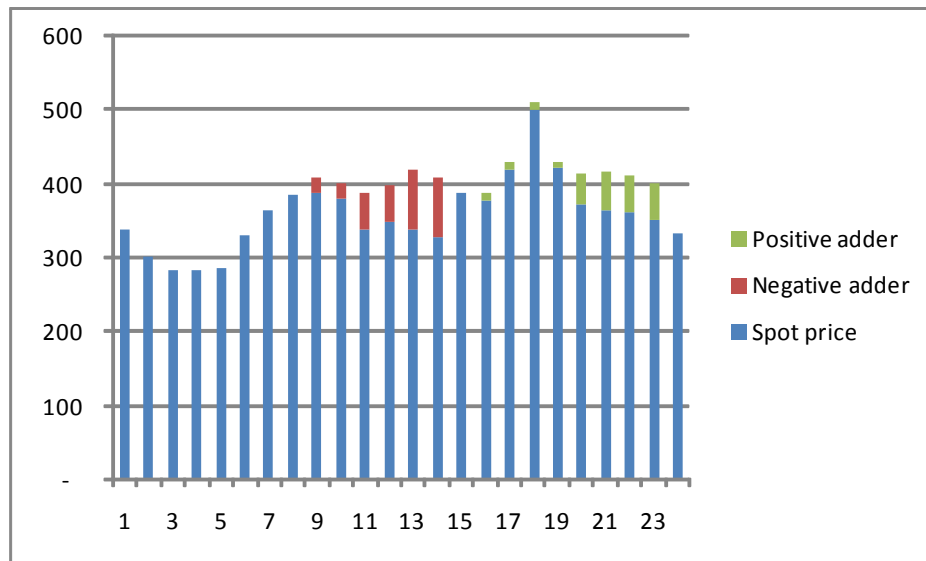

Figure 1. Illustration of a near real time market. In this example the spot price is reduced in the hours 9 to 13 (demand for up regulation), and increased in the hours 15 to 23 (demand for down regulation).

Dynamic pricing

Several issues in the current market are dampening the price volatility. This is a loss of efficiency since real high or low marginal costs are not signalled to the market players. There is a chicken and egg situation; Simplified tariffs are used because few market players were interested in a varying price. With no or little price variation few market players will react.

Several services are currently paid for with tariffs that do not signal the dynamic nature of the cost. One example is the costs associated with losses. The costs of losses are not included in the spot market. This helps simplify the market, but will in some cases lead to too long transport of electricity. Losses in the transmission system are paid by the TSO and the used tariffs are typically constants, despite the fact that the losses vary a lot. The losses are highly dependent of the load of the cables. The relationship between load in a cable and the losses is quadratic; a doubling of power flow will increase the losses by a factor four. Dynamic pricing of losses can also be relevant in the distribution grid (where most losses occur).

The design of the spot market also include features that are dampening the true price signals: By using large price areas instead of nodal pricing, prices will show less variation. Less price variation means less efficient dispatch.

New ancillary service markets

The idea of a market for ancillary services as a new measure is to activate other costumers than the central power plants to provide the necessary ancillary services. The main focus is on services for frequency control / power balancing and for voltage control / reactive power, but also black start capabilities can be considered. The costumers that can participate in an ancillary service market are first of all the remaining central power plants and the decentralised power plants including wind power plants. But also the demand side can participate, especially in the real-power balancing.

The market for ancillary services must take into account that the new sources such as decentralised power plants are not continuously online. A market which is close to real time can ensure that the ancillary services are provided by sources which are already online, and thus it can be avoided to run units only to ensure ancillary services.

Demand response

Electricity demand played an important role in the dry winter 2002/2003. In Norway electricity demand was reduced with more than 1,000 MW in December 2002 – when spot prices were at their highest. Industrial facilities, e.g. from energy intensive industry are used to optimize production in relation to spot prices.

A challenge is to activate other resources than the few energy intensive industries. Development in electronics for communication and control makes it continuously more likely that small electricity demand can be included. Several projects have demonstrated that electric heating can be used as demand response – with limited impact for the users.

As described above several features of the current electricity market is dampening price variations. And the potential economic benefit of demand response is proportional to price variation. More wind power combined with an active policy to deliver true price signals (instead of dampening variation) could increase the incentive for demand response dramatically.

Several studies have described the practical potential for demand response in Denmark, see table 1.

	excl. electric heating	Electric heating
Non-residential () ¹	385 MW	270 MW
Households ²	100 MW	187 MW
Back-up generation ³	350 MW	-
	836 MW	457 MW
Total	1,290 MW	

Table 1. Estimated potential for demand response in Denmark

- 1) Dansk Energi Analyse and Norenergi (2005)
- 2) Energistyrelsen (2006)
- 3) Elkraft System (2003) and Ea Energy Analyses (2008)

Taxes are an important part of the total electricity cost in Denmark. Taxes are all constant tariffs. Time variation in taxes or a design as VAT (dependent of values) would increase the incentive for demand response.

4.0 Overview of Current Nordic Electricity Market

The Nordic electricity market year 2008 is well working, wherefore, the market concept is spreading around Europe, but the system is far from perfect. The day-ahead market is well-established working equally for all the participating countries. For the balancing markets the case is not the same with different rules and practices in the different countries. Nordel (Organization for the Nordic Transmission System Operators) is trying to promote the establishment of a seamless Nordic electricity market as an integrated part of the North-West European electricity market and to maintain a high level of security in the Nordic power system, which also includes some level of harmonization between the countries.

Commercial Markets

Day-ahead market

The most important market is the spot market where $\frac{3}{4}$ of all electricity is traded. The spot market is a day-ahead market where bids concerning demand and generation is exchanged, and form the basis for hourly prices. An important market design feature is that congestion is (mainly) dealt with by market splitting: If a transmission line is fully used the market will calculate different prices on the two sides on the line. Transmission lines between the Nordic countries are managed by the spot market, based on capacities allocated to the market by the TSOs.

Bilateral trade is allowed, but can only take place within price areas. If an actor wishes to trade electricity across price areas, the transaction must take place via the spot market. Bilateral trade account for $\frac{1}{4}$ of all traded electricity.

Several graphs can illustrate the spot market. See below. The first graph shows the average yearly price for the two Danish price areas. The next five graphs illustrate in different ways that the competition in general is quite intense: In $\frac{1}{3}$ of the time there is no congestion between Denmark, Sweden, Norway and Finland. In these periods all the producers in this large area compete about delivering power. In the $\frac{2}{3}$ of the time one or more congestions exist and competition take place in smaller areas. The high level of competition can also be illustrated by the fact the extreme high prices are seldom (in average prices are above 100€/MWh in 1% of the time). Similar very low prices are seldom. Low prices can occur in Denmark when congestion exists and when a large amount of local must-produce exist, e.g. wind power as well as conventional power plants. Typical less than 2% of the prices is below 10€/MWh.

4.0 Overview of Current Nordic Electricity Market

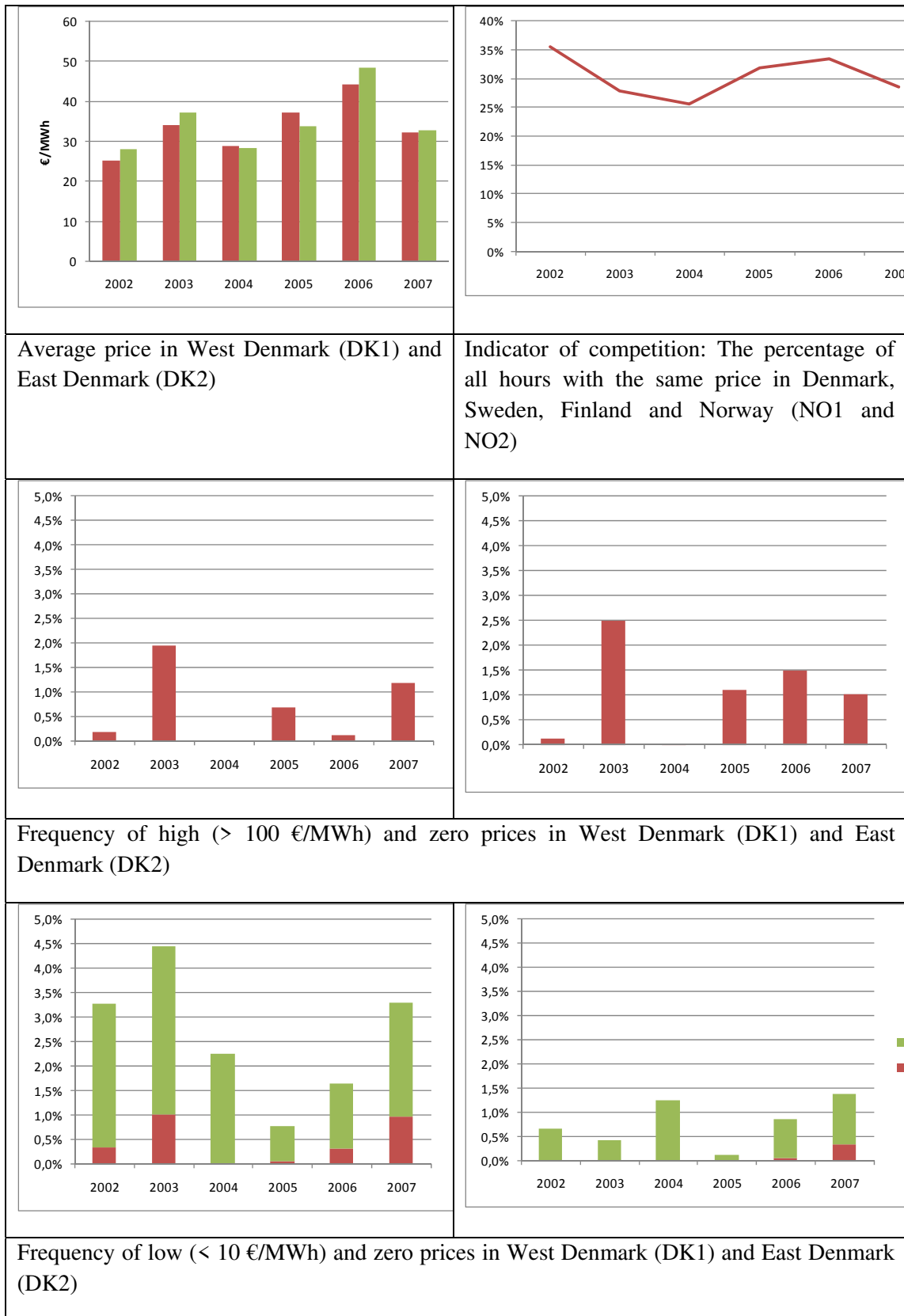

Figure 1. Prices from Nord Pool spot market

4.0 Overview of Current Nordic Electricity Market

The TSO's have a central role in allocating transmission capacity to the market. This monopoly activity often reduced the available transmission capacity. This practice include reduction of import/export capacity to obtain internal benefit, e.g., to control flow on an internal transmission line. From March 2007 the TSOs have started to publish information about why transmission capacity has been reduced. See table 1.

Table 1. Codes for transmission capacities allocated to the market. 30% of time the capacity is reduced (more than 100 MW). 17% of the time a reduction takes place due to internal conditions in the price area. See further details in appendix 1. 12 March – 2 December 2007.

Normal capacity (+/- 100 MW)	70.2%
Reduced capacity/Reasons at the transmission line	11.5%
Reduced capacity/Reasons internal in the price area	17.0%
Reduced capacity/Other reasons	1.3%

The current price areas follow the national borders and do not always follows the actual lines with congestions, e.g., Sweden is maintained as one price area. Denmark and Norway are subdivided in several price areas (Denmark 2 areas, Norway from two to four areas). Congestions that are deemed to be temporal (not structural) are often not dealt with by new price areas, but are managed by counter trade. With counter trade the TSOs accept a market solution in the day-ahead market that is not actual possible. Thereafter, the TSO buy and sell electricity at different locations to make the power flow acceptable. This is a type of correction of the market solution. Conflicting arguments are used in this discussion. E.g., some argue that large price areas are needed to maintain a strong competition. See Svenska Kraftnät et al. (2007) and Ea Energy Analyses and COWI (2007).

Hour-ahead marked

It is possible to correct the amount of electricity bought or sold on bilateral or spot market until one hour before the operating hour. This can be done in the Elbas market. While, in the order of 40,000 MW is traded in the spot market, only 100 to 1,000 MW is traded in Elbas. However, the volume is increasing (see figure 2) and when Norway enters the market in 2008 – as the last Nordic country – the volume is expected to increase further. Some think that the Elbas market is not used more, because the regulating power has an attractive (low) price. The Elbas volume can be compared to typical volumes for regulating power in West and East Denmark of 150 and 65 MW.

Figure 2: Volume trade in Elbas. Hourly data from 1st January 31th December 2007. A 200 hours running average is included in the graph

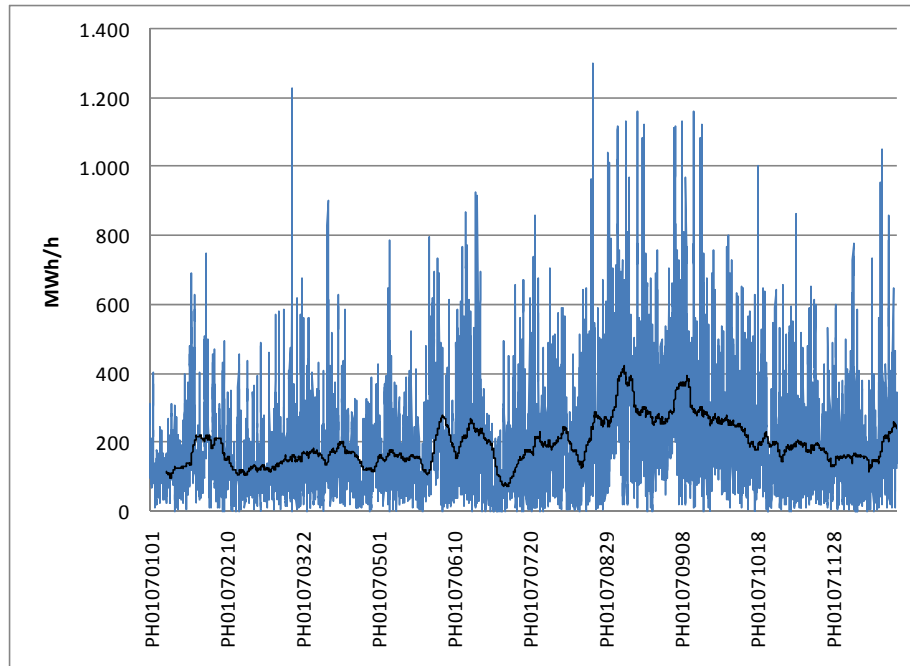

The Nordic commercial markets are energy-only markets. In other markets, e.g., in USA these markets are combined capacity and energy markets.

Wind power is sold on the commercial market. This is done by the TSO or by commercial balance responsible. Whether the TSO has a role is related to the age of the wind mill and the corresponding subsidy scheme. In any case the predicted wind power is sold on the spot market – typically as a price independent bid (must-produce).

The commercial trades (bilateral, Nord Pool Spot and Nord Pool Elbas) result in plans for demand and generation for each hour. Each balance responsible must create and report such plans. The TSO has the task of checking these plans. This includes monitoring of the resulting power flows and evaluating whether all situations are safe.

The commercial markets are mainly about establishing an energy balance per hour. A plan where demand and generation is in balance hourly will secure the normal frequency in the system as seen over the hour (but not within the hour). Other parameters, like voltage and short circuit current, are only dealt with by the TSOs restriction on transmission capacities and the TSOs actions e.g. with must-produce-contracts for selected central power plants.

Ancillary Services

To maintain a secure electricity system more than the plans for hourly energy balance must exist. Ancillary service is the title used to deliver the needed services. The services can be divided into:

- Frequency
 - Automatic reserves to counter act intra hour unbalances

- Normal reserves (2-3 minutes notice)
- Disturbance reserves (5-30 seconds notice)
- Manual reserves to re-establish the automatic reserves (typically 15 minutes notice)
 - Regulating power (mostly for unbalances)
 - Reserves (for contingencies)
- Voltage
- Short circuit current
- Black start

Without these services the electricity system would not be stable.

Beside of these text book types of ancillary services West Denmark also used automatic reserves to maintain the planned exchange on the Danish-German border. For this type of reserve a signal is controlling a power plant based on the difference between planned and actual exchange. Typically (November 2007) +/-140 MW of this type are required to West Denmark.

Most of the ancillary services are rewarded by a combination of a fixed and a variable price. Fixed price (or reservation price) are used to reward that the reserves exist when needed. Some reserves are seldom activated so an energy-only market would not be attractive (or would be associated with high risk) for the producers.

Regulating power in Denmark is usually paid both a reservation price and an activation price. However it is also possible to offer regulating power without receiving the reservation price. Without the reservation price the bid shall be placed 1 hour before the operational hour. With the reservation price the bid must be placed the day before. In other countries regulating power is dominated by energy-only payment. E.g., in Norway in summer time, only energy payment is used. In winter a reservation price is also possible (the RKOM market, regulating power option market).

Markets for ancillary services in Denmark:

	West/East Denmark	Fixed payment (reservation) Typical price	Energy payment
Automatic frequency controlled normal reserves (primary reserves)	West: +/-25 MW East: +/- 25 MW	Yes, monthly tenders West: 1.5 MDKK/ month East: 1 MDKK/ month	No
Automatic frequency controlled disturbance reserves	East: 28 MW	East: 1 MDKK/ month	
Automatic reserves - LFC (controlled by deviation from planned flow on Danish-German border)	West: +/-140 MW	Yes, monthly tenders West: 10 MDKK/ month	Yes (Related to spot price +/- 100-125 DKK/MWh, and to regulating price)
Manual reserves	West: +630/-160 MW East:	Yes (but not a requirement): West: Monthly reservation price of 25 kDKK/MW/month Mainly daily tenders East: 415 MW for a year for 172 MDKK	Yes (activated via Nordic NOIS system)
Black start	West: 40 MW	West: 15 MDKK	
Forced operation	2 central power plants in east and in west	Prices not published	

Power producers who receive a fixed price are obligated to bid into the balancing market (regulating power). The balancing market is managed by Statnett (see Danish prices and volumes in Figure). This procedure secures that the regulation within the hour are handled in a competitive way, as the producers receiving a fixed price are not guaranteed to be activated, but has to compete with all the other bidders.

Mill. DKK	2006
Manuel reserves	493
Automatic reserves	332
Black start and forced operation	44
Total	869

28. marts 2007 – Aktørseminar, Hans Erik Kristoffersen, Energinet.dk

Figure 3: Volumes and prices in the regulating power market for DK-West. Data from 1st January to 31st December 2007. Prices are presented as duration curves. Values above and below +1,1000 and -1,000 DKK/MWh are omitted.

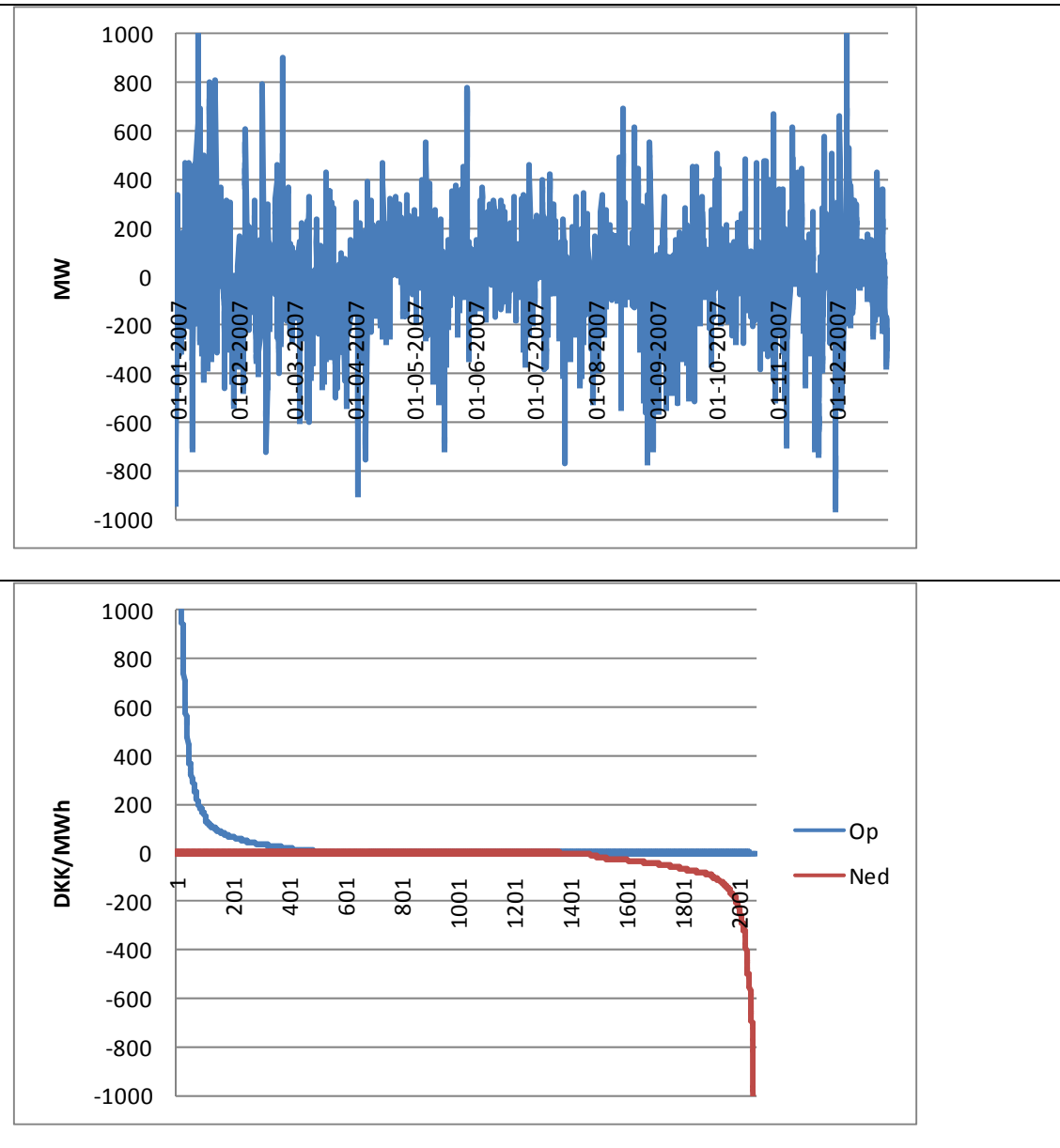

References

- Copenhagen Economics (2006): The economic consequences of capacity limitations on the Oeresund connection.
- COWI (2004): Retningslinjer for samfundsøkonomisk analyse af investeringer i transmissionskapacitet
- Ea Energy Analyses and COWI (2007): Steps for improved congestion management, TemaNord 2007 57

- ERGEG (2007), Cross Border Framework for Electricity Transmission Network Infrastructure – An ERGEG Conclusions Paper.
- ERGEG (2006, a): ERGEG Draft Proposal on Guidelines on Inter TSO Compensation. E06-CBT-09-06. European Regulators Group for Electricity and Gas
- ETSO (2006): An Overview of Current Cross-border Congestion Management Methods in Europe
- Merlin. A. (2005): An overview from the electricity transmission system operator’s perspective. European Review of Energy Markets- Volume 1, issue 1, September 2005
- Nordel (2005, a): Report on Financing and Organisation of In-vestments in Prioritized Cross-sections – A background report prepared by the Nordel Market Committée in the Nordel project on Enhancing efficient functioning of the Nordic electricity market
- Nordel (2005, b): Enhancing Efficient Functioning of the Nordic Electricity Market. Summary and Conclusions
- Nordel (2006, a): Prioritised cross-sections. Reinforcement measures within the Nordic countries. Status, June 2006
- Nordel (2006, b): Principles for determining the transfer capacity in the Nordic power market
- Nordel (2002), Översyn av elspotindelningen och förutsättningarna för mothandel på den nordiska kraftmarknaden.
- Nordic competition authorities (2007): Capacity for Competition – Investing for an Efficient Nordic Electricity Market, No. 1/2007
- Nordic Council of Ministers (2006): Coordination of network operations and system responsibility in the Nordic electricity market. TemaNord 2006:518
- NordREG (2007): Congestion Management in the Nordic Region – A common regulatory opinion on congestion management, Report 2/2007
- RAM-løse edb, Elkraft System and COWI (2005): Modelling Imperfect Competition on the Nordic Electricity Market with Balmorel
- Rydén et al. (2006): Ten Perspectives on Nordic Energy. Final report for the first phase of the Nordic Energy Perspectives project
- STEM (2004): Hantering av begränsningar i det svenska överföringssystemet för el – Ett nordiskt perspektiv
- STEM (2005). Investeringar i elproduktion. 2005: 1. ER 2005:24. Swedish Energy Agency.
- Svenska Kraftnät et al. (2007) - Svenska Kraftnät , Svensk Energi och Svensk Näringsliv: Prismråden på elmarknaden (POMPE), EMIR 2007:02

Appendix 1: Reduced transmission capacities

Code	Reason
10	Normal capacity (100 MW tolerance)
11	Planned outage on cross-border connection
12	Network failure on cross-border connection
13	Thermal limitation on cross-border connection
14	Internal congestion due to planned outage
15	Internal congestion due to network failure
16	Internal congestion due to stability
17	Internal congestion due to regional power balance
18	Increased reliability margin
19	Unavailable system protection
20	Reduced amount of operational reserves

4.0 Overview of Current Nordic Electricity Market

21	Constrained regional power balance
22	Step by step restriction
23	Ramping in Elspot
90	Not available
99	Other reasons

4.0 Overview of Current Nordic Electricity Market

Code	1	4	10	11	12	13	14	15	16	17	18	20	21	22	23	90	99	Total
NO1_NO2	0	0	574	0	0	0	638	0	0	0	0	0	0	0	0	0	0	6383
NO1_SEA	0	0	222	13	0	0	376	0	24	0	0	0	0	20	0	0	0	6383
NO2_NO1	0	0	574	0	0	0	638	0	0	0	0	0	0	0	0	0	0	6383
NO2_NO3	0	0	570	19	0	10	395	0	0	0	16	0	0	0	0	0	0	6383
NO2_SE	0	0	501	18	0	21	111	0	14	0	0	0	0	0	0	0	0	6383
NO3_NO2	0	0	570	19	0	10	555	0	0	0	0	0	0	0	0	0	0	6383
NO3_SE	0	0	463	77	0	32	128	0	65	0	0	0	0	0	0	0	0	6383
SE_NO2	0	0	486	6	0	21	128	0	14	0	0	0	0	0	0	0	0	6383
SE_NO3	0	0	495	54	0	0	136	0	11	0	0	0	0	0	0	0	0	6383
SEA_NO1	0	0	350	52	0	30	126	0	12	10	0	0	12	35	0	0	0	6383
FI_SE	0	0	406	31	71	0	132	24	66	32	0	0	0	0	0	168	0	6359
SE_FI	0	0	417	34	71	0	977	24	52	0	0	71	0	0	0	168	7	6359
DK2_KT	0	0	613	18	6	0	9	0	0	0	0	0	0	0	0	0	0	6335
DK2_SEA	0	0	386	99	96	0	505	0	74	40	0	0	0	85	0	0	0	6335
KT_DK2	0	0	613	18	6	0	8	0	0	0	0	0	0	0	0	0	0	6335
SEA_DK2	0	0	353	84	96	8	651	0	10	16	0	0	27	78	0	0	0	6335
DK1_DK1A	0	48	252	10	16	0	573	0	16	47	0	0	0	0	0	0	14	6143
DK1A_DK1	0	48	284	10	15	0	549	5	58	0	0	0	0	0	0	0	10	6143
DK1A_NO1	0	24	349	46	18	0	252	0	0	0	0	0	0	0	78	0	0	6143
NO1_DK1A	0	24	347	47	18	0	190	0	0	0	0	0	0	0	14	0	0	6143
SEA_DK1A	1	72	465	60	24	0	313	0	20	0	0	0	8	0	14	0	0	6022
DK1A_SEA	0	50	417	60	24	0	578	0	44	0	0	0	0	0	72	0	0	5951
SE_SEA	0	0	120	0	0	0	0	0	0	0	0	0	0	0	0	503	0	5159
SEA_SE	0	0	96	0	0	0	0	0	0	0	0	0	0	0	0	503	0	5135
DK1_KT	0	0	0	0	0	0	0	0	0	0	0	0	0	0	0	508	0	5087
KT_DK1	0	0	0	0	0	0	0	0	0	0	0	0	0	0	0	508	0	5087
DK1_NO2	0	0	24	0	0	0	0	0	0	0	0	0	0	0	0	0	0	24
DK1A_NO3	0	0	24	0	0	0	0	0	0	0	0	0	0	0	0	0	0	24
DK2_FI	0	0	24	0	0	0	0	0	0	0	0	0	0	0	0	0	0	24
DK2_NO2	0	0	24	0	0	0	0	0	0	0	0	0	0	0	0	0	0	24
FI_DK2	0	0	24	0	0	0	0	0	0	0	0	0	0	0	0	0	0	24
FI_KT	0	0	11	0	0	0	13	0	0	0	0	0	0	0	0	0	0	24
FI_NO2	0	0	24	0	0	0	0	0	0	0	0	0	0	0	0	0	0	24
KT_FI	0	0	24	0	0	0	0	0	0	0	0	0	0	0	0	0	0	24
NO2_DK1	0	0	24	0	0	0	0	0	0	0	0	0	0	0	0	0	0	24
NO2_DK2	0	0	24	0	0	0	0	0	0	0	0	0	0	0	0	0	0	24
NO2_FI	0	0	24	0	0	0	0	0	0	0	0	0	0	0	0	0	0	24
NO3_DK1A	0	0	16	0	0	0	0	0	8	0	0	0	0	0	0	0	0	24
Total	1	26	976	74	71	12	182	53	48	43	16	71	47	21	43	205	25	1591
	0,0	0,2	61,	4,7	4,5	0,8	11,	0,0	3,0	0,3	0,1	0,0	0,0	0,1	0,3	12,	0,2	100,
First 22 lines	1	26	971	74	71	12	182	53	48	43	16	71	47	21	43	336	25	1384
	0,0	0,2	70,	5,4	5,2	0,9	13,	0,0	3,5	0,3	0,1	0,1	0,0	0,2	0,3	0,2	0,2	100,

Data from 12. March 2007 to 2. December 2007 (6383 hours).

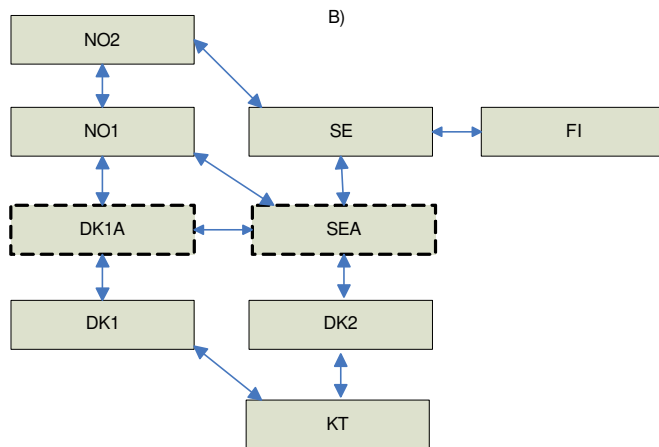

Nord Pool price areas. Here shown with only two Norwegian areas (can be up to four depending on conditions). DK1A and SEA are two optimization areas.

Contacts

Mikael Togeby, mt@eaea.dk.
 Stine Grenaa Jensen

4.1 Real-time energy market

Technical description

Main issues

Title	Real-time energy market
Type of market	Physical market
Generation or demand	Both
Transmission or distribution	Both
Scale	Any
Supporting systems and procedures	Interval meters and online communication needed
Main players	Power retailers, power producers

Brief description

For an efficient resource allocation to take place, every producer and consumer of electricity should trade at the same competitive market price (which may possibly be offset in different locations due to congestion). Due to the continuously changing conditions of the power system and available generation capacity in particular, the competitive market price may vary a lot during time, even from minute to minute. To secure a constantly efficient allocation, the market price must therefore be recalculated and updated as close to real-time as possible, to provide the right incentives for every player in the market to adjust the production or consumption so that the marginal cost or value equals the market price [1].

The present Nordic market architecture does, however, not include a true real-time market. Actual deviations from the volumes traded on the forward market (day-ahead) are settled with a price that is based on the outcome of the regulation market. The settlement is done somewhat differently in each of the Nordic countries, with at least one major difference being the use of a one-price or a two-price system. In the one-price system, a single price is calculated based on the least favourable offer accepted by the TSO on the regulation market. Any deviation from the forward-traded volume is settled using that same price, regardless of the sign of the deviation. With the two-price system currently in use in Denmark, a marginal price of regulation power is calculated similarly, but the price is only used to settle deviations that added to the total system unbalance. Deviations that reduced the total system unbalance are settled with the (for the generator less attractive) day-ahead price for the hour [2].

This practice for settling real-time deviations from the forward-traded volumes has two major deficiencies: First, and most important, the real-time price is calculated after the hour of operation meaning that it is not possible for the market players to react on it; second, even if the price was available in real-time, the two-price system prevents the market players from reacting efficiently, since they are not always subject to the actual competitive market price. The introduction of a real-time market that provides truly competitive, efficient prices on a short time horizon addresses both issues. The real-time market is a not a replacement of the existing forward and contract markets, it is an addition to these markets that secures the provision of real-time prices to the market players. To maintain a high security of supply and to hedge the risk of unreasonable electricity prices, the majority of the energy should still be traded in forward market(s) [3].

Impact

Benefits (and drawbacks/limitations) to power system

The benefits of a real-time energy market in terms of efficient resource allocation have already been outlined in the introduction. A derived effect of the real-time market is that the regulation market is no longer necessary, at least not in its current form. That is particularly interesting for wind turbines and other intermittent power producers. As the amount of intermittent generation increases, the need for regulation power is also increased. But with the current practice only few generators participate in the regulation market, and only some that are able to predict and guarantee their production for the next hour and a half (the regulation market is closed 30 minutes before the hour of operation). With a real-time market, any producer who is able to adjust its production can do so and get paid the prevailing power price, which is continuously determined by the power supply and demand. This benefit of the real-time market is particularly strong if demand can also respond to the real-time price. A number of challenges must be addressed when designing the real-time market. The computational burden will be somewhat larger than with the currently used system, and the need for online communication with every market player is to be considered.

Dependence on other measures

A real-time market may be independently implemented in the Nordic system.

Business issues

Costs

The two-price system currently in use generates an income for the TSO that is used to lower the grid tariffs. This income from the settlement process must be generated in another way or the grid tariffs increased.

Status

Existing installations (examples if available)

In Norway, the one-price balance settlement is used with success. It is still not a real-time market, but the unbalances are settled with the same price for positive and negative unbalances. The market players advocate the one-price system and point out the simplicity of the system as an incentive for smaller market players to enter the market [2]. On the Olympic Peninsula, Washington, USA, a research experiment has been conducted with a local real-time market comprising loads as well as small generators. For the particular case, congestion management was the primary motivator. The results are very promising and show a significant influence of the real-time price on consumers as well as producers of power [4]. The market in the project is a 5-minute contract market, with consumers as well as producers placing bids for the following 5-minute period. The price is calculated as a uniform marginal price, which is then published. An interesting feature of the market is that there is no day-ahead market in the system, as all resources have a very short response time. An example of a large-scale real-time market is operated in the USA by PJM. The market is, like the Nordic market, a two-settlement system with the first settlement based on the outcome of a day-ahead market, but unlike the Nordic market, the second settlement is based on the outcome of a real-time market, that calculates locational marginal prices (LMP) for every 5-minute period. The bids from the day-ahead market are carried over to the real-time market, unless altered by the bidders after the day-ahead market has been cleared [5]. The examples of existing installations are summarized below:

Place	Capacity	Function
Norway	GW	Single price settlement
Olympic Peninsula	MW	Real-time local market
PJM	GW	Real-time large-scale market using LMP for congestion management

Potential development

Real-time energy markets have the potential to be open to every power producer and consumer, on any scale. The limiting factors are communication lines and computational power.

Research and development

In the section *Existing Installations*, an experimental research project on the Olympic Peninsula is described. The project uses 5-minute contracts to control local generation and demand. The research is part of the GridWise programme and is now concluded. The results are published in [4] A somewhat similar local market has been modelled and simulated in [6], however this project takes the real-time approach even further and completely eliminates the contracts. A central controller posts a price and the market players respond to the price by adjusting their production to the marginal cost (loads were not included in the model). The price is changed frequently to balance generation and demand and maintain the scheduled net exchange between the local area and the surrounding power system.

References

- [1] S.Stoft, *Power System Economics*, IEEE Press, 2002
- [2] Nordic Energy Regulators, *Development of a Common Nordic Balance Settlement*, NordReg, 2006
- [3] Peter Cramton, Steven Stoft, *Why We Need to Stick with Uniform-Price Auctions in Electricity Markets*, The Electricity Journal, 2007
- [4] D. Hammerstrom et al., *Pacific Northwest GridWise™ Testbed Demonstration Projects, Part I. Olympic Peninsula Project*, National Technical Information Service, U.S. Department of Commerce, October 2007
- [5] Andrew L. Ott, *Experience with PJM Market Operation, System Design, and Implementation*, IEEE Transaction on Power Systems, Vol. 18, No. 2, May 2003
- [6] Rasmus Skovmark, Johan Holkmann Jacobsen, *Analysis, Design and Development of a Generic Framework for Power Trading*, M.Sc. thesis, available from The Technical University of Denmark, 2007

Contacts

Preben Nyeng, pony@elektro.dtu.dk.

4.2 Nodal pricing – congestion management in transmission systems

Technical description

Main issues

Title	Nodal pricing – congestion management in transmission systems
Type of market	Physical market, day ahead
Generation or demand	Demand, generation and transmission
Transmission or distribution	Transmission
Scale	> 100 MW
Supporting systems and procedures	
Main players	Power exchange, based on commercial bids from market players, and information about transmission grid from TSO

Brief description

Nodal pricing is a recognised method for optimal congestion management in meshed transmission systems.

Nodal pricing can be defined as the marginal cost of delivering one additional MWh to a location while respecting all limits (including contingency limits, stability limits etc.) and losses.

A node is a physical location, e.g. a transformer. In general each node will have a different price.

Market players should – as now – give bids to the power exchange; however bids should be given per node.

With nodal pricing the ideal of marginal pricing is realised. The optimal dispatch have different characteristics than we are used to: Power may flow from expensive to less expensive nodes. When one or more restrictions exist this may be optimal.

Critics against using nodal pricing include questions concerning hedging: Will the large number of prices make this more complicated? Or less predictable? Also, the large number of prices can appear complicated for laymen.

Nodal pricing is illustrated in appendix 1.

Impact

Benefits to power system

Nodal pricing will secure the optimal utilisation of all components in the system: transmission lines, generation and demand response.

When using market splitting (as in the Nordic area) less optimal price signal will exist:

- The price signal will be averaged out within each price area. All generators are assumed to have the same marginal impact of a congested line (independent of its actual location in the grid)
- The TSO will have the task of reducing transmission capacity allocated to the market. This can include reduction due to internal congestion or due to stability concerns. Today, such reductions are announced before the spot market is settled – but based

on the TSO's guess on the next day's prices. With nodal pricing such consideration is a part of the computation of the individual prices.

It is important to note that nodal pricing is not the same as market splitting with many price areas. The crucial difference is that the physical laws of power flows in AC systems are included in nodal pricing. With just one restriction (e.g. one congested line or one stability concern) or with losses included in the calculation - each node will typically have different prices.

The most important difference between market splitting and nodal pricing is the nodal pricing includes information about the power flow in meshed AC transmission lines. The flow is described by Kirchhoff's laws. Since DC lines can be completely controlled by the operator, the value of nodal pricing is less obvious across DC lines. However, a nodal pricing system can operate across both AC and DC lines.

An initial implementation of nodal pricing in the Balmorel model, with simplified assumptions about transmission line characteristics, has indicated that nodal pricing gives significant different dispatch and less total costs.

In [1] a simple implementation of nodal pricing has been tested for the Nordel system.

In [5] nodal pricing is analysed for the German electricity sector in relation to a large amount of off shore wind power. A model is developed with 310 nodes and 425 lines describing the 380 kV and the 220 kV grid in Germany. A price elastic demand is assumed. No border flows are represented in the study. The study concludes that welfare benefits of between 0.6 and 1.3% when nodal pricing is compared with uniform pricing. If adding 8,000 MW off shore wind to the system, the welfare benefits increase to more than 2%. In all cases losses are lower with nodal pricing compared to uniform prices.

In [10] a model of England and Wales indicates a 1.3% welfare gain when moving from uniform prices to nodal pricing. The gain increases in the case of market power.

Limitations

In [9] nodal pricing has been presented to Nordic stakeholders. The method is generally considered to be the ideal and long term solution. However, many considered it as complicated and difficult to understand. More information about the practical experiences with nodal prices in USA and New Zealand was in demand.

[10] indicate that nodal pricing creates politically sensitive gains and losses.

Dependence on other measures

Nodal pricing only in Denmark would not reveal the full benefit. Large areas as Nordel or UCTE could use nodal pricing.

Financial contracts need to be redesigned to cope with the higher number of prices.

Environmental impact

Business issues

Costs

Patents

Status

Existing installations

Nodal pricing is widely used in transmission systems, e.g. in the PJM market in USA, in New Zealand and in Singapore.

In [5] from 2005 the following text describes experiences with nodal pricing: “Nodal pricing was first implemented in New Zealand (1997), followed by some US markets (e.g. PJM 1998, New York 1998, New England 2003).⁷ On 1 April 2005, the British Electricity Trading and Transmission Arrangements (“BETTA”) were introduced in UK extending the earlier “New Electricity Trading Arrangements” for England and Wales (NETA) to Scotland. With BETTA, nodal pricing was introduced for the Great Britain grid on the basis of marginal transmission investment requirements (Tornquist, 2005). The California ISO is actually redesigning the procedures by which it performs forward scheduling and congestion management; CAISO plans to introduce nodal pricing by 2007 CAISO (2005).”

Electricity trade in New Zealand take place by placing bids at 244nodes.

Potential development

Research and development

Bottlenecks

Other issues

Next steps

Several activities can be recommended:

- Review (in more details than done here) the experiences with nodal pricing in USA and New Zealand.
- Illustrate the benefit of nodal pricing in the Nordic system. For the purpose of illustration a simplified model could be developed. This could be with e.g. 20 nodes. It is not necessary to have the full number of nodes for this purpose.
- Denmark is not included in [5], however much of the additional wind power is located off shore close to Denmark. A possibility could be to expand the model to include Western Denmark. The model is formulated in the general model language GAMS (as e.g. Markal and Balmorel).

References

- [1] Ingemann Laustsen, Lau (2005): Spot Pricing of Electricity. Thesis, Department of Economics. Copenhagen University.
- [2] Oren, S.S. (2007): Congestion Management and Transmission Rights: Lessons from Failed Experiments. International Workshop on Transmission access, investment and pricing.

- [3] Intelligent Energy Systems (2004): Regional boundaries and nodal pricing. An Analysis of the Potential Impact of Nodal Pricing and Market Efficiency.
- [4] Energy Market Authority (2006): Introduction to the Singapore new electricity market.
- [5] Leuthold, Florian, Ina Rumiantseva, Hannes Weigt, Till Jeske and Christian von Hirschhausen (2005): Nodal Pricing in the German Electricity Sector – A welfare economics analysis, with Particular reference to implementing offshore wind capacities. Trends in German and European Electricity Working Papers. WP-GE-08b
- [6] Jean-Thomas Bernard (2000): Nodal pricing and transmission losses. An application to a hydroelectric power system. GREEN, Département d'économie, Université Laval, Sainte-Foy, Québec, Canada
- [7] Schweppe, F., M. Caramanis, R. Tabors and R. Bohn (1988): Spot Pricing of Electricity, Kluwer Academic Publishers.
- [8] Stoft, Steven (2002): Power System Economics: Designing Markets for Electricity
- [9] Togeby, Mikael, Hans Henrik Lindboe, and Thomas Engberg Pedersen (2006): Steps for improved congestion management and cost allocation for transit. TemaNord 2007:537. Nordic Council of Ministers.
- [10] Green, R. (2007): Nodal pricing of electricity: How much does it cost to get it wrong? Journal of Regulatory Economics, Vol.31 Issue. 2, pp 125-149.

Appendix 1: Illustrating nodal pricing

To illustrate the function of nodal pricing a simple network example has been constructed and the equations has been solved in GAMS – a software tool that can find optimal solutions. The network is a network with 25 nodes (5 x 5) and in each node a constant consumption of 1 MW take place. The nodes are numbered from 1 to 25 from the upper left to the lower right. It is assumed that the cost of generation electricity in each node is equal to the node number (an arbitrary assumption suited to illustrate the mechanism). See figure 1.1. A node can produce between 0 and 2 MW.

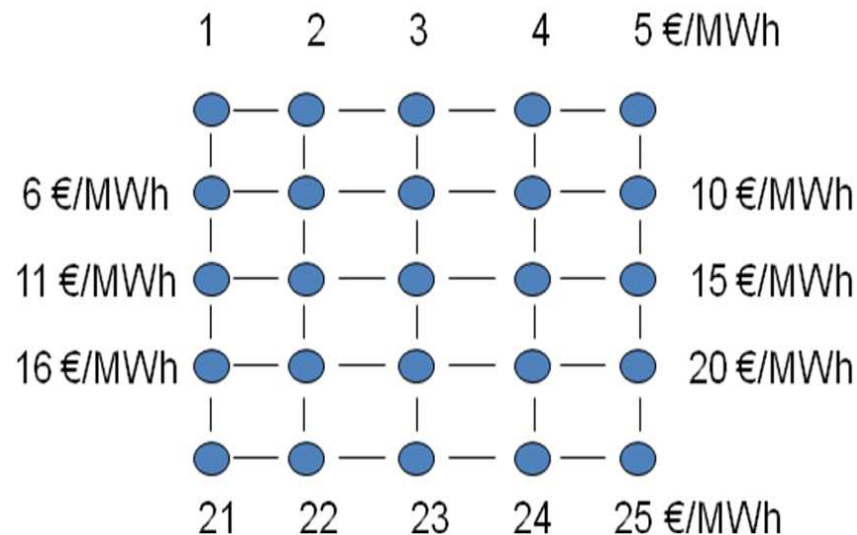

Figure 1.1. The network with indication of node numbers and marginal cost of electricity generation.

The physical characteristics of all lines are the same. This influences the flow in the grid, according to Kirchhoff's second law. To simplify the presentation losses are excluded from the calculations of costs.

No congestion

In no congestions or other restrictions exists the calculation of prices is straight forward (can be calculated without a computer). Since the total demand is 25 MW this can be supplied by the 12 cheapest nodes (no 1-12) with maximum power (2 MW) and the rest (1 MW) from node no. 13. The marginal price is then 13 €/MWh in all nodes. The power flow is from the upper left to the lower right. E.g. from node 1-2: 0.16 MW, 2-3: 0.27 MW, 1-6: 0.84 MW, 6-11: 1.64 MW, 8-13: 2.00 MW, 13-18: 2.00 MW (in all cases right of down). This result is valid both for market splitting and nodal prices. The total cost can be calculated to be 169 € ($2 \times 1 + 2 \times 2 + \dots + 2 \times 12 + 1 \times 13$).

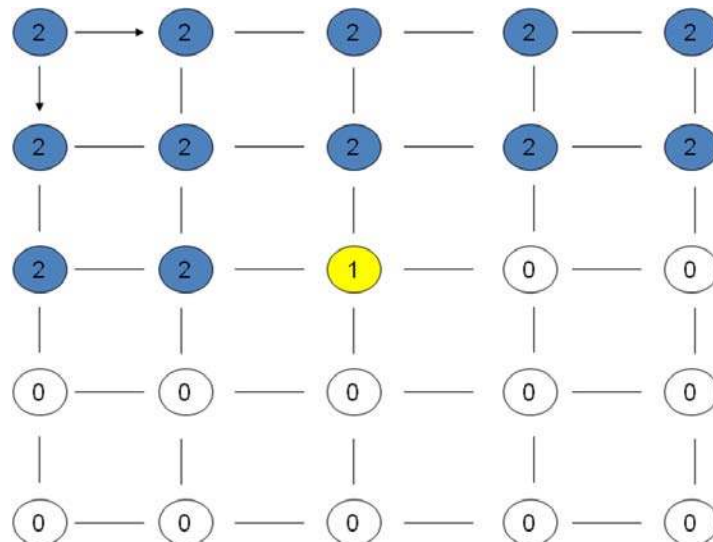

Figure 1.2. Generation in each node, when no constraints exist. The 25 MW is produced by the 13 cheapest generators.

One congestion – nodal pricing

By adding just one restriction the solution become very different. It is assumed that the line between node 13 and 18 only can transport 1 MW. With the above solution 2 MW flowed on this line, so re-dispatch is necessarily to maintain secure operation.

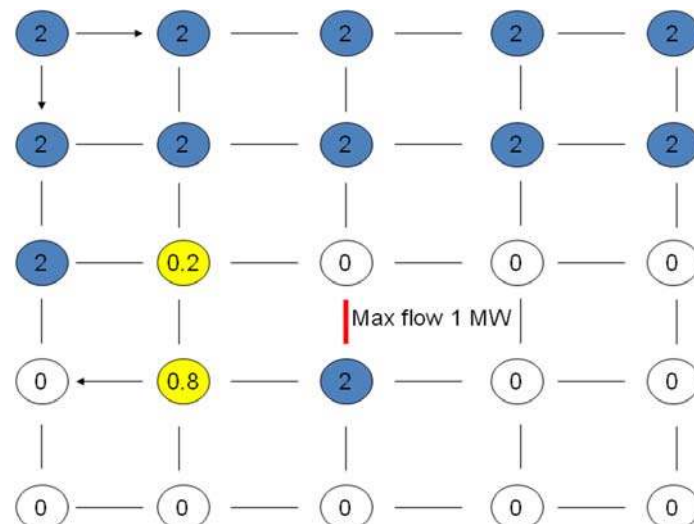
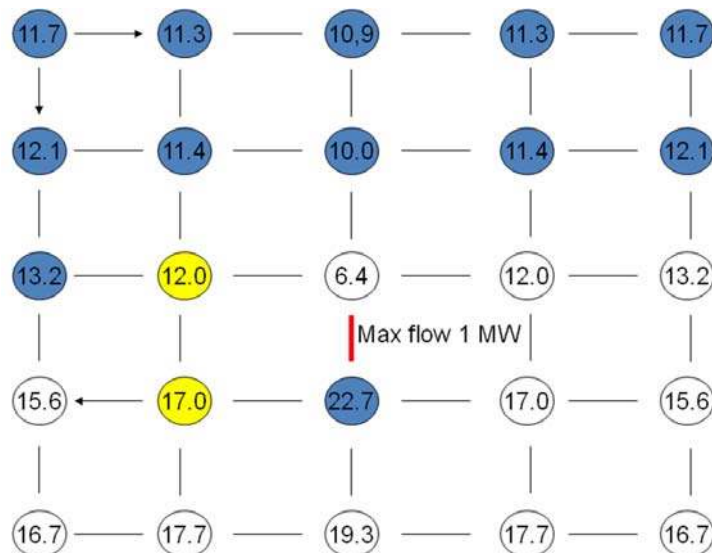

Figure 1.3. Generation in each node, when a single constraint exists. The 25 MW is produced by the 12 cheapest generators in combination with generation in node 17 and 18. This is the cheapest generation if the flow between node 13 and 18 must be 1 MW or less. If generation is moved from node 17 and 18 to generators with lower cost the flow between node 13 and 18 exceeds the maximum.

The total cost with the congestion and with nodal pricing is 184 € - 9% more than without congestion.



Figur 1.4. The prices in the case with one congested line and nodal pricing. The power flow is always to the right or down – except between node 16 and 17, where the flow is to left (from 17 to 16). The prices represent the marginal cost of supplying an extra unit to the node. The lowest price is in node 13. If the demand is increased in this node more can be produced in node 12 and less need to be produced in the expensive nodes 17 and 18.

One congestion – market splitting

With market splitting the same price exist for ach price area. The price areas can be defined in many ways. In this example it would be practical that node 13 and 18 belonged to two different price areas. This can be fulfilled in many ways. We have here assumed two price areas: One area with node 1 to 15, and a second price area with node 16-25. This could represent the cheap and the expensive units.

With these assumption the TSO need to reduce the maximum flow between the two price areas to 5 MW or less. If a higher value is accepted the requirement of maximum 1 MW on the line 13-18 is not fulfilled.

This will lead to the solution illustrated in figure 1.4. The price will be 10 €/MWh in the upper area and 18 €/MWh in the lower area. The total cost will be 194 € - 18% more than with nodal pricing.

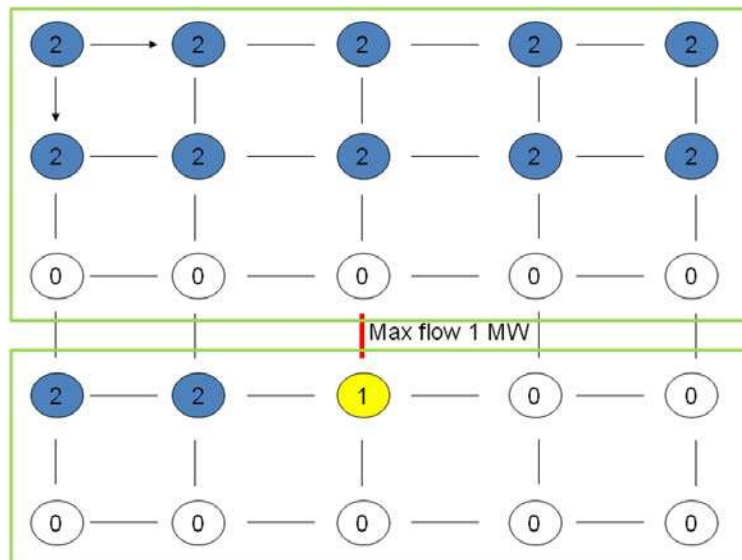

Figure 1.5. Generation in each node with marked splitting in two areas and indicated by the two boxes.

Conclusion

It is illustrated that nodal pricing lead to many different prices if one or more restriction exist – even when the losses are excluded. By including information about the physics of power flow the optimal dispatch can be realised.

The nodal price solution (see figure 1.3. and 1.4.) can not be realised with marked splitting. Even if 25 price areas were used the solution would not be the optimal.

Contact

Mikael Togeby, mt@eaea.dk

Klaus Skytte

4.4.1 Trading arrangements with the continent

Technical description

Brief description

Cross border trade and exchange of power can help smoothing out fluctuations in inland supply and demand. Denmark has both AC and DC connections to the European continent.

The Eastern part of Denmark is part of the NordEl AC-net and has one 400 kV DC transmission line (Kontek) to Germany with a capacity of 600 MW.

The western part of Denmark is part of the UTCE AC-net and has four AC connections to Germany (one 400 kV from Kassø, two 220 kV from Kassø and Ensted power plant respectively, and one 150 kV from Ensted power plant). The total transmission capacity is determined by load conditions in the surrounding networks and is normally around 1500 MW from Denmark to Germany and around 950 MW from Germany to Denmark.

Title	Trading arrangements with the continent
Type of market	Physical market
	Day-ahead market/ Hour-ahead market / Capacity auctions /
Generation or demand	Import/export
Transmission or distribution	Transmission
Scale	150 kV, 220 kV, 400kV network level
Supporting systems and procedures	
Main players	TSO and market actors

Impact

Benefits (and drawbacks/limitations) to power system

Smoothing out fluctuations in inland supply and demand at the transmission network level.

Dependence on other measures

Well functioning markets and co-operation between the system operators. This includes clear market signals of prices and electricity trade.

Environmental impact

There are no direct environmental issues. However, smoothing out fluctuations may decrease the use of emitting peak load capacity and thereby decrease the environmental impact of the power system. Do to the potential large amount of energy that can be smoothed up by trade, the corresponding environmental impact is huge.

Business issues

Costs

Manufacturers

Agreements between the TSO's in different countries. European Market Coupling Company (EMCC)

Patents

Status

Existing installations (examples if available)

Western Denmark

At present, transmission capacity between Western Denmark and Germany is administrated by Energinet.dk and E.ON Netz. The available capacity is offered by *explicit auctions*¹ on yearly, monthly and daily basis. Registered market actors can bid on the auctions.

Yearly auction

Part of the total capacity is offered for one year at the time. The auction is held mid-November each year.

Monthly auction

Additional capacity is offered for on a monthly basis. The auction is held the second Tuesday the month before the reservation takes place.

Daily auction

The remaining available capacity is offered at a day-ahead auction on an hourly basis. The offered capacity includes the non-used reservations from the yearly and monthly auctions since these are "use-it-or-lose-it" reservations.

These explicit auctions will be replaced by *implicit capacity auctions*² by June 2007. The implicit auction will be a daily auction. A new common German/Nordic capacity auction office, European Market Coupling Company (EMCC), has been created which will be responsible for calculating the cross border flows based on the market data received from the power exchanges and the available capacity given by the TSOs in Northern Germany and the Nord Pool area. This will create a better market coupling between the Danish and Northern German power markets.

¹ Explicit auction is when the transmission capacity on an interconnector is auctioned to the market separately and independent from the marketplaces where electricity is auctioned.

² Implicit auction is when the flow on an interconnector is found based on market data from the marketplace/s in the connected markets.

EMCC will cover all connections between the German bidding area of EEX and Nord Pool's bidding areas East Denmark and West Denmark.

E.ON Netz, Energinet.dk, VE Transmission, Nord Pool Spot and EEX agreed to start the operation of day-ahead market coupling between Denmark and Germany on 3 June 2008 for delivery next day.

Eastern Denmark

The use of the transmission capacity in the Kontek cable between Eastern Denmark and Germany is administrated by Nord Pool via *implicit auction* with market splitting between bidding area East Denmark and Nord Pool Spot's German bidding area KONTEK.

At present, Elbas is open for trading in Nord Pool Spot's German bidding area KONTEK controlled by Vattenfall Europe Transmission GmbH. Elbas is open 24 hours a day every day of the week including Saturdays and Sundays.

When the common implicit auction and EMCC are implemented, Nord Pool Spot's German bidding area KONTEK will be closed.

Potential development

The interconnection between Norway and The Netherlands (NorNed). Like the German-Danish interconnection, NorNed will probably (in the long run) be an open interconnection which will be utilised via market coupling of the Dutch and Nordic markets. This will be handled by the power exchanges APX and Nord Pool. However, so far it has not been possible to reach an agreement and the NorNed cable will start up with explicit auctioning.

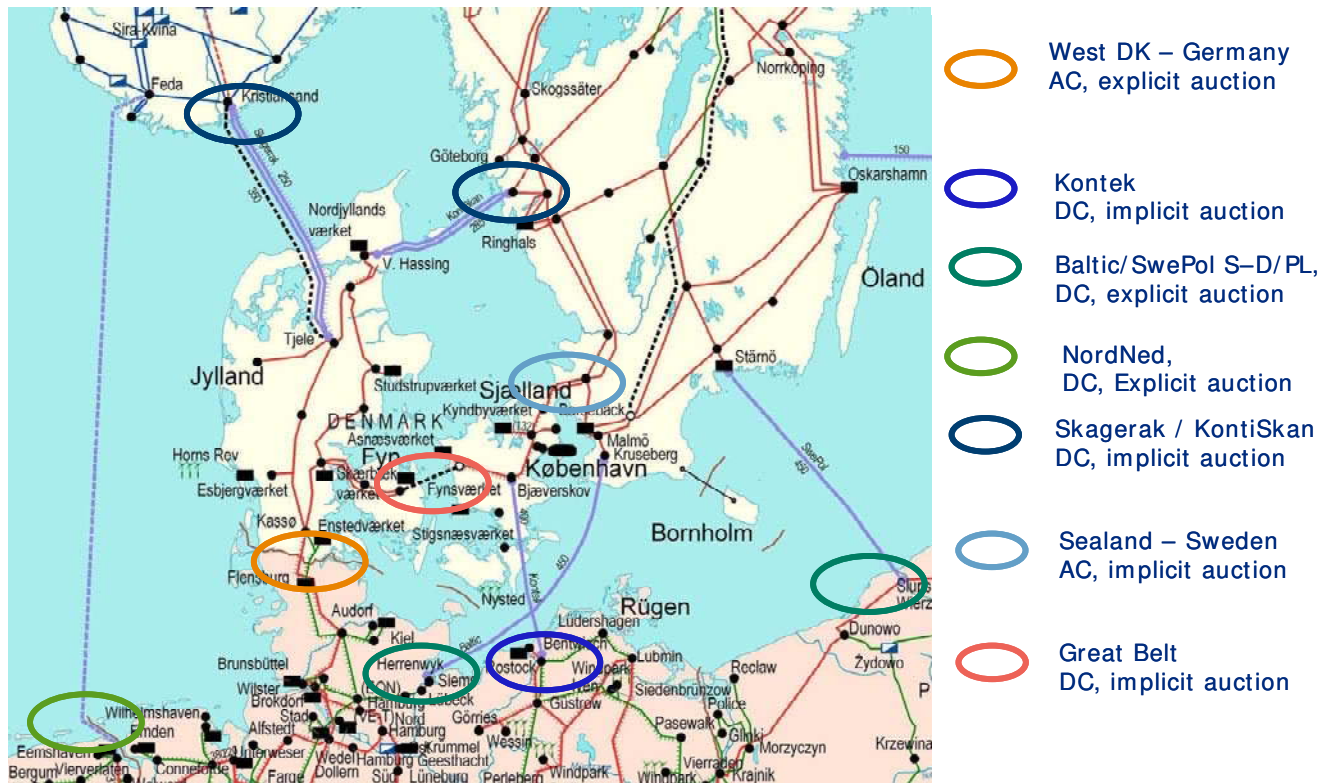

Figur 1: Market coupling between NordEl and the continent.

With the coming market coupling between the Danish and German markets with intra-day trade it is likely that the interconnections between Sweden and Germany (Baltic) also will shift to implicit auction within a few years.

It is still unclear what will happen to the transmission line between Sweden and Poland.

Simultaneously with the changes in Northern Europe ETSO, and especially the TSO's in Germany, Belgium, Netherlands and France, are trying to agree on more market coupling between the European countries. If succeed, this may lead to a market coupled EU electricity market with full market integration ("Nord Pool in all Europe"). In principle this would allow the markets from Gibraltar to Nordcap to be coupled, and thereby create a large buffer that can smooth out fluctuations in the power system.

Research and development

Cross border trade and exchange of power are very important measures for smoothing out fluctuations in inland supply and demand. A couple of systems analyses have been made for wind integration in Northern Europe (e.g. Project Wilmar). However, no studies have looked at the system implication of different auctioning designs for cross border trade and exchange of power – especially with respect to counteract fluctuations.

Likewise, there is a need for analyses of the market designs and the different designs of auctions and what the different designs implies for the flexibility of the systems.

Bottlenecks

Germany is planning to deploy up to 20,000 MW off shore wind power near the Danish border. This large amount of wind power south of the Danish border may imply that the needs for balancing power in Northern Germany and in Denmark are correlated, i.e. the available capacity that can help smoothing out fluctuations in inland supply and demand will be limited.

Other issues

References

- [1] Energinet.dk, Systemplan 2007.
- [2] E.ON, <http://www.eonnetz-eltra-auctions.org/>
- [3] NordPool, <http://www.nordpoolspot.com/> samt <http://nordpoolspot.com/PowerMarket/The-Nordic-model-for-a-liberalised-power-market/Implicit-auction/>
- [4] Project Wilmar, <http://www.wilmar.risoe.dk/>

Contact(s)

Klaus Skytte.

Stine Grenaa Jensen

4.4.2 Market Coupling and Implicit Auctioning between Germany and Denmark

Technical description

Main issues

Title	Market Coupling and Implicit Auctioning between Germany and Denmark
Type of market	Physical market, Day-ahead
Generation or demand	Import/Export
Transmission or distribution	Transmission
Scale	400 kV, 220 kV, 150 kV
Supporting systems and procedures	
Main players	TSOs, power exchanges, and market actors

Brief description

Market coupling means that previously separated activities to get cross-border capacities from transmission system operators via explicit auctions and energy volumes from power exchanges at different times are unified to one single step, i.e., implicit auctions. This means that Traders only have to approach power exchanges to execute energy businesses between Denmark and Germany. Therefore, market coupling will further improve market efficiency and will promote the further integration of regional markets towards a European-wide electricity market.

This year, German and Nordic transmission system operators and power exchanges have agreed to introduce market coupling between Germany and Denmark on June 3rd 2008. The aim is to have an implicit auction for the daily cross-border capacity allocation for both interconnections between Germany and Denmark, and furthermore, any results of the cooperation shall be open to other TSOs and power exchanges according to predefined rules.

The idea behind this implicit auction with market coupling is that the partners can each decide what type of market coupling they want to use. Two methods are possible: Volume coupling and price coupling, which can co-exist.

Volume based coupling (loose coupling)

In volume coupling only the power flow found from the coupling algorithm is used as input in the local price calculations by the power exchanges while they calculate the clearing prices and the volumes per participant themselves. The flow is entered on the local power exchanges as price independent purchase or sales orders – depending on direction of flow.

Price based coupling (close coupling)

With *price coupling*, EMCC's calculates clearing prices, cross-border flow and traded volumes per participant. These are normally used directly by the power exchanges – but they have the right to recalculate prices and volumes. The main difference between these two, is whether or not the coupling company are handing prices or flows to the power exchanges (Consentec, 2007). Notice, that it is still possible for the coupled countries to have other couplings at the same time, e.g., market splitting as in the Nordic area.

In the new agreement the central actors are going to be the European Market Coupling Company (EMCC), which has the following tasks (Nordpoolspot.com):

- collect the available capacity form the TSOs

- collect anonymized order books from the power exchanges
- calculates the optimal use of capacity
- place additional bids at the power exchanges involved as power exchange ‘participant’, hence buys, ships, sells energy across the borders
- collect the arbitrage revenue, i.e., congestion rent
- settle the congestions rent pro rata distribution among the capacity holders

The daily tasks of EMCC are illustrated in Figure 1 and Table 1, where each arrow illustrates actions to be taken by the market participants during the day.

- 8.30	Firm schedules (nomination of annual and monthly capacity for DK-West
- Before 9.30	Calculation of/agreement on available capacity (ATC) for MC
- 10.00	Publication of ATC for MC by EMCC
- 12.00	Gate closure of PXs
- App. 12.10	Order books to the EMCC (anonymized)
- 12.30	EMCC results transmitted to PXs
- Before 13.15	Publication of PXs' results
- Before 14.30	Trader and EMCC schedules (DK: 15.00)

Table 1: Daily operations. All time indications are provisional. (Source: Nordpoolspot.com)

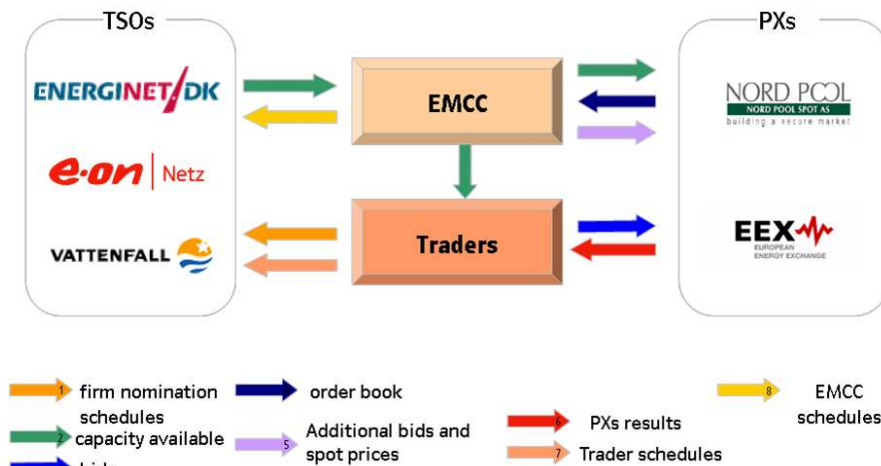

Figure 1: Overview of the daily operations in the new auction design. Actions are taken in the order of the arrows (Source: Nordpoolspot.com)

Impact

Benefits to power system

Implicitly capacity auction secures a coordinated clearing of the power and transmission capacity markets. One could say that implicit auction is one step closer to the nodal pricing method (see task 4.3.2), which is often considered to be the theoretical best way to handle congestion (Kumar et al., 2005).

Compared to explicit auctioning, market coupling will further improve market efficiency and will promote the further integration of regional markets towards a European-wide electricity market. This effect is illustrated in Figure 2 and Figure 3, where the first figure shows flow on transmission lines given price differences using explicit auction, and the second shows it using implicit auction. The conclusion is that the physical flow more often goes in the right direction (from high price or low price areas) when using implicit instead of explicit auction.

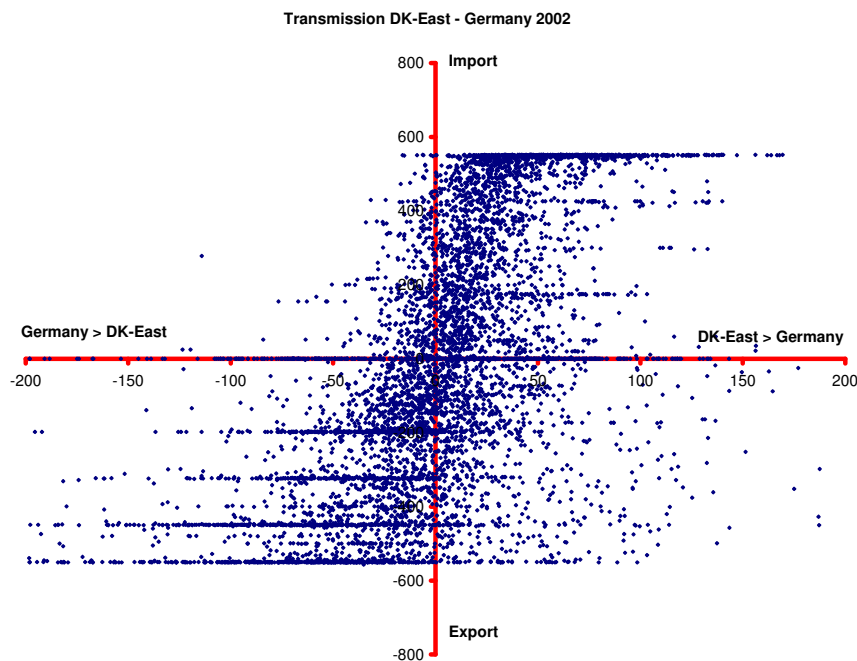

Figure 2: Transmission on Kontek compared to price difference between DK-East and Kontek in 2002, when explicit auction was used. (Data: www.nordpool.com)

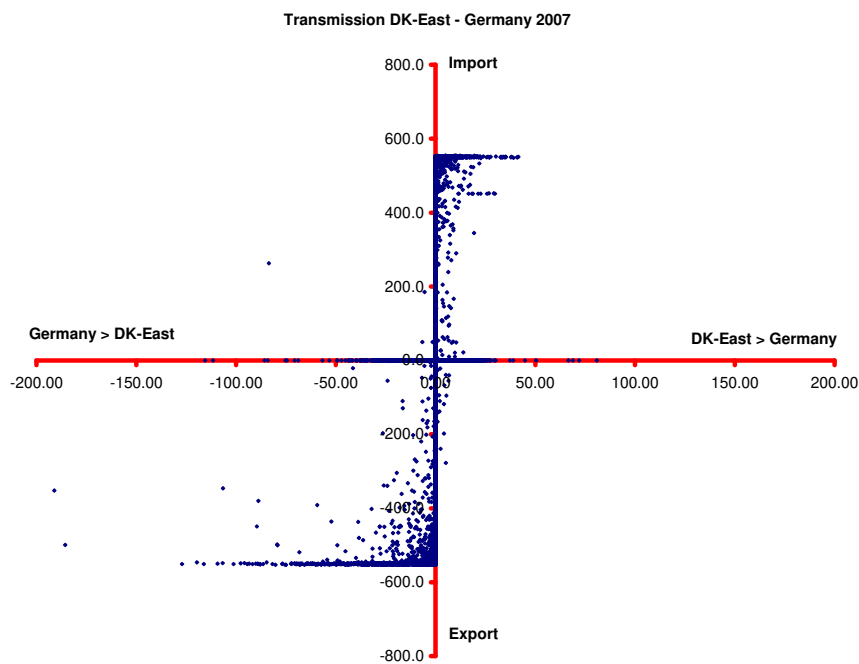

Figure 3: Transmission on Kontek compared to price difference between DK-East and Kontek in 2007, after implicit auction and market splitting was implemented. (Data: www.nordpool.com)

Limitations

The road towards a more integrated system goes through a bumpy landscape. The goal of ‘only’ a market coupling of all European markets like the new initiative between Denmark and Germany needs a lot of adjustment and coordination between market actors, TSOs, power exchanges, etc. But the experience with EMCC will, hopefully, be a success, and hence, the first step towards a further integration of the European markets.

The present arrangement only includes day-ahead trade, whereas, monthly and yearly auctions remains explicit.

Dependence on other measures

Need for the TSO’s and the power exchanges to co-ordinate the auction method. In the mentioned case this is done by co-ownership of EMCC.

Environmental impact

Business issues

Costs

Patents

Status

Existing installations

At present the trade design between Denmark and Germany is being changed from explicitly auction to implicitly auction with market coupling for the Western connection, and from

implicit auction with market splitting¹ to implicitly auction with market coupling for the Eastern connection (illustrated in Figure 4) .

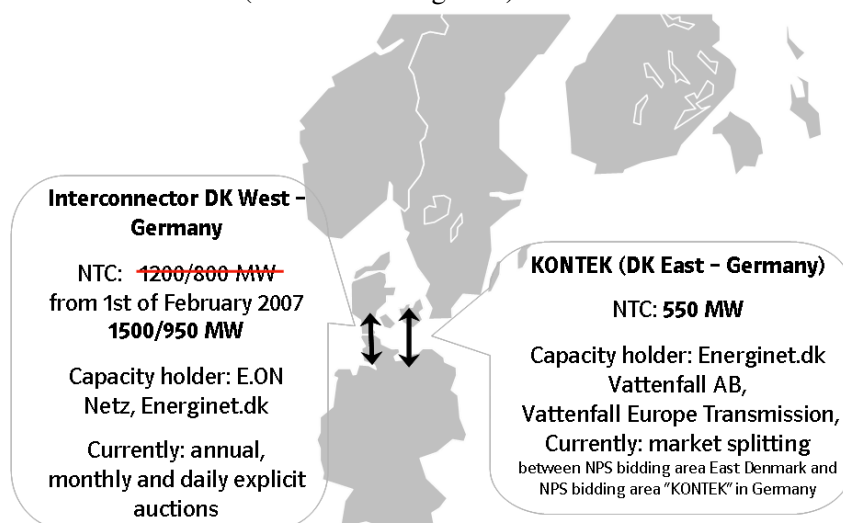

Figure 4: Overview of the current interconnections at the German-Danish border. (Source: Nordpoolspot.com)

Potential development

The implementation of implicit markets does not include monthly and yearly auctions. These are still open for discussion. The most forward suggestion would be to include them in the implicit auction method, but some aspects still gives argument for the explicit auction method for long-term agreements. As an example, Eurelectric finds that it is important to use explicit auctions for long-term allocations as “it ensures that market participants are able to hedge their position for their cross-border operations in the long-term for at price fixed beforehand.” (ERGEG, 2006). This does not only apply for power producers, as the need for more flexible systems probably rises a need for more investments in transmission capacity.

An issue not handled in the above discussions of implicit auctions is intra-day and balancing markets, i.e., how are the coupling between these and the transmissions handled. One could imagine a solution where the coupling company also coordinates reserved transmission capacities for unbalances in order for those to be optimally allocated as well. ERGEG suggests several alternatives for acquisition of transmission capacity for balancing purposes (ERGEG, 2006). One is that the TSOs can acquire the desired amount of capacity through the day-ahead markets, which secures a market based handling of transmission capacity for balancing purposes rather than the present bilateral agreement between the TSOs.

Research and development

For the coming period it will be very important to collect and analyse the experience from the EMCC initiative. This does not only include the coming daily operation data, but also more on how the process of co-ordination has been so far between the partners in EMCC. This part is very useful for other regions that wish to copy the EMCC initiative.

¹ With market splitting (as in the Nord Pool area) the cross-border activities are handled by one single power exchange, and hence, cross-border flows are determined by the use of price areas.

Bottlenecks**Other issues****Next steps**

A natural next step would be to include more partners in the EMCC, e.g., Sweden, Norway, the Netherlands, and Poland, which all have cross-border activities with Denmark and/or Germany. The Netherlands could be of special interest since the Norned cable going from Norway to the Netherlands are expected to have significant influence on the power flows in both Denmark and Germany, and since, the Norned cable is planned to be handled through explicit auctions that could lead to non optimal power flows.

References

- [1] Bunn, D., and G. Zachmann (2006): Market Power in Transmission Auctions.
- [2] Stoft, S. (2002): Power System Economics: Designing Markets for Electricity
- [3] Joskow, P.L., and J. Tirole (2000): Transmission rights and market power on electric power networks. RAND Journal of Economics, Vol.31(3), pp. 450-487.
- [4] Gilbert, R., Neuhoff, K., and D. Newbery (2004): Allocating transmission to mitigate market power in electricity networks. RAND Journal of Economics, Vol.35(4), pp. 691-709.
- [5] Kumar, A., Srivastava, S.C., and S.N. Singh (2005): Congestion management in competitive power market: A bibliographical survey. Electric Power Systems Research, Vol.76, pp. 153-164.
- [6] Salant, D. (2004): Auctions for Transmission Capacity Rights: The Empire Connection Experience. The Electricity Journal, Vol.12(5), pp. 62-68.
- [7] www.nordpoolspot.com
- [8] Euroelectric, Union of the Electricity Industry (2005): Improving Interconnection Capacity Allocation. EUROELECTRIC Position Paper.
- [9] Consentec (2007): Towards a common co-ordinated regional congestion management method in Europe. Final report commissioned by the European Commission, Directorate-General Energy and Transport.
- [10] ERGEG (2006): Guidelines of Good Practice for Electricity Balancing Markets Integration (GGP-EBMI). Report E05-ESO-06-08.

Contact(s)

Klaus Skytte

Stine Grenaa Jensen

4.4.3 Full EU Market Coupling

Technical description

Brief description

A full EU market coupling will give the maximum flexibility of cross border trade in Europe. In principle this would allow the markets from Gibraltar to Nordcap to be coupled, and thereby create a large buffer that can smooth out fluctuations in the power system. Market coupling with cross border trade and exchange of power can help smoothing out fluctuations in inland supply and demand. Market coupling gives a simultaneously allocation of energy and capacity. I.e., market-coupling integrates the energy and transmission capacity markets and ensures that flows of electricity go in the right direction, i.e. from the low to the high price areas.

Title	Full EU Market Coupling
Type of market	Physical market
	Day-ahead market/ Hour-ahead market / Capacity auctions /
Generation or demand	Import/export
Transmission or distribution	Transmission
Scale	150 kV, 220 kV, 400kV network level
Supporting systems and procedures	
Main players	TSO and market actors

Impact

Benefits (and drawbacks/limitations) to power system

Smoothing out fluctuations in inland supply and demand at the transmission network level.

Dependence on other measures

Well functioning markets and co-operation between the system operators. This includes clear market signals of prices and electricity trade.

Environmental impact

There are no direct environmental issues. However, smoothing out fluctuations may decrease the use of emitting peak load capacity and thereby decrease the environmental impact of the power system. Do to the potential large amount of energy that can be smoothed up by trade, the corresponding environmental impact is huge.

Business issues

Costs

Manufacturers

Agreements between the TSO's and power exchanges in different countries. ETSO, EuroPEX, Eurelectric and European Market Coupling Company (EMCC)

Patents

Status

Existing installations (examples if available)

There exist several *regional* incentives towards market coupling. Examples are:

- Denmark – Germany (**EMCC**)
Daily cross-border capacity trade between by implicit auction. The partners involve are Nord Pool Spot, EEX, E.ON Netz and Vattenfall Europe Transmission. The See description in other impact report.
- France – Belgium – Holland, **TriLateral Coupling (TLC)**
Launched on 21 November 2006 Trilateral Market Coupling was the first coupling of separate, independent exchanges in Europe. The six parties involve are RTE, Pownext, Elia, Belpex, TenneT and APX.
- Holland – Norway (**NordNed**)
The NorNed-cable will be an interconnection between The Netherlands and Norway. The license is given on the condition that the flow shall be decided based on implicit auction. This will be handled by the power exchanges APX and NordPool and the TSOs Statnett and TenneT. The final design of the auction has not yet been found. One of the discussed solutions is the **Multi Market Coupling (MMC)** which involves integration of many markets with a diverse set of local situations and requirements.
- Iberia; Spain – Portugal – Marocco
- Span – France

Since 2000 several organisations and other actors have been discussing a full EU market coupling. The Electricity Regulatory Forum in Firenze has had the subject on the agenda several times. The discussions have resulted in several proposals. European Transmission System Operators (ETSO) and Association of European Power Exchanges (EuroPEX) has presented a model, which is often referred to in the discussions. However several other models exist.

For day-ahead, a number of market-based solutions for handling congestion at the interconnections between markets are feasible (Eurelectric, 2005):

Flow-based market-coupling (**FMC**) as proposed by ETSO and Europex

In the proposal for flow-based market-coupling, the day-ahead allocation of capacity is done on power exchanges, via implicit auctions. This can co-exist with physical transmission rights

assigned for the month or year-ahead. In addition to this, flow factors calculated by the TSOs are used to represent the physical parallel flows that result from the scheduled commercial flows. This modelling allows optimal use of the physical capacities on the interconnectors concerned.

Open market-coupling (**OMC**) as suggested by EEX

The open market-coupling proposal requires the creation of a central auction office to centralise information, assign capacities and perform settlements. All market based methods for capacity allocation can be used with this model, i.e. explicit auctions, implicit auctions or even FMC. An example of an OMC is European Market Coupling Company (EMCC) that will coordinate the market coupling between Denmark and Germany from June 2008.

Market-splitting as done on Nord Pool

Market-splitting on the Nord Pool regional power exchange is currently applied for the day-ahead allocation of capacity on the borders between Norway, Sweden, Denmark and Finland, where the market rules are uniform throughout the area. Market splitting results in different price areas when there are congestions between the areas.

Potential development

The Nord Pool market splitting idea requires a harmonisation of the institutional set-up if the different power exchanges in Europe. This is not likely to happen in the near future, but could be a target in the long-run.

Therefore, it is likely that one of the two market coupling models (FMC and OMC) will be the preferred goal in the future. However, several actors are working for hybrid models, where explicit capacity auctions can co-exist together with a EU-wide market coupling.

The speed of the process is partly a political decision. Eurelectric calls for a rapid move to market-based allocation methods on *all* EU interconnectors as a way to increase efficiency in capacity allocation (Eurelectric, 2005).

Research and development

There is a need for analyses of market designs and different designs of auctions and what the different designs implies for the flexibility of the systems.

On the technologic side there is a need to develop market coupling mechanisms, system analysis and transmission models and TSO actions to ensure firmness of cross border commercial exchanges.

On the regulatory side, there is a need to coordinate regulatory and contractual matters.

On the EU – national level, there is a need to ensure compatible regional development.

Bottlenecks

Different grid codes and market rules have been created in the different countries. These are often based on the fuel mix or political priorities in the individual countries. E.g. rules at Nord Pool are based on Samkjøringen (co-ordination) of water based regions in Norway from the

late 1980'ies. Other power exchanges in Europe have rules which are designed for thermal based power and closed borders.

Agreement on a common structure for market coupling will require a certain coordination of the rules (the degree depends on the model chosen). Though the FMC is a manageable solution with minimum harmonisation requirements, it might be a challenge to get an agreement between the different countries.

Other issues

References

- [1] Energinet.dk, Systemplan 2007.
- [2] ETSO, List of data European TSOs need to pursue optimal use of the existing transmission infrastructure', December 2005.
- [3] ETSO, FMC-Flow-based Market Coupling, September 2004
- [4] ETSO, Cross-Border Electricity Exchanges in Meshed AC Power Systems, April 2004.
- [5] ETSO, Coordinated Congestion Management, an ETSO Vision', April 2002
- [6] Eurelectric, Position Paper Improving Interconnection Capacity Allocation. August 2005.
- [7] E.ON, <http://www.eonnetz-eltra-auctions.org/>
- [8] NordPool, <http://www.nordpoolspot.com/> samt <http://nordpoolspot.com/PowerMaket/The-Nordic-model-for-a-liberalised-power-market/Implicit-auction/>

Contact(s)

Klaus Skytte

Stine Grenaa Jensen

4.5 Ancillary services markets

Technical description

Main issues

Title	Ancillary services markets
Type of market	Physical market
Generation or demand	Generation
Transmission or distribution	Transmission / Distribution
Scale	
Supporting systems and procedures	Metering (instantaneous power, reactive power)
Main players	power producers

Brief description

A brief definition of ancillary services is given in Stoft [1]: The system operator must keep the system in balance, keep the voltage at the right level, and restart the system when it suffers a complete collapse. The system operator carries out these basic functions by purchasing what are called “ancillary services”.

With this definition, Stoft suggests to group the ancillary services as follows:

1. Real-power balancing (frequency stability)
2. Voltage stability (for customers)
3. Transmission security
4. Economic dispatch
5. Financial trade enforcements
6. Black start

The idea of a market for ancillary services as a new measure is to activate other costumers than the central power plants to provide the necessary ancillary services. From this point of view, the main focus is on the ancillary services 1 and 2, but also 6 can be considered. The costumers that can participate in an ancillary service market are first of all the remaining central power plants and the decentralised power plants including wind power plants. But also the demand side can participate, especially in the real-power balancing.

Energinet.dk defines ancillary services as “the joint name for various services to which TSOs require access in the operating phase in order to maintain the safe and stable operation of the electricity system” [2]. Power balancing / reserves is the main focus, but it will also be necessary to ensure reactive power and black start capability to be able to phase out central power plants.

Impact

Benefits (and drawbacks/limitations) to power system

The idea of a market for ancillary services is to avoid the dependency on central power plants. or on any specific type of power plants. If the distributed generation can supply the ancillary services, there would be less need to run central power plants in times with high wind speeds / low

market prices just. If the wind power can contribute to the ancillary services, it can reduce the need for other generation including decentralised CHPs in periods where there is sufficient wind to supply the system. In that sense, a real time market is optimal, but there is a trade off between market horizon and costs.

Dependence on other measures

There is a need for additional metering. Stoft [1] states (on page 21) that “it is possible, though expensive, to measure reactive power by individual customers”. Reactive power should be considered when investing in new meters to support demand side response.

The present measure is also linked to the demand response measures.

Environmental impact

Business issues

Status

Existing installations (examples if available)

Place	Time	Capacity	Function	Manufacturer	Ref
Denmark	2007		Daily market for ancillary services		[2]

Potential development

Real time markets for reserves and reactive power could ultimately phase out the dependency on having specific types of generators online.

Research and development

Bottlenecks

Other issues

References

- [1] Steven Stoft. Power System Economics. Designing markets for Electricity. IEEE Press. John Wiley & Sons. United States 2002.
- [2] System Plan 2007. Energinet.dk

Contact(s)

Poul Sørensen, poul.e.soerensen@risoe.dk.
Stine Grenaa Jensen

4.6.1 Demand response – hourly prices

Technical description

Main issues

Title	Demand response – hourly prices
Type of market	Physical market
Generation or demand	Demand
Transmission or distribution	Distribution
Scale	< 10 kW
Supporting systems and procedures	Interval meters needed
Main players	End-users, retailers, TSO

Brief description

Demand response is the voluntarily adjustment of electricity demand as reaction to a price signal. E.g. delaying demand in hours with high prices. End-users with an interval meter can already today sign up for a spot price type of tariff and adjust demand to hourly prices.

A spot price (day-ahead) is one relevant type of tariff, others are Critical Peak Pricing (CPP: a type of time-of-use tariff where a high price can be announced when needed), or time-of-use tariff (TOU: tariffs with a fixed time structure, e.g. day and night and often combined with a seasonal structure). In some countries pricing of maximum demand (effect) is also in use. Direct load control can also be considered as voluntary if the end-user allows a third party to control selected equipment (e.g. air condition, or electric heating).

Impact

Demand response can increase the demand in hours with low prices and reduce demand in hours with high prices. How this is done in practise can vary a lot, but often the change in demand is in the short time scale, e.g. delaying a demand for 1 to 3 hours. The impact can be pictured as short term electricity storage.

Demand response can also act by substituting energy source. In such case demand response in not only delaying the demand bur can remove the electricity demand completely or introduce new electricity demand, e.g. in the form of dump load in relation to low prices.

Benefits to power system

A higher degree of demand response than is known today can benefit the power system and the electricity market in many ways:

- Avoid investment in peak power plants with limited hours of operation.
- Improved utilisation of transmission lines (more hour with full use of capacity)
- Improved competition in electricity market (including reduced misuse of market power)
- Improved integration of wind power

These benefits are closely related to the “electricity storage” function of demand response.

Dependence on other measures

Demand response can be practised today by all end-users with en interval meter. All large end-users (>100.000 kWh/year) has an interval meter and can choose to buy electricity at a

hourly price. Many small end-users have or will have advanced meters (in 2008 plan for new meters covers 46% of all users). These will in most cases be able to record and transmit hourly electricity demand.

The current incentive for demand response is limited. The variation in the spot prices is low. This is partly because of the high share of hydro power in the Nordic system.

When using a spot price type of tariff the user is removed from the profiling system. The profiling system divides the hourly demand in an area to all end-users without interval meters. Leaving the profiling system is a benefit for some and not for others.

Business issues

Costs

Interval meters will eventually be installed to measure electricity demand for all users. The typical cost is in the order of 1.000 DKK per unit including all costs.

Also communication lines will be installed in all houses.

Many arguments indicate that demand response should be according to individual preferences, but should be automatised. The cost of such equipment can be critical if it is only used for demand response (e.g. in the order of 5-10.000 DKK), however if multiple purposes can be found (e.g. security or entertainment) the investment can be shared by the different purposes.

Status

Existing installations

All Danish end-users with an interval meter can buy electricity with hourly price, e.g. with a spot price. All users with a yearly demand above 100.000 kWh have an interval meter. Current level of demand response in Denmark is very limited. Examples of demand response exists in metal industry and demonstration projects have taken place in a cold store, a malt house, a water facility, greenhouses and shops.

Estimated potential for demand response	Potential (excl. electric heating)	Electric heating
Residential	100 MW	187 MW
Commercial, service and industry	385 MW	270 MW
Backup-generation	300 MW	-
Total	785	487
	1.242	

Source: [14, 17, 19]

Spot prices in Denmark are less volatile than those in Germany, but more volatile than in the other Nordic countries.

Research and development

Title	Country	Grant	Year
EFFLOCOM (24 houses with electric heating)	DK	Elkraft, Eltra	2003-2004
Demand response with electric heating	DK	PSO	2006-2009
Priselastisk elforbrug som reservekraft – et demonstrationsprojekt i gartneribranchen. DEG Green Team	DK	PSO	2006-2008
–			
Priselastisk elforbrug og elproduktion i industrien. Dansk Energi Analyse A/S	DK	PSO	2006-2008

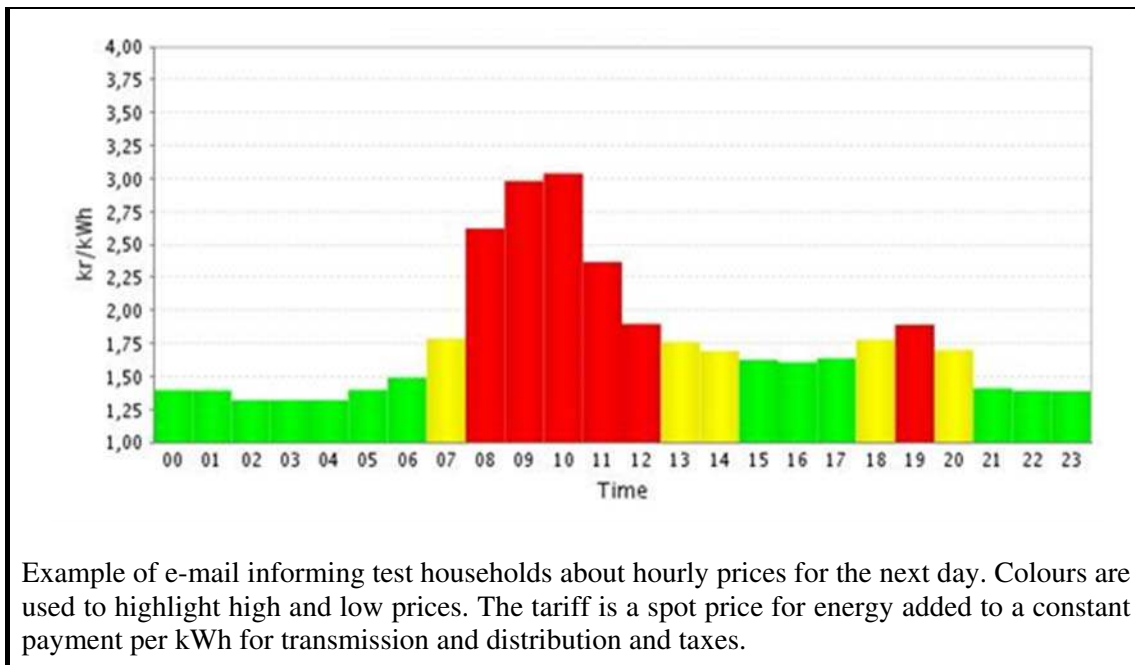
**Bottlenecks**

Demand response can be practised today by all costumers with an interval meter. The little use of demand response is related with the limits economic incentive as well as limited interest from the retailers of electricity.

For small costumers the investment in a new meter can be an obstacle. For small costumers with a interval meters the grid company must be interested in delivering interval data and the end-users must in must cases invest in automation equipment. Examples of automation equipment exist but are still quite expensive.

Dynamic prices for losses, nodal pricing and time varying taxes would increase the incentive for demand response.

References

- [1] Andersen, Jensen, Larsen, Meibom, Ravn, Skytte and Togeby 2006: Analyses of Demand Response in Denmark. Risø-R-1565(EN)

- [2] CRA International 2006: Assessing the value of demand response in the NEM.
- [3] Hawley 2000: Advanced Control of Energy Consumption, IEE Seminar on Practical Experience with Predictive Control, 4/1-4/10
- [4] Herter, 2007: Residential implementation of critical-peak pricing of electricity. Energy Policy 35 (2007) 2121–2130
- [5] IEA, 2007: Task XI: Demand Response Resources, www.demandresponseresources.com
- [6] Kofod and Togeby, 2004: Demand Response offered by households with direct electric heating. In Demand Response in Energy Markets, Conference proceedings, Nordic Energy Research, 26. November, 2004.
- [7] Pekka Koponen and Seppo Kärkkäinen, 2007: xperiences from spot-market based price response of residential customers. CIRED 19th International Conference on Energy Distribution, Vienna, 21-24 May 2007, paper 0508, 4 p.
- [8] Philip Lewis and Jessica Strombäck, 2007: Demand response: The missing link in the Scandinavian smart metering case. Metering International, Issue 3 2007, pp. 48 - 50.
- [9] Malaman, 2006: Automated meter technologies for demand response programmes. Autorità per l'energia elettrica e il gas. Italy.
- [10] Nordel, 2006: Enhancement of Demand Response. Nordel Demand Response Group.
- [11] Ontario Energy Board, 2004: Demand-Side Management and Demand Response in the Ontario Electricity Sector. March 2004. p. 25.
- [12] Oliva, 2008: Demand Response Programmes at Southern California Edison. Smart Metering Scandinavia 2008
- [13] U.S. Department of Energy, 2006: Benefits of Demand Response in Electricity Markets and Recommendations for Achieving Them, A Report to the United States Congress. Pursuant to Section 1252 of the Energy Policy Act of 2005. www.electricity.doe.gov/documents/congress_1252d.pdf.
- [14] Elkraft System (2001): Fleksibilitet i elforbruget.
- [15] Elkraft System og Eltra (2004 og 2005): Dansk TSO-handlingsplan for priselastisk elforbrug og Priselastisk elforbrug
- [16] Nordel (2005): Nordic TSOs' Action Plans in enhancing and monitoring Demand Response
- [17] Energistyrelsen (2006): Redegørelse om mulighederne for anvendelse af prisfleksibelt elforbrug i det danske elsystem
- [18] Energinet.dk (2008): Elmålere og kommunikation til nyttiggørelse af prisfleksibelt elforbrug. Rapport udarbejdet til Energistyrelsen af en arbejdsgruppe nedsat til formålet
- [19] Dansk Energi Analyse og Norenergi for Energinet.dk (2005): Priselastisk elforbrug hos de større elforbrugere.

Contact

Mikael Togeby, mt@eaea.dk

4.6.2 Demand as Frequency Controlled Reserve

Technical description

Main issues

Title	Demand as frequency controlled reserve
Type of market	Ancillary service market
Generation or demand	Demand
Transmission or distribution	Distribution
Scale	individually small in capacity but large when aggregated
Supporting systems and procedures	with/out communications for monitoring and business purposes; either market or regulation can be used for business model;
Main players	TSO, electricity end-users

Brief description

Demand as frequency controlled reserve is a technology that controls electricity demands in response to frequency signal to provide reserves to power systems, including continuous primary control reserve and fast disturbance reserve [1] [2] [3]. This technology utilizes frequency as the control signal that is universal in power systems and can be measured using a simple electronic circuit. The demands of interest for this technology include those from both industrial and domestic sectors, such as aluminium smelters, refrigerators and electric heaters [1] [2]. For monitoring or business purposes, the DFR can be implemented with or without communication system [2].

Impact

Benefits (and drawbacks/limitations) to power system

The DFR makes use of available recourses inside power system therefore reducing the need of extra generation capacity (for power balance control) and greenhouse emission accordingly. The r DFR is well distributed in low voltage network and thus no transmission congestion will be incurred when activated. Most importantly, the DFR will facilitate further integration of fluctuating renew energy into power systems. Besides, DFR will enable demand side participation into ancillary services business, thus contributing to realize full deregulation of power systems.

Not all demands are compatible with the technology. Thermostatically controlled loads are most appropriate for the DFR. With proper design, DFR can provide both up and down regulation services to the grid [1] [3]. The technology may but not necessarily lead to extra wear outs to the electric appliances [3].

Dependence on other measures

Extra investment may be needed for accurate monitoring for DFR. This monitor of DFR relies on using advanced information and communication technology, or statistical sampling method [2].

Environmental impact

No pollution for using DFR itself.

With DFR the need for frequency reserve from conventional resources will be reduced. Thereby the efficiency of the operation of conventional power plants will be improved and the environmental impact will be reduced.

Business issues**Costs**

Is it possible to give some idea about costs.

Issue	Value	Ref
Specific investment (M€/MW)	lower than traditional reserve, e.g. 20 Euro/kw	[2]
Availability (%)	Very close to 100 % for large population of DFR	
Technical lifetime (years)	Life time of appliances e.g. 10 years	[2]
Construction time (years)	0	
Fixed O&M (€/MW/year)	0	
Variable O&M (€/MWh)	0	

Manufacturers

no

Patents

Donnelly et al., 'Electrical appliance energy consumption control methods and electrical energy consumption systems', United States Patent 7,010,363, March, 2006 [4]

Status

Existing installations (examples if available)

New consumer appliances e.g. heaters and refrigerators can be manufactured with DFR function embedded, and existing appliances can be retrofitted to have DFR function. No large scale implementation of the technology is currently available, but several relevant demonstration projects have been run or under planning, e.g. Long Island Power Authority LIPAedge responsive load pilot project [5], Pacific Northwest National Laboratory (PNNL) GirdWise™ Northwest Demonstration Project in US [6] [7], and Danish PSO project on DFR Phase II: Practical demonstration [1-3] [8].

Place	Time	Capacity	Function	Manufacturer	Ref
US Long island	2003	Totally 24.9 MW reserve realized	234000 residential and small commercial air-conditioners, retrofitted with ComfortChoice™ thermostats	Carrier Corporation developed the ComfortChoice™ thermostat for responsive air-conditioners	[5]
US Olympic Peninsula, Washington	2005-2006	Total reserve achieved <1 MW	Clothes dryers in 150 homes and water heaters in 50 homes	PNNL with industrial partners	[6] [7]
Denmark including Bornholm	To start from late 2008	Total reserve achieved <1 MW	about 200 appliances, including electric water heaters and electric boilers etc.	CET with industrial partners from Ea Analyses, Danfoss Heating, Vestfrost. øskraft	[8]

Potential development

- a) Large customers (>100.000 kWh), e.g. aluminium smelters [9], waste water processing plant
- b) Small customers, household appliances refrigerators, freezers, electric water and space heaters, tumble driers, dish washers, and ovens etc.

Research and development

Title	Country	Grant	Year
Gird Friendly and GridWise program	US	US DOE Grant	From 2003
LIPAedge program	US	US LIPA Grant	From 2002
Danish DFR project Phases I and II	DK	Danish PSO Grant	From 2006
Dynamic Load [10-12]	UK		Since 2004

Bottlenecks

In general, the utility's acceptance of such services could be an obstacle in relation to effective monitoring of the service. This may be resolved with the development of ICT.

Other issues

References

- [1] Z. Xu, J. Østergaard, M. Togeby, and C. Marcus-Møller, “Design and Modeling of Thermostatically Controlled Loads as Frequency Controlled Reserve”, Proc. of 2007 IEEE PES General Meeting.
- [2] M. Togeby, Z. Xu, and J. Østergaard, “Demand as Frequency Controlled Reserve Phase I Work Package One- Backgrounds and Perspectives”, Nov, 2006
- [3] Z. Xu, J. Østergaard and M. Togeby, Project Report, “Demand as Frequency Controlled Reserve Phase I Work Package Two- Dynamical Simulation and Chosen Concepts”, Oct, 2007
- [4] Donnelly et al., ‘Electrical appliance energy consumption control methods and electrical energy consumption systems’, United States Patent 7,010,363, March, 2006
- [5] B. J. Kirby. “Spinning reserve provided from Responsive Loads”. Oak. Ridge National Laboratory. 2003;
- [6] PNNL (2003): Grid Friendly™ Controller Helps Balance Energy Supply and Demand. gridwise.pnl.gov/docs/pnnlsa36565.pdf
- [7] <http://gridwise.pnl.gov>
- [8] CET research proposal, “Electricity Demand as Frequency Controlled Reserve - Phase II: Practical demonstration”, Sep, 2007
- [9] Fingrid, “Maintenance of frequency” online at www.fingrid.fi/portal/in_english/services/system_services/maintenance_of_frequency
- [10] J. Short, and S. Leach, “Using smart appliances to provide peak-load management and increase the efficiency of the electricity network” EEDAL 06 International Energy Efficiency in Domestic Appliances Conference.
- [11] Short, J. and S. Leach (2006): Using smart appliances to provide peak-load management and increase the efficiency of the electricity network. EEDAL 06, International Energy Efficiency in Domestic Appliances Conference.
- [12] Dynamic Demand on line at <http://www.dynamicdemand.co.uk/index.htm>

Contact(s)

Mikael Togeby, mt@eaea.dk.

Zhao Xu, zx@elektro.dtu.dk.

4.6.3 Demand response – customer equipment

Technical description

Main issues

Title	Customer equipment for demand response
Type of market	Physical market
Generation or demand	Both
Transmission or distribution	Both
Scale	Small
Supporting systems and procedures	Interval meters, communication needs according to actual market (e.g. spot or ancillary)
Main players	Customers, DNO/TSO, power retailers

Brief description

A physical system enabling customers to take advantage of fluctuating power prices by changing between different heat supply regimes based on fuel and/or electricity.

An example for “domestic” use is shown below, where the original boiler is supplemented by a small heat-pump and two small cylinders for heat storage, one of which is equipped with an electric heater. For larger installations a micro-chp can be added in parallel with the boiler.

Heat can be provided from component or combination of components.

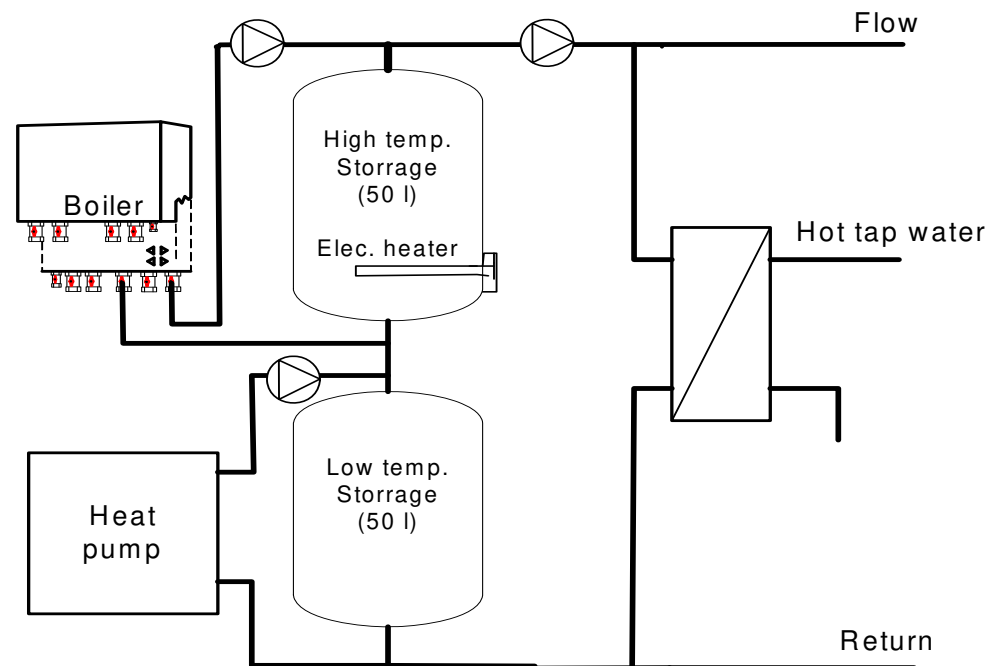

The system is governed by a control system choosing the most attractive producer or combination of producers based on electricity and fuel prices.

As the example below shows, the relative attractiveness of the different heat sources changes constantly.

DK1*, Samfundsmæssige forbrugerpriser, varme

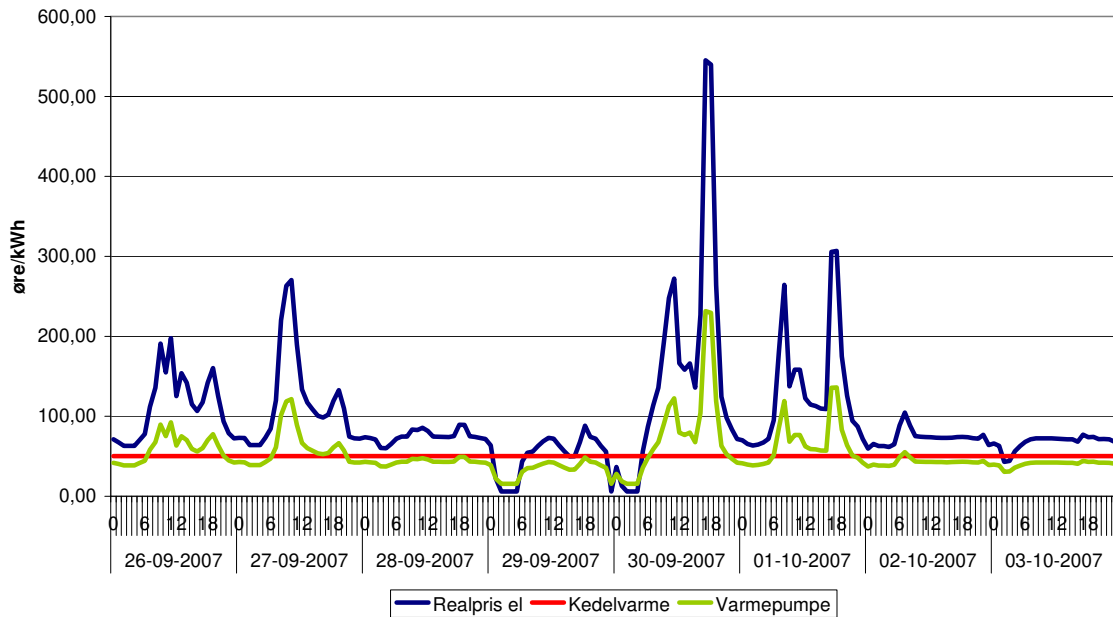

And the systems choice of heat producer changes accordingly

DK1*, Flex-system
Prisstyret fordeling af varmeproduktion (smf)

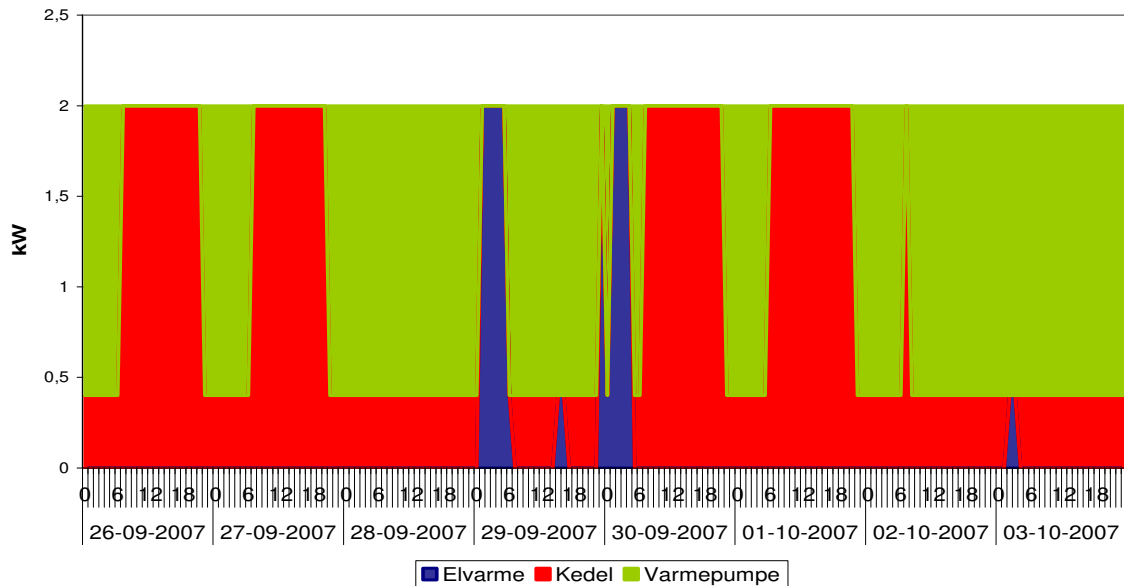

Impact

Benefits (and drawbacks/limitations) to power system

Heat demand constitutes a very substantial part of the total energy demand. Response based on usefull heat has an equally substantial potential as it only limited by total heat demand (summer less, winter more) and is free of the time-limitations normally associated with

“customer response”. It is capable of absorbing – and increasing the value of – huge injections of renewable production, e.g. wind-power, and do this with great predictability because of the very high number of individual systems.

The physical components are characterised by extreme response capability, as shifting from one regime to another will last from less than a second to a few seconds. For that reason, the utilisation of this potential for power balancing is solely decided by the quality of metering, communication systems and general system intelligence. The scope can be framed by two extremes: with “low resolution” being simple response to “spot” prices (one message/day, one hour interval meters), and “high resolution” being in-time balancing, which will call for a different control regime with embedded intelligence and online communication.

Ultimately, such systems can be used to achieve a desired balance in any system/network/part of network down to the individual installation, thus keeping the utilisation of transmission systems and networks at optimum and the need for back-up power at a minimum. It should, however, be appreciated that even the most simple “spot-response” will provide very substantial socioeconomic benefits by economically optimised integration of different energy resources .

The system is open to the inclusion of new elements as they may appear (e.g. hybrid cars)

Seen from the supply network, the consequence of the system’s function is an “added consumption profile”, which happens to be a mirror image of network electricity price. This is a very attractive function as high price reflect shortage of capacity, while very low price reflects “excess production”.

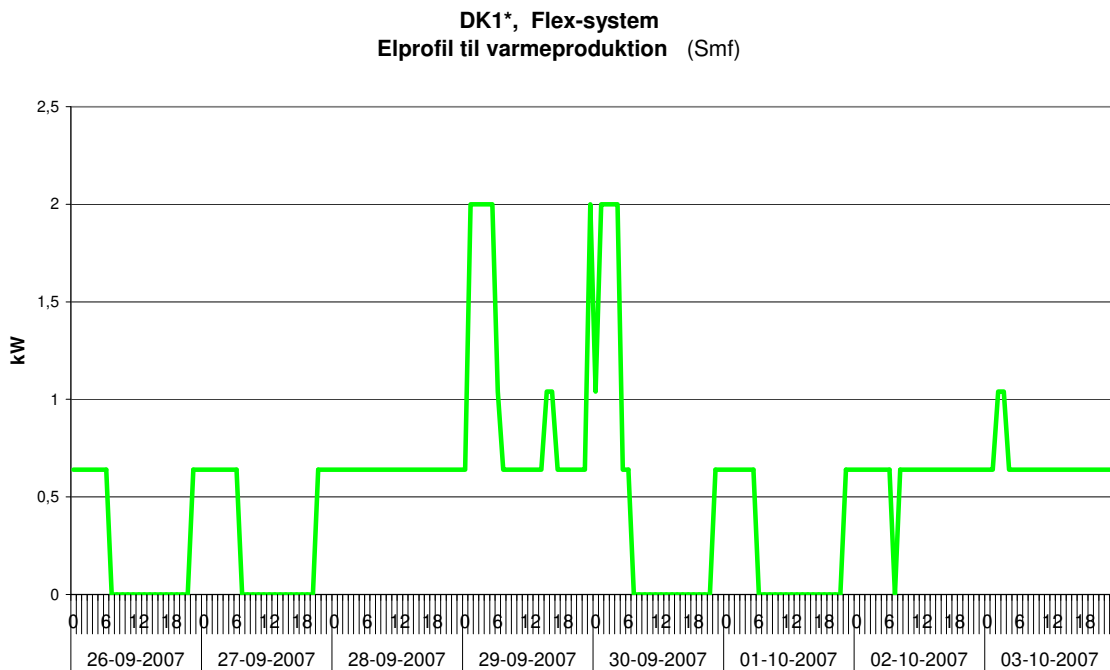

Dependence on other measures

Meters & communication. Ideally, it would be nice if somebody could come up with a “petrol pump” type meter capable of:

- Receiving an in-time price,
- passing this price on to customer equipment
- and counting money as well as Wh’s.

None of which should overstretch anybody’s imagination.

Environmental impact

Substantial reductions in the use of fuels, emissions of greenhouse gasses, particulates etc. by increased ability to absorb and optimise the utilisation of fluctuating injections from renewable sources, thus enabling very high shares of e.g. wind-power in the total energy supply.

Business issues

Costs

Ordinary off-the-shelf –products (except micro-chp), at least one element present in any heating system.

Customer price indications:

- Water cylinder with electric heater: 100€/kWe
- Small heat pump: 1.000€/kWe

Manufacturers

Products available from innumerable manufactures in the heating business

Patents

Status

Existing installations (examples if available)

At least EC Power has installed a substantial number of systems with micro-chp, heat-pump(s), boiler & electric heaters from 1998 onwards.

In the absence of real-time prices, these systems have been operating on assumed fixed-price relations.

We are just now changing the system to work on “NordPool spot” –based prices for one customer.

Potential development

For system function: Unlimited. The ultimate high resolution, in-time balancing scenario is best described as an all-including, totally fluid “organic” energy supply system. Less will do for a while.

For customer equipment: The new competition across traditional energy boundaries will bring more efficiency, lower prices and new products, partly by tougher competition in general, partly by introducing new producers. E.g. the car industry, where extreme competence and capacity in research, development & manufacture is very likely to revolutionise the price level on (and quality of!) power production equipment, in particular micro.

Research and development

Ongoing at EC Power, others??

Bottlenecks

Lack of networks with appropriate meters & communication, lack of demonstration project of relevant size.

Other issues

References

Contact(s)

Jens Otto Ravn Andersen, jora@ecpower.dk.

Mikael Togeby, mt@eaea.dk.

5. Control and IT measures

The control and IT measures work package focused on the following tasks and measures:

- Communication: IEC 61850 and 61400-25 standards;
- Protection: multi-agent based wide-area protection system;
- Interactive meters: Energy Flow Control (EFC);
- Wind farm control:
 - o Active power control
 - o Reactive power control
 - o Low Voltage Ride Through
 - o Grid synchronization and Monitoring,
 - o Black start support,
 - o HVDC connection,
 - o Island operation support,
 - o Optimal production control,
 - o Overload capability,
 - o Virtual inertia ;
- Fluctuation forecasts:
 - o Wind Power Point Forecasting;
 - o Wind Power Forecast Uncertainty,
 - o Load Forecasting,
- Micro production power control: Local Grid Support;
- PMUs;
- State estimation : Real time state estimator;
- Dynamic Transmission Line Rating Systems;
- Virtual Power Plant based on Emergency Generation Assets.

The above control and IT measures are considered very important tools for dealing with ever changing and rapidly growing energy market combined with increasing renewable energy capacity, which makes monitoring, control and easy communication between different systems very important. A basic requirement for easy communication between different systems requires that communication is vendor independent, which can be guaranteed by standards like IEC 61850 and 61400-25.

A phasor measurement unit (PMU) is a device that provides synchronized measurements of real-time phasors of voltages and currents along with a measurement of the frequency. PMUs provide new

opportunities for power system operation and control and possible applications for Denmark should be investigated.

Figure 1 shows a schematic overview over both existing and potential applications of PMUs. All of them are very important applications for the future power system operation in Denmark.

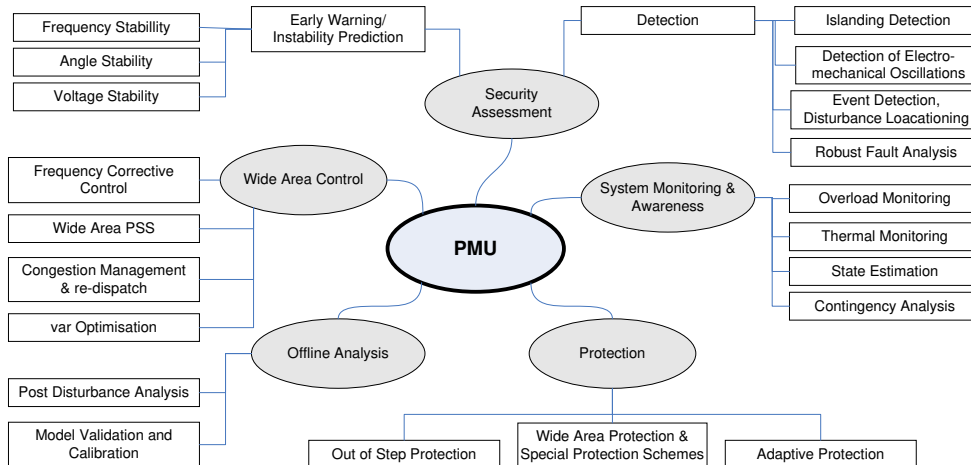

Figure 1: Schematic view over both existing and potential applications of PMU data.

With increasing penetration levels of wind power and micro generation in Denmark, wind farms as well as micro-generation such as solar panel (photovoltaics), micro wind turbines, fuel-cells, micro CHP based on gas-turbines with an installed power < 10 kW will have to become more active in supporting power system operation and control. It is expected that new features for wind farms and micro generation will play a significant role in a power system with large wind share. For wind farms such new possible features are grid synchronization, black start support, island operation support, virtual inertia and production control. It is recommended that those technical options are further investigated and possible coordination of these measures are investigated. A similar recommendation can be given to further R&D projects related to wind forecasting systems as well as load forecasting systems and possible improvements of the relevant weather forecasting tools.

Another measure that will play a significant role in the future is the Energy Flow Control (EFC), which has the functionality not only to measure electricity, gas, water or other energy sources, but also to optimize the usage of the energy sources, see also Figure 2 for an overview of the concept. It is recommended that the possible role of EFC in the future power system is further evaluated.

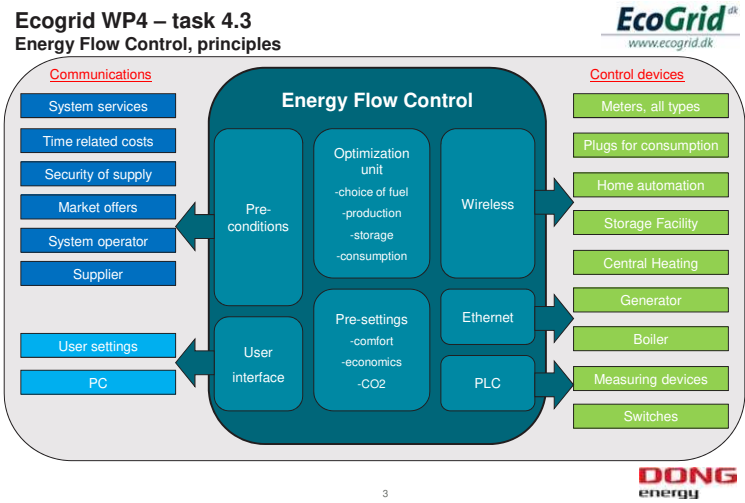

Figure 2 Principle of Energy Flow Control

Finally, Virtual Power Plant (VPP) based on emergency generation assets as well as dynamic transmission line rating systems have been investigated. The VPP based on emergency generation assets would be used as reserves in case of power system emergency situations and has a significant potential in Denmark. It would follow a VPP design similar to brief outline discussed in work package 2. The dynamic transmission line rating is also a very promising measure to increase the transmission capacity; however, it seems Energinet.dk is already considering outside temperature and wind speed when determining transmission capacity, hence the benefits might not be as large as in other countries. It is, however, recommended that the benefits of a dynamic transmission line rating are evaluated compared to the existing approach used by Energinet.dk

5.1 Communication standards IEC 61850 and IEC 61400-25

Technical description

This technical description will give an introduction to 61850 and 61400-25 standards. These are the state of the art within communication networks and systems in substations and wind power plants. A short introduction to security issues is also given as the standards are developed to operate in a distributed system which may have to operate in insecure environments such as the internet.

Brief description of 61850.

Substation automation is essential in order to maintain an efficient and reliable electrical infrastructure. The IEC 61850 standard is developed to make this automation interoperable and cost-efficient. The general title of the IEC 61850 standard is Communication networks and systems in substations [1]. The standard consists of the following parts:

- ***IEC61850-1 Introduction and overview.***
- ***IEC61850-2 Glossary.***
Explains terms and abbreviations used throughout the standard
- ***IEC61850-3 General requirements.***
Specifies system requirements with emphasis on the quality requirements of the communication network.
- ***IEC61850-4 System and project management.***
Specifies system and project management regarding the engineering process life cycle of overall system and the integrated developers environments, and the quality assurance.
- ***IEC61850-5 Communication requirements for function and device models.***
Describes all required functions in order to identify communication requirements between the technical services and the substation, and between the integrated developers environments within the substation. The goal is interoperability for all interactions.
- ***IEC61850-6 Substation automation system configuration description language.***
Specifies the system configuration description language file format for describing communication related integrated developers environments parameters communication system configurations, function structures, and the relations between them. The purpose is to exchange integrated developers environments capability description, and substation automation system descriptions between the integrated developers environments' engineering tools and different system engineering tools.
- ***IEC61850-7 Basic communication structure for substation and feeder equipment:***
 - IEC61850-7-1 Principles and models.**
Introduces modelling methods, communication principles and information models used in IEC61850-7. Also, detailed requirements and explanations are given regarding

the relation between IEC61850-7 and the requirements from IEC51850-5.

IEC61850-7-2 Abstract communication service interface.

Presents the abstract communication service interface providing abstract interfaces describing the communications between a client and a remote server, such as interfaces for data access and retrieval, device control, event reporting and logging.

IEC61850-7-3 Common data classes.

Specifies common attribute types and common data classes related to substation applications. The common data classes specified, are for instance, classes for status information, measured information, controllable status information, controllable analogue set point information, status settings and analogue settings.

IEC61850-7-4 Compatible logical node classes and data classes.

Specifies the compatible logical node names and data names for communication Between integrated developers environments.

IEC61850-8 Specific communication service mapping.

IEC61850-8-1 Mapping to Manufacturing Message Specification (ISO/IEC 9506 Part 1 and Part 2).

Specifies how time-critical and non-time-critical data may be exchanged through local area networks by mapping abstract communication service interface to Manufacturing Message Specification

IEC61850-9 Specific communication service mapping.

IEC61850-9-1 Serial unidirectional multidrop point to point link.

Specifies the specific communication service mappings for the communication between bay and process level and a mapping of the abstract service for the transmission of sampled values. These are specified on a serial unidirectional multi drop point to point link.

IEC61850-9-2 Mapping on a IEEE 802.3 based process.

Defines the Specific Communication Service Mapping for the transmission of sampled values according to the abstract specification in IEC61850-7-2.

IEC61850-10 Conformance testing.

Specifies how a substation automation system should be tested to ensure conformance with the IEC61850 standard.

Brief description of 61400-25.

The IEC 61400-25 series is a specialized version of defining and standardizing a unified communication for monitoring and controlling wind power plants. One aim is to enable systems from different vendors to mutually communicate.

The IEC 61400-25 series is an extension of the previous IEC 61850 series of standards, which in general defines communication networks and systems in substations. IEC 61400-25 does not

simply replicate IEC 61850 but reuses the definitions which in general apply to all power systems [1, 2].

The standardization expands over the information modelling of the target system and the communication protocol for communicating the data encapsulated in the information model. As a result of this approach, the standard addresses the domain by separating it into three main categories of interest which together encompass all the important aspects of the communication and control of wind power plants. The different main categories are as follows [3, 6, 9]:

- **Part 25-1** **Overview and general principles.**
- **Part 25-2** **Information model.**
- **Part 25-3** **Information exchange model.**
- **Part 25-4** **Mapping to communication profile.**
- **Part 25-5** **Conformance testing.**

Security issues in 61400-25-3

IEC 61400-25-3 defines the security aspects for the standard and how to solve it in general, but how it is handled specifically is completely up to the individual supplier.

One supplier might simply use a secure line, and therefore remove any security aspects of the service itself, while another might want to use a public ISP where the service related traffic must be secured by the service itself. This calls for a solution where security is built on top of the communication as a separate layer in a modular fashion easy to add, remove or change on demand

In TC 57 [4] a proposal has been presented in which a security model has been suggested.

Another aspect of security is access control. Access control has the duty of ensuring that only authorized individuals can gain access to the data. How and what the security includes is defined by the service mappings (SCSM). In IEC 61400-25 the minimum requirement for access control is only defined as the need for supplying a valid username and password to gain access. This ensures that only people with a valid password can gain access to the system. Different users might have the rights to perform different actions.

Impact

Benefits with use of 61850 standard.

The IEC 61850 standard has a number of benefits compared to previous standards, often referred to as legacy standards. These can be described as artefacts of the eighties' - the time in which many of them were developed.

The communication protocols of these legacy standards were developed for serial link technology and were later adapted to run over TCP/IP-Ethernet [5]. From the start, one of the objectives of the legacy protocols was to account for bandwidth limitations by minimizing the number of bytes sent. Many of these protocols were proprietary and thus communication between devices from different vendors was not always possible.

From the start, the IEC 61850 standard was designed to operate over modern networking technologies. Interoperability is ensured by the standard and many features are included which would be impossible to include using previous standards.

Compared to legacy standards, a few of the specific benefits of the IEC 61850 standard include the following features:

- Every element of data is named using descriptive strings whereas legacy protocols often use storage location and register numbers to identify data.
- The communication protocol supports:
 - Generic Object Oriented Substation Event (GOOSE) which is an abstract data model mapping in the communications.
 - Generic Substation Status Event (GSSE).
 - Sampled Measured Values (SMV).
 - Many other services not supported in legacy protocols.
- The standard includes a Standardized Configuration Language (SCL) for substations which uses Extensible Mark-up Language (XML), which is a widely used mark-up language which facilitates sharing of structured data across platforms, typically over the Internet. XML files are used for the configuration of a device and removes ambiguity issues in previous standards.

Benefits with use of 61400-25 standard.

Wind power plants have over the years steadily gained a bigger and more dominant position in the power generation industry. Each vendor has their proprietary solutions of controlling and monitoring the products supplied.

In today's ever changing and rapidly growing energy market, monitoring and easy communication between different systems, are essential. Through this communication the current state of the individual wind plant can be controlled and monitored when required, and counter measurements can be enforced if needed, in order to meet the changing demand for energy and to maintain the stability of the distribution system. It is vital that the overall dispatching systems are able to control the energy generation from a wind farm on demand in order to meet the fluctuations in the energy consumption. A common way to achieve this is a vendor independent approach.

As the complexity of the power distribution network increases, methods for efficient analysis, monitoring and coordination of the network control become essential. This in turn requires a highly efficient and dynamic control strategy for the power system network. Several organizations have addressed this issue in manners where the main objective has been to develop communication standards for interconnecting electric power generation systems.

The project team behind 61400- 25 standard has been formed by various members from many companies e.g. Vattenfall, Energi E2, Hydro Tasmania, Statkraft, Vestas Wind Systems, GE Wind Energy, Siemens Wind Power, Schwarz Consulting Company, Garrad-Hassan, natcon7, ECN Wind Energy, kk-electronic, SecondWind, EnerNex, KC Associates, Ecotecnia, Robotiker, Ingeteam and Q-Technology. The following companies have been represented in the team during the working period: Enercon, Nordex, RePower and Gamesa.

Dependence on other measures

Business issues

Costs

Manufacturers

Patents

Existing installations (examples if available)

Potential development

Research and development

Bottlenecks

Other issues

Since the standards are being developed in a distributed system which may have to operate in insecure environments such as the Internet there are a number of security issues which have to be considered. Since it is impossible to ensure that the physical connection is not being tapped it must be assumed that all traffic can be recorded by another party. The traffic can subsequently be analyzed and replayed at a later stage or even be altered. Moreover it is hard to be certain that the party at the other end of the communication channel is really the party with whom the communication is intended to be performed.

It is important to look at security both in the backend integration and in the communication between the client and the substation or wind plant. In many cases sensitive data might be replicated in local databases or on devices which makes this a potential point of entry for hackers. As the old saying goes: “the system is only as strong as its weakest link”. It is important that the final solution anticipates all potential security breaches and that security is considered in all phases of the development to ensure a secure result. An overview of the possible threats should be presented in a threat modelling document which is not a part of the standards.

References

- [1] <http://www.61850.com/>
- [2] <http://www.iec.ch>
- [3] Andreas K.Olsen, Baris Özdil Prototype for a IEC 61400-25 Compliant Generic Server.
- [4] Frances Cleveland IEC TC57 Security Standards for the Power System’s Information Infrastructure – Beyond Simple Encryption.
- [5] R. E. Mackiewicz. Overview of iec 61850 and benefits. Power Systems Conference and Exposition, 2006. PSCE '06. 2006 IEEE PES, pages 623–630, 2006.

- [6] Prototype of Generic Server for Wind Power Plants Using IEC 61400-25 Standard. K. Olsen, B. Ösdil, B. Poulsen, K. O. Helgesen Pedersen. International Journal of Distributed Energy Resources. Volume 3 Number 4 October- December 2007 ISSN 1614-7138.
- [7] Reporting and logging in compliance with IEC 61400-25 Umut Korkmaz, July 2007
- [8] Yener, Bülent *Internet Security*, John Wiley & Sons, Inc 2003. Found on 2008-01-07 at
<http://www.mrw.interscience.wiley.com.globalproxy.cvt.dk/eot/articles/eot278/sect4-fs.html>
- [9] <http://www.iec.ch/cgi-bin/procgi.pl/www/iecwww.p?wwwlang=E&wwwprog=sea22.p&search=iecnumber&header=IEC&pubno=61400&part=&se=&submit=Submit>

Contact

Bjarne Poulsen, bjp@imm.dtu.dk

5.2 Description of a multi-agent based wide-area protection system

Development of protection technologies

The majority of the protection principles were developed within the first 3 decades of the last century which can be found in Fig.1.

- In the late 1960's, Rockefeller proposed the application of a centralized substation protection system based on a centralized computer system
- In the late 1970's, research into non-power system frequency fault detection techniques to increase the speed of the relay response
- In the 1980s and 90s, new means to advance power system protection, specially 'Adaptive Protection' and the Artificial Intelligent (AI) based protection techniques.
- In recent years, high frequency transients, new protection principles and techniques, growth in signal processing power, modern communication technology [1]

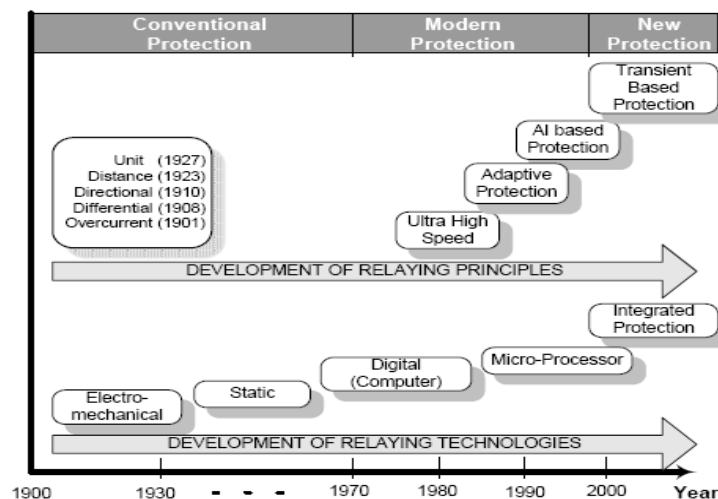

Fig.1. History of relay development [1]

However, the power system become more complex to operate and to control, and thus more vulnerable to a disturbance. Therefore, the protective system will meet more and more problems and challenges:

- Most of the protective system designs are centered around individual components.
- System-wide disturbances in power systems are becoming a frequent and challenging problem.
- The occurrence of major disturbances in power systems requires coordinated protection and control actions to stop the system degradation, restore the normal state, and minimize the impact of the disturbance
- Local protection systems are often not capable of protecting the overall system

On the other hand, the development in communication and measurement accelerates the occurrence and applications of wide-area protection, a kind of advanced protections based on wide-area measurements.

Multi-agent and wide-area measurement

Multi-agent

With the application of DAI (distributed artificial intelligence) in power system, the protection system based on MAS (Multi-agent system) can improve performances of existing protection. An agents can operate continuously and spontaneously to implement a series of computing entity or program by itself according to environment [2].

Wide-area measurement

As the dynamic behavior of the system can be determined by wide-area synchrophasors, system-wide synchronizing phasor measurements have good potential for applications in power systems, such as state estimation, adaptive relaying, online instability prediction, fault recording, etc.

As for the sources of timing signals, GPS (Global position system) can provide continuous precise timing at better than 1-ms level, which makes it very suitable for applications in synchronizing phasor measurement systems [3]. They are placed on some selected locations, to measure real-time positive sequence (and negative and zero sequence quantities, if needed) voltages and currents of a power system with precise time synchronization, and then send these data to a center for comparison, evaluation and other further processing. A synchronizing signal is used in the PMU (Phasor Measurement Unit) to tag the measurements.

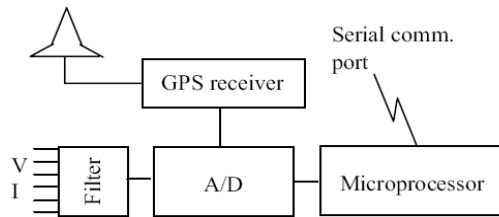

Fig.2. Phasor measurement unit [3]

Architecture

MAS consists of a group of intelligent agents, and usually is structured in the format of layers, a typical structure is illustrated Fig.3.

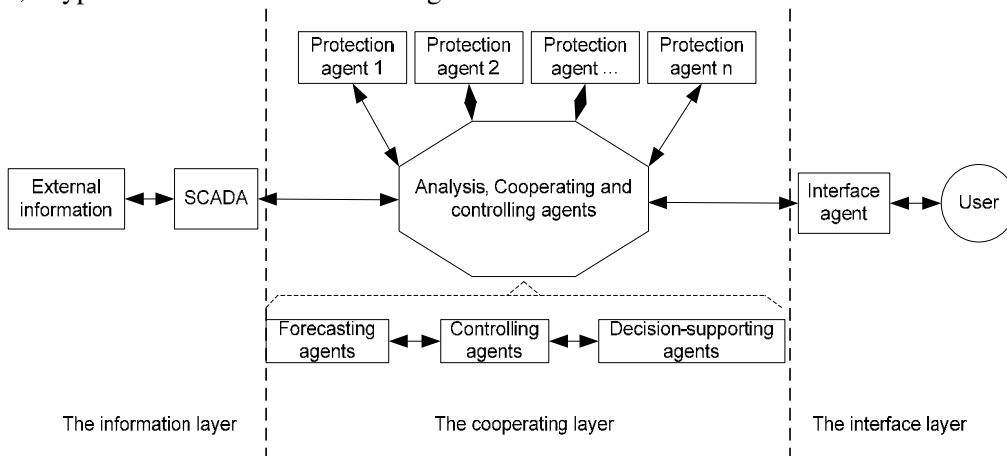

Fig.3. The architecture of MAS

There are three layers:

5.2 Description of a multi-agent based wide-area protection system

The information layer— external information collection. SCADA (Supervisory Control and Data Acquisition) collects data from the system, including network parameters and the operation information. Then the information layer agents deliver the information to the agents in the cooperating layers.

The cooperating layer— the agents analyze, detect and infer the information with each other and send the information rapidly to the decision-supporting agents by certain telecom language.

The interface layer— combines users with computer based on graphics and it performs the data management and operations in program. The intelligent interface understands the actual intention as soon as possible and then takes proactively to implement operation [3] [4].

Features

MAS not only alters the attributes of each agent but also enhances the intelligence of agent through mastering social activity by communicating with each other with a special language. MAS covers many domains, such as system organizing structure, the telecom, coordinating and collaborating,, dynamic features, etc [4][5].

The attributes of MAS	Function	Comments
Autonomy	control interior states and motion without any help	the basic attribute of agents
Cooperation	cooperate with other exterior agents to accomplish complicated tasks with certain language	one of the important attributes and embodies its activity
Intelligence	learn in the surroundings and cooperation and improves itself	Furthermore, agents can apperceive environment and proactive in time
Adaptation	open to others and adapts itself to conditions	extend, limit or modify local knowledge and grasp proper time to finish its objects by itself through inducing actions

Dependence on other measures

Communication

A reliable and fast communication system is an indispensable infrastructure of a wide-area protection system and MAS. To build a fast, robust and reliable communication network, several very important factors to be considered are media, communication protocols, and topology of the network.

Currently, a combination of analog and digital communication systems, consisting of power line carrier, radio, microwave, leased phone lines, satellite systems, and optical fiber, is often utilized in protection systems. The fiber optics is best choice for its good characteristics [7].

Communication protocols are an intrinsic part of modern digital communications. The most popular protocols, which are suitable for wide area protection and control, are the distributed network protocol (DNP), Modbus, International Electrotechnical Commission Standard IEC870-5, and the Electric Power Research Institute (EPRI) universal communications architecture/multiple messaging system (UCA/MMS) [8]. TCP/IP is probably the most extensively used protocol and will undoubtedly find applications in wide-area protection.

The typical communication architecture is a combination of trees, rings and meshes, with a ring as the backbone. Self-healing capability is a distinctive feature of a ring topology, and it could greatly increase the reliability of the communication system. The main protocols used in an optical fiber system are synchronous optical networks (Sonet/SDH) and the asynchronous transfer mode (ATM). Wide-band Ethernet is also an alternative in non-backbone systems, and

5.2 Description of a multi-agent based wide-area protection system

the most widely used Internet Protocol (IP) is employed as a network transmission protocol [7] [8].

Intelligent Electronic Device (IED)

Definition: An Intelligent Electronic Device (IED) is a term used in the electric power industry to describe microprocessor-based controllers for power system equipment, such as circuit breakers, transformers, and capacitor banks.

Function: IEDs receive data from sensors and power equipment, and can issue control commands, such as tripping circuit breakers if they sense voltage, current, or frequency anomalies, or raise/lower voltage levels in order to maintain the desired level.

Common types of IEDs include protective relaying devices, load tap changer controllers, circuit breaker controllers, capacitor bank switches, recloser controllers, voltage regulators, etc [9].

Comments: Protection relays being manufactured these days are primarily IEDs. Based on microprocessor technology, a single unit can perform several protective, control, and similar functions. Whereas, before the microprocessor technology, a single unit would contain only one protection function, if several protection functions were required, the one would have to combine a number of different units of protection relay [10].

A typical IED can contain around 5-12 protection functions, 5-8 control functions controlling separate devices, an autoreclose function, self monitoring function, communication functions etc. Hence, they are named as Intelligent Electronic Devices. Some recent IEDs are designed to support the IEC61850 standard for substation automation, which provides interoperability and advanced communications capabilities [11].

Benefits

Compared with the traditional protection, the scheme is more reliable and less vulnerable, and it provides power grid intelligence protection with an effective method.

- By employing the concept of agent theory (MAS), an agent-based protection system can be developed to extend the coverage of protection to dynamic protection zones.
- The agent in the protection system is an active entity. It continuously perceives the changing of the environment with traditional protection computing, and uses the integrating rules to find the fault of a system.
- The collaboration of multi-agent in the protection system is very important. It gives elaborate designs of the agent and improves the ability and adaptability of whole power system.
- WAMS is based on the best synchronizing clock in wide area provided by GPS and can carry out real-time monitor for the operating state of the power system.
- Local protection is to clear the fault, while Wide Area Protection or System Protection is used to save the system from a partial or total blackout or brownout in operational situation.
- Wide area protection and control system (WAPCS) work together with the data from PMUs (also agents) for stability assessment and stabilization algorithms, provide a reliable security prediction and optimized coordinated actions so that potential large area disturbances can be mitigated or prevented.

There are some exiting applications of wide-area protection and control systems, such as southern Sweden's SPS against voltage collapse, and Florida's FALS, employ SCADA for information gathering that allows a time frame only of several seconds for actions [3][8][9][10][11].

Bottlenecks

- The proposed scheme may not be justifiable to extend the proposed protection system to the radial distribution networks, which can be protected effectively with traditional protections with retrofit cost considered.
- It may not be appropriate to implement upon extra-high-voltage or ultra-high-voltage long lines which require high-speed tripping of all terminals for stability purposes, as the long time delay over long distance broadband network communication is not acceptable.
- All the wide-area protection schemes are based on global information and their performance depends on the reliability of communication systems.

Up to now, only simulation work has been done for higher speed wide-area protection systems to demonstrate its validity, and few practical applications reported [2][4][8][9].

Conclusion:

The rapid developed MAS (Multi-Agent System) technology has provided a new way for building large distributed protection and control system, which has many applications, such as the industry control, information system, etc.

Meanwhile, wide-area protection is currently a research hotspot in power systems, and appears very promising for wide industrial applications. Much effort has been made in the past 10 years or so, and significant progress has already been achieved. However, there is still a big gap between current research status and industrial applications. In fact, only some simple forms of wide-area protections have been applied in a few power systems around the globe.

Reference:

- [1] Z Q Bo, J H He, X Z Dong, B R J Caunce and A Klimek, "Integrated protection of power systems", Power engineering society general meeting, June 2006.
- [2] Jinai Zhang, Qianjin Liu, "The application of a multi-agent technology in relaying protection", South China University of Technology.
- [3] A. G. Phadke, "Synchronized phasor measurements in power systems", IEEE computer applications in power, vol. 6, issue 2, Apr. 1993.
- [4] Su Sheng, "Agent-based self-healing protection system", IEEE transactions on power delivery, vol. 21, no. 2, April 2006.
- [5] Jing-hua Chen, "Study on adaptive protection relay system based on multi-agent", Proceedings of the Fourth International Conference on Machine Learning and Cybernetics, Guangzhou, August 2005.
- [6] Xiaoyang Tong, "The cooperative Modeling of wide-area protection multi-agent based on organization", 2006 International Conference on Power System Technology.
- [7] Y. Z. Xin and C. Y. Lu, "Analysis of data network technology architecture for power systems", Automation of electric power systems, vol. 24, no. 21, Nov. 2000.
- [8] M. Begovic, D. Novosel, D. Karlsson, C. Henville, and G. Michel, "Wide-Area protection and emergency control", Proc. Of the IEEE, vol. 93, no. 5, May 2005.
- [9] X. J. Zeng and Z. G. Guo, "New development of relay protections—wide-area protections", Popular utilization of electricity, no. 8, Aug. 2004.
- [10] A. B. S Mohamed Rayees, "Substation automation techniques and future trends", Innovations in information technology, 2007.
- [11] Cong W., Pan Z. C. and Zhao J. G., "A wide area protection system and division of protection IED associated area based on petri net", Transmission and distribution conference and exhibition, Asia and Pacific, 2005 IEEE/PES.

Contact

Bjarne Poulsen, bjp@imm.dtu.dk.

5.3 Interactive Meters

- Concept of Energy Flow Control (EFC)

Technical description

Brief description

The core of Ecogrid phase 1 is a survey of possible new measures for maintaining the Domestic system flexibility and security. This requires a mobilization of new resources, even at end-user level. The potential for more active customer participation in the system requires end-user control possibilities. The emerging new technologies in the field of information and communication technology, provides new business opportunities for the users of the system.

Measurement is all known today and can be done by several types of meters within water, gas, electricity etc. But the controllability is not present today. A lot of research within demand response and other related topics has been done, but the breakthrough is still in front of us. It is a good idea to install remote metering facilities at all customer sites, but we need to prove that the effort in doing this is worth taking. **Remote metering is not the key to a more flexible system, but it's a tool to make the flexible system to work.**

The principle for the Energy Flow Control (EFC) has the functionality not only to measure electricity, gas, water or other energy sources, but also to optimize the usage of the energy sources in accordance with the needs from System, Society, Market and End User. This also includes local production as the unit is seen placed at both customer site and at local minor production sites. The EFC is a 'concept, it can be either all in one unit, partly centralized as well as a complete centralized system. The Interactive Meters is a component somewhere in this concept. This description is about a concept that should be able to fulfill the future demands, as it's flexible, consists of mostly well known technology used together in a new way and has the cost potential. The threat against it is the need for standardization within the different interfaces. This is not a detailed design description of meters, but how to use them.

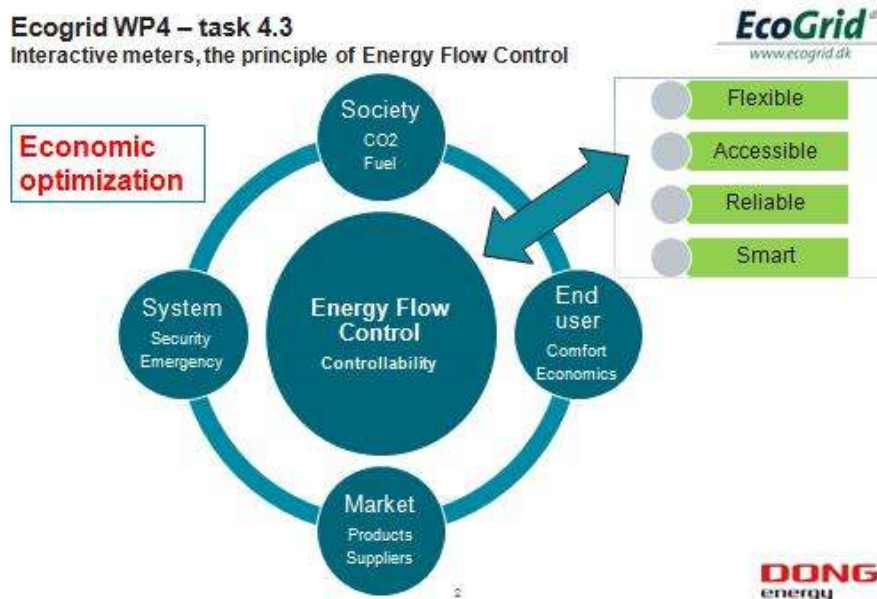

Figure 1 Optimization wheel, Energy Flow Control

Issues to explore in phase 2 of EcoGrid

No doubt that some kind of remote readable meter is a tool to make the future flexible energy system and market working. A precondition to optimize the use of energy sources and to get the CO₂ reductions needed. In the **phase 2 of the EcoGrid project** there should be focused on some of these issues:

Regarding **Interactive Meters** in the context of Energy Flow Control:

1. Is the future of Interactive Meters a remote readable meter with extended functionalities as we see the vendors doing it today, **or**
2. Is the future of Interactive Meters deeply related to the energy optimization of the system and the system flexibility and therefore need to be an integrated part of that system that makes a concept and standardization work needed?

And with respect to the **optimization architecture**:

- An optimization unit, an **Interactive Meter**, an Energy Flow Controller, which controls all at a decentralized level and has access to all data necessary? Need to be a part of Smart Home!
- A **Smart** meter that controls household demand / production and report measurements and system data to a centralized system? May be a part of Smart Home!
- A simple **Remote** readable meter that only does measurements, system optimization and control all done centralized by use of internet as example? No Smart home link!

And the **customer comfort**:

- The energy optimizations has to work easily and automatic, if the services and the benefits should be used by the customer. How do we manage to make it easy for all of us to explore all the possibilities and benefits for system, market, society and ourselves?
- Integrations to developments in the Smart Home area. We need to follow and connect with that development. Else it will be a competition in getting the customers attention and not a synergy!

EcoGrid WP4 – task 4.3
Energy Flow Control, principles

EcoGrid^{dk}
www.ecogrid.dk

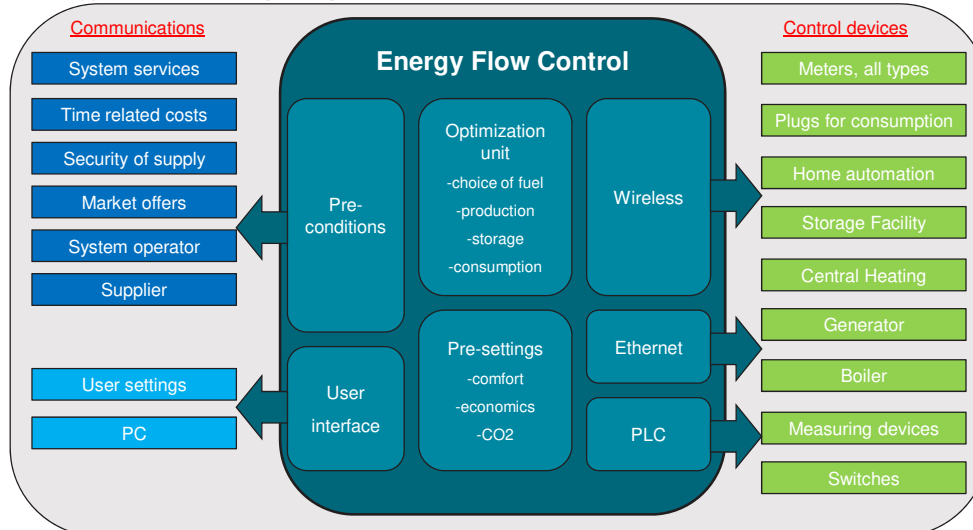

3

DONG
 energy

Figure 2 Principle of Energy Flow Control

And the **regulatory framework**:

The regulatory framework means a lot within the future for the remote readable meters or even more complex versions. It's very important that the meters installed is the **right type to fulfill the future demands** from the electricity and gas system as well as the market services. Else a need for reinstallations could be a risk which gives a high increase in costs!

- **Technology consequences** have to be a part of the regulatory framework. Today the installed meter based is mostly old fashioned, without electronic components and software. When interactive meters are installed we both have electronics, software and communications and data warehousing. This gives a need for frequently operations with software updates, lower life times of hardware, new communications standards to implement, data systems to install, maintaining and all the handling of data to all operators in the market. All gives operational costs that are not part of the business today!

In the following part the long list of functionalities and things to consider is listed. All this, and probably even more issues, has to be considered, when the concept and principles for Interactive Meters and Energy Flow Control shall be discussed.

Grid connection

The Smart, Remote or Interactive Meter must be placed at the customer or plant connection point to the grid, in some cases even with several meter systems as slave units. If it's a complete decentralized Energy Flow Control concept, the Interactive Meter will work as a master. For example one master unit with electricity meters for each generator at a local production plant or each of a solar panel, gas fired unit etc. at a household.

Normally it will be a low voltage (400 V or 600 V) connection or in case of larger local productions units at medium voltage (1 kV, 6 kV or 10 kV).

The Danish energy association has to develop a set of rules on which connection can be done, as much of it as possible based on international standardization. There is a substantial work to be done on this subject.

Status

By today there are descriptions and criteria's in the area of local production, solar cells etc. Also today's types of meters are described. The work is described at:

<http://www.danskeenergi.dk/Netteknik/Elmaaling>

Substantial work within handling and reliability of new electronic and remote meters has been done during the last years. See [4]

Technical data

Functionalities

To ensure an optimization between end user, market, system and society many parameters has to be taken into account. The possibilities of functionality are wide. This is a 'long list' of functionalities and benefits to discuss in relation to the Energy Flow Control concept, and then whether it's to be implemented in the Interactive, Smart or Remote Meter or should be supported in other system components:

- Society

5.3. Interactive meters

- Energy saving unit as well as carbon burden reduction of energy stream – gas, electricity, heat and cooling
- Optimization between energy sources – environmental and cost as well as combining with transportation fuels
- Providing information for authorities and researchers
- Pushes market flexibility
- End User (customer)
 - Services for monitoring and improving energy efficiency of end use consumption and dispersed generation
 - Customer information feedback
 - End use energy management
 - Link to Smart Home, home automation, remote control of appliances by customer
 - Customer services from suppliers
 - Safety, security, telemedicine, social alarm services
- System (including DSO and TSO)
 - Demand response for network operation support
 - Capacity and peak load limitation
 - Ancillary services such as frequency controlled reserve, voltage and reactive power control
 - Connect, disconnect, limit load remotely
 - Load analysis, modeling and forecasting
 - Settlement and billing
 - Fraud detection
 - Meter management
 - State estimation of power distribution networks
 - Monitoring of power quality and reliability
 - Analysis of failures and preventive maintenance
- Market
 - Demand response for electricity market
 - Active price-signaling based on interface with customers
 - Tariff setting (Time of Use, Maximum Demand, Seasonal)
 - Tariff of energy stream – gas, electric, heat and cooling
 - Virtual Power Plant, embedded renewables and cogeneration
 - Improving competition and efficiency in energy markets
 - Prepayment

The requirements need to be established in order to guarantee minimum services for customers and reduce investment risk for meter operators. The use of technical standards both within and between countries needs to be promoted and third party access to metering data should be possible.

Measured quantities by the meter

All utility meters purchased for billing purposes in Europe must comply with the Measuring Instruments Directive. This specifies the minimum accuracies required for meters of different classes. It also specifies the quantities that meters should measure: **kWh for active energy electricity and heat and m³/s or kg/s for gas**. Purchasers may specify other quantities but, under the MID, it is not legal for governments or national bodies to specify them. The Measuring Instruments Directive was implemented in October 2006. This set the minimum essential requirements for utility metering. The MID directive only addresses the metrological aspects of the meter. For example setting the minimum accuracy levels and which quantities should be measured. However, it is illegal under European law for member states to impose additional requirements above the essential requirements of the MID. This will constrain the ability of Governments or National regulators to mandate technical requirements for smart metering. A series of harmonized standards have been published by CEN and CENELEC that can be used to demonstrate compliance with the MID. It should be noted that for electricity meters, the MID does not include reactive energy within its scope. However, purchasers of meters are free to request reactive energy metering. Other quantities that can be measured are:

- Electricity: Reactive energy, Instantaneous power, Power factor, Voltage, Each phases, Maximum demand
- Gas: Flow, pressure, Energy, Maximum demand, Heat/Cooling

All of these quantities can be useful as part of a smart metering scheme. In addition, all of the measured quantities can be recorded over different lengths of time; ranging from 10 / 15 minutes, 1 hour up to 1 month.

Energy Consumption Analysis Software

Many of the listed functionalities require a MMI for the user. This deals with software and displays that have to draw data from a number of different sources (including different kind of meters) and combine these in useful ways. This will raise a number of issues of which will be the need for a common understanding of data meanings and units.

Smart Home

To ensure controllability there is a need to line up with the requirement for smart homes applications. Smart homes devices should be able to cooperate with the Energy Flow Control concept and access the available data or to perform the full functionality.

Smart homes technology, like Smart Meters, has many applications and is difficult to define. The BEAMA Smart Homes Group (see references) has divided the various applications into four categories:

- GREEN SMART HOME
Allows the householder to reduce their impact on the environment by providing energy usage information, control strategies and automated operation of products
- SAFE AND SECURE SMART HOME
Enables householders to be more secure in their homes via security products allowing for increased user interaction, more remote controls and monitoring, internet use and other communications methods
- ASSISTED LIVING SMART HOME
Has features enabling householders to enjoy, and remain longer in their homes, irrespective of age and/or disability
- LIFESTYLE SMART HOME
Possesses products with functionality to provide lifestyle benefits, including intelligent entertainment systems and on-line on-demand services

Of these the first, Green Smart, is most relevant for the Ecogrid project, but the other aspects have to be taken into account as they all will influence each other and will be expected by the customer.

The key elements of the green smart home are the heating control system, individual appliance controls, house sensor networks etc. Primarily this allows heating controls to minimize the energy input to the heating system whilst satisfying the comfort requirements of the occupants. It can also minimize the cost of running the heating system or appliances where energy costs vary predictably; such as an off peak power tariff. The smart homes components can all be linked together to optimize the operation of the heating system by, for example, reducing the temperature in unoccupied rooms, either pre-programmed or in response to occupancy sensors. The operation of appliances can be controlled to minimize the peak house power demand or to exploit time of day tariffs. This is exact an important part of the Energy Flow Control concept.

Energy Flow Control functions, that could be a part of the Interactive Meter:

- Enable a secure, 2-way link between the smart homes and meter systems. Such links must be controlled so that only authorized parties can make this connection
- Provide access to consumption data from the meter, identifying different energy streams and measures
- Provide access to tariff and other energy descriptions; price, carbon burden etc.

5.3. Interactive meters

- Support communications between the smart homes system and the remote RESC, ESCO or other authorized party
- Support future innovation in both smart home and smart meter

It is clear that the nature of smart home technology is rapidly evolving. This must be allowed for in the development of protocols for smart homes and smart metering. In all likelihood, the way to achieve this flexibility is to provide undefined communications channels between the systems that can be used for future needs.

Some good links within the Smart Home subject is the organizations CECED, CENELEC, Smart Homes Group, TAHI, Homeplug, Home Alliance and Elsparefonden.

Communications

For the communication part there are many considerations. This part only gives the headlines of some of them. It might be most challenging part of defining the future EFC and the units taking part of it. Some important functional requirements are:

- Bandwidth
- Speed of Response
- Data packaging
- Network Topology
- Peer to Peer, Star/Concentrator or Mesh

All communication networks must consider the following issues:

- Universality
- Reliability
- Long Term Availability

The communication from the centralized base to the household fall into the following categories:

- Leased Line
- PSTN
- Optical Fibre
- Wireless WAN
 - GSM
 - GPRS
 - 3G
 - WiMax
 - Low Power Radio
 - Power Line Carrier (PLC)
 - ADSL / Broadband

At the household some LAN technologies should be considered:

Wireless system

- Wi-Fi
- Bluetooth
- Zigbee
- Z-Wave
- Proprietary Systems

Wired system

- Power Line Carrier
- Twisted Pair
- Optical fibre

The design chosen depends 100% on the actual demand and required functionality of the operator. But it will have an important impact on the business case!

Safety issues

The control functions need to ensure safety and security of supply. This must be addressed when the concept and units is designed.

Impact

Benefits to power system

There are a number of benefits for the different stakeholders within this subject. Work has not calculated numbers on them but concentrates about listing specific areas that could be calculated. Sharing of costs and benefits of smart metering is a major challenge in the unbundled electricity market.

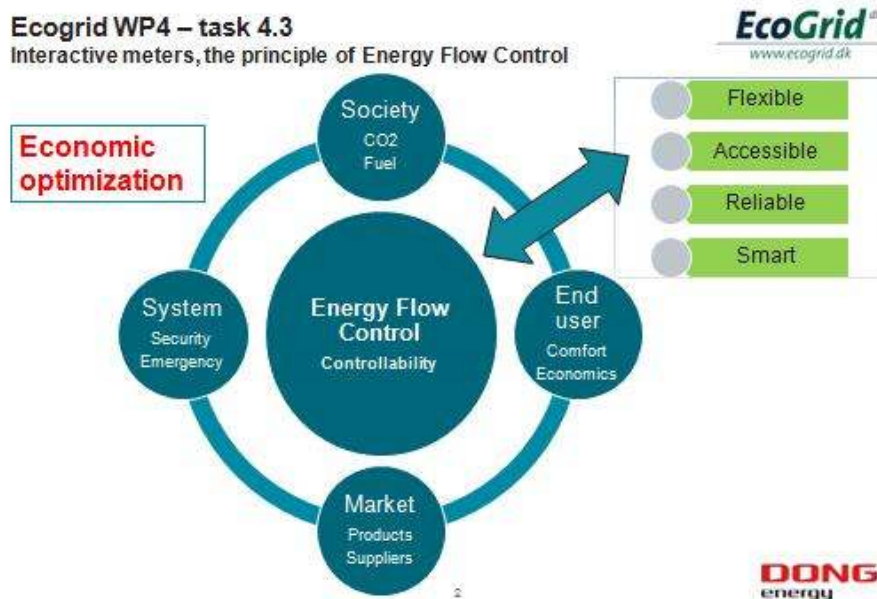

Figure 2 Optimization wheel, Energy Flow Control

The benefit areas are covered by the list of functionalities in the technical part (page 4). The different categories are: Potential benefits from customer point of interest, Potential benefits from society (and environment) point of interest, Potential benefits from market point of interest and Potential benefits from system point of interest. Specific benefits within this areas can be calculated when system functionality is decided.

Distribution grid perspectives

Seen from the distribution grid company this development gives major challenges for the traditional way til build and operate grids. Load curves and characteristics will change, customers will act by themselves, power production comes from the low voltages side etc. A lot of challenges will rise over short or long time, the companies must be ready.

Dependence on other measures

As the Energy Flow Controller relates to the market and systems tasks in Ecogrid phase 1, there is a need for discussions in a later phase. Within the meter area it's mostly the communication part that might benefit from other tasks concerning IT and Control issues.

Specific relations to other measures are:

- Demand Response – customer equipment

Environmental impact

There are a few things to concern about regarding the Interactive Meters environmental negative impact:

- Energy usage – the EFC and the metering system must use less power than it claims to save?
- Need for battery back-up - battery life and the use of batteries would create issues over energy usage, recycling, replacing?
- Master of optimization – is it the economics for the customer or is it less environmental impact?

But on the other hand, if we succeed making an Energy Flow Control system that enables the benefits for all stakeholders, and makes it an easy controllable way, there are tremendous benefits in front of us to public utility.

Business issues

Costs

The cost for a meter with starts at about €100 including modem facilities and installation. In addition to that is the infrastructure costs needed to collect data to the central hub. In addition to that the costs for the central IT-platform who do the data handling and data exchange within the market. If it's coordinated with Smart Home functionalities there might be some synergy between those 2 subjects.

No further analysis done in this stage of the project, as specifications still is uncertain and therefore difficult to estimate cost of.

Benefits on Interactive or Smart Metering

Benefit estimates are needed to justify and design investments in smart metering. The direct benefit part of the Interactive or Smart Meters will traditionally be:

- Reduced operation costs
- Increased Data reliability and security.
- Improved customer service

These will normally not be sufficient to cover the investments. But when Smart Metering is needed because of Market and System functionality, the direct benefits is add on.

Standardization

Standardizations is an important issue, but too complex to discuss in details in this document. This is a brief pro and con:

Benefits of Common Standards Approach

- Meter and associated equipment would be manufactured in larger volumes resulting in lower costs. Larger markets would also encourage more innovation from hardware and software developers

5.3. Interactive meters

- By avoiding the need for each member state to investigate and develop its own approach, less Regulatory and government cost would be required.
- By repeating a common approach across Europe there would be a significant benefit arising from shared experience
- A common approach would also support European Commission objectives for free market in services. There is a danger that the development of incompatible national schemes will restrict market access to local companies that have the necessary knowledge to operate the schemes
- The costs for new entrant companies would be lower if they could replicate a common approach in different countries

Disadvantages of Common Standards Approach

- A common approach across Europe would require the agreement of a majority of Member States on any new standards. Given the need to account for local conditions in any such standard, the difficulty of reaching such agreement should not be underestimated.
 - Once a common approach has been agreed it will be harder to introduce innovation, simply through the greater numbers of parties involved. Also, a number of national schemes will provide more opportunity to try different approaches than a single international scheme
 - The variety of national conditions will result in making any common system complicated. For instance it must include data entities as required for all member states and allow for all commercial models
 - A fundamental stage in developing a common approach would be the agreement on common system architecture. Whilst many different local arrangements can be accounted for within the detail of the common approach, it is not possible to bring together fundamentally different system architectures.
-

Status

Existing installations

There are a high number of operators working with Smart-metering or Interactive metering. There are a large number of references on the world-wide web, some of them can be seen in the documents in the part References of this format. It's just to seek them. But no one has started really to think about the Energy Flow Control in general, time is to come.

Research and development

Dependent on strategy, there is a need for development for concept and control together with data communications, if the customer should be able to optimize his usage of the market in respect of the system needs. Especial in the area of optimization between energy sources used for heating, transportation, household etc. There are many activities running throughout Europe, but there is a need for coordination and this could for the Danish part be phase 2 of Ecogrid.dk together with Ecogrid.eu for the European part. This is proposed to be in scope for phase 2 of Ecogrid.dk.

Bottlenecks

Major bottlenecks are:

- Standardization within all communication and data protocol issues
 - Decision of who to control the optimization, centralized or decentralized >< Economics or Environmental?
-

Other issues

There are several producers in the world which produce systems for the grids. Grid Agent Distributed Energy Management and Control System was developed by CSIRO Energy Transformed Flagship (Australia) is used for fully automated control of appliances. That is working on developing a distributed intelligence platform to aggregate and control on-site. The platform and its capabilities are based on intelligent agent technology, particularly the installation of software to create an intelligent device situated in customers' homes and premises. Software agents sense, compute, switch and communicate with each other across the premises to automatically switch the load and on side generators according to an energy savings policy decided by, and optimized for, each customer. An agent monitors the energy consumption of each appliances or piece of equivalent in the premises and communicates to the rest of the agent system its capability to turn on or off and/or shed load. As system needs change, new price signals or other cost functions can be communicated to the local agents, and depending on customer preferences that steer these agents, they can choose how they will contribute to the overall response.

In Denmark the TSO Energinet.dk operates a large project working with cell structures to operate the distributions system more active when system needs help to avoid break downs. This project communicates in several levels and has as perspective that the communication platform can be used to ensure a more dynamic market for production and load; all controlled in smaller areas called cells.

References

The main references are attached to this document.

- [1] ESMA Smart Metering Application Guide 2008, draft January 2008
- [2] ESMA Smart Definition of Smart Metering and Applications and Identification of Benefits, Summary
- [3] ERGEG report about Smart Metering with a Focus on Electricity Regulation
- [4] Paper: CIRE2007_0396_paper_elmaaling.pdf

Contact

Lars Bai Jensen, larje@dongenergy.dk

5.4 Overview of wind farm control

Graphical overview

The figure below provides an overview of the described wind farm control measures, relating them to main grid connected operation or island operation

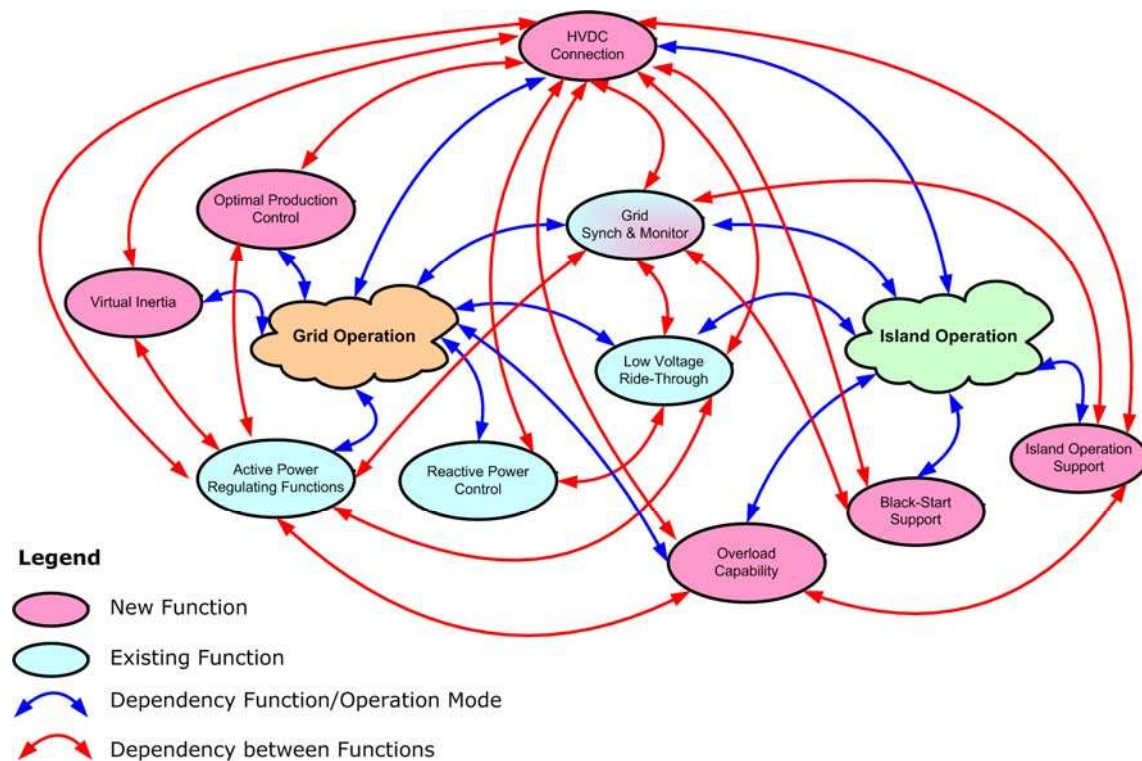

List of measures

Existing Functions

- Active power regulating functions
 - some required in grid codes
 - some implemented in WT and/or WF Control
- Reactive power control
 - required in grid codes
 - different specifications (e.g. P/Q, P/PF, etc) -> difficult for benchmarking
 - different limits in control
- Low Voltage Ride-Through
 - different requirements in grid codes
 - fault duration
 - voltage dip
 - recovery time

- reactive current injection during fault (e.g E-On) -> critical issue
- Grid Synchronization & Monitoring
 - standard methods
 - new methods shall be considered for supporting New Functions and Operation Modes

New Functions

- Virtual Inertia
- Optimal Production Control
- Overload Capability
- Black-start Support
 - WT level – requires a power converter based WT
 - WF level –
- Island Operation Support
 - includes voltage and frequency control
 - requires advanced grid synch. and monitoring methods
- HVDC Connection
 - not used on large scale for wind power
 - may increase the connectivity & the control capabilities for wind power
 - high interconnectivity with Existing or New Functions

Contacts

Florin Iov, fi@iet.aau.dk

Paul Bach Thøgersen, pbt@kk-electronic.dk

Poul Sørensen, poul.e.soerensen@risoe.dk

Thomas Ackermann, thomas.ackermann@ieee.org

5.4.1 Wind Power – Power Regulating Functions

Technical description

Main issues

Title	Wind Power – Power regulating functions
Type of market	Regulation power and grid control
Generation or demand	Generation
Transmission or distribution	Transmission and Distribution
Scale	100% of future wind turbine power (3000 MW)
Supporting systems and procedures	Existing control systems
Main players	TSO, DSO and wind farm owners

Brief description

Specifications for power regulations of wind farms connected to transmission level are given in [1]. The following specifications for the active power and power regulation shall be noticed:

- it shall be possible to limit the wind farm production to a random set-point value in the range of 20÷100% of rated power
- it shall be possible to set the regulation speed at upward and downward regulation in the interval 10÷100% of rated power per minute.
- The wind farm controller shall have different type of regulations as shown in Table 1. In order to avoid unwanted interference between these regulating and constraint functions a priority ranking is assigned for each of them. These active power control functions shall be agreed in detail with the system operator.
- Wind farm shall provide to system operator an estimation of the possible production

Table 1. Power regulating function for wind farm connected to transmission system according to [1].

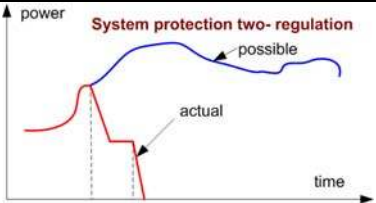
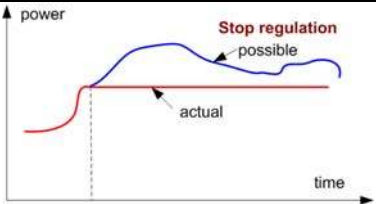
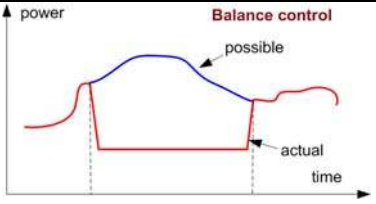
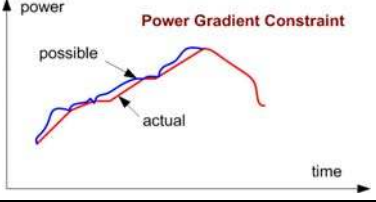
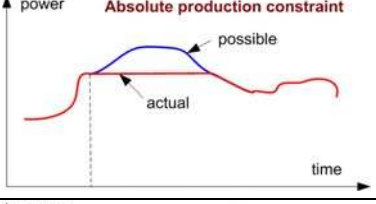
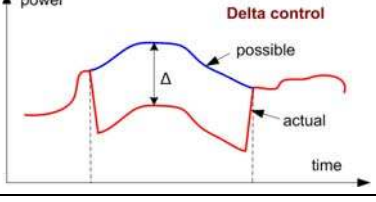
Control type	Priority	Objective	Primary control objective
System protection	1	Protection function that shall be able to perform automatic down-regulation of the power production to an acceptable level for electrical network. In order to avoid system collapse it should act fast.	
Frequency control	2	All production units shall contribute to the frequency control.	Automatic control of power production based on frequency measurement to re-establish the rated frequency.
Stop control	3	Wind farm shall keep the production on the actual level even if it is an increase in the wind speed	
Balance control	4	The power production shall be adjusted downwards or upwards in steps at constant levels.	
Production rate	5	Sets how fast the power production can be adjusted upwards or downwards	
Absolute production limit	6	Limit the maximum production level in the PCC in order to avoid the overloading of the system.	
Delta control	7	The wind farm shall operate with a certain constant reserve capacity in relation to its momentary possible power production capacity.	

A possible characteristic for frequency control without and with 50% down-regulation is presented in Figure 1.

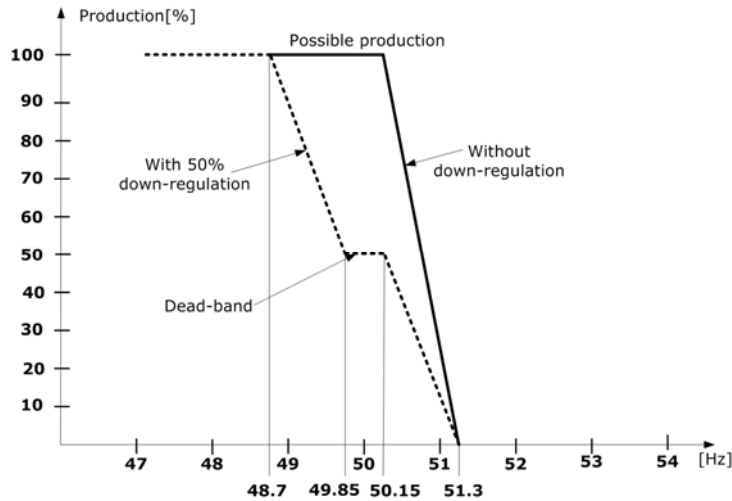

Figure 1. Possible frequency control characteristics with 50% down-regulation.

Maximum Ramp rates for power control are high (10 to 20 % per second) compared to other generators.

Impact

Benefits (and drawbacks/limitations) to power system

Increase value of wind power. Reduce the need for other spinning reserves.

Dependence on other measures

Accurate dynamic grid measurement data (voltage, frequency and perhaps even phase) must be available, both at Wind Farm as well as Wind Turbine control system level.

Wind Farm/Turbine overload capability will increase the control range during periods with high wind speeds (with full/rated Wind power available).

Environmental impact

Reduce the need for fuel consuming spinning reserves

Business issues

Costs

Manufacturers

Implemented in Horn Reef wind farm controller

Patents

Status

Existing installations (examples if available)

Place	Time	Capacity	Function	Manufacturer	Ref
Horns Rev		160 MW		Vestas	
Nysted		165 MW		SIEMENS	

Potential development

Research and development

Title	Country	Grant	Year
Operation and control of large wind turbines and wind farms	Denmark	PSO Elkraft FU2102	2002

Bottlenecks

Other issues

These regulating functions are addressed to wind farms connected to transmission system. They can be also applied to distribution system in the future

References

- [1] Energinet - Grid connection of wind turbines to networks with voltages above 100 kV, Regulation TF 3.2.5, December 2004, pp. 25.

Contacts

Paul Bach Thøgersen, pbt@kk-electronic.dk

Florin Iov, fi@iet.aau.dk

Poul Sørensen, poul.e.soerensen@risoe.dk

Thomas Ackermann, thomas.ackermann@ieee.org

5.4.2 Wind Power – Reactive Power Control

Technical description

Main issues

Title	Wind Power – Reactive power control
Type of market	Regulation power and grid control
Generation or demand	Generation
Transmission or distribution	Transmission and Distribution
Scale	100% of future wind turbine power (3000 MW)
Supporting systems and procedures	Existing control systems
Main players	TSO, DSO and wind farm owners

Brief description

Different requirements for reactive power control exist in the grid codes.

Denmark

According to [1] the reactive power flow between the wind turbine including the transformer and the electrical network must be calculated as an average value over 5 min within the control band shown in Fig. 1. This chart is valid for WT's connected to voltages below 100 kV.

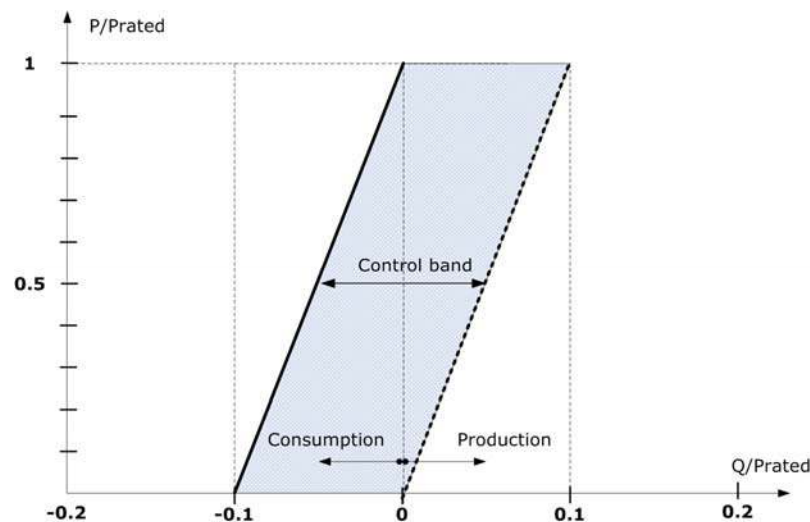

Fig. 1. Requirements regarding the reactive power exchange for WT connected to the Danish grids with voltages below 100 kV.

An identical control characteristic for reactive power is required also for wind farms connected to grids with voltage levels above 100 kV [2]. However, some additional requirements are provided in [2]. Three types of control shall be implemented in this case:

- MVAR control – shall provide the desired MVAR exchange in the reference point for the entire wind farm;
- Voltage control – shall provide the desired voltage in the reference point by means of reactive power control for the wind farm;

- Reactive power control based on minimum requirement – the reactive power of the wind farm shall be kept at the minimum allowed value in the PCC.

Ireland

Voltage control is required for Wind Farm Power Stations (WFPS) connected at 100 kV bus [3], [4]. These power stations shall have a continuously-variable and continuously-acting Voltage Regulator System (VRS) with similar response characteristics to a conventional Automatic Voltage Regulator and shall perform generally as described in BS4999 part 140 or equivalent European Standards.

The voltage step emissions limits are according with the IEC standard 61000-3-7/1996 Assessment of Emission limits for fluctuating loads in MW and HV power systems.

The slope setting of the VRS shall be capable of being set top any value in the range 0% to10 %.

The reactive power capability of all kind of WFPS is summarized in Fig. 2.

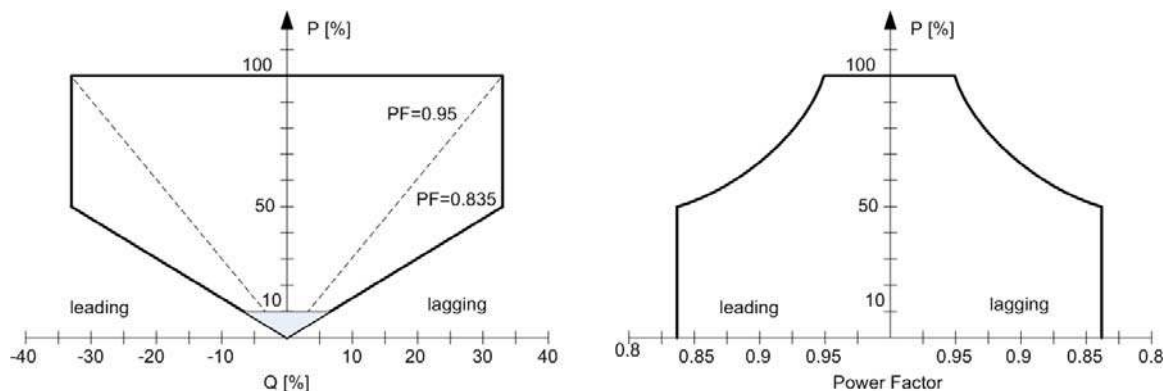

Fig. 2. Reactive Power Capability of Wind Farm Power Stations in Ireland.

Germany

The reactive power control for wind power connected to the transmission system is defined in [5] and [6].

All generating units shall provide in the connection point without limiting the active power output the range of reactive power provision as shown Fig. 3

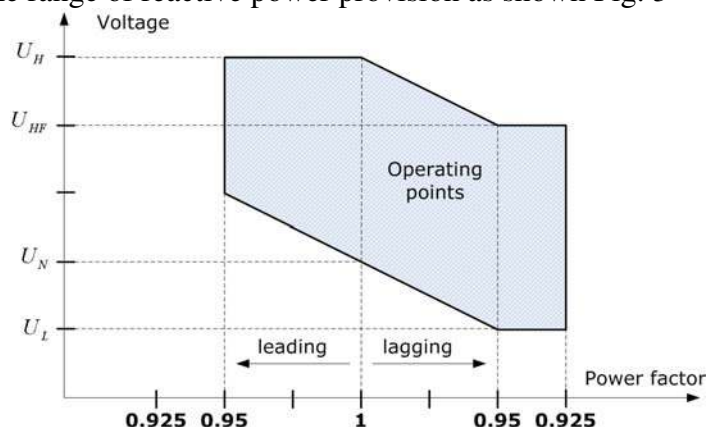

Fig. 3. Reactive power provision of generating units without limiting the active power output.

The reactive power exchange is defined by E-On through a set-point value given as power factor, reactive power level or voltage level (with a tolerance band if necessary). A new operating point of the reactive power exchange shall be achieved at the grid connection point after no more than 1 min.

Great Britain

All generating units other than synchronous ones with a Completion date after 1 January 2006 [7] should be able to support an active reactive power flow as shown in Fig. 4.

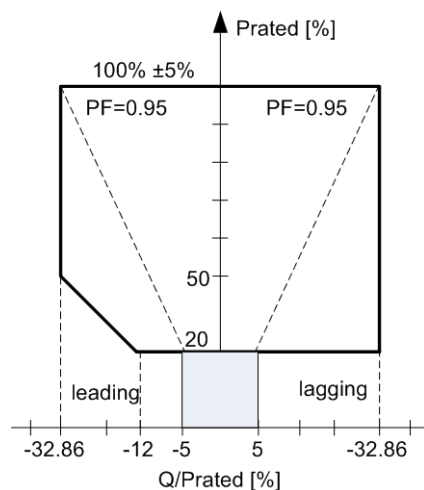

Fig. 4. Active/reactive power flow in the PCC for embedded generation in GB grid.

The reactive power output under steady state conditions should be fully available within the voltage range $\pm 5\%$ at 400 kV, 275 kV, and 132 kV and lower voltages except the distributed generation if embedded at 33 kV and below where the requirements shown in Fig. 5 are applied.

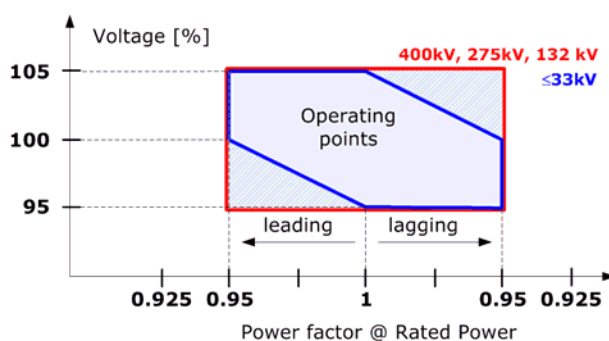

Fig. 5. Reactive power control characteristic.

Canada - Alberta Province

Reactive power control is according to Fig. 6.

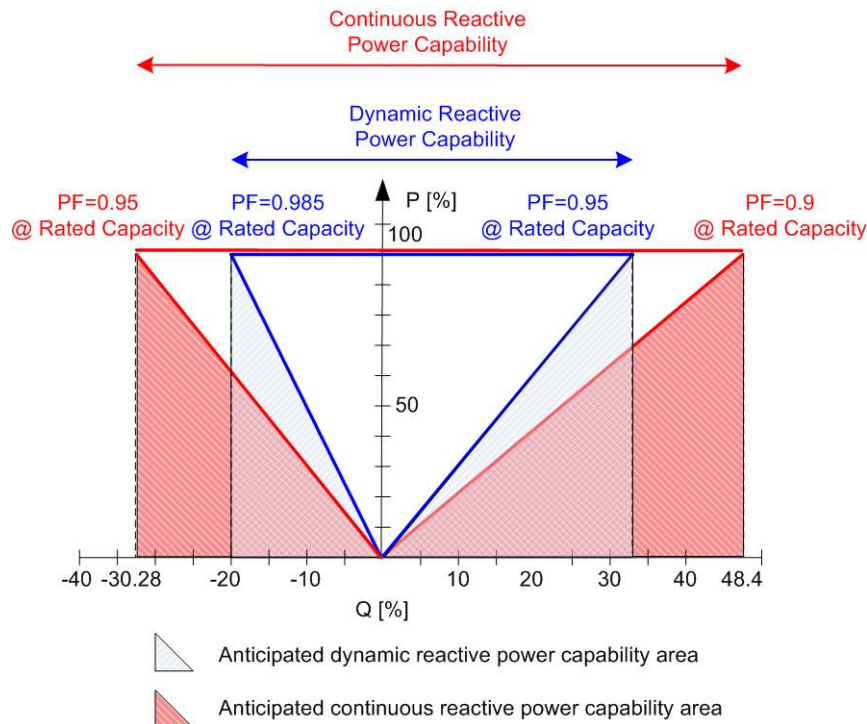

Fig. 6. Reactive power control range in Alberta/Canada [8].

Canada – Ontario Province

- asynchronous generators must have the same capabilities as synchronous generators
- at full MW output – a provision of 30 MVAR for every 90 MW or real power -> ca 0.95 power factor
- For WTs is required
 - dynamic reactive power capability or VAR compensation in PCC
 - VAR compensation

Canada – Quebec Province

Reactive power control is not mandatory, however a power factor of 0.95 leading/lagging is required for full scale power converter based WTs and DFIG WTs.

Impact

Benefits (and drawbacks/limitations) to power system

Increase value of wind power. Reduce the demand for other Reactive Power Compensation units in the system.

Dependence on other measures

Frequency and voltage control in connection with active power control.

LVRT requirements shall be considered beside normal operation demands.

HVDC connection removes grid control/support demands from the wind farm/turbines, here reactive power control/supply at the wind farm side of the HVDC connection will more be a matter of optimising system efficiency.

Environmental impact**Business issues*****Costs******Manufacturers******Patents*****Status*****Existing installations (examples if available)******Potential development******Research and development***

Title	Country	Grant	Year
Operation and control of large wind turbines and wind farms	Denmark	PSO Elkraft FU2102	2002

Bottlenecks**Other issues****References**

- [1]. EnergiNet – Grid connection of wind turbines to networks with voltages below 100 kV, Regulation TF 3.2.6, May 2004, p. 29;
- [2]. Energinet - Grid connection of wind turbines to networks with voltages above 100 kV, Regulation TF 3.2.5, December 2004, p. 25;
- [3]. ESB Networks – Distribution Code, version 1.4, February 2005;
- [4]. CER – Wind Farm Transmission Grid Code Provisions, July 2004;
- [5]. E.ON-Netz – Grid Code. High and extra high voltage, April 2006;
- [6]. VDN – Transmission Code 2003. Network and System Rules of the German Transmission System Operators, August 2003;
- [7]. National Grid Electricity Transmission plc – The grid code, Issue 3, Revision 17, September 2006;
- [8]. CanWEA - Canadian Grid Code for Wind Development Review and Recommendations, Document no. 11163/OR/01 B, 2005 Garrad Hassan Canada Inc.;

Contacts

Paul Bach Thøgersen, pbt@kk-electronic.dk

Florin Iov, fi@iet.aau.dk

Poul Sørensen, poul.e.soerensen@risoe.dk

Thomas Ackermann, thomas.ackermann@ieee.org

5.4.3 Wind Power – Low Voltage Ride-Through Capabilities

Technical description

Main issues

Title	Wind Power – LVRT Capabilities
Type of market	Regulation power and grid control
Generation or demand	Generation
Transmission or distribution	Transmission and Distribution
Scale	100% of future wind turbine power (3000 MW)
Supporting systems and procedures	Existing control systems
Main players	TSO, DSO and wind farm owners

Brief description

Currently, many national grid codes require fault ride-through capabilities for wind turbines/farms [1]-[18]. A summary of these requirements is given in Table 1. [19]. Voltage profiles are given specifying the depth of the voltage dip and the clearance time as well. However, in some of the grid codes the calculation of the voltage during all types of unsymmetrical faults is very well defined, e.g. Ireland, while others do not define clearly this procedure

Table 1. Summary of ride-through capability for wind turbines/farms in different national grid codes.

Country	Voltage Level	Fault ride-through capability				
		Fault duration	Voltage drop level	Recovery time	Voltage profile	Reactive current injection
Denmark	DS	100 msec	25%U _r	1 sec	2, 3-ph	no
	TS	100 msec	25%U _r	1 sec	1, 2, 3-ph	no
Ireland	DS/TS	625 msec	15%U _r	3 sec	1, 2, 3- ph	no
Germany	DS/TS	150 msec	0%U _r	1.5 sec	generic	Up to 100%
Great Britain	DS/TS	140 msec	15%U _r	1.2 sec	generic	no
Spain	TS	500 msec	20%U _r	1 sec	generic	Up to 100%
Italy	> 35 kV	500 msec	20%U _r	0.3 sec	generic	no
USA	TS	625 msec	15%U _r	2.3 sec	generic	no
Ontario	TS	625 msec	15%U _r	-	-	no
Quebec	TS	150 msec	0%U _r	0.18 sec	Positive-sequence	no

The voltage profile for ride-through capability can be summarized as shown in Figure 1. Ireland's grid code is very demanding in respect with the fault duration while Denmark has the lowest short circuit time duration with only 100 msec. However, Denmark's grid code requires that the wind turbine shall remain connected to the electrical network during successive faults. The German grid code requires that the

wind power installations must remain connected during voltage sags down to 0% from the rated voltage in the PCC for duration of 150 msec. Moreover, during the fault a reactive current injection up to 100% is required. Same requirement regarding the reactive current injection is present in the Spanish grid code.

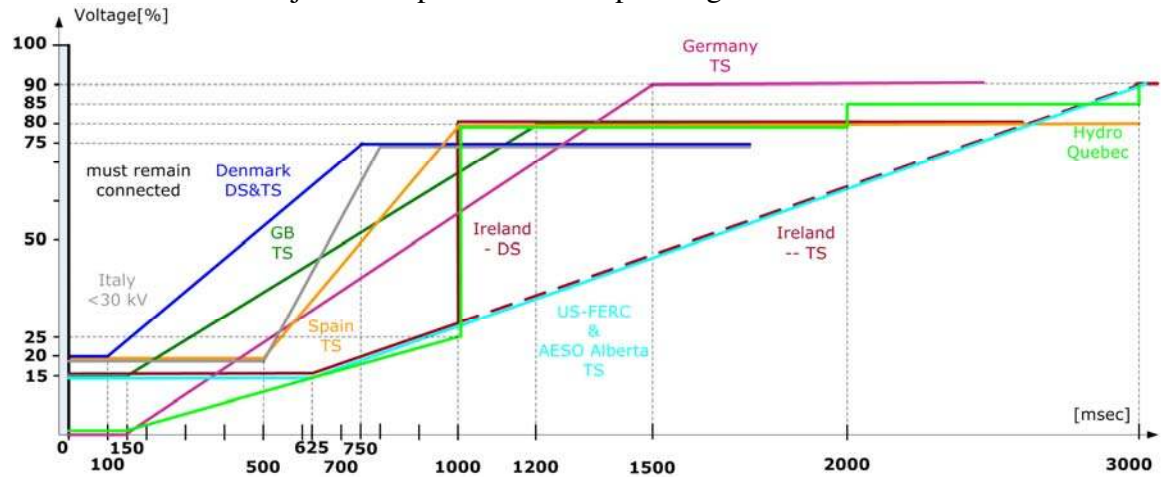

Figure 1

Impact

Benefits (and drawbacks/limitations) to power system

Increase value of wind power.

Reduce the need for spinning reserves

Dependence on other measures

HVDC connection removes the direct Ride Through demands from the wind farm/turbines, but the whole system (HVDC + Wind Farm combined) should still be able to handle Ride Through demands.

Environmental impact

Reduce the need for fuel consuming spinning reserves

Business issues

Costs

Manufacturers

Patents

Status

Existing installations (examples if available)

Today, all major wind turbine manufacturers provided LVRT

Potential development

Research and development

Bottlenecks

Other issues

References

- [1]. EnergiNet – Grid connection of wind turbines to networks with voltages below 100 kV, Regulation TF 3.2.6, May 2004, p. 29;
- [2]. Energinet - Grid connection of wind turbines to networks with voltages above 100 kV, Regulation TF 3.2.5, December 2004, p. 25;
- [3]. ESB Networks – Distribution Code, version 1.4, February 2005;
- [4]. CER – Wind Farm Transmission Grid Code Provisions, July 2004;
- [5]. E.ON-Netz – Grid Code. High and extra high voltage, April 2006;
- [6]. VDN – Transmission Code 2003. Network and System Rules of the German Transmission System Operators, August 2003;
- [7]. VDN – Distribution Code 2003. Rules on access to distribution networks, August 2003;
- [8]. National Grid Electricity Transmission plc – The grid code, Issue 3, Revision 17, September 2006;
- [9]. REE – Requisitos de respuesta frente a huecos de tensión de las instalaciones de producción de régimen especial, PO 12.3, November 2005;
- [10]. ENEL – DK 5400 - Criteri di allacciamento di clienti alla rete AT della distribuzione, October 2004;
- [11]. ENEL - - DK 5740 - Criteri di allacciamento di impianti di produzione alla rete MT di ENEL distribuzione, February 2005;
- [12]. TERNA - Codice di trasmissione, dispacciamento, sviluppo e sicurezza della rete, 2006;
- [13]. CEI 11/32, Appendice N.6 – Normativa impianti di produzione eolica, February 2006 (draft);
- [14]. *** - Going mainstream at the grid face. Examining grid codes for wind, Windpower Monthly, September 2005;
- [15]. FERC – Interconnection of Wind Energy, 18 CFR Part 35, Docket No. RM05-4-001; Order No. 661-A December 12, 2005;
- [16]. CanWEA - Canadian Grid Code for Wind Development Review and Recommendations, Document no. 11163/OR/01 B, 2005 Garrad Hassan Canada Inc.;
- [17]. Hydro-Québec TransÉnergie – Transmission Provider Technical Requirements for the connection of power plants to the Hydro-Québec Transmission System, March 2006;
- [18]. Alberta Electric System Operator – Wind Power Facility. Technical Requirements, Revision 0, November 2004;
- [19]. F. Iov, A.D. Hansen, P. Soerensen, N.A. Cutululis – Mapping of grid faults and grid codes, Risø-R-1617(EN) July 2007, 41 p., ISSN 0106-2840, ISBN 978-87-550-3622-2.

Contacts

Paul Bach Thøgersen, pbt@kk-electronic.dk

Florin Iov, fi@iet.aau.dk

Poul Sørensen, poul.e.soerensen@risoe.dk

Thomas Ackermann, thomas.ackermann@ieee.org

5.4.4 Wind Farm control - Grid Synchronization and Monitoring

Technical description

Main issues

Title	Wind Farm control: Grid Synchronization and Monitoring
Type of market	Regulation power and grid control
Generation or demand	Generation
Transmission or distribution	Transmission and distribution
Scale	
Supporting systems and procedures	Control systems
Main players	TSO/DSO and wind farm owners

Brief description

The increased penetration of DPGS connected to the electrical grid based on renewable sources necessitates better grid condition detection in order to meet standard specifications in terms of power quality and safety.

Grid-connected converter systems rely on accurate and fast detection of the phase angle, amplitude and frequency of the utility voltage to guarantee the correct generation of the reference signals. This is also required by the relevant grid codes which are country specific and can vary also in respect to the generation system (e.g. PV systems, wind turbines, fuel cell, etc). The grid codes may refer to different standards for distributed generation systems. These standards impose the operation conditions of the grid-connected converter systems in terms of grid voltage amplitude and frequency. The operational ranges for wind turbines connected to the Danish distribution system (voltages below 100 kV) are shown in Figure 1.

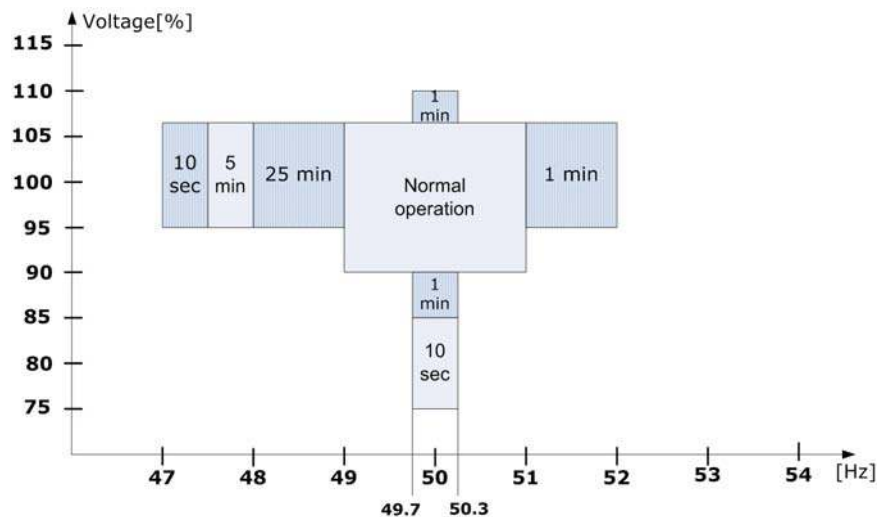

Figure 1. Operational range of wind turbines connected to the Danish distribution system [1].

However, these requirements can be very hard for some renewable sources e.g. PV as shown in Figure 2 [3] and [4]

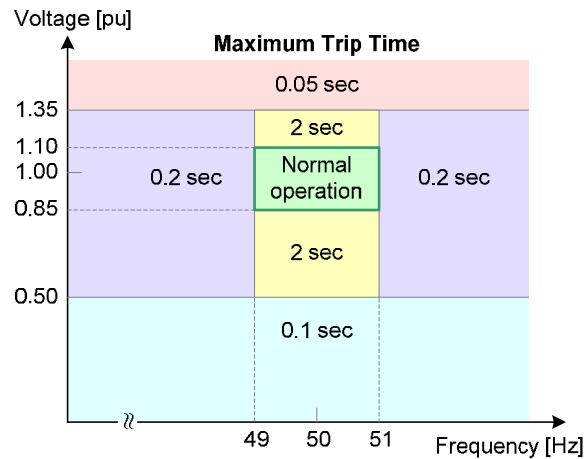

Figure 2. Maximum trip times for both voltage amplitude and frequency according to the standard IEC61727 [4].

As it can be noticed from Figure 2, the most restrictive requirement is when the maximum trip time is 0.05 seconds for a grid voltage amplitude excursion above 1.35 pu. An accurate and fast grid voltage monitoring algorithm is required in order to comply with these requirements.

The principle of the grid voltage monitoring which consists in obtaining the parameters of the grid voltage is shown in Figure 3 [3].

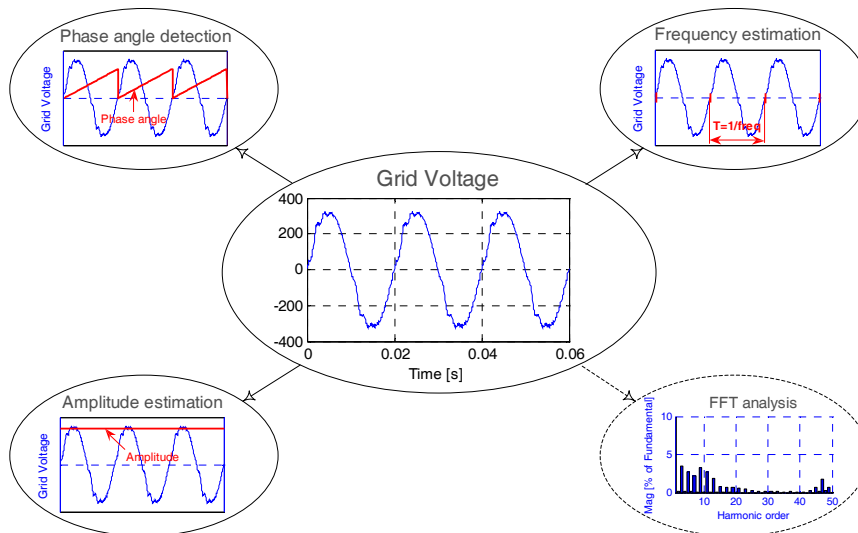

Figure 3. Grid voltage monitoring principle.

Different algorithms are used in order to monitor the grid voltage. In the technical literature numerous methods using different techniques are presented. These methods can be organized in three main categories:

- methods based on Zero-Crossing Detection (ZCD),
- methods based on Phase-Locked Loop (PLL)
- methods based on arctangent function (\tan^{-1}).

Each of these methods has advantages and drawbacks.

Recently, there has been an increasing interest in PLL techniques for grid-connected converter systems [3]. Usually, the PLL technique is mainly applied in communication technologies. Though, it has been proven that its application in the grid-connected converter systems was a success [3], [5] and [6].

Using the PLL, the grid voltage parameters such as amplitude and frequency, can be easily monitored.

Impact

Benefits (and drawbacks/limitations) to power system

Benefits

- Provides fast and accurate information about voltage amplitude and frequency.
- Accurate fault detection
- Provides information about the fault type if single phase PLL are used. Currently, the Distribution system is not monitored and few information exists

Drawback

- Voltage measurement transducers on each phase. However, these are already installed in power converter based systems connected to the electricity network.

Dependence on other measures

Grid detection and monitoring can have an important impact on all control measures:

- Fault ride-through capability – based on the fault type different strategies for control can be selected e.g. full reactive current injection, unity power factor, etc.
- Smooth transition from grid connected mode to island mode and back.
- Voltage control on island operation mode for unbalanced loads
- Black-start capability
- Control of converters for the HVDC-link

Environmental impact

Business issues

Costs

Manufacturers

Patents

Status

Existing installations (examples if available)

Potential development

Research and development

Bottlenecks

Other issues

References

- [1] EnergiNet – Grid connection of wind turbines to networks with voltages below 100 kV, Regulation TF 3.2.6, May 2004, pp. 29
- [2] Energinet - Grid connection of wind turbines to networks with voltages above 100 kV, Regulation TF 3.2.5, December 2004, pp. 25.
- [3] F. Iov, M. Ciobotaru, D. Sera, R. Teodorescu, F. Blaabjerg - *Power Electronics and Control of Renewable Energy Systems*, keynote paper in Proc. of The 7th International Conference on Power Electronics and Drives Systems, PEDS 07, 27-30 november 2007, Bangkok, Thailand, 23 p. ISBN 1-4244-0645-5
- [4] "Characteristics of the utility interface for photovoltaic (PV) systems," IEC 61727-2002, 2002
- [5] J. W. Choi, Y.K. Kim, and H.G. Kim, "Digital PLL control for single-phase photovoltaic system", IEE Trans. on Electric Power Applications, 2006, Vol. 153, pp. 40-46.
- [6] S.K. Chung, "A phase tracking system for three phase utility interface inverters", IEEE Trans. on Power Electronics, 2000, Vol. 15, pp. 431-438.

Contacts

Paul Bach Thøgersen, pbt@kk-electronic.dk

Florin Iov, fi@iet.aau.dk

Poul Sørensen, poul.e.soerensen@risoe.dk

Thomas Ackermann, thomas.ackermann@ieee.org

5.4.5 Wind Farm control - Virtual inertia

Technical description

Main issues

Title	Wind Farm control - Virtual inertia
Type of market	Regulation power
Generation or demand	Generation/demand
Transmission or distribution	Transmission
Scale	100% of future wind turbine power (3000 MW)
Supporting systems and procedures	Modified control systems
Main players	TSO and wind farm owners

Brief description

The traditional plant is expected to resist the change in frequency, initially because of its inertia and at a later stage as a result of free governor action. The inertial response is approximately in the 0-3sec period after a system disturbance. There is no need for a control system, and the response naturally obeys a df/dt function. However, in the variable speed type of wind turbines this is no longer true and they do not have this sort of “rapid frequency response” capability [1]. Hence, there is a need to provide control strategy to emulate this “virtual inertia” effect. However, it still remains to be examined whether this control action would be at the wind turbine level or a wind farm controller could provide it (by controlling individual wind turbine).

In [6] some studies regarding the influence of the inertia control implemented for DFIG based wind turbines are presented. A block diagram of this inertia control is shown in Figure 1 and the simulation results in Figure 2.

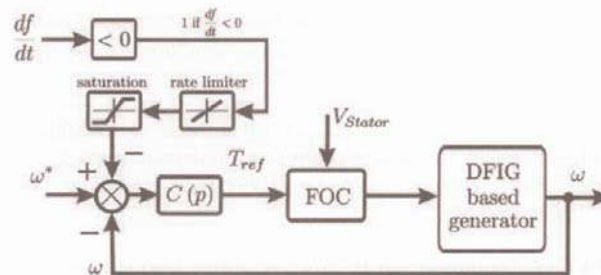

Figure 1. Schematic of the inertia control implemented in a DFIG wind turbine [6].

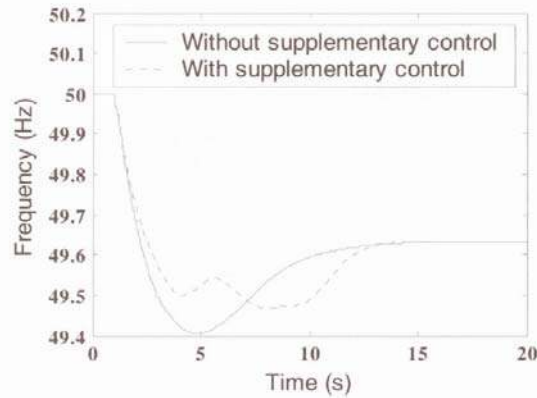

Figure 2. Comparison of frequency traces following loss of 400 MW of generation for power converter based DFIGs with and without virtual inertia control [6].

Impact

Benefits (and drawbacks/limitations) to power system

Advantages

- Contributes to the “inertial response” and there by reduce the rate of change of frequency and even maximum frequency dip.
- Some of the energy stored in the rotating mass of the wind turbine can be used for dynamic frequency support

Drawbacks:

- Additional stress on the wind turbine mechanical drive train (yet to be investigated).
- Reduced wind turbine rotor speeds can cause the wind turbine to stall and become unstable

Dependence on other measures

Could benefit the power system protection and may limit false operation of the relays (Rate of Change of frequency relay).

Could be integrated with the other Active Power Regulating Functions into an ‘optimised package’ for improved dynamic frequency support.

Environmental impact

Reduce the need for fuel consuming spinning reserves

Business issues

Costs

Manufacturers

Patents

Status

Existing installations (examples if available)

Potential development

Research and development

Bottlenecks

Other issues

References

- [1] L. Holdsworth, J. B. Ekanayake, N. Jenkins, “Power System Frequency Response from Fixed Speed and Doubly Fed Induction Generator based Wind Turbines”, *Wind Energy*, 2004, 7, pp. 21–35
- [2] G. Ramtharan, J.B. Ekanayake and N. Jenkins, “Frequency support from doubly fed induction generator wind turbines”, *IET Renew. Power Gener.*, 2007, 1, (1), pp. 3–9
- [3] Johan M., Sjoerd W., Wil L., and Ferreira J., “Wind turbines emulating inertia and supporting primary frequency control”, *IEEE Trans. Power Syst.*, 2006, 21, (1), pp. 433–434
- [4] Mullane A., and O’Malley M, “The inertial response of induction-machine-based wind turbines”, *IEEE Trans. Power Syst.*, 2005, 20, (3), pp. 1496–1503
- [5] Lalor G., Mullane A., and O’Malley M., “Frequency control and wind turbine technologies”, *IEEE Trans. Power Syst.*, 2005, 20, (4), pp. 1905–1913
- [6] M. Mullane, A.; O’Malley, **Modifying the Inertial Response of Power-Converter Based Wind Turbine Generators** *Power Electronics, Machines and Drives*, 2006. The 3rd IET International Conference on Mar. 2006 Page(s):121 – 126
- [7] Sørensen, P.; Hansen, A.D.; Iov, F.; Blaabjerg, F.; Donovan, M.H., *Wind farm models and control strategies*. Risø-R-1464(EN) (2005) 63 p.

Contacts

Paul Bach Thøgersen, pbt@kk-electronic.dk

Florin Iov, fi@iet.aau.dk

Poul Sørensen, poul.e.soerensen@risoe.dk

Thomas Ackermann, thomas.ackermann@ieee.org

5.4.6 Wind Turbines Optimal Production Control

Technical description

Main issues

Title	Wind Turbines optimal production control
Type of market	Variable energy price demand
Generation or demand	Generation
Transmission or distribution	Transmission and Distribution
Supporting systems and procedures	Existing control systems
Main players	wind farm owners

Brief description

The idea is to control the wind turbine power according to an optimisation (cost/benefit) function. This function should calculate an optimal power level based on actual values of energy and power payment and cost of operation. These calculations can include the following aspects:

- Life-time consumption
- Operational costs
- Electricity price on the spot market
- Regulating Power (active and reactive) price on the spot market

Impact

Benefits (and drawbacks/limitations) to power system

Advantages:

- Decrease power production as function of energy price
- Optimise operational life of wind turbines based on a cost/benefit function
- Increased headroom for Active and Reactive Power Control functions during low price periods.

Drawbacks:

- More difficult to predict wind power production available, as it will be a function of the price of energy (and perhaps also regulating power)

Dependence on other measures

Environmental impact

- Decreased wind energy production, possibly increased CO₂ emissions in neighbour countries due to lower export during low price periods. On the other hand, increased headroom for Active and Reactive Power Control functions during low price periods may reduce the need for fuel consuming spinning reserves.

Business issues

Costs

Issue	Value	Ref
Specific investment (M€/MW)	Low	guess

Manufacturers

Patents

Status

Existing installations (examples if available)

Potential development

Research and development

Title	Country	Grant	Year	Ref
Operation and control of large wind turbines and wind farms	Denmark	PSO Elkraft FU2102	2002	[1]

Bottlenecks

Other issues

References

Sørensen, P.; Hansen, A.D.; Thomsen, K.; Buhl, T.; Morthorst, P.E.; Nielsen, L.H.; Iov, F.; Blaabjerg, F.; Nielsen, H.Aa.; Madsen, H.; Donovan, M.H., Operation and control of large wind turbines and wind farms. Final report. Risø-R-1532(EN) (2005) 44 p.

Contacts

Paul Bach Thøgersen, pbt@kk-electronic.dk

Florin Iov, fi@iet.aau.dk

Poul Sørensen, poul.e.soerensen@risoe.dk

Thomas Ackermann, thomas.ackermann@ieee.org

5.4.7 Wind Farm control - Overload capability

Technical description

Main issues

Title	Wind Farm control Overload capability
Type of market	Regulation power
Generation or demand	Generation
Transmission or distribution	Transmission and Distribution
Supporting systems and procedures	Existing control systems
Main players	TSO and wind farm owners

Brief description

At wind speeds higher than the rated values, wind turbines can produce higher than rated power, if the design allows for it. There will be a trade of between use of lifetime and value of production. Overload capability for future wind turbines will make it possible to operate in delta-control (with a defined up-regulating capacity) at a higher power level. For example, instead of operating at 80% rated power with a 20% reserved up-regulating capacity, this level could be shifted to 90%, if the wind turbine could operate with 110% load.

Impact

Benefits (and drawbacks/limitations) to power system

Increase value of wind power.

Increase production during delta-control and/or increase up-regulating capacity

Drawbacks:

Extra consumption of lifetime in overload operation.

Dependence on other measures

If other (expensive) regulating power sources can be shut down, the value of the wind power/energy during high wind conditions will be increased.

A number of functions must be available in order to gain full benefit from Overload Capability, such as Active Power regulating, Reactive power control and Optimal Production Control.

Environmental impact

Reduce the need for fuel consuming spinning reserves.

Business issues

Costs

Issue	Value	Ref
Specific investment (M€/MW)	0.2	guess
Availability (%)	above rated wind speed, 1-10%	

Specific investment (M€/MW) = 0.2 is a roughly estimated value based on a wind turbine cost of around 1 M€/MW and a marginal cost of a 10% high wind overload capability equal to 2%.

Manufacturers

Patents

Status

Existing installations (examples if available)

Potential development

Research and development

Bottlenecks

Other issues

References

Contacts

Paul Bach Thøgersen, pbt@kk-electronic.dk

Florin Iov, fi@iet.aau.dk

Poul Sørensen, poul.e.soerensen@risoe.dk

Thomas Ackermann, thomas.ackermann@ieee.org

5.4.8 Wind Farm control - Black start support

Technical description

Main issues

Title	Wind Farm control Black start support
Type of market	Back up power and control in future Transmission and Distribution grids
Generation or demand	Generation
Transmission or distribution	Transmission and Distribution
Scale	100% of future wind turbine power (3000 MW)
Supporting systems and procedures	Existing control systems, perhaps upgraded
Main players	TSO, DSO and wind farm owners

Brief description

In a future grid setup with much more wind power, control functions are needed, so that the Wind Farms are able to support the grid control together with other available generators (CHP etc.). The Wind Farms may constitute a major part of the generator power available on the actual TS/DS grid.

The wind farm control functions to be investigated could include black start support, which could be at TS as well as DS level.

This function must be coordinated with the overall generator control in the grid control system, perhaps as a part of Virtual Power Plant control system [2].

Command, Control and Communication philosophies (Central versus de-central control, high performance communication etc.) should be considered.

Impact

Benefits (and drawbacks/limitations) to power system

Advantages

- Increase value of wind power.
- Increase robustness/reliability/up-time (if it is possible to black start and operate a grid in island operation)

Drawbacks:

- Possibly a more complex and costly control and communication system
- More complex and costly wind turbines.

Dependence on other measures

Island operation support functionality should be available.

Micro-grid structure/organisation with some kind of Virtual power plant (or similar) control setup may be needed, so that the new wind turbine/wind farm control functions can be utilized, at least at DS level.

For Wind Farms with HVDC connection there are several possibilities. The Wind Farm could continue operation (together with the Wind Farm side HVDC converter) during the black-out of the grid, and therefore be able to deliver power through the Black Start operation. If there

is a total black-out including the HVDC and the Wind Farm, then the system could be restarted either from the HVDC side or the Wind Farm side (both would require Black Start capability).

Environmental impact

Low, mainly based on smarter control of existing equipment

Business issues

Costs

Issue	Value	Ref
Availability (%)	Medium and High wind	

Manufacturers

Patents

Status

Existing installations (examples if available)

Potential development

Research and development

Title	Country	Grant	Year
Operation and control of large wind turbines and wind farms	Denmark	PSO Elkraft FU2102	2002

Bottlenecks

Other issues

References

[1] Hansen, A.D.; Sørensen, P.; Iov, F.; Blaabjerg, F., *Power control of a wind farm with active stall wind turbines and AC grid connection*, EWEC 2006, Athene, Greece, p. 6, available on-line at <http://ewec2006proceedings.info/>

[2] <http://www.fenix-project.org/>

Contacts

Paul Bach Thøgersen, pbt@kk-electronic.dk

Florin Iov, fi@iet.aau.dk

Poul Sørensen, poul.e.soerensen@risoe.dk

Thomas Ackermann, thomas.ackermann@ieee.org

5.4.9 Wind Farm control - Island operation support

Technical description

Main issues

Title	Wind Farm control island operation support
Type of market	Regulation power and control in future transmission system (TS) and distribution system (DS) grids
Generation or demand	Generation
Transmission or distribution	Transmission and Distribution
Supporting systems and procedures	Existing control systems, perhaps upgraded
Main players	TSO, DSO and wind farm owners

Brief description

In a future grid setup with much more wind power, control functions are needed, so that the Wind Farms are able to support the grid control together with other available generators (CHP etc.). The Wind Farms may constitute a major part of the generator power available on the actual TS/DS grid.

The wind farm control functions to be investigated could include island operation support, which could be at TS as well as DS level.

This function must be coordinated with the overall generator control in the grid control system, perhaps as a part of Virtual Power Plant control system [2].

Command, Control and Communication philosophies (Central versus de-central control, high performance communication etc.) should be considered.

In this case some of the concepts applied in Mini/Micro grids can be used.

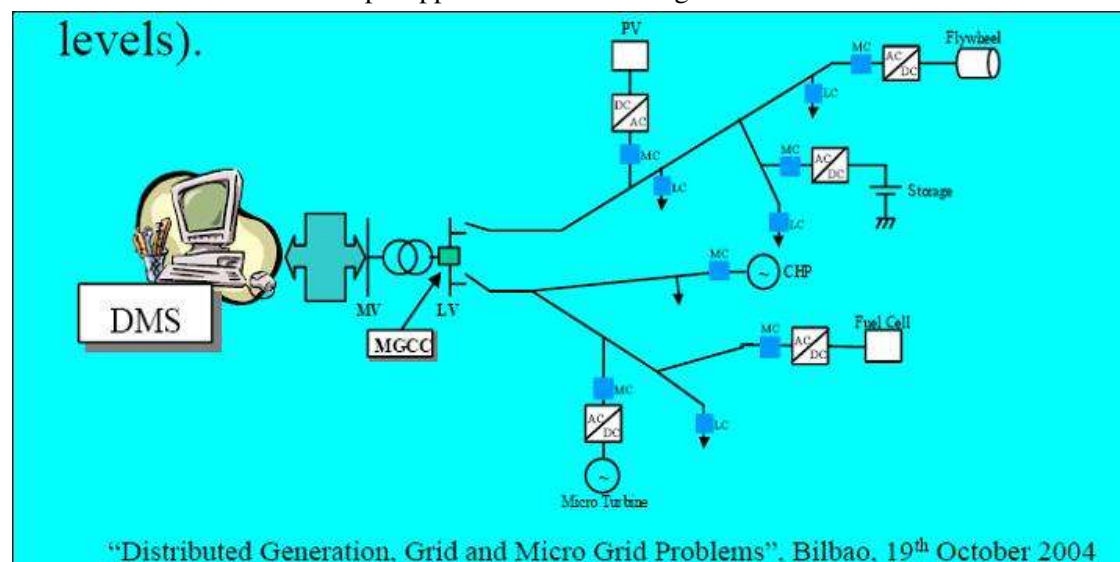

Figure 1. Structure of a microgrid with different renewable sources (Source [3])

This architecture requires different control levels with different control objectives as:

- MicroGrid Central Controller (MGCC)
 - short term forecasting
 - promotes technical and economical operation

- provides set points to LC and MC;
- interface with loads and micro sources and Distribution Management System;
- load shedding
- Microsource Controller (MC)
 - Maximum Power Point Tracking
 - Active power / frequency control
 - Reactive power / voltage control
- Load Controller (LC)

The MicroGrid Central Controller (MGCC) is responsible with mainly two mode of operation:

- Normal operation or grid connected operation
 - interface with loads and micro sources and Distribution Management System
 - short term forecasting (sources and loads)
 - provides set points to LC and MC (P/Q control);
 - promotes technical and economical operation
 - on-line security functions
 - analysis of operation points considering reliability aspects
 - steady state security
 - dynamic criteria
 - demand side management functions
 - interruptible loads
 - economic scheduling -> might be considered
 - participation in el-spot market
- Island operation and black-start
 - maintain operation using local sources
 - grid reconnection and synchronization during/after black-outs
 - switch to voltage/frequency control and load shedding

Droop characteristics are used for both frequency and voltage control in island operation.

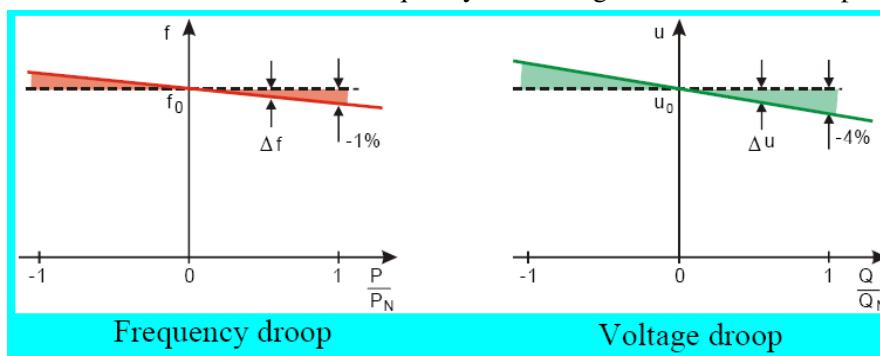

Figure 2. Droop control characteristics for frequency and voltage (Source [3]).

The following advantages of this droop control must be mentioned:

- allows parallel operation of multiple power converters
- no communication between sources is needed
- increased overload capability of the system
- it can be combined with any type of generator

However this control requires fast and accurate measurement of voltage and current as well as advanced control algorithms (DSP).

Impact

Benefits (and drawbacks/limitations) to power system

Advantages

- Increase value of wind power.
- Decrease need for standby capacity (spinning reserves)
- Increase robustness/reliability/up-time

Drawbacks:

- Possibly a more complex and costly control and communication system
- More complex and costly wind turbines.

Dependence on other measures

Micro-grid structure/organisation may be needed, so that the new wind turbine/wind farm control functions can be utilized, at least at DS level.

The Wind Farms/Turbines should have many of the functions described in Active Power Regulating, Reactive Power Control, Grid synchronization and monitoring and perhaps even Black Start Support capability.

Environmental impact

Decrease need for fuel consuming spinning reserves

Business issues

Costs

Issue	Value	Ref
Availability (%)	Medium and High wind	

Manufacturers

Patents

Status

Existing installations (examples if available)

Potential development

Research and development

Bottlenecks

Other issues

References

- [1] Hansen, A.D.; Sørensen, P.; Iov, F.; Blaabjerg, F., *Power control of a wind farm with active stall wind turbines and AC grid connection*, EWEC 2006, Athene, Greece, p. 6, available on-line at <http://ewec2006proceedings.info/>
- [2] <http://www.fenix-project.org/>
- [3] Nikos Hatziaargyriou “Overview of MicroGrids, Problems and Solutions” , Distributed Generation, Grid and MicroGrids problems, Bilbao, Oct 2004

Contacts

Paul Bach Thøgersen, pbt@kk-electronic.dk

Florin Iov, fi@iet.aau.dk

Poul Sørensen, poul.e.soerensen@risoe.dk

Thomas Ackermann, thomas.ackermann@ieee.org

5.4. 10 Wind Farm control HVDC-VSC connection

Technical description

Main issues

Title	Wind Farm control HVDC-VSC connection
Type of market	TS connected generator – energy, regulating power
Generation or demand	Generation
Transmission or distribution	Transmission
Scale	3 offshore parks (3 x 200 MW at Horn Rev) (Nysted Havmøllepark 165MW) [1], [2]
Supporting systems and procedures	Existing grid codes
Main players	TSO and wind farm owners

Brief description

Connection of big wind farms to the 400 kV system through an HVDC-VSC link is considered due to promising technical and economical benefits, which might be further strengthened by future demands for cabling of the HV transmission grid.

It must be considered, that this combination (HVDC-VSC + Wind Farm) is new, and that very limited operational experience exists (Tjæreborg tests with old turbines).

The Tjæreborg wind farm consists of 4 different type of wind turbine with different nominal powers [3], [4]. Two of these turbines are pitch regulated while the other two are stall controlled. The rated power of the wind farm is 6.5 MW while until recently an HVDC system with 8 MVA rated power was installed

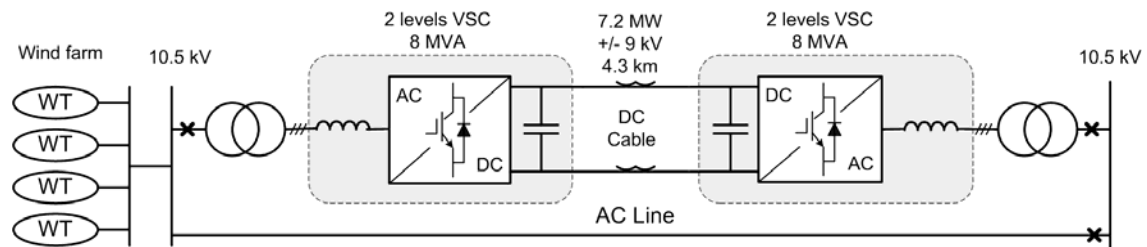

Figure 1. Tjæreborg system.

The DC transmission system was in parallel with an AC line and it has a length of 4.3 km. The voltage and frequency in the wind farm can be varied continuously and independently of the transmission grid [3], [4] using this DC link. In isolated operation the frequency can vary between 30 and 65 Hz [3].

According with [3] the control concept was implemented and tested in EMTDC program under different conditions and it has been found a “fairly good agreement between simulation and commissioning tests”. However, the frequency control of the wind farm was an exception. In simulation the dynamic frequency control worked fine [3]. During the commissioning test the frequency was varied between 47 and 51 Hz. Outside this range the wind turbines are tripped by their protections [3]. In [3] is mentioned that a reason for different result in simulation compared with the commissioning tests might be the difficulties in simulating correctly the dynamics of the wind farm.

The first large scale project, using a HVDC VSC in combination with an offshore wind farm, is the 400 MW NORD E.ON 1 (Borkum 2), to be built in 2009 (<http://www.abb.com/cawp/gad02181/306c726f332f36d3c1257353003b91f0.aspx>).

This transmission brings power from the offshore wind farm 130 km from the German North Sea coast to a substation 75 km inland by submarine and underground cables.

HVDC VSC technology is a proven technology for power transmission, but the combination with wind power is new, so fast and coordinated control of the wind farm and the HVDC-link will be a challenge, especially during grid faults with deep voltage sags, since a basic HVDC-VSC system has virtually no DC-link energy storage (5 ms). A 'brake chopper' with a dump load resistor in the DC link could be an alternative (hardware) option to the fast control.

A typical HVDC link topology uses a full scale HVDC system rated at the wind farm rated power as shown in Figure 2. The low or medium AC voltage at the wind farm is converted into a high dc voltage on the transmission side and the DC power is transferred to the on-shore system where the DC voltage is converted back into AC voltage.

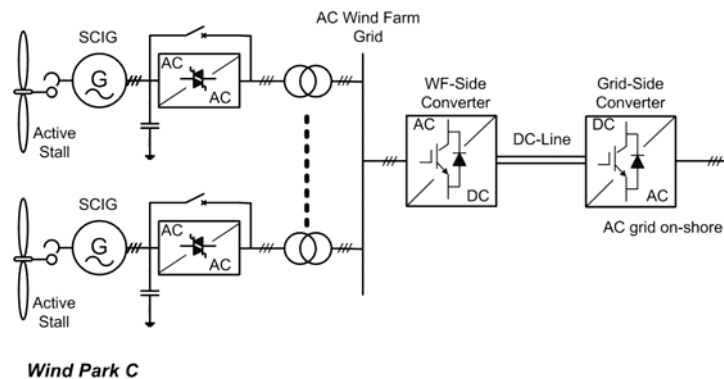

Figure 2. Wind farm with an HVDC grid connection [6].

Impact

Benefits (and drawbacks/limitations) to power system

Advantages:

- Increase regulation capabilities with grid support functions (dynamic reactive power-control, voltage and frequency support,
- low harmonic content for both voltage and current in the Point of Common Coupling (PCC).

Drawbacks:

- New technology for wind farm connection, no existing experience with full scale control and/or interaction between HVDC and wind farm/turbine control systems.
- Grid code performance (fault ride through) with HVDC-VSC and a Wind Farm as a complete system is not established technology (this functionality must be developed in order to fulfil basic requirements).
-

Dependence on other measures

Wind farm and wind turbine control systems have to be adapted for HVDC, and the HVDC control must also be adapted for/coordinated with the wind farm/turbine control, so basically all functions, described in Active Power Regulating, Virtual Inertia, Reactive Power Control, Grid synchronization and monitoring, Black Start Support, Island Operation Support and LVRT, have to be redesigned and supported (or taken care of) by the HVDC control system.

Since a basic HVDC-VSC system has a very low energy storage capacity in the DC-link, care must be taken when designing functions which needs fast power control. This requires tight dynamic control of the power balance between the HVDC system and the connected Wind Farm.

Environmental impact

Reduce the need for fuel consuming spinning reserves

Reduce the need for alternative grid supporting units

Replace overhead lines

There could be some noise from unshielded reactors due to the switching frequency in the audio band (1-4kHz).

Cables are placed in corridors without plantation.

Business issues

Costs

Manufacturers

Patents

Status

Existing installations (examples if available)

No existing installations with modern wind turbines.

The first power plant size (offshore) wind park with HVDC link will be Borkum 2, which is planned for operation in 2009, see link below.

[http://library.abb.com/GLOBAL/SCOT/scot221.nsf/VerityDisplay/8ED909FA2F75084AC125736A0039A67F/\\$File/POW-0050%20Rev3%20Borkum.pdf](http://library.abb.com/GLOBAL/SCOT/scot221.nsf/VerityDisplay/8ED909FA2F75084AC125736A0039A67F/$File/POW-0050%20Rev3%20Borkum.pdf)

Other existing installations are not used for connecting wind power (see Table)

Place	Time	Capacity	Function	Manufacturer	Ref
Borkum 2	2009	400 MW	HVDC connected wind farm	Bard wind turbines, ABB HVDC Light	
Gotland		50 MW ± 80 kV 70 km underground	Wind power Voltage support Stabilize AC lines	ABB HVDC Light	[5]
DirectLink		3x60 MW ±80 kV 65 km underground	Asynchronous Tie Weak systems Environmental Permitting	ABB HVDC Light	[5]
Murray Link		200 MW	Asynchronous Tie	ABB HVDC Light	[5]

		±150 kV 180 km underground	Weak systems Environmental Permitting		
--	--	----------------------------------	---	--	--

Potential development

Grid code performance (fault ride through) with HVDC-VSC and Wind Farm as a complete system (must be done to fulfil basic requirements).

Grid support functions in HVDC grid inverter

Integration of electrical energy storage in the DC link.

More simple wind turbines with DC-interface (voltage levels, converters)

Research and development

Bottlenecks

Price and limited number of producers.

Other issues

References

- [1] <http://www.abb.com/hvdc>
- [2] http://www.owen.eru.rl.ac.uk/workshop_4/pdfs/siemens.htm
- [3] A-K Skytt, P.Holmberg, L-E Juhlin – *HVDC Light for connection of wind farms*, Proceed. on 2nd International WorkShop on Transmission Networks for Offshore Wind Farms, Royal Institute of Technology Stockholm, Sweden, March 29-30, 2001;
- [4] K.H. Søbriink, P.L. Sørensen, et all – *DC Feeder for connection of a wind farm*, Proceed. On Cigre Symposium, Kuala Lumpur, Malaysia, September 1999
- [5] M.P. Bahrman, J.G. Johansson, B.A. Nielsen – *Voltage source converter transmission technologies – the right fit for the application*, IEEE Proceed. on Power Eng. Soc. General Meeting, 2003, vol.3, pp.1840-1847;
- [6] F. Iov, F. Blaabjerg - *UNIFLEX-PM. Advanced power converters for universal and flexible power management in future electricity network – Converter applications in future European electricity network*. Deliverable D2.1, EC Contract no. 019794(SES6), February 2007, p. 171, (available www.eee.nott.ac.uk/uniflex/Deliverables.htm)

Contacts

Paul Bach Thøgersen, pbt@kk-electronic.dk

Florin Iov, fi@iet.aau.dk

Poul Sørensen, poul.e.soerensen@risoe.dk

Thomas Ackermann, thomas.ackermann@ieee.org

5.5.1 Point Forecasting of Wind Generation

Technical description

Brief technology description

Research developments on the forecasting of wind power generation started 15-20 years ago. Since then, multiple methodologies have been developed. Commercial tools are now available, distributed and maintained by a certain number of companies (or research institutes) in Europe. Forecasting is still an important (and very active) research field, being the main point of focus of several European research projects. Forecasts of wind power may be used for different purposes, depending on the time-scale considered. From seconds to minutes, they are used for control purposes. From hours to few days ahead, forecasts are a basis for defining optimal energy management or trading strategies. When forecasts are for horizons further than few days ahead, they may serve for instance for planning maintenance operation at offshore locations. More information on wind power forecasting can be found in Wikipedia [1], an overview of the main methodologies is available in [2], and a state of the art on research developments (up to 2003) is available in [3].

Technical/Implementation issues

Forecasting of wind generation can be implemented in the form of software installed at the client, or provided as a service by some forecast companies. In both cases, forecasting methods requires as input static and dynamic information for the site considered (a wind farm, a group of wind farm, or a region). Static information includes:

- Geographical coordinates
- Description of the wind farm layout (or spreading of wind turbines/farms if considering a region)
- Topography/orography/roughness in the vicinity of the wind farm (generally in the form of maps)

Note that such static information is mandatory for the so-called ‘physical’ forecasting methodologies, while they are optional for the so-called ‘statistical’ forecasting methodologies. In parallel, dynamic information includes:

- Meteorological forecasts of relevant meteorological variables (wind speed and directions, plus possibly humidity, temperature and pressure)
- Availability of the turbines
- Online power measurements (SCADA data, optional)
- Online meteorological measurements (SCADA data, optional)

Regarding dynamic information, the relevance of each of them depends on the intended application, and required level of accuracy for the very short-term (up to 6-8 hours ahead) and short-term (further than 6-8 hour ahead) look-ahead times. Forecasts of meteorological variables are mandatory for having a satisfactory level of performance for horizons further than 6-8 hour ahead, while online measurements permit to increase the level of accuracy for the very-short-term. Finally, availability of turbines is crucial for scaling the predictions to the level of available nominal capacity.

Safety issues

There are no specific safety issues.

Impact

Benefits (and drawbacks/limitations) to power system

Wind power being a variable source of energy, whose output is imposed by meteorological conditions and not by human control, forecasts are paramount in order to optimally plan the operation of the power system in view of this production. The more accurate wind power predictions are, the higher the benefits resulting from forecast-based decisions are. Indeed, the limitation of wind power predictions is their level of accuracy. While the various actors of a power system are used to levels of accuracy of 2-5% for day-ahead demand (load) forecasts, the level of accuracy of day-ahead wind power forecasts may vary between 4 and 25% of installed capacity. Such level of accuracy may depend on the size of the wind farm (or region) considered, on the type of the terrain, the forecasting method employed, etc. Methods for evaluation of wind power forecasts are described in [4], along with a discussion on expected level of performance, while the influence of some wind farm characteristics on the level of accuracy of wind power predictions is given in [5].

Dependence on other measures

Owing to this limited and variable level of forecast accuracy, it has proven paramount to associate wind power predictions with information on their situation-dependent level of uncertainty. The present measure on point forecasting of short-term (up to 48-72 hour ahead) wind power generation is therefore tightly related to that corresponding to estimation (and optimal communication) of the uncertainty of such forecasts.

In addition, since wind power forecasts serve as a basis for making bids on the Nord Pool electricity market, several studies now start to show what is the influence of wind power predictions on the electricity prices (spot, but mainly regulation ones), see e.g. [6]. As a consequence, the present measure on short-term wind power forecasting is tightly related to some of the market measures. Evolution of the electricity market in Denmark should account for the fact that wind power producers make their bids from forecasts which are not completely accurate.

Finally, it is important to understand the link between demand (load) and wind power production. Indeed, if the daily patterns for load and wind were fully correlated, this could make the management of the power system significantly easier. Hence, measure related to demand (load) forecasting, or demand-side management, should relate to the present measure on short-term forecasting of wind power generation.

Environmental issues

There are no particular environmental issues.

Business issues

Forecasting of wind generation is now a mature research field, for which R&D efforts are carried out both at research institutes and by commercial forecast providers. Prediction services or software are not only provided as output of research collaborations, but also as fully commercial products. In Denmark, some companies such as ENFOR A/S have been providing forecasts as a commercial software/service since 2006, while such software/service started to be offered few years earlier in Germany, Spain or the United States.

Forecast providers

In Denmark, the companies providing forecasting of wind generation as a service, or as software are:

- ENFOR A/S
- Vejr2 A/S
- WEPROG A/S

Note that a large number of other European companies provide similar services or software, and may be present on the Danish market in the future.

Status

Existing installations (examples if available)

Current users of wind power forecasts in Denmark (thus being clients of commercial forecast providers) include:

- Energinet.dk
- Vattenfall Danmark
- DONG Energy Generation
- Etc.

Most of these forecast users have a long experience with the use of wind power predictions, gained through collaborations with research institutes through Danish and European projects.

Research and Development

Research and development is very active in the field of wind power forecasting, with focus on various ways of improving the value of wind power predictions for their users. This includes for instance combination of forecasts, optimal selection of input information to forecasting models, regime-switching approaches permitting to account for extreme events, etc. A list of recent and current relevant research projects at the Danish and EU level is given below.

Projects

Title	Country	Grant	Year
Wind power ensemble forecasting	Denmark	PSO 2101	2002-2005
Intelligent wind power prediction systems	Denmark	PSO 4101	2004-2007
Improved wind power prediction	Denmark	PSO 5766	2004-2007
High Resolution Ensembles at Horns Rev	Denmark	PSO 6387	2006-2009
Anemos	EU	FP5	2002-2006
Anemos.plus	EU	FP6	2008-??
SafeWind	EU	FP7	2008-??

An overview of the major ongoing research projects (and coordination actions) at the European level are briefly described and discussed in [7]. Finally, the European Wind Energy Association has set up a technology platform, in which a group of forecasting experts focuses on defining a research agenda in order to reach a breakthrough in development of wind power forecasting technology [8].

Bottlenecks

The bottlenecks related to wind power forecasting are:

- the accuracy of predictions (especially timing of ramps), the improvement of which is a crucial challenge for the forecasting community in the short to medium-term
- the providing of a valuable information related to the situation-dependent uncertainty of wind power forecasts (cf. measure on uncertainty of wind power predictions)
- the optimal use of point forecasts, which involves development of methods and training of forecast users

Other issues

There are no specific other issues.

References

- [1] http://en.wikipedia.org/wiki/Wind_Power_Forecasting
- [2] L. Landberg, G. Giebel, H.Aa. Nielsen, T.S. Nielsen, H. Madsen (2003). Short-term prediction - An overview. *Wind Energy* 6(3): 273-280
- [3] G. Giebel, G. Kariniotakis, R. Brownsword (2003). State of the art on short-term wind power prediction. Technical Report, Anemos Project Deliverable Report D1.1 [Online: <http://anemos.cma.fr>]
- [4] H. Madsen, P. Pinson, G. Kariniotakis, H.Aa. Nielsen, T.S. Nielsen (2005). Standardizing the performance evaluation of short term wind power prediction models. *Wind Engineering* 29(5): 475–489
- [5] G. Kariniotakis et al. (2004). What performance can be expected by wind power prediction models depending on site characteristics? In: Proc. EWEC 2004, ‘European Wind Energy Conference’, London, United Kingdom
- [6] T. Jónsson, H. Madsen (2007). The effect of wind power on electricity prices in Denmark. Technical Report, Technical University of Denmark, Informatics and Mathematical Modelling, 2007
- [7] G. Giebel, P. Meibom, P. Pinson, G. Kariniotakis (2007). Towards smart integration of wind generation. In: Proc. Nordic Wind Power Conference, NWPC 2007, Roskilde, Denmark
- [8] <http://www.windplatform.eu/>

Contact

Pierre Pinson, pp@imm.dtu.dk

5.5.2 Forecast Uncertainty Point Forecasting of Wind Generation

Technical description

Brief technology description

Research developments on the forecasting of wind power generation started 15-20 years ago. Since then, multiple methodologies have been developed. Commercial tools are now available, distributed and maintained by a certain number of companies (or research institutes) in Europe. Forecasting is still an important (and very active) research field, being the main point of focus of several European research projects. More information on wind power forecasting can be found in Wikipedia [1], an overview of the main methodologies is available in [2], and a state of the art on research developments (up to 2003) is available in [3]. Forecasts of wind generation are provided in the form of point predictions ie. a single value (either the expected or the most likely wind generation) for each look-ahead time. Another IT measure actually focuses on point forecasting of wind power. Because of the low (in average) and highly variable level of accuracy of wind power point forecasts, it appears paramount today to have them associated with a situation-dependent assessment of their uncertainty. This may take the form of probabilistic forecasts [4],[5], which are the most common so far, or alternatively of risk indices [6], which tell forecast users on the confidence they may have in the provided predictions. In both cases, uncertainty information may originate from purely statistical methods, or by post-processing meteorological ensemble forecasts.

Technical/Implementation issues

Uncertainty on wind power forecasts will be provided along with point predictions of wind power. Hence, similarly to wind power forecasting, tools for providing information on forecast uncertainty can be implemented in the form of software installed at the client, or provided as a service by some forecast companies. In both cases, the methods involved require as input static and dynamic information for the site considered (a wind farm, a group of wind farm, or a region). Static information includes:

- Geographical coordinates
- Description of the wind farm layout (or spreading of wind turbines/farms if considering a region, optional)
- Topography/orography/roughness in the vicinity of the wind farm (generally in the form of maps, optional)

Note that such static information is not as important as for the case of point prediction. Uncertainty estimation is more often seen as a statistical post-processing problem, based on the already generated point forecasts. In parallel, dynamic information includes:

- Meteorological forecasts of relevant meteorological variables (wind speed and directions, plus possibly humidity, temperature and pressure) – They may take the form of ensemble forecasts of meteorological variables.
- Availability of the turbines
- Online power measurements (SCADA data, mandatory)
- Online meteorological measurements (SCADA data, optional)

Regarding dynamic information, note that online power measurements are a necessary information if one wants to have a reliable estimation of forecast uncertainty. If not possible to have this information online, power measurement data should be regularly collected and used for adapting/updating the mathematical models involved.

Safety issues

There are no specific safety issues.

Impact***Benefits (and drawbacks/limitations) to power system***

Wind power being a variable source of energy, whose output is imposed by meteorological conditions and not by human control, forecasts are paramount in order to optimally plan the operation of the power system in view of this production. Since the beginning of research developments related wind power forecast uncertainty 5-10 years ago, it has been shown that optimal decisions regarding management or trading of wind power cannot be made without information on forecast uncertainty [7-9]. The only known limitations are the potential lack of expertise of forecast users. Indeed, if one does not know how to make an optimal decision from forecast uncertainty information, there will be no benefit from its use.

Dependence on other measures

Forecast uncertainty is tightly linked to the forecasts themselves. Therefore, the present measure on forecast uncertainty is to be associated to that on wind power point forecasting. In addition, since wind power forecasts serve as a basis for making bids on the Nord Pool electricity market, several studies now start to show what is the influence of wind power predictions on the electricity prices (spot, but mainly regulation ones), see e.g. [10]. As a consequence, the present measure on wind power forecast uncertainty is tightly related to some of the market measures. Evolution of the electricity market in Denmark should account for the fact that wind power producers make their bids from forecasts which are not completely accurate.

Finally, it is important to understand the link between demand (load) and wind power production. Indeed, if the daily patterns for load and wind were fully correlated, this could make the management of the power system significantly easier. Hence, measure related to demand (load) forecasting, or demand-side management, should relate to the present measure on uncertainty of wind power forecasts.

Environmental issues

There are no particular environmental issues.

Business issues

Forecasting of wind generation is now a mature research field, for which R&D efforts are carried out both at research institutes and by commercial forecast providers. Prediction services or software are not only provided as output of research collaborations, but also as fully commercial products. In Denmark, some companies such as ENFOR A/S have been providing forecasts as a commercial software/service since 2006, while such software/service started to be offered few years earlier in Germany, Spain or the United States. Relevant information on forecast uncertainty is only rarely provided so far.

Forecast providers

In Denmark, the companies providing forecasting of wind generation as a service, or as software are:

- ENFOR A/S
- Vejr2 A/S
- WEPROG A/S

Note that a large number of other European companies provide similar services or software, and may be present on the Danish market in the future. ENFOR and WEPROG provide information on forecast uncertainty along with their predictions.

Status

Existing installations (examples if available)

Current users of wind power forecasts in Denmark (thus being clients of commercial forecast providers) include:

- Energinet.dk
- Vattenfall Danmark
- DONG Energy Generation
- Etc.

Most of these forecast users have a long experience with the use of wind power predictions, gained though collaborations with research institutes through Danish and European projects. It is not known if all these forecast users are provided or not with information on forecast uncertainty. If so, it is even less sure that such information is used for optimizing management and trading decisions.

Research and Development

Research and development is very active in the field of wind power forecasting, with focus on various ways of improving the value of wind power predictions for their users. A large part of research efforts focuses on uncertainty of wind power predictions, ie. on better ways of estimating, communicating it, and consequently using it in decision-making processes. A list of recent and current relevant research projects at the Danish and EU level is given below.

Projects

Title	Country	Grant	Year
Wind power ensemble forecasting	Denmark	PSO 2101	2002-2005
Improved wind power prediction	Denmark	PSO 5766	2004-2007
High Resolution Ensembles at Horns Rev	Denmark	PSO 6387	2006-2009
Anemos	EU	FP5	2002-2006
Anemos.plus	EU	FP6	2008-??
SafeWind	EU	FP7	2008-??

An overview of the major ongoing research projects (and coordination actions) at the European level are briefly described and discussed in [11]. Finally, the European Wind Energy Association has set up a technology platform, in which a group of forecasting experts focuses on defining a research agenda in order to reach a breakthrough in development of wind power forecasting technology [12].

Other issues

There are no specific other issues.

References

- [1] http://en.wikipedia.org/wiki/Wind_Power_Forecasting
- [2] L. Landberg, G. Giebel, H.Aa. Nielsen, T.S. Nielsen, H. Madsen (2003). Short-term prediction - An overview. *Wind Energy* 6(3): 273-280
- [3] G. Giebel, G. Kariniotakis, R. Brownsword (2003). State of the art on short-term wind power prediction. Technical Report, Anemos Project Deliverable Report D1.1 [Online: <http://anemos.cma.fr>]
- [4] H.Aa. Nielsen, T.S. Nielsen, H. Madsen (2006). Using quantile regression to extend an existing wind power forecasting system with probabilistic forecasts. *Wind Energy* 9(1-2), pp. 95-108.

- [5] P. Pinson, H.Aa. Nielsen, J.K. Møller, H. Madsen, G. Kariniotakis (2007). Nonparametric probabilistic forecasts of wind power: required properties and evaluation. *Wind Energy* 10(6), pp. 497-516.
- [6] P. Pinson, H.Aa. Nielsen, H. Madsen, G. Kariniotakis (2007). Skill forecasting from ensemble predictions of wind power. *Renewable Energy* (submitted) (available at: www.imm.dtu.dk/~pp)
- [7] P. Pinson, C. Chevallier, G. Kariniotakis (2007). Trading wind generation with short-term probabilistic forecasts of wind power. *IEEE Trans. on Power Systems* 22(3), pp. 1148-1156.
- [8] E. Lindgren, L. Söder (2008). Minimizing regulation costs in multi-area systems with uncertain wind power forecasts. *Wind Energy*, 2008 (in press).
- [9] B. Hasche, R. Barth, D. Jan Swider (2007). Effects of improved wind forecasts on operational costs in the German. In: Proc. Ecomod'07, International Conference on Energy and Environment Modelling Conference, Moscow, Russia.
- [10] T. Jónsson, H. Madsen (2007). The effect of wind power on electricity prices in Denmark. Technical Report, Technical University of Denmark, Informatics and Mathematical Modelling, 2007
- [11] G. Giebel, P. Meibom, P. Pinson, G. Kariniotakis (2007). Towards smart integration of wind generation. In: Proc. Nordic Wind Power Conference, NWPC 2007, Roskilde, Denmark
- [12] <http://www.windplatform.eu/>

Contact

Pierre Pinson, pp@imm.dtu.dk

5.5.3 Load forecasting (electricity and heat consumption)

Technology description

Brief technology description

Load forecasting, load being considered as the demand in terms of electricity or heat, is crucial for the management of the power system. If focusing on the electricity demand, relevant forecast horizons range from 1-hour ahead to 7-day ahead, with an hourly or half-hourly resolution. Over this range of horizons, forecasts have a broad range of applications, going from economic scheduling of power systems to capacity planning and maintenance scheduling. An overview of the electricity demand forecasting problem is given in [1]. Research efforts for the development and improvement of electricity demand forecasting have been significant in the last 20 years, yielding a large number of alternative and competitive methods. Forecast accuracy depends on the size of the overall power system or on the climate of the related region. This point is illustrated and discussed in [2] for instance. For the specific case of European countries, one can find a comparison of expected forecast accuracy in [3]. Typically for these countries, the Mean Absolute Percentage Error (MAPE) is between 1 and 3%, with an increase as the lead time progresses. In parallel, heat load prediction is a less developed research area, as there is a significantly smaller number of countries employing heat networks. Heat load forecasts are crucial for optimizing the flux of hot water at the point of production [4]. In parallel, temperature forecasts at critical points of the distribution network are necessary for the optimization of the water temperature at the production point [5]. Relevant look-ahead times for heat load consumption are up to 72-hour ahead, with a temporal resolution depending on the control system employed at the production point. In terms of forecast accuracy, only few results are available in the relevant literature [6],[7]. Results from a forecasting exercise in Denmark mention a MAPE of up to 17% when no meteorological information is used, and which can be lowered to 3-7% if appropriately accounting for meteorological conditions and their impact of the heat load.

Technical/Implementation issues

Load forecasting can be implemented in the form of software installed at the client, or provided as a service by some forecast companies. In both cases, forecasting methods may require information on consumption in the past, in the form of measurement time-series, as well as information on the meteorological conditions for the coming period, given by predictions for a set of relevant meteorological variables (e.g. temperature or wind).

Safety issues

There are no specific safety issues.

Impact

Benefits (and drawbacks/limitations) to power system

Electricity and heat loads are stochastic variables, thus implying that forecasts are necessary for making optimal decisions in terms of planning or of economic dispatch. In addition, the current level of accuracy of such forecasts makes them directly useable in deterministic decision-making approach. This contrasts with the low level of forecast accuracy in e.g. wind power prediction, which then translates to under-optimal decisions if forecasts are directly used in deterministic decision-making approaches. This does not change the fact that higher

forecast accuracy for the load would permit to increase even more the benefits to the power system as a whole.

Dependence on other measures

Regarding electricity consumption, it is important to understand the link between demand (load) and wind power production. Indeed, if the daily patterns for load and wind were fully correlated, this could make the management of the power system significantly easier. Hence, measures related to demand (load) forecasting, or demand-side management, should relate to measures on short-term forecasting of wind power generation, and its uncertainty. In parallel, heat load forecasting is tightly related to measures on the optimal management of CHP facilities. It can also be related to measures on wind power forecasting (and its uncertainty), as the idea of using CHP as a buffer for wind power variable output would call for the combined use of load and generation forecasts.

Environmental issues

There are no particular environmental issues.

Business issues

Load forecasting is a mature research field. Prediction services or software are not only provided as output of research collaborations, but also as fully commercial products.

Forecast providers

In Denmark, it seems there is a unique company that may provide electricity and load forecasts: ENFOR A/S. However, there exist a large number of other companies in Europe that may be able to provide a similar service.

Status

Existing installations (examples if available)

Current users of load forecasts include Transmission System Operators (TSOs), such as Energinet.dk in Denmark, or heat producers using advanced controllers for hot water flow optimization.

Research and Development

Research and development related to load forecasting is pretty limited at the Danish or European level at the moment. However, this should change in the future, as the idea of demand-side management would call for new methods permitting to account for the consumer behaviour and the impact of price signals on the future load. In parallel, future research works in this area should also focus on the interaction between renewable energies and the load, as the increase of the correlation between these two would allow for an easier management of the overall power system, and also allow for lower electricity prices.

Other issues

There are no specific other issues.

References

- [1] D.W. Bunn (2000). Forecasting loads and prices in competitive power markets. *Proceedings of the IEEE* 88(2): 163-169.
- [2] J.W. Taylor, L.M. de Menezes, P.E. McSharry (2006). A comparison of univariate methods for forecasting electricity demand up to a day-ahead. *International Journal of Forecasting* 22: 1-16.

5.5.3. Load forecasting (electricity and heat consumption)

- [3] J.W. Taylor, P.E. McSharry (2008). Short-term load forecasting methods: an evaluation based on European data. *IEEE Transactions on Power Systems* 22: 2213-2219.
- [4] H. Madsen, K. Sejling, H.T. Sjøgaard, O.P. Palsson (1994). On flow and supply temperature control in district heating systems. *Heat Recovery Systems & CHP* 14: 613-620.
- [5] P. Pinson, T.S. Nielsen, H.Aa. Nielsen, N.K. Poulsen, H. Madsen (2008). Temperature prediction at critical points in district heating systems. *European Journal of Operational Research*, in press.
- [6] E. Dotzauer (2002). Simple model for prediction of loads in district-heating systems. *Applied Energy* 73: 277-284.
- [7] H.Aa. Nielsen, H. Madsen (2000). Predicting the heat consumption in district heating systems using meteorological forecasts. Technical report, Department of Mathematical Modelling, Technical University of Denmark, ENS. J. Nr. 1323/98-0025.

Contact

Pierre Pinson, pp@imm.dtu.dk

5.6 Local Grid Support with Micro Production

Technical description

Brief technology description

Micro Production (MP) is an extension of the distributed generation (DG) concept where the required electrical power in residential applications is produced locally using sources like : solar panel (photovoltaics), micro wind turbines, fuel-cells, micro CHP based on gas-turbines, etc. with an installed power < 10 kW. All these sources of electrical power generate either dc or variable frequency electrical power and in order to connect them to the grid typically a power electronic interface converter (PEIC) is required.

Apart from the main function of converting the generated power to grid synchronized power, these power electronics interface can perform additional functions like:

1. ancillary grid supporting functions such as local voltage and frequency control
2. power quality conditioning functions dealing with compensating the local voltage harmonics and unbalance
3. UPS (Uninterruptable Power Supply) for houses, ensuring power supply during blackouts and improving thus the reliability of the grid
4. Participation in primary or secondary control (as regulating reserves), and reactive power compensation. But due to the low rating of these units, coordinated cluster control is necessary in order to achieve typically ranges of MW for primary or secondary reserves. This is perfectly possible in the near future when a high penetration of MP is expected providing communication and coordinated control

Technical issues

The local grid support technology is very well known from the wind power plants with power electronics grid converters in MW range. Application to MP is only a matter of down-scaling to kW range. It is very relevant the fact that this function can be implemented entirely in software without requesting extra hardware [1]

The power quality conditioning technology is very well known from business area of active filters for utility applications and UPQC (universal power quality conditioner) which is a FACT devices designed to improve the transmission capability of ac lines. The challenge here is to implement this technology at very low scale (<10 kW range) and many papers have already demonstrated that it is possible, typically as an add-on to the existing grid interface converter mostly implemented in software.

UPS systems are very well known technologies available on the market but UPS with MP is still at the R&D level as the market for this kind of application is still small. The technical challenge is that the grid-connected interface converters (for PV, micro-wind, etc) are uni-directional and the converters for stand-alone applications are bi-directional converters working in parallel with a storage system (batteries) being thus more complex and more expensive. An optimal solution would be to use a micro-gas turbine or fuel-cell instead of battery and to avoid thus the need of recharging as these MP are continuously supplied by gas or H₂.

The technical challenges for implementing this measures are mostly in the communication area. Standardized communication protocols and support are required. Compatibility with grid controller is also required

Impact

Benefits (and drawbacks/limitations) to power system

1. Local grid support with MP has the benefit of ensuring the power system stability in the near future where a high penetration is envisaged and central grid control can perform unsatisfactory. Local voltage control can generate flickers so special measures to avoid them should be considered. Another limitation is that both local voltage and frequency control is strongly limited by the VA rating of the MP but is still possible, specially when coordinated MP cluster control is possible.
2. Power Quality Conditioning with MP has the benefit of improving the power quality at a local level without action for the grid operators. The degree of compensating the voltage harmonics and unbalance can be limited by the reduced rating (VA) of the MP but optimized control using coordinated cluster control can improve the performances.
3. UPS control with MP has the benefit of ensuring the power supply of typical residential applications during blackouts by automatically and seamless switching to stand-alone mode. This function is currently implemented using diesel generator or storage based on batteries or fuel cells that are expensive, need maintenance and are very rare used. Providing UPS function using MP is an add-on function to the classical MP avoiding thus the extra cost of a separate UPS system. UPS with MP supplied by renewable energy sources like PV or micro-wind turbine may have limited availability. Combination with MP based on FC or micro gas turbine, or storage could ensure 100% backup supply during blackouts.
4. Coordinated cluster control of MP has the benefit to provide primary or secondary fast reserves or reactive power compensation useful for the grid control. Some availability limitations may apply for MP based on renewable energy sources without back-up but using fast communication the potential of these reserves may be well estimate. Reliability of these types of reserves may be limited as it depends on the communication and reliability of a very high number of units.

Dependence on other measures

Local grid support is depending on the following measures:

- market measure for allowing and paying local voltage and frequency control services
- coordinated MP cluster control for more effective local grid control

Power Quality Conditioning with MP is depending on the following measures:

- market measure for allowing and paying ancillary services of voltage harmonics and unbalance compensation
- coordinated MP cluster control for more effective compensation

UPS control of MP is depending on the following measures:

- Grid regulation incentives for this ancillary service of UPS at residential level

Coordinate cluster control of MP is depending on the following measures:

- market measure for allowing and paying primary or secondary fast reserves (dkk/MW) and for reactive power compensation dkk/MVAR)

Environmental issues

There are no particular environmental issues as it is a control measure implemented in software!

Business issues

The technology is mature and some companies especially in the PV business are offering them especially for MicroGrid application. Integration in the grid is not possible in the moment due to grid regulations which are expected to be changed in the future

Manufacturers (add here more manufacturers!)

- SMA
- Fronius (PV inverters for MicroGrid applications)
- Solar Wind Works
- Distributed energy systems
- Proven energy,

Status

Existing installations

Germany – ISET [1]

Multifunctional PV – ISET – Pilot plant Kassel, 100 kW PV + 100 kWx1h battery (German Ministry for Environment, Federal Ministry for the Environment, Nature Conservation and Nuclear Safety and EC

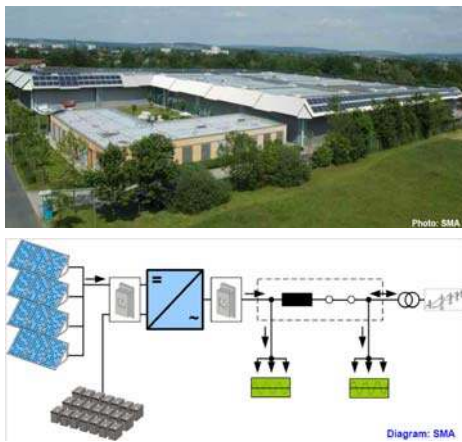

Functionality	With decoupling inductor	Without decoupling inductor
Feed PV to grid	Yes	Yes
Supply of control power	Yes	Yes
Reactive power compensation	No	Yes
Harmonics compensation	No	Yes
UPS	Yes	No
Improvement of local voltage profile	Yes	No

- The Local Grid Support with MP is still not commercially available but is demonstrated in some pilot projects. It is expected to enter the market of MicroGrids in few years

Greece: The Kythnos Island Microgrid.[2]

This system, shown in Figure 2, electrifies 12 houses in a small valley on Kythnos, an island in the Cyclades Archipelago, of the Aegean Sea. The generation system comprises 10 kW of PV, a nominal 53-kWh battery bank, and a 5-kW diesel genset. A second PV array of about 2 kW, mounted on the roof of the control system building, is connected to an SMA inverter and a 32-kWh battery bank to provide power for monitoring and communication. Residential service is

powered by three SMA battery inverters connected in a parallel master-slave configuration forming one strong singlephase circuit. More than one of the 3.6-kW battery inverters is used only when more power is demanded by consumers. The battery inverters can operate in frequency droop mode, allowing information flow to switching load controllers if the battery state of charge is low, and limiting the power output of the PV inverters when the battery bank is full.

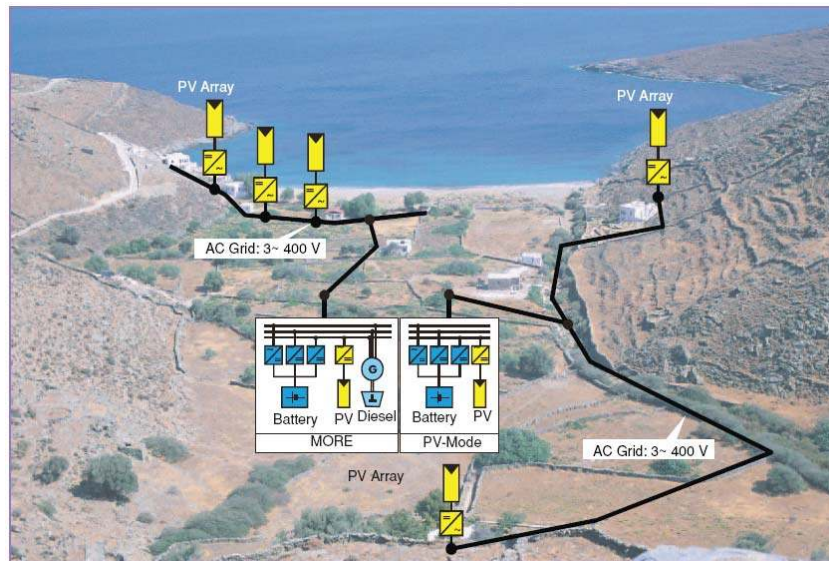

figure 2. Pilot Kythnos microgrid.

Netherlands: Continuum's MV/LV facility. [2]

Continuum operates a holiday camp with more than 200 cottages, equipped with grid-tied PV totaling 315 kW. The cottages are connected to an MV/LV transformer using four approximately 400-m feeders. Daytime loads are low, so most of the PV power is injected into the MV grid. During the evening and night, support from the grid is needed. High voltages at the end of the feeder and a high level of voltage distortion during high PV output have been noted. With the microgrid islanded, improvements in power quality are sought using power electronic flexible ac distribution systems and storage.

Germany: MVV Residential Demonstration at Mannheim-Wallstadt. [2]

The 1,200-inhabitant ecological estate in Mannheim-Wallstadt has been prepared for a continuous long-term field test site for the More Microgrids project. A total of 30 kW of PV has already been installed by private investors, and further DERs are planned. The first goal of the experiment has been to involve customers in load management. During a summer of 2006 2-month trial, more than 20 families and one municipal daycare center participated in the *Washing with the Sun* program (Figure 3). Based on PV output availability information in their neighborhood, customers shifted their loads to times when they could use solar electricity directly. As a result, participating families shifted their loads significantly from the typical residential evening peak toward hours with higher solar insolation, and from cloudy days toward sunny days.

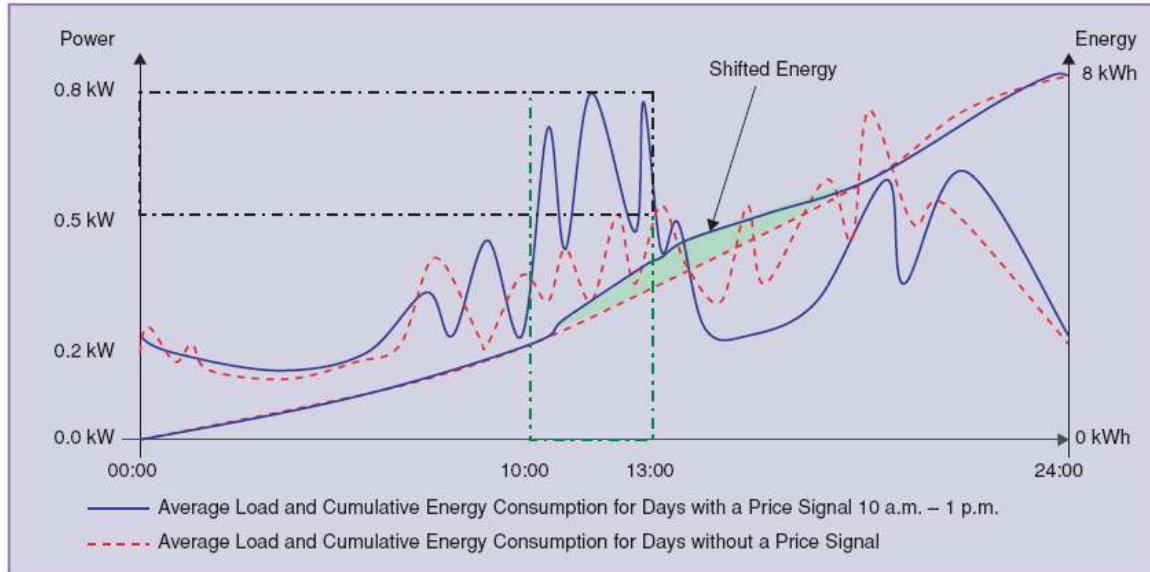

figure 3. *Washing with the Sun* encouraged customers to shift loads to high solar generation periods (source: MVV Energie).

The CERTS Microgrid (CM) is intended to, as seamlessly as possible, separate from normal utility service during a disruption and continue to serve its critical internal loads until acceptable utility service is restored. The CM provides this function for relatively small sites ($\sim <2$ MW peak) without need for costly fast electrical controls or expensive site-specific engineering. No single device is essential for operation, creating a robust system.

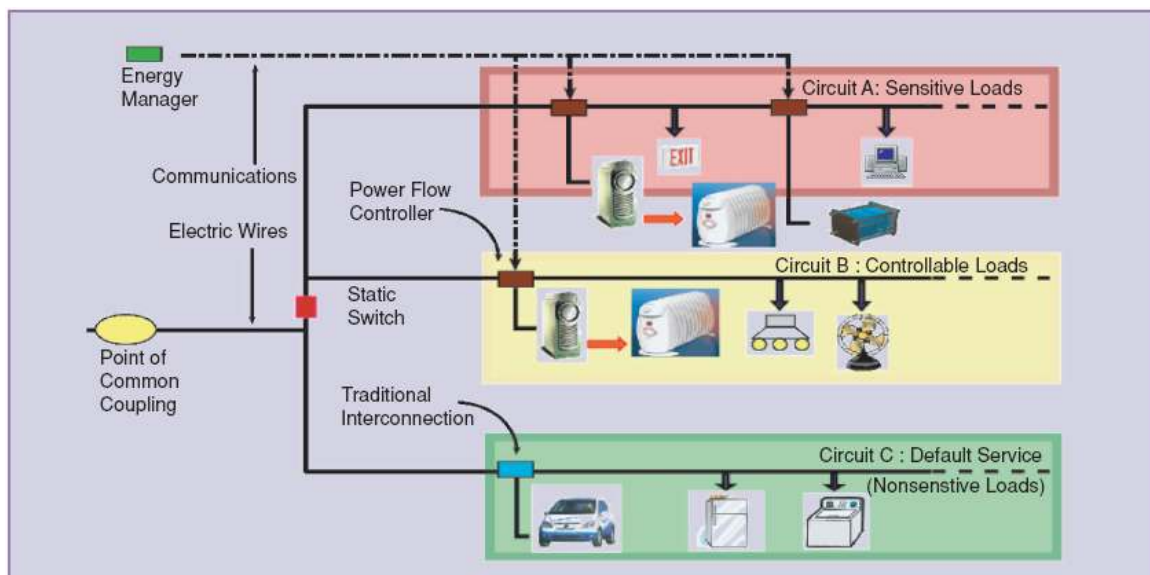

figure 4. Schematic of an example CM (source: CERTS).

Figure 4 shows an example CM, whose salient features are:

- *a lack of fast electrical controls.* The operation of generators is controlled locally by power electronic devices incorporating droop characteristics that respond to locally monitored frequency and voltage. Consequently, devices that naturally require a power electronic interface, e.g., dc sources, are particularly amenable to incorporation in a CM.

- *a single point of common coupling (PCC), and does not export.* To the utility the CM appears as a single controlled load, no different than similar “customers.”
- *an explicit design to provide heterogeneous PQR.* This appears in the diagram as varying reliability on the three circuits. Circuit C is exposed to normal grid power; however, in the event of inadequate grid power quality, e.g. voltage sag, the static switch opens and circuits A and B are served as an intentional island until acceptable power quality is restored.
- *a dispersed plug-and-play system.* No custom engineering is required for interconnection of any single device, as long as it has CM capability, making system configuration flexible and variable. Generators may not only be spread across circuits, they may be physically placed around the site, quite possibly co-located with convenient heat sinks that offer economically attractive CHP opportunities.
- *generic slow controls.* Other control functions, e.g., maintaining economic dispatch, are achieved by a slow control network, represented in Figure 4 as the *Energy Manager*, which could be of many types; e.g., an add-on to a legacy building energy management system.

Japan - The Aomori Project in Hachinohe

This microgrid was put into operation in October 2005 and is being evaluated for PQR, cost effectiveness, and GHG emission reductions over a planned demonstration period lasting until March 2008. Figure 10 gives an overview of the microgrid central feature of the system is that only renewable energy sources, including PV, WTs (together totaling 100 W), and biomass, are used to supply electricity and heat. The controllable DERs consist of three 170-kW gensets (510

kW total) burning sewage digester gas, a 100-kW lead-acid battery bank, and a 1.0-t/h woody biomass boiler. The microgrid serves seven City of Hachinohe buildings. These facilities are interconnected through a 6-kV, 5.4-km duplicate distribution line, with the whole system connected to the commercial grid at a single PCC. From November 2005 and July 2006, primary energy consumption was reduced by 57.3%, thanks to reduced electricity purchases, while carbon emissions were also reduced by 47.8%. A weeklong islanding test is planned during the project period. The energy management system developed through this project optimally meets building demands for electricity and heat by controlling the output of the gensets and boilers, together with the charging and discharging of the battery bank. The control objective is to minimize operating costs and CO₂ emissions while maintaining constant power flow at the PCC.

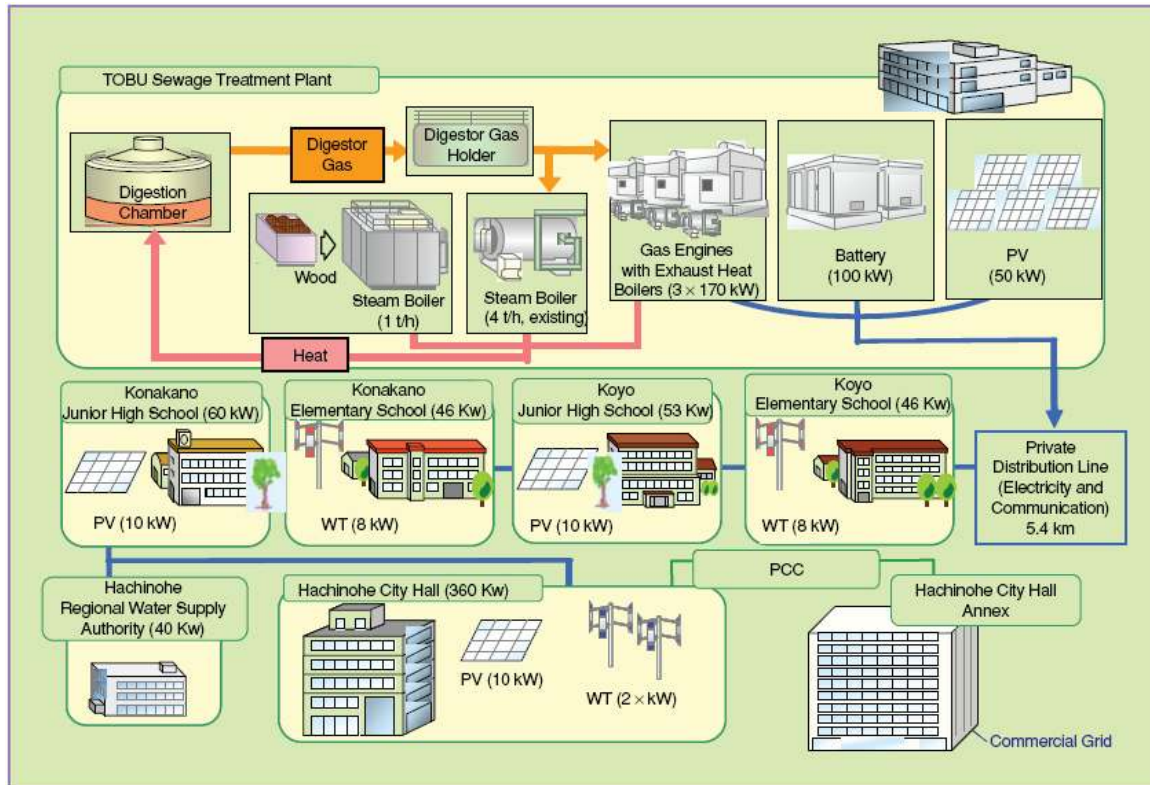

figure 10. Overview of the Aomori project.

The Aichi Project near the Central Japan Airport

The first NEDO demonstration project started operation at the site of the 2005 World Exposition in March 2005. The system was moved to the Central Japan Airport City near Nagoya in 2006, where it began operation in early 2007. It now supplies a Tokoname City office building and a sewage plant via a private distribution line. Its main feature is a combination of the following fuel cells as the main sources: two [270-kW and 300-kW molten carbonate fuel cells (MCFCs)], four 200-kW phosphoric acid fuel cells (PAFCs), and a 50-kW solid oxide fuel cell (SOFC). The MCFCs use biogas generated from high temperature (1,200 °C) treatment of wood waste and plastic bottles. Both the MCFCs and SOFC are baseloaded while the PAFCs load follow. Total PV capacity is 330 kW, and a 500-kW NAS battery is used for balancing. Experiment results of intentional islanding mode have also been obtained.

The Kyoto Project at Kyotango

The municipal government of Kyotango City, north of Kyoto, leads this first virtual microgrid demonstration project covering a 40-km span called the *Kyoto Eco Energy Project*, which started operation in December 2005. It incorporates the following generation capacities: 50-kW of PV, 50 kW of WTs, 5 × 80-kW biogas gensets, a 250-kW MCFC, and a 100-kW battery bank. An energy control center communicates with the DERs by internet protocol over the legacy telecom network to balance demand and supply, and energy is fed into the legacy distribution system. Imbalances can currently be rectified over 5-minute time-steps, and shorter ones are planned.

Shimizu Corporation, a major commercial building construction company, with the cooperation of the University of Tokyo, is developing a microgrid control system using a test

microgrid at its research center in Tokyo. The DERs include two natural gas gensets of 90 kW and 350 kW, 4 × 100-kW-400-kJ electric double layer capacitors, and a 200-kW × 2-h NiMH battery bank. The principle project objective is to develop an optimum operation and control system. The target market includes urban developments, university campuses, and high PQR demanding facilities, such as hospitals, banks, data centers, etc.

References

- [1] http://www.iset.uni-kassel.de/pls/w3isetdad/www_iset_new.main_page?p_lang=eng&p_name=7231008
- [2] Nikos Hatziargyriou, Hiroshi Asano, Reza Iravani, and Chris Marnay. An Overview of Ongoing Research, Development, and Demonstration Projects. July/August 2007
- [3] <http://certs.lbl.gov/>
- [4] European Commission (Apr. 2006), “European SmartGrids technology platform: Vision and strategy for Europe’s electricity networks of the future” [online]. Available: http://ec.europa.eu/research/energy/pdf/smartgrids_en.pdf.
- [5] <http://www.ornl.gov/sci/btc/apps/Restructuring/TM2002-242.pdf>
- [6] <http://certs.lbl.gov/pdf/phase2-kueck.pdf>
- [7] <http://cetc-varenes.nrcan.gc.ca/fichier.php/codectec/En/2005-187/2005-187e.pdf>

Contacts

Remus Teodorescu, ret@iet.aau.dk.

5.7 Phasor Measurement units (PMUs)

Technical description

Brief description

A phasor measurement unit (PMU) is a device that provides synchronized measurements of real-time phasors of voltages and currents along with a measurement of the frequency. Synchronism between the individual PMUs is achieved by the use of a common synchronizing signal from GPS satellites. The synchronization of the sampling process for different waveforms, which may be hundreds of kilometres apart, makes it possible to put their phasors on the same phasor diagram.

According to IEEE standard for PMUs, the accuracy limits of PMUs, defined in terms of Total Vector Error (TVE), should be within 1%. This implies a phase error within ± 0.01 rad ($\pm 0.57^\circ$) or a maximum time error of $\pm 26\mu\text{s}$ [B1]. This high accuracy of the PMU elevates the standards of power system monitoring, control, and protection to a new level [B2]. The current and potential applications of phasor measurement units have been well documented [B3], [B4].

The greatest impact from PMUs on power system lies in applications that utilize the unique capabilities of PMUs to provide synchronized measurements at dispersed locations in the grid. Such applications require PMU data to be collected at a control centre where the analysis of the data can be carried out. A system of PMUs must be supported by communication infrastructure of sufficient speed to match the fast streaming PMU measurements.

In power systems where the amount of renewable power production has significantly been increased, the existing transmission system is not always designed to cope with the new transmission requirements. In many cases, it would be desirable to strengthen existing transmission system. Due to an increasing political and public resistance against further expansion of the high voltage transmission grid, future expansions could possibly be limited. Another possible solution could be an operation of the existing transmission system closer to the stability limits for the system which requires a trustworthy online monitoring of these limits. This necessitates a research within the field of applications for on-line assessment of power system stability. It is attractive to base such applications on wide area PMU measurements since they provide a direct measure of the operating state of the system.

Grid connection

The grid connection of the PMUs is obtained by the use of transducers that scale the signals of interest. The PMUs receive the waveform of currents and voltages from current transformers and potential transformers respectively.

Technical data

The IEEE standard for synchrophasors for Power Systems addresses the definition of a synchronized phasor, time synchronization, applications of time tags and method to verify measurement compliance with the standard. In order to test the compliance of a PMU with the standard, the table below can be used. The table shows the range of the influence quantity (frequency, magnitude or phase) and allowable error limits for compliance level 1 [B1].

Influence Quantity	Reference Condition	Range of influence quantity with respect to reference and maximum allowable TVE in percent	
		Range	TVE (%)
Signal Frequency	F_{nominal}	$\pm 5\text{Hz}$	1%
Signal Magnitude	100% rated	80% to 120%	1%
Phase angle	0 radians	$\pm\pi$ radians	1%

The TVE (Total Vector Error) defined as shown below:

$$TVE = \sqrt{\frac{(X_r(n) - X_r)^2 + (X_i(n) - X_i)^2}{X_R^2 + X_i^2}}$$

Where $X_R(n)$ and $X_i(n)$ are the measured values given by the measuring device and X_R and X_i are the theoretical values of the input signal at the time of measurement.

Safety issues

Not relevant for PMUs.

Impact

Benefits to power system

The technology of PMUs has matured in recent years. Their practical value is given by applications of their measurements and are some of those applications listed below [B3],[B4]:

- **Real Time monitoring and Control:**
One of the benefits of PMUs is the ability to inform not only operators that they face problems in their control areas, but as well neighbouring operators of a stressed grid. In [B5] is presented a Wide-Area stability and voltage Control System (WACS) that is intended to provide a flexible platform for rapid implementation of generator tripping and reactive power compensation switching for transient stability and voltage support of a large power system.
- **Power System State Estimation:**
PMUs offers a number of benefits to the State Estimation application such as improved accuracy and robustness of bad data detection; availability of a faster numerical solution to a linear problem [B6][B7][B8][B9].
- **Real-time congestion management:**
The common practice for real-time congestion management is to compare actual flow on a line or a path against a Nominal Transfer Capability (NTC) which is calculated in advance using offline methods. Such calculations are often based on thermal limitations, voltage limitations or stability limitations whichever is most restrictive for the given case. The assumptions used in NCT are often conservative and can result in large excessive margins in the congestion management process. This may lead to unused transfer capability and lost opportunity to reduce costs in the dispatch process.
PMU measurements can offer significant benefits within the area of real-time transmission congestion management by enabling improved calculations of path limits and path flows. This can lead to significant saving through reduced congestion and more optimum system dispatch.
- **Benchmarking, validation and fine-tuning of system models:**
The implementation of phasor measurement based tools, methods and applications provides a means of improving existing models. The availability of precise and time synchronized measurements from various locations in the power system provides new opportunities for identifying errors in system modelling data and for fine tuning

power system power system models utilized throughout the industry for both on-line and off-line applications.

- **Post-disturbance analysis:**
The aim of a post-mortem or post-disturbance analysis is to reconstruct the sequence of events after a power system disturbance has occurred. For this purpose, a team of engineers assembles and studies the recordings from various data recorders that are dispersed throughout the grid. Since the recorders are not synchronized, the job of understanding and reconstructing a timeline of what happened becomes a time consuming job. A utilization of synchronized measurements can make this process significantly easier.
- **Power System Restoration:**
Under the process of power restoration, system operators often encounter an excessive phase angle difference across a breaker which connects two adjacent stations. Closing a breaker on a large angle difference can shock the system and cause severe equipment damage. The PMUs are well suited for on-line monitoring of angles, and thus quite helpful during a power restoration. The PMU can reduce the time needed during a restoration process.
- **Global and Inter-Area oscillations:**
Several methods have been suggested for both on-line and off-line analysis of power system oscillations which utilize PMU data. Methods that have been applied for the detection and identification of oscillations are among others prony analysis and wavelet analysis.
- **Adaptive Protection:**
Using synchronized phasor measurements, certain relays and protection schemes could be made to adapt to the prevailing system conditions, thereby enhance their performance.

Figure 1 shows a schematic overview over both existing and potential applications of PMU data.

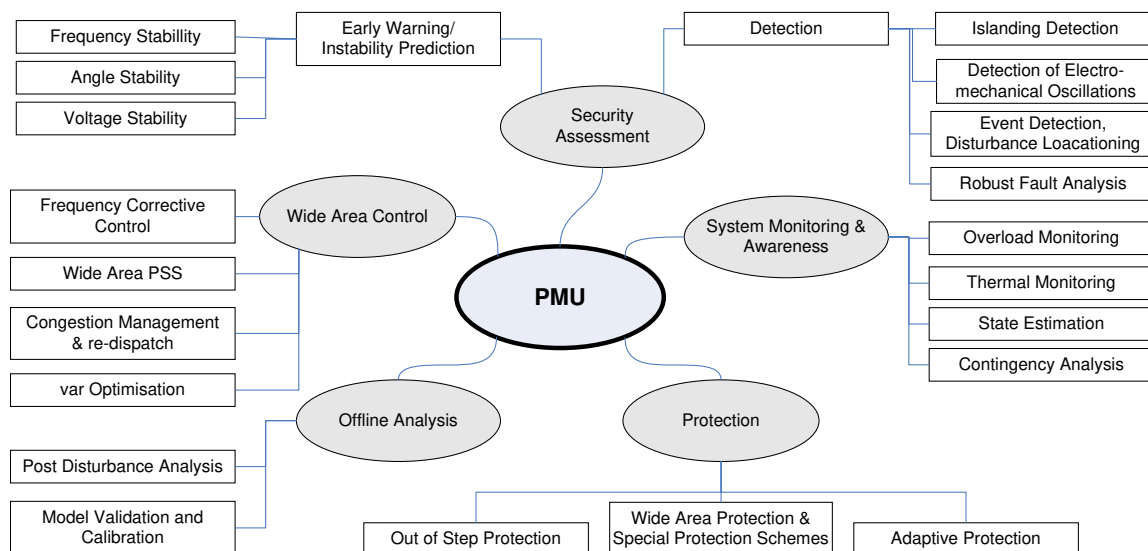

Figure 1: Schematic view over both existing and potential applications of PMU data. All of the applications are on-line applications except for the two under the “Offline Analysis” category.

Dependence on other measures

For applications that utilize PMU measurements from widespread locations, the reliability of the communication system is of great importance. Another factor influencing the phasor

measurements is the performance of the measurement transformers that provide the signal that the PMUs measure.

Environmental impact

The PMUs have no direct environmental impact. It is though possible that the PMUs might have a secondary impact, since PMU measurements are used for real-time congestion management and thus contributing to power savings in the dispatch process.

Business issues

Manufacturers

ABB, Arbiter Systems, Macrodyne inc., Schweitzer Engineering Laboratories inc., GE Multilin.

Patents

The PMU technology is a non patented technology.

Status

Existing installations (examples if available)

In the list below are give examples over some of the existing installations around the world.

Place	Time	Capacity	Function	Ref
Canada (Hydro Quebec)			Post-mortem analysis, validation and fine tuning of simulation models, frequency regulation statistics	[B10]
USA (BPA)			Wide Area Monitoring, Test of PMU performance, Post disturbance analysis, Simulation validation.	[B11]
USA (WECC)			Disturbance monitoring, System condition monitoring.	[B12],
Italy (TERNA)			Parameter Identification	[B13]
Switzerland (ETRANS)			Line Thermal Monitoring, Event Capture	
Denmark (ENDK)			PMU Measurement Methods, Model Verification, Stability Assessment.	[B14]
China			Generator Operation Status Monitoring, Oscillations analysis, State Estimation, Power angle stability prediction and Alarming, Online perturbation identification.	[B15]

Potential development

Some examples of potential applications which can utilize the benefits offered by PMUs are listed below:

- Situational awareness applications
- Wide-Area Power System Stabilizer
- Early Warning for instability
- Real Time Frequency Corrective Control
- Wide-Area Generator Protection System

Research and development

Examples of PMU-related research projects:

Title	Country	Grant	Period
EIPP (Eastern Interconnection Phasor Project)	USA		2002-?
A Tool for On Line Stability Determination and Control for Coordinated Operating between Regional Entities Using PMUs	USA		June 1, 2005 to August 31, 2007.
Detection, Prevention and Mitigation of Cascading Events – Prototype Implementations	USA		June 1, 2006 - August 31, 2008
Development of PMU-based Early Warning System for electric power systems	Denmark		April 2007-may 2010

Bottlenecks

When PMU data is to be used for control of power systems, the reliability of the communication system becomes critical. A secure and robust communication system is needed to ensure that PMU data can be transmitted reliably and sufficiently fast for real time applications. The communication system needed for PMU based real time applications might therefore be considered as a bottleneck for the practical implementation of such applications.

Other issues

References

Bibliography

- [B1] Adamiak, M. G., Anderson, S., Begovic, M., Benmouyal, G., Burnello, G., Burnett Jr, R. O., Burger, J., Jim, C. Y., Dickerson, W., Gharpure, V., Karlson, D., Bill, K., Phadke, A. G., Salj, J., Skendzig, V., and Sperr, J., "Standard for Synchrophasors for Power Systems: IEEE Std C37.118-2005," *Power Delivery, IEEE Transactions on*, vol. 13, no. 1, pp. 73-77, 2005.
- [B2] Heydt, G. T., Liu, C. C., Phadke, A. G., and Vittal, V., "Solution for the crisis in electric power supply," *Computer Applications in Power, IEEE*, vol. 14, no. 3, pp. 22-30, 2001.
- [B3] Skok, S., Ivankovic, I., and Cerina, Z., "Applications Based on PMU Technology for Improved Power System Utilization," *Power Engineering Society General Meeting, 2007.IEEE*, pp. 1-8, 2007.
- [B4] CIGRE Working Group C4.601. Wide Area Monitoring and Control for Transmission Capability Enhancement. C.Rechtanz, Convener. 2007. CIGRE Technical Brochure. Ref Type: Report
- [B5] Taylor, C. W., Erickson, D. C., Martin, K. E., Wilson, R. E., and Venkatasubramanian, V., "WACS-Wide-Area Stability and Voltage Control System: R&D and Online Demonstration," *Proceedings of the IEEE*, vol. 93, no. 5, pp. 892-906, 2005.
- [B6] Nuqui, R. F. State Estimation and Voltage Security Monitoring Using Synchronized Phasor Measurements. 2001. Ref Type: Report
- [B7] Abur, A., "Distributed State Estimation for Mega Grids," *15th Power Systems Computations Conference*, Aug.2005.
- [B8] Zhao, L. and Abur, A., "Multi area state estimation using synchronized phasor measurements," *Power Systems, IEEE Transactions on*, vol. 20, no. 2, pp. 611-617, 2005.

- [B9] Phadke, A. G., Thorp, J. S., and Karimi, K. J., "State Estimation With Phasor Measurements," *IEEE Transactions on Power Systems*, vol. PWRS-1, no. No. 1, Feb.1986.
- [B10] Kamwa, I., Beland, J., Trudel, G., Grondin, R., Lafond, C., and McNabb, D., "Wide-area monitoring and control at Hydro-Quebec: past, present and future," *Power Engineering Society General Meeting, 2006.IEEE*, pp. 12, 2006.
- [B11] Martin, K. E., Hauer, J. F., and Faris, T. J., "PMU Testing and Installation Considerations at the Bonneville Power Administration," *Power Engineering Society General Meeting, 2007.IEEE*, pp. 1-6, 2007.
- [B12] Martin, K. E., "Phasor measurement systems in the WECC," *Power Engineering Society General Meeting, 2006.IEEE*, pp. 7, 2006.
- [B13] Candia, C., Cirio, D., Giannuzzi, G., Pozzi, M., and Sforna, M., "PMU Location and Parameter Identification Techniques for the Italian Wide-Area Measurement System," *International World Energy System Conference, Turin, Italy, 2006*.
- [B14] Rasmussen, J. and Jorgensen, P., "Synchronized Phasor Measurements of a Power System Event in Eastern Denmark," *Power Systems, IEEE Transactions on*, vol. 21, no. 1, pp. 278-284, 2006.
- [B15] Xie, X., Xin, Y., Xiao, J., Wu, J., and Han, Y., "WAMS applications in Chinese power systems," *IEEE Power & Energy Magazine*, vol. 4, no. 1, pp. 54-63, 2006.

Contacts

Hjörtur Jóhannsson, hj@elektro.dtu.dk

5.8 Real time state estimators

Technical description

Brief technology description

A real-time model is a quasi-static mathematical representation of the current conditions in a power network. This model is extracted at intervals from snapshots of real time measurements (analog measurements and the status of switching devices) as well as static network data (basic configuration and parameters). State estimation is the key function for obtaining such a real-time network model.

The first step in real time modelling is the establishment of the dynamic database. This is performed by the data acquisition function, which processes both analog and status data. Analog measurements include power flows, power injections, voltage magnitudes, phase angles, and current magnitude measurements, whereas the status data consists of data concerning the network configuration. The static data base contains network basic configuration data along with parameter data (e.g. line impedances). If a state variable can be calculated from the available data (both dynamic and static) it is considered to be observable.

Technical/Implementation issues

Traditionally state estimation in power network is based on a methodology from numerical analysis. The problem is formulated as a least squares problem in which the focus in a large part of the Literature is on solving this in an efficient way. The problems involved is related to invert a large matrix efficiently, handle constraints and solve large scale problems.

Safety issues

There are no specific safety issues.

Impact

Benefits (and drawbacks/limitations) to power system

In conventional state estimation the real-time model is obtained from observable part of the network and optionally to attach the external model to it. With a proper redundancy level state estimation can eliminate the effect of bad data and allow the temporary loss of measurements without significantly affecting the quality of the estimated values. State estimation is mainly used to filter redundant data, to eliminate incorrect measurements, to produce reliable state estimates and allows to a certain extend determination of power flows in parts of the network that is not directly metered.

Dependence on other measures

The state estimation is based on measurements on the electric network and is off course dependent at the availability of these measurements. The newer versions of state estimation are based on phase information and depend on the PMU measure.

Environmental issues

There are no particular environmental issues.

Business issues

Status

Existing installations (examples if available)

Research and Development

The area has been an active research area since 1970 ([2]-[4]) and has been more important after the deregulation of the energy market. The introduction of PMU has improved the applications of state estimation.

Other issues

There are no specific other issues.

References

- [1] A. Montielli (1999): State Estimation in Electric Power Systems, A Generalized Approach. Kluwer Academic Publishers.
- [2] F.C. Schweppe (1970): Power System Static-State Estimation, Part 1: Exact Model, *IEEE Transaction on Power Apparatus and Systems*, Vol 89, No 1, pp. 120-125.
- [3] F.C. Schweppe (1970): Power System Static-State Estimation, Part 2: Approximate Model. *IEEE Transaction on Power Apparatus and Systems*, Vol 89, No 1, pp. 125-130.
- [4] F.C. Schweppe (1970): Power System Static-State Estimation, Part 3: Implementation. *IEEE Transaction on Power Apparatus and Systems*, Vol 89, No 1, pp. 130-135.
- [5] A. Montielli (2000): Electric Power State Estimation. Proceedings of the IEEE, Vol. 88, No. 2, pp. 262-282.

Contacts

Pierre Pinson, pp@imm.dtu.dk

Niels Kjølstad Poulsen, nkp@imm.dtu.dk

Arne Hejde Nielsen, ahn@elektro.dtu.dk

5.9 Stability assessment / Contingency analysis

Technical description

Brief technology description

It certainly appears crucial to Transmission System Operators (TSOs) that the system should be operated in a continuous manner, and thus constantly prevented from reaching a point at which it may collapse. Indeed, liberalization of electricity exchanges combined to the quest for maximum economical efficacy may lead to the use of interconnection capacities far above levels expected when they were built. Since the system is operated closer and closer to its physical limits, tools and methods allowing for reliable and fast detection of potential emergency events become paramount.

The most traditional deterministic approach for contingency analysis is certainly that based on the “N-1” criterion. Indeed it corresponds to possible events. This criterion stipulates amongst other things that in its state “N”, that is to say when all elements of the system are in operation, operating conditions are in accordance with rules. Generally this is tested for different conventional states: at least for peak and off-peak load of the system, etc. It implies further that for all types of incidents leading to the disconnection of only one element (generator, circuit, line, transformer, etc.), the system operating point stays within the requested area. The operating point and the system is then declared “-1” secure. This approach is often “generalized” considering, at least for some devices, the loss of more than one element, turning the criterion from “N-1” to “N-2”, to “N-x”. In these cases, the system operating area is generally enlarged, considering some overload capabilities of system elements. When “x”, the number of lost elements, is getting higher, the state of the system can be driven far away from its normal acceptable conditions. The unfolding of such incidents leads to operation of emergency controls, which can represent a difficult undertaking for traditional contingency analysis methodology.

However, as more and more stochastic generation (e.g. wind, solar) are fed into the system, this traditional deterministic approach may not be suitable anymore. It is for instance starting to be accepted today that worst events (for a system largely penetrated by stochastic generation) may not occur at peak and off-peak loads, but instead during highly unstable and hardly predictable meteorological phenomena. New methodologies allowing to assess stability of the system and risk in the coming period are (and should further) be developed. An example of a thorough study on voltage instability detection for the case of Eastern Denmark is available in [3].

Benefits (and drawbacks/limitations) to power system

Benefits for the system are here straightforward, as knowing limitations and potential risk of failure are paramount for insuring continuous delivery of electricity.

Dependence on other measures

The possibility for contingency analysis and stability assessment in real-time is strongly conditioned on availability of large-number of relevant synchronized measurements (e.g. from

PMUs), and on methods for real-time state estimation giving a snapshot of the current state of the system.

Technical/Implementation issues

Such issues will be relevant when methods will be sufficiently developed. So far, they consist more of offline analyses investigating on limitations of the system.

Environmental issues

There are no particular environmental issues.

Safety issues

There are no specific safety issues.

Business issues

Business issues are most probably irrelevant here, as TSOs would certainly prefer to have such tools and methods developed, tested, and employed in-house. This allows them to have full control, in addition to have them tailored to their systems and their needs.

Existing installations (examples if available)

Research and Development

Projects

Bottlenecks

Other issues

There are no specific other issues.

References

- [1] J. Deuse, K. Karaoui, A. Bihain, J. Dubois. Comprehensive approach of power system contingency analysis. Proc. PowerTech 2003, IEEE Conference, Bologna, Italy.
- [2] U.G. Knight (2001). *Power Systems in Emergencies, From Contingency Planning to Crisis Management*. John Wiley & Sons, Chichester, England.
- [3] J. Rasmussen (2006). *System Protection Schemes in Eastern Denmark*. PhD Thesis, Ørsted-CET, Technical University of Denmark.

Contacts

Pierre Pinson, pp@imm.dtu.dk

Hjörtur Jóhannsson, hj@elektro.dtu.dk