

# Economic implications of alternative scholarly publishing models:

## Exploring the costs and benefits

JISC EI-ASPM Project

**A report to the Joint Information Systems Committee  
(JISC)**

**John Houghton, Bruce Rasmussen and Peter Sheehan**  
Centre for Strategic Economic Studies,  
Victoria University

**Charles Oppenheim, Anne Morris, Claire Creaser,  
Helen Greenwood, Mark Summers and Adrian Gourlay**  
Information Science, LISU and Economics,  
Loughborough University

January 2009

Contact:

[John.Houghton@pobox.com](mailto:John.Houghton@pobox.com)

[C.Oppenheim@lboro.ac.uk](mailto:C.Oppenheim@lboro.ac.uk)

## **Acknowledgements**

The authors would like to acknowledge the support of the UK Joint Information Systems Committee (JISC), particularly Neil Jacobs, and thank the expert project review group, including Matthew Cockerill, Fred Friend, Malcolm Gillies, Paul Hubbard, Donald King, Danny Quah and Astrid Wissenburg for their comments and suggestions.

The research team included Australian and UK-based groups.

- The Australian team included John Houghton, Bruce Rasmussen and Peter Sheehan of The Centre for Strategic Economic Studies at Victoria University in Melbourne, together with Colin Steele, Emeritus Fellow at The Australian National University in Canberra; and
- The UK team included Charles Oppenheim and Anne Morris of the Department of Information Science, Claire Creaser, Helen Greenwood and Mark Summers of LISU, and Adrian Gourlay of the Department of Economics, at Loughborough University.

The team benefited from the very generous contributions of Bo-Christer Björk of the Hanken School of Economics in Helsinki, and Donald King of the University of North Carolina.

The work builds on that undertaken as a part of a project funded by the then Australian Department of Education, Science and Training, and the authors would like to acknowledge that contribution.

## **Disclaimer**

While every effort has been made to ensure its accuracy, neither Victoria University nor Loughborough University make any representations or warranties (express or implied) as to the accuracy or completeness of the information contained in this report. Victoria and Loughborough Universities, their employees and agents accept no liability in negligence for the information (or the use of such information) which is provided in this report.

# Contents

|   |            |
|---|------------|
| <b>SUMMARY</b> .....  | <b>IX</b>  |
| <b>1 INTRODUCTION</b> .....   | <b>1</b>   |
| 1.1 APPROACH TO THE STUDY .....   | 2          |
| 1.1.1 <i>Phase I: Identification of costs and benefits</i> .....  | 2          |
| 1.1.2 <i>Phase II: Quantification of costs and benefits</i> .....   | 3          |
| 1.2 EMERGING MODELS FOR SCHOLARLY PUBLISHING .....  | 5          |
| 1.2.1 <i>Alternative publishing models</i> .....  | 6          |
| 1.3 THE SCHOLARLY COMMUNICATION PROCESS .....   | 11         |
| 1.3.1 <i>Descriptions of the scholarly communication process</i> .....  | 11         |
| 1.3.2 <i>The scholarly communication process model</i> .....  | 22         |
| <br>  |            |
| <b>PART I: IDENTIFICATION OF COSTS AND BENEFITS</b> .....   | <b>29</b>  |
| <b>2 IDENTIFYING COSTS</b> .....  | <b>29</b>  |
| 2.1 FUND RESEARCH AND RESEARCH COMMUNICATION .....  | 29         |
| 2.1.1 <i>Processes involved in funding research</i> .....   | 30         |
| 2.1.2 <i>Identification of the costs involved in funding research</i> .....   | 33         |
| 2.1.3 <i>Funding flows relating to funding research</i> .....   | 36         |
| 2.1.4 <i>The impacts of alternative publishing models on research funding activities</i> .....                          | 37         |
| 2.2 PERFORM RESEARCH AND COMMUNICATE THE RESULTS .....  | 38         |
| 2.2.1 <i>Processes involved in performing research and communicating results</i> .....                                  | 39         |
| 2.2.2 <i>Identification of the costs involved in performing research and communicating results</i> ....                 | 43         |
| 2.2.3 <i>Funding flows relating to performing research</i> .....  | 46         |
| 2.2.4 <i>The impacts of alternative publishing models on research and communication activities</i> .....                | 47         |
| 2.3 PUBLISH SCIENTIFIC AND SCHOLARLY WORKS .....  | 49         |
| 2.3.1 <i>Processes involved in publishing scientific and scholarly works</i> .....                                      | 50         |
| 2.3.2 <i>Identification of the costs involved in publishing scientific and scholarly works</i> .....                    | 63         |
| 2.3.3 <i>Funding flows relating to scientific and scholarly publishing</i> .....  | 76         |
| 2.3.4 <i>The impacts of alternative publishing models on scholarly publishing activities</i> .....                      | 79         |
| 2.4 FACILITATE DISSEMINATION, RETRIEVAL AND PRESERVATION .....  | 85         |
| 2.4.1 <i>Processes involved in facilitating dissemination, retrieval and preservation</i> .....                         | 86         |
| 2.4.2 <i>Identification of the costs involved in facilitating dissemination, retrieval and preservation</i><br>95       |            |
| 2.4.3 <i>Funding flows relating to dissemination, retrieval and preservation</i> .....                                  | 100        |
| 2.4.4 <i>The impacts of alternative publishing models on dissemination, retrieval and preservation activities</i> ..... | 101        |
| 2.5 STUDY PUBLICATIONS AND APPLY KNOWLEDGE .....  | 102        |
| 2.5.1 <i>Processes involved in studying publications and applying knowledge</i> .....                                   | 103        |
| 2.5.2 <i>Identification of the costs involved in studying publications and applying knowledge</i> ....                  | 112        |
| 2.5.3 <i>Funding flows relating to study and application</i> .....  | 115        |
| 2.5.4 <i>The impacts of alternative publishing models on studying and application activities</i> .....                  | 116        |
| <br>  |            |
| <b>3 IDENTIFYING POTENTIAL BENEFITS</b> .....   | <b>117</b> |
| 3.1 DIMENSIONS OF IMPACT AND BENEFIT .....  | 117        |
| 3.2 IMPACTS AND POTENTIAL BENEFITS IDENTIFIED IN THE LITERATURE .....   | 121        |
| 3.2.1 <i>Access issues and limitations</i> .....  | 122        |
| 3.2.2 <i>Access, downloads and citation</i> .....   | 123        |
| 3.2.3 <i>Access and the wider use of scientific and scholarly works</i> .....   | 125        |
| 3.2.4 <i>Permissions and limitations on use</i> .....   | 125        |
| 3.2.5 <i>The conduct and record of science</i> .....  | 127        |

|  |  |            |
|--|--|------------|
| 3.3  | IDENTIFICATION OF IMPACTS AND POTENTIAL BENEFITS .....   | 127        |
| 3.3.1  | <i>Fund research and research communication</i> .....  | 127        |
| 3.3.2  | <i>Perform research and communicate results</i> .....  | 129        |
| 3.3.3  | <i>Publish scientific and scholarly works</i> .....  | 131        |
| 3.3.4  | <i>Facilitate dissemination, retrieval and preservation</i> .....  | 133        |
| 3.3.5  | <i>Study and apply knowledge</i> .....   | 134        |
| 3.4  | A BRIEF SUMMARY OF IMPACTS AND POTENTIAL BENEFITS.....   | 135        |
| <br><b>PART II: QUANTIFICATION OF COSTS AND BENEFITS .....</b> |  | <b>139</b> |
| <b>4</b>   | <b>QUANTIFYING COSTS.....</b>  | <b>139</b> |
| 4.1  | FUND RESEARCH AND RESEARCH COMMUNICATION .....   | 139        |
| 4.1.1  | <i>Funding and agencies</i> .....  | 140        |
| 4.1.2  | <i>Evaluation</i> .....  | 141        |
| 4.1.3  | <i>Institutional</i> .....   | 142        |
| 4.1.4  | <i>Resources</i> .....   | 142        |
| 4.1.5  | <i>The implications of alternative publishing models for research funders</i> .....  | 142        |
| 4.2  | PERFORM RESEARCH AND COMMUNICATE THE RESULTS .....   | 145        |
| 4.2.1  | <i>Perform research</i> .....  | 145        |
| 4.2.2  | <i>Communicate research</i> .....  | 148        |
| 4.2.3  | <i>The publisher-related activities of researchers</i> .....   | 148        |
| 4.2.4  | <i>Research infrastructure</i> .....   | 150        |
| 4.2.5  | <i>The perform and communicate research cost implications of alternative publishing models</i><br>151                      |            |
| 4.3  | PUBLISH SCIENTIFIC AND SCHOLARLY WORKS .....   | 153        |
| 4.3.1  | <i>Journals</i> .....  | 153        |
| 4.3.2  | <i>Books</i> .....   | 159        |
| 4.3.3  | <i>The current situation</i> .....   | 164        |
| 4.3.4  | <i>The publisher cost implications of alternative publishing models</i> .....  | 165        |
| 4.3.5  | <i>Cost savings and impacts</i> .....  | 165        |
| 4.3.6  | <i>Competition impacts</i> .....   | 169        |
| 4.4  | FACILITATE DISSEMINATION, RETRIEVAL AND PRESERVATION .....   | 169        |
| 4.4.1  | <i>Research library costs</i> .....  | 170        |
| 4.4.2  | <i>Repository costs</i> .....  | 175        |
| 4.4.3  | <i>The dissemination, retrieval and preservation facilitation cost implications of alternative publishing models</i> ..... | 177        |
| 4.5  | SYSTEM COST COMPARISONS .....  | 182        |
| 4.5.1  | <i>System cost comparisons</i> .....   | 182        |
| 4.5.2  | <i>The flow of funds</i> .....   | 188        |
| 4.5.3  | <i>Costs of activities, objects and functions</i> .....  | 190        |
| <b>5</b>   | <b>QUANTIFYING BENEFITS.....</b>   | <b>193</b> |
| 5.1  | MODELLING AND ESTIMATING THE IMPACTS .....   | 193        |
| 5.1.1  | <i>An outline of the model</i> .....   | 193        |
| 5.1.2  | <i>Estimating the impacts</i> .....  | 199        |
| 5.1.3  | <i>Modelled impacts on returns to R&amp;D</i> .....  | 208        |
| <b>6</b>   | <b>COMPARING COSTS AND BENEFITS.....</b>   | <b>211</b> |
| 6.1  | CETERIS PARIBUS SCENARIOS.....   | 213        |
| 6.1.1  | <i>OA publishing (UK national and Higher Education)</i> .....  | 213        |
| 6.1.2  | <i>OA self-archiving (UK national and Higher Education)</i> .....  | 214        |
| 6.2  | NET COST SCENARIOS.....  | 215        |
| 6.2.1  | <i>OA publishing articles (Higher Education)</i> .....   | 216        |
| 6.2.2  | <i>OA publishing articles (UK National)</i> .....  | 217        |
| 6.2.3  | <i>OA self-archiving articles (Higher Education)</i> .....   | 217        |
| 6.2.4  | <i>OA self-archiving articles (UK National)</i> .....  | 218        |

|   |  |            |
|---|--|------------|
| 6.2.5   | <i>Alternative OA publishing models in UK higher education</i> ..... | 218        |
| 6.3   | FAQS.....  | 219        |
| 6.3.1   | <i>Diversion of research funds to ‘author-pays’</i> .....            | 219        |
| 6.3.2   | <i>Impact of delays in delayed OA</i> .....                          | 219        |
| 6.3.3   | <i>Speeding up the research and discovery process</i> .....          | 220        |
| <b>SUMMARY, CONCLUSIONS AND RECOMMENDATIONS .....</b> |  | <b>222</b> |
| <b>7</b>  | <b>SUMMARY .....</b>   | <b>222</b> |
| 7.1   | UK NATIONAL SCHOLARLY COMMUNICATION COSTS .....                      | 222        |
| 7.2   | UK HIGHER EDUCATION SCHOLARLY COMMUNICATION COSTS.....               | 223        |
| 7.3   | THE IMPACT OF ALTERNATIVE SCHOLARLY PUBLISHING MODELS .....          | 224        |
| 7.4   | COMPARING COSTS AND BENEFITS .....                                   | 226        |
| 7.5   | IMPLICATIONS FOR UK HIGHER EDUCATION .....                           | 228        |
| <b>8</b>  | <b>CONCLUSIONS AND RECOMMENDATIONS .....</b>                         | <b>231</b> |
| 8.1   | CONCLUSIONS .....  | 231        |
| 8.2   | RECOMMENDATIONS .....  | 232        |
| 8.2.1   | <i>Overcoming the barriers</i> .....                                 | 232        |
| 8.2.2   | <i>Realising the benefits</i> .....                                  | 232        |
| 8.2.3   | <i>Sharing the gains</i> .....                                       | 233        |
| 8.2.4   | <i>Further research</i> .....  | 233        |
| <b>LIST OF ACRONYMS.....</b>                          |  | <b>235</b> |
| <b>COLLECTED ASSUMPTIONS .....</b>                    |  | <b>236</b> |
| <b>REFERENCES .....</b>                               |  | <b>241</b> |

## Tables

|              |  |      |
|--------------|--|------|
| Table S-I:   | Estimated annual UK national scholarly communication activity costs (GBP, circa 2007).....                           | xi   |
| Table S-II:  | Estimated annual UK higher education scholarly communication activity costs (GBP, circa 2007).....                   | xii  |
| Table S-III: | Estimated annual UK higher education scholarly communication infrastructure-related costs (GBP, circa 2007).....     | xiii |
| Table S-IV:  | Estimated per item object costs (GBP, circa 2007).....   | xiv  |
| Table S-V:   | Summary of benefit/cost comparisons by scenario and model (GBP millions and benefit/cost ratio).....                 | xxi  |
| Table 1.1:   | Typology of open access journal models.....  | 9    |
| Table 2.1:   | Funding research and communication: major costs items.....   | 35   |
| Table 2.2:   | Perform research and communicate results: major cost items.....  | 45   |
| Table 2.3:   | Journal publishing costs identified by EPS et al.....  | 67   |
| Table 2.4:   | Journal publishing costs identified by Clarke.....   | 68   |
| Table 2.5:   | Publish scientific and scholarly works: major cost items (Journals).....   | 73   |
| Table 2.6:   | Publish scientific and scholarly works: major cost items (Books).....  | 75   |
| Table 2.7:   | Dissemination, retrieval and preservation: major cost items.....   | 99   |
| Table 2.8:   | Study and apply knowledge: major cost items.....   | 114  |
| Table 4.1:   | Estimated annual costs: Fund research and communication (GBP, circa 2007).....                                       | 142  |
| Table 4.2:   | Estimated annual costs: Perform research and communicate results – research related (GBP, circa 2007).....           | 147  |
| Table 4.3:   | Estimated annual costs: Perform research and communicate results – publisher related (GBP, circa 2007).....          | 149  |
| Table 4.4:   | Estimated annual costs: Perform research and communicate results – research grants (GBP, circa 2007).....            | 150  |
| Table 4.5:   | Estimated average publisher costs per article by format and model (GBP, circa 2007)                                  | 159  |
| Table 4.6:   | Estimated average publisher costs per title by format and model (GBP, circa 2007)..                                  | 163  |
| Table 4.7:   | Estimated publisher costs of UK research output (GBP, circa 2007).....   | 165  |
| Table 4.8:   | OA versus toll access journals: cost estimates by mode and model (GBP, circa 2007)                                   | 166  |
| Table 4.9:   | OA versus toll access monographs: cost estimates by mode and model (GBP, circa 2007).....                            | 168  |
| Table 4.10:  | Estimated journal related library activity costs per title (GBP, 2006-07).....                                       | 171  |
| Table 4.11:  | Estimated journal related SCONUL library activity costs (GBP, 2006-07).....  | 172  |
| Table 4.12:  | Estimated journal acquisition and handling costs in UK HE (GBP, 2006-07).....  | 174  |
| Table 4.13:  | Estimated OA self-archiving costs (GBP, circa 2007).....   | 176  |
| Table 4.14:  | Potential cost implications of OA publishing for UK higher education (GBP, circa 2007).....                          | 181  |
| Table 4.15:  | Activities along the value chain by publishing model.....  | 182  |
| Table 4.16:  | Estimated UK Higher Education costs by publishing model per item (GBP, circa 2007)                                   | 184  |
| Table 4.17:  | Estimated UK savings by publishing model: Journals and books (GBP millions, circa 2007).....                         | 186  |
| Table 4.18:  | Estimated UK savings by publishing model: Journals only (GBP millions, circa 2007)                                   | 187  |
| Table 4.19:  | Estimated per item object costs (GBP, circa 2007).....   | 191  |
| Table 5.1:   | Estimates of private and social rates of return to private R&D.....  | 205  |
| Table 5.2:   | Estimates of the impacts of a one-off increase in accessibility and efficiency on returns to R&D (GBP millions)..... | 209  |
| Table 6.1:   | Summary of benefit/cost comparisons by scenario and model (GBP millions and Benefit/Cost ratio).....                 | 216  |
| Table 6.2:   | Summary of benefit/cost comparisons: FAQs.....   | 219  |

|            |   |     |
|------------|---|-----|
| Table 7.1: | Estimated annual UK national scholarly communication activity costs (GBP, circa 2007).....                        | 222 |
| Table 7.2: | Estimated annual UK higher education scholarly communication activity costs (GBP, circa 2007) .....               | 223 |
| Table 7.3: | Estimated annual UK higher education scholarly communication infrastructure-related costs (GBP, circa 2007) ..... | 224 |
| Table 7.4: | Summary of benefit/cost comparisons by scenario and model (GBP millions and Benefit/Cost ratio).....              | 227 |

## Figures

|               |   |       |
|---------------|---|-------|
| Figure S-I:   | Do research, communicate and apply results .....  | x     |
| Figure S-II:  | Estimated per item object cost shares (per cent) .....                                    | xiv   |
| Figure S-III: | Estimated average publisher costs per article by format and model (GBP, circa 2007) ..... | xvi   |
| Figure S-IV:  | Approximate academic book publisher cost shares: print (per cent).....                    | xvii  |
| Figure S-V:   | Scholarly communication system costs per article (GBP, circa 2007) .....                  | xviii |
| Figure S-VI:  | Estimated annual costs and cost savings: OA publishing (GBP millions, 2007) .....         | xix   |
| Figure 1.1:   | The evolution of scholarly communication.....   | 5     |
| Figure 1.2:   | Pathways of information and funding flows .....   | 12    |
| Figure 1.3:   | The Garvey-Griffith model outlined by Crawford <i>et al</i> .....                         | 13    |
| Figure 1.4:   | The traditional and 1980s models of scholarly publishing .....                            | 14    |
| Figure 1.5:   | The new model of scholarly publishing, circa 1998 .....                                   | 15    |
| Figure 1.6:   | Scientists' communication cycle (Adapted from Griffith and King, 1993) .....              | 16    |
| Figure 1.7:   | Life-cycle of scientific information through the scholarly journal system functions.....  | 17    |
| Figure 1.8:   | Journal publishing activities and flows .....   | 20    |
| Figure 1.9:   | Book publishing activities and flows .....  | 21    |
| Figure A:     | The scholarly communication process.....  | 24    |
| Figure A0:    | Do research, communicate and apply results .....  | 24    |
| Figure A1:    | Fund research and communication .....   | 30    |
| Figure A11:   | Set policy and direction .....  | 31    |
| Figure A12:   | Evaluate research proposals/grant applications .....                                      | 32    |
| Figure A14:   | Evaluate impacts and outcomes .....   | 33    |
| Figure 2.1:   | Simplified funding flows relating to research funding.....                                | 36    |
| Figure A2:    | Perform research and communicate results.....   | 39    |
| Figure A21:   | Perform research .....  | 40    |
| Figure A22:   | Communicate the knowledge.....  | 41    |
| Figure A221:  | Communicate results informally .....  | 41    |
| Figure A222:  | Communicate results formally (prepare for publication) .....                              | 42    |
| Figure A223:  | Share data / models .....   | 43    |
| Figure 2.2:   | Simplified funding flows relating to performing research .....                            | 47    |
| Figure A3:    | Publish scientific / scholarly works .....  | 49    |
| Figure A31:   | Publish as a journal article .....  | 50    |
| Figure A311:  | Publishers' general activities (Journal).....   | 51    |
| Figure A312:  | Journal specific activities .....   | 52    |
| Figure A313:  | Process article .....   | 53    |
| Figure A3132: | Peer review (Article).....  | 54    |
| Figure A314:  | Produce and process non-article content .....   | 55    |
| Figure A315:  | Technical phases of publishing (Journal).....   | 56    |
| Figure A3154: | Distribute issue / article (Open Access) .....  | 56    |
| Figure A3155: | Duplicate and distribute issue / article (Toll Access).....                               | 57    |
| Figure A33:   | Publish as a monograph .....  | 58    |
| Figure A333:  | Publish as a book.....  | 59    |
| Figure A3331: | Publishers' general activities (Book).....  | 60    |
| Figure A3332: | Editorial / peer review.....  | 61    |



## Economic implications of alternative scholarly publishing models

|                 |  |     |
|-----------------|--|-----|
| Figure A3335:   | Technical phases of publishing (Book).....   | 61  |
| Figure A33355:  | Duplicate and distribute (Book) .....  | 62  |
| Figure 2.3:     | Simplified funding flows relating to subscription publishing .....   | 77  |
| Figure 2.4:     | Simplified funding flows relating to author-pays publishing.....   | 78  |
| Figure 2.5:     | Simplified funding flows relating to publishing scholarly monographs .....   | 79  |
| Figure A4:      | Facilitate dissemination, retrieval and preservation.....  | 86  |
| Figure A41:     | Facilitate dissemination .....   | 87  |
| Figure A42:     | Facilitate retrieval .....   | 88  |
| Figure A421:    | Facilitate retrieval globally .....  | 88  |
| Figure A4211:   | Make publications or data available to subscribers/buyers .....  | 89  |
| Figure A4212:   | Make publications or data openly available .....   | 90  |
| Figure A4213:   | Integrate metadata in search services .....  | 91  |
| Figure A422:    | Facilitate retrieval locally.....  | 92  |
| Figure A4222:   | Making toll access publications available internally.....  | 93  |
| Figure A4223:   | Making open access publications available internally .....   | 94  |
| Figure A43:     | Facilitate preservation.....   | 95  |
| Figure 2.6:     | Simplified funding flows relating to facilitating dissemination, retrieval and preservation.....                             | 100 |
| Figure A5:      | Study publication and apply knowledge .....  | 103 |
| Figure A51:     | Study publication .....  | 103 |
| Figure A511:    | Find out about the publication.....  | 104 |
| Figure A5111:   | Search for interesting publications.....   | 105 |
| Figure A5112:   | Be alerted to publications.....  | 106 |
| Figure A513:    | Retrieve publication .....   | 106 |
| Figure A514:    | Read and process publication.....  | 107 |
| Figure A5142:   | Read publication .....   | 108 |
| Figure A51421:  | Read for research purposes.....  | 109 |
| Figure A514215: | Publish secondary accounts.....  | 109 |
| Figure A52:     | Apply the knowledge .....  | 110 |
| Figure A521:    | Educating professionals .....  | 111 |
| Figure A522:    | Make policy and regulate .....   | 111 |
| Figure A524:    | Apply in practice.....   | 112 |
| Figure 2.7:     | Simplified funding flows relating to studying and applying.....  | 115 |
| Figure 3.1:     | An impacts framework: subscription publishing versus open access .....   | 118 |
| Figure 3.2:     | Dimensions of impact and benefit: access and permission .....  | 119 |
| Figure 3.3:     | UK Economic Impact Reporting Framework .....   | 121 |
| Figure 4.2:     | Approximate per article publisher cost shares: dual-mode subscription publishing (per cent) .....                            | 156 |
| Figure 4.3:     | Estimated average publisher costs per article by format and model (GBP, circa 2007) 158                                      |     |
| Figure 4.4:     | Approximate academic book publisher cost shares: print (per cent) .....  | 160 |
| Figure 4.5:     | Approximate academic book publisher and distribution cost shares: with distributor discounts included, print (per cent)..... | 163 |
| Figure 4.7:     | Estimated average per title library handling costs by format and model (GBP, 2006-07) 171                                    |     |
| Figure 4.8:     | Estimated distribution of journal handling costs by activity (per cent).....   | 173 |
| Figure 4.9:     | Estimated HE library journal handling costs by format and model (GBP, 2006-07)...  | 178 |
| Figure 4.10:    | Estimated annual costs and cost savings: OA publishing (GBP millions, 2007) ....   | 188 |
| Figure 4.11:    | Estimated per item object cost shares (per cent) .....   | 191 |
| Figure 5.1:     | Chain Link model of commercial innovation .....  | 199 |
| Figure 6.1:     | Benefit profiles in a transitional model: Increased returns to R&D over 20 years (GBP millions).....                         | 212 |
| Figure 6.2:     | Benefit profiles in a steady-state model: Increased returns to R&D over 20 years (GBP millions).....                         | 212 |
| Figure 6.3:     | Conceptual map of benefit/cost scenarios.....  | 215 |
| Figure 7.1:     | Scholarly communication system costs per article (GBP, circa 2007) .....   | 225 |



## Boxes

|          |  |       |
|----------|--|-------|
| Box S-I: | Areas for further research .....   | xxvii |
| Box 3.1: | The Open Access Advantage.....   | 124   |
| Box 4.1: | Estimation assumptions: Fund research and communication .....                    | 141   |
| Box 4.2: | Scenario assumptions: Fund research and communication.....                       | 143   |
| Box 4.3: | Estimation assumptions: Perform research and communicate results .....           | 146   |
| Box 4.4: | Scenario assumptions: Perform research and communicate results.....              | 152   |
| Box 4.5: | Estimation assumptions: Publish scholarly works (Journals) .....                 | 154   |
| Box 4.6: | Estimation assumptions: Publish scholarly works (Monographs) .....               | 161   |
| Box 4.7: | Scenario assumptions: Publish scholarly works .....                              | 169   |
| Box 4.8: | UK Special Libraries .....   | 179   |
| Box 4.9: | Scenario assumptions: Facilitate dissemination, retrieval and preservation ..... | 179   |
| Box 5.1: | Model parameter: Percentage change in accessibility .....                        | 202   |
| Box 5.2: | Model parameter: Percentage change in efficiency .....                           | 204   |
| Box 5.3: | Model parameter: Rate of return to R&D and other parameters.....                 | 207   |
| Box 6.1: | A brief description of the model.....  | 211   |



## Summary

A knowledge economy has been defined as: “...one in which the generation and exploitation of knowledge has come to play the predominant part in the creation of wealth. It is not simply about pushing back the frontiers of knowledge; it is also about the more effective use and exploitation of all types of knowledge in all manner of economic activities” (DTI 1998). In a knowledge economy, innovation and the capacity of the system to create and disseminate the latest scientific and technical information are important determinants of prosperity (David and Foray 1995; OECD 1997).

Scholarly publishing plays a key role, as it is central to the efficiency of research and to the dissemination of research findings and diffusion of scientific and technical knowledge. But, advances in information and communication technologies are disrupting traditional models of scholarly publishing, radically changing our capacity to reproduce, distribute, control, and publish information. *The key question is whether there are new opportunities and new models for scholarly publishing that would better serve researchers and better communicate and disseminate research findings* (OECD 2005, p14).

## Aims and approach

Debate on the economics of scholarly publishing and alternative publishing models has focused almost entirely on costs. And yet, from an economic perspective, the aim is to have the most cost-effective system, not (necessarily) the cheapest, and however much one studies costs one cannot know which is the most cost-effective system until one examines both costs and benefits. Hence, *the aim of this project was to examine the costs and benefits of three alternative models for scholarly publishing (i.e. subscription publishing, open access publishing and self-archiving)*. In so doing, it seeks to inform policy discussion and help stakeholders understand the institutional, budgetary and wider economic implications.

The project involved two major phases:

- *Phase I: Identification of costs and benefits* – sought to describe the three models of scholarly publishing, identify all the dimensions of cost and benefit for each of the models, and examine which of the main players in the scholarly communication system would be affected and how they would be affected; and
- *Phase II: Quantification of costs and benefits* – sought, where possible, to quantify the costs and benefits identified; identify and where possible quantify the cost and benefit implications for each of the main players in the scholarly communication system; and, where possible, compare the costs and benefits of the three models.

While wide-ranging in scope, an important focus for the work was the implications of the three publishing models for UK higher education and for scholarly journal and book publishing – although other forms of publication and other stakeholders are included in the analysis.

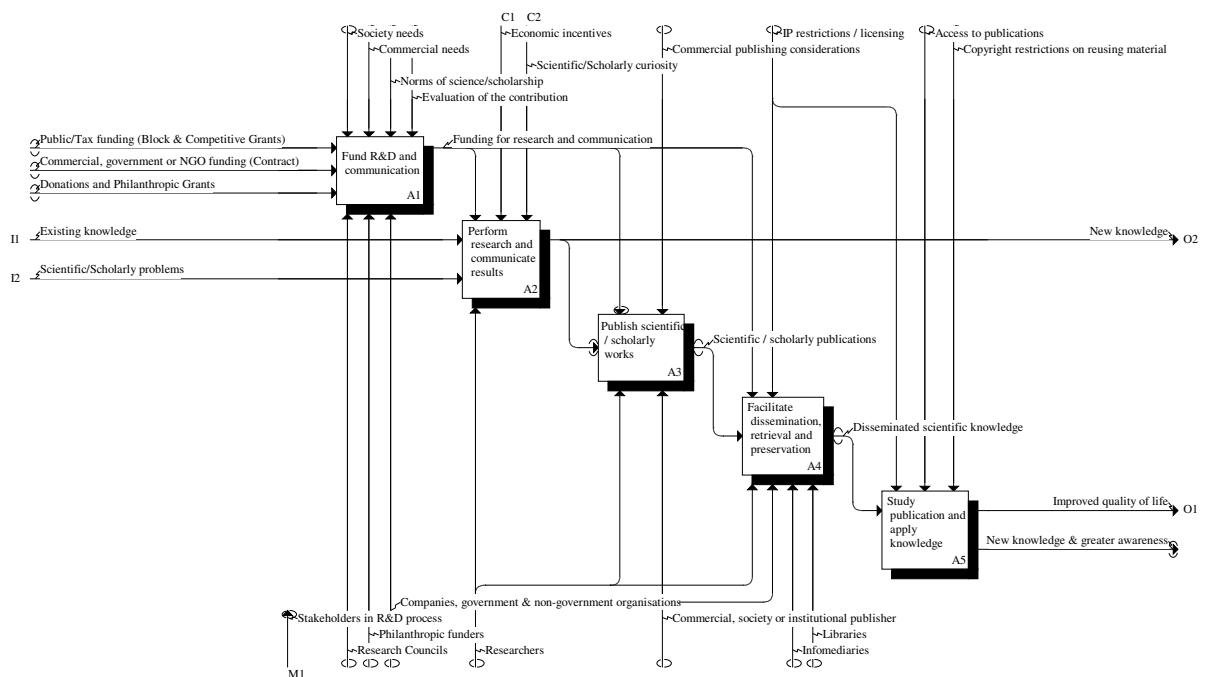
## The scholarly communication process

In order to provide a solid foundation for analysis we have developed and extended the scholarly communication life-cycle model outlined by Björk (2007).

The scholarly communication process involves conducting research, communicating and applying the results, and in the model developed for this study there are five core activities:

- (i) Fund research and research communication;
- (ii) Perform research and communicate the results;
- (iii) Publish scientific and scholarly works;
- (iv) Facilitate dissemination, retrieval and preservation; and
- (v) Study publications and apply the knowledge (Figure S-I).

Figure S-I: Do research, communicate and apply results



Link: <http://www.cfses.com/EI-ASPM/SCLCM-V7/>

Source: Scholarly Communication Process Model: Authors' analysis.

*This extended scholarly communication process model provides a foundation for a detailed identification of the actors, activities, objects and functions involved in the entire scholarly communication process.* The model is based on that of Bo-Christer Björk (2007) and has

benefited from his very generous assistance in its development. In its current form, the model includes more than 50 diagrams and almost 200 activities (Version 7.0).<sup>1</sup>

## Scholarly communication system costs

Drawing on a wide range of data sources, activity surveys and tracking studies, as well as industry consultation, we estimated costs for activities throughout the scholarly communication process at the national level and for UK Higher Education. We found that these costs are substantial (Table S-I).

The reading of scholarly publications by UK-based researchers and academic staff is a major activity, perhaps costing around £7.7 billion annually, and reading by those actively publishing (*i.e.* approximating reading in order to write) cost around £2.8 billion during 2007.<sup>2</sup> We estimate that writing peer reviewed scholarly publications may have cost around £1.6 billion, and preparing and reviewing research grant applications for the UK Research Councils (RCUK), Wellcome and Leverhulme Trusts alone may have cost around £140 million.

**Table S-I: Estimated annual UK national scholarly communication activity costs (GBP, circa 2007)**

| <i>UK National</i>   | <i>Estimate</i>      |
|--|----------------------|
| Reading (Published Staff)  | 2,775,000,000        |
| Reading (Research Staff)   | 7,729,200,000        |
| Writing (ISI Web of Knowledge based estimate of UK published output) | 1,599,700,000        |
| Peer Review (Scaled to output counts)                                | 202,800,000          |
| Editorial Activities (Scaled to published staff)                     | 63,600,000           |
| Editorial Board activities (Scaled to published staff)               | 7,000,000            |
| Preparing Grant Applications (RCUK, Wellcome & Leverhulme)           | 117,500,000          |
| Reviewing Grant Applications (RCUK, Wellcome & Leverhulme)           | 18,600,000           |
| Publisher Costs (Scaled to output counts)                            | 573,900,000          |
| <b>Total National System</b>   | <b>5,358,200,000</b> |

Source: EI-ASPM model: Authors' analysis.

The peer review of scholarly journal articles and books conducted by UK researchers on behalf of publishers (*i.e.* external peer review activities) probably cost around £200 million during 2007, and the external journal editorial and editorial board activities of researchers around £70 million. We estimate that publisher costs relating to UK-authored publications probably amounted to around £575 million (excluding the external costs noted above). Summing these costs suggests that ***core scholarly publishing system activities may have cost around £5.4 billion in the UK during 2007.***

<sup>1</sup> The entire model in 'browseable' form can be found at: <http://www.cfses.com/EI-ASPM/SCLCM-V7/>

<sup>2</sup> All costs are expressed in 2007 UK pounds and, where necessary, have been converted to pounds using OECD published annual average exchange rates and adjusted to 2007 using the UK consumer price index published by the National Statistical Office. Publisher costs include commercial margins.

Table S-II summarises these same scholarly communication activity costs for UK higher education (HE). It shows that academic staff reading probably cost around £5 billion during 2007, and reading by those actively publishing around £2.5 billion. We estimate that writing peer reviewed scholarly publications in UK higher education cost around £1.5 billion, and preparing and reviewing research grant applications for the Research Councils (RCUK), Wellcome and Leverhulme Trusts alone may have cost around £130 million.

**Table S-II: Estimated annual UK higher education scholarly communication activity costs (GBP, circa 2007)**

| <i>UK Higher Education</i>                                 | <i>Estimate</i>      |
|--|----------------------|
| Reading (Published Staff)                                  | 2,446,000,000        |
| Reading (Academic Staff)                                   | 5,097,500,000        |
| Writing (ISI Web of Knowledge based estimate of HE output) | 1,453,900,000        |
| Peer Review (Scaled to output counts)                      | 178,600,000          |
| Editorial Activities (Scaled to published staff)           | 54,900,000           |
| Editorial Board Activities (Scaled to published staff)     | 6,100,000            |
| Preparing Grant Applications (RCUK, Wellcome & Leverhulme) | 109,500,000          |
| Reviewing Grant Applications (RCUK, Wellcome & Leverhulme) | 17,300,000           |
| Publisher Costs (Scaled to output counts)                  | 517,300,000          |
| <b>Total Higher Education System</b>                       | <b>4,783,800,000</b> |

Source: EI-ASPM model: Authors' analysis.

The peer review of scholarly journal articles and books conducted on behalf of publishers by UK academic staff (*i.e.* external peer review activities) probably cost around £180 million during 2007, and their external journal editorial and editorial board activities around £60 million. We estimate that higher education output-related publisher costs probably amounted to around £515 million (excluding the external costs noted above). Summing these costs suggests that *scholarly publishing system activities may have cost UK higher education around £4.8 billion during 2007.*

## The cost of alternative models

*This study focuses on three alternative models for scholarly publishing, namely: subscription publishing, open access publishing and self-archiving.*

- *Subscription or toll access publishing* refers primarily to academic journal publishing, but includes any publishing business model that imposes reader access charges and use restrictions.
- *Open access publishing* refers primarily to journal publishing where access is free of charge to readers, and the authors, their employing or funding organizations pay for publication. Use restrictions can be minimal as no access toll is imposed.<sup>3</sup>

<sup>3</sup> Open access book publishing is also now emerging, but is still at a rather embryonic stage.

- *Open access self-archiving* refers to the situation where academic authors deposit their work in on-line open access repositories, making it freely available to anyone with internet access. Again, use restrictions can be minimal.

Table S-III summarises a range of scholarly publishing costs relating to each of these publishing models. It shows that for UK higher education, *SCONUL library expenditures amounted to almost £600 million during 2006-07, including £205 million for acquisitions* (i.e. for subscription or toll access payments).

**Table S-III: Estimated annual UK higher education scholarly communication infrastructure-related costs (GBP, circa 2007)**

| <i>UK Higher Education</i>   | <i>Estimate</i> |
|--|-----------------|
| Library acquisition costs (Subscription or toll access publishing) | 204,800,000     |
| Library non-acquisition costs                                      | 392,600,000     |
| Author-pays fees for all journal articles (Open access publishing) | 147,500,000     |
| Current estimated Repository Costs (Open access self-archiving)    | 10,700,000      |
| ICT Infrastructure (Total expenditure)                             | 1,178,700,000   |

Source: EI-ASPM model: Authors' analysis.

*Open access publishing all UK higher education journal article output in 2007 would have cost around £150 million.* Given that it is said that no more than half of open access journals actually charge author fees, perhaps £75 million would have been required for author-side payments. However, if the UK supported open access publishing in proportion to output, the remaining £75 million would have been paid in other forms of institutional support.

Open access self-archiving costs are based on estimated repository costs, which are necessarily no more than approximate. Nevertheless, we estimate that the open access repositories in operation in the UK as of August 2008 may have involved annual costs of around £10 million, and that *a system of institutional repositories in UK higher education in which every institution had one publications-oriented repository and all publications were self-archived once would cost around £20 million per annum* (at 2007 prices and levels of publication output).

## Costing activities, objects and functions

The matrix approach to costing lying behind these activity costs enables their presentation in various forms, including as costs for actors, objects and functions (Section 4.5.3).

For example, combining activity costs to estimate object costs we find that *journal articles cost an estimated average of around £9,600 to produce in the UK circa 2007*, of which around £5,300 related to the direct cost of writing (excluding input research activities, such as reading), £2,900 related to publisher costs and £1,400 to external peer review costs (per article published) (Figure S-II and Table S-IV).



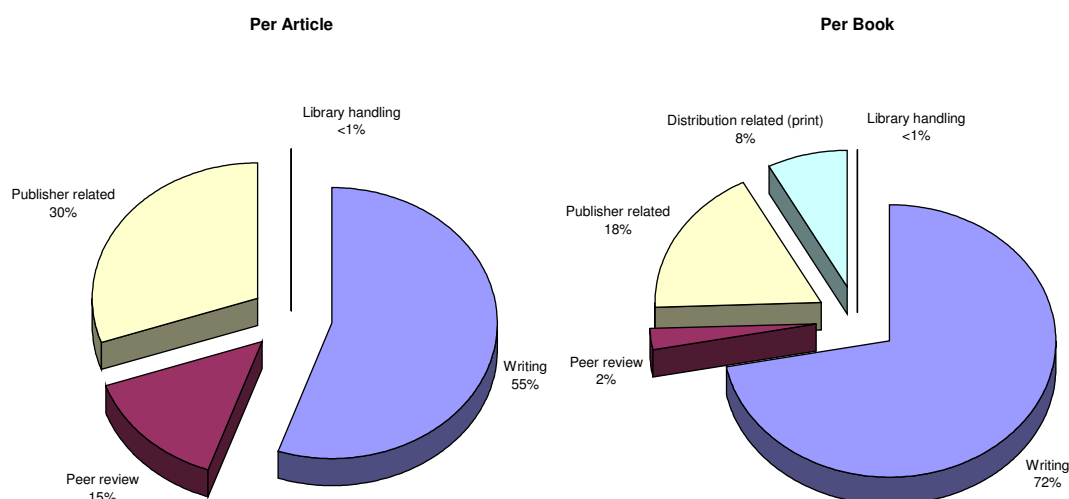
Table S-IV: Estimated per item object costs (GBP, circa 2007)

|   | <i>Estimate</i> |
|---|-----------------|
| <b>Cost per journal article (per article)</b>       |                 |
| Writing   | 5,300           |
| Peer review (per published)                         | 1,400           |
| Publisher related                                   | 2,900           |
| Library acquisition                                 | 0.68            |
| Library handling                                    | 0.43            |
| <i>Per article production</i>                       | <i>9,600</i>    |
| Publisher share of production costs                 | 30%             |
| <b>Cost per research monograph (per title)</b>      |                 |
| Writing   | 63,900          |
| Peer review (per published)                         | 2,100           |
| Publisher related                                   | 15,800          |
| Distribution related (print)                        | 6,800           |
| Library acquisition (books and pamphlets per item)  | 14              |
| Library handling                                    | 74              |
| <i>Per monograph production</i>                     | <i>88,600</i>   |
| Publisher and distributor share of production costs | 25%             |

Note: Writing costs include those items that are not published while all other costs are per item published. Acquisition costs are excluded from the totals to avoid double counting.

Source: EI-ASPM model: Authors' analysis.

Figure S-II: Estimated per item object cost shares (per cent)



Note: Writing costs include those items that are not published while all other costs are per item published. Source: EI-ASPM Model: Authors' analysis.

Similarly, we estimate that *research monographs (i.e. authored and edited books) cost an average of around £88,600 to produce in the UK circa 2007*, of which around £63,900 related to the direct cost of writing (excluding input research activities, such as reading), £15,800

related to publisher costs and an estimated £6,800 to distribution costs, and £2,100 to external peer review costs (per title published) (Figure S-II and Table S-IV).

Activity costs can also be combined into the cost of specific functions, such as peer review and the functions of quality control and certification.<sup>4</sup> The activity cost estimates outlined above include both internal publisher peer review handling and management related costs and external, largely non-cash, peer reviewer costs. Per article published, these amounted to an estimated £344 and £1,388, respectively, or a total function cost of £1,732 circa 2007. For books, these costs are estimated at £1,733 per title for publisher editorial activities and £2,082 for external peer review, or a total function cost of £3,815.

## Publisher costs per journal article

One key challenge is to separate the cost impacts of publishing models from those of format, which is necessary to explore the cost differences between toll and open access publishing models independent of differences between print and electronic production. Our approach is to estimate costs for print, dual-mode (*i.e.* parallel print and electronic) and electronic-only formats for toll and open access business models, and then to compare toll and open access models as if they were all electronic or ‘e-only’. All of these costings include commercial publisher margins.

***For subscription or toll access publishing, we estimate an average publisher cost of around £3,247 per article for dual-mode production, £2,728 per article for print only production and £2,337 per article for e-only production*** (excluding the costs associated with external peer review and VAT) (Figure S-III).

***For open access publishing, we estimate average per article costs at £1,524 for e-only production.*** Excluding the costs of copy printing and delivery, we estimate the cost of dual-mode open access publishing at around £2,000 per article and print only open access publishing at £1,830 per article (Section 4.3.1).<sup>5</sup> Indicatively, if printing and delivery costs were the same as they are for subscription publishing, they might add around £300 per article.

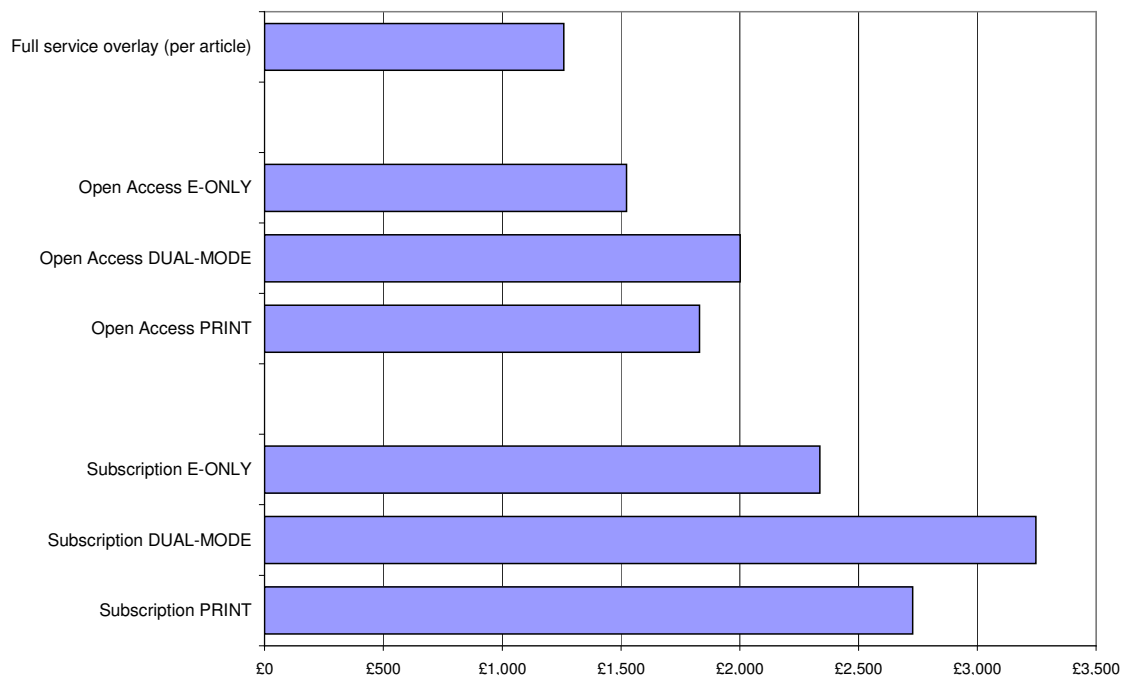
We have included the implied publisher costs of overlay services to open access self-archiving for completeness (*i.e.* elements of publisher activity that could provide value adding overlay services to open access repositories). The same commercial management, investment and profit margins are applied. This shows, for example, that ***operating peer review management, editing, production and proofing as an overlay service would cost around £1,125 per article*** excluding hosting, or £1,260 including hosting.

---

<sup>4</sup> A number of publisher activities relating to the proofing, checking and editing of manuscripts might also be included in the function of quality control, but have been excluded from this example for the sake of simplicity.

<sup>5</sup> It is impossible to estimate the cost of printing and delivery in open access publishing as it depends on the number of copies involved, and in the absence of subscriber counts that number cannot be known. Therefore, estimates for print and dual-mode open access publishing exclude actual copy print and delivery related costs, assuming that the content is produced print ready and print is an add-on.

Figure S-III: Estimated average publisher costs per article by format and model (GBP, circa 2007)



Note: These costs exclude the external costs of peer review and VAT. Overlay services include operating peer review management, editing, proofing and hosting, with commercial margins. Estimates for print and dual-mode open access publishing exclude copy print and delivery related costs, assuming that the content is produced print ready and print is an add-on.

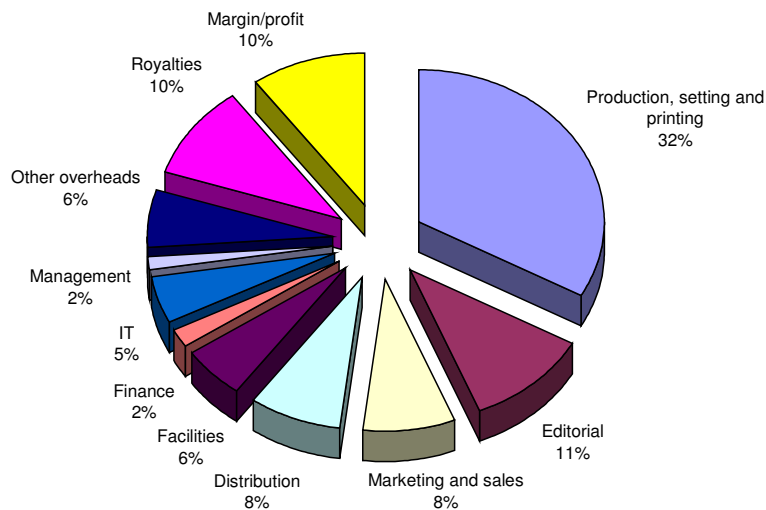
Source: EI-ASPM model: Authors' analysis.

## Publisher costs per book title

Costs relating to academic book publishing are less widely discussed in the literature, although there a number of sources on book publishing costs, publisher management and pricing issues that provide a foundation. It is clear from these sources that book publishing costs vary widely, even within scholarly monograph publishing, between soft and hard backs, with production quality, print runs, sales and so on.

Based on proportions derived from industry consultation and those reported in the literature (Figure S-IV), we estimate average UK publisher Net Sales Revenue at £10,000 to £20,000 in 2007 prices (excluding external peer review costs). Average costs can be summed by format and publishing model, with the cost of toll access book publishing in print form at an estimated average of £15,750 per title. In electronic or e-only format, we estimate toll access publishing costs at an average of around £11,320 per title, and open access publishing around £7,380 per title (Section 4.3.2). These average costs are no more than approximate, but differences between the modes and models are indicative.

Figure S-IV: Approximate academic book publisher cost shares (per cent)



Note: Cost shares of estimated Net Sales Revenue per title, print.

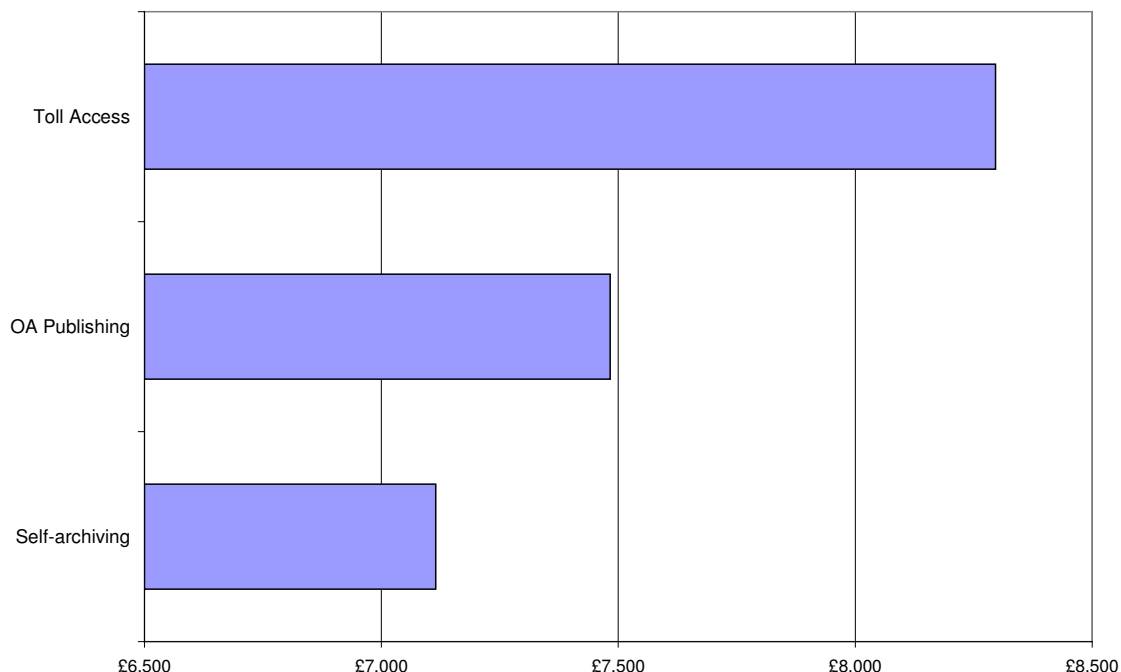
Sources: Industry consultation and Clark (2001). EI-ASPM model: Authors' analysis.

Those difference are accentuated when distributor discounts are taken into account. Academic book publisher discounts to distributors can be substantial, often ranging in the region of 30% to 40%. These discounts should not simply be included in publisher costs, but rather separately identified as distribution or channel costs. For example, if a book sold 500 copies at £45 per copy, a 30% distributor's discount would be worth £13.50 per item or £6,750 per title. Adjusting publisher costs to include distributor discounts brings our estimated average costs per title to £22,500 for print, £14,715 for toll access e-books and an unchanged £7,380 for open access e-books – substantially increasing the difference between publishing models.

## The impact of alternative scholarly publishing models

Summing the costs of production, publishing and dissemination *per article* in electronic-only format suggests that average toll access publishing system costs would amount to around £8,296 per article (excluding VAT), average open access publishing costs would amount to £7,483 per article and average open access self-archiving costs £7,115 per article (including overlay review and production services with commercial margins) (Section 4.5). At these costs, ***open access publishing would be around £813 per article cheaper than toll access publishing, and open access self-archiving with overlay services around £1,180 per article cheaper*** (Figure S-V).

Figure S-V: Scholarly communication system costs per article (GBP, circa 2007)



Note: Includes the direct costs of writing, peer review, publishing and disseminating in e-only format, and excludes VAT. Self-archiving includes publisher production and review costs, including commercial margins (*i.e.* overlay services).

Source: EI-ASPM model: Authors' analysis.

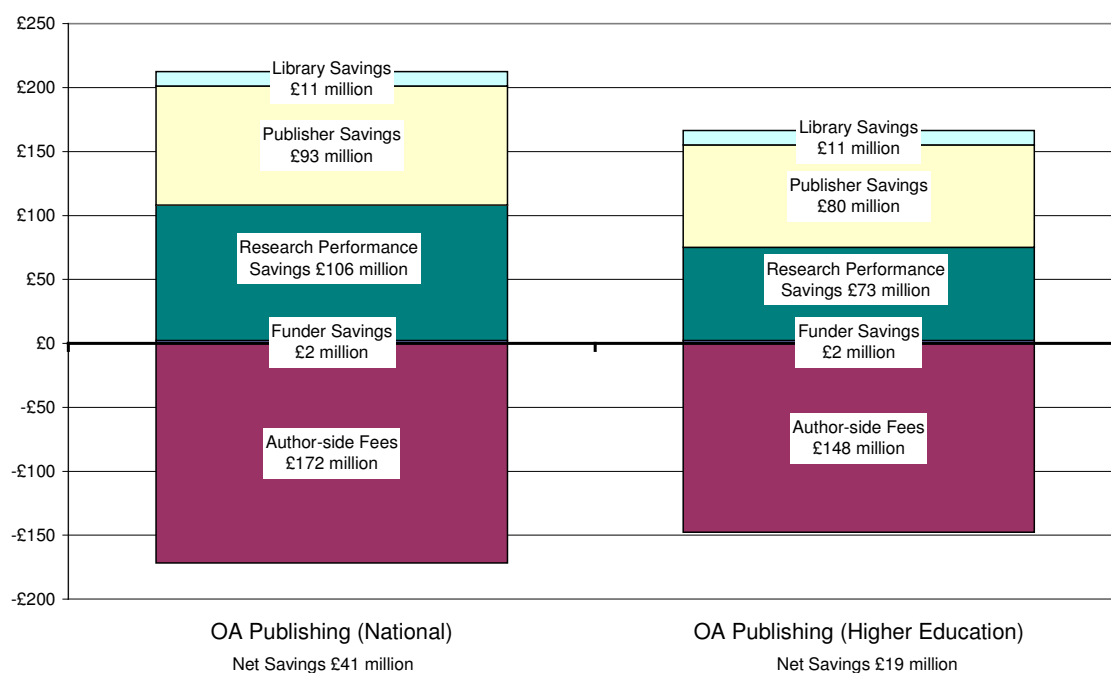
For UK higher education, these journal article cost differences would have amounted to savings of around £80 million per annum circa 2007 from a shift from subscription access to open access publishing, and £116 million from a shift from subscription access to open access self-archiving with overlay services. While alternative publishing models for scholarly books are much less developed and costings more speculative as a result, similar savings would appear to be available from shifting to open access book publishing.

In addition to direct cost differences, there are potential system cost savings. Based on the cases and scenarios explored in this study we estimate that ***open access publishing for journal articles might bring system savings of around £215 million per annum nationally in the UK (at 2007 prices and levels of publishing activity), of which around £165 million would accrue in higher education.*** The open access self-archiving with overlay services model explored in this study is necessarily speculative, but a repositories and overlay services model may well produce greater cost savings than open access publishing – with our estimates suggesting system savings of perhaps £260 million nationally, of which around £205 might accrue in higher education.

These savings can be set against the cost of open access publishing, which if all journal articles produced encountered author fees would have been around £170 million nationally in 2007, of which £150 million would have been faced by higher education institutions. Showing net savings from open access publishing of around £40 million nationally and £20 million in higher

education (Figure S-VI). Similarly, with estimated repository costs at around £22 million nationally and £18 million for higher education, the potential net savings might be around £200 million per annum.

Figure S-VI: Estimated annual costs and cost savings: OA publishing (GBP millions, 2007)



Note: Includes estimated e-only cost savings, and excludes acquisition costs (to avoid double counting). Research performance savings exclude the impacts of accessibility and efficiency on returns to R&D. National library handling cost savings are those relating to SCONUL libraries only and include handling of all library journal acquisitions.

Source: EI-ASPM model: Authors' analysis.

*Thus the cost savings alone are likely to be sufficient to pay for open access journal publishing or self-archiving, independent of any possible increase in returns to R&D that might arise from enhanced access. Thus, it seems possible that open access publishing alternatives could be supported from within existing budgetary allocations.*

Nevertheless, *the increase in returns to R&D resulting from enhanced access may be substantial.* To explore the impacts of enhanced access on returns to R&D we modify a basic Solow-Swan model, by introducing 'accessibility' and 'efficiency' as negative or friction variables, and then calculate the impact on returns to R&D of reducing the friction by increasing accessibility and efficiency (Section 5.1).

We find that with a 20% return to publicly funded R&D, for the major categories of research expenditure in the UK in 2006 a 5% increase in accessibility and efficiency would have been worth:

- £172 million per annum in increased returns to public sector R&D (*i.e.* government and higher education);
- £124 million per annum in increased returns to Higher Education R&D (HERD);
- £109 million per annum in increased returns to Government R&D (GovERD); and
- Around £33 million per annum in increased returns to research councils (RCUK) competitive grants funded R&D.

These are recurring annual gains from the effect of one year's R&D expenditure, so if the change that brings the increases in accessibility and efficiency is permanent they can be converted to growth rate effects.

## Comparing costs and benefits

Modelling the impacts of an increase in accessibility and efficiency resulting from more open access on returns to R&D over a 20 year period and then comparing costs and benefits, we find that the benefits of open access publishing models are likely to outweigh the costs.

First, we explore the cost-benefit implications of simply adding open access publishing and self-archiving to current activities, all other things remaining the same (*i.e.* ceteris paribus scenarios). Then we explore the implications of open access publishing and self-archiving as alternatives to current activities, by adding the estimated system savings to estimated returns (*i.e.* net cost scenarios) (Sections 6.1 and 6.2). Of course, the scenario adding open access publishing to current activities is 'unrealistic', as parallel publishing all articles in open access and subscription journals simultaneously would not be allowed under the copyright demands of subscription publishing.

Our cost-benefit comparisons suggest that the additional returns to R&D resulting from enhanced accessibility and efficiency alone would be sufficient to cover the costs of parallel open access self-archiving without subscription cancellations (*i.e.* Green OA). ***When estimated savings are added to generate net costs there is a substantial increase in the benefit/cost ratios***, and for both open access publishing and self-archiving (*i.e.* Gold OA and Green OA) the benefits exceed the costs, even in transition. Indicative modelling of post-transition 'steady-state' alternative systems suggests that, once established, alternative open access publishing and/or self-archiving systems would produce substantially greater net benefits.

For example, during a transitional period we estimate that the benefits from increased returns to R&D resulting from open access publishing all journal articles produced in UK higher education would be around 1.5 times the costs, and the benefits from open access self-archiving with overlay editorial and peer review services would be more than 14 times the costs. Indicative modelling of post-transition 'steady-state' alternative systems returns benefits of 5 times costs for open access publishing and more than 45 times the costs for open access self-archiving with overlay services (See Table S-V and Sections 5 and 6).



Table S-V: Summary of benefit/cost comparisons by scenario and model (GBP millions and benefit/cost ratio)

| <i>Scenario</i>   | <i>Costs</i> | <i>Savings</i> | <i>Benefits</i> | <i>Benefit/Cost Ratio</i> |
|---|--------------|----------------|-----------------|---------------------------|
| <b>Ceteris Paribus Scenarios</b>                            |              |                |                 |                           |
| <b><i>Transitional Model:</i></b>                           |              |                |                 |                           |
| OA Publishing in HE (unrealistic)                           | 1,787        | ..             | 615             | 0.3                       |
| OA Publishing Nationally (unrealistic)                      | 2,079        | ..             | 2,353           | 1.1                       |
| OA Repositories in HE                                       | 189          | ..             | 615             | 3.2                       |
| OA Repositories Nationally                                  | 237          | ..             | 2,353           | 9.9                       |
| <b><i>Simulated Steady State Model:</i></b>                 |              |                |                 |                           |
| OA Publishing in HE (unrealistic)                           | 1,787        | ..             | 6,876           | 3.8                       |
| OA Publishing Nationally (unrealistic)                      | 2,079        | ..             | 26,318          | 12.7                      |
| OA Repositories in HE                                       | 189          | ..             | 6,876           | 36.3                      |
| OA Repositories Nationally                                  | 237          | ..             | 26,318          | 110.8                     |
| <b>Net Cost Scenarios</b>                                   |              |                |                 |                           |
| <b><i>Transitional Model:</i></b>                           |              |                |                 |                           |
| OA Publishing in HE with direct and indirect savings        | 1,787        | 2,016          | 615             | 1.5                       |
| OA Repositories in HE with direct and indirect savings      | 189          | 2,148          | 615             | 14.6                      |
| OA Publishing Nationally with direct and indirect savings   | 2,079        | 2,575          | 2,353           | 2.4                       |
| OA Repositories Nationally with direct and indirect savings | 237          | 2,697          | 2,353           | 21.3                      |
| <b><i>Simulated Steady State Model:</i></b>                 |              |                |                 |                           |
| OA Publishing in HE with direct and indirect savings        | 1,787        | 2,016          | 6,876           | 5.0                       |
| OA Repositories in HE with direct and indirect savings      | 189          | 2,148          | 6,876           | 47.7                      |
| OA Publishing Nationally with direct and indirect savings   | 2,079        | 2,575          | 26,318          | 13.9                      |
| OA Repositories Nationally with direct and indirect savings | 237          | 2,697          | 26,318          | 122.2                     |

Note: Costs, savings and benefits are expressed in Net Present Value over 20 years, in GBP millions. See the modelling assumptions outlined in Section 5 and modelling results in Section 6.

Source: EI-ASPM model: Authors' analysis.

## Exploring topical issues

We also examine a number of topical issues, beginning with that of diverting research funds to author-side payments for open access publishing, and then exploring the possible impacts of delayed open access embargo periods and of speeding up the research and discovery process (*e.g.* through self-archiving *pre*-prints) (Section 6.3).

Our analysis suggests that under the rather conservative modelling assumptions, funding agencies or institutions might be able to divert up to 3.5% of research funding to author-side payments before net benefits were exhausted – a level that is much higher than is commonly reported and one-and-a-half times that required (on estimated costs). Of course, this is dependent on the returns characteristic for the field of research, and returns are typically higher in medical research than elsewhere and might be expected to be lower in some areas of Humanities and the Arts. Hence, the percentage of funds at which breakeven might be reached would likely be higher for the Medical Research Council or Wellcome Trust than for the Arts and Humanities Research Council, for example.

Simulating the impact of a one year ‘delayed open access’ embargo on all journal articles, we find that over 20 years such delays would reduce the estimated increase in returns to R&D by around 2% (in the transitional model) – costing the equivalent of around £120 million in lost returns to UK higher education research spending.

Simulating the impact of the potential for enhanced and/or earlier access to speed up the research and discovery process (*e.g.* through self-archiving *pre*-prints), we find that over 20 years speeding up the process by one year increases the estimated increase in returns to R&D by around 3.6% (in the transitional model) – worth around £220 million in additional returns to Higher Education R&D expenditure.

## Conclusions

The costs, benefits and impacts of alternative scholarly publishing models revealed in this study demonstrate that research and research communication are major activities and the costs involved are substantial. Preliminary analysis of the potential benefits of more open access to research findings suggests that returns to research can also be substantial, and that *different scholarly publishing models can make a material difference to the returns realised, as well as the costs faced.*

*It seems likely that more open access would have substantial net benefits in the longer term and, while net benefits may be lower during a transitional period they are likely to be positive for both open access publishing and self-archiving alternatives (i.e. Gold OA) and for parallel subscription publishing and self-archiving (i.e. Green OA).* This suggests that there are gains to be realised from moving towards open access publishing models and, despite the lag between the costs and the realisation of benefits, the transition may be affordable within existing system-wide budgetary allocations.

## Implications for scholarly communication in the UK

Open access publishing and self-archiving (with overlay services) appear to be more cost-effective systems for scholarly publishing, with cost savings available throughout the scholarly communication process – in funding, performing, publishing, disseminating and preserving research. However, a shift from a user-side to producer-side system for funding publishing implies a greater concentration of costs and diffusion of benefits, with costs concentrated among the most intensive producers of scholarly content and benefits diffused across many users. Nevertheless, the most intensive producers of scholarly content are also among its most intensive consumers, and the system cost savings available from open access publishing and self-archiving alternatives are likely to be realised most by the most intensive users, through, for example, reduced library acquisition and handling costs, research time and cost savings, and so on.

Many analysts have compared institutional library journal acquisition expenditure with likely institutional open access publishing fees, and for the more research intensive universities they have noted that the latter may exceed the former. But such comparisons overlook the implied

library handling cost savings from an alternative open access publishing system, which would be greatest in institutions with the most extensive research collections and active researcher use. The time and cost savings available in the performance, reporting and management of research would also be greatest in those institutions performing most research. Hence, a fuller accounting of costs, cost differences between the alternative publishing models, and potential cost savings is required than has hitherto been typical.

### *Implications for funders*

The operational costs of funding agencies are unlikely to change very much as a result of alternative publishing models, but there is likely to be an impact on the implied effective level of research funding – primarily through the diversion of research funding into author-side fees.

Noting that only around half of all open access journals actually charge author fees but that support for open access publishing would nevertheless be coming from the producer side, we estimate that had all UK authored journal articles been published in an entirely producer-pays open access publishing model in 2007 it would have cost around £170 million nationally in the UK, of which around £150 million would have been from higher education.

Balancing the negative impacts of such a diversion of research funding on the level of research activity against the positive impacts of enhanced accessibility and efficiency on returns to that R&D still conducted and system cost savings, *we find that funders can feel comfortable diverting the required level of research funding to producer-side publication payments*. That is to say that, at the estimated costs, the benefits of enhanced accessibility and efficiency and potential system cost savings outweigh the costs of diverting research funds to author-side open access publishing fees (Section 6.3.1).

### *Implications for researchers*

In addition to possible costs and cost savings, impacts on funding flows within research activities would be likely to revolve around possible differences in the use of researcher time and funding (*e.g.* in applying for and obtaining permissions versus self-archiving to a subject or institutional repository, etc.). Time and cost savings are likely to arise in such areas as: reduced search, discovery and access time through enhanced discoverability, greater accessibility and less use of authentication and access control and of proprietary silo access systems; and less time spent on seeking and obtaining permissions. In addition to these savings, there are opportunities for new forms of analysis when the findings and record of research are openly available, due to both their accessibility and usability (*e.g.* permission to use for any purpose, subject only to attribution). Independent scholars working outside mainstream institutions, as well as those from poorer institutions and poorer countries, could benefit enormously from open access to scholarly publications (Section 3.3.2).

Open access publishing may require author payments, and researchers in fields that are relatively poorly funded, those working without specific project funding, and independent *scholars may find it difficult to pay, unless there are specific funds made available to support publishing fees*. Self-archiving also takes some additional time, but the benefits from enhanced

accessibility, broader readership and, potentially, increased citation are likely to make the effort worthwhile.

### *Implications for research institutions*

From the perspective of universities and research institutions, research library acquisition and handling cost savings should also be factored in. Because research intensive institutions are both major producers and users of scholarly publications, research and library cost savings will offset additional producer-side costs. Nevertheless, ***research intensive institutions might pay relatively more in a producer-pays system, and it would be preferable to cover the direct costs of producer-side open access publishing fees from competitive and block grant funding.*** This might be scaled to outputs in the previous year, and would be likely to cost of the order of £75 million to £150 million per annum to publish UK higher education journal article output in open access journals. Similar support mechanisms could be offered for the operation of institutional repositories and, perhaps, open access book publishing.

Enabling and ***supporting self-archiving through the operation of institutional repositories offers a number of potential benefits for universities and research institutions,*** not only through providing greater support to research, but also in providing a platform for hosting and showcasing the institutions research and maintaining a more complete record of it, which can assist the institution in research management and reporting functions. There are also potential benefits in hosting teaching and learning materials alongside research materials in integrated institutional repositories (Section 3.3).

### *Implications for publishers and the publishing industry*

Savings relating to publishing are captured in the publisher cost differences between the publishing models. ***Clearly, reduced costs would result in reduced revenue flows from research users to publishers, although these reductions may well be offset by revenue gains from selling value-adding services to a larger number of readers and/or authors and from alternative revenue streams.***

There are taxation differences between alternative publishing models, as well as what are more significant differences between formats (e.g. VAT on electronic content but not on the same content in print form). Obviously, with no access charges levied in open access models there would be no VAT collected on subscriptions. However, VAT would be collected on the (domestic) provision of publisher services, including author-pays fees and fees for overlay services, depending on the domicile of content producers and the VAT registration status of institutions. Consequently, ***while one might expect lower publisher production costs to imply somewhat lower taxation revenue in open access publishing and self-archiving models, the net impact is unlikely to be significant and will depend on the methods of payment and level of international publishing*** (e.g. whether or not authors publish with domestic or overseas publishers).

A reduction of revenue to the publishing industry, should it arise, would imply a reduction of activity and employment in the industry. Such adjustments are difficult for those concerned, but

an economy is a dynamic system and, over the business cycle, is likely to achieve something close to ‘full employment’. As a result, the capital and labour no longer employed in publishing would be employed in an alternative activity. *Given the relative size of the publishing industry and the rate at which alternative publishing models are being adopted, it is unlikely that the UK economy would have difficulty adjusting to such a change.*

The publishing industry in the UK is a major exporter, contributing as all exporters do to the balance of payments. However, scholarly publishing is a global activity with payments for scholarly content and services flowing both in and out. While it is impossible to predict how alternative publishing models would affect these payment flows, there is no obvious reason to expect the net effect to be large. For example, *possible losses from reduced subscription payments inflows to the UK would be offset by reduced subscriptions payments outflows and increased author-pays fees and overlay services payments inflows to UK-based open access publishers.* The impacts of a possible marginal reduction in publishing industry revenues and employment on the balance of payments would depend on whether the alternative application of the capital and labour was more or less export or import oriented. That is impossible to know, but there is no obvious reason to expect the net effect to be significant.

### *Implications for research libraries*

*Savings relating to facilitating dissemination, retrieval and preservation are largely captured in the research library acquisition and handling cost differences between the publishing models.* There are also library-related savings in such areas as operating and supporting access and authentication systems, permissions and copyright fees, etc.

It is difficult to say exactly how open access publications will be treated by research libraries and what role libraries would play in dissemination and preservation in these alternative publishing models. Nevertheless, we suggest that *research libraries may continue to play a key role in providing access to open access journals* and have costed library handling activities accordingly. With little evidence to date that open access self-archiving leads to subscription cancellations, acquisition cost savings have not been included. However, should they arise in the future, there would be potential for significant additional savings.

### *Implications for government and central agencies*

There is likely to be uncertainty during the coming years as to the direction and speed of a transition towards more open access to research findings through open access publishing and/or self-archiving, and there will be difficulties in shifting budgetary allocations around the system in such a context. Moreover, *some of the savings and benefits resulting from alternative publishing models cannot be realised until some time after the costs have been met. Consequently, it seems inevitable that central allocations will be required at the funder, institutional and, perhaps, national levels.*

Estimated annual author-pays costs of around £170 million for the UK nationally (£150 million for higher education) and perhaps £23 million nationally (£18 million for higher education) for a basic system of publications-oriented institutional repositories are relatively modest in

comparison to UK gross expenditure on R&D of around £24,000 million per annum and higher education R&D expenditure of £6,000 million per annum. All the more so when system-wide cost savings as well as potential increases in the social returns to R&D resulting from more open access to research findings are likely to outweigh those costs.

## Recommendations

Our analysis suggests that there is evidence to support a move towards more open access to research findings, and it provides some guidance as to where the gains may be most substantial, the potential levels of cost and cost savings involved, and the budgetary implications for various actors in the system.

### *Overcoming the barriers*

Given the potential benefits, *there is scope to focus on reducing the barriers to transitioning to more cost-effective scholarly publishing models*. Key areas for attention are those of enabling innovation and aligning incentive and reward systems to create a level playing field, and raising awareness of the opportunities. This might involve:

- *Ensuring that research evaluation is not a barrier to innovation* (e.g. by developing and using metrics that support innovation in scholarly publishing, rather than relying on traditional evaluation metrics that reinforce and reward traditional publishing models and behaviours);
- *Ensuring that there is funding for author or producer side fees* (e.g. encouraging all research funders to make explicit provision for publication charges, and encouraging higher education and research institutions to establish funds to support publishing fees);
- *Encouraging and funding the further development of institutional and/or subject repositories* to enable author self-archiving; and
- *Supporting advocacy initiatives* to inform and educate funders, researchers and research managers about the potential impacts of alternative publishing models.

### *Realising the benefits*

Cost savings can be realised more quickly than can increases in returns to R&D, so there is merit in making them an early focus. This might involve:

- *Focusing on areas where there are activity cost impacts* relating to the various publishing models (e.g. complexity and uncertainty in such areas as copyright and licensing conditions and permissions, purchasing and licensing negotiations, and the cost impacts of imposing access control and authentication systems); and
- *Focusing on areas where there are system cost impacts* relating to the various publishing models, especially where they are likely to be substantial (e.g. the implications of alternative publishing models for research costs, publishing costs,



research library handling and acquisitions costs, and research reporting and management costs).

### Box S-I: Areas for further research

There are many areas in which more information and analysis might give stakeholders greater confidence to experiment with alternative publishing models. This might involve:

- ***Encouraging and supporting the collection of better data*** in such areas as: open access repository costs, impacts and operational statistics; operational information about special libraries and library related activities outside higher education; and information on the activities of users of scholarly publications in industry, government and non-government organisations and the community at large;
- ***Supporting or conducting more research into areas where the greatest benefits may be available*** (e.g. the possibilities for, and potential benefits of, convergence and the integration of more open access to publications, data curation and sharing, and education and learning that is possible through repositories);
- ***Supporting or conducting more research into alternative and emerging forms of scholarly communication***, in order to better understand their roles and interactions between them, and the systemic implications of alternative publishing models and new forms of research communication in what is a rapidly changing environment; and
- ***Encouraging greater integration of research relating to the conduct of R&D and operation of the S&T system with research on scholarly publishing and scholarly communication more broadly*** (e.g. research relating to Open Innovation).

Source: Authors' analysis.

Our analysis suggests that open access self-archiving, either in parallel with subscription publishing or with overlay services, may be more cost-effective, although more information is required on repository costs and the potential benefits of greater integration of publications with other forms of research output, their integration into learning materials, and the curation and sharing of research data (Box S-I). Hence, ***there is scope to focus greater attention on the development of repositories***. This might include:

- ***Encouraging and supporting the development of institutional and/or subject repositories***;
- ***Encouraging greater focus on the operational effectiveness of repositories*** (e.g. enhancing metadata standards and quality, effective federation, enhanced discoverability and searchability, and, perhaps most importantly, supporting the development and use of metrics and reporting suitable for research evaluation, etc.); and
- ***Encouraging greater sharing of information and experiences*** to enable stakeholders to better understand the costs and benefits involved and build more effective 'business cases' for repositories.



Our analysis also suggests that *there may be considerable benefits available from a shift to open access scholarly book publishing*. Hence, there is scope to further explore the possibilities. This might involve:

- *Supporting or conducting more research into the academic book publishing value chain*, where substantial costs savings and benefits appear to be available from shifts to electronic and open access publishing, but alternative publishing models are as yet more embryonic and relatively little is known about the longer term operational viability of open access scholarly book publishing; and
- *Encouraging greater sharing of information and experiences* of emerging open access book publishing initiatives to enable stakeholders to better understand the costs and benefits involved and build more effective ‘business cases’.

### *Sharing the gains*

While a major contributor to the scholarly literature, the UK accounts for no more than 10% of the World’s scientific papers. Hence, *international developments are of great importance in realising the benefits of more open access* and much can be achieved by international efforts towards sharing the gains. This might involve:

- *Encouraging and supporting greater attention to the potential benefits of more open access to research findings in international fora* (e.g. European Commission, OECD, UNESCO, etc.); and
- *Encouraging international cooperation between agencies and supporting the activities of such cooperative efforts*.

\*\*\*\*\*

# 1 Introduction

A knowledge economy has been defined as: “...one in which the generation and exploitation of knowledge has come to play the predominant part in the creation of wealth. It is not simply about pushing back the frontiers of knowledge; it is also about the more effective use and exploitation of all types of knowledge in all manner of economic activities” (DTI 1998). In a knowledge economy, innovation and the capacity of the system to create *and* disseminate the latest scientific and technical information are important determinants of prosperity (David and Foray 1995; OECD 1997). Scholarly publishing plays a key role, as it is central to the efficiency of research and to the dissemination of research findings and diffusion of scientific and technical knowledge. However, advances in information and communication technologies are disrupting traditional models of scholarly publishing, radically changing our capacity to reproduce, distribute, control, and publish information. One key question is whether there are new opportunities and new models for scholarly publishing that would better serve researchers and better communicate and disseminate research findings (OECD 2005, p14).

Debate on the economics of scholarly publishing and alternative publishing models focuses almost entirely on costs, but from an economic perspective the aim is to have the most cost-effective system, not (necessarily) the cheapest. And however much one studies costs, one cannot know which is the most cost-effective system until one examines both the costs *and* the benefits. Hence, the aim of this project was to examine costs *and* benefits, and in so doing to inform policy discussion and help stakeholders understand the institutional, budgetary and wider economic implications of three of the major emerging models for scholarly publishing (*i.e.* subscription publishing, open access publishing and self-archiving). It seeks to build on and extend recent work on the costs and benefits associated with alternative scholarly communication models (Houghton *et al.* 2006) and respond to some of the gaps and challenges identified in the *UK Scholarly Journals Baseline Report* (EPS *et al.* 2006).

The project involved two major phases:

- *Phase I: Identification of costs and benefits* – sought to describe the three models of scholarly publishing, identify all the dimensions of cost and benefit for each of these models, and examine which of the main players in the scholarly communication system would be affected, and how they might be affected, by each of the costs and benefits identified; and
- *Phase II: Quantification of costs and benefits* – sought, where possible, to quantify the costs and benefits identified in Phase I; identify, and where possible quantify, the cost and benefit implications for each of the main players in the scholarly communication system; and, where possible, compare the costs and benefits of the three models for the main players in the scholarly communication system.

While wide-ranging in scope, an important focus of the work was the implication of the three models for UK higher education and for journal and scholarly monograph publishing.

## 1.1 Approach to the study

The UK ‘*Baseline Report*’ concluded that “[the] general paucity of sources means that most data are indicative rather than conclusive, and that establishing evidence-based causal relationships in key areas cannot currently be demonstrated. Similarly, extrapolation from restricted samples to wider communities is currently not possible. That there is little by way of solid data to analyse or validate is, therefore, a key finding of this study.” (EPS *et al.* 2006, p94).

Nevertheless, it is important to try to move forward. In this study, we seek to do so by means of a step-wise progression and triangulation, involving:

- Collecting, collating and synthesising the most recent and best available evidence;
- Gathering new data and consulting on both new sources relating to the identified information gaps *and* information necessary to inform estimations; and
- Where gaps remain, developing robust estimates based on sound and transparent methods.

### 1.1.1 Phase I: *Identification of costs and benefits*

The literature relating to the costs of scholarly publishing reveals two distinct approaches. The majority of writers focus narrowly on the publishing process and discuss the functions and costs involved. Others explore a broader context, seeing publishing as a part of a wider system of knowledge creation and dissemination. However detailed, analyses that focus on publishing activities alone are unlikely to reflect the system-wide costs or benefits involved, and risk mistaking cost shifting for cost saving. Consequently, a systems perspective is adopted for this study.

### Description of the models

The description of the three major emerging models of scholarly publishing (*i.e.* subscription publishing, open access publishing and self-archiving) builds on existing descriptions to provide a foundation for analysis. That analysis includes both a general overview highlighting the key characteristics of each model, and a detailed description of the activities along the scholarly communication value chain highlighting where the three models differ. To that end we have developed and extended the Scholarly Communication Life-Cycle Model originally proposed by Bo-Christer Björk (2007).

### Identification of costs

A detailed description of the scholarly communication system provides the foundation for the identification of the costs involved in each step along the scholarly communication value chain. In view of the multi-dimensional nature of scholarly communication, we adopt a matrix approach to the identification of the costs and benefits, with the aim being to produce a “matrix of costs” by:

- Activities (*e.g.* writing, peer review, publishing, search and discovery, reading, etc.);

- Actors (*e.g.* universities, scholarly content creators and users in industry, government and non-government organisations, and the community, publishers and intermediaries, etc.);
- Objects (*e.g.* journals, articles, research monographs, datasets, etc.);
- Functions (*e.g.* registration, certification, dissemination, preservation, etc.); and
- Other non-communication applications (*e.g.* research evaluation).

The work in Phase I involved a literature review focusing on the very extensive discussion of scholarly communication costs and, more narrowly, publishing and publisher costs, supplemented by further desk-based analysis and consultation. That analysis has been informed by the extended Scholarly Communication Life-Cycle Model, developed in collaboration with Bo-Christer Björk using the IDEF0 Activity Modelling Method. The modelling software used for this project supports both detailed description and analysis of processes and integrated activity costing (NIST 1993; Erraguntla and Benjamin 2007).

## Identification of benefits

The identification of benefits builds on the “impacts framework” suggested by Houghton *et al.* (2006), which was itself based on a wide-ranging literature review. Using this as a starting point, a literature review focusing on discussion of existing and potential impacts of subscription or toll access publishing (including the Big Deal) and of OA publishing and self-archiving provides the basis for analysis. Self-evidently, there are overlaps between the costs and benefits, with the benefits of one model and/or for one actor in the system often being costs for others (*e.g.* lost citations, lost impact and lost opportunities for new research methods could be considered to be among the costs of toll access and/or the benefits of open access). Inevitably, this leads to some repetition during the discussion of costs and benefits.

### 1.1.2 Phase II: Quantification of costs and benefits

As many of the activities and related costs and benefits are common across the three models for scholarly publishing, the key focus is on where the three models differ. The purpose of Phase II quantification is to understand if the oft cited costs and benefits of more open access are real and, if so, how material they might be.

## Quantification of costs

Many aspects of scholarly communication take place in a non-commercial or non-market environment, or in environments that are less than fully commercial. Consequently, transactions (payments) are a poor guide to costs in many areas. However, many of the core activities of scholarly communication involve people’s time (*e.g.* reading, writing, peer review, etc.). In these areas, an activity-based approach to costing is useful (*i.e.* an approach that focuses on measuring the time involved and costing that time in terms of salary and on-costs, together with the overhead costs typical in the context of the activity). Such an approach can provide a foundation for estimating costs for activities (*e.g.* peer review) and, because they are bundles of

activities it can also provide a foundation for estimating the cost of objects (*e.g.* a journal article), and the cost of producing those objects in collective or individual institutional contexts (*e.g.* the cost of writing journal articles in UK higher education institutions).<sup>6</sup> Activity costing outside higher education is more difficult due to the wider variation of overhead costs and relatively poor centralised data collection, but the more commercial orientation of many non-university contexts allows the supplemental use of market-based costing.

There is a very extensive literature on the costs of journal publishing, in particular, and scholarly publishing more generally. The quantification of costs undertaken herein builds on the literature review undertaken to identify costs (Phase I). This is supplemented by further original data collection and consultation about both costs and the information required to support estimations. Desk-based work has focused on developing a ‘consensus cost model’ from these sources using the matrix approach to costing outlined in Phase I and structured to match the scholarly communication process model developed in Phase I.<sup>7</sup>

### Quantification of benefits

The quantification of benefits builds on the literature review undertaken to identify benefits by:

- Developing a ‘consensus model’ of benefits from the data and/or estimates reported in the literature;
- Attempting to quantify benefits relating to cost savings and cost shifting based on the quantification of those costs (above); and
- Estimating benefits associated with efficiency gains (*e.g.* enhanced discoverability and speed of access, etc.).

Again, the primary focus is on differences between the three models, with particular reference to UK higher education.

### Comparing costs and benefits

Benefit/cost comparisons can be simple when the object is easily defined, but tend to become more difficult when there is a range of objects and dimensions to be compared and comparisons can be done at different levels of aggregation. One key is to compare genuine alternatives. This can be done by activity (*e.g.* the relative cost-benefit of each model for peer review), item (*e.g.* the relative cost-benefit of each model for an article), and/or player (*e.g.* the relative cost-benefit of each model for UK universities). Various scenarios are explored.

---

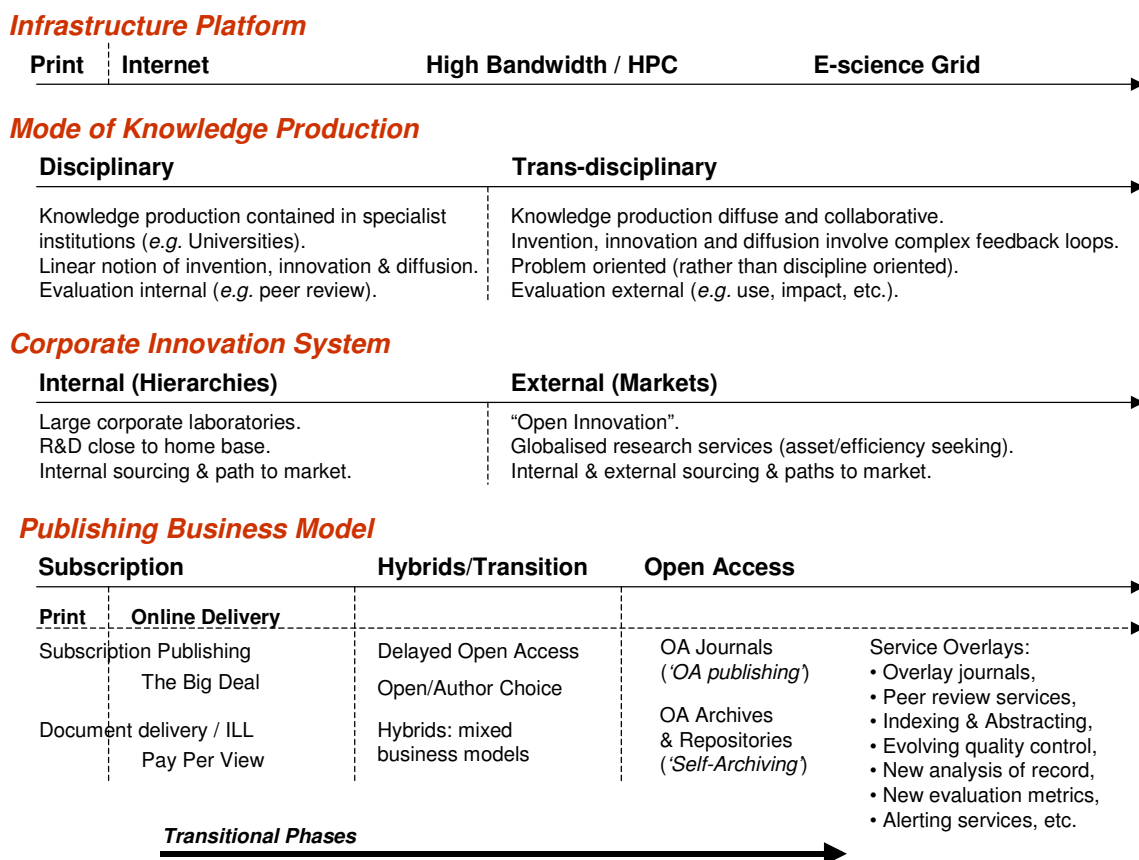
<sup>6</sup> Such an approach to activity costing is consistent with and can build on the Transparent Approach to Costing (TRAC) and Full Economic Costing (fEC) used in higher education in the UK. See <http://www.jcpsg.ac.uk/guidance/index.htm>

<sup>7</sup> All costs are expressed in 2007 UK pounds and, where necessary, have been converted to pounds using OECD published annual average exchange rates and adjusted to 2007 using the UK consumer price index published by the National Statistical Office.

## 1.2 Emerging models for scholarly publishing

We have inherited system of scholarly publishing that evolved over many years, primarily to serve the needs of disciplinary research in specialist institutions in a print-based environment. But, the scholarly information environment is undergoing profound change. New technologies and new means of research communication and dissemination are changing traditional publishing and enabling an increasing range of non-traditional forms of communication (*e.g.* lists, blogs, wikis, etc.). At the same time, research practices are changing, with more

Figure 1.1: The evolution of scholarly communication



Source: Derived from Houghton, J.W. (2007) 'Research Communication in Australia: Emerging Opportunities and Benefits,' Paper present at The National Scholarly Communications Forum 2007: Improving Access to Australian Publicly Funded Research – Advancing Knowledge and the Knowledge Economy, Canberra, July 16, 2007.

problem oriented, multidisciplinary research being conducted in a wider range of settings, and greater use of a wider range of digital objects from images to large data collections (Gibbons *et al.* 1994; Etkowitz and Leydesdorff 1997; Hey and Trefethen 2003). There is increased focus on research performance, evaluation and the application and commercialisation of findings, and users of research in industry and elsewhere are placing new demands on the system for access

and participation (Chesbrough 2003; Chesbrough *et al.* 2006). As a result, there are complex relationships between the infrastructure and online access, changing research practices, external research user needs, and evolving scholarly publishing business models (Figure 1.1).

### 1.2.1 Alternative publishing models

This study focuses on three emerging models for scholarly publishing, namely: subscription publishing, open access publishing and self-archiving (which, of itself, does not constitute formal publication). The primary focus is on online delivery, although print costs are considered.

These three models are not necessarily alternatives. For example, self-archiving may depend on subscription publishing for peer review, and open access publishing does not prevent self-archiving (*e.g.* of pre-prints). There are also a number of variations, hybrids and alternatives (*e.g.* delayed open access, open choice/author choice, etc.). Moreover, in practice, the three models co-exist in various mixes in different fields of research. Nevertheless, these three models do have some key defining characteristics, and these characteristics have cost implications for producers, intermediaries and the users and consumers of content, as well as implications for the flow of funds between them and the benefits each receives. They also have implications for the efficiency of research, the accessibility of research findings and their impacts, and, thereby, for returns to investment in R&D.

#### Subscription publishing

Subscription publishing refers to journal (and database) publishing and includes individual subscriptions and the, so called, Big Deal – where institutional subscribers pay for access to online aggregations (*e.g.* of journal titles) through consortial or site licensing arrangements. In a wider sense, subscription publishing includes any publishing business model that imposes reader access tolls and restrictions on use designed to maintain publisher control over that access in order to enable the collection of those tolls.

The subscription publishing model arose in the print era and reflects “print economics” (Cockerill 2006) wherein marginal cost is dependent on printing and distribution. Online access reduces marginal costs to near zero, which encourages bundling from the producers’ side: the more so where advertising and marketing costs can be significantly reduced by aggregating consumers. Some analysts have extended the logic of bundling beyond the content itself to subscription (*i.e.* bundling over time) and consortial or site licensing (*i.e.* bundling users) (Bakos and Brynjolfsson 1999; Bakos, Brynjolfsson and Lichtman 1999; Bakos and Brynjolfsson 2000). The ‘Big Deal’ subscription model is, therefore, a highly developed form of bundling (OECD 2005).

Publishers have developed online access systems to provide users with discovery capabilities and access to their journals online (and, increasingly, their e-book collections). While these are sometimes sophisticated and have involved considerable development expenditure, and some cross-platform searching is now possible, they tend to keep users within a particular publisher’s



portfolio of titles and their proprietary access system, and that they are proprietary systems imposes some cost on users as each operates differently.

**Key characteristics of toll access or subscription publishing:**

- Primary focus of coverage is scholarly journals and journal articles;
- Quality control, with much of the content being peer reviewed prior to publication;
- Reader access requires a toll payment by the reader or an intermediary (*e.g.* research library);
- Authors do not typically pay for publication, although in some areas it is quite common for publishers to levy page or plate charges;
- Publisher intellectual property requirements and/or licensing conditions set limitations on access to and use of the content; and
- Online access to a particular publisher's titles is typically provided through proprietary access systems and/or access restricted websites.

Big Deal licensing conditions and prices vary considerably, not only to titles and packages, but also between individual customers. Consortia typically achieve lower access prices, but face additional coordination and negotiation costs. Conversely, publishers reduce their marketing and negotiation costs by selling to consortia (*i.e.* bundling subscribers), although technical and support costs are typically greater and the skills required in marketing higher.

## Open Access

Definitions of Open Access vary, with major statements, such as The Budapest Open Access Initiative, The Bethesda Statement and The Berlin Declaration, developing the core concepts over time. Referring to these collectively as the 'BBB' definition, Peter Suber has suggested that open access removes price barriers (*e.g.* subscription fees) and permission barriers (*e.g.* copyright and licensing restrictions) to royalty-free literature (*i.e.* scholarly works created for free by authors), making them available with minimal use restrictions (*e.g.* author attribution). The key characteristics being free online access and minimal use restrictions.

Bailey (2006) noted several key points. First, open access works are freely available. Second, they are online, which would typically mean that they are digital documents available on the Internet. Third, they are scholarly works – romance novels, popular magazines, self-help books, and the like are excluded. Fourth, the authors of these works are not paid for their efforts [perhaps, more accurately, not paid for the content]. Fifth, since most (but not all) authors of peer-reviewed journal articles are not paid and such works are scholarly, these articles are identified as the primary type of open access material. Sixth, there are an extraordinary number of permitted uses for open access materials. Aside from the requirements of proper attribution of the author and the assurance of the integrity of the work, users can copy and distribute open access works without constraint. Seventh, there are two key open access strategies: open access journals and self-archiving.



### *Open Access publishing*

Open Access publishing (OA publishing) refers to journal publishing and includes situations where authors, their employing or funding organizations or other supporters contribute to the costs of publication in open access journals in the form of submission and/or publication payments (*i.e.* ‘author-pays’), and/or sponsor and support the operation of journals that are free to both readers and authors (*i.e.* do not charge ‘author fees’).<sup>8</sup> OA book publishing is also emerging as a model for the publication of scholarly monographs.

#### **Key characteristics of OA publishing:**

- Focus of coverage is primarily scholarly journals and journal articles, although OA book publishing is also emerging;
- Quality control, with much of the content being peer reviewed prior to publication;
- Toll-free reader access to the online version of journal articles or books to anyone with Internet access;
- Authors, their funders or supporting institutions may be required to pay publication fees (*e.g.* in the ‘author-pays’ model), although often they are not; and
- Less restrictive conditions are placed on use, although practices vary depending on publisher choice – with some publishers demanding copyright while others adopt more flexible licensing alternatives (*e.g.* creative commons or similar licensing).

OA publishing may operate in a range of pure or mixed forms. A key distinction is that between OA journals that impose publication charges (*i.e.* ‘author-pays’) and those that do not. In 2004, Regazzi (2004) estimated that 55% of OA journals relied on public funding support, 28% on print subscription revenues and 17% on author-pays revenue. More recently, it has been reported that “most full open access journals (52%) do not in fact charge any sort of author-side fees” – where ‘full open access’ referred to journals that provided immediate free access to all content online (Kaufman-Wills 2005, p10). Revenue models include grants, author charges, library or institutional membership fees, advertising, supplemental products (*e.g.* print copies) and other forms of industry support.<sup>9</sup> A substantial proportion of OA journals do not have a revenue model as such, but operate on an in-kind basis as ‘open source’ style projects where the institutions of the participating researchers accept that they use time and server space for the activity. However, there is no necessary link between OA publishing and non-profit publishing as there are both commercial OA publishers (*e.g.* BioMed Central and Hindawi) and non-profit OA publishers (*e.g.* Public Library of Science).

There are also a number of hybrids, such as:

- Delayed open access (*i.e.* where journals allow open access after a period during which articles are accessible to subscribers only);

---

<sup>8</sup> While OA publishing is typically electronic, it can be print or dual-mode.

<sup>9</sup> A notable feature of the library or institutional membership option is that it provides a mechanism for the transfer of subscription budgets to author fees within existing institutional budgetary structures.

- Open choice / author choice (*i.e.* where authors can choose to pay author fees and make their works open access, or not to pay and make their works subscription only); and
- Online open access (*i.e.* where journals allow free access to the online edition, while charging subscription fees for the print edition).

Willinsky (2007) also mentioned ‘development open access’ (*i.e.* where journals provide free access for organisations and/or individuals in developing countries), and refers to subscription journal publishers that allow self-archiving as ‘archival open access’.

**Table 1.1: Typology of open access journal models**

|                          |   |
|--------------------------|---|
| Archival OA<br>(‘Green’) | Permit authors to archive pre- and/or post-print in institutional repository or own website |
| Delayed OA               | Provide free access 6-12 months after subscriber access to print/online edition             |
| Online OA                | Provide free access to online edition, with subscription retained for print edition         |
| Development OA           | Provide free access to institutions and individuals in developing nations                   |
| Hybrid OA                | Enable authors or institutions to purchase open access for specific articles                |
| Complete OA<br>(‘Gold’)  | Offer immediate access without restrictions, using article fees and grants                  |

Source: Willinsky, J. (2007) *Ensuring a Journal’s Economic Sustainability While Increasing Access to Knowledge*, Public Knowledge Project, Simon Fraser University, Vancouver.

The key characteristics of such models relate to the speed of access and delay imposed, uncertainty as to access for readers due to the mix of open and closed material, the variety of practices regarding imposition of copyright and use limitations versus the adoption of creative commons or similar licensing, and placement of the material in proprietary publishers’ access systems used for subscription publishing. As a result, many of these hybrid and transitional models cannot be considered to meet widely accepted definitions of open access (*i.e.* available free, immediately and with minimally restrictions on use).

### *Self-archiving*

Self-archiving (OA self-archiving) refers to the situation where authors deposit their work in OA institutional repositories and/or subject repositories (it may also refer to making material available on personal and/or institutional websites and other forms of free online communication, such as listservs, blogs and wikis). OA repositories are typically:

- Subject or discipline based, offering open and free access to pre-print and/or post-print papers in a particular discipline or subject area; or
- Institutionally based, offering the same level of open and free access to the work and outputs of particular institutions (*e.g.* a university or research institute).

Institutional repositories may also perform other related knowledge management functions within the institution (*e.g.* holding collections for research management and reporting, open

courseware and course-packs, etc.). Subject repositories tend to focus more on pre- and post-prints and work that has been subjected to editorial and/or peer review, while institutional repositories are more varied in the content and levels of review (Terry 2006).

#### **Key characteristics of OA self-archiving:**

- A wider range of outputs can be accommodated than journals and journal articles alone;
- Limited quality control, with a mix of peer reviewed and non-peer reviewed content (*e.g.* pre- and post-prints), although some editorial oversight of postings is common;
- Toll-free access for authors *and* readers;
- Authors may grant greater freedom of use (*e.g.* creative commons or similar licensing), although practices vary considerably; and
- Enhanced discoverability, with subject and institutional repositories providing metadata and adopting standards that ensure the material is discoverable through general purpose web searchers as well as specialised searchers (*e.g.* OAI-PMH).

Material deposited in such repositories may include journal articles prepared for and/or submitted for publication (*i.e.* pre-prints), articles that have been accepted for publication and/or published (*i.e.* post-prints), and/or a range of other research outputs, such as working papers, pre- or post-print book chapters or entire books, project reports, field or laboratory reports, and a range of research-related non-text digital objects, such as sound or image files, data collections, models, software, etc. as well as theses and dissertations, course material and learning objects. However, of itself, self-archiving does not constitute formal publication, except when it is formal publications that are self-archived (*e.g.* post-print journal articles, book chapters and books, etc.).<sup>10</sup>

Funding organisations and institutions are increasingly introducing open access ‘mandates’ requesting or requiring the deposit (*i.e.* self-archiving) of all published articles (and, sometimes, data and other works) from their supported research in suitable open access repositories, either immediately or within a set period (typically of 6-12 months) (*e.g.* NIH, Wellcome Trust, CNRS, RCUK, Max Planck, etc.). Some also provide funding for ‘author-pays’ or other publication fees from their research and/or library funding (Rightscom 2007).<sup>11</sup>

Self-archiving can take a number of forms, running in parallel with other forms of formal publishing or, possibly, in time, operating as an alternative. For example:

- On the, so called, *green road* to open access, self-archiving involves the deposit (typically by the author) of the final author’s copy or final publisher’s copy of a work, depending on publisher permissions, following its acceptance for publication – with OA repositories and existing journals operating as complementary parts of an evolving

<sup>10</sup> Self-archiving other materials is a mechanism for the communication and the dissemination of informally-published and unpublished works.

<sup>11</sup> See the timeline of worldwide developments at <http://www.earlham.edu/~peters/fof/timeline.htm> and roadmap of mandate policies at <http://www.eprints.org/openaccess/policysignup/>.

system wherein repositories provide registration, awareness, access and archiving, while journals provide certification through peer review and often parallel the other functions;

- On the *gold road*, self-archiving involves the deposit (typically by the publisher) of a copy of the work as it appears in an OA journal – with the Internet, OA repositories and OA journals operating as complementary parts of an evolving system wherein OA journals provide certification through peer review and often parallel the other functions through their websites, while repositories provide registration, awareness, access and archiving (Prosser 2005); and
- In its *deconstructed* or *overlay* form, self-archiving provides the foundation for overlay journals and services (*e.g.* peer review, branding and quality control services), which depend on OA repositories to provide registration, awareness, access and archiving, while adding value to their content through quality control – but *not* paralleling the other functions (Smith 1999; Van de Sompel *et al.* 2004; Smith 2005; Simboli 2005; Houghton 2005b).

Peter Suber noted that a key difference between OA publishing and self-archiving is that OA journals conduct peer review while OA archives do not (Suber 2007a). However, both institutional and subject repositories can and often do exercise some form of editorial control and oversight (*e.g.* the contents of arXiv conform to Cornell University’s academic standards), and they may limit coverage to peer reviewed materials.

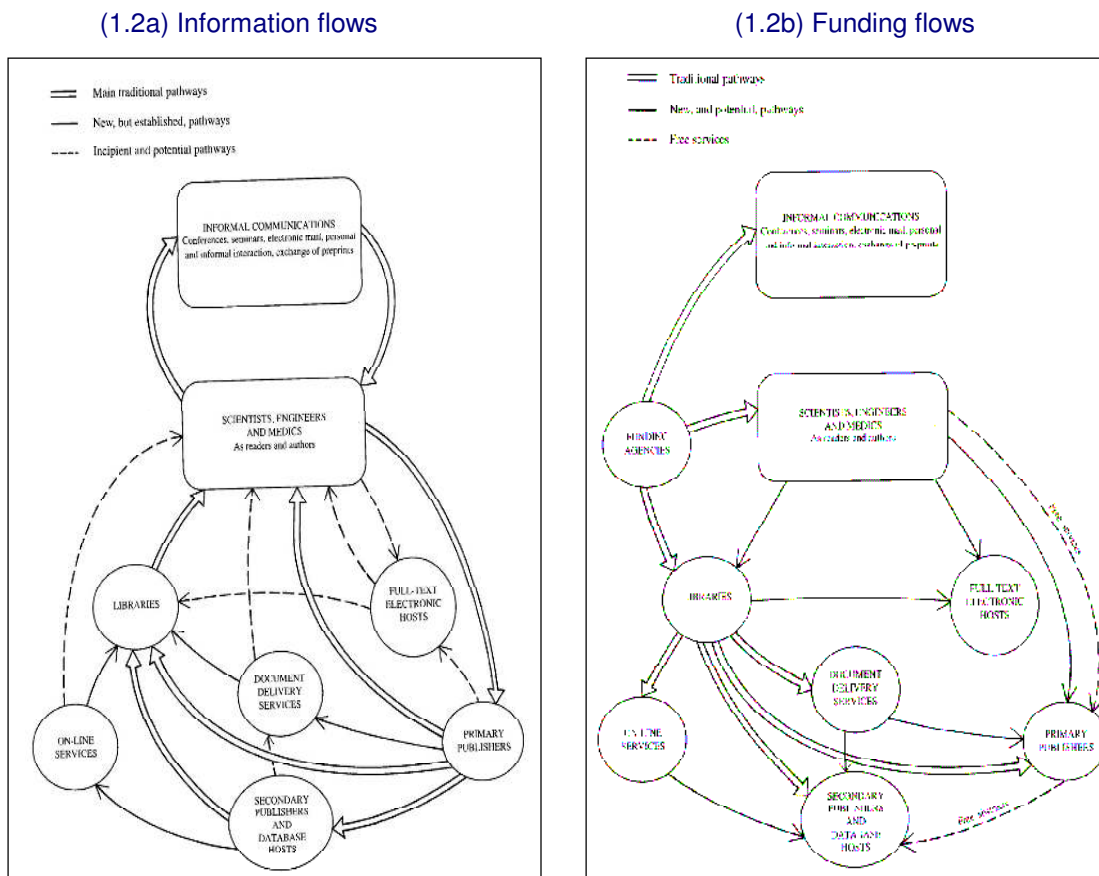
## 1.3 The scholarly communication process

In order to understand the implications of alternative scholarly publishing models for various participants in the system, it is necessary to examine the scholarly communication process in some detail. Many authors have addressed aspects of scientific or scholarly publishing, identifying elements of the value chain and processes involved. Characteristically, analysis focuses on the activities involved, the actors, agents, participants or stakeholders, and key functions. This section explores some of the system and process descriptions that have been put forward, and introduces the scholarly communication process model that we have adopted, extended and developed for this study.

### 1.3.1 Descriptions of the scholarly communication process

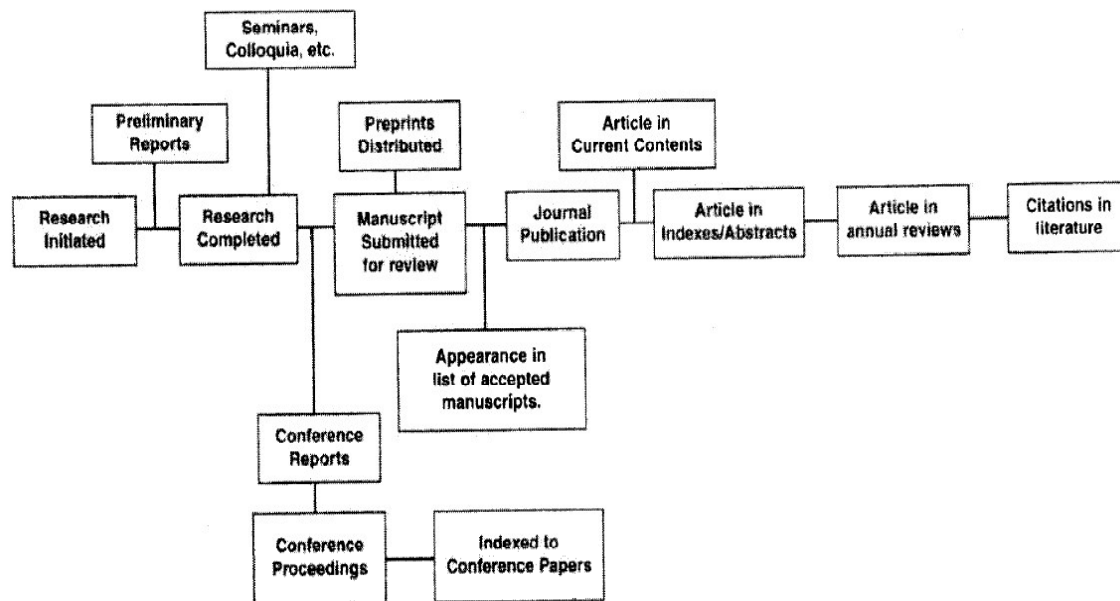
Coles *et al.* (1993) examined the STM information system in the UK, presenting schematic models of the information and funding flows characterising the system at that time. The principal actors identified were the scientists, engineers and medics, primary publishers, secondary publishers and database hosts, and libraries, with document delivery and online services and full-text electronic hosts entering the picture around that time. A range of informal communications were also noted (Figure 1.2a). Primary funding flows were identified as those coming from funding agencies and flowing to libraries, and thence to publishers, hosts and delivery services. The lack of a traditional flow of funds from readers and authors directly to publishers was also noted, as was the emergence of new funding flows of that type (Figure 1.2b).

Figure 1.2: Pathways of information and funding flows



Source: Coles, B.R. *et al.* (1993) *The Scientific, Technical and Medical Information System in the UK*, British Library R&D Report No.6123. p6 & p44.

Crawford, Hurd and Weller (1996) and Hurd (1996) explored variations of the Garvey-Griffith model relating to possible changes brought about by the emergence of electronic publishing, focusing primarily on the stages or steps in the research and communication/publishing process. The model highlights the range of scholarly communication activities falling outside publishing, and represents formal publishing as the culmination of a communication process that begins with research and preliminary reports, moving through conferences and pre-prints, and on to journal publication, abstracting and indexing, reviews and citations (Figure 1.3).

Figure 1.3: The Garvey-Griffith model outlined by Crawford *et al.*

Source: Hurd, J.M. (1996) 'Models of Scientific Communications Systems,' in Crawford, S.Y., Hurd, J.M. and Weller, A.C. Eds. (1996) *From Print to Electronic: The Transformation of Scientific Communication*, Information Today Inc. Medford NJ, p11. Copyright © 1996 by American Society for Information Science & Technology (ASIS&T). Used by permission. All rights reserved.

Following Lynch (1993), Hurd (1996, p14) distinguished between *modernisation* (i.e. the move online of traditional scholarly journal publishing processes, with attendant efficiency improvements), and *transformation* (i.e. the emergence of new forms of scholarly communications enabled by online technologies). Models suggested included:

- A modernised Garvey-Griffith model, with electronic submission, review and publication bringing increased speed and efficiency of processes and wider dissemination;
- A non-journal model, in which the article becomes the unit of distribution based on self-archiving;
- An unvetted model, in which peer review is dispensed with in favour of a less formal process of review and accountability based on OA archives/repositories keeping all versions of the article with its related commentaries; and
- A collaboratory model, in which online discussions lead to deposit of data and annotations in repositories, with reports made available after the data are annotated and vetted by peers.

An envisaged benefit of self-archiving in these various models is improved peer review, with review becoming more efficient and faster, more broadly-based and open, and more of a process (Hurd, *et al.* 1996, p102).

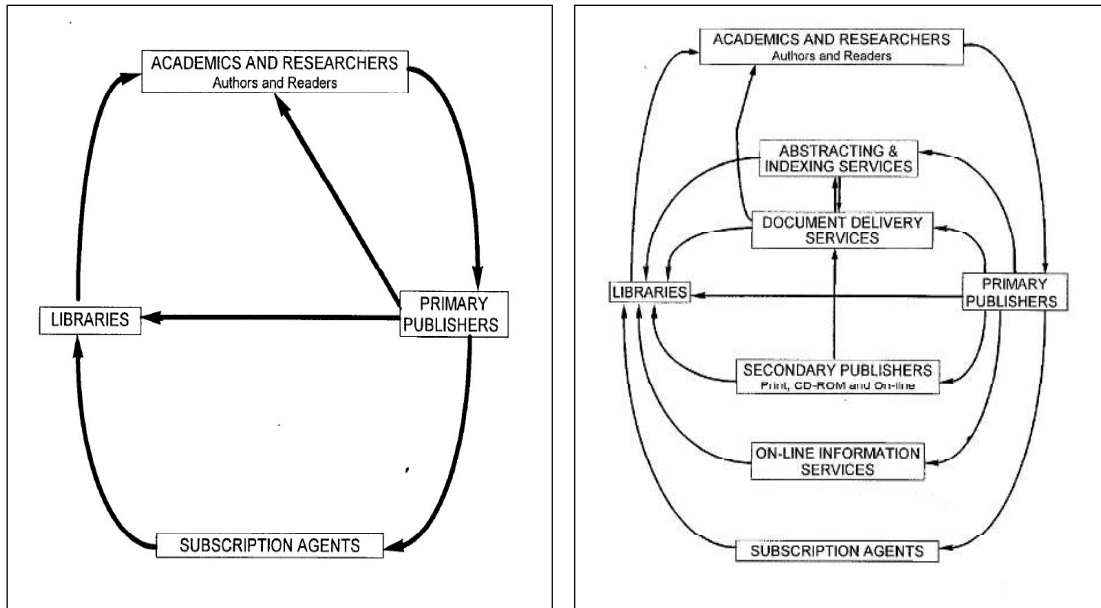
Cox (1998, p69) noted that scholarly publishing was undergoing a transformation that affected every participant in the information chain. He suggested that whereas journal publishing used to

be a relatively uncomplicated activity, driven by the need of scholars and researchers to publish (Figure 1.4a), things were becoming more complex and uncertain (Figure 1.4b), and the future looked even more so (Figure 1.5). The key feature of these models is the increase in the number of actors and in the complexity of their interactions and interdependencies.

Figure 1.4: The traditional and 1980s models of scholarly publishing

(Figure 1.4a) The traditional model

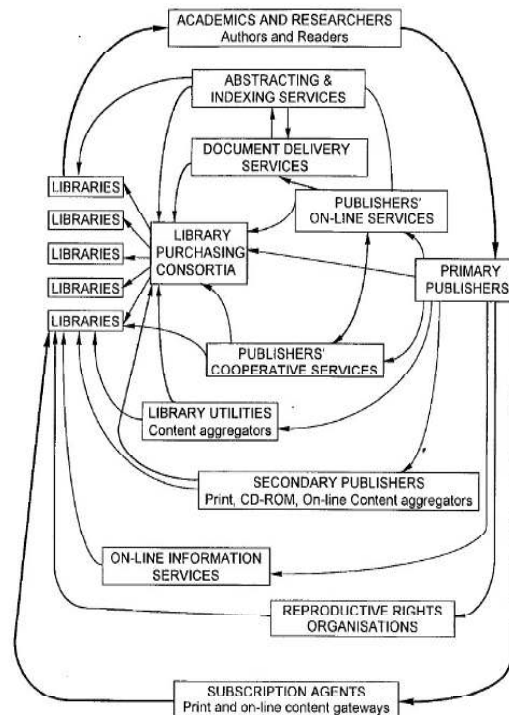
(Figure 1.4b) The 1980s model



Source: Cox, J. (1998) 'The changing economic model of scholarly publishing: uncertainty, complexity and multi-media serials,' *INSPEL* 32(2), pp69-78.



Figure 1.5: The new model of scholarly publishing, circa 1998



Source: Cox, J. (1998) 'The changing economic model of scholarly publishing: uncertainty, complexity and multi-media serials,' *INSPEL* 32(2), pp69-78.

Halliday and Oppenheim (1999) explored various economic models for electronic publishing, with an emphasis on publishing and library and other intermediary-related distribution activities. In so doing they identified a number of costs on the distribution and delivery side. Halliday and Oppenheim (1999, p4) noted that:

*As electronic alternatives to traditional library services are developed, shifts occur in the roles and activities undertaken by different stakeholders in the academic information delivery chain. Consequently, there have been sometimes unanticipated changes in the apportionment of costs and benefits to those stakeholders... A useful economic model of the digital library must accurately represent all stakeholders in the academic information delivery chain, their relationships to the supply and delivery of digital resources, and the associated costs and benefits.*

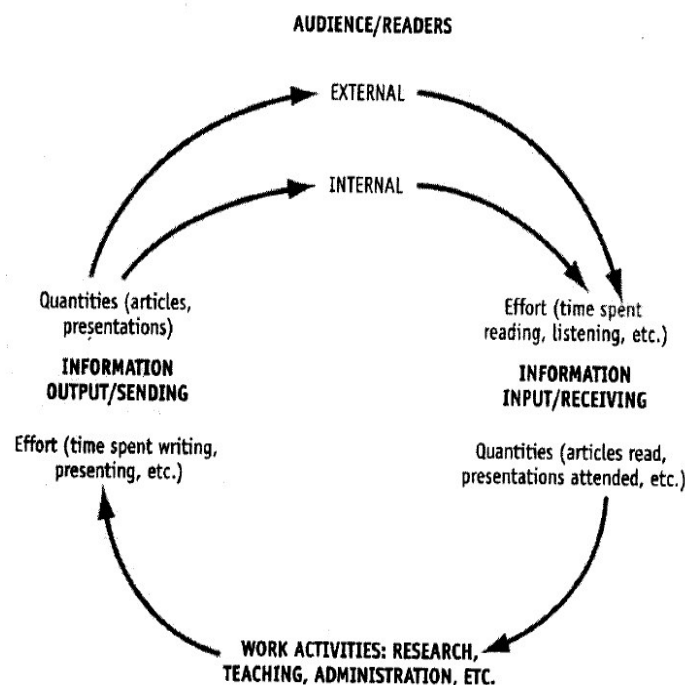
They suggested that the principal stakeholders (actors) involved in digital libraries at that time included: academics as authors and academics as editors and referees; end users (including academics as researchers, students, and clinical, professional and industrial users of electronic academic information); academics as teachers and recommenders of texts; higher education librarians; higher education computing support departments; publishers of both primary and secondary literature (commercial, not for profit, university presses, etc.) and other electronic content suppliers (such as museums); booksellers; funding bodies; subscription agents; national libraries; document suppliers, such as the British Library Document Supply Centre (BLDSC); reproduction rights organisations; intermediaries, such as the National Electronic Site Licence



Initiative (NESLI) and Higher Education Resources ONdemand (HERON); and Internet service providers and other aggregators and distributors. They suggested that these stakeholders were both individuals and organisations of both present and future generations, with some groups having a more direct stake than others. Arguably, the most important being: academics as authors, academics as users of scholarly information, academics as teachers, higher education libraries and librarians, publishers and information brokers (including subscription agents and document supply agencies) (Halliday and Oppenheim 1999, pp4-5).

Tenopir and King (2000) outlined a systems framework in which they explored a number of models of the scholarly publishing process. Putting publishing into its broader 'life-cycle' context, they adapted a model first put forward by Griffiths and King (1993) (Figure 1.6). At the heart of the model are the activities that scientists perform, such as research, teaching and management. The resources consumed in these activities include time spent writing and presenting, and outputs include quantities of articles and presentations. Authors are also readers, although the majority of readers are not authors. Hence, the reader audience is seen to be both internal and external, with the resources consumed including the time spent reading and listening. Nevertheless, the model depicted did not include the outputs/outcomes of the information received by external audiences, such as professionals in medicine, engineering, law, librarians and a range of professionals in such fields as management consulting, government and non-profit/non-government organisations.

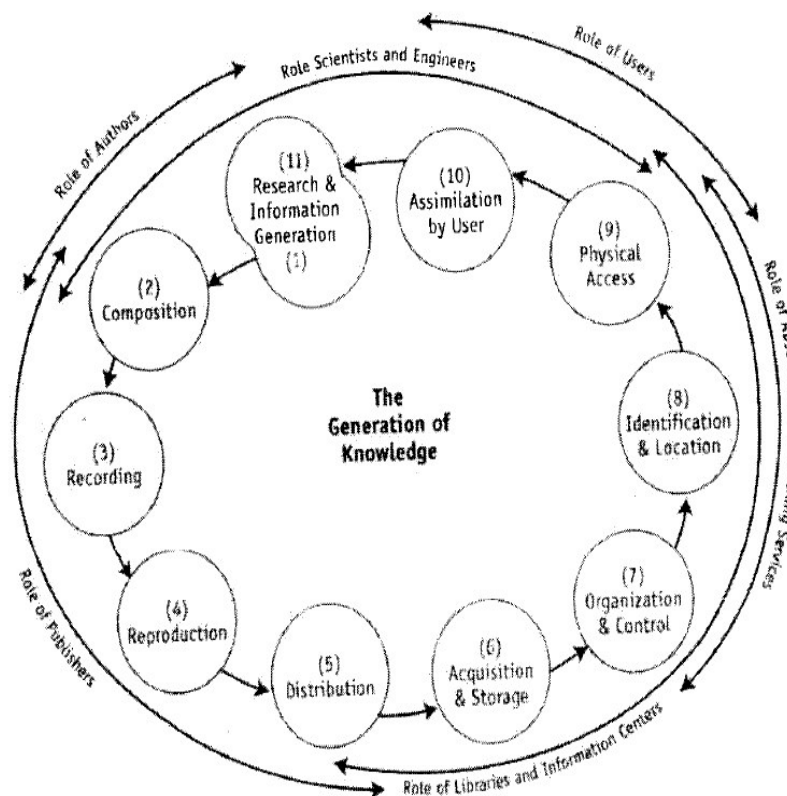
Figure 1.6: Scientists' communication cycle (Adapted from Griffith and King, 1993)



Source: Tenopir, C. and King, D.W. (2000) *Towards Electronic Journals: Realities for Scientists, Librarians and Publishers*, Special Libraries Association, Washington D.C., p87.

Tenopir and King (2000) adopted the model developed by Garvey and others to explore in greater detail the possible pathways of scientific communication.<sup>12</sup> They looked at the various channels by which scientific information is communicated, and at the timing of flows through these channels. Building on work from the mid-1970s they also presented a life-cycle model, noting that scientific information is one output from research, which after a myriad of services and processes is also one of several input resources used by scientists – with that communicated through journals characterised by a spiral of the traditional generic processing functions of generation, composition, reproduction and distribution (Figure 1.7).<sup>13</sup> This model matches the various activities with actors, and it includes all participants in the life-cycle from creators (*i.e.* researchers as authors) through intermediaries (*e.g.* publishers, libraries, etc.) to users (*i.e.* including both researchers and professionals).

Figure 1.7: Life-cycle of scientific information through the scholarly journal system functions



Source: Tenopir, C. and King, D.W. (2000) *Towards Electronic Journals: Realities for Scientists, Librarians and Publishers*, Special Libraries Association, Washington D.C., p89. Derived from King *et al.* 1976.

<sup>12</sup> This model was also picked up by Crawford, Hurd and Weller (1996), discussed above.

<sup>13</sup> King, D.W., Lancaster, F.W., McDonald, D.D., Roderer, N.K. and Wood, B.L. (1976) *Statistical Indicators of Scientific and Technical Information Communication (1960-1980)*, 3 Volumes, Report to the National Science Foundation C-878. King Research, Inc., Center for Quantitative Sciences (GPO 083-000-00295-3).

Tenopir and King (2000, pp96-98) listed the participants in the scholarly journal system as follows:

- *Creators* – the scientists, engineers and other professionals who perform the research and report results (motivated by the pursuit of knowledge, research funding and career advancement);
- *Reviewers and referees* – the fellow scientists, engineers and other professionals who provide authentication (usually unpaid, and motivated by the desire to contribute to their profession and reciprocity);
- *Primary publishers* – the publishing organisations who acquire manuscripts, edit, arrange peer review, produce and distribute publications, etc. (including commercial publishers motivated by profit and society and institutional publishers motivated by professional and institutional goals);
- *Secondary publishers* – those who provide abstracting and indexing services, etc. (typically for profit);
- *Second party distributors* – who package and distribute various collections assembled so as to appeal to particular customers, and provide document delivery services (typically for profit, although some libraries also undertake these roles);
- *Third party distributors* – who add packaging and distribution services (typically for profit);
- *Libraries* – who serve as intermediaries, acquiring content to be shared by users, and as an archive preserving content for future use (as institutional entities they are motivated by the goals of the institution);
- *Subscription agents* – who manage subscriptions on behalf of clients (typically for profit);
- *Information brokers* – who provide search and delivery services to clients such as libraries (typically for profit);
- *Computer and network facilities* – who provide the infrastructure for online access, storage and delivery; and
- *Readers* – who are the researchers and other users who make use of the content in their scientific and professional roles.

Tenopir and King (2000, p98) also noted a number of other participants that do not directly process the information, but who significantly affect the system, such as:

- *Government and other research funders* – who fund the research and seek to realise its value to themselves and/or to society at large;
- *Parent organisations* – who support the research and/or reading activities of their staff, and the activities of other participants (*e.g.* computer and network facilities, libraries, etc.) such as universities, government agencies, firms in various industries, non-government organisation, etc.;

- *Copyright granting and royalty collection agencies* – who provide economic protection to publishers; and
- *Professional societies* – who contribute to facilitating scholarly communication in a variety of ways.

It is notable that increasing online/electronic delivery has led to some ‘disintermediation’, with somewhat less use of second and third party aggregators and distributors, subscription agents and information brokers than was the case just eight years ago (for journals, at least). Nevertheless, this list of participants (actors) stands the test of time in providing one of the most complete views of the scholarly journals life cycle, and the take-off point for subsequent work in the area. Of crucial importance is the authors’ noting of systemic and economic interdependencies.

Taking a more economic approach, PIRA (2003) adopted a value networks / supply networks approach based on the work of Normann and Ramirez (1993), who suggested that: “the focus is not the company or even the industry but the value-creating system itself, within which different economic actors – suppliers, business partners, allies, customers – work together to co-produce value. Their key strategic task is the reconfiguration of roles and relationships among this constellation of actors in order to mobilize the creation of value in new forms and by new players.” Thus stressing the fluidity and complexity to a greater extent than does the notion of value chain.

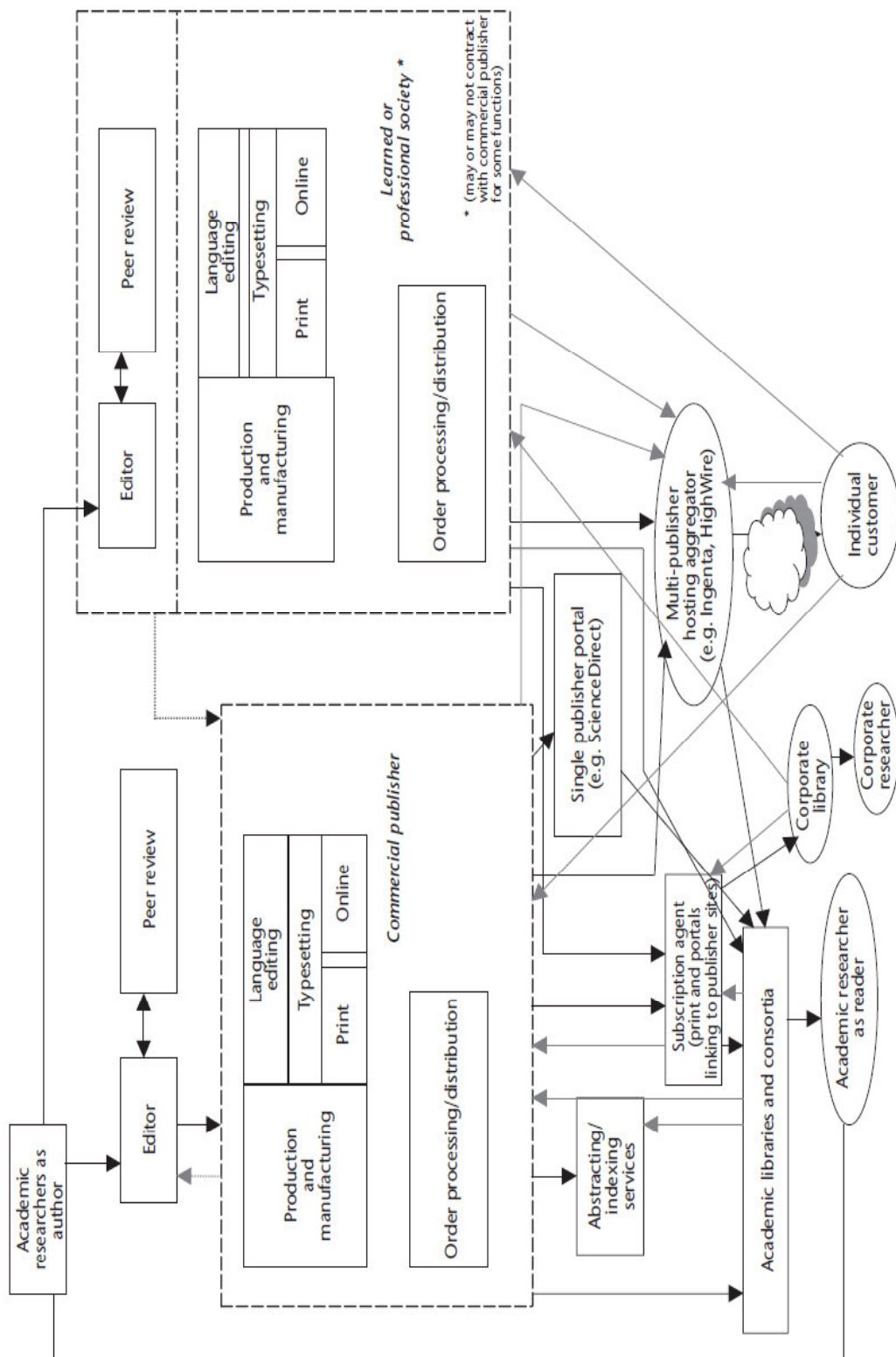
RIRA (2003, pp33-34) noted that the value networks of all content industries share some common characteristics, including: increasingly fluid and non-linear relationships between actors; a shift towards products being provided in the context of a service and other value added elements; that they are customer-centric and therefore dependent on exchanges of strategic information, planning knowledge, process knowledge and of collaborative practices in fields such as design and integration; and they rely in part on intangible as well as tangible measures, such as the exchange of value and similar benefits. These may include co-branding opportunities, brand extension and the creation of communities and customer loyalty. They suggested that operators of closed networks and providers of exclusive content may be challenged by disruptive technologies which may circumvent or challenge their position within the value network, shifting power to new forms of intermediary.

PIRA (2003, pp37-40) outlined schematic journal and book publishing value networks (Figures 1.8 and 1.9). While not specifically addressing scholarly publishing in the case of books, their model highlights the complexity of the book publishing process and the involvement of numerous actors.<sup>14</sup>

---

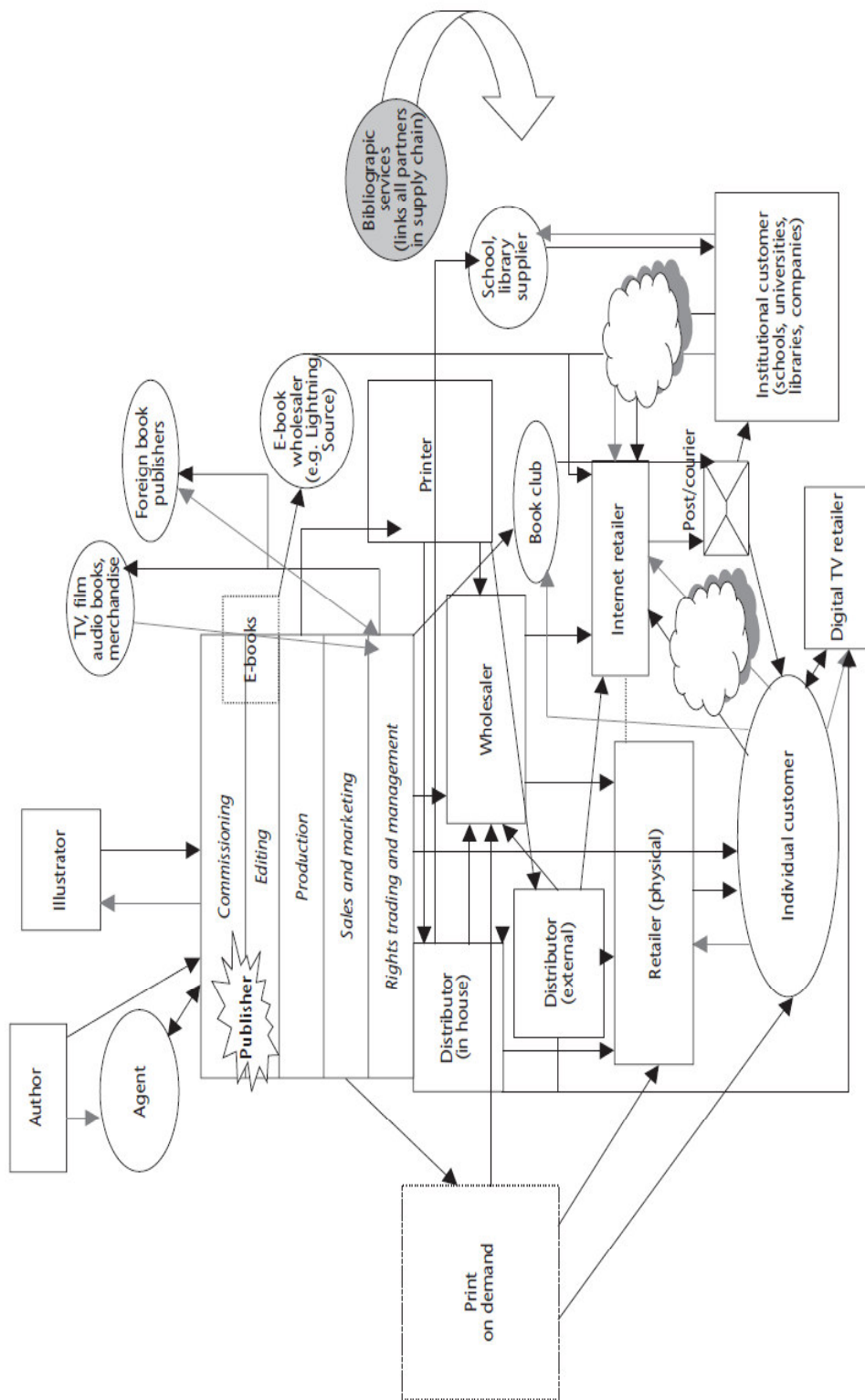
<sup>14</sup> PIRA distinguished between consumer and institutional book publishing according to final demand.

Figure 1.8: Journal publishing activities and flows



Source: PIRA International (2003) *The EU Publishing Industry: An assessment of competitiveness*, European Commission, Brussels, p40.

Figure 1.9: Book publishing activities and flows



Source: PIRA International (2003) *The EU Publishing Industry: An assessment of competitiveness*, European Commission, Brussels, p37.



Björk (2007) developed a formal model of the scholarly communication life-cycle to act as a roadmap for policy discussion and research concerning the process. Based on the IDEF0 process modelling method often used in business process re-engineering, it provided the first detailed ‘map’ of the scholarly publishing process. Björk’s model included the activities of the:

- Researchers who perform the research and write the publications;
- Publishers who manage and carry out the actual publication process;
- Academics who participate in the process as editors and reviewers;
- Libraries who help in archiving and providing access to the publications;
- Bibliographic services who facilitate the identification and retrieval of publications;
- Readers who search for, retrieve and read publications; and
- Practitioners who implement the research results directly or indirectly.

Björk’s central focus was the single publication (primarily the journal article), how it is written, edited, printed, distributed, archived, retrieved and read, and how eventually it may affect practice. The scope is thus the full life-cycle of the publication. Björk (2007, p7) suggested that analysing the whole process in this way should help in highlighting how different actors provide added value to the end customers at each stage. It is, therefore, close in spirit to the concept of value chain or value system analysis.

In various guises, Björk’s model consisted of 33 to 35 diagrams (each relating to particular functions) and identified 103 to 113 activities organised under the principal activities identified at the top of the hierarchy, namely: fund R&D, perform the research, communicate the results, and apply the knowledge.<sup>15</sup>

### *1.3.2 The scholarly communication process model*

In order to provide a solid foundation for a detailed analysis of the implications of alternative scholarly publishing models for various actors within the scholarly communication system, we have developed and extended Bo-Christer Björk’s model using the same IDEF0 process modelling method as it provides the best platform for analysis – being capable of development to the required level of detail and providing an hierarchical structure permitting detailed views of activities in some parts of the scholarly communication value chain and more aggregated views in others. The work is based on and draws heavily on that of Bo-Christer Björk and has benefited from his very generous assistance in its development.

### **A brief introduction of IDEF0 process modelling**

An activity model is a structured representation of the activities that occur in a production system and the information and objects that link those activities (KBSI 2005).

---

<sup>15</sup> A version of Björk’s model can be seen at: <http://informationr.net/ir/12-2/paper307.html>

Model diagrams consist of:

- **Activities** – which define a unique activity within the process and are represented as boxes. These can be broken down (decomposed) into sub-activities at lower levels of the model hierarchy.
- **Controls** – which frame, control or constrain the activity and enter the diagram from the top. These can be things like rules, regulations, norms, budgets, etc.
- **Mechanisms** – which define the actors or participants and infrastructures on which the activity depends and enter the diagram from the bottom. These can be actors, such as researchers, publishers and infomediaries, or things like IT systems, libraries, archives and repositories.<sup>16</sup>
- **Inputs** – which define the inputs to the activity, and often trigger an occurrence of the activity or process. They enter the diagram from the left.
- **Outputs** – which are produced by the activity. Outputs from one activity are often inputs to another. They exit the diagram from the right.

The overall process being modelled is defined at the highest level, and the activities and sub-activities that contribute to the process are presented in an hierarchical structure. The level of decomposition of activities can be as great or limited as the application requires, allowing one to identify major elements at an aggregate level in some areas of the system while drilling down to a greater level of detail in others.<sup>17</sup>

### Scholarly communication and the structure of the process model

The scholarly communication process involves conducting research, communicating and applying results. Scientific/scholarly curiosity, economic and career incentives guide activities; work addresses scientific/scholarly problems and builds on existing knowledge. It involves a wide range of stakeholders in the research and communication process, and results in the generation of new knowledge, the study and application of which spreads the knowledge and seeks to contribute in some way towards an improved quality of life (Figure A).<sup>18</sup>

---

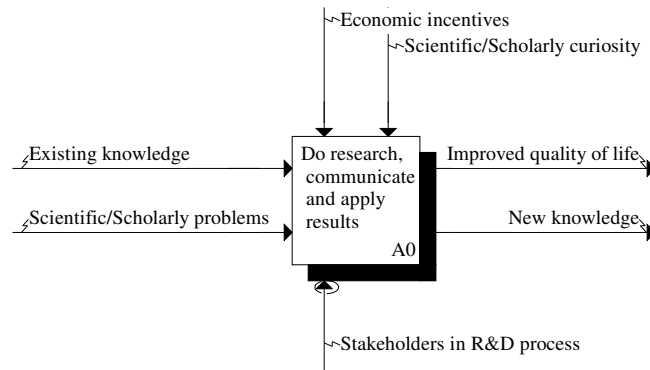
<sup>16</sup> The term actor is preferred as the model focuses on activities, with actors being participants in those activities.

<sup>17</sup> The AIOWin modelling software used for this study supports both detailed description and analysis of processes *and* integrated activity costing (Erraguntla and Benjamin 2007).

<sup>18</sup> Figures are numbered according to the hierarchical modelling structure (*e.g.* Figure A11 is the first decomposition of Figure A1, Figure A12 the second decomposition, and so on).



Figure A: The scholarly communication process

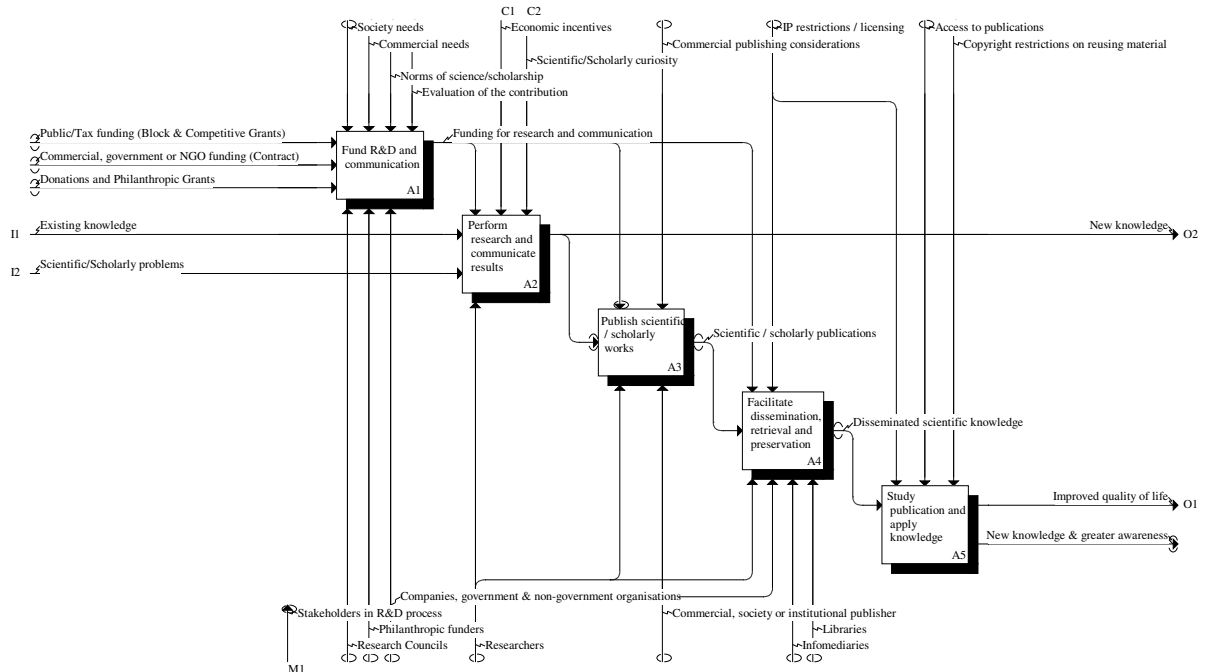


Link: <http://www.cfses.com/EI-ASPM/SCLCM-V7/>

Source: Scholarly Communication Process Model: Authors' analysis.

Extending the model outlined by Björk (2007), the scholarly communication process model developed for this study includes five core scholarly communication process activities, namely: (i) fund research and research communication; (ii) perform research and communicate the results; (iii) publish scientific and scholarly works; (iv) facilitate dissemination, retrieval and preservation; and (v) study publications and apply the knowledge (Figure A0).

Figure A0: Do research, communicate and apply results



Link: <http://www.cfses.com/EI-ASPM/SCLCM-V7/>

Source: Scholarly Communication Process Model: Authors' analysis.

This diagram (Figure A0) defines the model's structure and outlines the key top level activities, inputs, mechanism, controls and outputs. The overall hierarchical structure of the model is as follows.

## **A0: Do research, communicate and apply results**

### ***A1: Fund R&D and communication***

- A11: Set policy and direction
  - A111: Lobby for and obtain funds
  - A112: Set priorities and design funding programs
  - A113: Set criteria for evaluation
  - A114: Advertise and promote availability of funds
- A12: Evaluate research proposal
  - A121: Manage proposal evaluation
  - A122: Review proposals
  - A123: Obtain clarification / development
- A13: Make funding decisions
- A14: Evaluate impacts/outcomes
  - A141: Evaluate research quality
  - A142: Evaluate research impacts
  - A143: Evaluate efficiency and effectiveness
  - A144: Synthesise and evaluate research

### ***A2: Perform research and communicate results***

- A21: Perform research
  - A211: Study existing scientific knowledge
  - A212: Collect data from existing databases/repositories
  - A213: Do experiments, make observations and collect data
  - A214: Analyse & draw conclusions
  - A215: Develop new research proposals
- A22: Communicate the knowledge
  - A221: Communicate results informally
    - A2211: Prepare research reports
    - A2212: Prepare conference papers
    - A2213: Attend / Present at conferences
    - A2214: Inform and discuss
  - A222: Communicate results formally (prepare for publication)
    - A2221: Write manuscript
    - A2222: Seek & obtain permissions
    - A2223: Choose how & where to publish
    - A2224: Tailor manuscript to outlet
    - A2225: Self-archive
  - A223: Share data / models
    - A2231: Share/publish data
    - A2232: Share/publish models
    - A2233: Share/publish algorithms & sequences
    - A2234: Share/publish audio & video

### ***A3: Publish scientific / scholarly works***

- A31: Publish as Journal Article
  - A311: Publishers' general activities (Journal)
    - A3111: Develop IT platform for handling manuscripts & publication (Journal)
    - A3112: Identify, finance and establish new titles
    - A3113: Recruit and manage editor & editorial board
    - A3114: Operate & manage editorial board meetings

## Economic implications of alternative scholarly publishing models

- A312: Journal specific activities
  - A3121: Market journal
  - A3122: Negotiate & manage subscriptions and other funds
  - A3123: Plan and manage issues
- A313: Process article
  - A3131: Select manuscript for review
  - A3132: Peer review (Article)
    - A31321: Manage review process
    - A31322: Review manuscript
    - A31323: Revise manuscript
  - A3133: Negotiate copyright or license (Article)
  - A3134: Collect article charges (author-pays)
- A314: Produce and process non-article content
  - A3141: Produce editorial and letters
  - A3142: Produce review articles
  - A3143: Generate advertising and sponsor content
  - A3144: Produce covers and index
  - A3145: Collect and collate non-article content
- A315: Technical phases of publishing (Journal)
  - A3151: Copyedit article and non-article content
  - A3152: Queue for publishing
  - A3153: Embed in issue
  - A3154: Distribute issue / article (Open Access)
    - A31541: Publish electronic version (Open Access)
  - A3155: Duplicate and distribute issue / article (Toll Access)
    - A31551: Print paper issue
    - A31552: Distribute paper issue to subscribers
    - A31553: Control access to electronic version
    - A31554: Publish electronic version (Toll Access)
- A32: Publish as a Conference Paper
- A33: Publish as a Monograph
  - A331: Publish as a report
  - A332: Publish as a thesis/dissertation
  - A333: Publish as a book
    - A3331: Publishers' general activities (Book)
      - A33311: Develop IT platform for handling manuscripts & publication (book)
      - A33312: Operate editorial activities
      - A33313: Recruit authors & content
    - A3332: Editorial / peer review
      - A33321: Manage peer review process (Book)
      - A33322: Review manuscript (Book)
      - A33323: Revise manuscript (Book)
    - A3333: Negotiate copyright or license (Book)
    - A3334: Negotiate & process royalties or payments
    - A3335: Technical phases of publishing (Book)
      - A33351: Copyedit manuscript (Book)
      - A33352: Queue for publishing (Book)
      - A33353: Embed in series or list (Book)
      - A33354: Market and sell books/series
      - A33355: Duplicate and distribute (Book)
        - A333551: Print paper book and bind
        - A333552: Distribute paper book
        - A333553: Handle sales data and returns
        - A333554: Control access to electronic version (Book)
        - A333555: Publish electronic version (Book)

**A4: Facilitate dissemination, retrieval and preservation**

- A41: Facilitate dissemination
  - A411: Develop IT platform for dissemination
  - A412: Manage and operate dissemination platform (Archives, Repositories, Websites, etc.)
- A42: Facilitate retrieval
  - A421: Facilitate retrieval globally
    - A4211: TOLL ACCESS: Make publications/data available to subscribers/buyers
      - A42111: Post on publisher website
      - A42112: Post in proprietary access system
      - A42113: Control access
    - A4212: OPEN ACCESS: Make publications/data openly available
      - A42121: Post on personal, publisher or institutional website
      - A42122: Post in institutional repository
      - A42123: Post in subject archive
    - A4213: Integrate metadata into search services
      - A42131: Index in edited bibliographic index
      - A42132: Index in web harvester for scientific content
      - A42133: Index in general web search engine
  - A422: Facilitate retrieval locally
    - A4221: Negotiate accessions, subscriptions and licenses
    - A4222: Make toll access publication available inside organisation
      - A42221: Subscription processing
      - A42222: Catalogue items obtained
      - A42223: Physical processing and handling
      - A42224: Establish and operate authentication system
      - A42225: Physical checkout and handling
      - A42226: Reader/user support
    - A4223: Make OA publications available inside organisation
      - A42231: Catalogue and/or provide links
      - A42232: Reader / user support
    - A4224: Obtain individually requested item
- A43: Facilitate preservation
  - A431: Facilitate preservation (print)
  - A432: Facilitate preservation (electronic toll access)
  - A433: Facilitate preservation electronic (open access)

**A5: Study publication and apply knowledge**

- A51: Study publication
  - A511: Find out about the publication
    - A5111: Search for interesting publications
      - A51111: Use dedicated search service for scientific publications
      - A51112: Use general web search engines
      - A51113: Search library catalogue / browse shelves
    - A5112: Be alerted to publications
      - A51121: Receive recommendation from colleague
      - A51122: Receive an electronic alert
      - A51123: Notice reference in other publication
  - A512: Consider buying access to publication
  - A513: Retrieve publication
    - A5131: Retrieve paper publication
    - A5132: Retrieve electronic publication
  - A514: Read & process publication
    - A5141: View, print or copy publication
    - A5142: Read publication
      - A51421: Read for research purposes
      - A514211: University research

## Economic implications of alternative scholarly publishing models

- A514212: Industry research
- A514213: Government research
- A514214: NGOs (industry bodies, lobby groups, etc.)
- A514215: Publish secondary accounts
  - A5142151: Report on lists & blogs
  - A5142152: Report in review articles
  - A5142153: Incorporate into textbooks & teaching materials
  - A5142154: Report in the popular media
- A51422: Read as part of education
- A51423: Read for professional information & development
- A51424: Read to increase knowledge
- A5143: File (self-archive) for future reference
- A52: Apply the knowledge
  - A521: Educate professionals
    - A5211: Produce teaching material & reading lists
    - A5212: Teach students
    - A5213: Teach practitioners
  - A522: Make policy and regulate
    - A5221: Define public policy and legislate
    - A5222: Define standards
    - A5223: Grant patents
  - A523: Do industrial development
  - A524: Apply in practice
    - A5241: Apply new knowledge in treatment of patients
    - A5242: Apply new knowledge in professional practice (law, engineering, etc.)
    - A5243: Apply new knowledge in industrial R&D
    - A5244: Apply new knowledge in life-style and consumption choices
    - A5245: Apply new knowledge in public debate

In its current form the model includes 53 diagrams and 190 activities (Version 7.0). Its development is on-going.<sup>19</sup>

---

<sup>19</sup> Details of the entire model in 'browseable' form can be found on the Web at: <http://www.cfses.com/EI-ASPM/SCLCM-V7/>

## Part I: Identification of costs and benefits

Part I seeks to identify all the dimensions of cost and benefit for each of the three models for scholarly publishing, and examine which of the main players in the scholarly communication system would be affected, and how they might be affected, by each of the costs and benefits identified.

## 2 Identifying costs

The extended scholarly communication process model provides a foundation for a detailed identification of the actors, activities, objects and functions involved in the entire scholarly communication process, and of the costs and funding flows involved. In the following sections, we use it, together with a brief review of the literature, to identify costs and explore the implications of alternative scholarly publishing models.

As noted above, the extended process model includes five core scholarly communication life-cycle activities: (i) fund research and research communication; (ii) perform research and communicate the results; (iii) publish scientific and scholarly works; (iv) facilitate dissemination, retrieval and preservation; and (v) study publications and apply the knowledge. We deal with each of these in turn.<sup>20</sup>

Inevitably, a brief description of the scholarly communication process or life-cycle simplifies the process and makes it appear linear, with objects processed step-by-step from creation through consumption. In reality, of course, there are many complex interactions and feedbacks, with the major participants active throughout.

### 2.1 Fund research and research communication

Research funding and the activities of funding and grant agencies underpin and set the boundaries to research activities. Key activities are well known and largely generic, but there are important differences in the organisation and structure of different national funding systems.

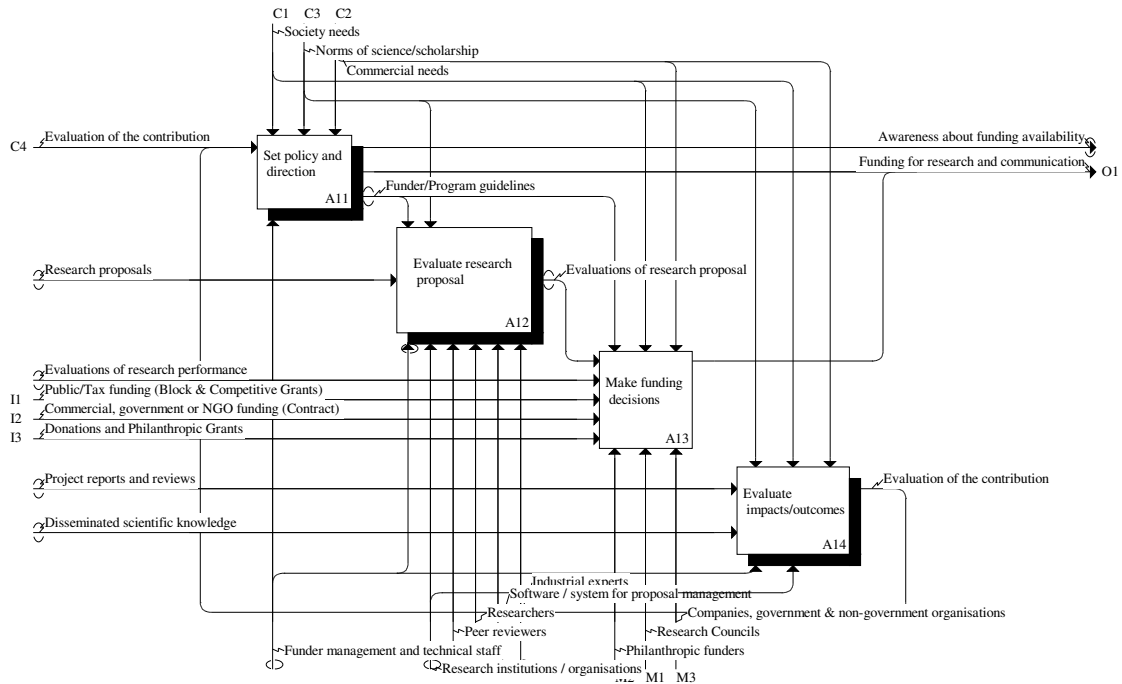
Extending the model outlined by Björk (2007), we suggest that the core activities involved in funding research include: setting policy and direction; evaluating research proposals and grant applications; making funding decisions; and evaluating the overall impacts and outcomes of the funding programme(s) and agency (Figure A1). Each of these activities is outlined in the following process model diagrams, with sub-activities identified along with the controls, mechanisms, inputs and outputs involved in the process. A distinction is made between the major sources of funds and types of funding (*i.e.* competitive grants, contract, block grant and philanthropic funding) as each is characterised by slightly different processes. This provides a

---

<sup>20</sup> Because of the global nature of research the scholarly communication process is largely generic, but where there are differences at a detailed level it is intended that the following descriptions represent the UK situation.

foundation for the identification of costs and impacts. As noted, the process is not as linear as the description suggests. Indeed, as accountability increases there is increasing funder participation throughout the process.

Figure A1: Fund research and communication



Link: <http://www.cfses.com/EI-ASPM/SCLCM-V7/>

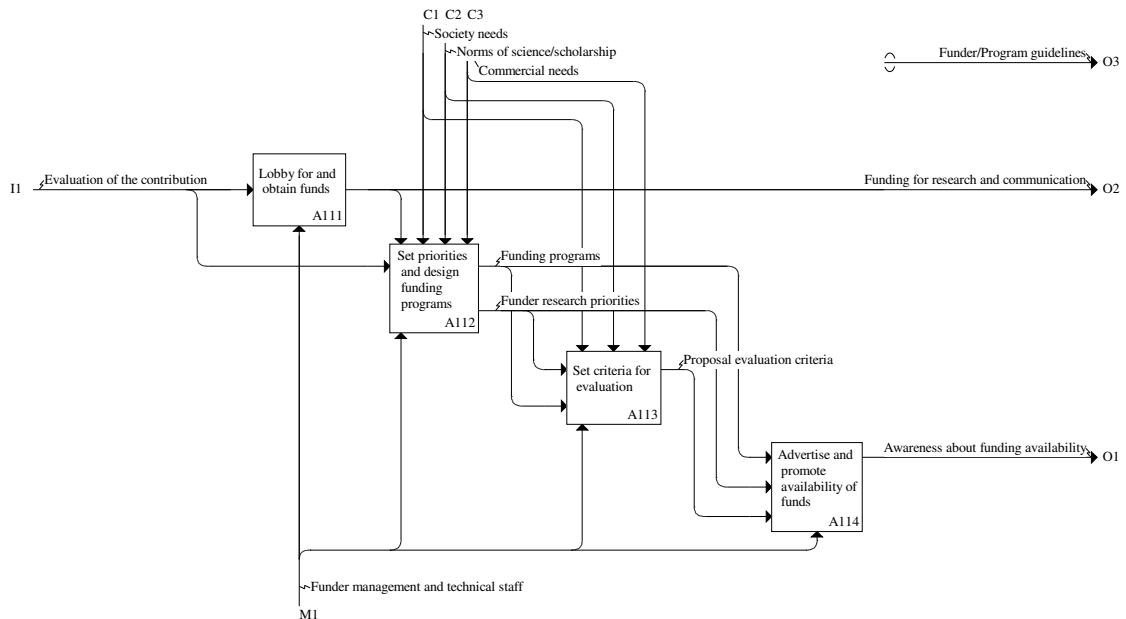
Source: Scholarly Communication Process Model: Authors' analysis.

### 2.1.1 Processes involved in funding research

**A11: Setting policy and direction** involves funding agencies lobbying for and obtaining funds, setting priorities and defining funding programs, setting the criteria for evaluating funding proposals, and advertising and promoting the availability of funds (Figure A11).

Funding agency or organisation staff undertake much of this activity with consultation and the support of outside experts. Setting priorities and designing funding programs will involve government and policy officials and ministers in the case of publicly funded programs and will reflect their needs and priorities, along with those of core funders in many of the private foundations and funding agencies. Criteria for evaluation are likely to be developed in consultation with the academies, learned societies and disciplinary experts, and to take account of the norms of science/scholarship (relating to The Arts, Humanities and Social Sciences as well as The Natural Sciences), as well as economic and social needs and funder priorities. Evaluation increasingly includes these broader industrial and social impacts.

Figure A11: Set policy and direction



Link: <http://www.cfses.com/EI-ASPM/SCLCM-V7/>

Source: Scholarly Communication Process Model: Authors' analysis.

**A12: Evaluating research proposals / grant applications** is a major task for most funding agencies. It involves managing the proposal evaluation process, reviewing proposals internally and/or externally, where necessary obtaining clarification and development from the applicant, and accepting or rejecting applications (Figure A12). Slight variations on this process will be used in the cases of unsolicited proposals and for stepped approaches in which, for example, there may be preliminary calls for outline proposals.

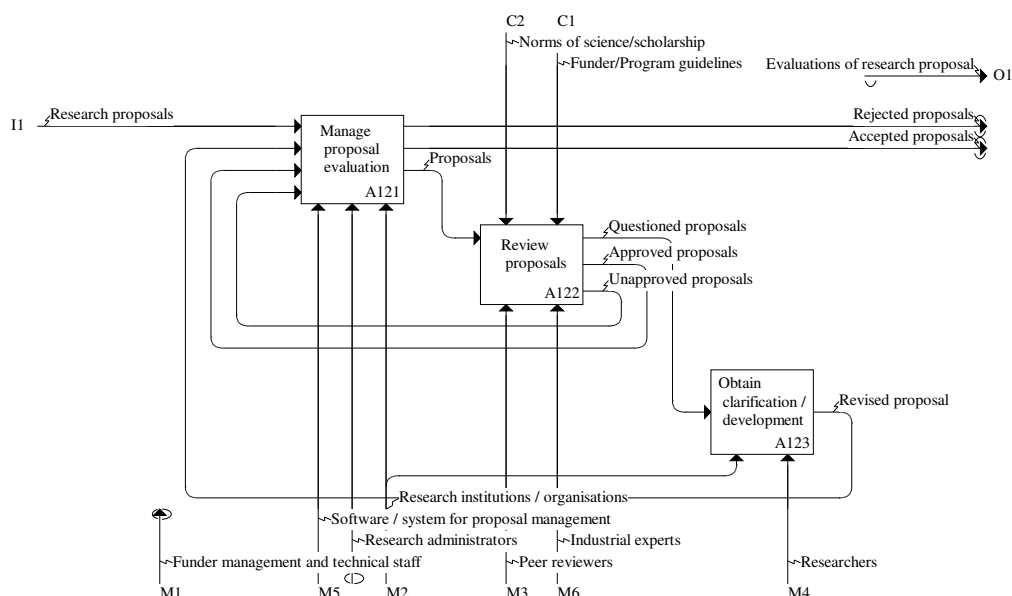
Not only will these activities consume a good deal of the time and attention of agency staff, they will also involve a range of external actors – including university and research centre research management and administration, external peer reviewers and industry experts, and the researchers/applicants themselves.

Tracking and reporting on evaluation and grants is a central function of most funding agencies and will involve the development and operation of supporting information systems and a number of technical and administrative staff.

The preparation and submission of research proposals from the researchers' perspective is discussed under '*perform research*' (Figure A21 below).



Figure A12: Evaluate research proposals/grant applications



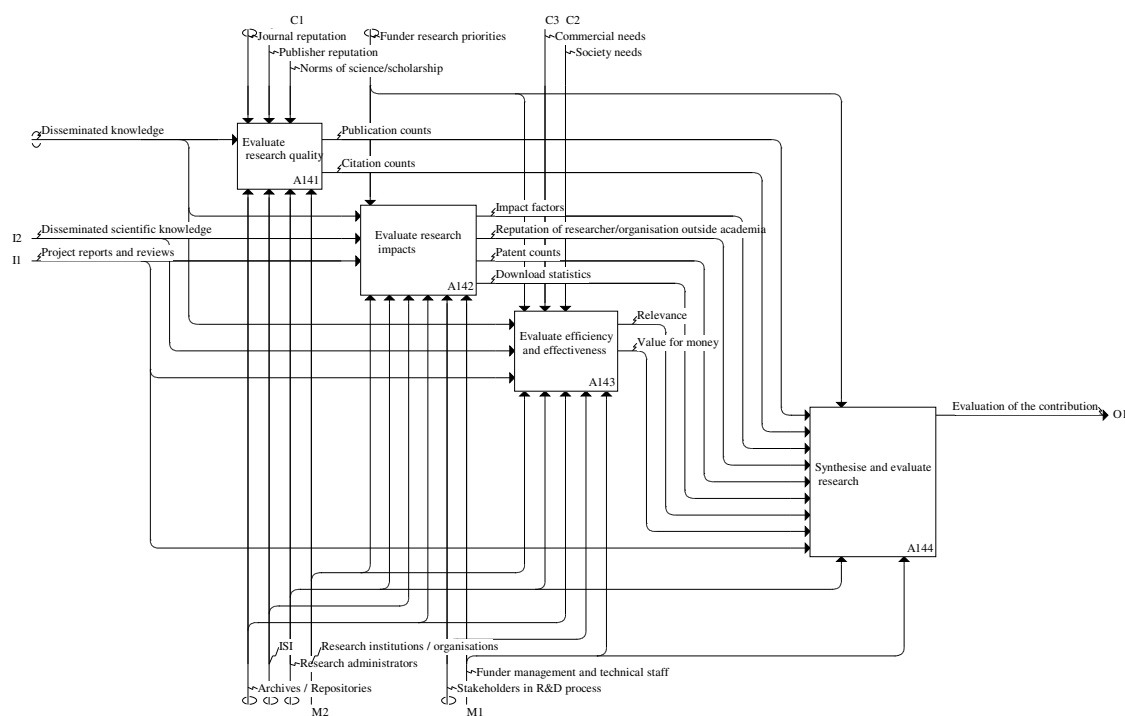
Link: <http://www.cfses.com/EI-ASPM/SCLCM-V7/>

Source: Scholarly Communication Process Model: Authors' analysis.

**A14: Evaluating impacts and outcomes** of funded research provides necessary feedback to funders and supports funding agencies' efforts in lobbying for and obtaining funds. It involves tracking and recording outputs and outcomes, evaluating the quality of the research undertaken as a result of funding grants, evaluating the impacts of the research, evaluating the efficiency and effectiveness of the research in achieving its and the agencies goals as well as contributing to the development of knowledge, economic and social needs, and synthesising all of the above into an overall evaluation of the contribution of the research funded (Figure A14). This forms a key element of the agencies' reporting and/or overall evaluation (*e.g.* the former RAE and forthcoming REF).

Again, both internal administrative and technical staff will be involved, supporting information systems necessary, and a range of external resources and sources will be drawn on to provide information – including university and research centre research management and administration, external peer reviewers and industry experts, and the researchers/applicants themselves, as well as such sources as publisher and repository metrics, and generalist and specialist suppliers of such metrics. These inputs may involve substantial costs.

Figure A14: Evaluate impacts and outcomes



Link: <http://www.cfses.com/EI-ASPM/SCLCM-V7/>

Source: Scholarly Communication Process Model: Authors' analysis.

### 2.1.2 Identification of the costs involved in funding research

Few analysts have examined research funder and funding costs systematically, although there are many possible sources ranging from government, funder and agency reporting (e.g. research council annual reports), occasional reviews of activities, and business and media reporting (e.g. that relating to the costs of operating the former RAE).

Very brief reviews of the literature on the costs involved in funding, reporting and evaluating research, and an identification of those costs, can be found in:

- Houghton, J.W. Steele, C. and Sheehan, P.J. (2006) *Research Communication Costs in Australia, Emerging Opportunities and Benefits*, Department of Education, Science and Training, Canberra.
- Björk, B-C. (2007) 'A model of scientific communication as a global distributed information system,' *Information Research* 12(2) paper 307.

Focusing on higher education in Australia, Houghton *et al.* (2006, p84) noted that: "Costs relating to research funding and management are substantial... Major costs relate to the review and management of competitive grants through research councils and other funding bodies, and the reporting activities required for research management and evaluation." They also explored

the operational costs of funding agencies, and the oversight and coordination costs of their funders (*e.g.* government) drawing on annual reports, reviews and media reporting. Because of the higher education focus of their study, however, attention was focused on calculating the costs of preparing grant applications by researchers and their supporting institutions, and of peer reviewing those applications on-behalf of the research councils. The costs associated with the operation of the major research councils and university research offices was also explored, but only in rather general terms.

Björk (2007) included *Fund R&D* as a separate activity in the overall scholarly communication life-cycle, noting that: “One reason for this is the importance research funders (understood in the widest sense including basic university funding) have in the shaping of the scientific communication chain, since they, through research contracts and university guidelines, have a strong indirect influence on where researchers choose to publish their work. Funding decisions are here understood to include both decisions about basic university funding (*e.g.* the UK RAE and REF), decisions about individual research grants and academic appointments.”

Table 2.1 presents a summary of the major cost items identified, based on the process model outlined above. The quantification of these costs is the topic of Part II of this report.

Table 2.1: Funding research and communication: major costs items

| <i>Activity/Item</i>                 | <i>Description</i>   |
|--------------------------------------|--|
| <b>Funding and agencies:</b>         |  |
| Operation of funding agencies        | Organisational strategy, priorities and directions; general overhead and operational costs.  |
| Grant funds and programs             | Operation of funds and programs, establishing and publishing criteria, etc.  |
| Grant application handling           | Handling of applications by program and by applicants (individual and institutional).  |
| Grant application reviews            | Handling the application review process (operation of review activities, information and guidelines, etc.) and reporting.  |
| Making funding decisions             | Assessing the reviews and making the funding decisions.  |
| Project & fund report handling       | Handling the submitted reports against funding, synthesising and consolidating into program and agency reporting.  |
| Overall evaluation & PR              | Managing overall evaluations of outcomes and impacts, reporting back to government and other funders, and communicating more broadly.  |
| <b>Evaluation:</b>                   |  |
| Research evaluation (Institutional)  | Collecting, collating and managing the necessary reporting, incl. costs of tracking and recording systems, staff involved in its management and time of research staff and departments spent generating the reports, as well as developing and managing institutional and departmental strategies and responses. |
| Research evaluation (Funding Agency) | Collecting, collating and managing necessary reporting to government, development and operation of supporting systems and processes.   |
| Research evaluation (Government)     | Development of policy for evaluation, consultation and development of indicators/metrics, collection and collation of reporting, preparation and "publication" of results of evaluations, ratings and rankings, etc.   |
| <b>Institutional (e.g. HEIs):</b>    |  |
| Research management                  | Operation of research offices at the institutional level, identification of funding opportunities, communications to internal stakeholders, management and operation of research evaluation related information management systems, etc.   |
| Funding program design               | Time of researchers and/or research managers who participate as experts in the design of funding programs and setting evaluation criteria.   |
| Grant application preparation        | Researcher time in preparing grant applications, formatting as required and revisions.   |
| Grant application handling           | Handling, recording and vetting the institutions grant applications; supporting and tracking individual applications across the range of funding agencies.   |
| Grant application reviews            | Time of researchers who act as peer reviewers for the funding organisations, and on expert committees making funding recommendations.  |
| Project reporting                    | Reporting on progress and outcomes relating to grants won ( <i>i.e.</i> involving researchers, departments and institutions).  |
| <b>Resources:</b>                    |  |
| Manual and IT systems                | Generic and specialist information systems to support the activities   |
| IT and supporting infrastructure     | Generic IT and supporting infrastructure.  |
| Specialist skills and services       | Specialist services and skills ( <i>e.g.</i> IT systems, publication metrics, etc.).   |
| Research evaluation metrics          | Development, provision and analysis of metrics ( <i>e.g.</i> download and citation counts, impact factors, etc.).  |

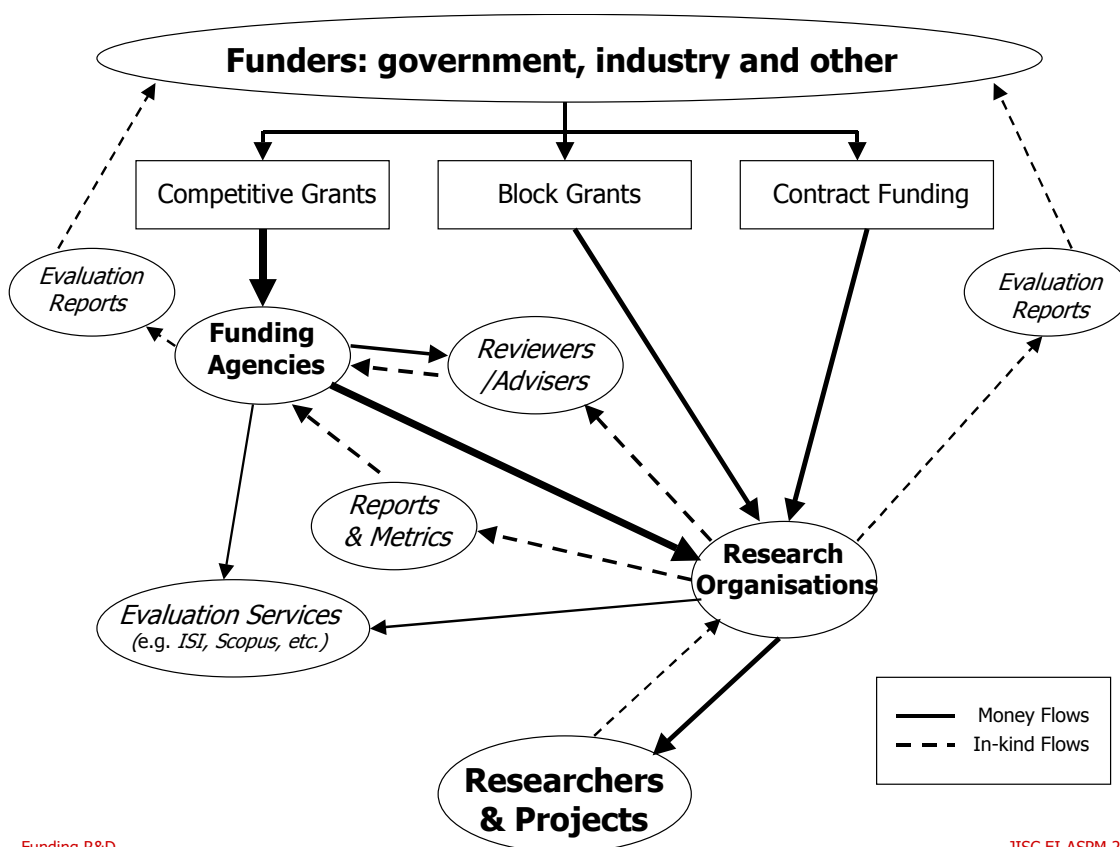
Source: Authors' analysis.

### 2.1.3 Funding flows relating to funding research

Funding flows relating to these research funding activities are relatively straightforward, with funding coming from government, industry and other private sources either for the support of the funding agencies' operations and the funded research itself (for competitive grants funding), or directly to the researchers or research institutions (for block grants and contract funding). Account must also be taken of the funders own related expenses (*e.g.* the government's internal allocation for the operation of the former RAE and future REF).

When funding is channelled through funding agencies (*e.g.* a research council) the agencies operational funding supports both internal and external actors and activities, with the latter including such things as payments to external experts to review proposals and for various systems and data required for evaluation (*e.g.* citation metrics, etc.). When the funding flows directly to the research organisation (*e.g.* contract research funding) costs of evaluation are typically moved up to the funder and reporting costs down to the research organisation.

Figure 2.1: Simplified funding flows relating to research funding



Funding R&D

JISC EI-ASPM 2008

Source: Authors' analysis.

The researchers and research organisations funded (*e.g.* universities and research centres) will typically allocate a fraction of the research funding to management and reporting activities or support those activities from other 'block' funding allocations. The research organisations'

supporting infrastructure may be funded as an element of project funding, but is more commonly dealt with through ‘block’ funding allocations for the more generic infrastructure (*e.g.* ICT equipment, intranets, buildings and facilities) and/or specific infrastructure grants for more specialised research infrastructure (*e.g.* specialist large-scale and laboratory equipment). Related consumables are typically funded through the research grant.

Increasingly, government, research councils and other funding agencies are allowing researchers and research institutions to pay publishing costs from their research grants and/or supporting OA publishing and/or OA self-archiving more directly. As a result, there is now emerging a more direct flow of funds between funders and publishers (not shown in the simplified diagram, above).

#### *2.1.4 The impacts of alternative publishing models on research funding activities*

There are a number of points at which differences in the operation of alternative scholarly publishing models may affect the activities and, thereby, the costs, benefits and funding flows involved in funding research and communication.

#### Costs and impacts

The main areas of cost impact are likely to be found:

- In the provision of funds to meet author publishing fees (*e.g.* for author-pays OA publishing), possibly subtracting marginally from the total funding available for other research activities;
- In external peer review activities, where greater ease of access to publications and related material may increase the efficiency and/or quality of peer review through, for example:
  - The ability of reviewers to access OA materials cited in the applications and check them for interpretation, etc. more quickly, easily and thoroughly;
  - The timeliness of ‘publication’ contributing to reviewers’ awareness and, thereby, increasing the chances of avoiding duplicative research, the pursuit of blind alleys, or missing the latest techniques and opportunities; and
  - The possibility of a more complete record of science emerging through more open access also contributing to reviewers’ awareness of possible blind alleys (*e.g.* greater reporting of negative findings);
- In the preparation of funding applications by applicants, where greater ease of access to publications and related material may increase the efficiency and/or quality of applications (for all the reasons noted in the previous point);
- In evaluation activities at the funder and funding agency levels, where those activities involve publication metrics, reporting or review, and where enhanced access might contribute to fuller reporting of outcomes by research centre and university research

management (*e.g.* through repository-based metrics enhancing available evaluation measures), or make such evaluation more difficult and costly (*e.g.* by fragmenting the literature into proprietary silos and making metrics more difficult to obtain);

- In reduced cost of externally sourced metrics, where open access creates opportunities for a more competitive market provision of metrics;
- In improved evaluation from either improved peer review or metrics, leading to better funding decisions and more efficient and effective allocation of available funding, thereby helping to maximise the impact of that funding; and
- In lobbying for and obtaining funds, through increased awareness of research outcomes in industry, government and the wider community where results are more easily and openly available, contributing to greater willingness to fund and increased inward funding and/or reduced agency costs in obtaining support.

### The flow of funds

In addition to these possible costs and benefits, impacts on funding flows within research funding activities would be likely to revolve around:

- The use of a small percentage of grants funding to meet publishing fees (*e.g.* author-pays fees), and the implied marginal reduction of research funds, etc.;
- Possible reduced costs of research (*e.g.* reduced institutional overhead costs) *if* toll access costs fall (independently and/or through substitution), or researchers' search, discovery and access costs fall, etc.; and
- Possible increased funding coming in as enhanced access to the results of past research makes the funding agency more visible to the wider community and better able to articulate a value-proposition and lobby for funds. This would also apply to research organisation and contract research funds obtained directly from a funder.

## 2.2 Perform research and communicate the results

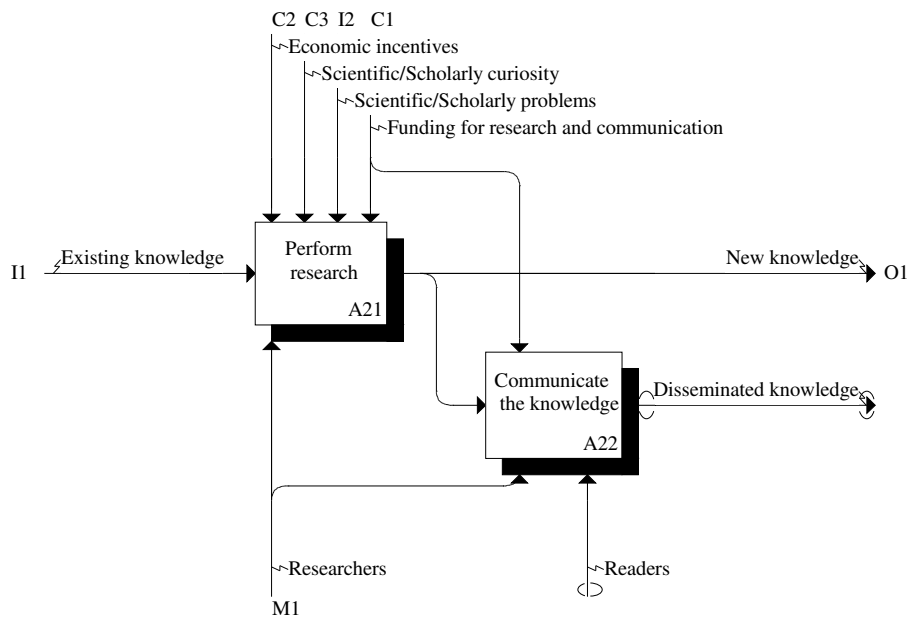
At the heart of the scholarly communication system are the activities of performing research and communicating the knowledge (Figure A2).

These activities are generic, with few national differences beyond those relating to organisational and institutional settings. Funding enters as a control from the activities of *funding research and communication* (A1 above), and the submission of the prepared manuscript or dataset marks the point at which the output passes to the activities of *publishing scientific and scholarly works* (A3 below).

Existing scientific or research-based scholarly knowledge is the principal input and starting point, with research activities shaped by scientific or scholarly curiosity, existing problems and economic incentives, and constrained by available funding. New knowledge is created and disseminated.



Figure A2: Perform research and communicate results



Link: <http://www.cfses.com/EI-ASPM/SCLCM-V7/>

Source: Scholarly Communication Process Model: Authors' analysis.

### 2.2.1 Processes involved in performing research and communicating results

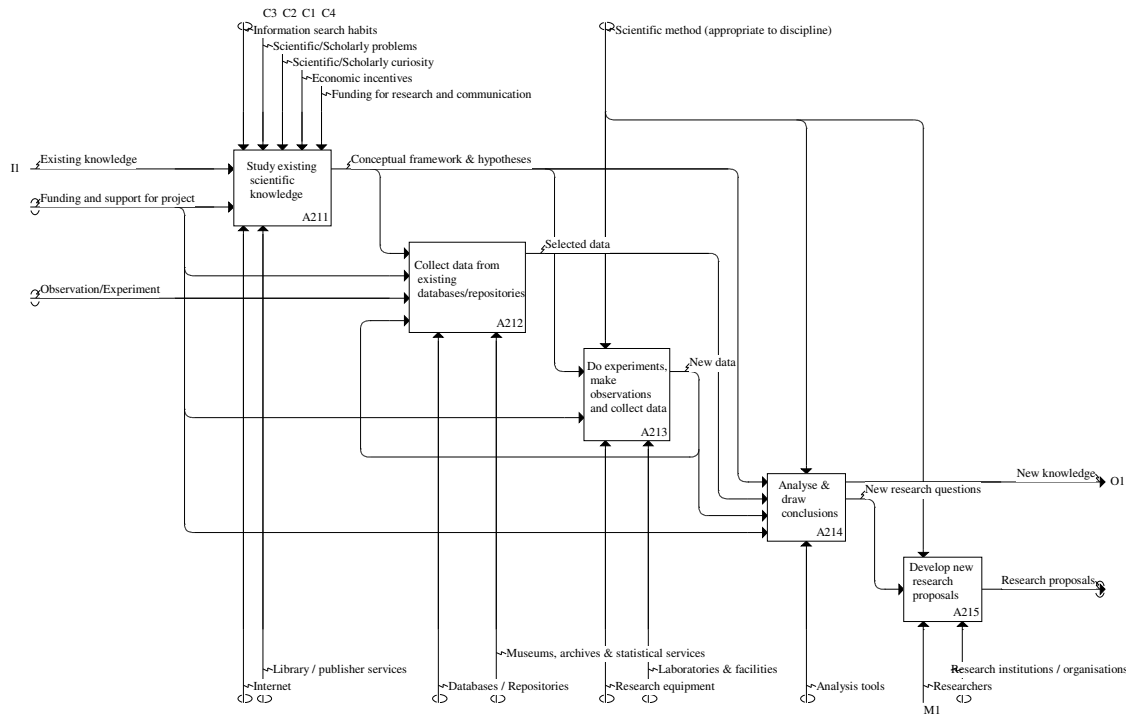
**A21: The performance of research** lies at the core. Extending the model outlined by Björk (2007), it is conceived as involving five main activities, namely: studying existing knowledge; obtaining data from existing databases and repositories; doing experiments, making observations and collecting information (depending on the field of research concerned); analysing and drawing conclusions; and developing new research proposals (Figure A21).

A boundary is set between activities relating to *performing research* and *studying and applying knowledge* (see below at A5) because research is not a closed loop – while research builds on past research and researchers are both producers and consumers of scholarly works, they are by no means the only consumers, with many professionals and practitioners, firms, government agencies and non-government organisations also making use of scientific and scholarly observations, data and publications.

In addition to funding for research and communication (see above), research activities also depend on support and funding from the researchers' supporting institutions for the administrative and support functions, general and research infrastructure and equipment, etc. (*e.g.* through university block grants). Research activities are constrained by scientific/scholarly problems and curiosity, the scientific or scholarly method applicable to the discipline or field of research, be it quantitative or qualitative, and information search and research habits. Activities generate hypotheses, new observations and data, new knowledge and new proposals for further

research, and are enabled by such mechanisms as library, publisher and other intermediary services, databases and repositories, the Internet, museums, archives and statistical services, research equipment, laboratories, facilities and analysis tools.

Figure A21: Perform research

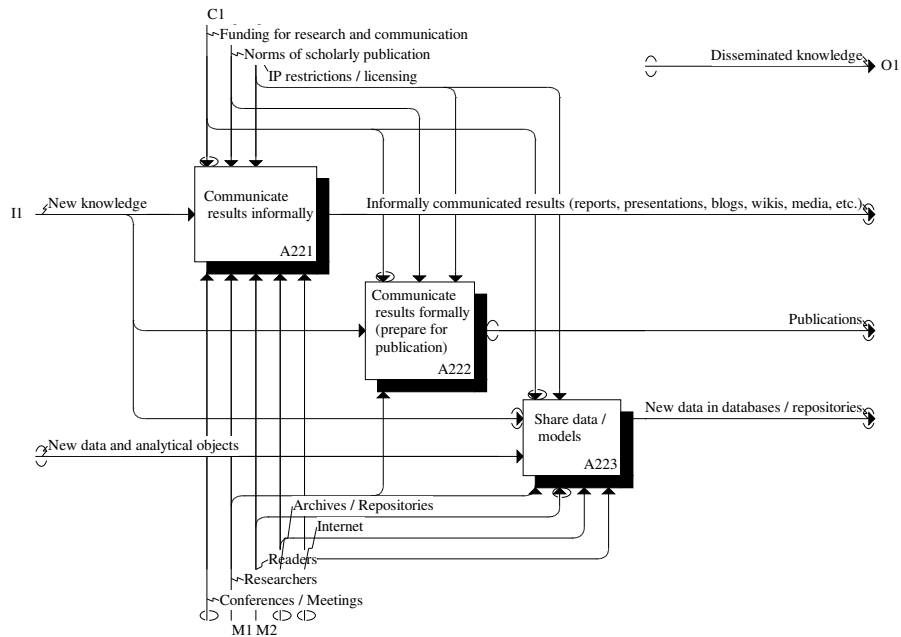


Link: <http://www.cfses.com/EI-ASPM/SCLCM-V7/>

Source: Scholarly Communication Process Model: Authors' analysis.

**A22: Communicating the knowledge** generated is an integral part of performing research. Communicating the knowledge generated can involve communicating results informally or formally (*e.g.* through publication) and through the sharing of data, models, etc. depending in part on the subject and field of research (Figure A22). New knowledge, new data and other analytical objects can be communicated through publication, contributions to conferences and presentations, reports, blogs, wikis and the media, and the deposit of new data or other objects (*e.g.* software, gene sequences, etc.) in databases and repositories, subject to the limitations of funding, IP and licensing restrictions. These activities are facilitated by conferences and meetings, the Internet, archives and repositories, and so on.

Figure A22: Communicate the knowledge

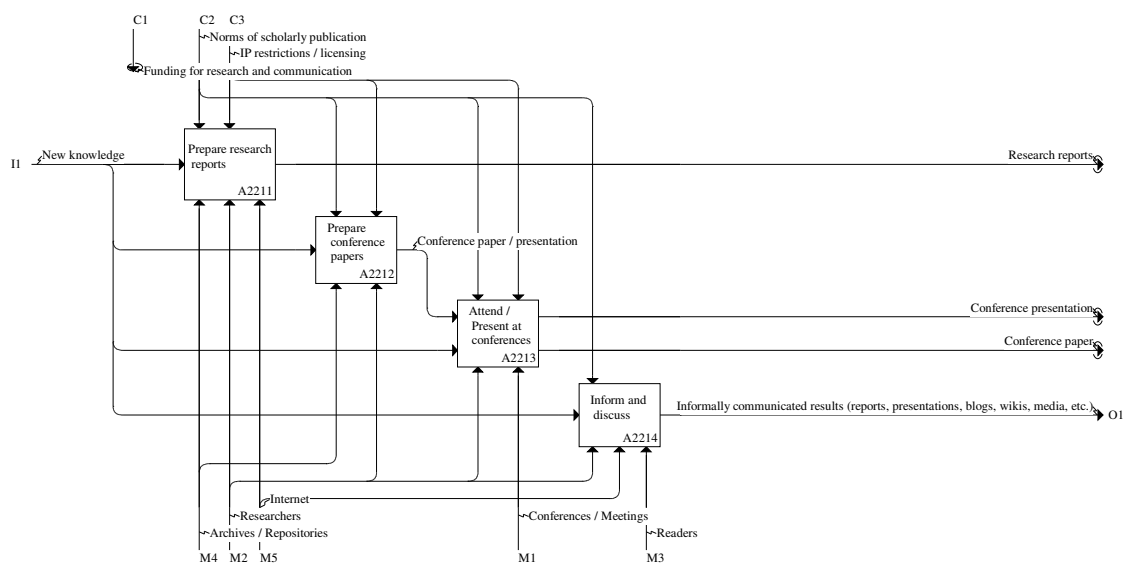


Link: <http://www.cfses.com/EI-ASPM/SCLCM-V7/>

Source: Scholarly Communication Process Model: Authors' analysis.

**A221: Communicating the results informally** involves the preparation of research reports or conference papers and presentations, attending conferences and participation in discussions (Figure A221). These activities are constrained by the norms of scholarly communication and by IP and licensing restrictions (*e.g.* relating to permissions to use the elements of cited works).

Figure A221: Communicate results informally



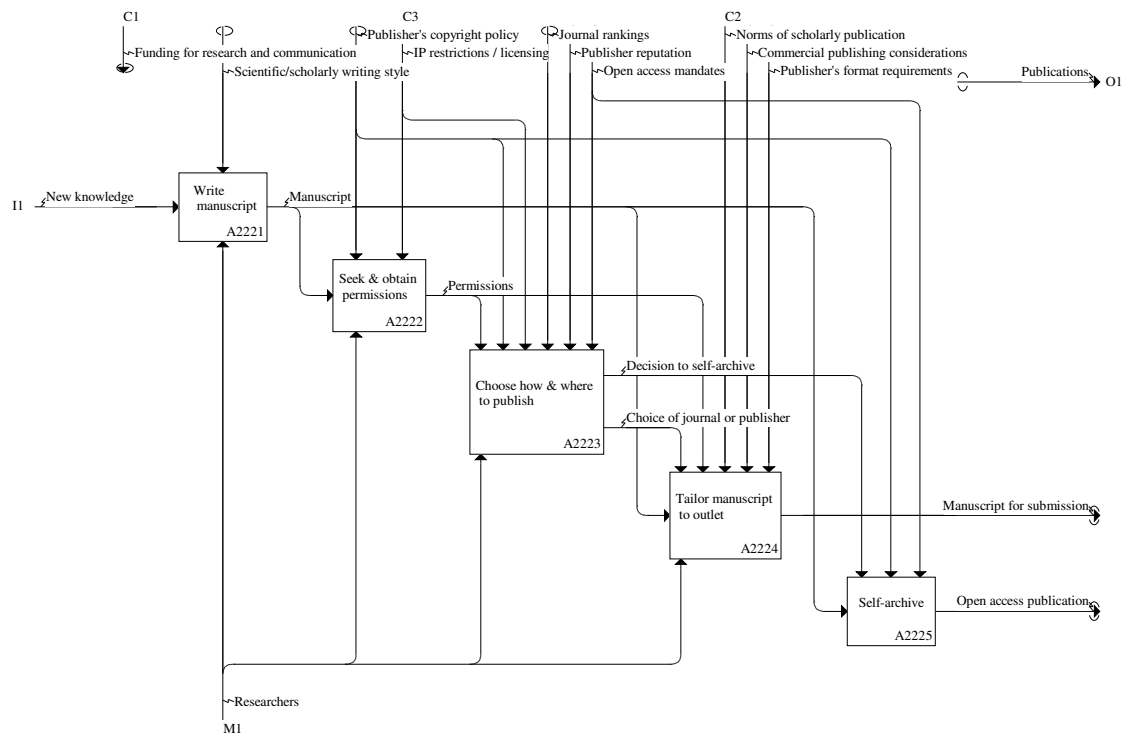
Link: <http://www.cfses.com/EI-ASPM/SCLCM-V7/>

Source: Scholarly Communication Process Model: Authors' analysis.

**A222: Communicating the results formally (i.e. preparing for publication)** includes those researcher activities involved in the preparation of a manuscript up to the point of submission (Figure A222), including:

- Writing the manuscript, constrained by the ‘scientific/scholarly writing style’;
- Seeking and obtaining permissions required, constrained by copyright policies, IP and licensing restrictions;
- Choosing how and where to publish, constrained by copyright policies, IP and licensing restrictions, OA mandates, journal rankings, publisher reputation, etc.;
- Self-archiving, constrained by OA mandates and the copyright policy; and
- Tailoring the manuscript for the chosen outlet, constrained by the norms of scientific/scholarly publication, specific publisher format requirements and commercial publishing considerations.

Figure A222: Communicate results formally (prepare for publication)



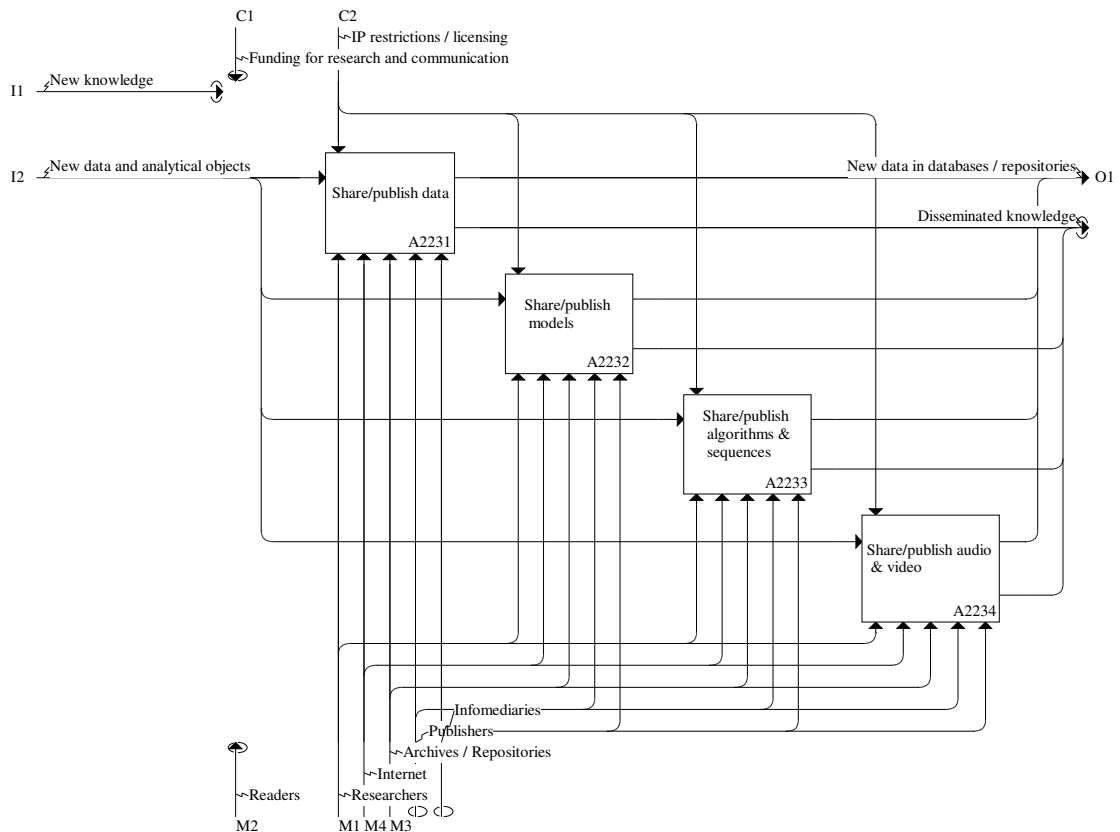
Link: <http://www.cfses.com/EI-ASPM/SCLCM-V7/>

Source: Scholarly Communication Process Model: Authors' analysis.

**A223: Sharing data, models and other digital analytical objects** is becoming an increasingly important part of research and scholarly communication (Figure A223). Example activities include the sharing/publishing of data, models, algorithms and sequences, audio and video, which is constrained by IP and licensing restrictions and depends on such mechanisms as

archives and repositories, the Internet, publishers and infomediaries and the underlying e-science infrastructure.

Figure A223: Share data / models



Link: <http://www.cfses.com/EI-ASPM/SCLCM-V7/>

Source: Scholarly Communication Process Model: Authors' analysis.

### 2.2.2 Identification of the costs involved in performing research and communicating results

R&D expenditures are regularly and widely tracked in most countries around the world in more or less standardised form (*i.e.* following the Frascati Manual). These expenditure are significant, with an estimated USD 772 billion spent in OECD countries in 2005 (around 2.25% of overall GDP), with the combined university and government sectors performing around 30% of the total (OECD 2007). The UK's gross expenditure on R&D reached £23 billion during 2006, of which the government and higher education sectors and research councils accounted for one-third (NSO 2007).

National statistics of this nature are rather aggregate, showing the sectors of funding and performance, expenditure and person years expended on R&D, with some expenditures broken down to show type and direction (*e.g.* costs of facilities and equipment, capital and recurrent,

human resources, etc.). Relatively few analysts have reported in detail on the costs involved in performing various research activities relating to scientific and scholarly communication, with the foundational works in the field being those of Fritz Machlup, Donald King and Carol Tenopir, with others largely drawing on, updating and extending their work.

Reviews of the literature on the costs involved in performing research and communicating the results, and identification of those costs, have been presented in:

- Halliday, L. and Oppenheim, C. (1999) *Economic Models of the Digital Library*, eLib, United Kingdom Office of Library and Information Networking.
- Tenopir, C. and King, D.W. (2000) *Towards electronic journals: realities for scientists, librarians and publishers*, SLA Publishing, Washington DC. and elsewhere.
- EPS, *et al.* (2006) *UK scholarly journals: 2006 baseline report – An evidence-based analysis of data concerning scholarly journal publishing*, Research Information Network, Research Councils UK and Department of Trade and Industry.
- Houghton, J.W. Steele, C. and Sheehan, P.J. (2006) *Research Communication Costs in Australia, Emerging Opportunities and Benefits*, Department of Education, Science and Training, Canberra.
- Björk, B-C. (2007) 'A model of scientific communication as a global distributed information system,' *Information Research* 12(2) paper 307.

Tenopir and King (2000) found that scientists spent more than half their time in communication related activities, with reading, writing and other outputs (*e.g.* conference presentations) accounting for the lion's share. Their mid to late 1990s US surveys found that university-based scientists spent an average 85 hours writing a journal article, or 187 hours per year, while non-university scientists spent an average of 100 hours writing an article, or 10 hours per year (taking longer, but writing far fewer articles). Indeed, they suggested that 75% of all journal articles were written by university-based scientists. Across a range of surveys, time spent authoring a journal article was found to range from 80 to 100 hours, and the total cost of writing, reworking and resubmission was estimated at USD 6,000 (in 1998).

Tenopir and King (2000) also found a range of reading activity across university-based and non-university scientists, with university scientists each reading an average of 188 scholarly journal articles, 48 books and 134 other items per year. They noted that university-based scientists spent an average 58 minutes reading a journal article (182 hours per year), while non-university scientists spent 50 minutes doing so (88 hours per year). By 2003, university scientists' reading had increased to an average of 216 articles per year (Tenopir 2005).

King and Tenopir (2004) suggested that the entire science journal system cost the United States around USD 45 billion a year in human, system, equipment, facilities and other resources (excluding transfer costs). The largest contributor was researcher time, which accounted for 88% of total costs – 10% as authors and 78% as readers.

Houghton *et al.* (2006) presented an extensive review of the literature relating to costs associated with research and research communication activities, and used it as a basis for

activity cost estimates. Their analysis included costs associated with reading, writing and peer review of journals, books and book chapters, journal editor and editorial board activities, and the preparation and review of research grant applications. They also included costs relating to key scholarly communication-related infrastructure, including research libraries' acquisition and non-acquisition costs, higher education network and IT systems and services, archive and repository establishment and operational costs, publishing and publisher costs relating to journals and books.

Table 2.2 presents a summary of the major cost items identified, based on the process model outlined above and a brief review of the literature. The quantification of these costs is the topic of Part II of this report.

**Table 2.2: Perform research and communicate results: major cost items**

| <i>Activity/Item</i>                               | <i>Description</i>  |
|--|---|
| <b>Perform research:</b>                           |   |
| Search and discovery                               | Time spent searching and discovering publications, and the systems supports required.   |
| Access and download                                | Time spent, systems and any direct access costs borne by the researcher or research institution.  |
| Reading (incl. reading in order to write)          | Time spent studying material needed.  |
| Rights and permissions (to use)                    | Time, etc. spent gaining permissions to use material in teaching or research ( <i>e.g.</i> course-packs, text analysis, etc.).  |
| Experiments, observation and information gathering | Time spent designing and developing experiments, surveys, etc., and in their operation, conduct and recording, in gathering information, etc.   |
| Analysis   | Time spent analysing results and drawing conclusions.   |
| Project management and operations                  | Time spent in project management, collaboration management, project operations relating to funding, reporting, etc. not covered by evaluation directly.   |
| <b>Research infrastructure:</b>                    |   |
| Library and information                            | Costs associated with library and information content and infrastructure.   |
| Laboratories, facilities and equipment             | Costs associated with establishment, maintenance and operation of laboratories, facilities and equipment.   |
| IT systems and grid                                | Costs associated with operation of IT systems and grid.   |
| Overheads of institutions                          | Costs associated with operation of research institutions and administration.  |
| <b>Communicate research:</b>                       |   |
| Writing, preparation and participation             | Time, systems and direct costs associated with writing, preparation and participation of all forms of informal communication ( <i>e.g.</i> including research reports, conference papers and presentations, discussion lists, meetings, blogs, etc. with each identified where possible). |
| Sharing data, models, etc.                         | Time spent on research activities that are a part of the creation of intermediate outputs ( <i>e.g.</i> data, models, software, etc.).  |
| Preparation of formal publications                 | Time, systems and direct costs associated with writing and preparation of formal publications ( <i>e.g.</i> journal articles, books, etc. with each identified where possible).   |

Cont'd.



| <i>Activity/Item</i>                                 | <i>Description</i>   |
|--|--|
| Self-archiving                                       | Time and costs associated with author self-archiving, if done.   |
| Submission, formatting and revision                  | Time, systems and other costs associated with formatting for specific publisher requirements, submission process and recording, responses and revisions to reviewer and/or editor comments, etc.   |
| Checking rights and permissions                      | Negotiating and agreeing with publishers for the use of cited materials, and relating to self-archiving (if done).   |
| Licensing and copyright agreements                   | Negotiating and agreeing with publishers for own authored works.   |
| <b>Publishing-related activities of researchers:</b> |  |
| Editorial  | Time, systems and other costs associated with acting as an editor (journal, book series, conference, working paper series, etc.).  |
| Editorial board                                      | Time, systems and other costs associated with being on a journal's editorial board.  |
| Peer review (publishing)                             | Time, systems and other costs associated with undertaking peer reviews for works submitted for publication (journal articles, conference papers, books, etc.), but excluding the reviewing of grant applications and research proposals. |
| Book review and news content                         | Time, systems and other costs associated with producing reviews and other non-article content used in publications ( <i>e.g.</i> book reviews, etc).   |

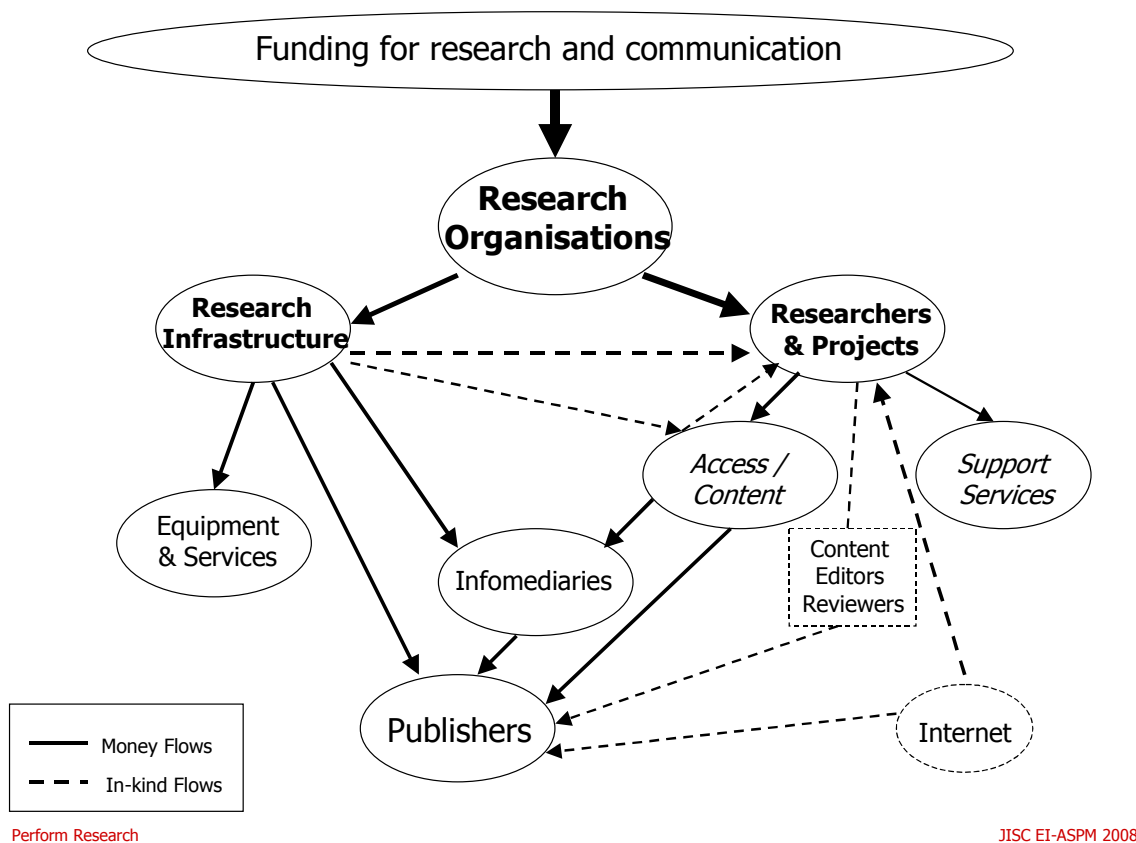
Source: Authors' analysis.

### 2.2.3 Funding flows relating to performing research

Funding flows relating to the performance of research are more complex than those relating to its funding, although on the input side research funding comes from a relative small number of major sources, including governments directly or through arms-length funding and research councils, foundations and industry (Figure 2.2). A major distinction is that between project funding and institutional funding or block grants, with the latter covering a wider range of less easily attributable infrastructure and organisational expenses.

The bulk of the research funding is used to pay for the time of the researchers involved, the equipment and facilities used, specialist IT systems and equipment, and the input data and publications used. There are also substantial expenditures on more generic infrastructure (*e.g.* libraries, IT systems, the Internet, etc.). A wide range of smaller items are also involved, with specialist and non-specialist services and service providers also sharing some of the funds through their support of conferences and meetings, information services and generic institutional services.

Figure 2.2: Simplified funding flows relating to performing research



Source: Authors' analysis.

### 2.2.4 The impacts of alternative publishing models on research and communication activities

There are a number of points at which differences in the operation of alternative scholarly publishing models may affect these activities and, thereby, the costs, benefits and funding flows involved in performing research and communicating results.

#### Costs and impacts

The main areas of impact on research costs include:

- The availability of funds to meet author-side publishing fees (*e.g.* for author-pays OA publishing), with many fields of research in humanities and social sciences being conducted with limited funding, and early career and independent scholars and students often having no funding support;
- The costs of access to existing published knowledge, where overall costs may change and/or shift from reader-side to author-side, or involve proliferation and greater variety of payment systems;

## Economic implications of alternative scholarly publishing models

- The cost and efficiency implications of the researchers' ability to openly and freely access any and all published work as required by the direction of the research (*e.g.* being unaware of past work leading to duplicative work, the pursuit of blind alleys, failure to adopt the latest techniques, etc.);
- The costs of access to existing data, models, software, etc. and the cost and efficiency implications of having to re-collect, re-codify, re-enter and store anew that to which access is not granted (not to mention the cost to society of repeating surveys, social or psychological experiments, drug tests, etc.);
- The costs of search and discovery, where they are affected by publishing business models (*e.g.* where proprietary access systems operate differently and impose use and switching costs, where proprietary access systems limit cross-platform searching and/or retrieval, where variations in IP and licensing restrictions create uncertainty and take time to investigate, etc.);
- The costs associated with a relative lack of integration of the published findings and the supporting data and analysis tools required for research, be they due to IP and licensing constraints, technical limitations or the separation of the publishing processes for text and non-text objects; and
- The costs, including opportunity costs, imposed by IP and licensing restrictions preventing certain forms of research analysis (*e.g.* preventing downloading and text mining substantial sections of the research literature in a certain field).

The main areas of research communication cost impact include:

- The costs that copyright policy and IP and licensing restrictions impose in seeking permissions to use the materials cited;
- The costs imposed by copyright policies that limit the author(s) ability to distribute, communicate and re-use their own work (*e.g.* for use in teaching);
- The costs associated with tailoring a manuscript to a particular publisher's format requirements ('House Style'); and
- The costs associated with multiple proprietary access and authentication systems.

## The flow of funds

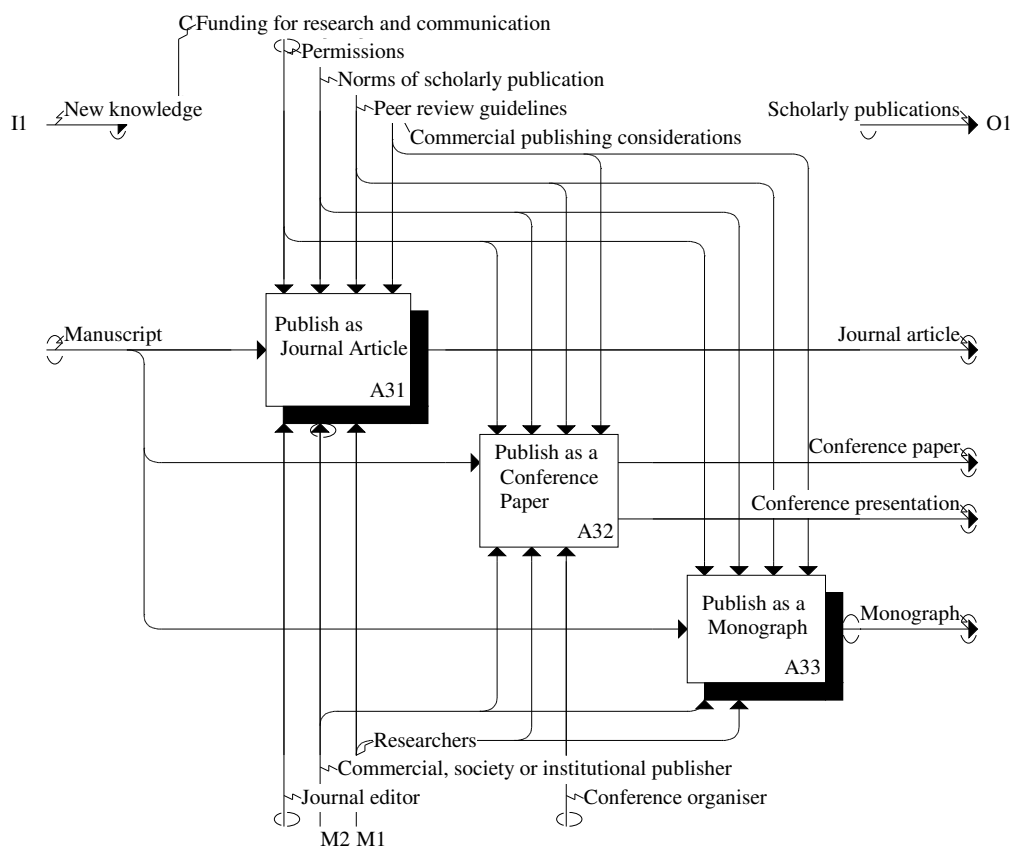
In addition to these possible costs and benefits, impacts on funding flows within research activities would be likely to revolve around:

- Possible differences in the use of research time and funding (*e.g.* in applying for and obtaining permissions versus self-archiving to a subject or institutional repository, etc.); and
- Possible reduction of publisher costs relating to the use of more open and simpler IP and licensing practices (*e.g.* not having to process requests for permissions, field enquiries about license conditions, etc.).

## 2.3 Publish scientific and scholarly works

Publishing scientific and scholarly works (*i.e.* formal publishing) is a crucial step, making the results of research available to users, establishing priority for the research and researcher(s), and giving the work a stamp of authenticity and quality through the peer review process – be it through publication as a journal article (with or without associated data (Piwowar 2008), a research monograph (book) or a formal conference paper (Figure A3).<sup>21</sup>

Figure A3: Publish scientific / scholarly works



Link: <http://www.cfses.com/EI-ASPM/SCLCM-V7/>

Source: Scholarly Communication Process Model: Authors' analysis.

Publishing activities start with the submission of a manuscript for review and end with the production and distribution of the article, book, conference paper, etc.; and they involve researchers, book and journal editors and editorial boards, reviewers, commercial, society and institutional publishers, and conference organisers, among others. Activities are constrained by funding, the norms of scholarly publication, and a range of scholarly and commercial publishing considerations.

<sup>21</sup> A distinction between informal and formal publishing is drawn around the issues of editorial independence and peer or expert editorial review, with formal publishing characterised by editorial independence and review.

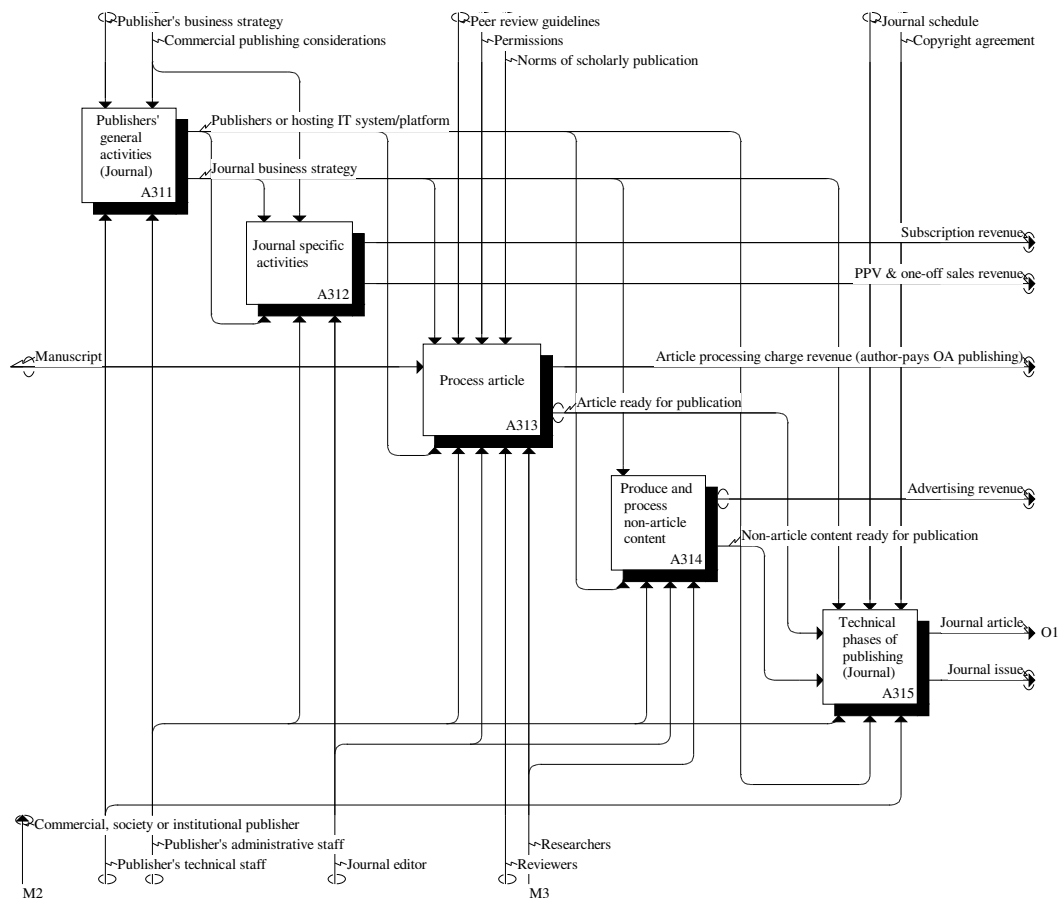
### 2.3.1 Processes involved in publishing scientific and scholarly works

The processes involved in publishing scientific and scholarly works are complex, differing for each of the major forms of published works. There is some variation between publishers (*e.g.* some journal publishers review manuscripts internally before sending them out for review, while others do not; and some choose not to copyedit, while others do so (EPS *et al.* 2006, p46)); and, of course, there is variation between publishing models. However, scholarly publishing is a global activity exhibiting relatively few national differences.

#### Publish as a journal article

**A31: Publishing scholarly work in a journal article** is the most important form of publishing in many if not most research fields. It is also the most complex of the publishing processes, involving a range of actors and activities in a multi-stage process. Extending the model outlined by Björk (2007), key activities include a range of general publisher activities required of journal publishers, journal specific activities, article processing and non-article content processing activities (Figure A31). Each is described in detail.

Figure A31: Publish as a journal article

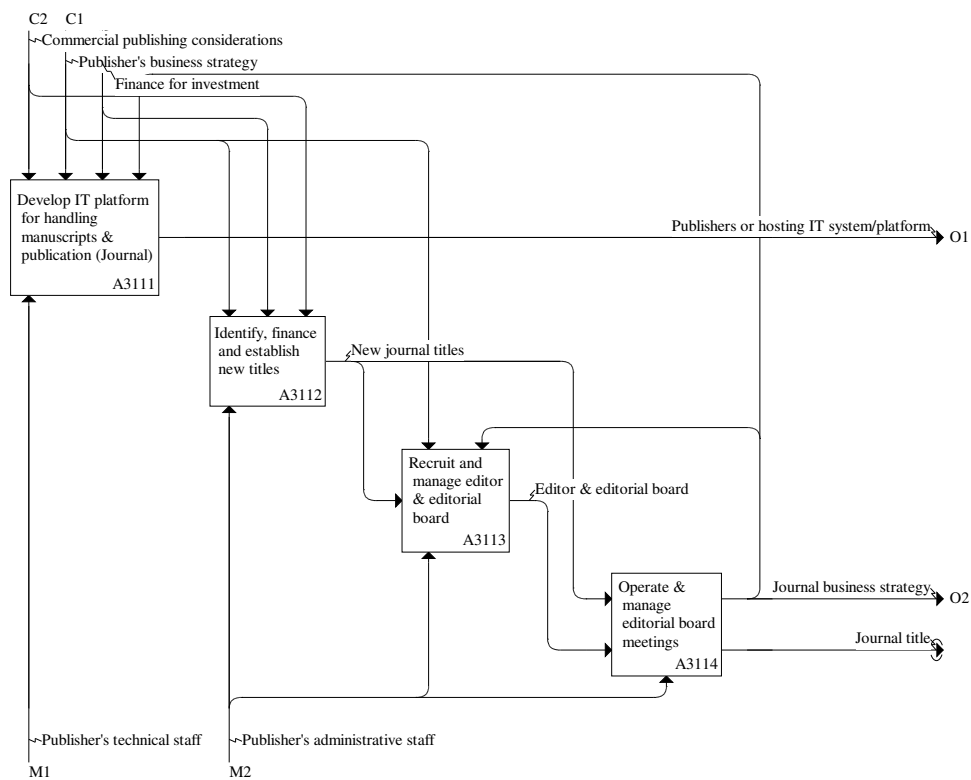


Link: <http://www.cfes.com/EI-ASPM/SCLCM-V7/>

Source: Scholarly Communication Process Model: Authors' analysis.

**A311: General journal publisher activities** include: developing and operating the IT platform for handling manuscripts and publication (or a manual process and record keeping system for a physical handling process); identifying, financing and establishing new journals (titles); recruiting, supporting and managing the editor and editorial board's activities; and facilitating and managing editorial board meetings (Figure A311). Facilitated through the publishers administrative and technical staff, these activities are constrained by commercial publishing considerations and the publishers' business strategies; and they produce the journal title (brand), a journal business strategy for that title, and the IT or manual platform to handle the publication process.

Figure A311: Publishers' general activities (Journal)



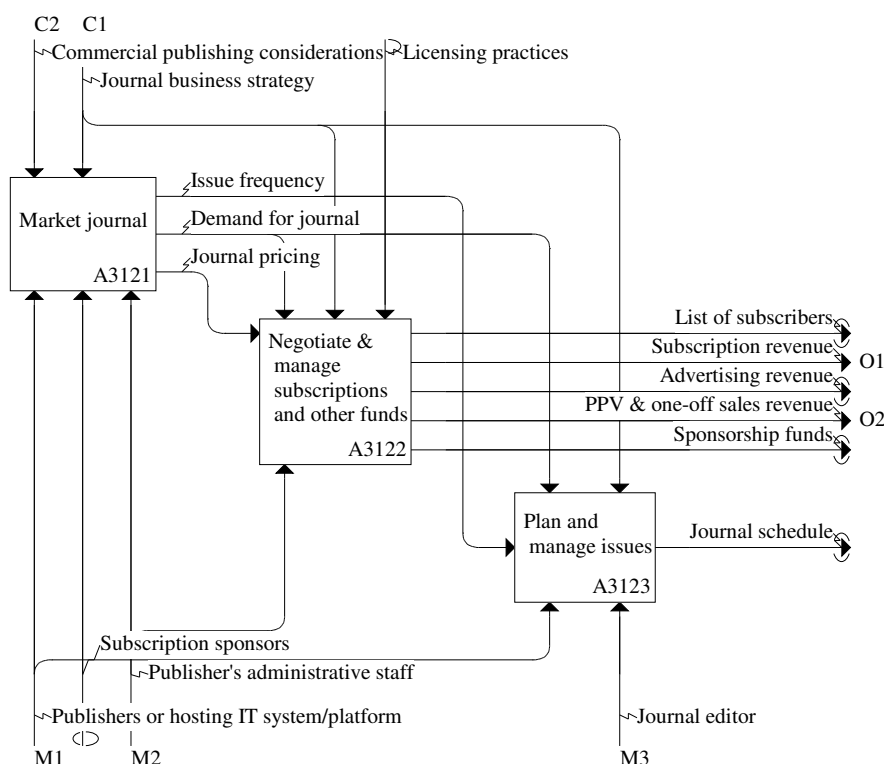
Link: <http://www.cfses.com/EI-ASPM/SCLCM-V7/>

Source: Scholarly Communication Process Model: Authors' analysis.

**A312: Journal (title) specific activities** include: marketing the journal title; negotiating and managing subscriptions (in the toll access model); planning and managing issues (Figure A312). Actors include publishers' administrative and technical staff, journal editors and subscription sponsors. Their activities are constrained by commercial publishing considerations, the journal business strategy and IP and licensing strategies; and they result in the development of demand for the journal, establish journal pricing, a journal schedule and issue frequency, and, in the toll access model, a list of subscribers and subscription revenues. Marketing activities may also

generate pay-per-view and one-off sales, advertising placements and sponsorship funding (depending on the publisher and/or journal business strategies and publishing models).

Figure A312: Journal specific activities



Link: <http://www.cfses.com/EI-ASPM/SCLCM-V7/>

Source: Scholarly Communication Process Model: Authors' analysis.

**A313: Article processing activities** include: article selection, operating the peer review process, negotiating copyright or other licensing rights to the article, and collecting article charges (where applicable) (Figure A313). The arrival of the manuscript triggers the process:

- Subject to the journal guidelines and/or editor's judgement as to suitability (*i.e.* be considered suitable in terms of general topic and/or style, compliance with submission guidelines, and preliminary assessment as to quality) the manuscript may be rejected or enter the peer review process.<sup>22</sup>
- The peer review process is described in more detail below.
- Negotiating copyright or other licensing rights in the article involves publisher administrative staff and researchers in the generation of the 'copyright' agreement, and

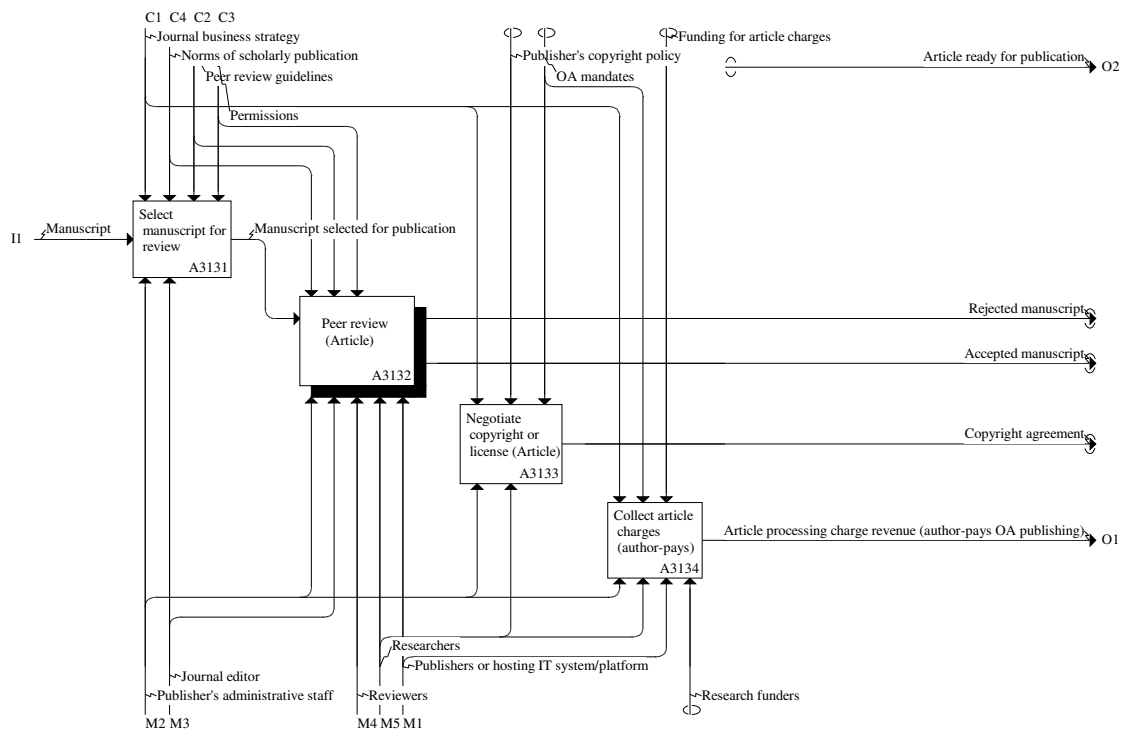
<sup>22</sup> Journal editors can add value in the creation of thematic bundles and selection of material on special topics. However, these also impact on article selection (independent of 'quality' *per se*).



is constrained by the publisher's copyright policy, OA mandates and journal business strategy.

- Collecting article or other publication charges depends on the journal's business strategy and availability of funds to pay publication charges; it involves publisher administrative staff, researchers and research funders in the collection and processing of revenues.

Figure A313: Process article



Link: <http://www.cfses.com/EI-ASPM/SCLCM-V7/>

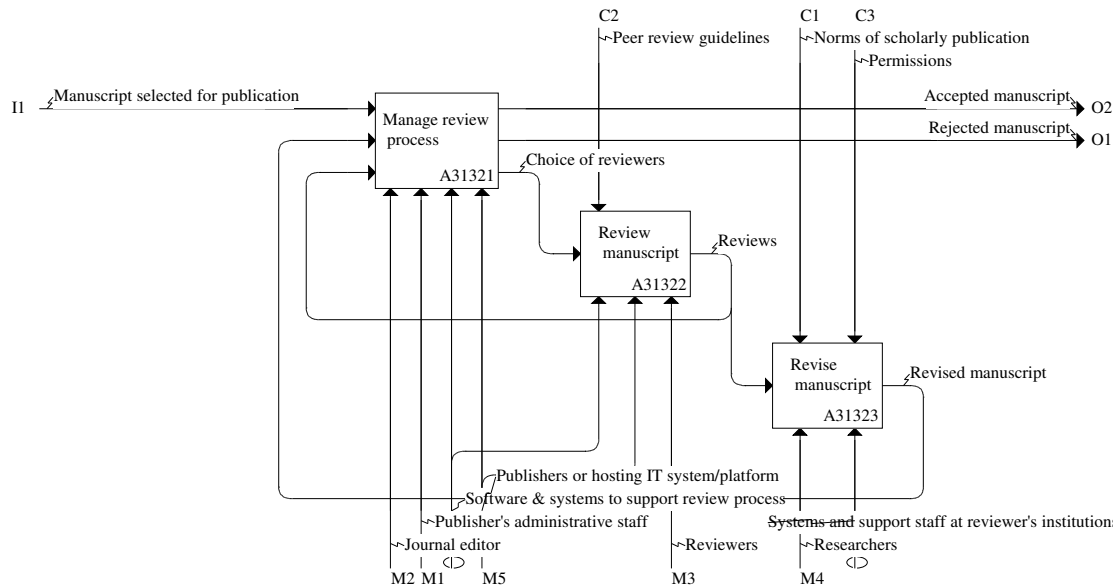
Source: Scholarly Communication Process Model: Authors' analysis.

**A3131: Peer review.** From the publisher point of view, peer review involves managing the review process, reviewing and revising the manuscripts (Figure A3131). The input is the submitted manuscript, the receipt of which triggers the process. It is managed by the journal editor and publisher's administrative staff and supported by the publishers IT (or manual processing) platform and software and systems specific to supporting the review process.

Once the editor and editorial office staff have chosen suitable reviewers, the review process begins. Controlled by the journal/publisher peer review guidelines, the process involves external peer reviewers supported by the journal editor and the publisher's administrative staff, the publishers IT (or manual processing) platform and software and systems specific to supporting the review process, as well as the systems and support staffs and infrastructure at the external reviewers' home institution.

Reviews are fed back to the authors (researchers) for information, typically seeking clarification and/or amendment. The revised manuscript is then fed back into the system and may again be sent to the external reviewers to check that suitable revisions have been made. Subject to agreement among editor and reviewers the article is then accepted (or rejected).

Figure A3132: Peer review (Article)



Link: <http://www.cfes.com/EI-ASPM/SCLCM-V7/>

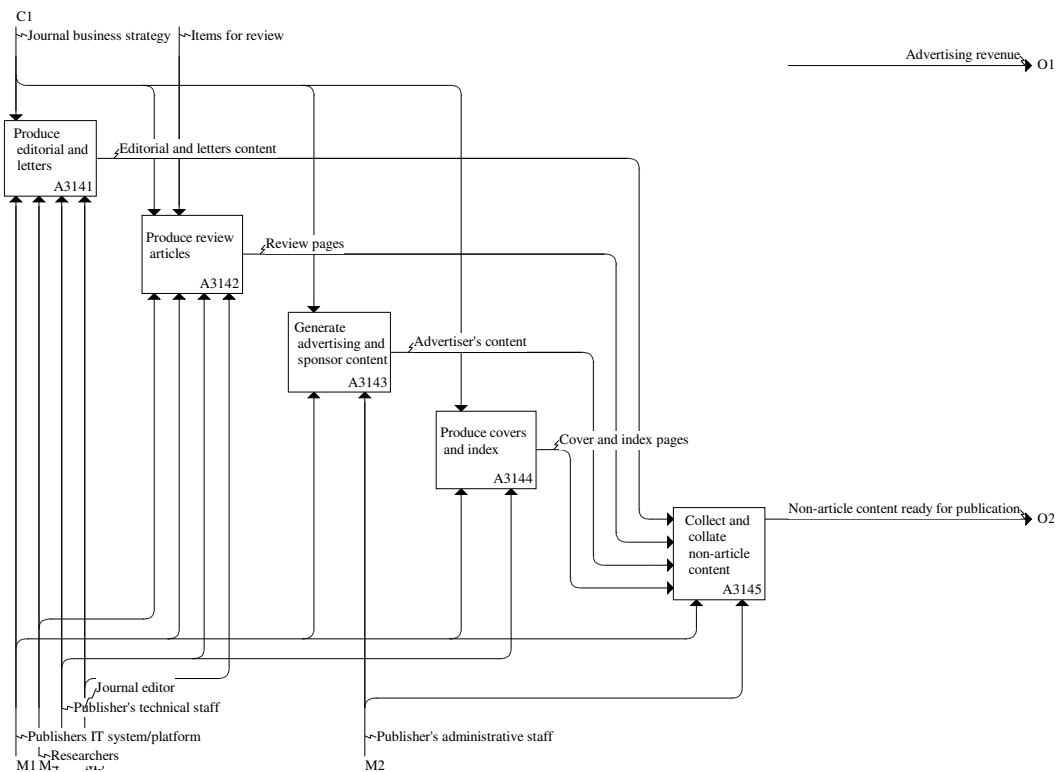
Source: Scholarly Communication Process Model: Authors' analysis.

**A314: Producing and processing non-article journal content** involves both producing and processing the editorial, letters, review articles, advertising and sponsor content, as well as covers and indexes (Figure A314).

The production and processing of editorial, letters and review article content involves the publisher's administrative and technical staff, as well as the contribution of the journal editor and researchers to the letters, (guest) editorial and review article content. Generating advertising and sponsor content, indexes and covers, and processing this content into the journal are publisher activities with no researcher inputs.

Activities are constrained by the journal business strategy and, in the case of producing review articles, by items received for review. Although not shown, the production of review articles may follow a process similar to peer review – with items for review received and send out to reviewers, who then perform the review and write it up in much the same way as they might review an article manuscript (in functional, if not necessarily stylistic terms). Each activity generates non-article content that is collected, collated and made ready for the technical processing phases of publication.

Figure A314: Produce and process non-article content



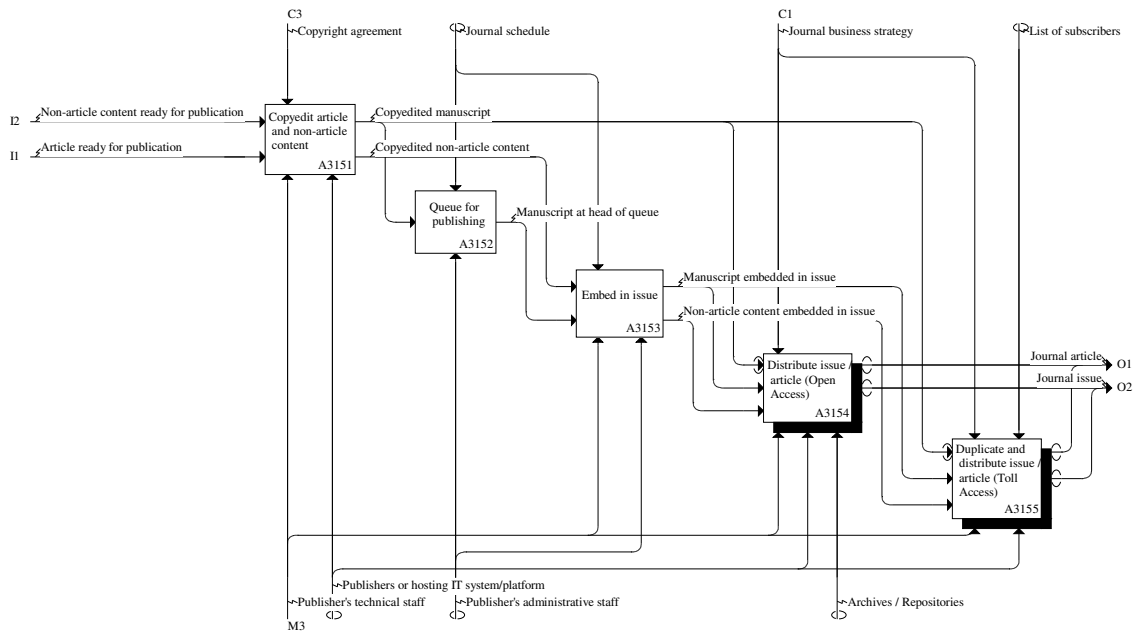
Link: <http://www.cfses.com/EI-ASPM/SCLCM-V7/>

Source: Scholarly Communication Process Model: Authors' analysis.

**A315: The technical phases of journal publishing** include copyediting article and non-article content, queuing for publication and embedding in the issue. The distribution activities vary between publishing models (*i.e.* OA publishing and toll access publishing) (Figure A315).

Publishers' administrative and technical staff, and their IT platforms and/or OA repositories provide the mechanisms for these activities. Constrained by copyright agreements and the journal schedule, and, where applicable, the list of subscribers, content is processed and embedded into the issue.

Figure A315: Technical phases of publishing (Journal)

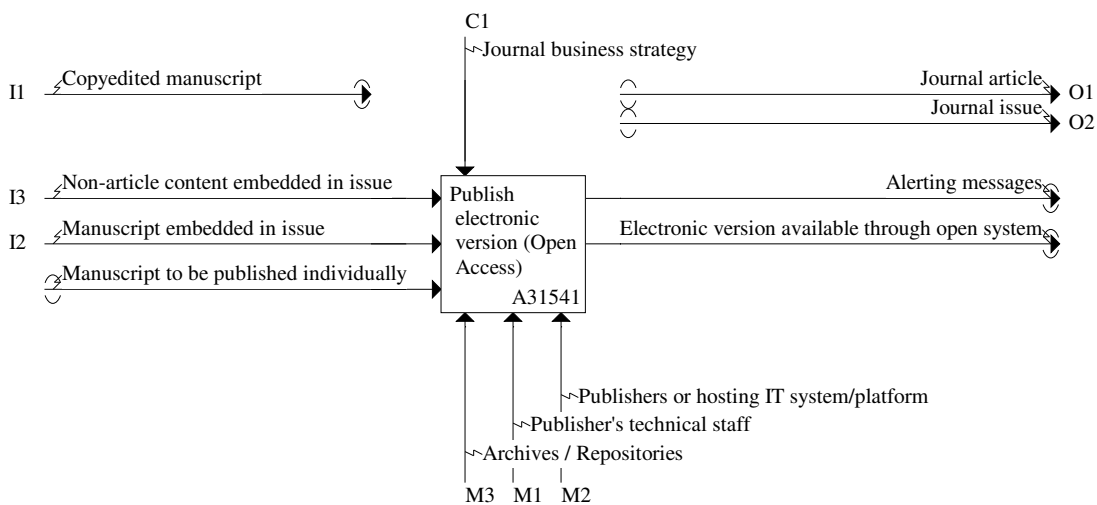


Link: <http://www.cfes.com/EI-ASPM/SCLCM-V7/>

Source: Scholarly Communication Process Model: Authors' analysis.

**A3154: Distributing journals in the OA publishing model** is simpler than it is in the case of toll access publishing, with activities limited to: converting the issue and/or individual article content to suitable formats, attaching DOIs and mounting on an in-house hosting system or passing content to an outsourced hosting services supplier, repository or website; and no need to print and physically distribute, unless print distribution is part of an additional service.

Figure A3154: Distribute issue / article (Open Access)



Link: <http://www.cfes.com/EI-ASPM/SCLCM-V7/>

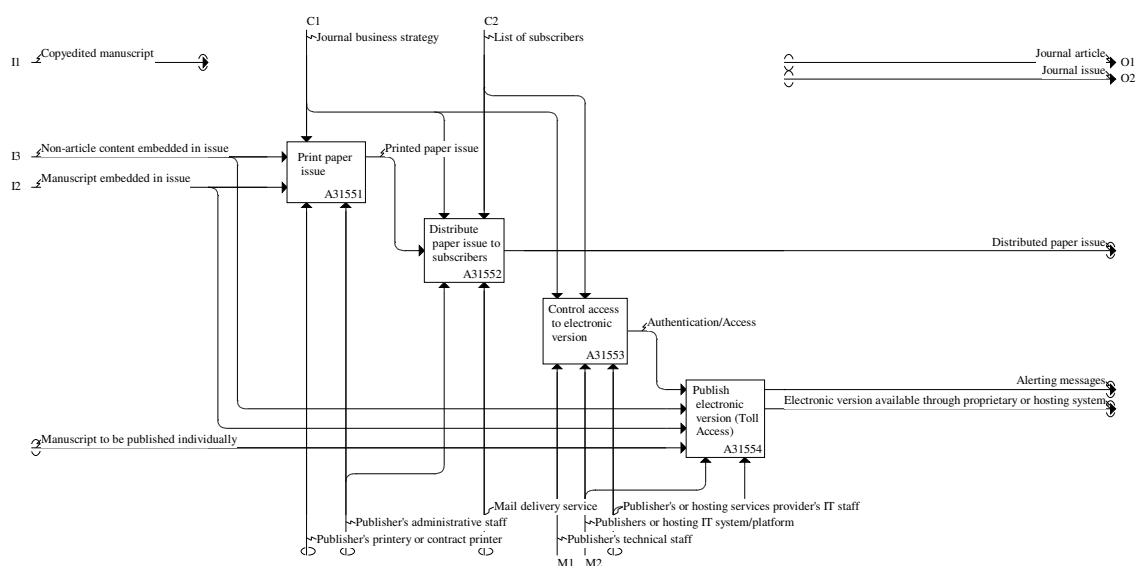
Source: Scholarly Communication Process Model: Authors' analysis.

**A3155: Duplicating and distributing journals in the toll access publishing model** often involves distinct but parallel processes for print and electronic formats (Figure A3154).

The distribution of an *electronic* journal's content involves the publisher's technical staff, IT platform and systems, or those of an outsourced supplier of hosting services, in converting the issue and individual article content to suitable formats, attaching DOIs, and mounting on an internally operated hosting and access control system or passing to an external supplier of access control and hosting services. The access control aspects of hosting apply to the toll access publishing model only.

Printing and distributing a *paper* journal issue involves the publisher's administrative staff, and internal printery or external contract printer in the production, and mail or courier services in the distribution. Distribution activities are constrained by the list of subscribers (in the subscription publishing model only) and/or by individual orders.

Figure A3155: Duplicate and distribute issue / article (Toll Access)



Link: <http://www.cfses.com/EI-ASPM/SCLCM-V7/>

Source: Scholarly Communication Process Model: Authors' analysis.

Regardless of publishing business model, journal publishing also involves the development, recording and sharing of a range of usage metrics, such as hits and full text downloads, which demands the use of reporting standards compliance (e.g. COUNTER compliance) and some resource support for the activities.

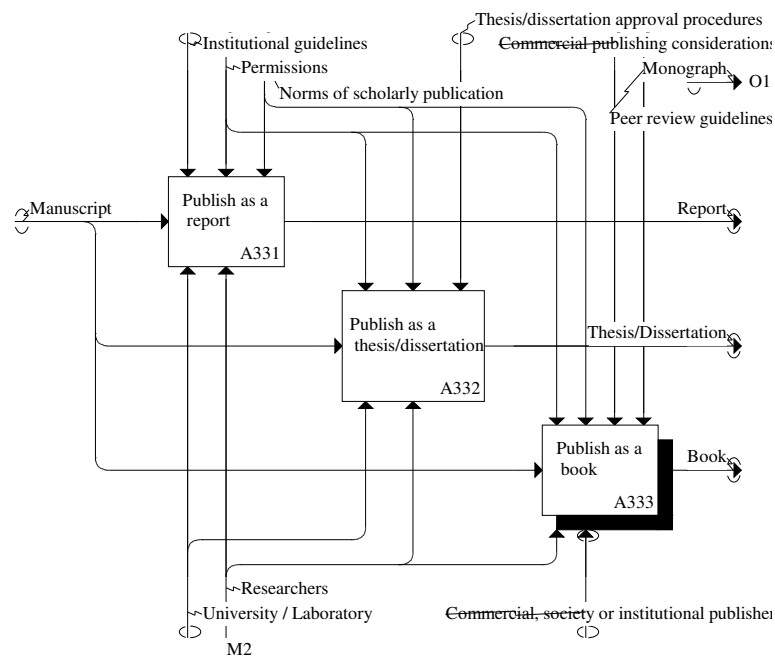
While it is still common for toll access journals to be published in both print and electronic form (dual-mode), OA journals are often e-only and there is an increasing number of e-only toll access journals. Eliminating re-production/duplication, physical handling and distribution costs can make a substantial difference to the overall costs of journal publishing, even though substantial up-front and some considerable recurrent costs are involved in the development and

operation of the publishers' online access systems. However, these too could be reduced by outsourcing hosting services and/or using repositories for distribution (depending on publishing model). OA online access systems that do not require the access control implied by toll access business models can be simpler to develop and operate, journals published outside Big Deal portfolios do not need the branded interface and can make greater use of hosting services and repositories, and OA journal publishers may also feel less need for a branded access interface. Simpler and more generic access systems are also likely to be easier and cheaper to use.

### Publish as a monograph

**A33: Publishing research monographs** follows a broadly similar process, depending on the nature of the material (Figure A33).<sup>23</sup> Nevertheless, whether it be a book a report or thesis/dissertation the process involves researchers and commercial, society or institutional publishers, and their activities are constrained by institutional guidelines, permissions, the norms of scholarly publication, and, in those particular cases, thesis/dissertation approval procedures and peer review guidelines.

Figure A33: Publish as a monograph



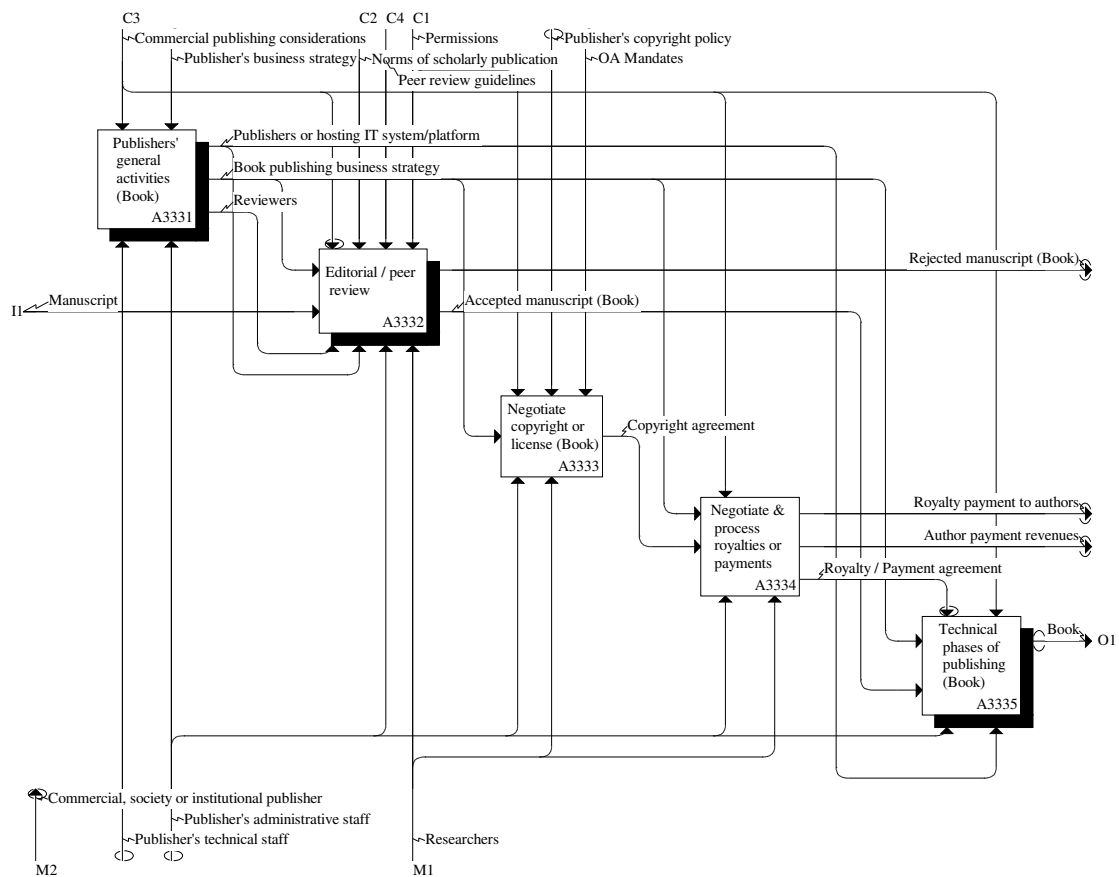
Link: <http://www.cfses.com/EI-ASPM/SCLCM-V7/>

Source: Scholarly Communication Process Model: Authors' analysis.

<sup>23</sup> A monograph is a research work primarily intended for library purchase and use by other researchers. Such works are, typically, relatively low volume.

**A333: Publishing as a book** involves: general publishers' activities, editorial peer review and technical phases of publishing, as well as negotiating copyright or other licensing agreements with the author(s), and negotiating and processing royalties payments (to authors) or payments from authors to publishers (*e.g.* page or plate charges) (Figure A333).

Figure A333: Publish as a book



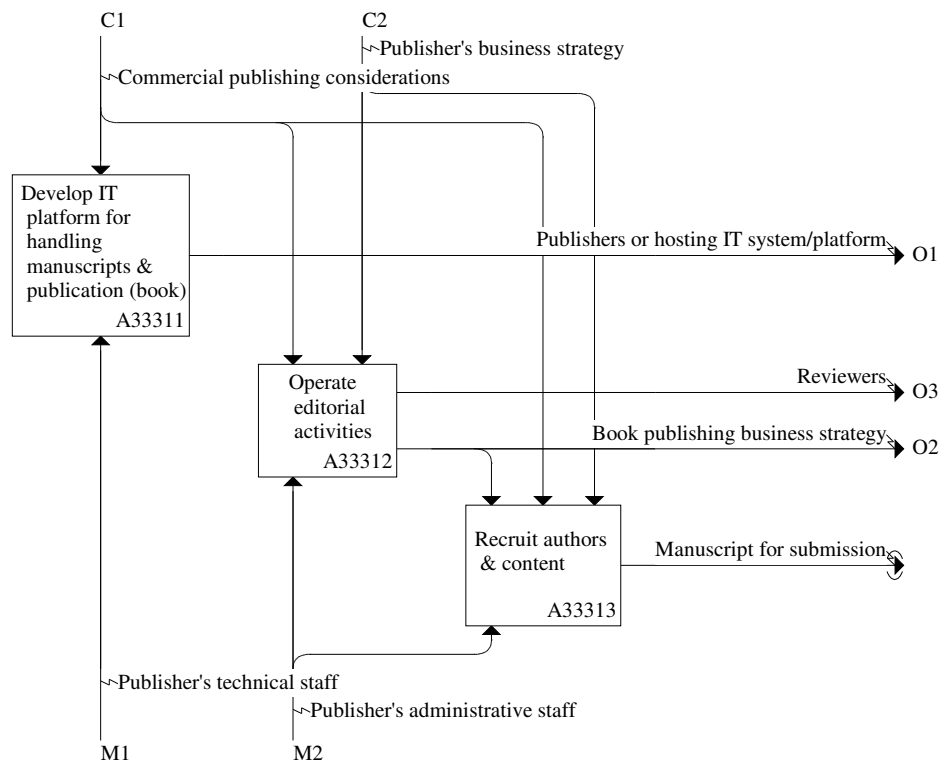
Link: <http://www.cfses.com/EI-ASPM/SCLCM-V7/>

Source: Scholarly Communication Process Model: Authors' analysis.

**A3331: Book publishers' general activities** are similar to those of journal publishers and include: developing and/or implementing the IT platform for handling manuscripts and publication, which involves publishers' technical staff; operating editorial activities; and recruiting authors and content, which involves publishers' administrative staff (Figure A3331). Commercial publishing considerations and the publisher's business strategy set constraints. These activities produce the necessary IT platform (if done internally), define the publisher's book publishing business strategy, and ensure a supply of manuscripts for publication and of reviewers to perform peer review and ensure quality control.



Figure A3331: Publishers' general activities (Book)



Link: <http://www.cfses.com/EI-ASPM/SCLCM-V7/>

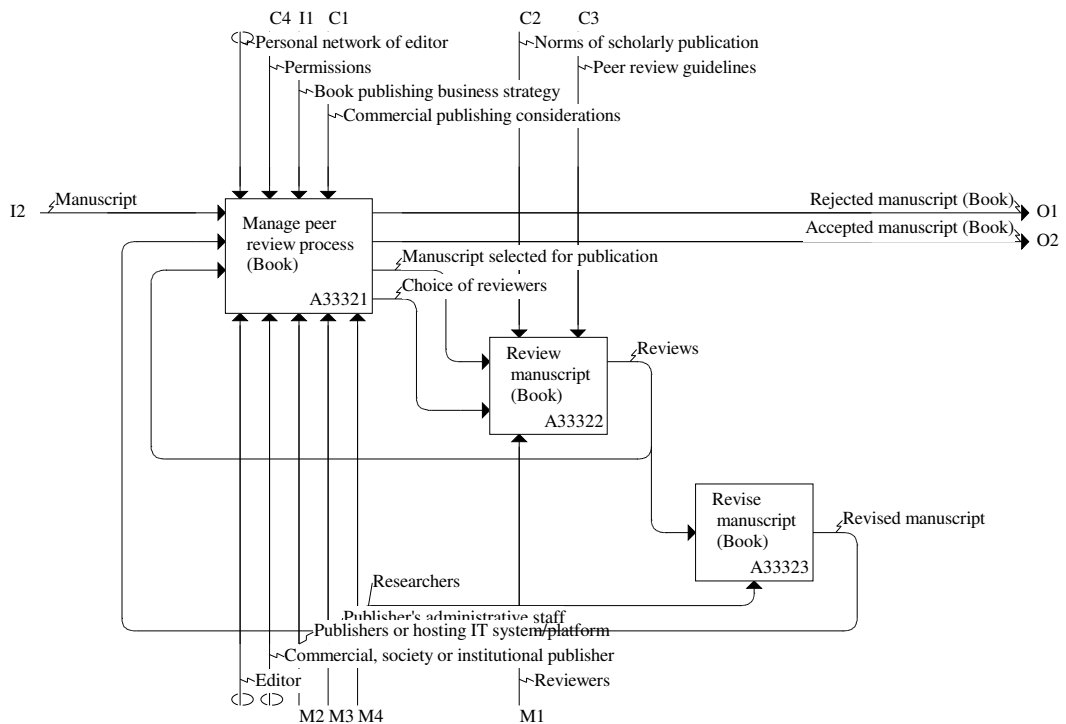
Source: Scholarly Communication Process Model: Authors' analysis.

**A3332: The editorial and peer review process for books** is similar to that used for journal articles, although editors are more likely to be internal to the publisher and there may be fewer external reviewers for each manuscript (Figure A3332).

The arrival of a manuscript triggers the process. Subject to the publisher's book publishing business strategy and commercial publishing considerations, the manuscript may be rejected or enter the review process (*i.e.* be considered suitable in terms of general topic and marketability). Drawing on a personal and/or the publisher's network, the editor will identify and recruit suitable reviewers, while the publisher's administrative staff check that the author(s) have appropriate permissions for materials cited and the author(s) seek and obtain permissions.

The review process involves reviewers reading the manuscript and, guided by the norms of scholarly publishing and the publisher's peer review guidelines, producing their reviews. These may trigger a revision of the manuscript or lead directly to its acceptance or rejection. Authors asked to revise their manuscripts may do so and re-submit into the review process, and depending on whether or not the editor feels that issues raised by reviewers have been dealt with sufficiently may seek a further review of the revised manuscript. Revisions to the manuscript may involve a substantial amount of time and effort on the part of authors and reviewers.

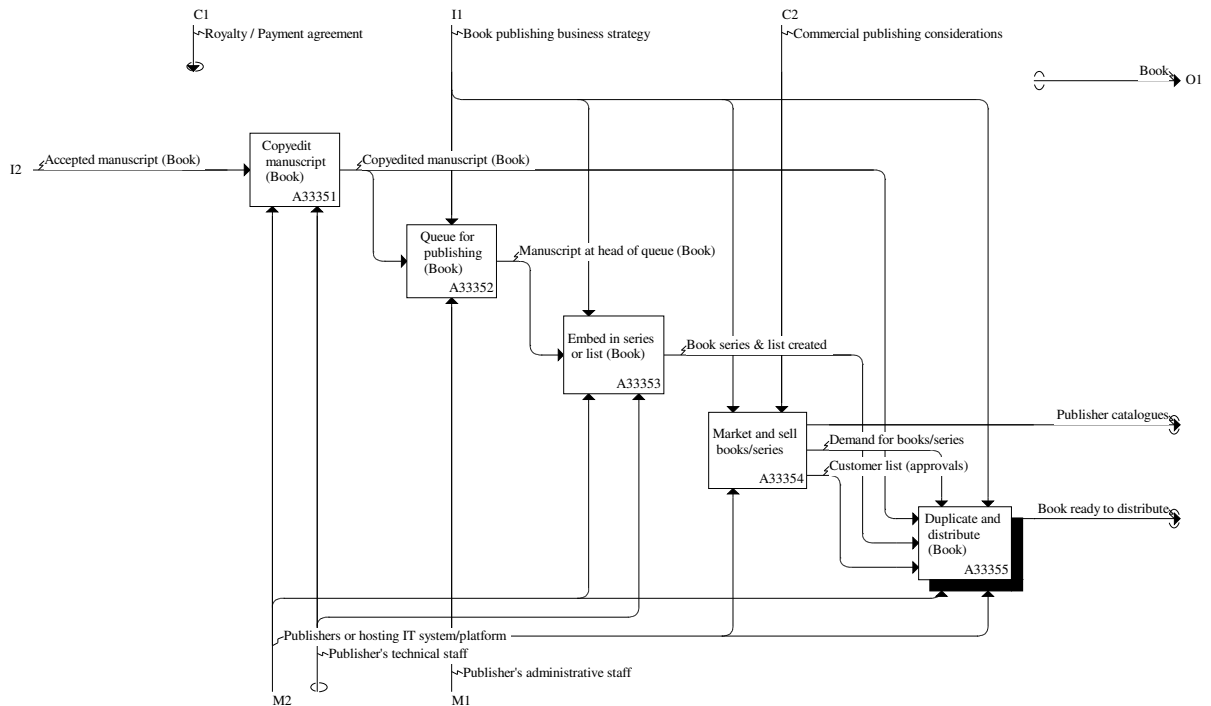
Figure A3332: Editorial / peer review



Link: <http://www.cfses.com/EI-ASPM/SCLCM-V7/>

Source: Scholarly Communication Process Model: Authors' analysis.

Figure A3335: Technical phases of publishing (Book)

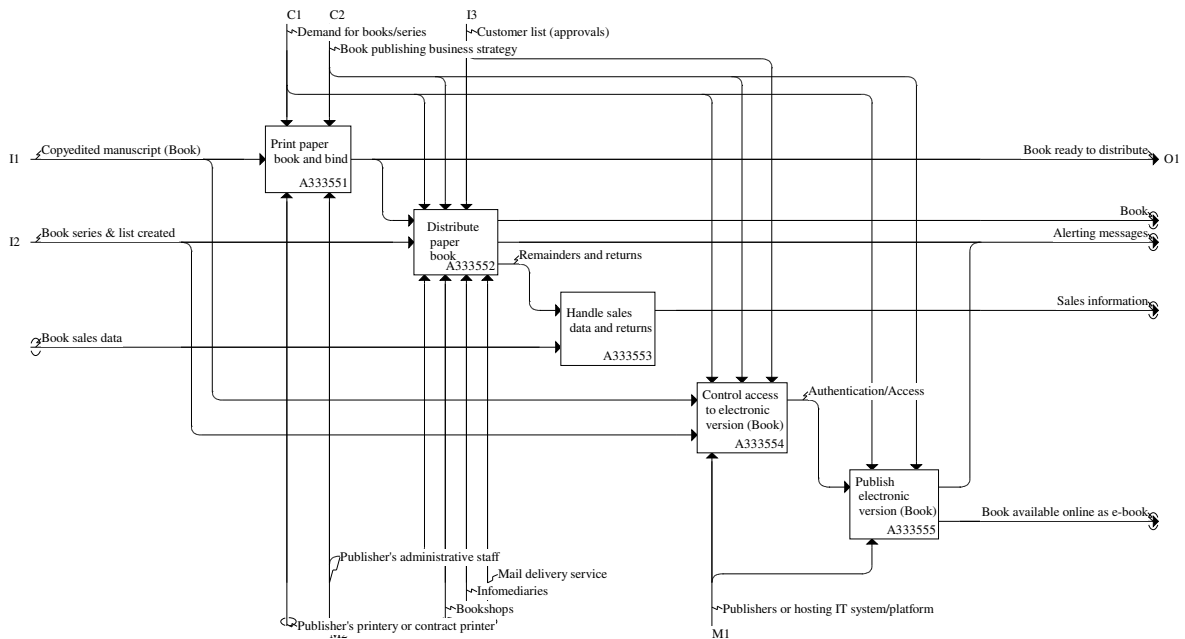


Link: <http://www.cfses.com/EI-ASPM/SCLCM-V7/>

Source: Scholarly Communication Process Model: Authors' analysis.

**A3335:** The technical phases of book publishing are similar to those in journal publishing, involving copyediting and processing, marketing and selling individual titles and series, duplication and distribution (Figure A3335). Marketing and selling individual titles and series also involves the production and distribution of publisher catalogues.

Figure A33355: Duplicate and distribute (Book)



Link: <http://www.cfses.com/EI-ASPM/SCLCM-V7/>

Source: Scholarly Communication Process Model: Authors' analysis.

**A33355: Duplication and distribution** vary between print and electronic publication, although electronic publishing is less common for books and e-only book publishing still quite rare (Figure A33355).

- Print production involves the publisher's administrative staff and internal printery or external contract printer, with activities guided by the publisher's book publishing business strategy and demand for the book, as well as the customer or approvals list. A wider range of distribution mechanisms are used for printed books than is typically the case with journals, with mail or courier delivery to individual purchasers operating in parallel with booksellers, and other distributors and infomediararies.
- Production of an e-book version involves formatting the electronic version, which in the case of books may mean production of an entire copy and/or separate chapters. Access control and hosting systems may be developed and operated by the publisher internally or contracted out to a hosting services supplier, with many publishers using their existing journal platforms or variations thereof.

Book publishing also involves the handling of sales data, remainders and returns from the distribution network (in the case of printed books), and feeding sales information back into the

publisher's book publishing business strategy. The distribution chain is deemed out of scope for the current modelling.

Open Access publishing of books is still relatively rare, although self-archiving of book chapters and entire books is becoming increasingly common, where the publisher's copyright and IP policies allow. There is also an increasing number of OA institutional publishers (e.g. University Presses).

### 2.3.2 Identification of the costs involved in publishing scientific and scholarly works

Much has been written about scholarly publishing costs, with a very extensive literature on the topic. Unfortunately, there have been few comprehensive reviews of costs and publishers themselves have been reluctant to reveal detailed cost data. Few studies distinguish between

Reviews of the literature on publishing and/or publisher costs, and identification of those costs, have been presented in a number of studies, including:

- Halliday, L. and Oppenheim, C. (1999) *Economic Models of the Digital Library*, eLib, United Kingdom Office of Library and Information Networking.
- Tenopir, C. and King, D.W. (2000) *Towards electronic journals: realities for scientists, librarians and publishers*, SLA Publishing, Washington DC. and elsewhere.
- Friedlander, A. and Bessette, R.S. (2003) *The Implications of Information Technology for Scientific Journal Publishing: A Literature Review*, National Science Foundation Special Report, NSF, Washington DC.
- OECD (2005) *Digital Broadband Content: Scientific Publishing*, OECD, Paris.
- European Commission (2006) *Study on the economic and technical evolution of the scientific publication markets in Europe*, European Commission, Brussels.
- Houghton, J.W. Steele, C. and Sheehan, P.J. (2006) *Research Communication Costs in Australia, Emerging Opportunities and Benefits*, Department of Education, Science and Training, Canberra.
- EPS, et al. (2006) *UK scholarly journals: 2006 baseline report – An evidence-based analysis of data concerning scholarly journal publishing*, Research Information Network, Research Councils UK and Department of Trade and Industry.
- King, D.W. (2007) 'The cost of journal publishing: a literature review and commentary,' *Learned Publishing* 20(2), April 2007, pp85-106.
- Björk, B-C. (2007) 'A model of scientific communication as a global distributed information system,' *Information Research* 12(2) paper 307.
- Clarke, R. (2007) 'The cost profiles of alternative approaches to journal publishing,' *First Monday* 12(12), December 2007.
- CEPA (2008) *Activities, costs and funding flows in the scholarly communications system in the UK*, Report commissioned by the Research Information Network (RIN), May 2008.

publishing costs (*i.e.* all costs relating to publishing) and publisher costs (*i.e.* the subset of publishing costs faced/met by publishers). Most reviews of journal publishing either assume or explicitly focus on subscription publishing, with relatively few exploring alternative publishing models. Nevertheless, there is an extensive literature on the costs of scholarly journal publishing and a more limited literature on scholarly book publishing. Even in the case of journals, however, discussion rests on relatively few original sources – with authors building their analysis on a limited number of key studies.

Extensive reviews of the literature have been presented in a number of recent studies (see box above), and it not our intention to present another such review.<sup>24</sup> Rather, we focus on a few key sources that have *identified* and characterised the costs involved in scholarly publishing. The quantification of those costs is the topic of Part II of this report.

### Journals and journal articles

Journal costs vary significantly between publishers, with each title and each publisher facing different costs. Those costs vary with the number of manuscripts submitted, rejection rates, the number of articles published, number of issues published, the size of articles and the number of article and non-article pages, the number of special graphics, the level of peer review and proportion of content peer reviewed, whether the journal is print, e-only or dual-mode, economies of scale and the size of the publisher’s title portfolio, the publishing business model (*e.g.* subscription – individual and Big Deal, advertiser supported, sponsor supported OA publishing or author-pays, and various hybrids and mixes), etc. “Every journal is different and has different cost factors” (King 2007, p93). Moreover, limited market competition in journal publishing has limited cost pressures, leading to the possibility that there are some inefficiently performed activities and higher than necessary costs in the publishing value chain. Consequently, there is no such thing as *the* cost of publishing a journal or article, and publisher costs are not necessarily an accurate guide to real or potential competitive market costs.<sup>25</sup>

Many authors have explored the cost elements and drawn distinctions between fixed and variable costs (and sometimes marginal and incremental costs), direct and indirect costs. Unfortunately, there are grey areas at the margins and usage is not always consistent (*e.g.* for some analysts variable costs relate to the number of subscriptions alone, while for others costs also vary with the number of submissions and rejection rates). Nevertheless, as King (2007, p85) observed there is: “...an extensive literature dealing with the publishing cost and price of scholarly journals... [which] provides a solid grounding for understanding the issues involved.”

Tenopir and King (2000, p252) explored the costs associated with the processes and functions which publishers perform as part of traditional print journal publishing, and developed a model of the various elements. They divided activities into five categories: (i) article processing (*i.e.*

---

<sup>24</sup> Reviews of the underlying economic theory and methods of analysis can be found in: Kingma, B.R. (2001) *The Economics of Information: A guide to economic and cost-benefit analysis for information professionals*, Libraries Unlimited, Westport.; and Nilsen, K. (2007) *Economic theory as it applies to Statistics Canada: A review of the literature*, Statistics Canada, Toronto.

<sup>25</sup> Asking what is the cost of producing a journal is like asking what is the cost of producing a motor car. It depends on the make and model, with a wide range of vehicles targeting specific needs and markets.

all article-related activities required to produce the first copy of the journal), (ii) non-article processing (i.e. activities related to covers, table of contents, letters, book reviews, etc.), (iii) journal reproduction (i.e. printing and binding), (iv) distribution (i.e. subscription maintenance, postage and packing) and (v) publishing support (i.e. marketing, sales, administration, finance, etc.). A detailed model was presented for each, using reported prices adjusted to 1995 USD and average parameters for such things as pages per article, articles per issue, issues per year, etc.

Waltham (2005, p12; 2006a) noted that publisher journal publishing costs could be divided into two component categories: *fixed* costs that are incurred regardless of the number of subscribers, and *variable* costs that are associated with each subscription.

- *Fixed costs* involve both content creation and publishing support activities.
  - Content creation costs are all the costs associated with preparing the editorial content for publication, including the editorial office, costs of salaries and space, and reviewing, editing, SGML/HTML/XML coding and composition of both articles and non-article content, such as letters to the editor, book reviews and advertising, in preparation for print and online distribution.
  - Publishing support activities include marketing, advertising sales, finance and administration (including management costs and the office costs of these activities).
- *Variable costs* include manufacturing and paper, printing and binding, and distribution costs of the physical publication or online product, order fulfilment, subscriber file maintenance and customer service for all subscriber types. Incremental costs (or run-on costs) are those attributable to each additional subscription – such as the printing, distribution and subscriber file maintenance of one subscription.

Waltham outlined the proportions of these cost items for the 12 society publishers surveyed. This analysis tends to assume subscription publishing, implying that there would be no variable costs if there were no subscribers (e.g. for an OA journal); whereas, of course, costs also vary with the number of submissions, rejection rate, the number of articles per issue, article page lengths, non-article content, etc.

King (2007, pp86-87) presented a detailed review of publisher journal publishing costs. Building on the analysis of Page *et al.* (1997) he noted that:

*Journal publishing costs can be categorized as fixed, variable, marginal, and average costs. Most writers use the term 'fixed cost' to refer to the total article processing costs of manuscript processing, editing, review, etc., which are fixed in that they remain the same regardless of the circulation of a journal (i.e. number of subscriptions); some components of these costs may, of course, vary with the number of articles or even with their length. The term 'variable cost' is used to refer to costs that vary with the number of subscriptions, such as the cost of reproduction (or printing), subscription maintenance and mailing of paper journals, or subscription maintenance of electronic journals. The 'marginal cost' or 'incremental cost' in this case is the variable cost of one additional subscription...*

*Another important distinction is between direct and indirect costs. 'Direct costs' are those directly identified with a publishing activity such as editing articles or printing issues. 'Indirect costs' involve activities that are necessary but are not directly involved in specific publishing processes. Examples include administration, marketing, financing, utilities, and so on. The total cost of publishing a journal is the sum of the direct (fixed and variable) costs plus the indirect costs.*

While noting a variety of usage in the literature, King suggested seven components of publishing costs, namely: (1) fixed article processing (first-copy), (2) fixed non-article processing, (3) reproduction, (4) distribution, (5) electronic access, (6) marketing, and (7) fully indirect costs (King 2007, p95).

King (2007, pp95-98) described these components as follows (quoting at length):

1. First-copy activities include: manuscript receipt processing, initial acceptance decision-making, and, for those manuscripts selected as acceptable, identifying reviewers or referees, review processing, manuscript processing; for those manuscripts accepted for publication, there follow substantive editing, formatting, copyediting, processing author approval, page preparation, illustration or special graphic preparation, indexing, coding, proofreading, preparation of master images, and final composition.
2. Non-article processing includes such activities as the preparation of covers and tables of contents, and the writing, editing, copyediting, proofing, formatting, coding, preparation of special graphics, and composition/typesetting of editorials, letters and so forth. The cost elements are the fixed cost of handling the non-article materials in each issue, preparing issue covers, editing and proofing pages, and composition.
3. Print reproduction activities include plate-making, printing, collating, and binding. Paper, of course, is the principal resource used, as well as labour and equipment... All of these reproduction costs are unnecessary for electronic journals.
4. Distribution activities for paper journals include wrapping (inserting and sealing), labelling, sorting by post/zip code and mailing... These activities are not required for electronic journals; however, the activities of keeping updated lists of subscribers, their addresses, billing, receipt of payment, and payment status are common to both paper and electronic journals.
5. Marketing and promotion activities include preparation and arrangement for direct mail and other advertising, catalogues, exhibits, and email and telemarketing. They also include arrangements with abstracting and indexing services. These activities and resources are common to both print and electronic journals, although customer support and sales tend to be more expensive for electronic.
6. Indirect costs include:
  - Rights management and copyright protection activities including copyright registration, administering permissions, licensing, and legal counsel.
  - General programme costs, including launching new journals, archiving historical content, new product R&D.



- Administration, including maintaining personnel records and payroll, accounting, managing, equipment maintenance and administration, space allocation, legal and insurance administration, royalty and author-side payment administration.
- Finance activities and costs, including inventory management, interest payment, capitalization of equipment and other resources, and payment of taxes on profit.
- Other indirect sources of cost include insurance and taxes (federal, state, and local), utilities, janitorial services, and unallocated resources such as space, parking, and travel.

Profit/surplus is not included as an indirect cost, but it goes without saying that commercial publishers seek to make a profit and, as some writers point out, most non-profit societies in fact aim to achieve a surplus.

**Table 2.3: Journal publishing costs identified by EPS et al.**

| <i>Publishing support and general overheads</i>   | <i>Article and issue creation costs</i>   | <i>Production and distribution</i>                               |
|---|---|--|
| <b>Journal publishing system support</b>  | <b>Article creation costs ('first copy costs')</b>                                | <b>Printed journals:</b>   |
| Appointing and managing editor/editorial board and then managing changes (when editors resign, retire, are changed) | Review and manage submitted manuscripts   | <i>Production:</i>   |
| Management of other revenue streams (reprints, off-prints, author fees)   | Manage peer review  | Printing   |
| Rights management (including legal permissions and contract management)   | Support authors   | Paper  |
| Sales and marketing (including licence negotiations, promotion to authors, promotion to libraries)                  | Copy-edit/rewrite article content   | Binding  |
| Develop, maintain and update online systems   | Edit/manage illustrations   | <i>Distribution:</i>   |
| Provision of usage statistics   | Quality assurance of e-content (and any multimedia content) and checking metadata | Fulfilment (mailing costs)                                       |
| Data conversion   | Type-setting/page formatting  | Subscription management  |
| Managing the journal list: divesting and acquiring titles, contract negotiations between societies and publishers   | <b>Per issue costs</b>  | Customer service (including claims and global technical support) |
| Launch new journals   | Create and copy-edit non-article content  | <b>Electronic journals:</b>                                      |
| General overheads   | Edit/manage illustrations   | <i>Production:</i>   |
| General management (e.g. HR, finance, strategy planning)  | Quality assurance of e-content (and any multimedia content) and checking metadata | Upload to server and provide ongoing online hosting/storage      |
|   | Type-setting/page formatting  | <i>Distribution:</i>   |
|   | Issue compilation   | Subscription management  |
|   |   | Customer service (including claims and global technical support) |

Source: EPS, et al. (2006) *UK scholarly journals: 2006 baseline report – An evidence-based analysis of data concerning scholarly journal publishing*, Research Information Network, Research Councils UK and Department of Trade and Industry.



EPS *et al.* (2006) presented an extensive and detailed review of the literature on journal publishing activities and costs. Table 2.3 presents their summary of the journal publishing costs identified.

Clarke (2007) built on a number of previous studies in the development of a cost model in which he outlined the elements of journal publishing costs in some detail. Clarke's cost model included: journal establishment; operations (including submission-related, article-related, issue-related and generic activities and costs); infrastructure maintenance costs; and financial aspects. Table 2.4 presents Clarke's analysis, including the activities and cost elements identified, and his description of the actors involved.

**Table 2.4: Journal publishing costs identified by Clarke**

| <i>Activity/Cost</i>  | <i>Description</i>  |
|---|---|
| <b>Establishment</b>  |   |
| Conception and articulation of the journal's name, scope, philosophy and modus operandi | This is generally undertaken by senior academics, but may require time from paid executives.  |
| Preliminary negotiations within the intellectual community                              | This is generally undertaken by senior academics.   |
| Preliminary negotiations with potential providers of operational resources              | This is generally undertaken by senior academics.   |
| Preliminary negotiations with potential providers of infrastructure                     | This is generally undertaken by senior academics, but may require time from paid executives.  |
| Acquisition of investment and working capital   | This may be undertaken by senior academics, but may require time from paid executives.  |
| Appointment of Board, Editor and Editorial Committee(s)                                 | This is generally undertaken by senior academics, although appointment of the Editor may require time from paid executives.   |
| Accumulation of Referees List   | This is generally undertaken by senior academics.   |
| Acquisition of infrastructure   | This may be undertaken by senior academics, but may require time from paid executives. Web sites may be run using gratis, open source tools (ranging from simple to highly sophisticated) or commercial tools involving expensive licence fees. |
| Acquisition of operational resources  | This is generally undertaken by senior academics, but may require time from paid executives.  |
| Acquisition of intellectual property (logos, trademarks, copyrights, licences)          | This may be undertaken by senior academics, or require time from paid executives. The intensity of effort invested varies from virtually nothing to substantial.  |
| Preparation of formal components of the printed journal and Web site                    | This is likely to be undertaken by senior academics, but may require time from paid staff.  |
| Preparation of Web site   | This may be undertaken by junior academics or students, or require time from paid staff.  |
| Announcement to the community   | This is generally undertaken by senior academics, but may require time from paid executives, and perhaps paid advertisements.   |
| Issue of initial calls for papers   | This is generally undertaken by the Editorial Committee.  |

Cont'd.

| <i>Activity/Cost</i>                    | <i>Description</i>  |
|---|---|
| <b>Operations</b>                       |   |
| <b><i>Submission related</i></b>        |   |
| Receipt, acknowledgement and management | This is generally undertaken by the Editor, Editorial Committee and Referees, possibly supported by junior academics or students, or perhaps using the time of paid staff.  |
| Conduct of the assessment process       | This is generally undertaken by the Editor, Editorial Committee and Referees, generally gratis, but possibly with an honorarium for the Editor, and possibly allowances, free advertising or similar partial recompense.  |
| <b><i>Article related</i></b>           |   |
| Production editing                      | This is undertaken possibly by the Editor or a member of the Editorial Committee, but more likely by a junior academic or student, or using the time of paid staff. Some of the effort may be outsourced to the author.   |
| Cataloguing                             | The preparation, review and formatting of metadata, and entry into appropriate catalogue(s), is generally undertaken by a junior academic or student, or using the time of paid staff. Some of the effort may be outsourced to the author.  |
| <b><i>Issue related</i></b>             |   |
| Editorial                               | This is undertaken by the Editor.   |
| Production-editing                      | This is undertaken possibly the Editor or a member of the Editorial Committee, but more likely a junior academic or student, or using the time of paid staff.   |
| Production                              | For hard-copy issues, printing is likely to be either performed by paid staff, or outsourced. For soft-copy issues, uploading and release of the transmittable format (commonly HTML or PDF), may be undertaken by the Editor or a member of the Editorial Committee, but more likely by a junior academic or student, or using the time of paid staff.                   |
| Protection                              | For soft-copy issues, protections such as password- and/or cryptography-based locking mechanisms or watermarks may be imposed. Activities like this are likely to be either performed by paid staff, or outsourced, or possibly performed by special-purpose software.  |
| Distribution                            | For hard-copy issues, distribution is likely to be either performed by paid staff, or outsourced. For soft-copy issues, generation of the issue home page and issue of an announcement to the subscription list may be undertaken by the Editor or a member of the Editorial Committee, but more likely by a junior academic or student, or using the time of paid staff. |
| <b>Generic</b>                          |   |
| Marketing                               | This is a highly variable activity, from effectively nil to substantial.<br>It may be undertaken by senior academics assisted by junior academics or students, or require time from paid executives and paid staff.   |

Cont'd.

## Economic implications of alternative scholarly publishing models

| <i>Activity/Cost</i>                    | <i>Description</i>  |
|---|---|
| Customer relationship management        | This is a highly variable activity, from minimalist records to a substantial database, and minimalist to substantial customisation of services. It includes the costs of collecting revenue. This may be undertaken by a junior academic or student, or may require time from paid staff.   |
| Archive management                      | This is a highly variable activity, ranging from leaving the articles in an accessible location, to releasing them from subscriber-only to open access after a period of time, to strongly protected access, including payment facilities for per-view and short-period access. The more sophisticated facilities may (but may not) require software licences, and time from paid staff.  |
| Indexing                                | This is a variable activity, ranging from leaving the site open to Web crawlers and perhaps pointing to one of them, to using a gratis local search engine, or a for-fee local search engine, or a sophisticated facility including auto-generated cross-linkages among articles within the journal or a journal collection, or across multiple collections. The more sophisticated facilities may (but may not) require software licences, and time from paid staff. |
| Governance                              | This involves meetings of the Editorial Committee(s) and periodic reports to stakeholders. These may be undertaken by senior academics, may possibly require time from paid executives, and may involve travel costs.   |
| <b>Infrastructure maintenance</b>       |   |
| Editor and Editorial Committee(s)       | This is occasional, ongoing activity by the Editorial Committee(s), undertaken by senior academics.   |
| A pool of referees                      | This is ongoing activity by the Editor and Editorial Committee(s).  |
| Communications channels                 | This is generally arranged by senior academics, supported by junior academics or students.  |
| Norms for communications and formatting | This is ongoing activity by the Editor and Editorial Committee(s).  |
| Production facilities                   | For hard-copy issues, this is likely to require support by paid staff, or outsourced service providers. For soft-copy issues, it is more likely to be guided by senior academics, and undertaken by junior academics or students, or using the time of paid staff.  |
| Subscription-list facilities            | As for production facilities above.   |
| Distribution mechanisms                 | As for production facilities above.   |
| <b>Financial</b>                        |   |
| Interest on investment capital          | The assets required to run the operation may be insignificant, or may be gifts, provided by grants, or sponsored. Otherwise, the financial value tied up in the assets needs to be remunerated as interest payments or dividends.   |
| Interest on working capital             | As for investment capital above.  |

Source: Clarke, R. (2007) 'The cost profiles of alternative approaches to journal publishing,' *First Monday* 12(12), 3 December 2007.

Many authors have pointed to the cost savings possible by moving to e-only and cutting out print (or making it a priced add-on), and by automating the journal production process and cutting out unnecessary activities and costs. There are journal submission and peer review management systems readily available that make operating a journal relatively inexpensive, and some are available free open source (*e.g.* DPubS, E-Journal, ePublishing Toolkit, GAPWorks, HyperJournal, OpenACS, SOPS, Topaz and Open Journal Systems (Suber 2007b)). Such systems greatly reduced the need for formatting and the ‘typesetting’ activities of the print era, as well as content handling and management costs. Self-evidently, journal production costs will vary between print and electronic formats as well as e-only and dual-mode (*e.g.* physical formatting and printing costs versus electronic formatting and uploading as HTML, PDF, etc.).

Reporting on the publishing activities of North American research libraries, Hahn (2008, pp17-18) noted that:

*Libraries’ products certainly resemble many publications produced by traditional publishers, but they are largely electronic-only and basic in their design. Limiting services to purely electronic publications offers some significant advantages over print-oriented publishing. Costs are kept low by simplifying production and design and relying on open-source software. Online full-text publishing meanwhile enables discovery by a wide range of search engines and full-text searching, reducing the need for marketing. Workflows tend to be streamlined and almost all services are highly automated once production commences. Design work is usually done on a very modest scale. As with most scholarly publishing, much of the work of content recruitment and selection, and even some editing, is done by unpaid volunteers drawn from the ranks of active scholars and researchers. The largest costs lie in the startup process of advising, prototyping, creating workflows, and generating whatever layout and graphic design is considered adequate. Ongoing support costs for these activities accrue on a modest scale. Typically editors, authors, or association partners receive little in the way of expensive services such as elaborate design and layouts or extensive copyediting.*

Conversely, electronic publishing can raise costs as user expectations drive the inclusion of online features and linking not possible in print. Publisher marketing, technical systems and customer support costs can also be higher as more skilled staff are required. There is also fear among publishers that e-only publishing may lead to a loss of advertising revenue and, for society publishers, membership revenue (Johnson and Luther 2008).

Relatively few authors have addressed the issue of cost differences between alternative publishing models. Hedlund, *et al.* (2004) presented results of a small survey of OA journal publishers that included a breakdown of time spent on various activities. SQW (2004) were among the first to explicitly compare costs across alternative business models, concluding that: “Total system costs are lower in an author-pays system because licensing, and other activities aimed at reducing access to articles, are unnecessary.” (SQW 2004, p4), and “Total costs for author-pays journals are likely to be lower. They include some extra cost for managing the charging system for authors but do not carry any costs for subscription management, licence negotiations, or many sales costs.” (SQW 2004, p14).

EPS *et al.* (2006) reviewed the literature to mid 2006 and addressed the issue of costs and impacts of formal dissemination models. They concluded that too little was known about costs to be definitive about publisher cost differences, but that it was clear that there were differences in the attributions of costs – with research intensive organisations facing higher costs under an author-pays than subscription system (a point made by many authors (*e.g.* Davis *et al.* 2004)).

Table 2.5 presents a summary of the major cost items for journal publishing, based on the process model outlined above and a review of the literature. They include:

- Establishment costs relating to the establishment of new journal titles;
- Operational costs relating to on-going operations, including article and non-article content processing, production and distribution; and
- Overheads, including a range of development, marketing, sales, administration, equipment and facilities costs.

Table 2.5: Publish scientific and scholarly works: major cost items (Journals)

| <i>Activity/Item</i>  | <i>Type<br/>(per title)</i> | <i>Description</i>  |
|---|-----------------------------|---|
| <b>Establishment:</b>   | <b>Direct</b>               | <b>Costs relating to establishing a new journal title</b>   |
| Title development and launch  | Fixed                       | Costs of investigating demand from authors and readers  |
| Establish 'editorial office', recruit editor and editorial board          | Fixed                       | Costs of establishing the title's management and oversight  |
| Operate and manage editorial board meetings                               | Fixed                       | Overall management of journal business strategy   |
| Include new title in existing system for author recruitment and marketing | Fixed                       | Embedding title into publisher's operations   |
| <b>Operation:</b>   | <b>Direct</b>               | <b>On-going operational costs</b>   |
| <b><i>Article processing (first-copy costs)</i></b>                       |                             | <b><i>Costs associated with production of an article</i></b>  |
| Handling submissions (internal)   | Variable                    | Management of submissions (incl. author 'copyright' agreement, payment agreement for author-pays, etc.)       |
| Peer review management (internal)   | Variable                    | Management of the peer review process   |
| Article/manuscript production (internal)                                  | Fixed                       | Editing, formatting, proofing, 'typesetting', etc. including illustrations, data conversion, hyperlinks, etc. |
| Peer review conduct (external)  | Variable                    | Work of external peer reviewers   |
| Revision and re-submission (external)                                     | Variable                    | Work of author(s) in revision and re-submission   |
| <b><i>Non-article processing</i></b>                                      |                             | <b><i>Costs associated with non-article journal content</i></b>   |
| Covers  | Fixed                       | Preparation and proofing  |
| Index   | Fixed                       | Preparation and proofing  |
| Editorial   | Fixed                       | Handling, preparation and proofing  |
| Letters   | Variable                    | Handling, preparation and proofing  |
| Book reviews  | Variable                    | Handling, preparation and proofing  |
| News and commentary   | Variable                    | Handling, preparation and proofing  |
| Advertising content   | Variable                    | Handling, preparation and proofing  |
| <b><i>Production and distribution</i></b>                                 |                             | <b><i>Costs of (re)production and distribution</i></b>  |
| Quality assurance   | Fixed                       | Costs of quality assurance (incl. e-content, multimedia, metadata, etc.)                                      |
| Issue compilation   | Fixed                       | Costs of compiling the issue, embedding content, etc.   |
| <i>Print</i> : Printing and binding, etc.                                 | Variable                    | Costs of paper, printing and binding  |
| <i>Print</i> : Packaging and postage                                      | Variable                    | Costs of packaging and postage  |
| <i>Online</i> : Operation of systems and servers                          | Fixed                       | Operation of servers and systems (incl. hosting, upload, upgrades, etc.)                                      |
| <i>Online</i> : Attaching DOIs  | Fixed                       | Costs of generating and attaching DOIs  |
| <i>Online</i> : Authentication and access control                         | Fixed                       | Costs of access control (toll access only)  |
| <i>Online</i> : Technical and customer support                            | Variable                    | Customer support costs (technical, claims, etc.)  |
| <i>Online</i> : Usage statistics  | Fixed                       | Costs of generation of usage statistics   |
| <i>Distribution</i> : Indexing and abstracting                            | Fixed                       | Costs of indexing and abstracting   |
| <i>Distribution</i> : Subscription maintenance                            | Variable                    | Subscription maintenance (subscription model only)  |

| <i>Activity/Item</i>                   | <i>Type<br/>(per title)</i> | <i>Description</i>   |
|--|-----------------------------|--|
| <b>Overheads:</b>                      | <b>Indirect</b>             | <b>Business and operational overheads</b>  |
| Development of systems                 | Fixed                       | Costs of IT/manual systems/platforms development   |
| <i>Marketing</i> : to authors          | Fixed                       | Costs of author recruitment  |
| <i>Marketing</i> : to buyers / readers | Variable                    | Costs of marketing title   |
| <i>Sales</i> : Price negotiations      | Variable                    | Cost of sales negotiation (price in subscription model)  |
| <i>Sales</i> : Licensing negotiations  | Variable                    | Cost of sales negotiation (price in subscription model)  |
| <i>Rights</i> : Copyright permissions  | Variable                    | Costs of handling copyright permissions  |
| Payments                               | Variable                    | Costs of handling payments (incl. subscriptions, author-pays, sponsors, advertising, payment to editors and reviewers, etc.) |
| General administration                 | Fixed                       | Administration overheads   |
| Building, facilities and equipment     | Fixed                       | Costs of facilities  |
| Finance and business reporting         | Fixed                       | Costs of accounting and reporting  |

Note: Whether costs (per title) are fixed or variable is less than clear cut, as many of the 'fixed' costs of publishing are determined by the business model and journal business strategy adopted (*i.e.* can vary with the model or strategy). Moreover, some costs may be variable costs per title and fixed per article (*e.g.* printing which may vary with the number of articles per title, pages per article or the nature of article content).

Source: Authors' analysis.

## Research monographs and books

Far fewer authors have examined scholarly monograph/book publishing costs in detail. Watkinson (2001, pp24-25) examined some of the costs associated with publishing research monographs, and suggested average print runs of around 750 (range 400 to 1,500) and falling, average selling prices of around USD 40, and average sales of around 400 circa 2000. Dryburgh (2002, p17) surveyed 10 publishers and found median commissioning costs of £1,800 and development editing of £1,600. Clark (2001) and Greco and Wharton (2008) presented detailed breakdowns of scholarly book publishing costs, while a number of other authors have presented detailed examinations of book publishing (Greco 2003; Kasdorf 2003; Thompson 2005; etc.).

Electronic publishing of monographs and texts offers opportunities for innovation, cost savings and value adding. It has been suggested that cost savings may actually be greater than for journals due to the extent of formatting and editorial work and the high cost of physical distribution to stock and the management of inventory (Halliday and Oppenheim 1999). Electronic publishing of research monographs also promises to enable the publication of scholarly works for which there may not be a sufficiently large commercial market for them to find a print publisher, thus alleviating one of the current crises in publishing in the arts and humanities (Bazerman *et al.* 2008). New OA models for book publishing are emerging rapidly, combining e-presses and OA repositories, and where required print-on-demand facilities (Steele 2008).

Table 2.6 presents a summary of the major cost items for scholarly book publishing, based on the process model outlined above and a review of the literature.

Table 2.6: Publish scientific and scholarly works: major cost items (Books)

| <i>Activity/Item</i>                               | <i>Type<br/>(per title)</i> | <i>Description</i>  |
|--|-----------------------------|---|
| <b>Establishment:</b>                              | <b>Direct</b>               | <b>Costs relating to establishing a new title</b>   |
| Investigate demand from authors and readers        | Fixed                       | Costs of title development, author recruitment, etc.  |
| Include new title in existing system for marketing | Fixed                       | Embedding title into publisher's catalogue, etc.  |
| <b>Operation:</b>                                  | <b>Direct</b>               | <b>On-going operational costs</b>   |
| <b><i>Manuscript processing</i></b>                |                             | <b><i>(first-copy costs)</i></b>  |
| Handling manuscript submissions (internal)         | Variable                    | Management of submissions (incl. author 'copyright' agreement, payment agreement for royalties or 'author-pays', etc.). |
| Review management (internal)                       | Variable                    | Management of the editorial and peer review process.  |
| Manuscript production (internal)                   | Fixed                       | Editing, formatting, proofing, 'typesetting', etc. including illustrations, data conversion, hyperlinks, etc.           |
| Peer review conduct (external)                     | Variable                    | Work of external peer reviewer(s).  |
| Revision and re-submission (external)              | Variable                    | Work of author(s) in revision and re-submission.  |
| <b><i>Non-manuscript processing</i></b>            |                             | <b><i>Costs associated with non-manuscript content</i></b>  |
| Covers   | Fixed                       | Preparation and proofing.   |
| Index (external/automated)                         | Fixed                       | Preparation and proofing.   |
| Advertising content                                | Variable                    | Handling, preparation and proofing.   |
| <b><i>Production and distribution</i></b>          |                             | <b><i>Costs of (re)production and distribution</i></b>  |
| Quality assurance                                  | Fixed                       | Costs of quality assurance (incl. e-content, multimedia, metadata, etc.).   |
| <i>Print:</i> Printing and binding                 | Variable                    | Costs of paper, printing and binding.   |
| <i>Print:</i> Packaging and postage                | Variable                    | Costs of packaging and postage/shipping.  |
| <i>Online:</i> Operation of systems and servers    | Fixed                       | Operation of servers and systems (incl. upgrades)/hosting costs.  |
| <i>Online:</i> Authentication and access control   | Fixed                       | Costs of access control (toll access only).   |
| <i>Online:</i> Technical and customer support      | Variable                    | Support costs.  |
| <i>Online:</i> Usage statistics                    | Fixed                       | Costs of generation of usage statistics.  |
| <i>Distribution:</i> Indexing and abstracting      | Fixed                       | Costs of indexing and abstracting.  |
| <i>Distribution:</i> Sales data and returns        | Fixed                       | Costs of collecting sales data and handling returns.  |
| <b>Overheads:</b>                                  | <b>Indirect</b>             | <b>Operational overheads</b>  |
| Development of systems                             | Fixed                       | Costs of IT/manual systems/platforms development.   |
| <i>Marketing:</i> to authors                       | Fixed                       | Costs of author recruitment.  |
| <i>Marketing:</i> to buyers / readers              | Variable                    | Costs of marketing title.   |
| <i>Sales:</i> Price/fulfilment negotiations        | Variable                    | Cost of sales negotiations (price in toll access model).  |
| <i>Rights:</i> Copyright permissions               | Variable                    | Costs of handling copyright permissions.  |
| Payments   | Variable                    | Costs of handling payments (incl. purchases, royalties, advertising, payment to reviewers, etc.).                       |
| General administration                             | Fixed                       | Administration overheads.   |
| Building, facilities and equipment                 | Fixed                       | Costs of facilities.  |
| Finance and business reporting                     | Fixed                       | Costs of accounting and reporting.  |

Note: Whether costs are fixed or variable (per title) is less than clear cut, as many of the 'fixed' costs of publishing are determined by the business model or strategy adopted. Source: Authors' analysis.



### 2.3.3 Funding flows relating to scientific and scholarly publishing

Funding flows around publishing are more complex than in other areas, with sources and flows depending in part on the publishing business model.

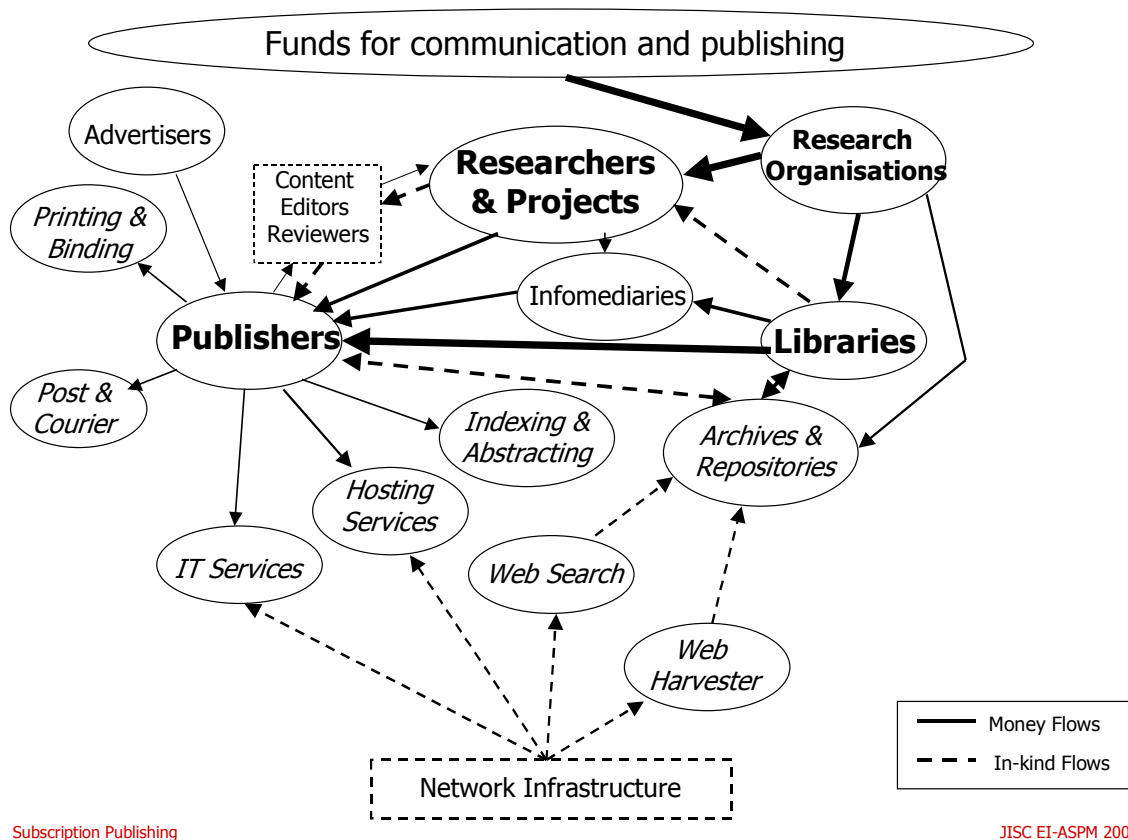
**Journal publishers** often rely on revenue from a number and variety of sources (See, for example, Kaufman-Wills 2005, p43), including:

- *Subscription revenues* from individual or institutional subscribers, by title and by ‘Big Deal’ package;
- *Individual article, reprint and pay-per-view revenues* from individual or institutional users;
- *Content licensing* from third-parties for access to content;
- *Advertising revenues* from organisations seeking to sell to the journal’s readers, which can be quite substantial in areas where there are large professional readerships (*e.g.* medicine);
- *Author-fees* in the form of page charges or fees for submission and/or publication charged to authors directly or to their institutions and/or funders;
- *Membership fees* from society membership (*e.g.* membership fees that include a ‘free’ journal); and
- *Sponsorship and support* in the form of financial support for the operation of the journal.

There are also funds flowing within the publishing process: between publishers, contract services suppliers, distributors and infomediaries; and sometimes between publishers and editors and reviewers. More typically, however, external editorial and peer review activities are unpaid or paid at less than full cost, with an implied (in-kind) funding flow running from the research institutions that support the editorial and peer review activities of their research staff. In another implied (in-kind) flow, the content itself (*i.e.* manuscripts) is typically free, with the research and preparation activities supported from research funding (be it grant funding or institutional block grants).

Those operating a **toll access**, mixed or hybrid toll access business model primarily rely on subscription and per article or pay-per-view charges to generate revenues, but advertising revenues can also be substantial (Figure 2.3). Toll access publishers may also impose page charges on their authors.

Figure 2.3: Simplified funding flows relating to subscription publishing

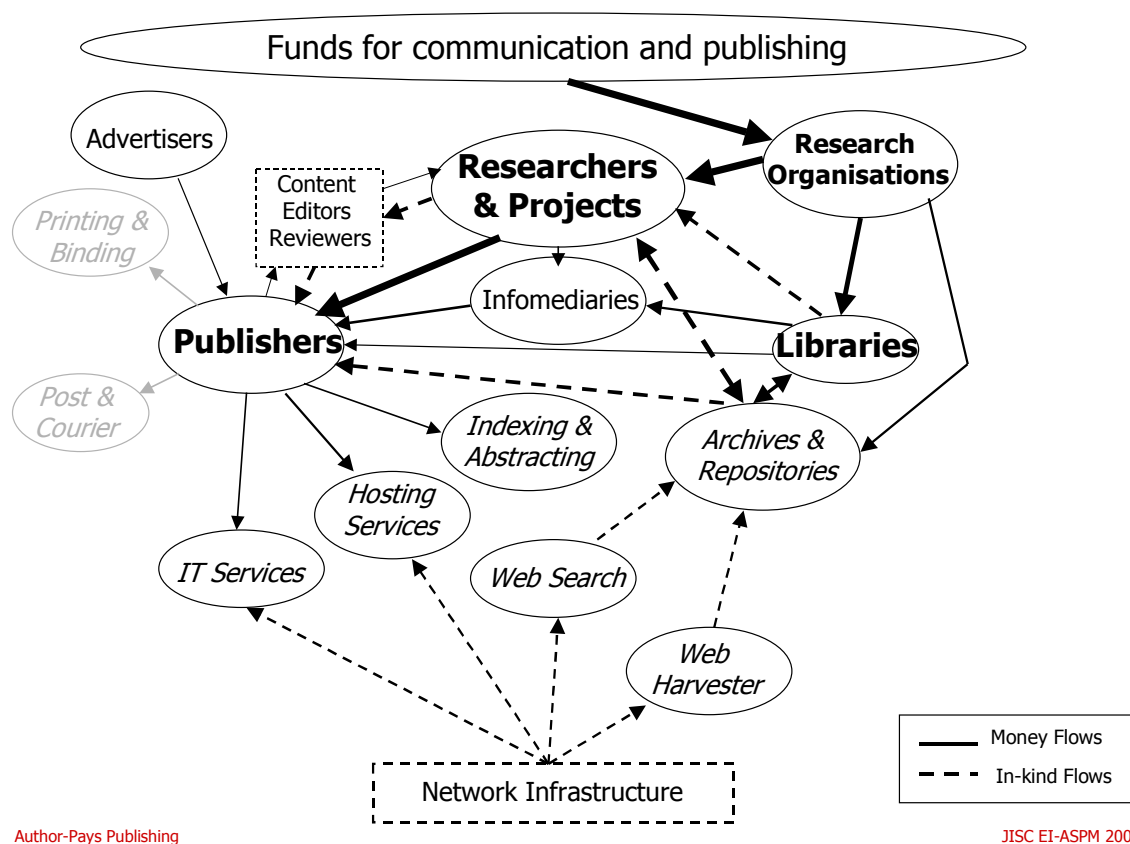


Source: Authors' analysis.

**OA journal publishers** do not impose reader-side access charges, and tend to rely on author-side charges and/or sponsorship and other support (Figure 2.4). Advertising revenues may also be substantial. As discussed above, author-side charges can take a number of forms, with some of the larger OA publishers operating 'membership models', wherein author fees are reduced or waived for authors from member institutions that pay membership fees (subscriptions) and/or authors who are members of a particular society. Some also reduce or waive author-fees for active reviewers.

Kaufman-Wills (2005) reported a survey of journal publishers noting, *inter alia*, that: fewer than 50% of OA journals charged author fees, while a number of subscription journals charged page and other article processing fees; and journals published under all business models relied to some extent on volunteers, in-kind support and sponsorship.

Figure 2.4: Simplified funding flows relating to author-pays publishing



Author-Pays Publishing

JISC EI-ASPM 2008

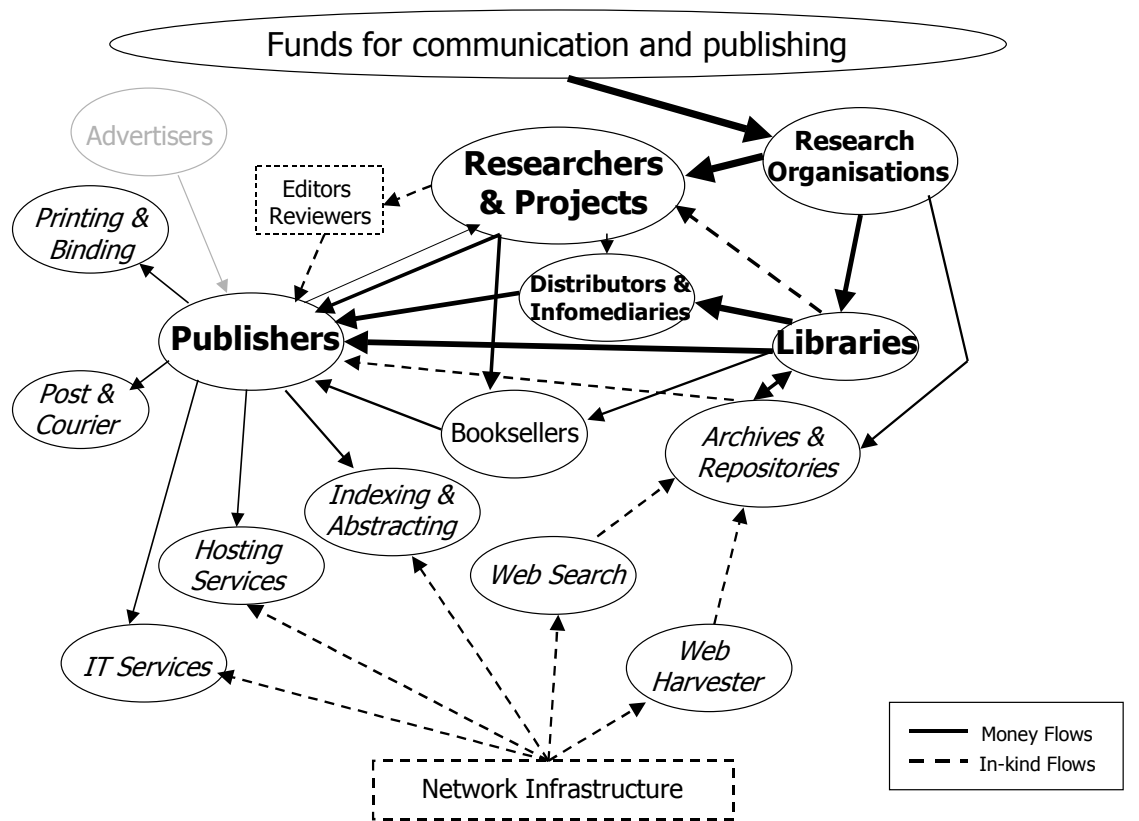
Source: Authors' analysis.

**Book publishers** tend to rely more on sales revenue from the reader-side, be it from individual or institutional purchasers. They may also impose page charges or publication charges on authors, receive revenue from advertisers, and support from sponsors. Unlike journal publishing, book publishers often pay royalties to their authors.

The type of publisher can also affect the flow of funds, with commercial publishers using investors' funds to develop and grow their business and generate returns to their investors, while society publishers may use their membership fees to generate such funding for their publishing activities, and institutional publishers may draw institutional support for theirs (Figure 2.5).

As with journals, there are also funds flowing within the publishing process: between publishers, contract services suppliers, distributors and infomediaries, and sometimes between publishers and external reviewers. More typically, however, external editorial and peer review activities are paid at less than full cost, with an implied (in-kind) funding flow running from the research institutions that support the editorial and peer review activities of their staff. In another implied (in-kind) flow, the content itself (*i.e.* manuscripts) is typically free or traded for a small share in net revenues generated in the form of royalties, with the bulk of the research and preparation activities supported from research funding (be it grant funding or institutional block grants).

Figure 2.5: Simplified funding flows relating to publishing scholarly monographs



Book Publishing

JISC EI-ASPM 2008

Source: Authors' analysis.

As a result, the sources of funds flowing into publishing are many and varied – with multiple sources common and many different sources in evidence. However, perhaps the most important differences are between toll access and open access publishing models, and reader-side versus producer-side sources, respectively.

### 2.3.4 The impacts of alternative publishing models on scholarly publishing activities

Alternative publishing models are in large part alternative publisher revenue models, so the impacts of alternative models on publishing revenues and on the flow of funds are profound. While no doubt significant, impacts on publishing costs may not be as profound as they at first appear – with many of the core activities remaining under different models. Perhaps, greater differences lie in the switch from print and dual-mode publishing to an e-only model – although disentangling the essential cost differences of alternative publishing models from 'print economics' and the economics of digital delivery (Cockerill 2006 and OECD 2005) is by no

means easy as OA publishing and self-archiving entail online delivery while toll access can be based on online, print or dual-mode delivery.<sup>26</sup>

## Costs and impacts

Key areas of journal publishing cost difference between toll and open access include:

- Peer review efficiency and quality:
  - *Reviewer* – ease of access to cited and related materials that are available through OA publishing or self-archiving might facilitate more efficient and potentially higher quality peer reviewing.
  - *Publisher* – more efficient, higher quality and more timely peer review (as above) would enable higher quality journal publishing, reduce cost and improve timeliness. It would also allow publishers to draw on a wider network of reviewers (*e.g.* practicing professionals that without OA would have limited ability to check cited and related material for interpretation).
  - *Reader/user* – improved peer review would better filter content, and may reduce the time-cost involved in accessing and studying poorer quality content.
- Access controls and authentication systems:
  - *Publisher* – costs faced in the subscription/toll publishing model are avoided with OA publishing, thus reducing the complexity and cost of platform and systems development, and IT and technical user support (with access difficulties being a very common user support issue).
  - *User* – ease and speed (therefore time-cost) of access are also improved from the user side – although these are not a part of the publishing costs *per se* (Nilsen 2007).<sup>27</sup>
- Handling permissions (to use and re-use) (Halliday and Oppenheim 1999, p35):<sup>28</sup>
  - *Publisher* – permissions handling may be simplified in any model, but most especially OA publishing, through the use of standard and/or more open licensing and blanket permissions.

---

<sup>26</sup> There is no reason that OA publishing (especially under the author-pays model) should not be print and/or dual-mode, but most studies assume that OA publishing and self-archiving are predicated on online (e-only) delivery.

<sup>27</sup> Nilsen (2007) noted that: “Opportunity costs apply equally to consumers, and the imposition of these costs (*e.g.* in dollars and time) on information users can reduce the social net benefit of an information product or services.”

<sup>28</sup> Halliday and Oppenheim (1999, p35) noted that: “This cost includes not only the price for using copyright material but also time spent identifying rightsholders, seeking permission to use their copyright material and, often, chasing that request. The total figure can be as high as ten times the actual copyright fee... The cost to rightsholders of administering permissions requests is also significant. At present the Association for Computing Machinery (ACM) grants blanket permission to copy its copyright materials for educational use because the cost of administering applications exceeds the revenue generated...”

- *User* – costs of obtaining permissions would also be reduced, and OA permissions allowing greater freedom of use and re-use increase the value of the material to the users and enable forms of research not possible/practicable under copyright restrictions (*e.g.* text mining).
- Negotiating licenses:
  - *Publisher* – costs relating to licensing negotiations under the ‘Big Deal’ subscription model are avoided in OA publishing.
  - *User (research library)* – costs relating to Big Deal licensing negotiations are similarly avoided.
- Negotiating prices:
  - *Publisher* – costs relating to Big Deal package price negotiations are avoided in OA publishing, although some OA publishers may operate institutional membership schemes that require negotiation.
  - *User (research library)* – costs relating to Big Deal price negotiations are similarly avoided, although again some OA publishers may operate institutional membership schemes.
- Payments handling:
  - *Publisher* – payments handling costs could be reduced with reduced volume and variety of payments (*e.g.* subscriptions, pay-per-view, advertising, sponsor, author-pays, etc.), suggesting an increased cost for hybrid and mixed publishing models, and, perhaps, for author-pays models, although membership models may counteract this.<sup>29</sup>
  - *User (research library, reader and/or author)* – payments handling costs could also be reduced with reduced volume and variety of payments, again suggesting an increased cost for author-pays payments models, although membership models may counteract this.
- Costs of negotiation of ‘copyright’ agreements with authors can be reduced (for both publishers and authors when) copyright is not transferred and agreements are simplified and standardised.
- Distribution:
  - *Publisher* – distribution costs could be reduced in OA publishing through the use of OA repositories (*e.g.* PubMed Central) or hosting services (*e.g.* HighWire) instead of using proprietary in-house systems for distribution.

---

<sup>29</sup> Conversely, membership models for author-pays break the link of the price signal between buyers and sellers, effectively replicating one of the barriers to effective market competition afflicting the toll access publishing model when operating through research library subscriptions.

- *User (reader)* – access costs could be reduced similarly through the avoidance of having to use multiple proprietary interfaces with relatively poor cross-platform integration.
- Changing publishers and/or packages:
  - *Publisher* – costs relating to renegotiations of access, conditions and price caused by a journal title changing publishers and/or changing delivery to a different proprietary package would be avoided in OA publishing.
  - *User (research library)* – costs relating to renegotiations of access, conditions and price caused by a journal title changing publishers and/or changing delivery to a different proprietary package would also be avoided in OA publishing.<sup>30</sup>
- Financing operations:
  - OA publishing models using author-pays or sponsorship revenue models are likely to provide greater certainty about future revenues than is the case with sales-dependent subscription publishing (*e.g.* known level of sponsorship, set number of articles per issue, etc.). This reduced level of risk should, over time, be reflected in a reduced user cost of capital for OA publishers.
  - OA publishing may have a positive impact on revenue, through increasing advertising revenue as a result of increased visibility (Kaufman-Wills 2005, p13).
- Impact of OA on scholarly societies – it has been suggested that scholarly society subscription/membership publishers would feel a negative impact in moving to OA publishing as they have often used some of their publishing revenues to support other activities. In so far as this represents compensation for development ‘capital’ it is entirely legitimate, but a cross-subsidy that goes beyond that is effectively a ‘hidden tax on knowledge’. Making such cross-subsidies more transparent could be thought to be a positive from a system-wide perspective and, of course, stopping them would reduce overall publishing costs.<sup>31</sup>
- Publishers’ comments – Kaufman-Wills (2005, pp22-23) reported a number of publishers’ comments from their 2005 survey, including:
  - “Our [Full] Open Access initiative (displaying accepted, non-copy-edited articles immediately) has substantially increased manuscript submissions.” – which may raise the quality of the journal;

---

<sup>30</sup> This issue has been the topic of recent voluntary guidelines for publishers involved in any journal transfer, which cover the issues of ongoing access provision to online content, exchange of subscriber lists, DOI and URL transfer as well as perpetual access rights to journal content (see <http://www.uksg.org/transfer/papers>).

<sup>31</sup> Society concerns about potential loss of membership and advertising revenue through shifting to e-only publishing should be considered, but not confused with the implication of OA publishing.

- “Open Access may increase competition [among journals] for manuscripts.” – which may put downward pressure on publishers’ costs and increase pressure to offer value-adding services that authors value. Indeed, a number of other comments reported suggested that process efficiencies were being implemented as a result of the pressures of OA publishing; and
- “[Open Access has led to] increases in consumer readership.” – implying that there was reduced access and use by non-research readers under non-OA publishing models, and an increased professional readership may be attractive to advertisers, thereby increasing publisher revenue.

Self-archiving (*i.e.* Green OA) also has potential impacts, including:

- Impact of OA repositories on subscriptions – a number of studies have noted the potential for availability of articles on OA archives and repositories to have a negative impact on subscriptions (*e.g.* Ware 2006; Beckett and Inger 2007), but to date no definitive evidence has been produced. It is worth noting that arXiv has had no obvious impact on subscriptions to physics journals despite extensive coverage and years of operation (Pinfield 2007),<sup>32</sup> and the relationship between arXiv and journals in the areas concerned may be positive, rather than negative (Swan 2005). The same has been said of Nature Precedings (Hannay and Spencer 2008).
- Hosting and overlay services – OA repositories could provide opportunities for publishers to reduce their costs (*e.g.* providing free hosting services and eliminating or reducing distribution costs), and develop new revenue streams (*e.g.* from overlay and value adding services) (Newbery and Bently 2008).<sup>33</sup>
- Repositories may raise the visibility of the hosting/supporting institution and, thereby, reduce marketing costs for a given level of research funding and student enrolment and/or increase funding and enrolments.

Alternative publishing models are less common in research monograph (book) publishing, but there may be some significant impacts.

- Journal subscriptions have tended to take a larger and larger share of research library budgets at the cost of book purchasing, with non-serial expenditures falling relatively if not absolutely. A shift away from subscription journal publishing may free up research library funds and enable them to increase book purchasing. In turn, this could have a significant impact on book publishing costs (*e.g.* reducing unit costs by increasing print runs), and on the ability of humanities and social science scholars to get published.

---

<sup>32</sup> Pinfield (2007) demonstrates that arXiv has no impact on either use of journals or subscriptions.

<sup>33</sup> Drawing the distinction between raw versus value-added or unrefined versus refined data, Newbery and Bently (2008) concluded that in most cases a marginal cost pricing regime [which, for most digital data will be zero] would be welfare improving – that is that the benefits of moving to a marginal cost regime outweighed the costs.



- Book publishing costs could also be reduced with increased OA publishing of books and a consequent use of OA repositories for the distribution of books and/or book chapters online.
- OA institutional book publishing (*i.e.* e-Presses) may also enable greater visibility for the institution and enable humanities and social science scholars to get published (on the basis of merit rather than marketability). This may also create opportunities for priced overlay services, such as print-on-demand (Steele 2008).

## The flow of funds

Funding flow differences between the alternative journal publishing models relate primarily to differences between reader-side and author-side payments.

**Intra-university:** Subscriptions have typically been paid from block grant funds through the library, whereas author-pays fees might flow from researchers and/or their departments, from project grants funding or from block grants. The membership model of ‘author-pays’ may simplify the transition if research libraries handle the membership. An institution may also establish and operate an author-pays fund (*e.g.* The University of Nottingham).

Sponsorship or other OA publishing models may also impact on the flow of funds, with universities, departments or research institutions sponsoring a journal’s operation from internal funding. Institutional repository (and archive – *e.g.* arXiv) costs will tend to fall to the research centres and universities.

**Inter-university:** A shift from reader-side to author-side payments implies a relatively higher cost for intensive producers of journal articles (*e.g.* research intensive universities) and a relatively lower cost for less research oriented universities (*e.g.* universities that do not produce many journal articles or are teaching (*i.e.* use) intensive).

This issue may be addressed through adjustment to block grant allocation formula (if sufficiently material to warrant such a change), and does not arise where funder and/or funding agency support is offered for publishing (*e.g.* the research intensive universities are likely to win a larger share of grants and conduct a larger share of grant supported research).

**Extra-university:** A shift from reader-side to author-side payments also implies a shift from user-pays to producer-pays, with external non-university users of research getting free access to the literature under an OA publishing model and/or self-archiving (*e.g.* medical practitioners, pharmaceutical industry researchers, etc.).<sup>34</sup>

This may raise the operational costs of research organisations, depending on the relative costs of subscriptions versus author-side payments to those organisations. It will reduce the costs of user organisations in industry, government and elsewhere, thereby, reducing the costs of R&D and its commercialisation.

---

<sup>34</sup> This is sometimes referred to as the ‘free rider’ problem. However, in so far as scientific knowledge is a public good, the ‘free rider’ is more a mechanism for realising a return on public investment in research than a problem.

**Publishers:** Funding flows to and from publishers are also affected by a shift from reader-side to author-side payments.

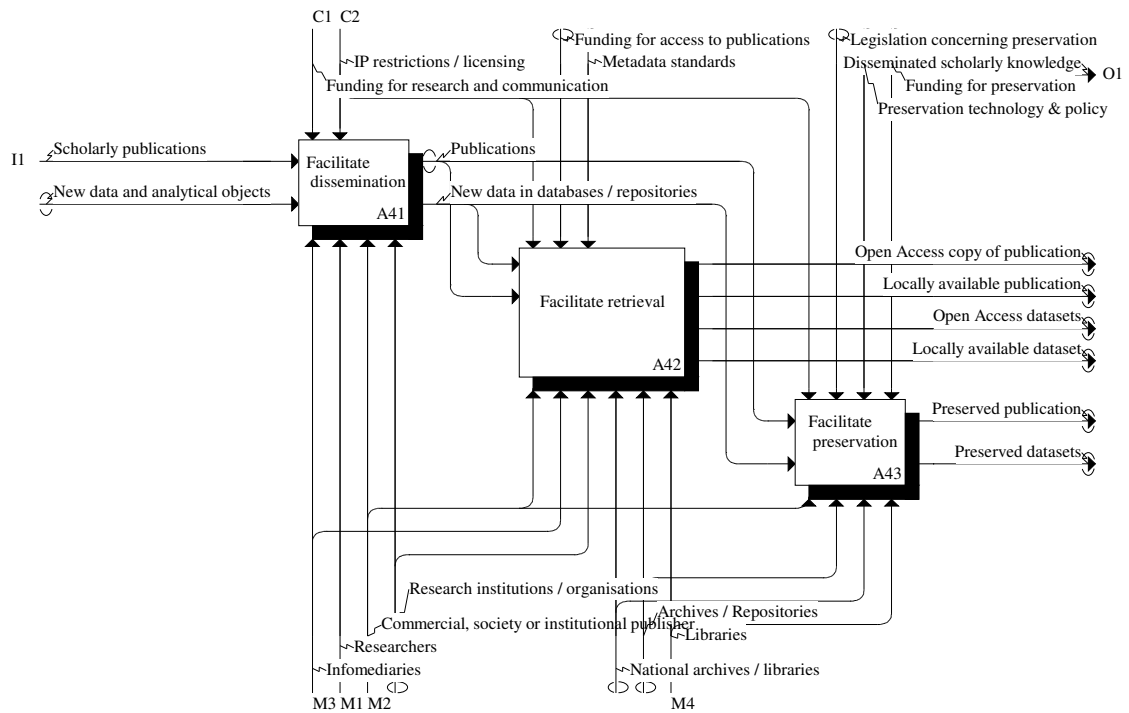
- OA publishing (especially author-pays) may well make revenue more predictable and stable, as it scales more easily to research output than have library budgets, growing with research expenditure and providing a revenue stream that is growing. This would reduced the level of risk and should, over time, be reflected in a reduced user cost of capital for OA publishers.
- OA publishers are less likely to need branded proprietary access systems, reducing the need for each publisher to develop expensive proprietary access systems, and reducing expenditure on IT skills and equipment while increasing the use of hosting services.
- OA journals are more visible and more useful, and are more likely to attract submissions and advertising revenue, thereby increasing potential revenue growth opportunities. Hybrid journals may also become more visible through offering open/author choice and grow subscriptions and subscription revenue as a result.
- Learned societies and associations may raise their profile, and that of their discipline, by publishing OA journals and/or hosting open access content (*e.g.* disciplinary OA repositories). This might contribute to membership growth and revenue growth. Learned societies and associations may also develop new revenue streams through the provision of overlay services to the open access content (*e.g.* peer review, specialist portals, etc.).

## 2.4 Facilitate dissemination, retrieval and preservation

Once scholarly work has been published it is essential to ensure effective dissemination, retrieval and preservation (Figure A4). Each of these activities is outlined in the following process model diagrams, and sub-activities are identified along with the controls, mechanisms, inputs and outputs involved in the process, in order to identify the major cost elements involved.

Extending the model outlined by Björk (2007), the inputs to the process are the publications, data and other digital objects, and the outputs are versions of the publications and datasets made locally available and/or freely available, and preserved for future use. Constrained by available funding and IP and licensing restrictions, a number of actors are involved, including: commercial, society and institutional publishers; researchers and research institutions; research libraries; national libraries and archives; and OA repositories. Informally communicated results, such as research reports, conference papers and presentations, blogs, wikis, etc. may also be more formally preserved and made available (*e.g.* The Internet Archive), but these have not been included in the process model for the sake of simplicity and because the activities, resources and processes involved are similar.

Figure A4: Facilitate dissemination, retrieval and preservation



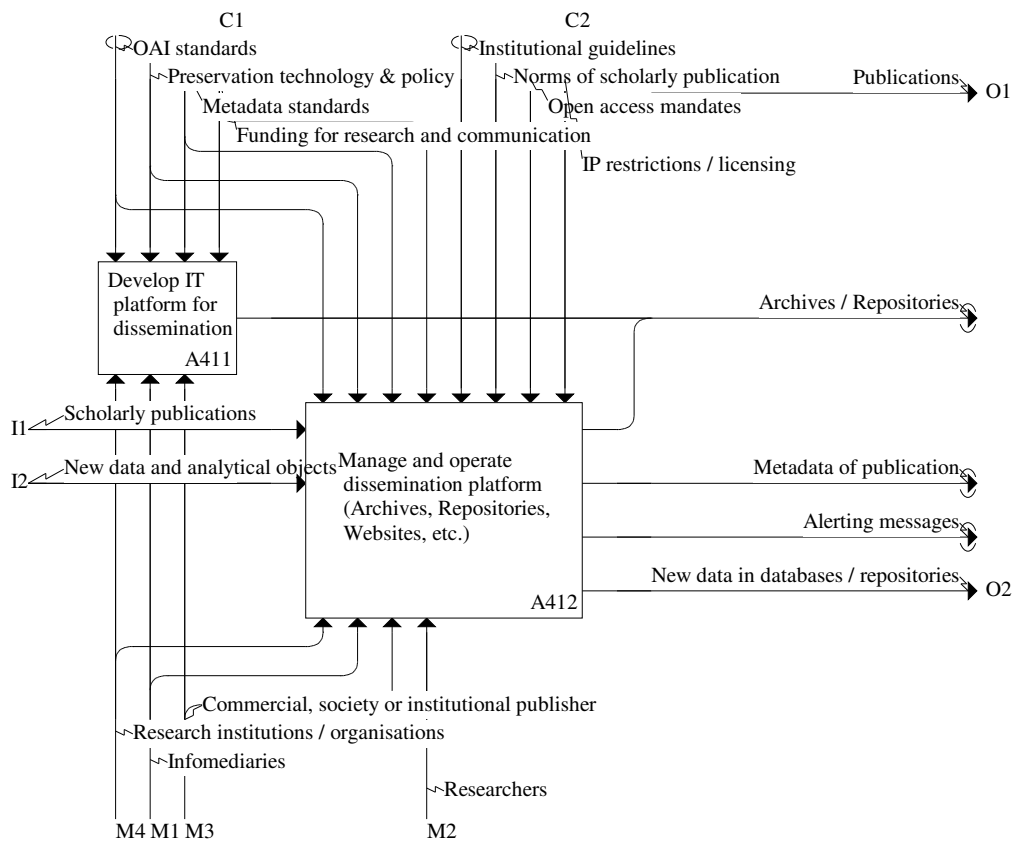
Link: <http://www.cfes.com/EI-ASPM/SCLCM-V7/>

Source: Scholarly Communication Process Model: Authors' analysis.

### 2.4.1 Processes involved in facilitating dissemination, retrieval and preservation

**A41: Facilitating dissemination** involves developing, operating and managing the platform for dissemination (Figure A41). Actors include commercial, society and institutional publishers, researchers, research organisations and infomediaries, with activities constrained by the funding available for research communication, IP licenses and agreements, the available technology and a range of guidelines and standards, such as metadata standards, institutional guidelines and OA mandates.

Figure A41: Facilitate dissemination

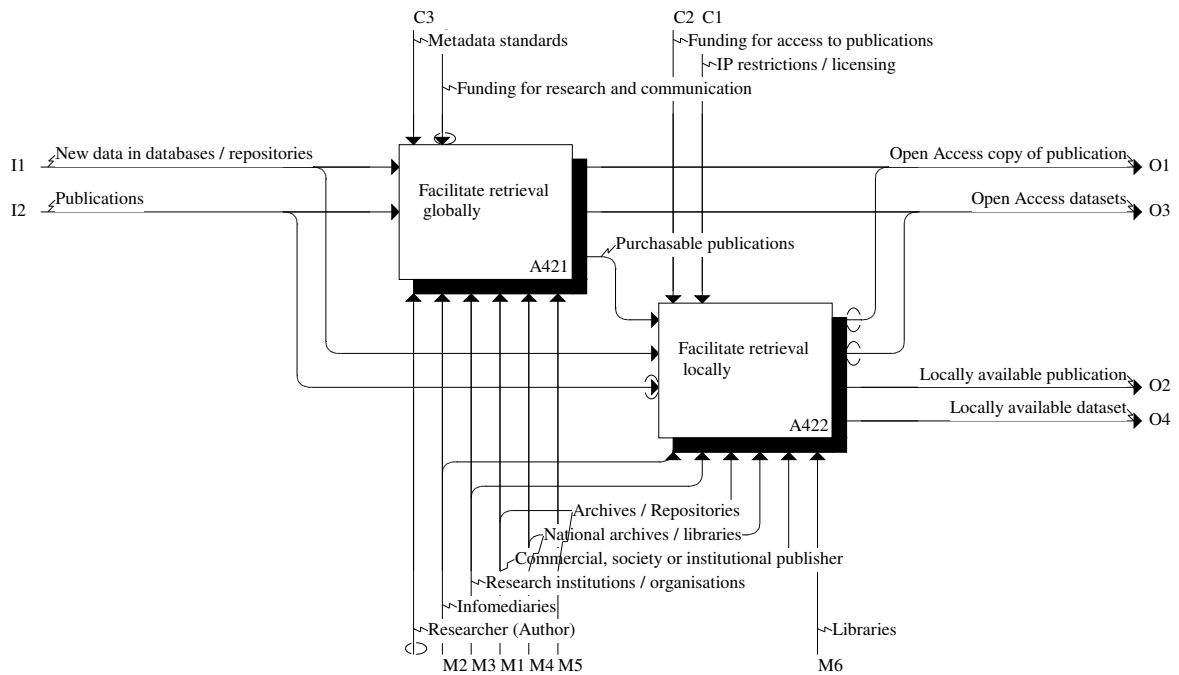


Link: <http://www.cfses.com/EI-ASPM/SCLCM-V7/>

Source: Scholarly Communication Process Model: Authors' analysis.

**A42: Facilitating retrieval** has both global and local elements, with the latter serving the needs of a closed community, such as a university's staff and students, by making published work available to that community (Figure A42). While there are significant differences in the activities and costs involved between print and electronic formats, the following analysis focus on differences between publishing business models (notable toll versus open access).

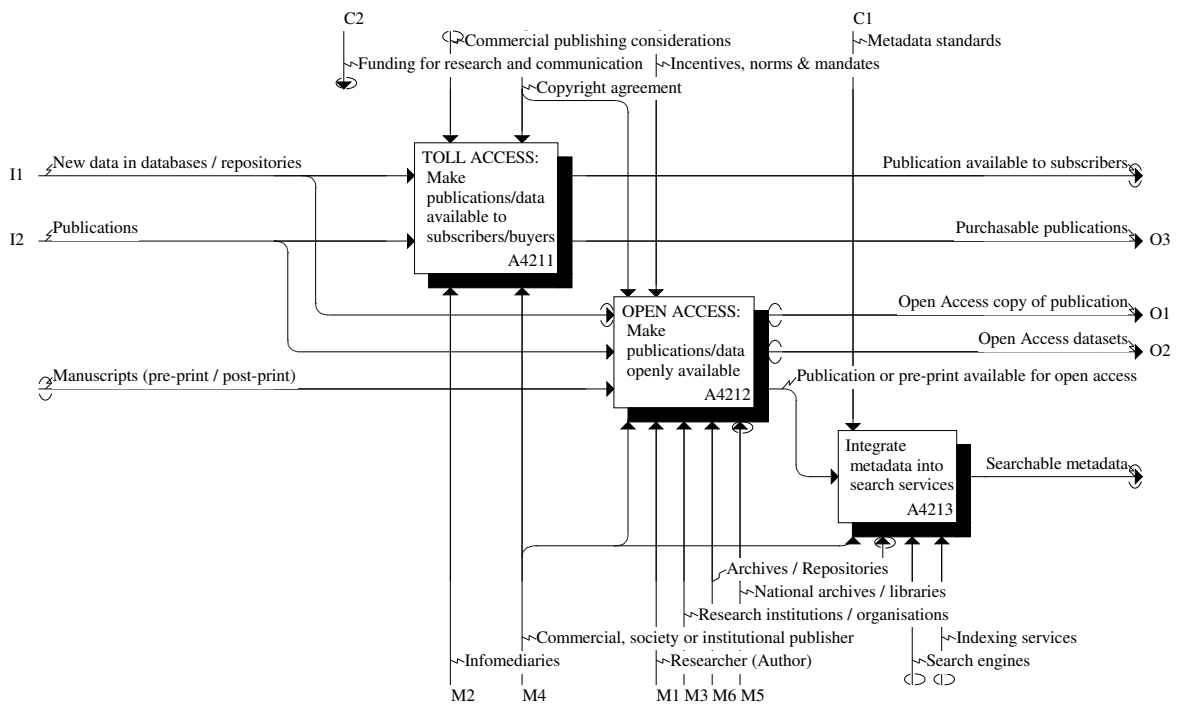
Figure A42: Facilitate retrieval



Link: <http://www.cfes.com/EI-ASPM/SCLCM-V7/>

Source: Scholarly Communication Process Model: Authors' analysis.

Figure A421: Facilitate retrieval globally



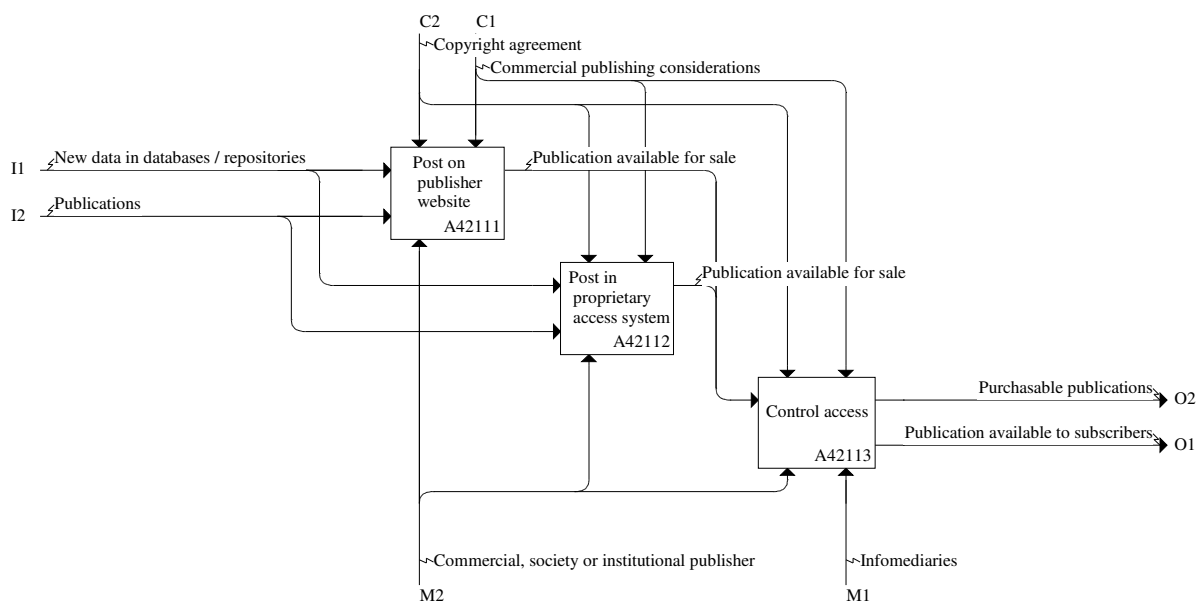
Link: <http://www.cfes.com/EI-ASPM/SCLCM-V7/>

Source: Scholarly Communication Process Model: Authors' analysis.

**A421: Facilitating retrieval globally** differs between toll and open access, and involves making publications and/or data available to subscribers/buyers constrained by copyright and licensing agreements, or making them openly available on the Internet depending on publishing model. The need to facilitate the integration of metadata into search services applies to all forms of content and publishing models (Figure A421).

**A4211: Toll Access - Making publications or data available to subscribers/buyers** involves putting them on a publisher website or into a proprietary access system, depending on commercial publishing considerations. In either case, controlling access and authentication of subscribers is crucial. This can be done by the commercial, society or institutional publishers themselves or be left to intermediaries.

Figure A4211: Make publications or data available to subscribers/buyers



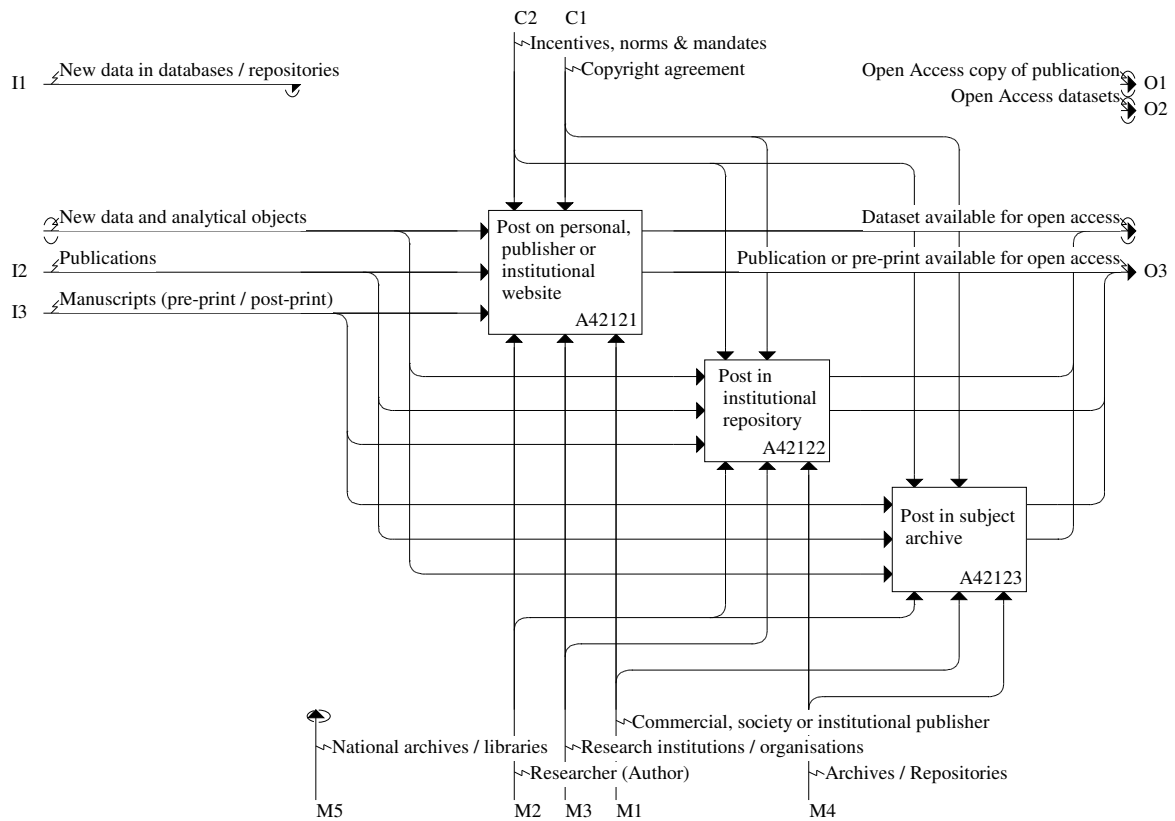
Link: <http://www.cfses.com/EI-ASPM/SCLCM-V7/>

Source: Scholarly Communication Process Model: Authors' analysis.

**A4212: Open Access - Making publications or data openly available** might involve posting them on a personal, publisher or institutional website, an institutional or subject repository (Figure A4212). This involves researchers, research institutions and publishers in the use of the Internet, e-print repositories, etc. to make works freely available, subject to copyright agreements, incentives, norms and OA mandates.

As noted, there can be cost differences between restricted and open access systems. There are also substantial differences between the costs of making e-prints available and making research datasets available, with the latter costs much higher than the former.

Figure A4212: Make publications or data openly available

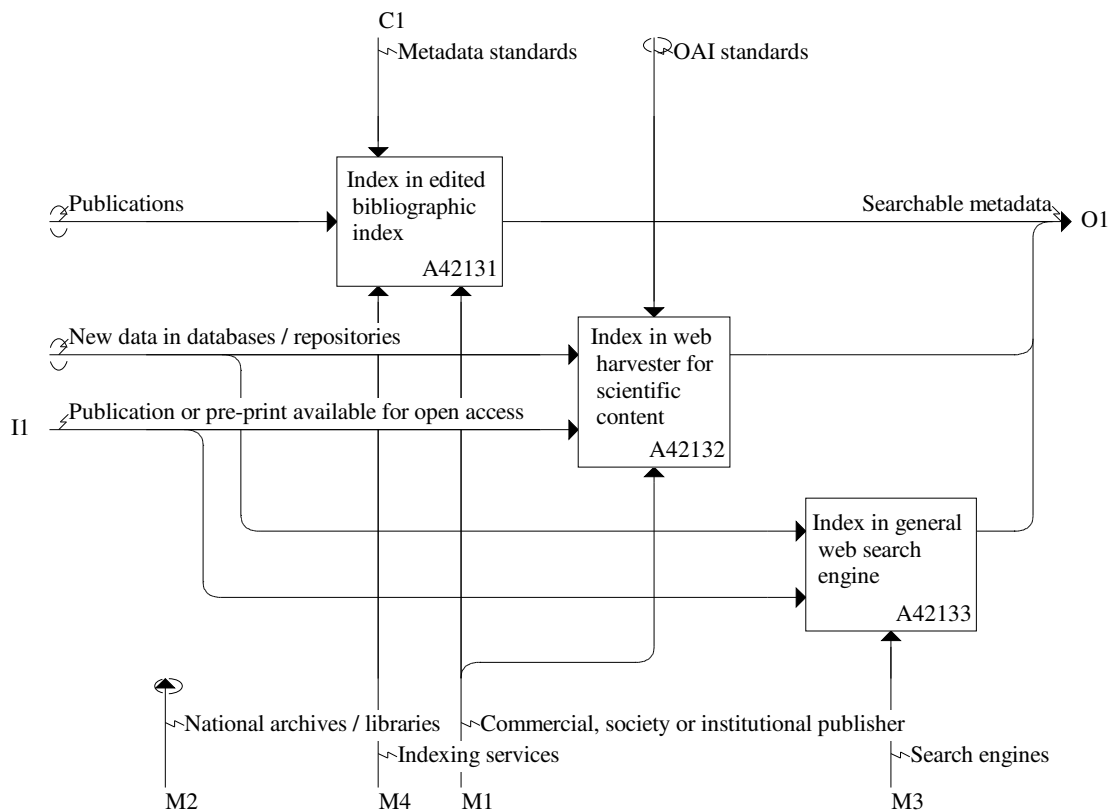


Link: <http://www.cfses.com/EI-ASPM/SCLCM-V7/>

Source: Scholarly Communication Process Model: Authors' analysis.

**A4213: Integrating metadata into search services** involves commercial, society or institutional publishers and indexing services indexing in edited bibliographic indexes, web harvesters focusing on scholarly content and/or general web search engines, according to established metadata practices and standards, etc. (Figure A4213).

Figure A4213: Integrate metadata in search services



Link: <http://www.cfses.com/EI-ASPM/SCLCM-V7/>

Source: Scholarly Communication Process Model: Authors' analysis.

**A422: Facilitating retrieval locally** to a closed community is constrained by funding for access to publications (*e.g.* research library budgets) and IP/copyright and license agreements in the case of toll access publishing models (Figure A422).<sup>35</sup>

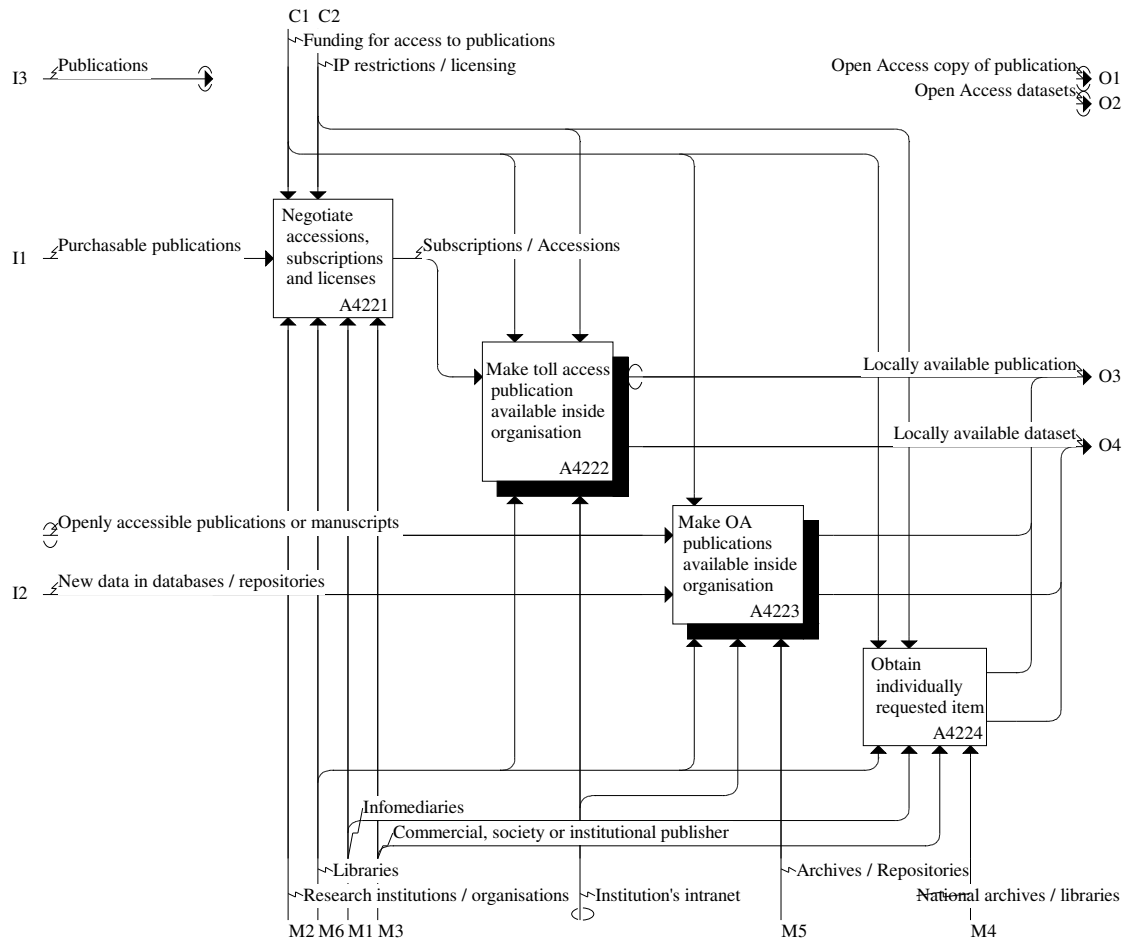
For toll access publications, it involves research and institutional libraries, research institutions, publishers and infomediaries negotiating subscriptions and licenses, and, subject to agreements, making the publications or datasets available inside the organisation. Authentication and access controls must be implemented and operated in order to restrict access to local 'community' members (*e.g.* a university's staff and students, the staff of a particular firm or government department, etc.). Making OA publications available locally does not require the negotiation of subscriptions and licenses or the operation of authentication and access controls.

Toll access publications made locally available are often supplemented by one-off delivery of items requested through ILL and document delivery services, provided by national and deposit libraries, publishers and other infomediaries.

<sup>35</sup> For the sake of simplicity and focus, a number of research library activities have been omitted. These include collection development, circulation and stacks maintenance (*e.g.* current issues shelves), etc. However, these non-subscription activities can involve substantial costs (Schonfeld, *et al.* 2004a; 2004b) and are discussed during the quantification of costs in Part II.



Figure A422: Facilitate retrieval locally



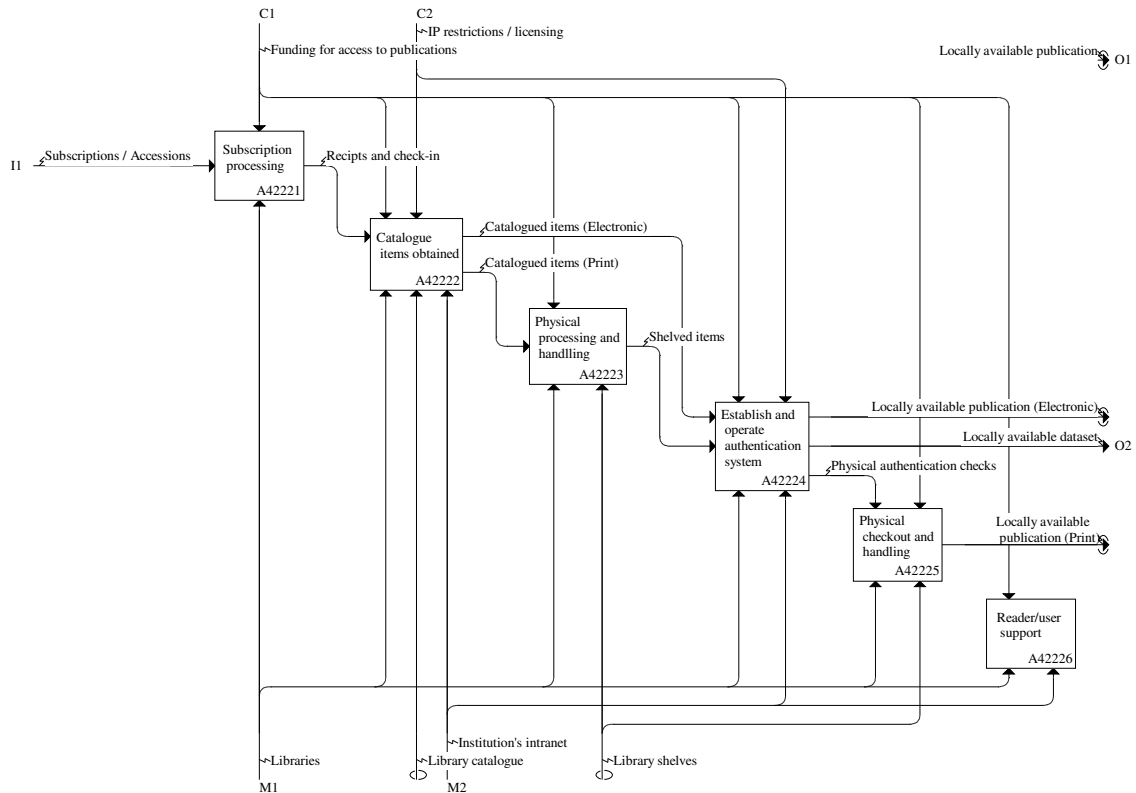
Link: <http://www.cfses.com/EI-ASPM/SCLCM-V7/>

Source: Scholarly Communication Process Model: Authors' analysis.

**A4222: Making toll access publications available internally** involves additional effort on the part of research and institutional libraries (Figure A4222). These include: subscription processing, cataloguing items, physical handling of print material (*e.g.* shelving), establishing and operating an authentication system (*e.g.* library membership, student or staff card for physical authentication and/or a user login and password for logical authentication, etc.), physical checkout and handling for print material and reader/user support (*e.g.* user instruction and support, reference and research).

The physical handling aspects of this work (*e.g.* shelving and re-shelving, check-out handling, etc.) are unnecessary under an electronic publishing model, with potentially substantial cost savings (See, for example, Schonfeld *et al.* 2004a; 2004b).

Figure A4222: Making toll access publications available internally

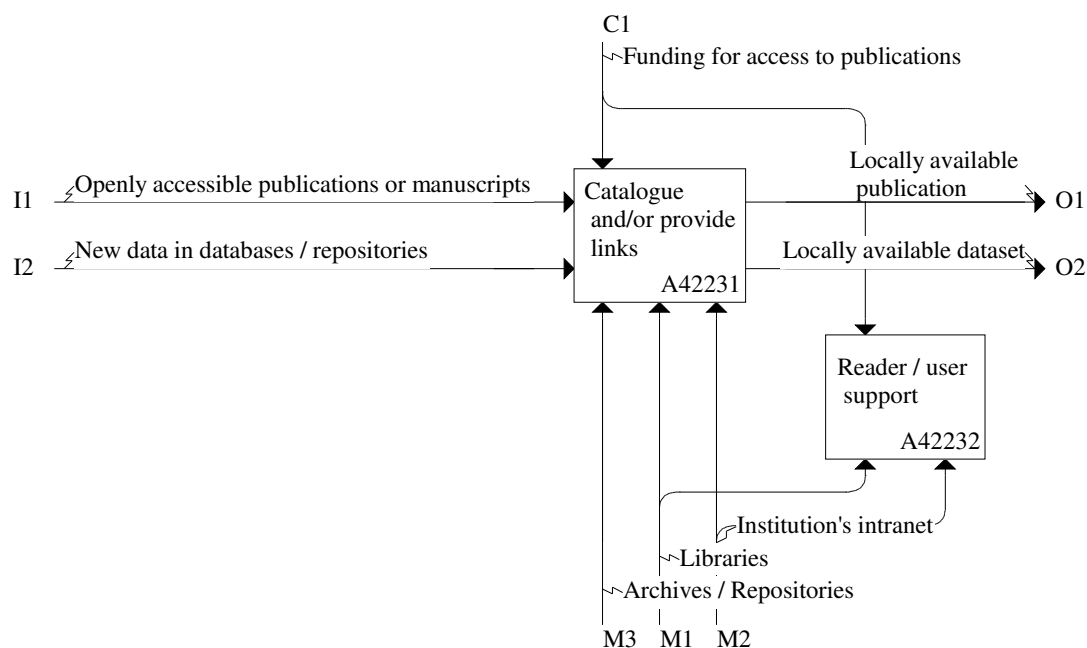


Link: <http://www.cfses.com/EI-ASPM/SCLCM-V7/>

Source: Scholarly Communication Process Model: Authors' analysis.

**A4223: Making open access publications available internally** demands less effort on the part of research and institutional libraries (Figure A4223). Core activities can be limited to cataloguing and/or providing links to OA content, and providing reader/user support. OA publishing and self-archiving models do not require such activities as subscription processing, establishing and operating an authentication system or checkout and handling. As result, there is potential for substantial cost savings.

Figure A4223: Making open access publications available internally



Link: <http://www.cfses.com/EI-ASPM/SCLCM-V7/>

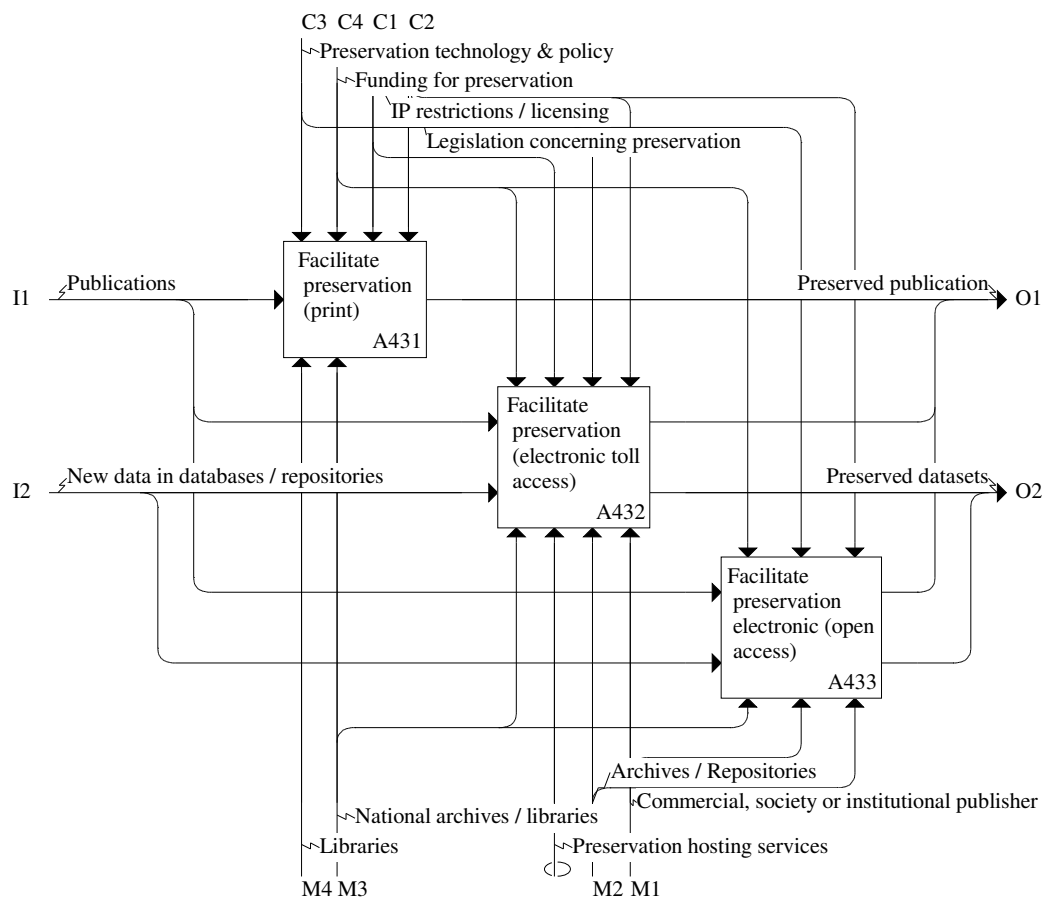
Source: Scholarly Communication Process Model: Authors' analysis.

**A43: Facilitating preservation** varies between publishing models and whether or not the content is print or electronic (Figure A43). Preservation of print involves ongoing custodianship of materials by research and national libraries, with all the attendant costs of shelving and maintenance (*e.g.* re-binding, etc.). Preservation of electronic content also involves the publishers and/or specialist preservation hosting services (*e.g.* JSTOR) in the case of toll or hybrid access materials, and OA repositories in the case of OA self-archived materials.<sup>36</sup> OA published content (*i.e.* Gold OA) can present an additional challenge.

To date, relatively little attention has been paid to the long-term preservation of electronic and/or OA content, although it is clear that preservation costs are likely to be substantial. However, those costs are unlikely to vary greatly between publishing model (*e.g.* between toll and open access).

<sup>36</sup> OA repositories can, therefore, host and preserve toll access material when it has been self-archived (*i.e.* Green OA).

Figure A43: Facilitate preservation



Link: <http://www.cfses.com/EI-ASPM/SCLCM-V7/>

Source: Scholarly Communication Process Model: Authors' analysis.

### 2.4.2 Identification of the costs involved in facilitating dissemination, retrieval and preservation

The analysis of costs relating to dissemination, retrieval and preservation found in the literature is extensive, but is rarely integrated into broader analysis of the overall scholarly communication process. Some of the activities and costs are integral to the publishing process and are a part of publisher costs, but many others are not. These later include a range of research library, preservation and supporting systems costs.

There are major cost differences involved in a print versus online publishing environment (and in the operation of dual-mode delivery), which are intertwined with alternative models of scholarly publishing. Print delivery involves physical dissemination, including packaging and delivery, cataloguing, shelving, retrieval and re-shelving, etc. Online delivery involves the development and operation of IT systems and platforms for dissemination, be they publishers' proprietary systems or open repository systems, be they integrated systems adding search and discovery capabilities to basic access or more simple systems based around open standards that

facilitate the operation of a wide range of overlay functions and services. Online delivery has moved some of the access functions performed by libraries in the print era back up the value chain to publishers and hosting services, and their supporting IT systems and services.

Extensive reviews of the literature on the costs of dissemination, retrieval and preservation, and identification of those costs, have been presented in:

- Halliday, L. and Oppenheim, C. (1999) *Economic Models of the Digital Library*, eLib, United Kingdom Office of Library and Information Networking.
- Tenopir, C. and King, D.W. (2000) *Towards electronic journals: realities for scientists, librarians and publishers*, SLA Publishing, Washington DC.
- Schonfeld, R.C., King, D.W., Okerson, A. and Fenton, G.E. (2004) *The non-subscription side of periodicals: changes in library operations and costs between print and electronic journals*, Council on Library and Information Resources, Washington DC.
- Houghton, J.W. Steele, C. and Sheehan, P.J. (2006) *Research Communication Costs in Australia, Emerging Opportunities and Benefits*, Department of Education, Science and Training, Canberra.
- EPS, et al. (2006) *UK scholarly journals: 2006 baseline report – An evidence-based analysis of data concerning scholarly journal publishing*, Research Information Network, Research Councils UK and Department of Trade and Industry.
- Bailey, C.W. et al. (2006) *Institutional Repositories*, SPEC Kit 292, ARL, Washington DC.
- Björk, B-C. (2007) 'A model of scientific communication as a global distributed information system,' *Information Research* 12(2) paper 307.
- Universities UK (2007) *Publishing research results: the challenges of open access*, Policy Briefing, Universities UK, London, April 2007.
- Weenink, K., Waaijers, L. and van Godtsenhoven, K. (2008) *A DRIVER's Guide to European Repositories*, Amsterdam University Press.
- Beagrie, N., Chruszcz, J. and Lavoie, B. (2008) *Keeping Research Data Safe: A cost model and guidance for UK universities*, A report by Charles Beagrie for JISC.

Research library costs are substantial, and while quite different in print and online environments typically remain significant – especially with toll access publishing. Acquisition costs have been a major element of cost in the toll access publishing environment, but non-acquisition costs have been larger. These include library and access infrastructure (e.g. catalogues, IT systems, shelving, etc.), purchasing and negotiation activities, handling licensing and legal issues, setting up and managing authentication and identification systems, other staff costs, buildings and facilities, overheads, etc. These research library acquisition and non-acquisition costs are widely reported.

A number of analysts have pointed to the significance of research library non-acquisition costs. Odlyzko (1998) went so far as to suggested that the 'journals crisis' was really a library costs crisis, claiming that for every USD 1 spent on journals a further USD 2 was spent on library processing and storage costs. A ratio of around 2 to 1 is often seen in the literature, with

acquisitions accounting for around 33% of reported research library costs in various countries around the world. In the UK, SCONUL reported total member library expenditures of £597 million in 2006-07, of which £205 million (34%) was on acquisitions (SCONUL 2008).

Citing a number of previous studies, Tenopir and King (2000, p216) suggested that the unit cost of processing and maintaining purchased journals had been estimated at USD 71 per title for university libraries and USD 81 for special libraries in the late 1990s. To these fixed costs one should add usage costs (*e.g.* re-shelving), which were estimated at USD 1.05 per reading for university libraries and USD 1.48 for special libraries. Schonfeld *et al.* (2004a, p27; 2004b) found that a sample of US research libraries' 25 year life-cycle costs per title varied from USD 48 to USD 353 for print journals, compared with USD 12 to USD 69 for electronic journals – with savings arising from reduction of library shelving and handling costs. Among the relatively few to focus on book related costs, Lewis (2004) cited library processing costs for a hypothetical library of USD 50 for print monograph processing, compared with USD 25 for e-book processing.<sup>37</sup>

Hosting, preservation and archival costs are also significant, with costs relating to storage and accessibility, ongoing maintenance of the material and supporting systems, etc. as well as the underlying policies, standards and systems. Publishers have invested heavily in their digital delivery platforms (*e.g.* Fisher 1997; Shirrell 1997; Day 1998; Hunter 1998). Indicative of the systems costs for large publishers, Worlock (2004) reported that Elsevier had invested at least £45 million in its ScienceDirect service over the preceding five years. Davis (2004) reported to a House of Commons Committee that Elsevier's ScienceDirect had cost £200 million to develop and required ongoing investment of well over £100 million.

Comparing print and electronic publications costs, Fisher (1997) concluded: "It seems that the direct costs of publishing an electronic journal are substantially below that of a print journal with comparable pages. The overhead costs, however, are much higher." Specific areas of additional costs cited in the literature include: unexpectedly high customer support costs, with support staff requiring sophisticated and expensive technical skills; additional costs associated with licensing online content, with complex licensing agreements; additional marketing costs, with the complexity of the product increasing; and additional metadata costs, with the production of richer metadata (The National Academies 2004).<sup>38</sup> By becoming the source or host site publishers have taken on some of the functions performed by libraries in the print environment, and with them some of the costs (Halliday and Oppenheim 1999, p48).

Reports of the installation and operational costs of OA repositories vary considerably, with what is included and what is assumed to be covered within the overhead costs of the hosting institution varying from case to case (*e.g.* Hickerson 2004; Swan and Brown 2005; Kemp 2005; Swan *et al.* 2004; Swan and Needham 2005; Bailey *et al.* 2006; Universities UK 2007). The scope of the archive/repository may also vary considerably, with some catering for e-prints only and offering limited functionality, while others embrace a much wider range of digital objects

---

<sup>37</sup> Most analysts focus on differences between print and electronic publishing rather than those between toll and open access publishing.

<sup>38</sup> Many of these assume subscription publishing and could be reduced or in some cases avoided with OA publishing.

and seek to integrate more fully into teaching and learning, research management and reporting functions. Based on a wide ranging review of the literature and local case studies, Houghton *et al.* (2006, p19) suggested that when all expenditures and staff time were included annual repository costs in Australian universities would probably be up to some AUD 275,000 for a relatively simple e-prints repository. In a survey of planners and implementers of institutional repositories in the US, Bailey *et al.* (2007) also reported a wide range of costs, with average start-up costs of the order of £32,580 and ongoing operational costs of £47,463 per year. Universities UK (2007) also reported annual repository costs of around £40,000, and Swan (2008a) reported DRIVER repository costs of the order of £30,000 to £100,000 per annum (average £65,000).<sup>39</sup>

Long-term preservation, be it in print or digital form, also involves costs, with a number of bodies and studies focusing on these – see, for example, the Digital Preservation Coalition (<http://www.dpconline.org/>). Exploring acquisition, ingest, metadata, access and storage costs relating to arXiv at Cornell, Kenney (2005) looked at costs relating to systems, staff, ancillary staff expenses, services and fees, supplies and materials. She suggested that systems costs accounted for less than 2%, staff for around 50%, ancillary staff and contingency costs less than 10%, with overheads accounting for the remainder of the estimated total annual cost of USD 305,333. Longer-term preservation faces additional costs relating to technology monitoring and migrating to ensure that material remains accessible in terms of formats *and* access software and systems (Wheatley, *et al.* 2007).

Beagrie *et al.* (2008) explored the costs of digital curation of research data, noting that the costs of data repositories are an order of magnitude greater than that suggested for institutional repositories focused on e-prints alone – with annual staff costs two to four times greater and equipment and systems costs as much as twenty to forty times greater, driven in large part by higher staffing levels and user support and much larger storage requirements. The study provides detailed descriptions of cost elements, in terms of costs relating to staff, equipment, travel, consumables, estate and indirect costs. For data centres operated by UK research councils, Beagrie *et al.* (2008, p66) note that the distribution of costs by functions is similar across the councils and fields – with acquisition and ingest accounting for 42% of overall costs, archival storage and preservation for 23% and access 35% (See also Lyon 2007).

Referring to toll access publishing models, Halliday and Oppenheim (1999, p48) noted that negotiating license terms requires expertise, and takes a great deal of time. Management of IP and licensing, applying for and granting permissions, the development and implementation of related guidelines, etc. can involve substantial costs for authors, publishers, libraries and other users (Halliday and Oppenheim 1999, p35). Abstracting, indexing and bundling can also involve substantial costs, as can posting and self-archiving the content itself. Moreover, all of these depend on underlying resources which each involve substantial costs (*e.g.* internal and external IT infrastructure, equipment and systems, the operation of national facilities such as libraries, archives and museums, and a range of institutional support).

---

<sup>39</sup> Studies on e-print repository costs show similar cost levels around the world, once account is taken of if and how they treat in-kind and overhead costs.

Table 2.7: Dissemination, retrieval and preservation: major cost items

| <i>Activity/Item</i>                                     | <i>Description</i>   |
|--|--|
| <b>Dissemination:</b>                                    |  |
| Develop of proprietary IT platform                       | Costs associated with the development of proprietary publisher access platform, including skills, software, hardware, etc.   |
| Operation of proprietary IT platform                     | Costs of ongoing operation of proprietary publisher platform, including updates and upgrades, etc.   |
| Develop of open IT platform                              | Costs associated with the development of an OA archive/repository, including skills, software, hardware, etc.  |
| Operation of open IT platform                            | Costs of ongoing operation of an OA archive/repository, including updates and upgrades, etc.   |
| Operation of generic platform (Internet)                 | Costs of ongoing operation of websites, etc.   |
| Standards  | Development, promulgation, adoption and implementation of standards (e.g. metadata).   |
| Guidelines   | Development and enforcement of guidelines, mandates, etc.  |
| Licenses and agreements                                  | Development and ongoing negotiation and amendment of license agreements.   |
| <b>Retrieval:</b>  |  |
| Bundling and packaging                                   | Costs of bundling and packaging into e-sources and products.   |
| Abstracting and indexing                                 | Costs relating to abstracting and indexing, integrating into bibliographic indexes, specialist search services and generic search engines.   |
| Posting/self-archiving                                   | Costs of posting to website, repository, etc. (e.g. researcher or other time) for self-archiving model.  |
| Library facilities                                       | Library facilities, including: staffing, buildings, shelving, IT systems, operational expenses, etc.   |
| <i>Acquisition costs</i>                                 | <i>Serials and non-serial acquisition costs.</i>   |
| <i>Non-Acquisition costs</i>                             | <i>Library and access infrastructure, purchasing and negotiation, licensing and legal, processing and handling, authentication and identification, reader/user support, staff costs, buildings and facilities, overheads, etc.</i> |
| Document delivery/ILL                                    | Costs of document delivery and ILL (for toll access model).  |
| Copyright collections                                    | Costs of copyright collection agency charges and their collection and management (for toll access model), and operation of collection agencies.  |
| <b>Preservation:*</b>                                    |  |
| Preservation and archival costs (print)                  | Costs relating to handling and storage, ongoing maintenance of material and supporting systems, etc. to provide longer-term preservation and access.   |
| Preservation and archival costs (electronic toll access) | Costs relating to handling and storage, ongoing maintenance of material and supporting systems, IP and licensing, access control, etc. to provide longer-term preservation and access.   |
| Preservation and archival costs (electronic OA)          | Costs relating to ongoing handling and storage, and maintenance of supporting systems to provide longer-term preservation and access to e-prints.  |
| Preservation and archival costs (Data)                   | Costs relating to handling and storage, ongoing maintenance of material and supporting systems, IP and licensing, access control, etc. to provide longer-term preservation and access to data.                                     |
| <b>Resources:</b>  |  |
| IT support infrastructure                                | Internal and external IT infrastructure, equipment and systems.  |



| <b>Activity/Item</b>                        | <b>Description</b>   |
|---|--|
| National Libraries, archives, museums, etc. | Operation of national facilities.  |
| Other institutional support                 | Institutional support (e.g. university IT services, personnel and management, etc.). |

Note: \* These cost elements can be further decomposed, as noted above.

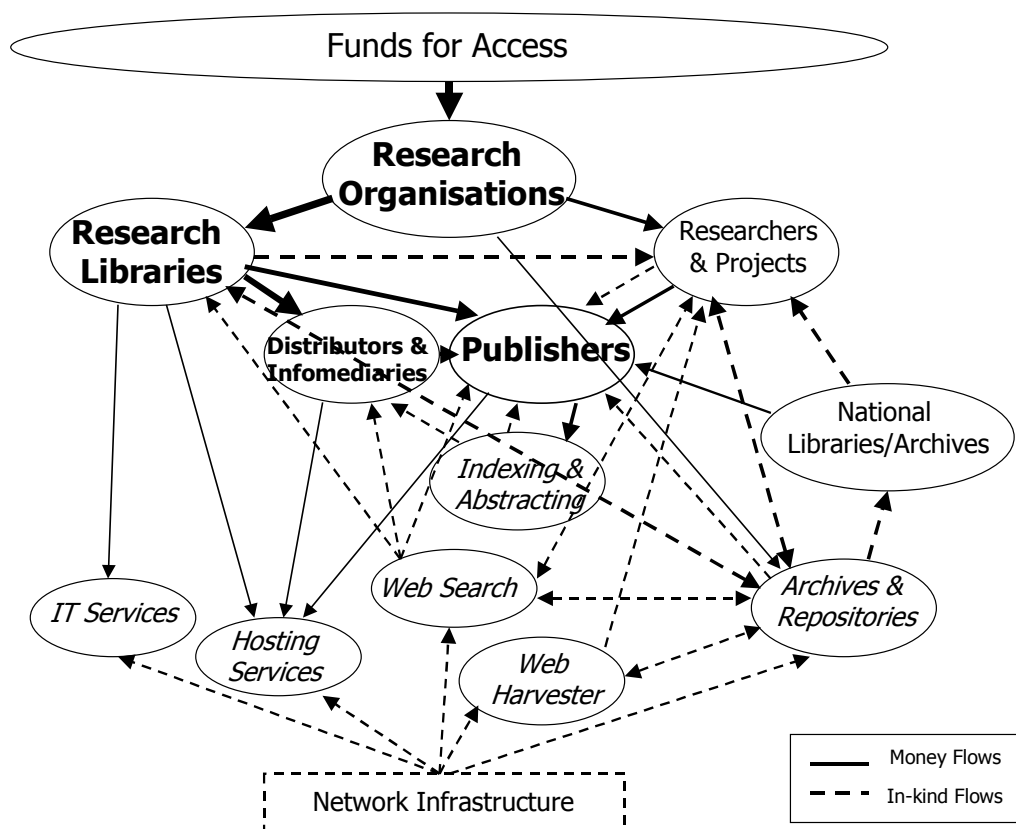
Source: Authors' analysis.

Table 2.7 presents a summary of the major cost items identified, based on the process model outlined above and a brief review of the literature.

### 2.4.3 Funding flows relating to dissemination, retrieval and preservation

Funding flows in dissemination, retrieval and preservation involve a range of sources, such as research library budgets and funding for subscription and document delivery payments, as well

Figure 2.6: Simplified funding flows relating to facilitating dissemination, retrieval and preservation



Dissemination, Retrieval & Preservation

JISC EI-ASPM 2008

Source: Authors' analysis.

as a range of implicit institutional and wider support for intranets and the Internet, national libraries and archives, as well as various forms of commercial support (*e.g.* advertising support for generic web search engines). Toll access publishers rely on subscription and other revenues to support indexing activities while others rely on author-side revenues, institutional or other forms of support.

#### 2.4.4 *The impacts of alternative publishing models on dissemination, retrieval and preservation activities*

While there are major cost differences and cost shifts involved in a move from print to online scholarly publishing, we focus on those relating to online delivery as both Big Deal subscription and OA publishing are predicated on online delivery. In this way we aim to disentangle the issues relating to electronic versus print publishing from those relating to toll versus open access publishing, so often mixed together in the literature (and sometimes mixed up).

#### Costs and impacts

The main areas of cost impact include:

- IP and licensing – costs associated with negotiating agreements, permissions to make available for use, etc. affecting publishers and libraries (*i.e.* costs may go down because less need for such activities with OA publishing, or increase as there may be more variety in publishing models and greater complexity).
- Copyright collection and management costs – reduction/elimination of copyright collection agency payments with OA publishing, and in the management of those payments. Also reduced operational costs for copyright collection agencies and, indirectly, for publishers.
- Proprietary access systems – costs associated with the duplication of access systems development and operational efforts, the imposition of access controls (*e.g.* authentication), etc. with toll access publishing, and possible cost reductions with OA publishing.<sup>40</sup>
- Library acquisition costs – subscription costs versus author-side or sponsor payments with toll access and OA publishing, respectively.
- Library acquisition costs – competition between self-archived (Green OA) papers and the toll access journal equivalent, as close substitutes, should put downward pressure on subscription prices (Bergstrom and Lavaty 2007).
- Document delivery and ILL – reduction/elimination of document delivery, ILL and reprint costs with OA publishing and/or self-archiving.

---

<sup>40</sup> Opportunity costs apply equally to consumers, and the imposition of these costs (*e.g.* in dollars and time) on information users can reduce the social net benefit of an information product or services (Nilsen 2007).

## Economic implications of alternative scholarly publishing models

- Library non-acquisition costs – likely to be higher user support costs for the multiple proprietary systems that characterise toll access publishing than the open web-based systems that characterise OA.
- Institutional, departmental, library, etc. repositories – costs relating to the development, installation and operation of repositories (but may also reduce library costs).
- Posting/self-archiving – cost of self-archiving done by author, publisher or administrative staff, or all of these.
- Preservation – costs associated with preservation, which may be lower with distributed/federated repositories.
- Handling – costs associated with handling, with OA publishing operating as electronic publishing while toll access publishing can be either electronic or print or, more commonly, dual-mode, forcing duplication throughout the dissemination and preservation value chain.

## The flow of funds

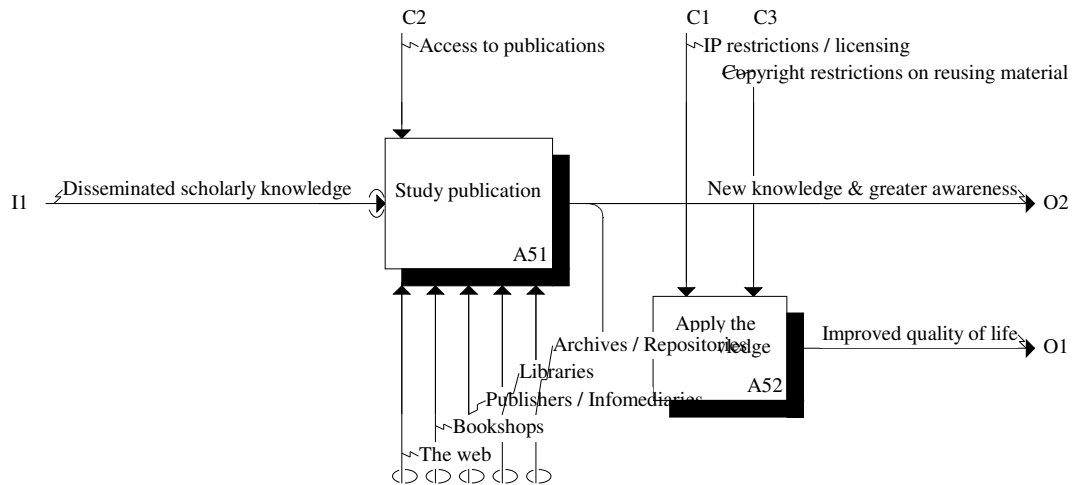
In addition to these possible costs and benefits, impacts on funding flows within dissemination, retrieval and preservation activities would be likely to revolve around:

- Possible reduction of library acquisition (subscriptions and book purchases) flows to publishers with OA publishing, and reduction in publisher subscription revenues;
- Possible shift of library costs relating to access issues and collections to repositories and self-archiving, and/or their elimination; and
- Possible shift of revenues between services and suppliers (*e.g.* reduction in IP and license negotiation costs for libraries and publishers with OA publishing, and increased IT systems costs leading to a shift from legal and para-legal to IT skills and services, etc.).

## 2.5 Study publications and apply knowledge

Scholarly publications are a vital mechanism for research communication, which while specialised are in some fields of research are often widely read by practitioners as well as other researchers in other fields. Developing the model outlined by Björk (2007), we suggest that studying publications depends on access and applying the knowledge may be constrained by IP restrictions and licensing conditions, such as copyright restrictions on reusing the material (Figure A5). At a detailed level the contexts of studying and applying knowledge vary from country to country, but the functions are relatively generic. As elsewhere, in so far as there are national differences, the following outline is intended to reflect activities in the UK.

Figure A5: Study publication and apply knowledge



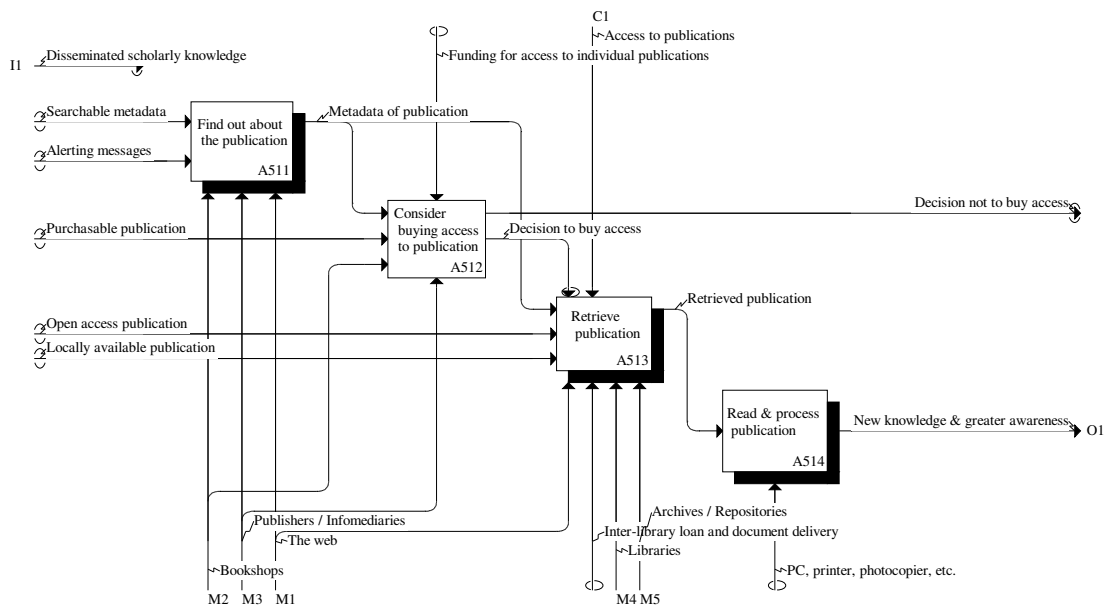
Link: <http://www.cfses.com/EI-ASPM/SCLCM-V7/>

Source: Scholarly Communication Process Model: Authors' analysis.

### 2.5.1 Processes involved in studying publications and applying knowledge

**A51: Studying a publication** involves finding out about it and retrieving it, mediated in the case of toll access by funding to pay for access and the decision of buy. Once retrieved the publication can be read and processed (Figure A51).

Figure A51: Study publication

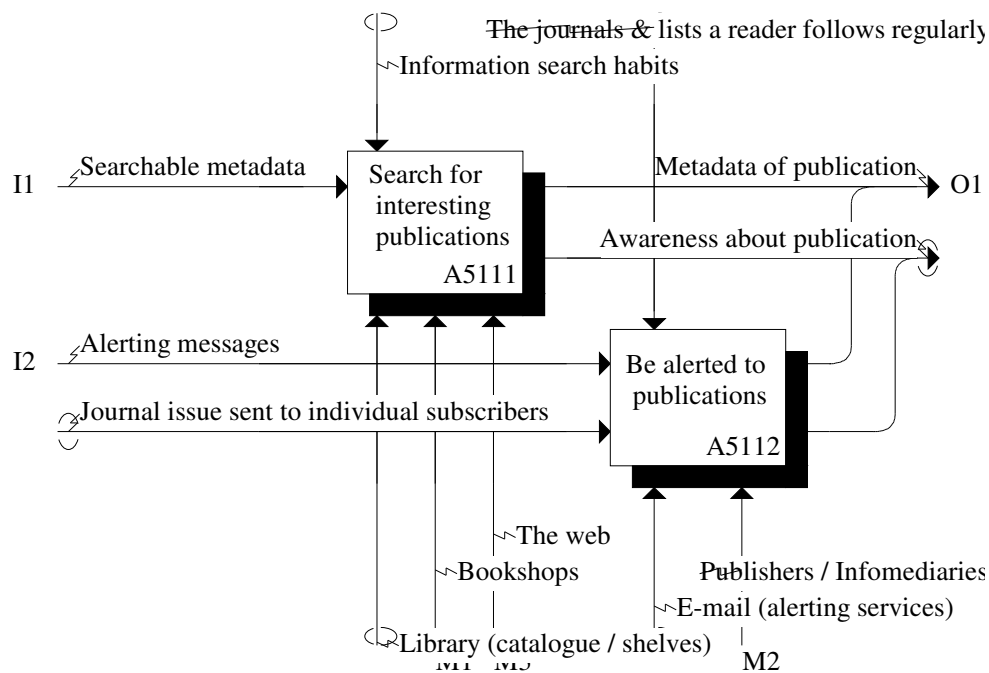


Link: <http://www.cfses.com/EI-ASPM/SCLCM-V7/>

Source: Scholarly Communication Process Model: Authors' analysis.

**A511: Finding out about the publication** can involve searching for interesting publications and/or being alerted to them (Figure A511). Searching depends on searchable metadata and is constrained by information search habits and the systems available, while being alerted depends on alert messages being sent and received, often constrained by the journals and lists a reader follows regularly. Mechanisms include library catalogues and shelves, the Internet, booksellers, e-mail alerting and list services, publishers and infomediaries.

Figure A511: Find out about the publication

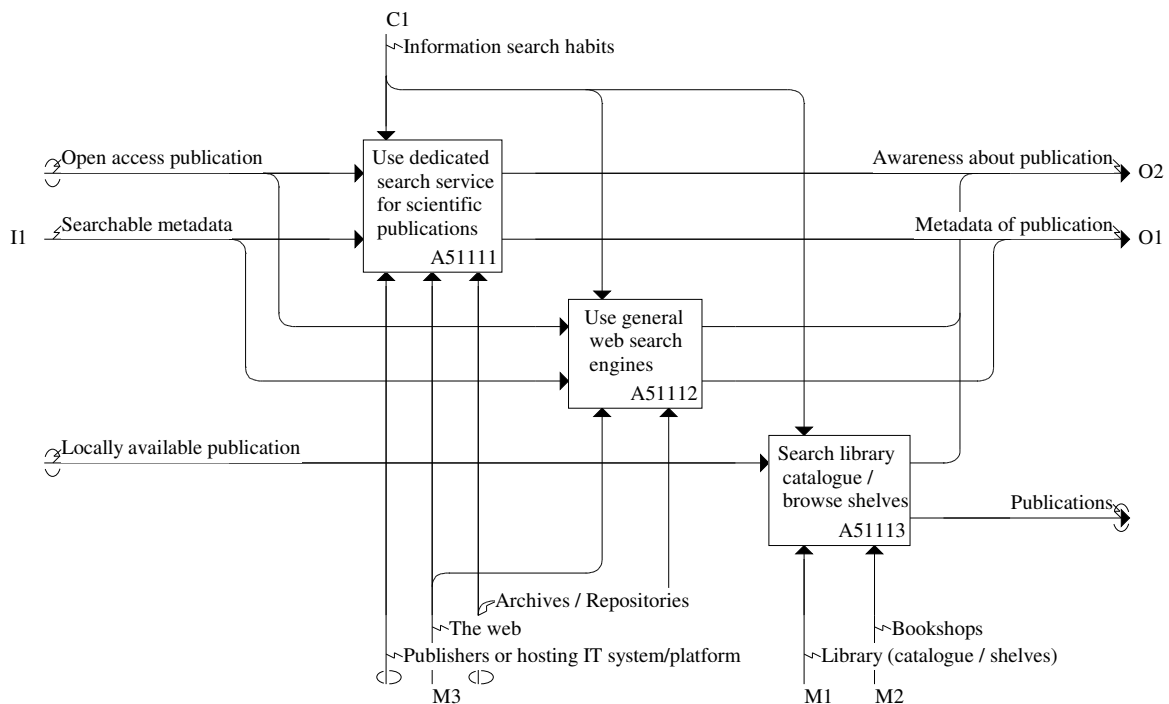


Link: <http://www.cfses.com/EI-ASPM/SCLCM-V7/>

Source: Scholarly Communication Process Model: Authors' analysis.

**A5111: Searching for interesting publications** can involve using dedicated search services, general web searches and/or library catalogues and even browsing shelves (Figure A5111). Information search habits constrain activities, and the activities depend on publishers' IT systems and platforms, open access archives and repositories, the Internet, library catalogues and shelves, booksellers and other information sources.

Figure A5111: Search for interesting publications



Link: <http://www.cfses.com/EI-ASPM/SCLCM-V7/>

Source: Scholarly Communication Process Model: Authors' analysis.

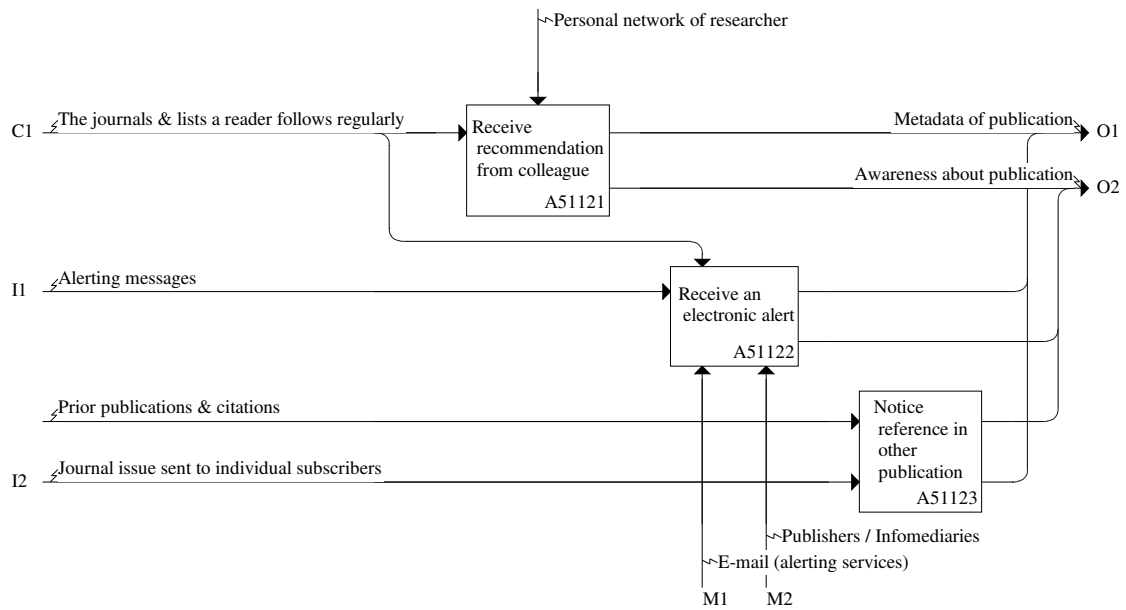
**A5112: Being alerted to publications** depends on receiving recommendations from colleagues, receiving electronic alerts or noticing references in other publications (Figure A5112). Constrained by the researchers personal network, these depend on publishers and infomediaries, and electronic alerting services.

**A513: Retrieving the publication** is constrained by access, with access to toll published material dependent on the availability of funding for access to publications (*e.g.* library acquisitions, project or personal funding) and mediated by the decision to by (Activity A512, above). Retrieval is different for print and electronic versions (Figure A513).

- *Retrieving a print publication* depends on access through libraries or inter-library loan facilities, physical or online booksellers, and is constrained by ergonomic and time considerations; while
- *Retrieving an electronic publication* depends on access through toll access publisher or hosting IT systems and platforms, or OA repositories, library and online delivery systems, and the Internet.

Both are constrained by having access to the publication(s).

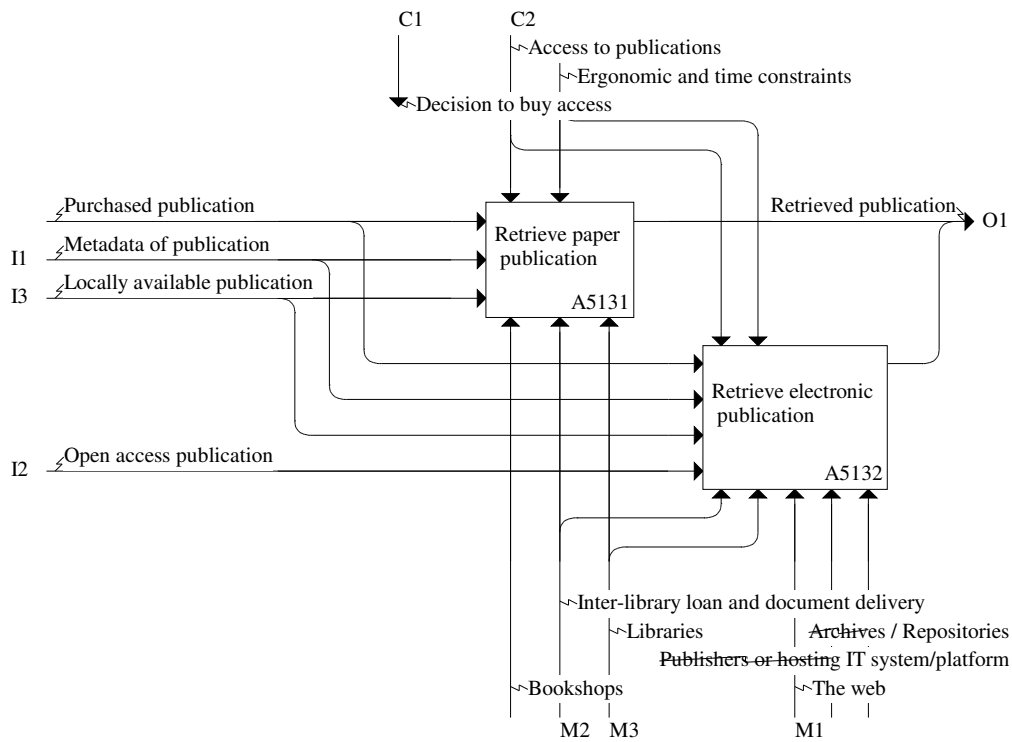
Figure A5112: Be alerted to publications



Link: <http://www.cfses.com/EI-ASPM/SCLCM-V7/>

Source: Scholarly Communication Process Model: Authors' analysis.

Figure A513: Retrieve publication

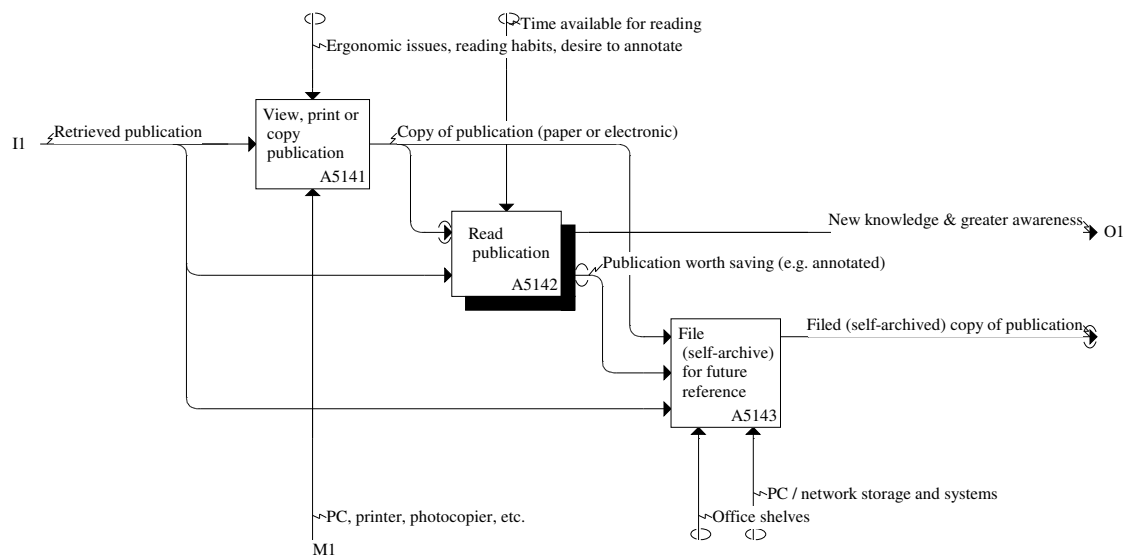


Link: <http://www.cfses.com/EI-ASPM/SCLCM-V7/>

Source: Scholarly Communication Process Model: Authors' analysis.

**A514: Reading and processing publications** follows retrieval and involves viewing, printing or copying the publication, reading it and filing it for future reference (Figure A514). Viewing and printing depends on the availability of equipment such as personal computers, printers and copiers, the time available for reading, ergonomic issues, reading habits and the extent to which annotation is necessary, and filing for future reference will depend on the publication's importance to the reader.

Figure A514: Read and process publication



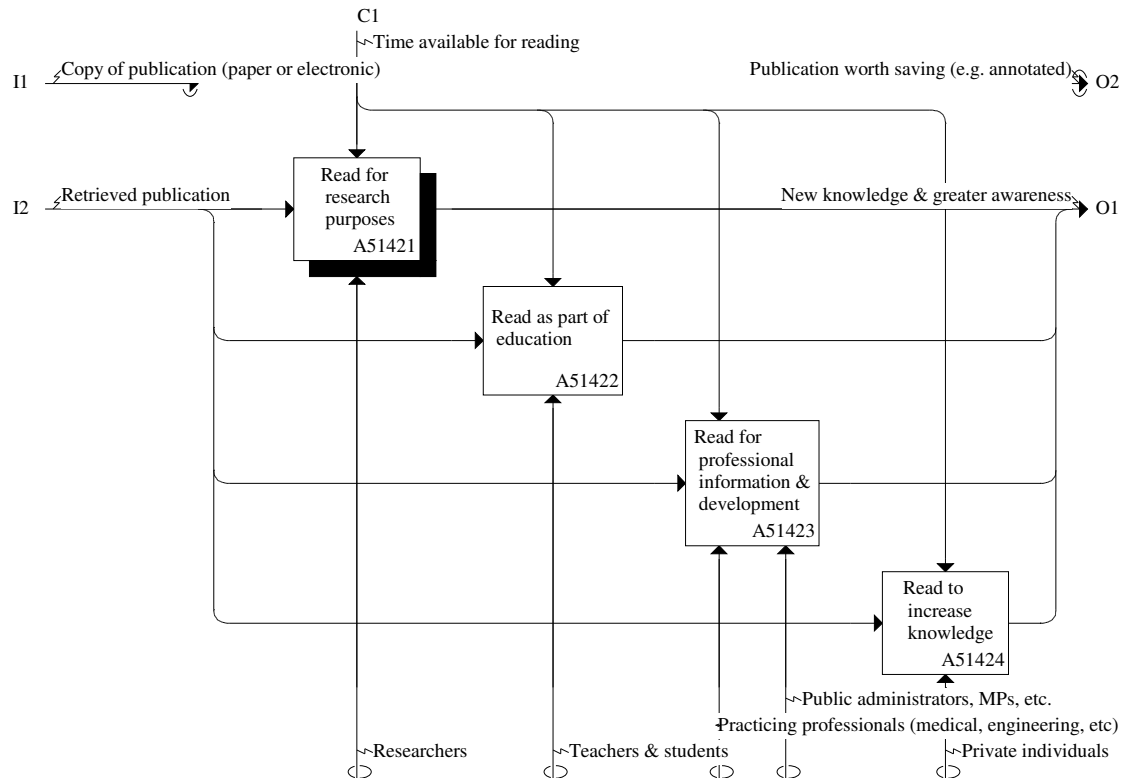
Link: <http://www.cfses.com/EI-ASPM/SCLCM-V7/>

Source: Scholarly Communication Process Model: Authors' analysis.

**A5142: Reading publications** can be classified by purpose, including reading for research purposes, reading as a part of education, reading for professional information and development, and reading for curiosity and interest simply to increase knowledge (Figure A5142). All are constrained by the time available for reading and produce new knowledge and/or greater awareness, but each involves a different group of readers: researchers, teachers and students, practicing professionals and public administrators, and private individuals, respectively (each with different priorities, facilities and costs).



Figure A5142: Read publication



Link: <http://www.cfses.com/EI-ASPM/SCLCM-V7/>

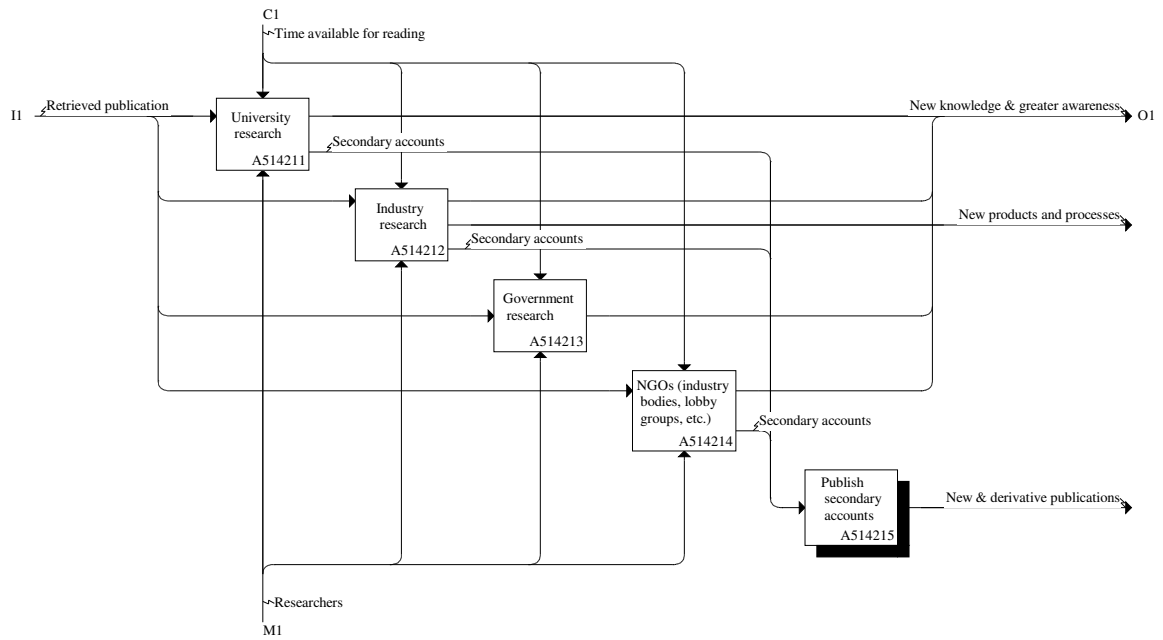
Source: Scholarly Communication Process Model: Authors' analysis.

**A51421: Reading for research purposes** differs with the setting of the research (Figure A51421). All involve researchers and result in new knowledge and greater awareness. University research tends to produce further research publications and data, while industry research may lead to new products and processes, and other research settings encourage researchers to produce secondary accounts – further communicating the findings of research.

**A514215: Publishing secondary accounts** can involve reporting on lists and blogs, reporting in review articles, incorporating material into textbooks and teaching materials, or reporting in the popular media (Figure A514215). This can involve researchers and professionals, and in the latter case may also involve journalists and commentators, and result in the production of research contributions to interest group discussions, review articles, textbooks and teaching materials, and media reports.<sup>41</sup>

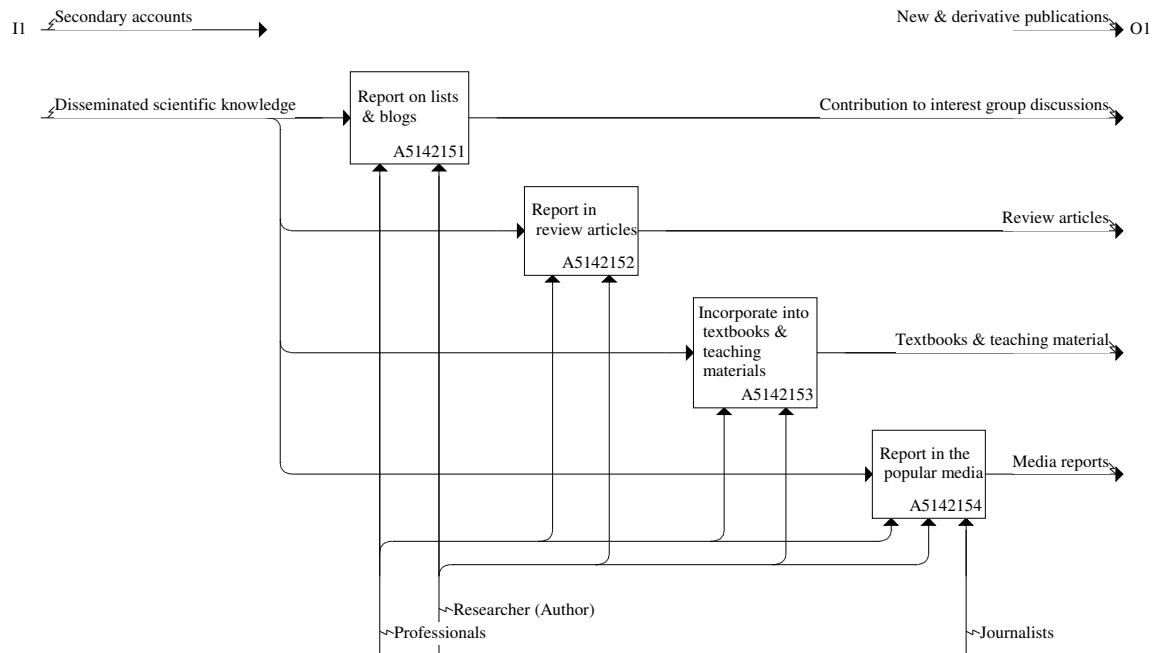
<sup>41</sup> A number of authors have noted the importance of media coverage in communicating research (see, for example, Phillips *et al* 1991; Kiernan 2003).

Figure A51421: Read for research purposes



Link: <http://www.cfes.com/EI-ASPM/SCLCM-V7/>  
 Source: Scholarly Communication Process Model: Authors' analysis.

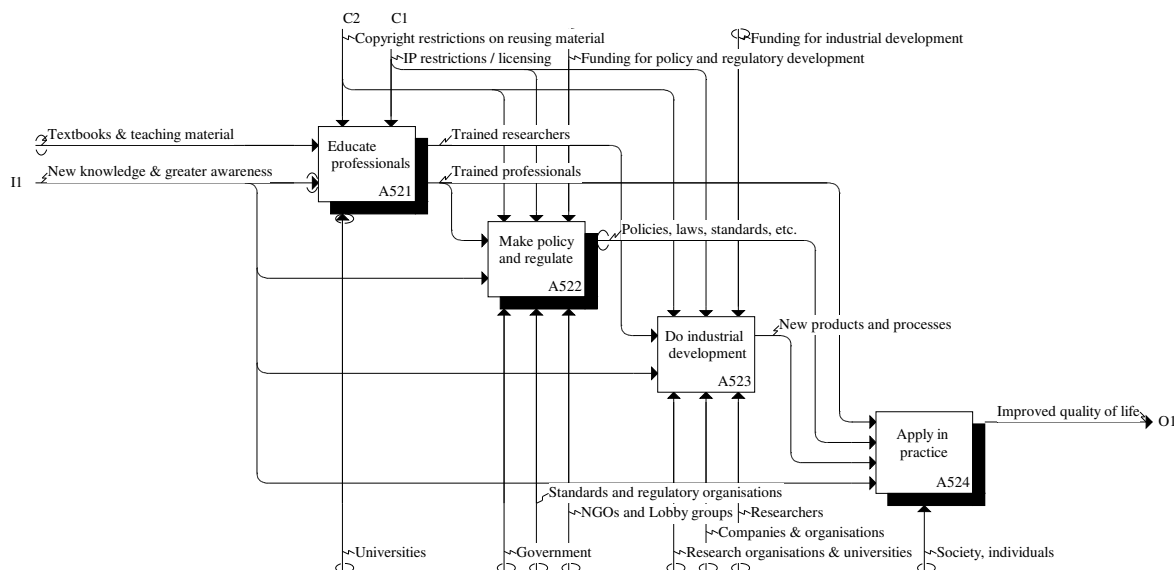
Figure A514215: Publish secondary accounts



Link: <http://www.cfes.com/EI-ASPM/SCLCM-V7/>  
 Source: Scholarly Communication Process Model: Authors' analysis.

**A52: Applying the knowledge** involves educating professionals, making policy and regulating, and applying to industrial development and in practice (e.g. medical practice) (Figure A52). There are many actors and constraints involved.

Figure A52: Apply the knowledge



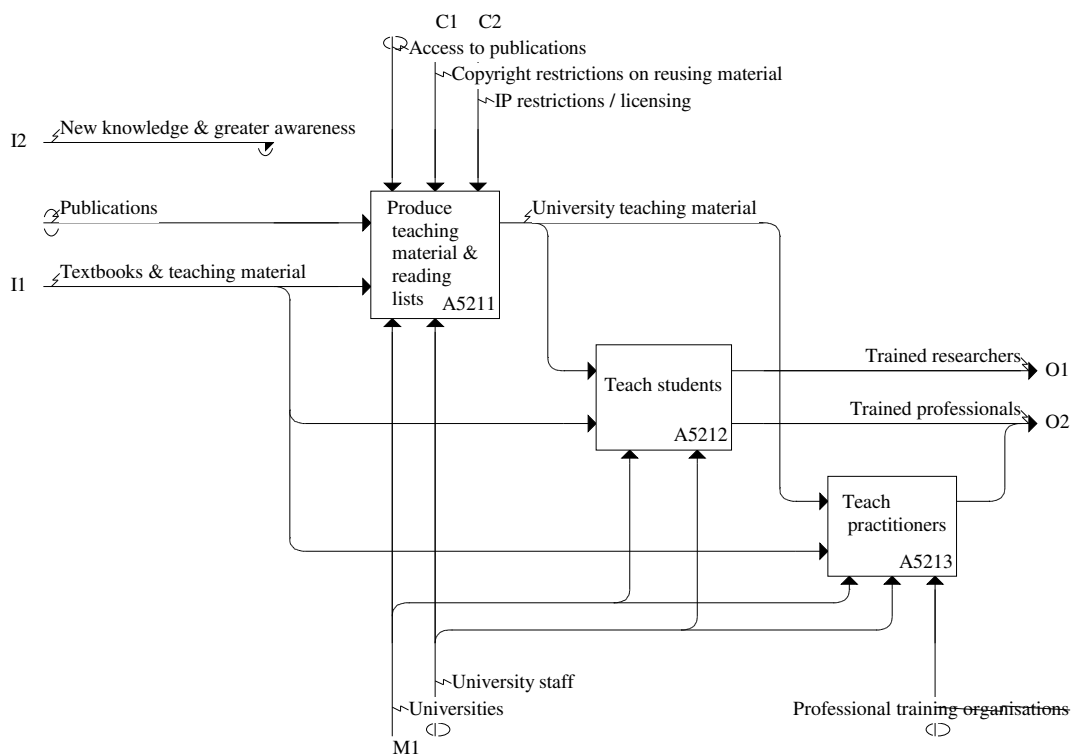
Link: <http://www.cfses.com/EI-ASPM/SCLCM-V7/>

Source: Scholarly Communication Process Model: Authors' analysis.

**A521: Educating professionals** involves producing teaching materials and reading lists, teaching students and practitioners (Figure A521). This involves universities and public and private sector professional training organisations, and activities are constrained by access to publications, IP restrictions and licensing – such as copyright costs and restrictions on reusing materials in course-packs.

**A522: Making policy and regulating** involves such activities as defining public policy and legislating, defining and publishing standards, and granting patents; with actors including, government departments and agencies, NGOs, lobby and interest groups, standards and regulatory organisations, and patent authorities (Figure A522). Activities are constrained by IP and licensing restrictions, copyright restrictions on reuse, and standardisation practices; and are limited by the funding available for policy and regulatory development.

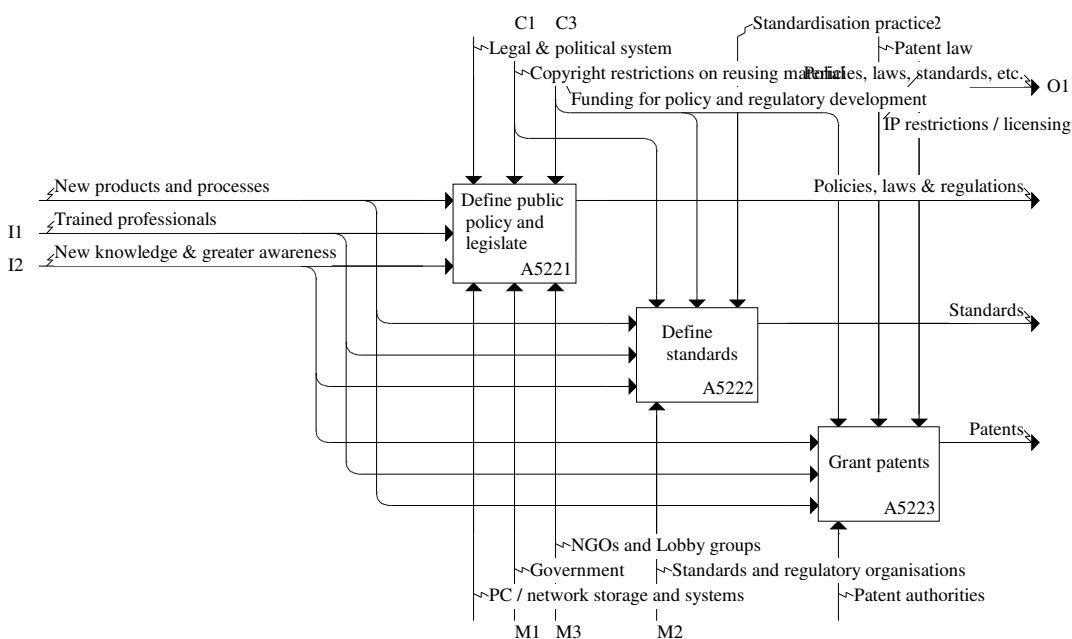
Figure A521: Educating professionals



Link: <http://www.cfses.com/EI-ASPM/SCLCM-V7/>

Source: Scholarly Communication Process Model: Authors' analysis.

Figure A522: Make policy and regulate

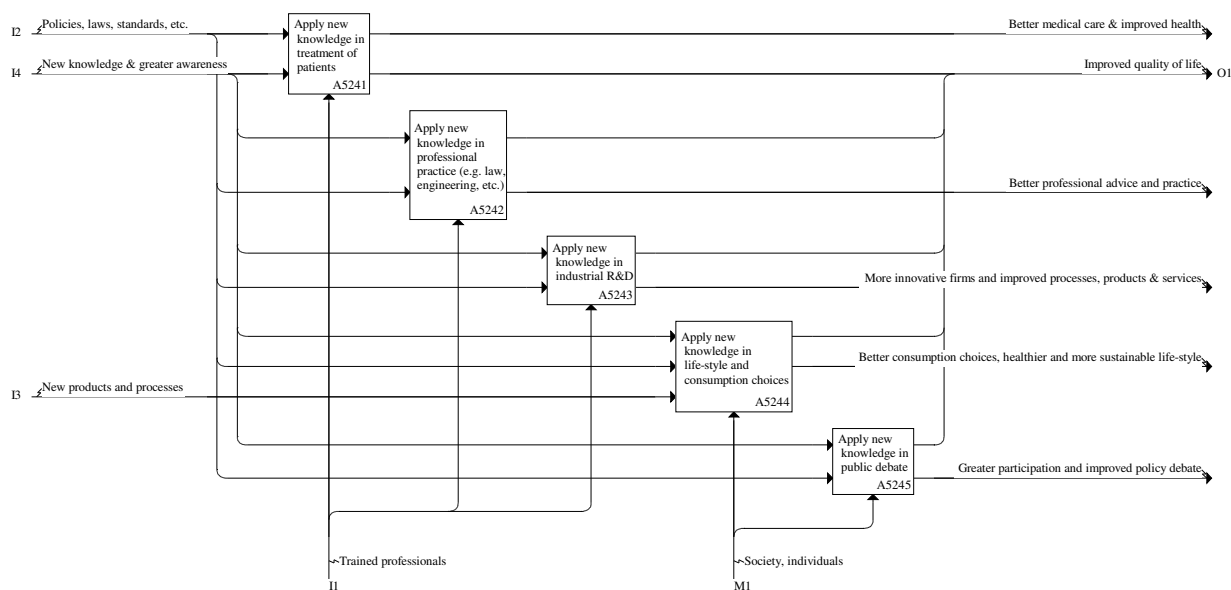


Link: <http://www.cfses.com/EI-ASPM/SCLCM-V7/>

Source: Scholarly Communication Process Model: Authors' analysis.

**A524: Applying in practice** involves such things as applying new knowledge in the treatment of medical patients, in professional practice in such areas as law and engineering, in industrial research and development activities, in public and policy debate, and in lifestyle and consumption choices (Figure A524).

Figure A524: Apply in practice



Link: <http://www.cfses.com/EI-ASPM/SCLCM-V7/>

Source: Scholarly Communication Process Model: Authors' analysis.

### 2.5.2 Identification of the costs involved in studying publications and applying knowledge

The analysis of costs relating to studying and applying knowledge is surprisingly limited, with the Tenopir and King surveys of US-based researchers' activities noted above being the principal source. Some of the Tenopir surveys of the activities of university-based 'users' have extended to other countries (*e.g.* Australia).

As noted, Tenopir and King (2000, p135) found a range of reading activity across university-based and non-university scientists in the US, with university scientists each reading an average of 188 scholarly journal articles, 48 books and 134 other items per year. By 2003, university scientists' reading had increased to an average of 216 articles per year (Tenopir 2005). And as Tenopir and King (2002) noted, the number of articles read and time spent reading varies significantly between research fields. In 2000-01, the medical faculty surveyed read an average 322 articles per year compared to 72 for engineers (111 by 2003), and spent 118 hours per year reading compared with 72 hours (an average of 22 minutes, compared with 76

minutes). Overall, the average time spent reading articles across the research fields surveyed was approximately 52 minutes per article.

Reviews of the literature on the costs associated with studying and applying knowledge, and identification of those costs, have been presented in:

- Halliday, L. and Oppenheim, C. (1999) *Economic Models of the Digital Library*, eLib, United Kingdom Office of Library and Information Networking.
- Tenopir, C. and King, D.W. (2000) *Towards electronic journals: realities for scientists, librarians and publishers*, SLA Publishing, Washington DC. and elsewhere.
- EPS, *et al.* (2006) *UK scholarly journals: 2006 baseline report – An evidence-based analysis of data concerning scholarly journal publishing*, Research Information Network, Research Councils UK and Department of Trade and Industry.
- Houghton, J.W. Steele, C. and Sheehan, P.J. (2006) *Research Communication Costs in Australia, Emerging Opportunities and Benefits*, Department of Education, Science and Training, Canberra.
- Björk, B-C. (2007) ‘A model of scientific communication as a global distributed information system,’ *Information Research* 12(2) paper 307.

Between 1984 and 2000, the average time spent browsing or searching for each article doubled. The time spent obtaining or accessing the article was about the same in the two surveys, but when the time involved in other activities, such as locating, displaying, and downloading or printing was added, the time spent totalled 17.7 minutes per electronic/digital reading in 2000, compared with 8.2 minutes for browsing print copies (including locating and photocopying the articles). This rather curious finding may reflect such factors as the increasing volume of literature, lack of established practices or, perhaps, increasing access difficulties.

Exploring performance issues, Halliday and Oppenheim (1999, p53) noted a number of ‘costs’, suggesting that:

- Users are reluctant to use a new system unless there are clear benefits;
- Time taken to download is important;
- Users prefer not to have to login at all, and complicated login procedures invariably deter use;
- A single, common interface is an important feature; and
- Users expect seamless discovery and access (including following links without barriers).

Thus, pointing to the costs associated with different proprietary access systems and interfaces, authentication and toll barriers, etc. Jubb *et al.* (2007) noted the frustration expressed by researchers over problems gaining access to the sources and materials they identified by searching, saying that their most frequently expressed difficulty was their inability to gain access to journal articles because of a subscription barrier. An issue noted by many (e.g. Swan

2008b). Meaningful (*i.e.* identifying) filenames are also important, with some publisher systems still offering .pdf files with unhelpful default filenames like ‘sdarticle.pdf’ (Science Direct), which adds to the burden imposed on readers when filing for future use. Nilsen (2007) noted that “Opportunity costs apply equally to consumers, and the imposition of these costs (*e.g.* in dollars and time) on information users can reduce the social net benefit of an information product or services.”

**Table 2.8: Study and apply knowledge: major cost items**

| <i>Activity/Item</i>                                | <i>Description</i>   |
|---|--|
| <b>Study:</b>                                       |  |
| Search and discovery                                | Time and local facilities and equipment for search and discovery.  |
| Alerting services/mechanisms                        | Time and local systems to support alerting messages.   |
| Retrieval (Toll Access)                             |  |
| <i>Print</i>  | <i>Time to access and retrieve print materials, acquisition and transaction costs, handling costs, etc.</i>  |
| <i>Electronic</i>                                   | <i>Time to access and retrieve online materials, acquisition and transaction costs, handling costs, etc.</i>   |
| Retrieval (Open Access)                             | Time to access and retrieve OA content, and handling costs.  |
| View, print, copy and file for reference and re-use |  |
| <i>Toll Access</i>                                  | <i>Time/ease and local equipment and facilities to view, print, copy and file material as needed, checking rights and permissions, etc. (Toll access IP and licensing restriction may prevent users copying, filing and re-using).</i> |
| <i>Open Access</i>                                  | <i>Time/ease and local equipment and facilities to view, print, copy and file material as needed.</i>  |
| Purpose specific reading                            | Time spent reading for research, education, professional information and development, and to increase knowledge generally.   |
| <b>Apply:</b>                                       |  |
| Purpose specific applications                       |  |
| Research  | Time/ease of application to research ( <i>e.g.</i> permissions and use/re-use restrictions).   |
| Education   | Time/ease of application to education ( <i>e.g.</i> permissions and use/re-use restrictions).  |
| Profession information                              | Time/ease of application to professions ( <i>e.g.</i> permissions and use restrictions, trust and quality control, etc.).  |
| Increase knowledge                                  | Time/ease of application to personal research ( <i>e.g.</i> trust and quality control, etc.).  |
| Secondary accounts                                  | Time and ease of producing secondary accounts ( <i>e.g.</i> permissions and use/re-use restrictions).  |

Source: Authors’ analysis.

Table 2.8 presents a summary of the major cost items identified, based on the process model outlined above and a review of the literature.

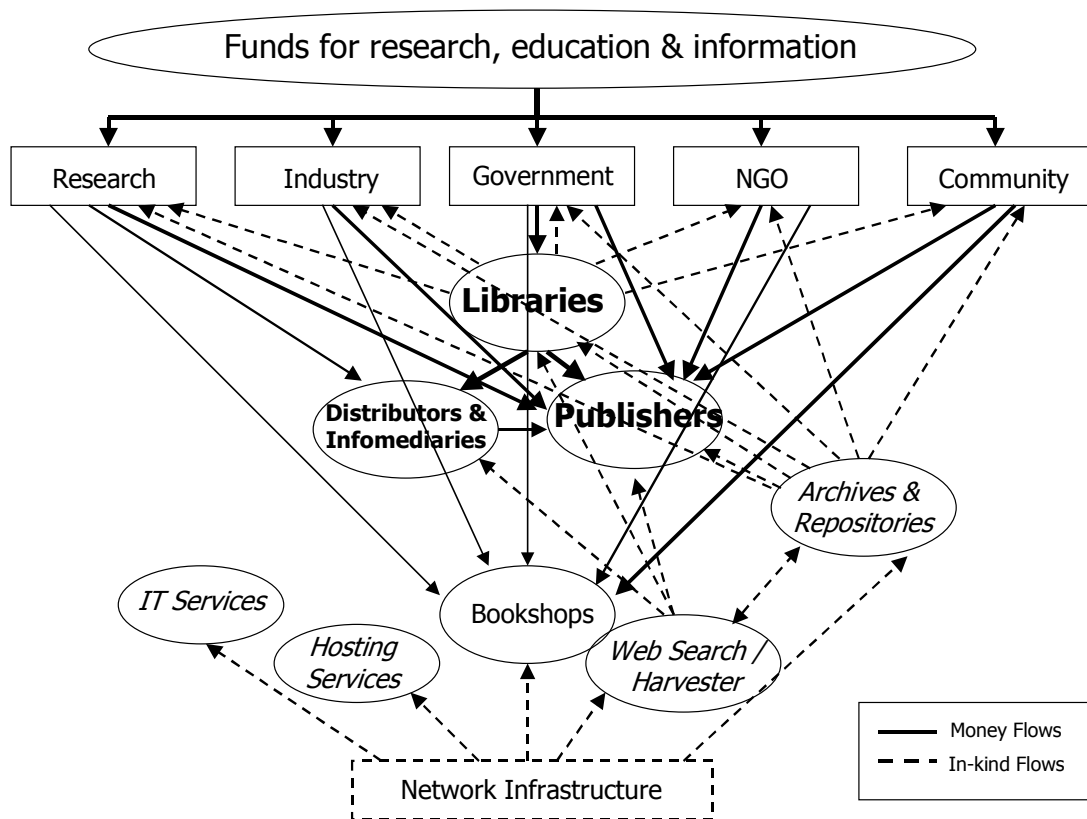
- *In study* – the major costs relate to users’ time spent in search and discovery, retrieval, printing, copying, filing and reading, and the local facilities, equipment and systems that support these activities; while

- *In application* – costs relate to the time and ease of application for the users’ specific purposes: be it in further research, education, professional development and application, or general awareness and knowledge development. Accessibility and usability in terms of permissions and formats are central.

### 2.5.3 Funding flows relating to study and application

Studying and applying knowledge depends on the funding and support available for the activity, be it in the form of research funding or direct or indirect support for the range of professional and social activities. At the moment, the primary flow of funds is from users (*i.e.* the readers and appliers of scientific and scholarly research results) to content and content related access services and systems suppliers (*e.g.* for subscriptions or pay-per-view, alerting and document delivery services, local equipment and systems suppliers, etc.). By making access free to the user, OA changes these flows substantially.

Figure 2.7: Simplified funding flows relating to studying and applying



Study & Apply

JISC EI-ASPM 2008

Source: Authors’ analysis.



### *2.5.4 The impacts of alternative publishing models on studying and application activities*

As noted, the main areas of cost impact of alternative publishing models relate to accessibility and usability – content costs, search, discovery and retrieval time, and permissions to use and re-use as required. These include:

- The elimination of direct toll access costs for users through OA publishing and/or self-archiving.
- Reduced costs and new opportunities to use and re-use materials in OA (*e.g.* use for new forms of research, use for education, etc.).
- Possible cost impacts on search and discovery (*e.g.* proprietary access systems used to control toll access involving use of multiple interfaces and imposing learning and switching costs on users, etc.). Halliday and Oppenheim (1999, p17) reported that the variety of systems proved frustrating to users.
- Possible differences in the timeliness of retrieval (*e.g.* delays caused by authentication slowing download, payment barriers and transaction time, document delivery, etc.).
- Potential for OA to reduce or eliminate the delays, costs and frustration caused by access barriers when trying to follow hyperlinks.
- Reduction or elimination of document delivery and ILL costs with OA.
- Self-archiving allows user choice – immediate free access to the pre- or post-print versus access to the value-added version in a journal (Green OA).
- Possible differences in the availability and usefulness of altering services (*e.g.* difficulty of replicating the thematic bundling of material achieved by journals directly from OA institutional repositories, although subject repositories can provide thematic alerting).
- Toll versus open access differences and clarity regarding permissions to use and re-use material for the users' purposes.
- Copyright clearing agency payments could be reduced/eliminated under OA (*e.g.* elimination of per page clearing agency charges for copies of course-packs).

## 3 Identifying potential benefits

It is always more difficult to identify and quantify benefits than costs. Benefits may accrue in a variety of ways, including cost savings, efficiency gains, and new opportunities to create value through doing things in new ways and doing new things. These are, successively, more difficult to quantify: not least because they often emerge over time and can only be realised in the future (e.g. Kingma 2001; Nilsen 2007). This section focuses on the *identification* of the potential benefits of alternative scholarly publishing models. The *quantification* of those benefits is the topic of Part II of this report.

### 3.1 Dimensions of impact and benefit

There are various ways to explore the impacts and possible benefits of different scholarly publishing models. Focusing on access and use, Houghton *et al.* (2006) noted that potential benefits include impacts relating to research use, industry and government use, and use by the wider community. They suggested that the most immediate impacts would be felt within research, wherein potential benefits include:

- Speed of access, speeding up the research and discovery process, reducing the time and cost involved in achieving a given outcome and improving the efficiency of R&D;
- More complete access, leading to better informed research, reducing the pursuit of blind alleys and duplicative research, saving wasteful R&D expenditure and improving the efficiency of R&D;
- Wider access, providing enhanced opportunities for multi-disciplinary research, inter-institutional and inter-sectoral collaborations, and enabling researchers to study their context more broadly, potentially leading to increased opportunities for application and commercialisation; and
- Greater public access, leading to improved research education outcomes, enabling a given education spend to produce a higher level of educational attainment, leading to an improvement in the quality of the ‘stock’ of researchers and research users.

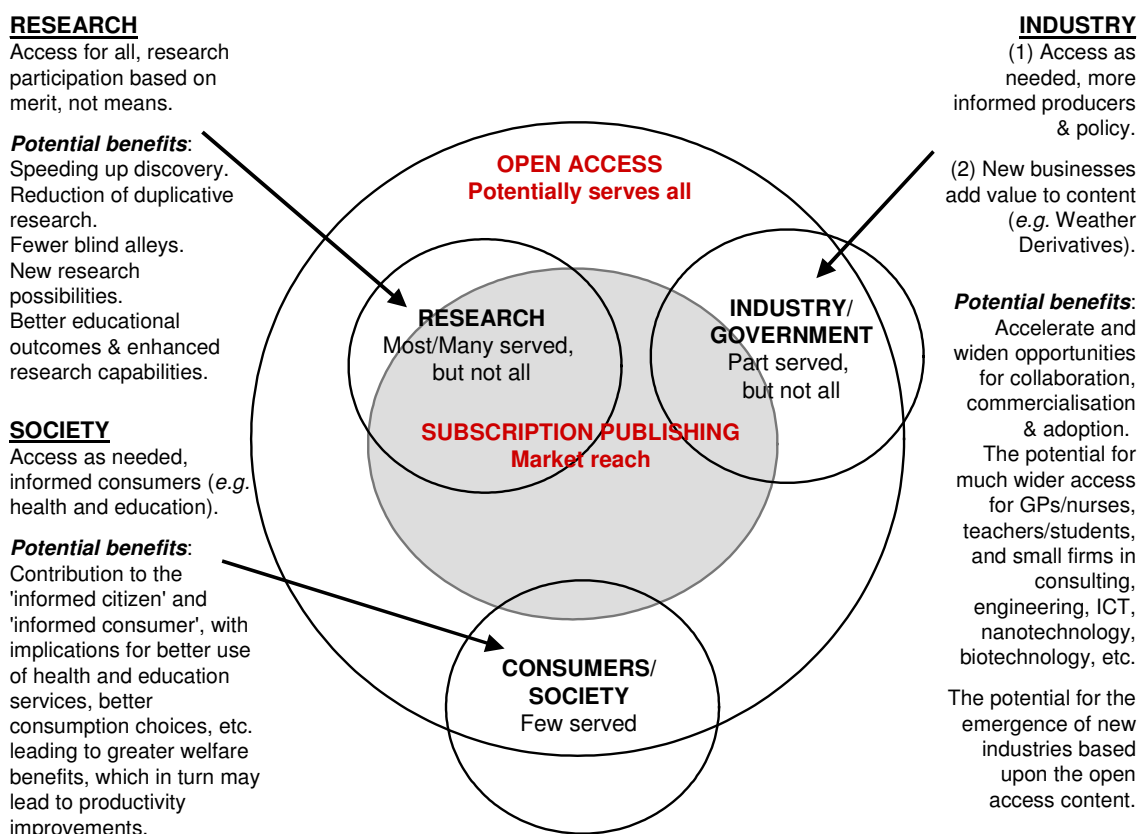
Given relative levels of access under the subscription publishing system, Houghton *et al.* (2006) suggested that the impacts of enhanced access for industry and government users may also be significant, with potential benefits including:

- The potential for wider access to both accelerate and widen opportunities for adoption and commercialisation of research findings, thereby increasing returns on (public) investment in R&D and reducing the cost of (private) investment in its commercialisation;
- The potential for wider access for doctors and nurses, teachers and students, smaller firms in knowledge-intensive industries, such as consulting, engineering, architecture and design, electronics, software, biotechnology, nanotechnology, etc., with a positive

impact on quality of service, innovation and productivity in those sectors of the economy; and

- The potential for the emergence of new industries based on readily accessible content (as happened with the Weather Derivatives industry based on meteorological data), with potential for the emergence of value adding services overlaying the content (e.g. peer review services, bibliometrics and webometrics for research evaluation, etc.).

Figure 3.1: An impacts framework: subscription publishing versus open access



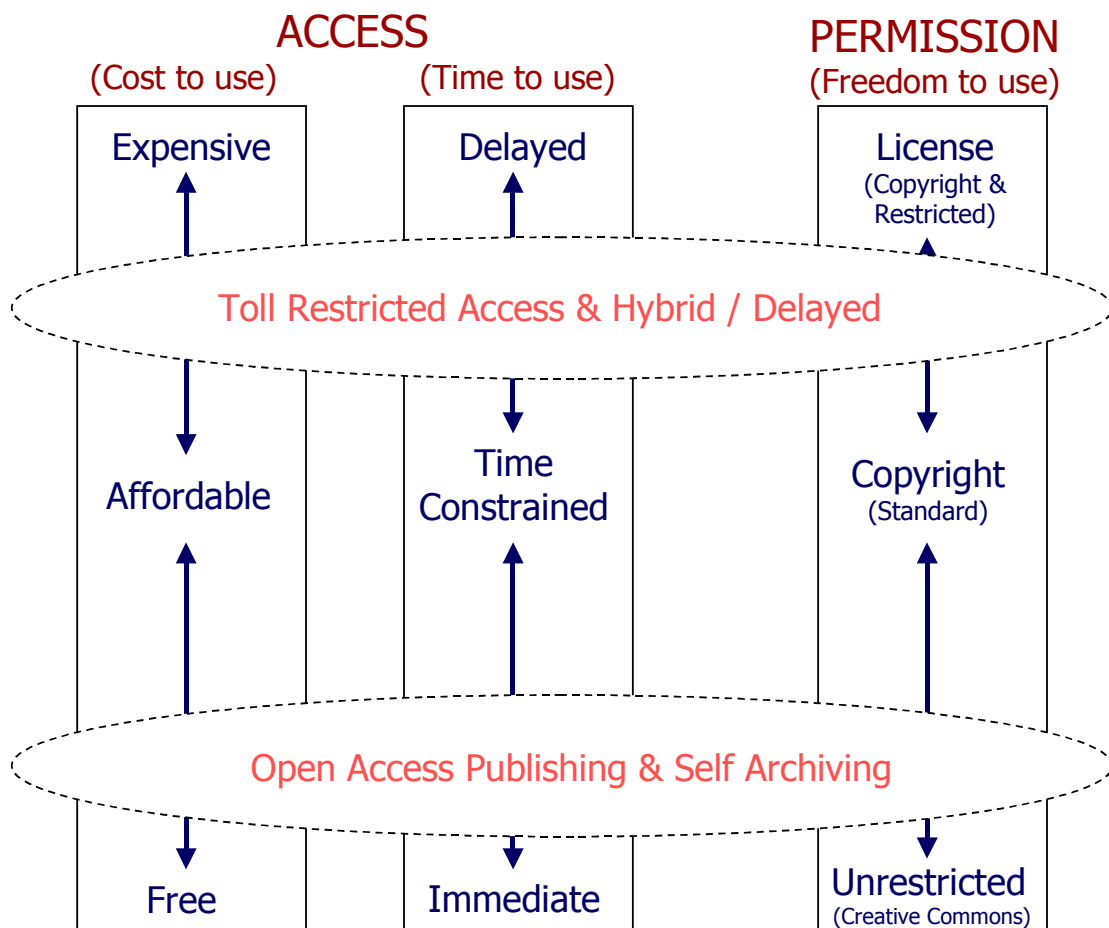
Source: Derived from Houghton, J.W., Steele, C. and Sheehan, P. (2006) *Research Communication Costs in Australia, Emerging Opportunities and Benefits*, Department of Education, Science and Training, Canberra, p34.

They suggested that impacts might be felt more in particular industries (e.g. knowledge intensive services, biotechnology, etc.). Impacts in such areas as management and economic consulting and engineering might be particularly significant, raising the quality of advice to the benefit of clients across the economy. There may also be significant impacts on policy development, through more informed policy debate and enhanced access to the 'science' underpinning policy decisions. One particularly important dimension might be the potential for greater access for small firms, enabling them to do more research internally, thereby increasing their 'absorbive capacity' and enabling them to be more innovative.

In relation to the wider community, Houghton *et al.* (2006) suggested that benefits might include the potential contribution of enhanced access to the ‘informed citizen’ and ‘informed consumer’, with implications for better use of health and education services, and better consumption choices leading to greater welfare benefits.

While providing a useful starting point, the analysis focused on economic impacts and did not explore the production-side impacts fully or explicitly. The key issues in OA are access and permission – where *access* includes accessibility in the sense of ease and affordability (time and cost), and *permission* refers to permission to use the material in terms of what is permitted and the time and cost involved in obtaining permission. This suggests analysis along the overlapping dimensions of access and permission, mediated by cost in terms of both money and time. In essence, the time and cost involved in accessing and using scientific and scholarly works however and whenever required for whatever purpose (*i.e.* free, immediate and unrestricted) (Figure 3.2).

Figure 3.2: Dimensions of impact and benefit: access and permission



Source: Authors’ analysis.

Drawing on a number of previous reviews and following an established lead, Martin and Tang (2007) explored seven mechanism or channels through which the benefits of publicly funded research may flow through to the economy or to society more generally, namely:

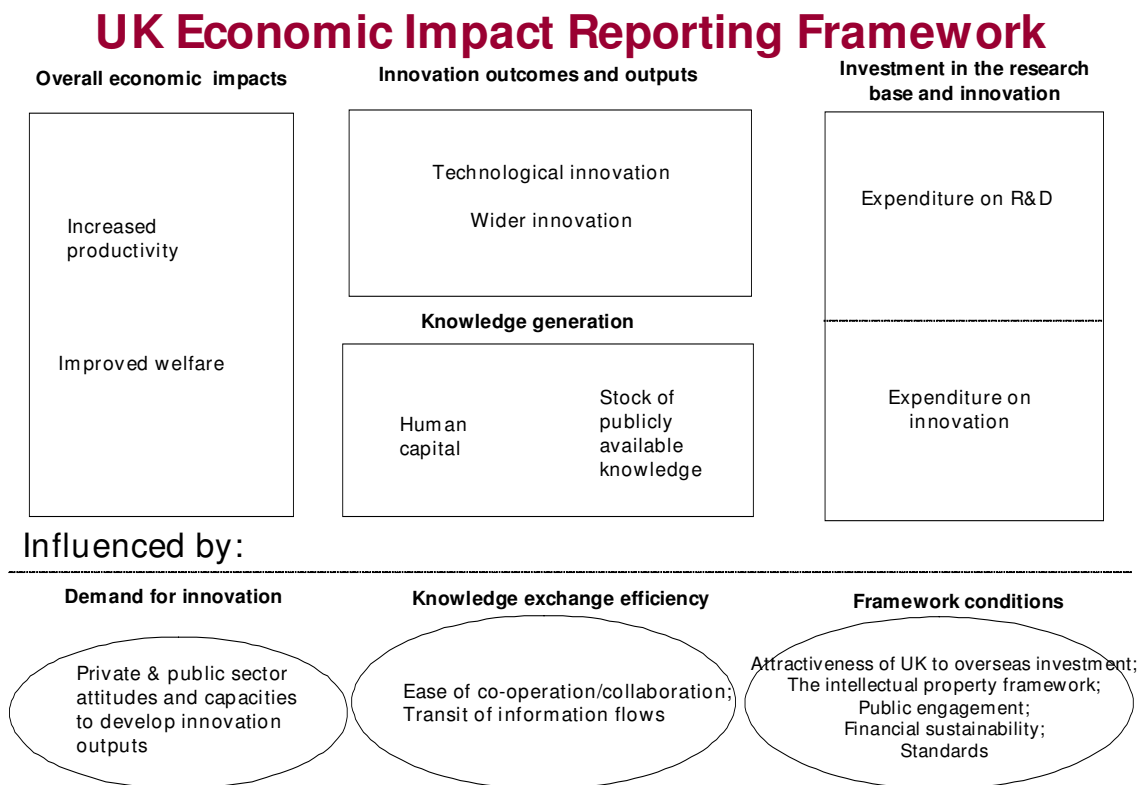
1. An increase in the stock of useful knowledge;
2. The supply of skilled graduates and researchers;
3. The creation of new scientific instrumentation and methodologies;
4. The development of networks and stimulation of social interaction;
5. The enhancement of problem solving capacity;
6. The creation of new firms; and
7. The provision of social knowledge.

Enhanced access and reduced permissions barriers are important in all of these (arguably, with the exception of number 3). More open and less restricted access would effectively increase the stock of useful knowledge that is accessible to would-be users; contribute through impacts on education to enhancing the supply and skills of researchers; enable the development of networks on the basis of a shared, common and complete set of information; enhance problem solving capacity by providing necessary supporting information; enable the provision of a range of social knowledge (*e.g.* in health care); and provide opportunities for the emergence of new firms and new industries (as noted above).

When the then Department of Trade and Industry outlined an Economic Impact Reporting Framework (DTI 2007), the focus was on the influences of the demand for innovation, knowledge exchange efficiency and framework conditions (Figure 3.3). Each involve elements relating to awareness (*e.g.* public and private sector attitudes and capacities), access (*e.g.* information flows and ease of cooperation and/or collaboration) and permissions (*e.g.* intellectual property framework). Moreover, there have been a number of studies showing the industry impacts of publicly funded science in general, and of scientific and scholarly publications in particular – including the PACE Survey of large European firms, which showed that firms rely heavily on scientific publications as a primary source of information about publicly funded research (Arundel *et al.* 1995).

Of course, the principal input to the process of doing research and communicating the results is existing knowledge (See *Figure A: Scholarly communication process*, above). The production of knowledge depends, in large part, on its consumption. Hence, costs and benefits on the production-side also relate, in large part, to access and permission – the costs associated with limiting and managing access, copyright, licensing and permissions; and the cost savings (‘direct benefits’) of not doing so. Indirect benefits also relate, in large part, to access and permission – the greater use, higher profile and higher impact/return for funders, researchers and research institutions, publishers and those facilitating dissemination, retrieval and preservation. Access and permission, therefore, are crucial to the overall efficiency of the scholarly communication system.

Figure 3.3: UK Economic Impact Reporting Framework



Source: DTI (2007) *Measuring economic impacts of investment in the research base and innovation: a new framework for measurement*, Department of Trade and Industry, London.

Hence, our approach to exploring and quantifying costs, impacts and benefits is twofold. First, a detailed ‘bottom up’ costing which provides a foundation for the estimation of cost savings and for the development of scenarios exploring impacts and benefits – primarily direct benefits. Second, a ‘top down’ modelling of impacts on returns to R&D through, for example, further development and application of the modified Solow-Swan model outlined in Houghton *et al.* (2006), which introduced *accessibility* and *efficiency* into the standard model, as negative variables, in order to explore the impact of increasing accessibility and efficiency on returns to R&D expenditure. Such an approach combines the principal methods that have been used to explore the impacts of R&D (*i.e.* macro econometric studies and case studies).

### 3.2 Impacts and potential benefits identified in the literature

There is an extensive literature on the potential costs, benefits and impacts of more open access, but core themes and arguments recur throughout. Consequently, we have not attempted an exhaustive literature review, but simply present some key points noting one or two of the more prominent references. This is followed by a listing of the potential benefits identified, drawing on the process model outlined above and our review of the literature.

### 3.2.1 Access issues and limitations

There is evidence to suggest that toll access publishing has created access limitations, even for researchers in higher education and specialist research centres in developed countries. For example, in a survey of more than 5,500 senior researchers, Rowlands and Nicholas (2005, p23) found that almost 74% thought that “high prices made it difficult to access the journal literature.” Sparks (2005, pp26-28) reported that almost half of the 750 researchers she surveyed reported having problems gaining access to the resources they needed for their research – with more than half in medical and biological sciences (52.5%) and arts and humanities (53.4%) reporting difficulties. The major problem reported was access to journal articles, books and conference proceedings. Of those reporting difficulties, between 80% and 90% of researchers in medical and biological sciences, physical sciences and social sciences said that their “library did not take the journals they needed to access for their work”, as did 70% to 80% of those in languages, arts and humanities. Looking at discovery services (Jubb *et al.* 2007) noted that “The main frustration expressed by researchers is... with the problem of then gaining access to the sources and materials they have identified... Their most frequently expressed difficulty is their inability to gain access to journal articles because of a subscription barrier.” Such cost and access difficulties are often noted (*e.g.* Swan 2008b).<sup>42</sup>

Outside the richer countries, even outside the richer institutions within developed countries, access difficulties have been more pronounced. A number of authors have noted the particular benefit of open access for developing countries, where access to the subscription-based literature has often been limited. Chan *et al.* (2005, p2) noted that: according to a recent survey conducted by the World Health Organization, in the 75 countries with an annual GNP per capita of less than USD 1,000, some 56% of medical institutions had no subscriptions to journals over the last five years; and in countries with a GNP of USD 1,000 to 3,000, 34% had no subscriptions and a further 34% had an average of two subscriptions per year.

There are many anecdotes to be found. For example, Yamey (2006) noted three such stories.

- The first, a letter published in *The Lancet* 2004 (364) from researchers at Osaka University Medical School who felt compelled to share their experiences in accessing biomedical journals in their home countries of Indonesia and China. They concluded: “It is unquestionable that the user-pays system has harmed communication of research findings to the medical community in these countries, and its consequences for the improvement of medical services is obvious.”
- The second, a personal anecdote told by Arthur Ammann (President, Global Strategies for HIV Prevention), explaining how worried he was that physicians in many parts of the world could usually only see abstracts... saying: “I recently met a physician from Southern Africa, engaged in perinatal HIV prevention, whose primary access to information was abstracts posted on the Internet. Based on a single abstract, they had

---

<sup>42</sup> It is notable that SCONUL libraries reported collective acquisition of almost 1.4 million serials titles in 2006-07, with a mean of reporting institutions of 8,391 and a median of 5,864. It is widely reported that there are around 23,750 peer reviewed journals being published. Not all serials are journals and not all journals are subscription access, but even if they were, and ignoring duplicate subscriptions, SCONUL libraries appear to be subscribing to no more than around 25% to 35% of journals.



altered their perinatal HIV prevention program from an effective therapy to one with lesser efficacy. Had they read the full text article they would have undoubtedly realized that the study results were based on short-term follow-up, a small pivotal group, incomplete data, and unlikely to be applicable to their country situation. Their decision to alter treatment based solely on the abstract's conclusions may have resulted in increased perinatal HIV transmission.”

- The third, a posting on HIF-NET [Tue, 15 Mar 2005] saying: “The link she gave us takes one to a sign-on page, and only the extract from the article is available for free – one has to pay to download the pdf or must have a subscription to read the article online. So I will have to forgo the pleasure of reading the article she suggests. Even as an international NGO, we don't have enough money in our budget to take subscriptions to all the interesting journals we might wish for, and this is so much more of a problem in low resource settings with insufficient access to international currency.”

Conversely, access statistics from OA repositories suggest that researchers from developing countries do use them. For example, during 2007 the ARROW Discovery Service (Australian Research Repositories Online to the World) received hits from some 123 top level domains (*i.e.* ccTLDs and gTLDs), including, at the lower end of the scale: 1 from the Cook Islands, 2 from Micronesia and Benin, 4 from Tuvalu, 16 from Zimbabwe, Oman, Cambodia, Uganda and Bangladesh, 17 from the Faeroe Islands, East Timor, Georgia and the Virgin Islands, 19 from Brunei Darussalam, 20 from Kazakhstan, 21 from Zambia, 22 from Jordan, Uzbekistan and Qatar, 23 from Namibia, 67 from Papua New Guinea, and so on.<sup>43</sup> A similarly broad range of access is revealed in other repository statistics.

As important as access to scientific and technical literature is for well-being and development in developing countries, it is not just a one way street. Researchers in developing countries have much to contribute to the development of knowledge (*e.g.* it is known that genetic factors influence and reduce the effectiveness of western treatments for diabetes and tuberculosis in India and China) (Chan *et al.* 2005). But ‘Western’ science dominates the published literature.

### 3.2.2 Access, downloads and citation

There is an extensive literature on the relative citation rates of toll access and open access articles (and journals), and a number of studies have shown that open access articles are used more, both in terms of citations and downloads (*e.g.* Stevens-Rayburn 2003; Antelman 2004; Harnad and Brody 2004; etc.).<sup>44</sup> Others have questioned the results of such studies (*e.g.* Davis 2006; Graig *et al.* 2007), suggesting that there are a number of methodological issues relating to causality and possible intervening variables – including: the age of journal titles, the window of citation period being compared, and other possible explanations for the findings (*e.g.* simple visibility – with papers of which multiple copies are available cited more; selection bias – with more prominent authors more likely to be OA and/or authors more likely to make their best papers available OA; time bias – with OA articles available before publication having more

---

<sup>43</sup> See <http://www.arrow.edu.au/>

<sup>44</sup> See also The Open Citation Project at <http://opcit.eprints.org/oacitation-biblio.html>



opportunity to be cited; etc.).<sup>45</sup> Nevertheless, it is generally accepted that OA articles are cited more (EPS *et al.* 2006; Davis 2006; 2007; Graig *et al.* 2007), with the debate now primarily about how much more and why.<sup>46</sup>

### Box 3.1: The Open Access Advantage

Harnad (2005) noted that the ‘open access advantage’ arises from at least six component factors, of which three are permanent and three temporary. Expressing the open access advantage as “OA advantage = EA + AA + QB + OA + UA” Harnad explained:

EA: EARLY ADVANTAGE, beginning already at the pre-refereeing preprint stage. Research that is reported earlier can begin being used and built on earlier. The result turns out to be not just that it gets its quota of citations sooner, but that quota actually goes up, permanently. This is probably because earlier uptake has a greater cumulative effect on the research cycle. (A permanent effect).

(AA): ARXIV ADVANTAGE, the special advantage of self-archiving specifically in ArXiv for physicists, because it is a central point of call: OAI-interoperable Institutional Repositories [are] likely – for many reasons – to supersede this, so it will eventually make zero difference which OAI-compliant IR one deposits in, as access will be through OAI cross-archive harvesters, not directly through individual OAI Archives.

(QB): QUALITY BIAS, arising from article/author self-selection; this does not play a causal role in increasing impact: the higher-quality (hence also higher-impact) articles/authors are somewhat more likely to be self-archived/self-archivers in these early (15%) days of self-archiving: this bias will of course vanish as self-archiving approaches 100%.

QA: QUALITY ADVANTAGE, allowing the high-quality articles to compete on a level playing field, freed of current handicaps and biases arising from access affordability differences. (A permanent effect).

(CA): COMPETITIVE ADVANTAGE, for self-archived papers over non-self-archived ones, in early (15%) days; this too will of course disappear once self-archiving nears 100%, but at this moment it is in fact a powerful extra incentive, for the low % self-archiving fields, institutions and individuals.

UA: USAGE ADVANTAGE: OA articles are downloaded and read three times as much. (A permanent effect). (There is also a sizeable correlation between early download counts and later citation counts.).

Source: Harnad, S. (2005) OA Impact Advantage = EA + (AA) + (QB) + QA + (CA) + UA. Available <http://eprints.ecs.soton.ac.uk/12085/>.

<sup>45</sup> What is a sustainable OA advantage and what of the initial advantage is not permanent is an important issue in the debate about downloads and citations (See Box 3.1).

<sup>46</sup> The fact of the advantage is important in itself, as the alternative explanations for it depend on enhanced accessibility (however it is achieved). For example, Davis (2006) suggested that simple article duplication increased visibility and citations (saying “OA as article duplication can explain Antelman’s findings”). In this study we seek to compare publishing models which depend, on the one hand on erecting an access barrier and preventing copying in order to maintain that barrier, and on the other hand on free and immediate access with minimal restriction on copying and re-use. The issues central to this study are accessibility and useability (however they are achieved), with the publishing models compared on their ability to achieve the outcomes of enhanced accessibility and useability.

Moreover, it is generally accepted that OA articles are cited more quickly (being available as pre-prints and/or immediately on acceptance) (EPS *et al.* 2006; Schwarz and Kennicutt 2004). Brody and Harnad (2005) provided one example based on arXiv, showing how, as more articles have been deposited over the years, the time between the article being deposited and being cited has been shrinking – suggesting that the research process is speeding up.

### *3.2.3 Access and the wider use of scientific and scholarly works*

Research is conducted and used across all sectors, and the number of authors writing scholarly works is a small sub-set of potential readers in many fields. As readers, academic institutions are reported to account for around one-third to half of global STM publisher revenues, with corporate, government, health and individual customers making up the remainder (EPS *et al.* 2006, p38). Tenopir and King noted that university researchers accounted for only 10-20% of the total US research community in 1995, but accounted for 75% of the journal articles produced; and that only around 15-20% of scientists in the US had authored a refereed article (EPS *et al.* 2006, p30). Hence, even among research scientists, readership (use) is much more widespread than authorship (production).

Looking beyond the research community, Getz (2005, pp11-12) reported a sevenfold increase in use of the MedLine Index following its move to open access, and 30% use by non-professionals – which suggests that there can be significant impact beyond existing subscription users. Similarly, Willinsky (2003) found that policymakers restricted themselves for the most part to open access sources, saying “The interviews with these Canadian policy officials and related personnel make it clear that the Internet is now a favored source of information within government. It is used to tap into the research that is consulted as part of the policy process. It is also clear that the research that is most easily accessible, through portals and open-access sites, is most often consulted, as policymakers referred to how readily they were dissuaded from using pay-per-view and subscription services in their pursuit of knowledge.” There are many such examples (see, for example, the Public Knowledge Project at <http://pkp.sfu.ca/>).

The lack of public access to publicly funded scholarship has been called “the secondary digital divide, which ...affects health organizations in Indonesia, university students in Kenya, and faculty members in Argentina... It reduces the effectiveness of anti-poverty organizations in Vancouver, Aborigine organizations in Sydney, and union organizers in Washington... It limits the education of science fair participants in Wichita and high school history teachers in Charleston. It stymies the curiosity of astronomy club members and amateur oceanographers. Just as a vast, rich world of information is within a click or two of most phone jacks, the toll gates are going up around online scholarly research.” (Willinsky 2003). “The irony of a web without science” was noted by Boyle (2007).

### *3.2.4 Permissions and limitations on use*

The toll access system presents a range of barriers to use (and re-use) through its control of access, copyright and licensing permissions – as the maintenance of the toll barrier requires that copying be prevented.

## Educational use

The contribution of OA publishing and self-archiving to education is potentially significant, both in terms of facilitating easier compilation of teaching and learning materials (*e.g.* course-packs, reading lists and electronic reserve materials for students, learning objects and ‘courseware’), and by simply providing access to the scholarly literature for students outside the larger higher education institutions in smaller universities, colleges and schools and, of course, for their teachers. Such access is particularly useful for the increasingly important areas of part-time and distance education, and life-long learning.

Open Access reduces the time and cost involved in the compilation and provision of e-reserves, in terms of checking and obtaining permissions and copyright payments. Students need not travel to a library or possess proof of affiliation to use OA materials, reducing the costs and time commitments of learners, educators and libraries. And open access to learning objects is an aid to teachers as well as students, circulating innovative approaches and novel materials faster and more effectively than has been possible previously. Moreover, individual teachers can advance their careers when a learning object they create is adopted widely, much as researchers advance when their papers are cited (Salo 2006).

## New research methods

Swan (2007) noted that “Open Access can also advance science by enabling semantic computer technologies to work more effectively on the research record. Such advanced software technologies already exist, awaiting a larger corpus because they need the full text of scientific articles to work on, not just the abstract. Semantic technologies can do two things. First, they hold out the promise of being able to integrate different types of research output – articles, databases and other digital material – to form a single, integrated information resource and to create new, meaningful and useful information from it. An early example of this sort of knowledge creation is the Neurocommons, a project of the ScienceCommons organization. Second, Web 2.0 technologies, the set of tools that aid collaborative effort (including social tagging and filtering and weblogs), can help scientists in their work by offering personalization mechanisms that enable them to tailor and enhance what information they access and share, saving time and effort.” There are many such examples and many calls for access and permission to use and re-use to be found in the literature (*e.g.* Arms and Larsen 2007; Kopak and Chiang 2006; OSI e-Infrastructure Working Group (undated); Terry 2006).

## New services

It has also been suggested that open access to a substantial body of research literature would lead to: “an explosion in services that provided access to this literature in new and creative ways. Such services would also incorporate specialized vocabulary databases, gazetteers, factual databases, ontologies, and other auxiliary tools to enhance indexing and retrieval. They would rapidly transcend access to address navigation and analysis. One path here leads towards more-customized rehosting of scholarly literatures and underlying evidence into new usage and analysis environments attuned to the specific scholarly practices of various disciplines... We would also see a move beyond federation and indexing to actual text mining and analysis, to the

extraction of hypotheses and correlations that would help to drive ongoing scholarly inquiry.” (Lynch 2007).

### 3.2.5 *The conduct and record of science*

Making research more open and transparent helps to prevent misconduct, scientific fraud, etc. by, for example, making data and laboratory or field notes accessible as well as the text of the final paper, and thereby making the stated findings more easily verifiable (*Nature* [Editorial May] 2007). OA may also make it easier to detect plagiarism, with texts and other digital objects more accessible, more usable and searchable, and more easily compared (both directly and automatically) (Suber 2008).

Kircz (2005) noted that the published literature was not, as it is often described, the ‘record of science’ – at least, not the full record. Firstly, because of timing, it is “*the full stop after the fact*” with current discussion in many fields already based on pre-prints and other communications mechanisms (*e.g.* discussion lists, web logs, etc.). Secondly, because of selectivity in publishing, it is “*only a trophy cabinet*” with little reporting in the formal journal literature of failed experiments, and trial and error tests, etc. This latter was also noted by Gallagher (2005, p8), who suggested that OA repositories would be “more likely than existing journals to include accessible archives of negative data.” Similarly, Ampe (2008) noted: “In my view, the recent trend not to publish negative results may affect the progression of science in the long term. I often wonder how many times negative experiments are duplicated by different research groups.” – with obvious efficiency implications.

## 3.3 Identification of impacts and potential benefits

The following sections enumerate some of the potential benefits of enhanced access identified through the process model outlined above and a literature review. We structure our analysis according to the scholarly communication process model, exploring the potential benefits of more open access for those: (i) funding research and communication; (ii) performing research and communicating the results; (iii) publishing scholarly works; (iv) facilitating dissemination, retrieval and preservation; and (v) studying and applying the knowledge.

Self-evidently there are overlaps between costs and benefits, with the benefits of one model and/or for one actor in the system often being costs for others (*e.g.* lost citations, lost impacts and lost opportunities for new research methods could be considered to be among the costs of toll access and/or the benefits of more open access). As a result, there is no single systematic way to describe impacts and enumerate potential benefits, and there is inevitably some repetition.

### 3.3.1 *Fund research and research communication*

Research institutions, funders and managers stand to gain visibility through more open access, with wider awareness and use of research findings and more efficient research reporting, evaluation and management likely to be possible.

**For government and other research funders** the potential benefits of more open over toll restricted access include:

- Increased visibility of national research, which initially might influence the global ranking of domestic universities and may, thereby, attract increased demand and enrolments from both domestic and international students (*e.g.* increased education services exports).
- Increased communication of research findings and issues beyond the research community, with greater access for industry, government and community to those findings contributing to the technology and knowledge diffusion goals of institutions and funders.
- Increased visibility for funders of the research and greater impacts from their funding dollar (*e.g.* increased awareness of the contribution of funders, etc.), which may, in turn, enable them to raise more funding from a wider community and increase overall funding for research.
- Greater support for the operation and management of research reporting and evaluation, by providing the foundation for a single source for reporting information, thereby reducing the cost of grant application and research evaluation reviews.
- Improved metrics, new and more complete metrics (*e.g.* Eigenfactor, h-Index, Journal Influence and Paper Influence Index, Mesur, Usage Factor, Web Impact Factor and Y Factor, as well as improved download statistics (Suber 2007b)), through greater coverage facilitating easier and better quality/more accurate evaluation of the overall contribution, of projects and applications, which may lead to better targeted research spending and enhanced outcomes for a given R&D spend.
- Improved external peer review, through greater ease of access to publications and related material increasing the efficiency and/or quality of peer review (*e.g.* through the ability of reviewers to access material cited in the applications and check them for interpretation, etc. more quickly, easily and thoroughly). This may also lead to better funding decisions, and more efficient and effective allocation of available funding.

**For research institutions and managers** the potential benefits of more open over toll restricted access include:

- Institutional repositories providing a mechanism to showcase the output of institutions and bring it to the attention of a wider audience (*e.g.* institutional repositories contributing to visibility of the institution).
- Increased visibility and citation for the research outputs of institutions, which may lead to more collaboration, industry and community linkages, and more funding opportunities.
- Greater support for the automated analysis of research impacts, citations, etc., with use statistics being broader than academic citations alone and so more useful for, and attuned to, the realities of emerging modes of research (*e.g.* 'Mode 2' research and the 'third path' goals of institutions).

- Reduced cost and improved efficiency in research management and reporting at the individual project, departmental/faculty and institutional levels.
- Greater support for e-learning, with greater opportunity to provide ready and remote access to content, and to provide that content in innovative ways.
- Greater support for education in general, through reducing the cost/time involved in creating course content and providing course related packages (*e.g.* permission to use, reduced time and cost in copyright fees, etc.).

**For all concerned with overseeing research** the potential benefits of more open over toll restricted access include its contribution to:

- Speeding up the research and discovery process, making it more efficient and productive.
- Creating a more complete record of science (*e.g.* enabling the co-location of a range of digital objects, overcoming the tendency of journals to not report negative findings, etc.), thereby improving efficiency by reducing the need for duplicative research and avoiding the pursuit of blind alleys, etc.
- Making research more open and transparent, thereby helping to prevent misconduct and scientific fraud, etc. (*e.g.* making data and laboratory or field notes accessible as well as the text of the final paper, thereby making the stated findings more easily verifiable).
- Helping in the detection of plagiarism, with texts and other digital objects more accessible, more usable and searchable, and more easily compared (Suber 2008).
- Expanding the contribution that scientific and technical knowledge can make to health and well-being, as well as economic and social development in developing countries, by making findings freely accessible.
- Unlocking the potential contribution of developing country scientists and scholars to research by enabling their work and bringing it to the attention of researchers and users the world over.
- Removing competition authority concerns about the scholarly publishing industry (*e.g.* Competition Commission 2001; Office of Fair Trading 2002), by making publications and data openly available at marginal/zero cost to any organisation that wanted to add value (Newbery and Bentley 2008).

### ***3.3.2 Perform research and communicate results***

As authors, researchers stand to gain visibility through more open access and to see wider user made of their work. As users of the research of others, researchers stand to gain wider, faster and more complete access to the work on which they seek to build.

**For researchers and authors** the potential benefits of more open over toll restricted access include:

- Higher visibility within the research community, through increased access and citation, which may lead to further research funding, career advancement, etc. This visibility advantage applies to individual researchers, departments and research centres, and to their supporting institutions (*e.g.* universities).
- Greater visibility beyond the research community, among industry, government and community users, which may also lead to increased funding opportunities (*e.g.* contract research for industry and government). This visibility advantage also applies to individual researchers, departments and research centres, and to their supporting institutions.
- Greater support for a wider range of research practices, as OA self-archiving supports traditional outputs (*e.g.* journal papers) and new forms of output (*e.g.* data sets, audio and video, field and laboratory notes, etc.), thereby providing greater support for emerging as well as traditional modes of research and extending research possibilities (*e.g.* text mining, etc.).
- Greater support for interdisciplinary research, with cross-disciplinary teams able draw from literatures with which they may not have been familiar and to which they would not have subscribed as it was not core to their area.
- Greater support for collaboration between teams in different institutions and different countries, with everyone having access to the whole range of literature and to a wider range of content, rather than each being privy to different, limited and imperfectly matching silos.
- Greater support for inter-sectoral collaboration between researchers in universities, industry and government, with everyone having access to the whole range of literature (as above).
- Improved access making it easier to follow interesting ‘trails’ through the literature and to do so in real-time, rather than having to wait for delivery or getting sidetracked by access delays caused by authentication systems, searching for forgotten passwords, making toll payments and keeping track of related project accounts, etc.
- Improved access reducing the chances that something important might be missed and time wasted duplicating work that had already been done, pursuing blind alleys already explored but poorly reported (*e.g.* disinclination to publish negative findings), failing to use the latest techniques, etc.
- Improved access speeding up the research and discovery process, reducing the time needed to produce given results and, potentially, reducing the time that hypotheses that can be disproved are out in the research community awaiting rejection.
- Reduced cost and time in the checking of quotations and citations, compilation of references, etc. during the writing process, with links and references easier to trace and check.



- Reduced cost and time in the peer review process, with links and references easier to follow and check in an open access environment than one in which the authors and reviewers may have different levels and ranges of access.
- Reduction in the costs that copyright and IP and licensing restrictions impose in seeking permissions and/or paying to use the materials cited.
- More opportunity for humanities and social sciences scholars to publish books on the basis of merit rather than marketability (Bazerman *et al.* 2008), through new publishing opportunities, such as institutional e-presses based on OA repositories and print-on-demand, and the possible redirection of library serials subscription spending towards non-serial items.
- Time savings in the management of websites for individual researchers, centres and institutions, with institutional repositories offering the potential to centralise the holding and management of information, thereby making it easier for researchers to maintain a Curriculum Vitae and prepare funding applications from a common set of building blocks and existing data (*i.e.* ePortfolio, web résumé, etc.).
- Time savings in research project management and reporting by collecting and linking publications and other outputs automatically into individual and institutional research reporting and evaluation processes.

(See also the section 3.3.5 ‘*Study and apply knowledge*’, below).

### 3.3.3 Publish scientific and scholarly works

Scholarly publishers also stand to gain from more open access, with the opportunity to develop what are likely to be more sustainable business models and to develop new innovative services businesses through the provision of value-adding and overlay services.

**For publishers** the potential benefits of more open over toll restricted access include:

- The development of more sustainable business models, as subscription revenue is becoming difficult to sustain in the face of declining subscriptions (*e.g.* moving to ‘author-pays’ OA publishing would make revenue more predictable and stable as it scales more easily to research output than have library budgets, growing with research expenditure and providing a revenue stream that is growing) (*e.g.* Waltham 2006b). This reduced level of risk should, over time, be reflected in a reduced user cost of capital for OA publishers.
- That OA journals are more visible and more likely to attract submissions and advertising revenue, as well as readers and citations, thereby increasing potential revenue growth opportunities.
- That hybrid journals may also become more visible through offering open choice/author choice OA articles, and grow subscriptions and subscription revenue as a result.
- That journals that permit OA self-archiving (‘Green OA’) may become more attractive to authors, enabling them to raise the quality of their content over time, with flow-on to



citations, impact factor rankings and increased subscription and/or advertising revenues (Suber 2008).

- That OA publishing scales to submissions and provides a better platform for authors, as there are no necessary page limits per issue for online journals, which were set to control costs in the print era and forced the holding over of good papers until the next edition, adding to publishing delays (an oft cited concern of authors).<sup>47</sup>
- That OA publishing avoids the access control and authentication systems costs faced in toll access publishing, thus reducing the complexity and cost of platform and system development, and IT and technical user support (with access difficulties being a very common user support issue).
- The potential for OA repositories, and their supporting standards-based access systems, to further reduce the need for individual publishers to develop and operate expensive proprietary access systems (and the need for researchers to have to learn and use multiple interfaces).<sup>48</sup>
- Improved peer review, with speed and ease of access to cited material facilitating more efficient, more timely and potentially higher quality peer reviewing, enabling higher quality journal publishing, reducing costs and improving timeliness.
- OA would also allow publishers to draw on a wide network of reviewers, potentially reducing/spreading the burden of peer review and improving its quality (*e.g.* using more practicing professionals who without OA would have limited ability to check cited material for interpretation).
- Reducing the time and cost of handling permissions (to use and re-use), which may be simplified in any model, but most especially OA publishing, through the use of standard and/or more open licensing and blanket permissions.
- Reducing/eliminating publisher costs relating to licensing negotiations under the 'Big Deal' toll access model, which are avoided in OA publishing, as are costs relating to subscription price negotiations.
- Reducing publisher distribution costs, through the use of OA repositories (*e.g.* PubMed Central) or hosting services (*e.g.* HighWire) instead of using branded proprietary in-house systems for distribution.
- Providing new opportunities for services provision overlaying the open content (*e.g.* peer review, abstracting, searching, interrogating, etc.), as has happened in the cases of the open source software industry, weather derivatives industry, and a host of applications of geospatial information.

---

<sup>47</sup> OA publishing also allows publishers to focus on authors and their services to authors, rather than being divided between their authors and their subscribers.

<sup>48</sup> Because of their subject area or disciplinary focus OA archives can provide many of the features of traditional journals, such as subject specific alerting services relating to new deposits, thematically organised collections and associates (*e.g.* papers from a conference).

- Providing the opportunity for OA repositories to become the foundation for institutional e-presses, enabling them to fulfil their mission of publishing scholarly monograph materials to small specialist audiences, and enabling arts and humanities scholars to overcome what is an increasingly significant barrier to publication (Steele 2008).
- Providing the opportunity for learned societies and professional associations to raise their profile, and that of their discipline/profession, by publishing OA journals, hosting open access content (*e.g.* disciplinary OA repositories), etc., thereby encouraging membership growth.
- Providing the opportunity for learned societies and professional associations to develop new revenue streams, through the provision of overlay services (*e.g.* peer review, abstracting, specialist portals, etc.).

### 3.3.4 Facilitate dissemination, retrieval and preservation

Research infrastructure providers and managers also stand to gain through more open access, with the opportunity to develop integrated systems that accommodate all forms of research output and provide the foundation for e-science.

**For research infrastructure providers and managers** the potential benefits of more open over toll restricted access include:

- Providing the foundation for the integration of all the elements of the outputs of e-research (*i.e.* institutional repositories catering for all sorts of digital objects).
- Providing the foundation for long-term preservation (*e.g.* distributed preservation through institutional or subject repositories).
- Enabling the development of new mechanisms for collaborative research and underpinning new forms of research.
- Reducing the operational costs of libraries through the switch to OA ‘e-only’ content (*e.g.* less space, shelving, handling, etc.).
- Reducing costs relating to the use of multiple proprietary access control and authentication systems, in terms of IT system overheads, user support, development, implementation and operation of authentication systems, etc.
- Reducing the time and cost involved in negotiating the sometimes complex licensing agreements necessary to access the toll-gated literature.
- Reducing or eliminating copyright collection agency payments and reducing the cost of managing those payments, as well as reducing the operational costs of copyright collection agencies and, indirectly, the publishers and infomediaries that deal with them.
- Putting downward pressure on subscription prices and serials acquisition expenditures as a result of competition from the self-archiving of papers (*i.e.* providing a substitute (Bergstrom and Lavaty 2007)).

- Reducing or eliminating document delivery, ILL and reprint costs, as a result of either OA publishing or self-archiving.

### 3.3.5 *Study and apply knowledge*

**For research users** the potential benefits of more open over toll restricted access include:

- Easier access and reduced search and discovery time and cost (*e.g.* less reliance on multiple, poorly integrated proprietary interfaces, etc.).
- Reduced disincentive or compromise when access is open (*i.e.* using second best because its available).
- Less complication and uncertainty over permissions, with less time spent and fewer requests to use and/or reproduce open access material.
- Increased speed, with OA providing the latest results and findings without delay, especially where pre-prints are posted, but also because articles can be posted immediately on final acceptance without waiting for the next issue of the journal to be released (which could be done in any online business model).
- Reducing the chances of duplicative research being undertaken because others do not know of results of work that has been undertaken but not yet, or simply not, published.
- Making the supporting data available also avoids duplication of data collection and the costs involved in that (*e.g.* unnecessarily repeating questionnaire surveys, clinical trials, etc.) (which could be done in any online business model).
- Greater support for the emergence of new forms of research, by making the literature available so that it can be downloaded (copied), analysed and 're-used'.
- Greater support for education through ease of access for students and for teachers, reduced time and cost in compiling course related materials and learning objects, etc.
- Greater support for life-long learning and professional development, both within and outside formal education settings.
- The potential for wider access to reduce the cost of private investment in adoption and commercialisation of findings, and increasing returns to investment in R&D.
- The potential for wider access for healthcare workers, small firms in high-technology and knowledge-intensive industries, with positive impact on innovation, quality of service and productivity in those sectors of the economy.
- The potential for the emergence of new industries based on open access content (*e.g.* Weather Derivatives).
- Greater support for policy makers, industry, professional and lobby groups, enabling more informed policy debate, potentially leading to improved policy interventions and outcomes.

- Greater support for journalists, potentially enabling them to investigate issues more deeply and provide better secondary accounts of developments. In turn, this may spark interest and encourage young people to study and take up careers in science and academia, and may further increase visibility and use (Phillips *et al.* 1991; Kiernan 2003).
- Greater support for those seeking reliable medical information, be they patients or the families of patients, enabling them to better understand, cope with and manage medical conditions.
- Greater support for those seeking consumer information and seeking to better understand issues relating to standards testing and accreditation, pharmaceuticals and their potential effects and side-effects, etc.
- Greater support for those seeking to participate in public and policy debate, and seeking to better understand environmental issues such as climate change, etc.
- Greater support for those following a special interest or hobby (*e.g.* amateur astronomers, local historians, etc.), some of whom make a substantial ‘lay’ contribution to the field.

### 3.4 A brief summary of impacts and potential benefits

More open access to scientific and scholarly works has the potential to reduce costs, drive efficiency gains, create new opportunities and, by increasing use, help maximise the impact of research and increase the returns to public investment in it.

**Those funding and evaluating research** stand to gain from more open access through increased visibility, which may in turn make it easier for them to lobby for and raise additional funds. The costs faced by funders may be reduced in such areas as the collection of performance metrics and conduct of evaluation. Costs relating to external evaluation and peer review may also be reduced, and the quality of review may improve with the ease of its thorough conduct. Improved evaluation metrics and improved peer review might lead to better allocation of available funding, which may, in turn, lead to higher visibility and demonstrably greater quality and impact, and so on.

Conversely, a shift to publishing models supported by funder and/or author-side payments would re-direct a small percentage of research funding towards publishers (The Wellcome Trust suggest reported spending just over 1% of its annual research funding (Terry and Kiley 2006)), although this may be offset by reduced subscription costs for users and reduced time costs and resulting efficiency gains.

**Research organisations** providing support for the conduct of research, such as universities, stand to gain from enhanced access through increased visibility, potentially helping them to attract more research funding and student enrolments by both post-graduate research students and under-graduates. It might also assist in meeting industry and community engagement goals. The availability of institutional repositories (self-archiving) may also assist university and non-university research organisations in providing the e-research infrastructural support for new and

emerging research practices, intra- and inter-institutional and inter-sectoral collaboration, as well as helping to reduce the cost of research management and reporting. Universities and non-university research training organisations (*e.g.* ‘teaching’ hospitals) may also benefit from the capacity to store, manage and integrate a range of teaching and learning materials (*e.g.* ‘learning objects’, courseware, e-reserves, etc.).

Conversely, institutional repository costs would fall to the institutions and a shift to publishing models supported by institutional and/or author-side payments would require funding support for publisher charges, although both might be offset by reduced institutional subscription costs, with the balance of the impact depending on the research intensity of the institution and management of repository costs.

**For those performing and communicating research** more open access could help raise visibility among fellow researchers, within the research community more generally, in industry, government and beyond. In turn, this may lead to increased research funding and opportunities to advance the work. OA repositories can provide support for inter-disciplinary research and collaboration, as well as supporting new and emerging research methods and questions. Above all, more complete access is likely to: reduce the time wasted in duplicative work and the pursuit of blind alleys; help to reduce the cost and raise the quality of peer review (both in its conduct for others and application to oneself); reduce the cost and time wasted in navigating proprietary access systems and dealing with access barriers; reduce the time and cost of writing, proofing and checking; reduce the time and cost involved in seeking and obtaining permissions to use cited materials; and so on.

Conversely, as noted, OA publishers may charge author fees, thus raising the cost of publishing from the researchers’ perspective, and a small percentage of research time might be required for self-archiving.

**Those publishing scientific and scholarly works** also stand to gain from open access as it may provide an opportunity to shift towards more sustainable business models, as the traditional subscription publishing model becomes increasingly fragile and unsustainable in the online era. The increased visibility of titles may encourage more submissions and greater participation from external editors and reviewers, and make it easier to increase revenue from authors, advertisers and sponsors, all of which would be likely to improve the titles’ rankings, thereby creating a virtuous cycle. The ease and reduced cost of peer review and related possibility of quality improvement would also benefit publishers, helping to improve quality and enabling them to recruit reviewers from a wider field, which may also contribute to this virtuous cycle. Learned and professional society publishers could raise their visibility and profile, not only more effectively disseminating scholarly work in their area, but also potentially attracting greater membership and increased membership revenues.

OA publisher costs could be reduced through the use of OA repositories for hosting and dissemination and the avoidance of the development and implementation costs associated with proprietary in-house access systems. Even with proprietary access systems the removal of access barrier controls would reduce the complexity and costs involved (for all concerned). The costs of handling permissions and related copyright fees could also be reduced or avoided. Costs relating to the negotiation of licensing conditions and pricing could be avoided.

There is also a range of opportunities for smaller publishers, new publishing models, new value adding services and new revenue streams. Smaller publishers who have been locked out of the big publisher ‘Big Deal’ systems might gain from the ability to launch new titles and operate more cheaply, piggy-backing on existing hosting systems, the Internet and OA repositories for dissemination. And they could provide a voice for humanities and social science scholars seeking to publish research monographs, whose work deserves publication but is not sufficiently marketable to be considered (*e.g.* e-presses using the Internet, hosting services and repositories for dissemination). There would also be more opportunities in value adding services, such as peer review, search and discovery, interrogation and analysis, metrics and reporting, building on free access to OA content.

Conversely, there are inevitable transitional costs for all kinds of publishers and some uncertainty surrounding the nature of that transition. Some publishers worry that e-only publishing may affect advertising revenues, and society publishers fear loss of membership. However, these issues relate to the transition from print to electronic publishing, and not necessarily to that from toll access to OA. Indeed, as outlined, when combined with the reduced costs associated with e-only publishing, the potential benefits of OA publishing may well outweigh the potential costs of e-only publishing.

**Those facilitating the dissemination, retrieval and preservation** of scholarly works stand to gain from more open access through new, potentially lower cost opportunities to facilitate retrieval and preservation, building on a base of OA repositories. Library costs might be reduced through: reduced price and license negotiation costs; reduction of costs relating to providing and supporting access to multiple proprietary publisher access platforms, providing and managing authentication; reduced document delivery and ILL costs; reduced copyright collection agency payments; reduced serials acquisition costs (per item if not absolutely).

**For those studying and applying knowledge** more open access could be a major contributor. The risk of missing something important is reduced, as are the risks of duplicating work that has already been done – as a result of both the completeness of access possible and its immediacy. Costs and time would also be reduced, for all the reasons discussed above. There is also the potential for wider access to both accelerate and widen opportunities for adoption and commercialisation of research findings, thereby increasing returns on investment in R&D and reducing the cost of investment in its adoption, use and commercialisation.

There is also the potential for wider access for doctors and nurses, teachers and students, and small firms in high-technology and knowledge-intensive industries, with a positive impact on innovation, quality of service and productivity in those sectors of the economy. There may also be positive impacts on policy development, through better informed policy debate and enhanced access to the ‘science’ underpinning policy decisions. Potential benefits for the wider community include the more ‘informed citizen’ and ‘informed consumer’, with implications for better use of health and education services and better consumption choices leading to greater welfare benefits.

**For all those concerned with the future of research** more open access might contribute to speeding up the research and discovery process, creating a more complete record of science and making it more transparent and accountable, and expanding the contribution research can make

## Economic implications of alternative scholarly publishing models

to health and well-being, economic and social development in both developed and developing countries.

## Part II: Quantification of costs and benefits

Part II seeks, where possible, to quantify the costs and benefits identified in Part I; identify, and where possible quantify, the cost and benefit implications for each of the main players in the scholarly communication system; and, where possible, compare the costs and benefits of the three models for the main players in the scholarly communication system.

### 4 Quantifying costs

Part I presented a detailed life-cycle model of the scholarly communication process, in which the major process activities were identified as: (i) fund research and research communication; (ii) perform research and communicate the results; (iii) publish scientific and scholarly works; (iv) facilitate dissemination, retrieval and preservation; and (v) study publications and apply the knowledge. In quantifying the costs and benefits we deal with each of these in turn. In order to highlight key differences between scholarly publishing models, we focus on those areas in which the alternative models for scholarly publishing make a material difference.

#### 4.1 Fund research and research communication

Funding for research and research communication is substantial and rising. Government science allocations increased by around 5.5% per annum over the decade to 2006, in current values. The UK Science Budget for 2007-08 reported by DIUS is £3.4 billion, of which around £2.8 billion is channelled through the research councils (DIUS 2007, p29). The major charitable foundations operating competitive research grants programmes add significantly, with the Wellcome and Leverhulme Trusts alone allocating more than £400 million to research grants during 2006-07.

In the UK, gross expenditure on R&D (GERD) amounted to £23.2 billion during 2006, of which business expenditure amounted to £10.5 billion, government and higher education (including HEFCE and RCUK) expenditure amounted to £7.7 billion and other sources for the remaining £5 billion (National Statistical Office). These allocations flow to the performers of research such that, by sector of execution, the business sector spent £14.3 on R&D during 2006, the higher education sector just over £6 billion and the government sector £2.3 billion. An estimated 185,000 people were employed as active researchers in the UK during 2006-07, of which around 94,000 were in the business sector, 82,000 in higher education and 9,500 in government.<sup>49</sup>

In 2006-07, HESA reported total higher education research funding of just over £5 billion, implying a gap of around 20% between reported research funding and expenditure – made up

---

<sup>49</sup> Estimates of the number of active researchers in UK higher education institutions (HEIs) are based on the formulae which includes all university staff reported by HESA as research only plus half of those reported as teaching and research, thereby approximating fulltime equivalent (FTE) researchers. It excludes research students.



from other sources. Reported research funding accounted for around 25% of total higher education funding, and research active staff accounted for around 50% of total academic staff.

The funding and funder processes followed, and thereby the emphasis placed on various cost items, varies between agencies and the funding method or model itself. While the distinctions are not always clear, the emphasis on specific activities differs in the cases of block grant funding, competitive grants funding and contract funding.

- In the case of *competitive grants funding* through the research councils and major charitable foundations, there is greater emphasis on the peer review of applications and on monitoring the impacts and outcomes of grants and grant programmes. This entails internal management and review of applications and dependence on external advisors and peer reviewers, as well as efforts both internally and by the funded projects and supporting institutions in tracking and reporting against progress and evaluation criteria.
- *Block grant funding* is typically somewhat more ‘arms length’, tending to rely less on external peer evaluation of funding applications and more on more generic reporting and evaluation (e.g. the RAE/REF).
- Those offering *contract funding* typically deal more directly with the researchers on a project-by-project basis, and tend to focus on the more immediate and direct research outcomes.

The processes, time and costs involved are quite different. Nevertheless, with greater focus on justification, evaluation and reporting, there is increasing participation by funders in the research and scholarly communication cycle.

#### 4.1.1 Funding and agencies

The major costs faced by funding agencies include: the operation of funding agencies and of grant funds and programmes; the handling of grant application and their review and assessment; making funding decisions; the handling of project and fund reporting; and overall evaluation, public relations and lobbying (see the process model outlined in Part I and available at <http://www.cfses.com/EI-ASPM/SCLCM-V7/>)

The internal operational costs for funding agencies are not always clear. This is especially so where a charitable trust, such as the Wellcome Trust, operate both the trust funds under management and the associated research funding programmes, and/or where agencies perform other related functions, such as the operation of disciplinary data repositories. Nevertheless, recent S&T budget allocations report the aim of reducing operational costs to 2.92% of programme expenditure (DUIS 2007, p64). At around 3% of programme expenditure, the implied operational costs of the 2007-08 S&T budget would be around £100 million, and those of RCUK around £85 million. Almost £12 million was allocated for the operation of the RAE from 2004-05 through 2009-10, approximately £2.4 million a year.

**Box 4.1: Estimation assumptions: Fund research and communication**

| <b>Parameter</b>                           | <b>Basis</b>   | <b>Value</b>                                   |
|--|--|--|
| External peer review of grant applications | Tenopir and King (2000) time to review a journal article                     | 3 to 6 hours each, average 5 hours             |
| Peer reviews per grant application         | Research council consultation  | 2 to 5 per application, average 3              |
| Peer review costs                          | UK academic salaries including on-costs and overheads, using TRAC fEC method | £40 to £93 per hour, average £56 <sup>50</sup> |

Source: Authors' analysis.

### 4.1.2 Evaluation

The major costs associated with research evaluation by government (centrally), funding agencies and research institutions include:

- Collecting, collating and managing the necessary reporting, including costs associated with tracking and recording systems, the staff time involved in its management and the time that research staff and departments spend generating the reports, as well as developing and managing institutional and departmental strategies and responses;
- Collecting, collating and managing the necessary reporting to government, and the development and operation of supporting systems and processes; and
- Development of policy for evaluation, consultation and the development of indicators and metrics, collection and collation of reporting, preparation and 'publication' of results of evaluations, ratings and rankings, etc.

For competitive grants funding agencies the major cost drivers are the number of grant applications received and the level of project and programme reporting sought for evaluation.

In 2007, the Research Councils, Wellcome and Leverhulme Trusts reported the receipt of around 22,000 grant and award applications, of which some 6,200 were successful and received grants. It is estimated that internal management of evaluation and reporting account for around 50% of agencies' funding-related operational costs (*i.e.* perhaps around £40 million for the UK Research Councils alone).

Based on previous studies and consultation, we estimate the costs associated with the external peer review of competitive research grant applications in the UK at around £18.6 million a year circa 2007,<sup>51</sup> of which around £17.3 million related to higher education grants – reflecting a strong emphasis on competitive grants funding in higher education research.

<sup>50</sup> Academic salaries and overheads are based on standard days and hours of work, which to the extent that academics work more than their required hours will tend to inflate the costs involved. Nevertheless, the use of full economic costing is deemed the most appropriate approach.

<sup>51</sup> Costs are standardised throughout this report on 2007 prices and exchange rates, however some of the input data are in financial year rather than calendar year and may refer to 2006-07 and occasionally 2007-08. Hence, some costs are reported as 'circa 2007'.

### 4.1.3 Institutional

Major cost items faced by research institutions, such as universities, included those relating to research management, grant application preparation, grant application handling, grant application reviews and project reporting.

Most research institutions, including universities, operate research offices to coordinate funding applications and reporting. Unfortunately, practices vary considerably – with some institutions operating centralised management and reporting through large research offices, while others operate relatively small research offices and decentralised management and reporting in which the faculty and departments carry much of the burden internally. As a result, the operational costs of institutional research offices tell us little about the activity costs involved. Nevertheless, these costs will be included as overheads in the overall system costs outlined herein as a result of using full economic costing.

**Table 4.1: Estimated annual costs: Fund research and communication (GBP, circa 2007)**

| <i>Activity / Item</i>                          | <i>Estimate</i> |
|---|-----------------|
| Estimated operation costs of overall S&T budget | 101,500,000     |
| Estimated RCUK operational costs                | 85,000,000      |
| Operation of RAE                                | 2,400,000       |
| External grant application reviews (National)   | 18,600,000      |
| External grant application reviews (HE)         | 17,300,000      |

Source: EI-ASPM model: Authors' analysis.

### 4.1.4 Resources

The resources involved in funding research and research communications include: manual and IT systems; IT and supporting infrastructure; specialist skills and services; and research evaluation metrics. Again little is known, although for those research councils reporting IT costs they range from 6% to almost 10% of operational costs. These costs will also be included in the overall system costs outlined as a result of using full economic costing.

### 4.1.5 The implications of alternative publishing models for research funders

Major areas of impact include the potential information access and handling efficiency gains for all of the parties involved and enhanced visibility on the benefits side, and the diversion of research funding directly to fund author- or producer-side payments in an OA publishing model on the cost side. With limited information available the best one can do is to explore these in terms of a number of plausible scenarios. These relate to funding agency activities and grants funding, principally to higher education, with system-wide impacts explored elsewhere.

### Box 4.2: Scenario assumptions: Fund research and communication

| <b>Parameter</b>   | <b>Basis</b>   | <b>Value</b>             |
|--|--|--------------------------|
| Funder operational costs as a share of funding           | UK S&T Budget document   | 3%                       |
| Evaluation and reporting as a share of operational costs | Authors' estimate  | 50%                      |
| Potential savings in these costs from enhanced access    | Authors' estimate  | 5% to 10%, estimate 5%   |
| Returns to publicly funded R&D                           | Literature review (conservative consensus from the literature) | 20% to 60%, estimate 20% |
| Improved allocations increase returns to R&D             | Authors' estimate  | 1% to 5%, estimate 2.5%  |
| Increase in allocations to R&D                           | Authors' estimate  | 1% to 5%, estimate 2.5%  |

Source: Authors' analysis.

### Funding agency and related costs

#### Scenario: Savings for funding agencies in internal evaluation of proposals, evaluation of impacts and reporting, and in lower cost of "lobbying" for funds

With estimated funding agencies operational spending at £87.4 million per annum in 2007 (RCUK and RAE), management, evaluation and reporting activities would cost around £44 million, and the potential 5% internal saving from enhanced access would be worth around £2.2 million per annum (excluding potential external peer review savings).

#### Scenario: Funder savings spent on R&D

If these savings flowed through to research in the form of an equivalent increase in research funding (assuming no substitution at the margin), the implied annual impact on returns to R&D would be around £440,000 (at average returns).<sup>52</sup>

#### Scenario: Savings in external evaluation of proposals (peer review)

With estimated costs of external grant application reviews at around £18.6 million nationally and £17.3 million in higher education circa 2007, the potential 5% annual savings from enhanced access would be worth around £865,000 for higher education and £930,000 nationally in 2007 prices and levels of grant applications and funding.

<sup>52</sup> These are recurring gains, albeit lagged to account for the time between the conduct of research and its impacts. Such returns can be expressed in Net Present Value (NPV), lagged and recurring over the useful life of the knowledge. However, NPV calculations are sensitive to the discount rates applied. For example, lagged 10 years and recurring for 10 years thereafter the £440,000 would be worth around £330,000 (NPV) using a very conservative discount rate of 10% per annum, and around £600,000 (NPV) at 5%. While one might choose a real discount rate of 7%, returning around £470,000, we have taken the view that for the sake of simplicity and transparency we will simply take the original number (*i.e.* £440,000) as indicative of the value of the returns.

**Scenario: Improved quality of peer review and better evaluation metrics lead to better allocations and raise returns to R&D**

With grant and block funding to higher education institutions at £3.6 billion in 2006-07 (*i.e.* that share of funding most directly affected by research evaluation), a 2.5% increase in returns to R&D due to improved targeting and allocation would be worth around £18 million per annum in higher education alone (at average returns).

**Scenario: Increased visibility leads to increased R&D allocations, and thereby to increased impacts**

With grant and block funding to higher education institutions at £3.6 billion in 2006-07, a 2.5% increase would be worth £150 million with implied additional annual returns of £30 million (at average returns).

**Scenario: All of the above scenarios are combined**

Combined (*i.e.* simply combined rather than cumulative and excluding the savings relating to external peer review) these potential savings and impacts would be worth around £50 million per annum at 2007 prices and levels of funding.

## OA publishing fees

**Scenario: Some proportion of R&D funding is diverted to pay OA publishing fees (be it author-pays or other producer-side fees)**

The potential impacts of OA publishing on costs and funding flows are difficult to estimate as OA publishing costs and/or fees can and are being met from a variety of sources, with perhaps less than one-half of OA journals charging author fees and the potential for other revenue streams (*e.g.* advertising, membership fees, etc.) to complement and reduce the author fees charged even by those journals that do, and emerging OA book publishing models as yet too embryonic to be readily classified.

The details of OA article publishing fees estimates are discussed in section 4.4 (below), and their system-wide impacts are dealt with elsewhere. In this section we focus on the cost and funding flow impacts relating to research funding bodies – in isolation from other system actors.

If author/producer-side fees sufficient to cover the entire costs of OA journal publication had been paid for all articles produced within UK higher education during 2007, we estimate that the total cost would have been around £148 million, or 2.4% of higher education R&D expenditure (HERD).<sup>53</sup> Had these simply reduced HERD by 2.4% there would have been an implied loss of returns to R&D of around £30 million per annum (at average returns, 2007 prices and levels of funding). Thus the net cost would have been of the order of £177 million per annum circa 2007.

There is insufficient information to estimate the costs of OA book publishing to funders as there is as yet no comparable process or business model for research monographs.

---

<sup>53</sup> Nationally, author/producer-side fees sufficient to cover the entire costs of OA publication for all articles produced in the UK during 2007, would have been around £170 million.

## Funder-side costs and savings

### Scenario: comparing funder-side costs and savings

Combining these funder-side costs and savings as they relate primarily to UK higher education would imply potential savings of around £50 million per annum from enhanced access, and costs of entirely funder-side supported OA publishing (*i.e.* a system in which all producer-side publishing fees were met from research grants) of around £175 million per annum at 2007 prices and levels of activity, leaving a shortfall of around £130 million per annum to be recouped from elsewhere.

Of course, it is most unlikely that an entirely funder supported producer-side OA publishing system would arise, so this is in some senses a ‘worst case’ scenario, intended to scope the potential quantum of cost and funding flow impacts. It does not take account of potential cost and funding flow impacts elsewhere in the system. More importantly, it is simply net of costs and does not take account of the potential impact of enhanced access on returns to R&D (discussed in sections 5 and 6, below).

## 4.2 Perform research and communicate the results

The activities involved in performing research and communicating results are outlined in Part 1 (<http://www.cfes.com/EI-ASPM/SCLCM-V7/>). Based on a variety of surveys and studies of the activities of researchers it is possible to estimate the costs involved in the performance of research and research communication in UK higher education and, to a lesser extent, in the UK nationally (See Box 4.3).

Costings are based on UK academic salaries during 2007 with on-costs and overheads calculated according to the UK’s full economic costing method (TRAC FEC), converted to an hourly cost at official working hours. To the extent that researchers work longer than official working hours without additional pay this may lead to a slight overstating of costs. Nevertheless, as the UK higher education sector is moving towards the full economic costing of research it seems appropriate to employ full economic costing for our estimations. All costs are expressed in 2007 UK pounds and, where necessary, have been converted to pounds using OECD published annual average exchange rates and adjusted to 2007 using the UK consumer price index published by the National Statistical Office.

### 4.2.1 Perform research

**Reading:** Reading is a major activity for researchers. We estimate that, on average, reading may occupy around 30% researchers’ time, costing around £7.7 billion in the UK nationally in 2007, of which higher education institutions accounted for around £5 billion (Table 4.2). Reading by those actively publishing (*i.e.* approximating reading in order to write) is estimated to have cost around £2.8 billion nationally, of which higher education accounted for around £2.4 billion – with a much higher proportion of active authors among researchers in higher education than elsewhere.

Nationally, we estimate that the cost of reading by researchers in 2007 included around £1.8 billion for journals articles, £4.3 billion for monographs and more than £1.6 billion for conference papers, reports and other materials. In UK higher education, we estimate the breakdown of reading costs to be £1.4 billion for journal articles, around £2.7 billion for monographs and almost £1 billion for other materials.

**Box 4.3: Estimation assumptions: Perform research and communicate results**

| <b>Parameter</b>   | <b>Basis</b>   | <b>Value</b>   |
|--|--|--|
| Time to write a journal article                                  | Tenopir and King (2000), King (2004)                                       | 90 to 100 hours, average 95  |
| Time to peer review an article                                   | Tenopir and King (2000), King (2004)                                       | 3 to 6 hours, average 4.5  |
| Number of peer reviewers per article                             | Tenopir and King (2000)  | 2 to 3 reviewers, average 2.5  |
| Rejection and resubmission (article)                             | Authors' estimate  | 50% rejected of which 60% are sent for external review and 40% rejected without review, and of which 75% are resubmitted once  |
| Number of peer reviewers per monograph                           | Industry consultation  | 2 to 3 reviewers, average 2  |
| Rejection and resubmission (monograph)                           | Authors' estimate  | 20% rejected of which 50% are resubmitted once   |
| Time spent on editorial activities                               | Industry consultation  | 10 to 30 days per annum, average 20  |
| Time spent on editorial board activities                         | Industry consultation  | ½ to 1 day per year, average ¾   |
| Percentage of authors who are editors and/or on editorial boards | Rowlands and Nicholas (2005)   | 8% and 24%, respectively   |
| Number of readings per researcher per year                       | Tenopir and King (2000), tracking studies and Tenopir <i>et al.</i> (2008) | Industry/higher education: <ul style="list-style-type: none"> <li>• Articles 130/270 rising to 280</li> <li>• Books 53/48</li> <li>• Reports 65/46</li> <li>• Trade literature 51/74</li> <li>• Other items 22/14</li> </ul> |
| Time spent reading an article                                    | Tenopir and King (2007) and Tenopir <i>et al.</i> (2008)                   | 34 minutes falling to 31, but slightly higher for research, estimate 31  |
| Time spent searching for and accessing an article                | Tenopir and King (2007), CEPA (2008) and Tenopir <i>et al.</i> (2008)      | 8 to 17 minutes, average 12.5 but falling, estimate 12.5   |
| Article requests per reading                                     | Tenopir and King (2000), CEPA (2008)                                       | 1.3 to 1.4   |
| Time spent by author obtaining permissions per article           | Halliday and Oppenheim (1999)  | 1 to 4 hours, average 2  |
| Percentage of articles photocopied or printed                    | CEPA (2008) and Tenopir <i>et al.</i> (2008)                               | 20% print, 69% electronic  |
| Cost of printing and copying per page                            | SCONUL   | 5 pence per page   |
| Time spent printing or copying an article                        | Authors' estimate  | 1 to 5 minutes, average 3  |

Source: Authors' analysis.



**Search and discovery:** Searching for and obtaining material to read also takes time, and based on reported average requests per reading we estimate that researchers spend between 60 and 180 hours per year searching and accessing reading materials, depending on reading habits. Nationally, circa 2007, this translates to an estimated annual cost of £1.4 billion, of which some £615 million relates to higher education – reflecting a wider readership than authorship, even among researchers. Of these totals, searching for and obtaining journal articles accounts for an estimated £850 million per annum nationally and £375 million in higher education.

**Table 4.2: Estimated annual costs: Perform research and communicate results – research related (GBP, circa 2007)**

| <i>Activity / Item</i>                            | <i>Estimate</i>             |
|---|-----------------------------|
| <b>READING</b>                                    |                             |
| <b><i>Reading per year (National)</i></b>         | <b><i>7,729,200,000</i></b> |
| Papers (journal)                                  | 1,806,600,000               |
| Books (monographs + edited books)                 | 4,282,900,000               |
| Other (Conference papers, Reports, etc.)          | 1,639,700,000               |
| Cost of reading by authors (National)             | 2,775,000,000               |
| <b><i>Reading per year (Higher Education)</i></b> | <b><i>5,097,500,000</i></b> |
| Papers (journal)                                  | 1,379,200,000               |
| Books (monographs + edited books)                 | 2,745,800,000               |
| Other (Conference papers, Reports, etc.)          | 972,500,000                 |
| Cost of reading by authors (HE)                   | 2,446,000,000               |
| <b>WRITING</b>                                    |                             |
| <b><i>Writing per year (National)</i></b>         | <b><i>1,599,700,000</i></b> |
| Papers (journal & conference)                     | 665,400,000                 |
| Books (monographs + edited books)                 | 838,200,000                 |
| Chapters  | 96,200,000                  |
| <b><i>Writing per year (Higher Education)</i></b> | <b><i>1,453,900,000</i></b> |
| Papers (journal & conference)                     | 550,300,000                 |
| Books (monographs + edited books)                 | 817,600,000                 |
| Chapters  | 86,100,000                  |
| <b>SEARCH &amp; DISCOVERY</b>                     |                             |
| Search and Discovery (National researchers)       | 1,398,100,000               |
| Search and Discovery (HE researchers)             | 616,500,000                 |
| <b>PRINTING &amp; COPYING (Higher Education)</b>  |                             |
| Print and copying (UK HEIs)                       | 26,300,000                  |
| Total including time spent (UK HEIs)              | 105,200,000                 |
| <b>PERMISSIONS</b>                                |                             |
| Cost to authors (National researchers)            | 23,200,000                  |
| Cost to authors (HE researchers)                  | 20,600,000                  |

Source: EI-ASPM model: Authors' analysis.



**Printing and copying articles:** In order to study material in detail researchers have often made a photocopy of printed material and/or printed electronic material. There is insufficient information to estimate the costs involved nationally, but in UK higher education where more is known about modes of access and delivery formats we estimate that it cost of the order of £26 million in journal article print and copy costs per annum in 2007 prices (£6 million for copying and £20 million for printing). The time spent doing it is more significant, and assuming average academic salary levels may have cost around £80 million during 2007. This would imply printing and copying costs of around £105 million per annum in higher education alone in 2007 prices.

#### 4.2.2 *Communicate research*

**Writing:** Time spent writing formal publications can be considerable, with the extensive surveys of Tenopir and King (2000, etc.) suggesting that an average of 90 to 100 hours may be spent preparing a journal article. At the levels of UK publishing output during 2007, we estimate that writing formal publications may have cost around £1.6 billion a year in the UK, of which higher education may have accounted for more than £1.4 billion – reflecting relative levels of authorship within higher education (Table 4.2).<sup>54</sup>

Nationally, we estimate that writing journal articles and refereed conference papers cost around £665 million, writing books around £840 million and book chapters a further £95 million. Of these national totals, higher education would have accounted for around £550 million of the costs of writing journal articles and conference papers, £820 million of the book writing costs, and £86 million of the book chapter writing costs.

**Permissions:** Obtaining permissions to use copyrighted material is often a requirement for publishing and occupies authors' time.<sup>55</sup> There is insufficient information to estimate the cost of permissions *per se*, but even if permissions were all granted free of charge the time spent by authors seeking permissions remains. Based on publishing levels in 2007, we estimate that authors' time spent on obtaining permissions may have cost around £23 million during the year in the UK, mostly in higher education.

#### 4.2.3 *The publisher-related activities of researchers*

Researchers participate in the scholarly publishing process as journal editors, members of editorial boards and peer reviewers, as well as being authors and readers. One might expect that those in such roles would be relatively senior and earning somewhat above average salaries. Hence, it is likely that the following estimates may somewhat understate the costs involved. They are scaled to research output, reflecting participation in the scholarly publishing process, and assume that international reviewing cancels out, which in so far as the UK may carry a

---

<sup>54</sup> Publication output was estimated from Web of Knowledge searches, scaled to reflect the scope and content coverage of Web of Knowledge.

<sup>55</sup> OA publishing and the use of more flexible and standardised licensing (*e.g.* Creative Commons) reduce the need for permissions.

higher review load than its publishing contribution (*e.g.* because of English language bias) may also lead to some understatement.

**Peer review:** Peer review plays a key role in scholarly publishing, with much of the actual review work undertaken by researchers. It is often, but not always, unpaid work. Nevertheless, there are costs associated with it – primarily in terms of the time spent.

Based on widely cited surveys we estimate that the time spent by researchers on peer review activities in the UK in 2007 cost around £200 million, of which £165 million related to review of journal articles and conference papers, and the remainder to books, book chapters and other materials. Of these totals, higher education accounted for around £180 million, with £140 million of that relating to journal articles and conference papers.<sup>56</sup> Much of this cost is borne by the researchers' employing institutions.

**Table 4.3: Estimated annual costs: Perform research and communicate results – publisher related (GBP, circa 2007)**

| <i>Activity / Item</i>                                | <i>Estimate</i>    |
|---|--------------------|
| <b>PEER REVIEW</b>                                    |                    |
| <b><i>Peer review per year (National)</i></b>         | <b>202,800,000</b> |
| Papers (journal & conference)                         | 163,100,000        |
| Books (monographs + edited books)                     | 27,300,000         |
| Chapters  | 12,500,000         |
| <b><i>Peer review per year (Higher Education)</i></b> | <b>178,600,000</b> |
| Papers (journal & conference)                         | 140,800,000        |
| Books (monographs + edited books)                     | 26,600,000         |
| Chapters  | 11,200,000         |
| <b>JOURNAL EDITORIAL</b>                              |                    |
| <b><i>Editorial activities (National)</i></b>         | <b>70,600,000</b>  |
| Editor activities                                     | 63,600,000         |
| Editorial board activities                            | 7,000,000          |
| <b><i>Editorial activities (Higher Education)</i></b> | <b>61,000,000</b>  |
| Editor activities                                     | 54,900,000         |
| Editorial board activities                            | 6,100,000          |

Source: EI-ASPM model: Authors' analysis.

**Editorial activities (journals):** The time spent by researchers in acting as journal editors can be significant, and we estimate that it may have cost UK research institutions around £65 million during 2007, of which around £55 million related to higher education (Table 4.3).

Many researchers serve on journal editorial boards, and while the implied time commitments vary substantially we estimate that the cost may have amounted to some £7 million nationally in the UK during 2007, of which £6 million related to higher education.

<sup>56</sup> We take no account of the review work relating to working paper series, research reports or other outputs.

Thus, these journal related editorial activities alone may cost more than £70 million per annum nationally, at 2007 prices and levels of activity, of which more than £60 million may have been borne by higher education.

#### 4.2.4 Research infrastructure

**Preparation of grant applications:** The preparation of research grant applications is an important part of the research communication life-cycle, and we estimate that it may have cost around £120 million in the UK circa 2007, of which perhaps £110 million related to higher education (Table 4.4).

**Review of grant applications:** Researchers also act as peer reviewers of research grant applications on behalf of the competitive grants funding agencies. Based on the number of applications received by RCUK and the Wellcome and Leverhulme Trusts alone during 2007, we estimate that the external peer reviewing of research grant applications for these funding bodies cost around £19 million, of which £17 million related to higher education.

Table 4.4: Estimated annual costs: Perform research and communicate results – research grants (GBP, circa 2007)

| <i>Activity / Item</i>                              | <i>Estimate</i>    |
|---|--------------------|
| <b>RESEARCH GRANTS</b>                              |                    |
| <b><i>Grant applications (National)</i></b>         | <b>136,100,000</b> |
| Preparation of grant applications (National)        | 117,500,000        |
| Review of grant applications (National)             | 18,600,000         |
| <b><i>Grant applications (Higher Education)</i></b> | <b>126,800,000</b> |
| Preparation of grant applications (HE)              | 109,500,000        |
| Review of grant applications (HE)                   | 17,300,000         |

Note: Includes grants relating to the UK Research Councils (RCUK), Wellcome and Leverhulme Trusts only.

Source: EI-ASPM model: Authors' analysis.

**Equipment and facilities:** The equipment and facilities supporting research activities represent a substantial cost, but because of the inclusion of overhead costs in the full economic costing of activities these costs are accounted for in the system costings. Consequently, few such costs have been estimated in isolation.

Nevertheless, UCISA reported that centralised spending on ICT infrastructure and services in UK higher education amounted to an average of around 5.6% of total spending, or an estimated £1.3 billion during 2005-06. By no means all spending is centralised.<sup>57</sup>

<sup>57</sup> Research library and related infrastructure is dealt with in Section 4.4 (below).

#### 4.2.5 *The perform and communicate research cost implications of alternative publishing models*

Major areas of possible impact include the potential for more open access to improve accessibility and reduce the cost involved for researchers in discovering, accessing and obtaining material needed for their research, and in possible efficiency gains realised through avoiding duplicative work, the pursuit of blind alleys and speeding up the discovery process. Again we explore some plausible scenarios to provide some insights into potential cost impacts.

##### Cost savings and impacts

###### **Scenario: Reduced search, discovery and access time through enhanced discoverability and greater access, and less use of proprietary silo access systems**

If easier access resulted in a 5% reduction in researcher search and discovery time, then on the basis of the estimates outlined above it would imply an annual saving of around £70 million in 2007 prices nationally in the UK, and around £30 million in higher education. Were the potential time savings available for journal articles alone, the annual savings would be of the order of £42 million and £19 million, respectively.

###### **Scenario: Less time spent on seeking and obtaining permissions to use (copyright and licensing)**

OA publishing is often less restrictive than toll access publishing in terms of the permissions automatically granted to users (*e.g.* creative commons licensing), making for potential savings in the cost of researcher authors seeking and obtaining permissions of around £12 million nationally and £10 million in higher education – at 2007 prices and levels of publishing. Were the potential time savings available for journal articles alone, the annual savings would be of the order of £6.4 million and £5.5 million, respectively.

###### **Scenario: Less time spent on checking references and interpretations in peer review through greater ease of access, in turn making for better quality review**

If more open access saved 10% of the time spent performing peer review of publications, the implied annual cost saving would have been £20 million during 2007 nationally, of which more than £18 million could have been saved in higher education. Were the potential time savings available for journal articles alone, the annual savings would be of the order of £16 million and £14 million, respectively.

Similar time savings in performing peer review of competitive research grant applications would imply annual cost savings of £1.9 million during 2007 nationally, of which £1.7 million could have been saved in higher education.

Combined, these potential savings in the cost of performing peer review might amount to around £22 million nationally and £20 million in higher education.

**Scenario: Less time spent on writing and preparation through greater access making reference checking, etc. easier**

If enhanced access led to a 5% saving in publication writing and preparation time, it could have saved £80 million per annum nationally at 2007 prices and levels of publishing activity, of which an estimated £73 million would have accrued in higher education. Were the potential time savings available for the writing and preparation of journal articles alone, the annual savings would have been of the order of £33 million and £28 million, respectively.

Similar time savings in the preparation of research grant applications would imply annual cost savings of £5.9 million during 2007 nationally, of which £5.5 million could have been saved in higher education.

Combined, these potential savings in the cost of writing and preparation might amount to £86 million nationally, and £78 million in higher education.

**Box 4.4: Scenario assumptions: Perform research and communicate results**

| <b>Parameter</b>  | <b>Basis</b>      | <b>Value</b>             |
|---|-------------------|--------------------------|
| Search, discovery and access time saving through more open access | Authors' estimate | 5% to 10%, estimate 5%   |
| Permissions time saving through more open access                  | Authors' estimate | 40% to 60%, estimate 50% |
| Peer review time saving through more open access                  | Authors' estimate | 5% to 20%, estimate 10%  |
| Writing and preparation time saving through more open access      | Authors' estimate | 5% to 10%, estimate 5%   |

Source: Authors' analysis.

**Scenario: Sum of cost implications for research expenditures and returns**

Combined (*i.e.* the simple sum of these savings), these potential annual savings from more open access, would amount to an estimated £190 million nationally at 2007 prices and levels of publishing activity, of which £140 would accrue in higher education – equivalent to around 3.4 million hours of research time annually for the UK nationally, of which 2.5 million research hours in higher education.

These cost savings in the conduct of research effectively increase available research time/spending, thereby generating additional annual returns to publicly funded R&D of some £38 million per annum nationally at 2007 levels of R&D spending, of which £28 million would have come from higher education research activities. Hence, the overall impacts of these potential annual savings would amount to an estimated £227 million nationally circa 2007, of which around £167 million would have come from higher education.

It should be noted that these impacts are quantitative and do not include the value of possible improvements in quality of grant applications and publications, or in their peer review, or of research more generally.

## 4.3 Publish scientific and scholarly works

The activities involved in publishing scientific and scholarly works are outlined in Part I (See <http://www.cfses.com/EI-ASPM/SCLCM-V7/>).

The costs reported here are those faced by publishers and, as such, are a sub-set of publishing costs, which include costs faced by other actors in the scholarly communication system (*e.g.* authors and reviewers). All costs are expressed in 2007 UK pounds and, where necessary, have been converted to pounds using OECD published annual average exchange rates and adjusted to 2007 using the UK consumer price index published by the National Statistical Office. These costs include commercial (profit) margins.

### 4.3.1 Journals

Journal publisher costs include establishment, operational costs and overheads. In the following analysis, we focus primarily on operational costs and overheads as establishment costs are included as a part of the management and investment margins. Costings are based on a number of assumptions about key variables (See Box 4.5).

#### Article processing

##### *Peer review*

Article processing costs include the handling of submissions and initial internal review for subject and suitability, and the handling of the external peer review process. These publisher-side peer review costs are driven by the number of article submissions, rather than articles published, and vary with rejection rates. However, at an average rejection rate of 50% (40% to 60%), based on the Tenopir and King (2000) estimate of USD 20 per page received we estimate publisher-side peer review costs at an average of around £344 per article published in 2007 prices.

External peer review costs were discussed as a part of performing research and communicating the results. Practices vary, but at an average of 2.5 reviewers taking an average 4.5 hours per review the costs would amount to around £630 per article reviewed (including those rejected and re-submitted) at average researcher salaries (*i.e.* average UK academic salaries, on-costs and overheads). Equivalent to around £1,390 per article published (with some rejected without going to external review).

##### *Editing, composition and typesetting*

Based on the Tenopir and King (2000) estimate of USD 50 per page, we estimate that editing and proofreading costs an average of around £480 per article published; and based on their estimate of USD 35 per page, we estimate that composition and typesetting in the print environment costs an average of around £335 per article published. Illustration and graphics were estimated at USD 60 per page by Tenopir and King (2000), and at today's prices that would be around £45 per article published. Self-evidently, these per article costs vary with the number of pages per article and special graphics needs.

## Box 4.5: Estimation assumptions: Publish scholarly works (Journals)

| <b>Parameter</b>   | <b>Basis</b>   | <b>Value</b>   |
|--|--|--|
| Pages per article  | Tenopir and King (2000) and tracking studies, CEPA (2008), King <i>et al.</i> (2008) | 11.7 to 14.3, estimate 12.4                            |
| Articles per issue   | Tenopir and King (2000), CEPA (2008)   | 10 to 20, estimate 10                                  |
| Issue per year   | Tenopir and King (2000) and tracking studies, CEPA (2008)                            | 8 to 16, estimate 12                                   |
| Articles per title per year (in the location of the average article) | Tenopir and King (2000) and tracking studies, Björk <i>et al.</i> (2008)             | 50 to 150, estimate 120 (see footnote) <sup>58</sup>   |
| Non-article content pages  | King (2007), King <i>et al.</i> (2008)   | 10% to 20%, estimate 14%                               |
| Article rejection rate   | Consensus from literature  | 40% to 60%, estimate 50% (20% rejected without review) |
| Subscriptions per title  | Tenopir and King (2000), CEPA (2008)   | 300 to 3,000, estimate 1,200                           |
| Management and investment margin                                     | CEPA (2008)  | 20% to 25%, estimate 20%                               |
| Surplus / profit margin  | CEPA (2008) adjusted   | 10% to 30%, estimate 20%                               |
| E-only delivery and fulfilment (relative to print)                   | CEPA (2008), Waltham (2005)  | 25%  |
| E-only content processing (relative to print)                        | CEPA (2008), Waltham (2005)  | 25%  |
| OA rights management (relative to toll)                              | Authors' estimate  | 20%  |
| OA user support (relative to toll)                                   | Authors' estimate  | 20%  |
| 'Author-pays' marketing and support costs (relative to toll)         | Authors' estimate  | 33%  |
| OA hosting (relative to toll)  | Authors' estimate  | 50%  |
| OA management and Investment (relative to toll)                      | Authors' estimate  | 75%  |
| OA surplus/profit (relative to toll)                                 | Authors' estimate  | 75%  |

Source: Authors' analysis.

Waltham (2005; 2006) is among a number of analysts to have pointed to considerable cost savings in an electronic (e-only) environment, suggesting that e-only typesetting and graphics costs could be as low as 10% of equivalent print costs. Taking a more conservative approach we assume 25%, and estimate that e-only composition and typesetting costs would be around £85

<sup>58</sup> The number of articles per title per year varies widely, and is typically higher in Sciences than Humanities. Reported averages range from 57 (for all journals in all fields) to 154 (for a sample of science titles), with Björk *et al.* (2008) reporting an average of 111 for ISI listed journals for all fields and 26 for titles outside ISI (overall average 57) and King reporting 114 worldwide from a sample of science and social science titles. Despite the convergence on 111 to 114, both may be biased upward as the ISI listing may contain more established and more science-based journals and the King sample excludes humanities. However, we are looking at the cost of the average article rather than average title, and given the distribution the average article will be in a title with a higher number of articles than is average across titles. Hence an estimate of around 120 would seem reasonable (*i.e.* the average article appears in a title with around 120 articles per year).



per article and illustration and graphics £12 per article. Quality assurance for e-content is estimated to cost around £30 per article published, based on ALPSP publisher reports.

### Non-article processing

Non-article processing includes preparation and processing of non-article journal content, such as covers, indexes, editorial and review content, and costs vary with the proportion of non-article to article content. Based on the Tenopir and King (2000) estimate of USD 65 per page and the King (2007) report that between 17% and 38% of journal pages were non-article content, subsequently updated in King and Alvarado-Albertorio (2008) to 14%, we estimate that non-article content processing costs average around £1,010 per issue or around £100 per article in 2007 prices.

Again, Waltham (2005; 2006) suggested that e-only processing costs could be as low as 10% of equivalent print costs, and again taking a more conservative approach we assume 25% and estimate that e-only non-article processing costs average around £253 per issue or £25 per article.

### Other costs

Other costs driven primarily by the number of articles published include:

- **Rights management:** Based on CEPA (2008), we estimate rights management costs at around £50 per article for toll access copyright-based publishing, and £10 per article for OA publishing – with standard licensing agreements progressively replacing individual copyright assignment.
- **Author-side payments processing:** For the author-side fee model of OA publishing the cost of processing author-side payments is estimated at £20 per article, based on CEPA (2008) estimates.
- **Marketing:** Drawing on a range of sources, we estimate marketing costs at £120 per article for the subscription model and a conservative £40 per article for the OA publishing model (*i.e.* marketing to authors).
- **Online hosting:** Following CEPA (2008) we estimate online hosting costs per article at £200 for the subscription model, and £100 for the OA publishing model – with less use of proprietary access systems and no need for access control and authentication in the latter.
- **Customer service/helpdesk:** Following CEPA (2008) we estimate the cost of operating customer service/helpdesk at £50 per article for the subscription model, and £10 per article for the OA publishing model – with no subscriber access problems to deal with in the latter.

Other costs driven primarily by the number of subscribers include:

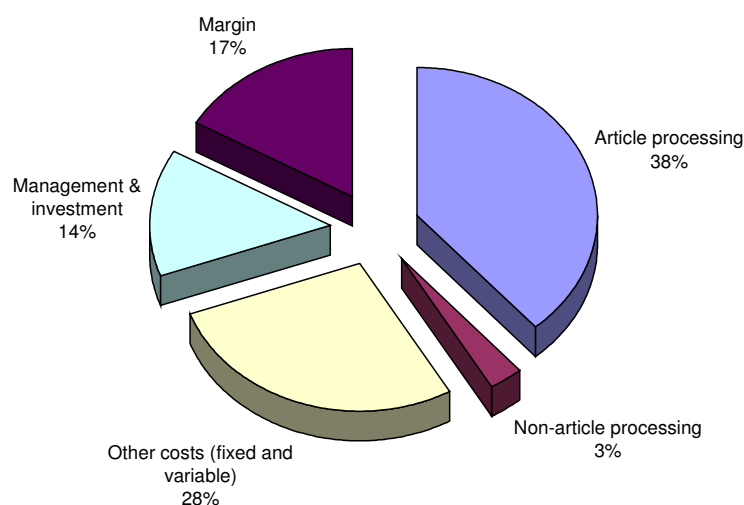
- **Sales administration and online user management:** For the subscription model, sales administration and online user management are estimated to each cost £10 per



subscriber (CEPA 2008).<sup>59</sup> Costs per article vary with the number of subscribers, but at an average of 1,200 subscribers this would be equivalent to around £100 per article published.

- **Printing and inventory management:** For the print subscription model, printing and inventory management costs are estimated to be around £15 per subscriber, or approximately £150 per article (Tenopir and King 2000; CEPA 2008).
- **Delivery and fulfilment:** Based on the Tenopir and King (2000) estimate of USD 14 per subscriber, we estimate print delivery and fulfilment costs at around £12 per subscriber in today's prices. Following CEPA (2008) we estimate e-only delivery and fulfilment costs at 25% of those of print, or £3 per subscriber. These costs would equate to approximately £120 and £30 per article, respectively, depending on subscription levels.

Figure 4.2: Approximate per article publisher cost shares: dual-mode subscription publishing (per cent)



Source: EI-ASPM model: Authors' analysis.

<sup>59</sup> This includes allowance for discounts to subscription agents, if any. Such discounts are typically small (e.g. 4% to 5%) and the trend is towards less use of subscription agents and more direct sales through Big Deals. Hence, they apply to fewer and fewer subscriptions. Consequently they are included in publisher costs/margins.

## Margins and taxes

Costs driven primarily by risk, capital costs and differential taxation treatment include:

- **Management and investment:** Following CEPA (2008) we allow a management and investment margin of 20% for management and investment. This accords with industry consultation. For the OA publishing model we allow a margin of 15% due to reduced overheads in relation to such things as pricing, proprietary hosting systems, legal and licensing, reduced investment as author-fees materialise immediately, etc.
- **Surplus/profit:** Operating margins are relatively high in scholarly publishing,<sup>60</sup> and we allow 20% for toll access publishing and for the OA publishing model we allow a margin of 15% due to lower risk and reduced cost of capital.
- **Taxes:** VAT on subscriptions applies to e-only journals in the UK while print journals are exempt, but as VAT is not a part of publisher costs it is not included as such.<sup>61</sup> However, any VAT paid on subscriptions is included in system costs as a part of acquisition costs, discussed below.

## Journal publisher costs: discussion and summary

Most of the reported publisher costings on which these estimates are based are derived from the print era and relate to the subscription publishing model. This has two important implications.

First, many analysts have suggested that e-only publishing could cost substantially less, but some of the savings have yet to be realised because of the continuation of print-based processes in which the electronic version is generated after the print version, rather than vice versa. As a result, estimating e-only costs from these sources is prone to understating the potential savings available through moving to an entirely e-only format throughout the publishers' process.

Second, being based on subscription models, a similar problem may arise in costing OA publishing if 'born-OA' costs less than subscription publishing minus the cost elements driven by subscriptions. On this latter point, however, it is worth noting that the costings presented herein triangulate well with reports of specialist OA journal publisher costs. For example, when the times reported by Hedlund *et al.* (2004) are translated to UK pounds using higher education full economic costing, their average cost per article for the OA publishers surveyed is around £1,690 compared with our estimates in the range of £1,525 to £1,830 – depending on format. Moreover, with author-fees charged converging at around USD 3,000 or £1,500 (at 2007 annual average exchange rates), our estimate of £1,525 per article for e-only OA publishing would seem reasonable given that it includes full commercial margins.

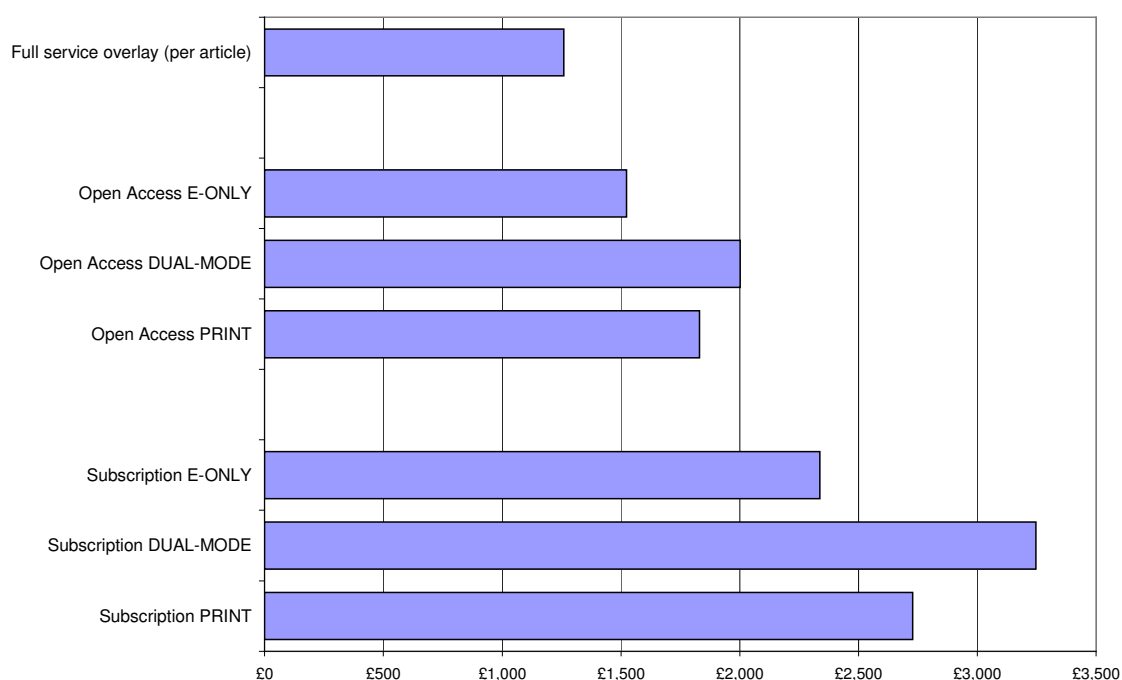
---

<sup>60</sup> CEPA (2008) allowed a relatively generous margin of 25%. Company financials show major commercial publisher operating margins ranging from around 10% (Wiley) to around 25% (Elsevier), although their STM journal publishing operations often report higher margins. Non-profit publisher operating margins are likely to be lower (perhaps 10% or less).

<sup>61</sup> VAT would be collected on the (domestic) provision of publisher services, including author-pays fees (*i.e.* publishing services) and overlay services – depending on the domicile of content producers and the VAT registration status of institutions.

Table 4.5 summarises the base case model costs in UK pounds circa 2007, which exclude the costs associated with external peer review and VAT. We estimate an average publisher cost of around £3,247 per article for dual-mode subscription publishing (excluding the costs associated with external peer review and VAT), £2,728 per article for print only and £2,337 per article for e-only subscription publishing. For e-only OA we estimate average per article costs at £1,524. Excluding the costs of printing and delivery we estimate the cost of dual-mode OA publishing at around £2,000, and £1,830 for print only OA.<sup>62</sup>

Figure 4.3: Estimated average publisher costs per article by format and model (GBP, circa 2007)



Note: These costs exclude the external costs of peer review and VAT. Overlay services include operating peer review management, editing, proofing and hosting, with commercial margins. Estimates for print and dual-mode OA publishing exclude print or subscriber related costs, assuming that the content is produced print ready and print is an add-on.

Source: EI-ASPM model: Authors' analysis.

We have included the implied 'publisher' costs of overlay services for completeness (*i.e.* elements of publisher activity that could provide value added overlay services to OA repositories). The same commercial management, investment and profit margins are applied.

<sup>62</sup> It is impossible to estimate the cost of printing and delivery in OA publishing as it depends on the number of copies involved and in the absence of subscriber counts that number cannot be known. Therefore estimates for print and dual-mode OA publishing exclude print or reader/subscriber related costs, assuming that the content is produced print ready and print is an add-on.

This shows, for example, that operating peer review management, editing and proofing as an overlay service would cost around £1,127 per article (excluding hosting).<sup>63</sup>

These estimates were derived entirely from the bottom up, but they triangulate well with simple top down checks. For example, CEPA (2008) citing Outsell Inc. suggested that around half of STM revenues are derived from scholarly journals, approximately £4.6 billion worldwide in 2007. Björk *et al.* (2008) estimated the total number of articles produced worldwide at around 1.35 million, while CEPA (2008) suggested 1.59 million. Simply dividing worldwide publisher journal revenue by the number of articles produced suggests per article publisher revenues of around £2,865 to £3,380, compared with our bottom up cost estimates of £2,923 based on current mixes of formats and models and £3,247 for dual-mode subscription publishing.<sup>64</sup>

**Table 4.5: Estimated average publisher costs per article by format and model (GBP, circa 2007)**

|  | <i>Lower Bound</i> | <i>Upper Bound</i> | <i>Estimate</i> |
|--|--------------------|--------------------|-----------------|
| <b>Subscription Journal Publishing</b>                           |                    |                    |                 |
| Per article costs PRINT  | 1,938              | 4,594              | 2,728           |
| Per article costs DUAL-MODE                                      | 2,184              | 5,480              | 3,247           |
| Per article costs E-ONLY   | 1,570              | 3,601              | 2,337           |
| <b>OA Journal Publishing</b>                                     |                    |                    |                 |
| Per article costs PRINT  | 1,481              | 2,582              | 1,831           |
| Per article costs DUAL-MODE                                      | 1,589              | 2,814              | 2,003           |
| Per article costs E-ONLY   | 1,193              | 2,122              | 1,524           |
| <b>OA Self-archiving<br/>(<i>Publisher overlay services</i>)</b> |                    |                    |                 |
| Peer review management as an overlay service                     | 334                | 721                | 455             |
| Editing and proofing as an overlay service                       | 589                | 854                | 673             |
| Hosting as an overlay service                                    | 77                 | 182                | 132             |
| <i>'Full service' overlay (per article)</i>                      | 1,001              | 1,756              | 1,260           |

Note: These costs exclude the external costs of peer review and VAT. Overlay services include operating peer review management, editing, proofing and hosting, with commercial margins. Estimates for print and dual-mode OA publishing exclude print or subscriber related costs, assuming that the content is produced print ready and print is an add-on.

Source: EI-ASPM model: Authors' analysis.

### 4.3.2 Books

Costs relating to research monograph publishing are less widely discussed in the literature, although there a number of sources on book publisher costs, management and pricing issues that

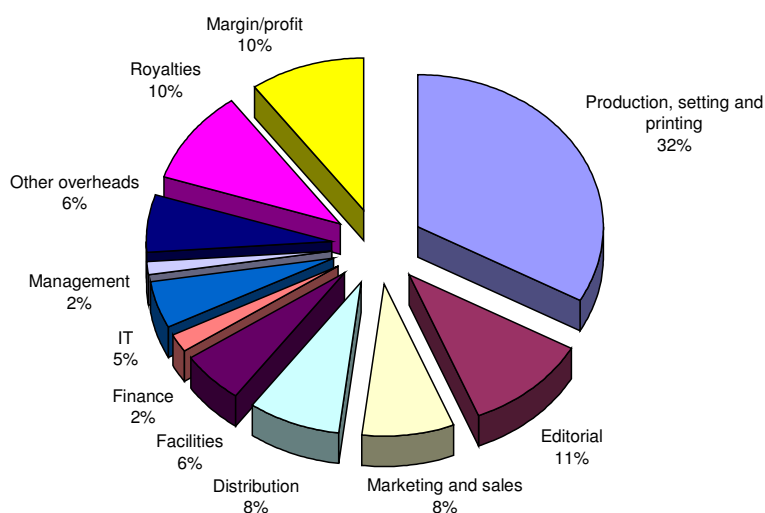
<sup>63</sup> Given the cost differences identified, the exclusion of VAT will somewhat reduce full cost differences between publishing models.

<sup>64</sup> The costings presented herein include an operating margin of 20%, based on reported margins.

provide a foundation (Altbach and Hoshino 1995; Wasserman 1997; Clark 2001, 2008; Watkinson 2001; Greco 2003; Kasdorf 2003; Thompson 2005; Greco and Wharton 2008; etc.).

It is clear that book publishing costs vary widely, even within scholarly monograph publishing – between soft and hard backs, production quality, print runs, sales and so on. Nevertheless, our review of the literature and industry consultation provides a platform for some approximate cost estimates. Again we present estimates by format and publishing model, even though toll access print publishing is still the norm for books, with e-only and OA publishing alternatives only now emerging. As such these estimates are largely hypothetical.

Figure 4.4: Approximate academic book publisher cost shares: print (per cent)



Note: Cost shares of estimated net sales revenue per title, print.  
Sources: Industry consultation and Clark (2001). EI-ASPM model: Authors' analysis.

Based on proportions derived from industry consultation and those reported in the literature, we estimate average research monograph publisher net sales revenue (NSR) at around £10,000 to £20,000 (average £15,750) per title in 2007 prices (excluding external peer review costs).<sup>65</sup> The following decomposition of those costs is based on proportions reported by a prominent UK academic book publisher and in such sources as Clarke (2001) and is necessarily approximate.<sup>66</sup>

<sup>65</sup> There are various ways to approach such estimates, with average cover price minus discount, times the number sold being indicative – e.g.  $NSR @ 15,750 = (45 - (45 \times 30\%)) \times 500$ .

<sup>66</sup> While similar, there are some differences between these proportions and those reported as typical among US University Presses by Greco and Wharton (2008).

### Box 4.6: Estimation assumptions: Publish scholarly works (Monographs)

| <b>Parameter</b>  | <b>Basis</b>                                     | <b>Value</b>             |
|---|--|--------------------------|
| Pages per title   | Watkinson (2001) and industry consultation       | 250 to 300, estimate 275 |
| Sales per title   | Watkinson (2001) and industry consultation       | 350 to 500, estimate 500 |
| Average prices  | Watkinson (2001), industry consultation and LISU | £40 to £50, estimate £45 |
| Publisher discounts (print)                                 | Industry consultation                            | 20% to 40%, estimate 30% |
| Peer reviewers per manuscript                               | Industry consultation                            | 2 perhaps 3, estimate 2  |
| E-only production, setting and printing (relative to print) | CEPA (2008), Waltham (2005)                      | 25%                      |
| E-only IT facilities (relative to print)                    | Authors' estimate                                | 200%                     |
| Toll access e-only facilities (relative to print)           | Authors' estimate                                | 50%                      |
| OA e-only facilities (relative to toll and print)           | Authors' estimate                                | 33%                      |
| OA rights management (relative to toll)                     | Authors' estimate                                | 20%                      |
| OA marketing and support costs (relative to toll)           | Authors' estimate                                | 33%                      |
| OA management and overhead costs (relative to toll print)   | Authors' estimate                                | 75%                      |

Source: Authors' analysis.

### Operational and processing costs

Operational and processing costs vary with monograph page lengths and formats, print runs and sales, and to a lesser extent with the level of internal and/or external peer and editorial review and the publisher's manuscript rejection rate. Consequently, the following suggested averages are no more than an approximate guide to the sort of costs involved.

**Editorial and review:** We estimate publishers' monograph editorial and review costs at around £1,730 per title. This excludes the costs associated with external reviewing activities, which we estimate at around £2,080 per monograph published.<sup>67</sup>

**Production, setting and printing:** We estimate production, setting and printing costs at around £5,200 per title for print publishing at average page lengths and formats, and £1,300 for e-only – based on the same cost proportions as print versus e-only journal publishing for these activities.

**Distribution (publisher):** For the toll access model, we estimate physical distribution costs at an average of around £1,260 per title, depending on print run and sales, and e-only distribution at the same because there are costs associated with toll e-book distribution that while different in nature may be similar in sum. For OA e-only book publishing, we substitute distribution with online hosting and estimate distribution costs per title at £200 – twice as much as OA e-only article hosting.

<sup>67</sup> External peer review of books is often paid in kind (*e.g.* book discounts) and occasionally in cash. These payments go to the reviewers and are typically less than full economic cost.

**Marketing and sales:** For toll access print publishing, we estimate marketing and sales costs at an average of around £1,260 per title, unchanged for e-only toll publishing and at one-third or £420 for e-only OA book publishing (*i.e.* marketing primarily to authors).

### Overhead costs

Attributing overhead costs to titles is necessarily vague, and typically based on simple averages of costs divided by the number of titles published in a given year.

**Management and finance:** We estimate management and finance costs at an average of around £550 per title for all formats and publishing models.

**Facilities:** We estimate facilities costs at an average of around £870 per title for toll access print publishing, at one-half or £430 for e-only toll publishing and at one-third or £290 for e-only OA publishing – with differences driven by different handling requirements.

**Information technology:** ICT costs also reflect format and publishing model, and we estimate average ICT costs of £790 per title for toll access print publishing and double for e-only toll and open access (*i.e.* e-book) publishing, £1,575.

**Other overhead costs:** In the absence of further information about the specific attribution of other overheads and costs, we estimate other overhead costs at an average of around £945 per title for both toll access formats and £710 per title for OA e-only.

### Margins and royalties

**Royalties:** Based on industry consultation we set author royalty payments at 10% of net sales revenue, or an average £1,575 per title for print toll access publishing. As a percentage, this equates to an average £1,132 for e-only toll access publishing. As they are a share of revenue, we assume no royalties apply to e-only OA publishing.

**Margin/profit:** Based on industry consultation we set the margin at 10% as well, or an average £1,575 per title for print toll access publishing, which as a percentage equates to £1,132 for e-only toll access publishing and £670 for e-only OA publishing.<sup>68</sup>

These average costs can be summed by format and publishing model, with toll access book publishing in print costs at an estimated average of £15,750 per title, toll access e-only publishing costs at an estimated £11,320 per title, and e-only OA publishing costs at £7,380.<sup>69</sup> These average costs are no more than approximations, but differences between the modes and models are indicative. Those difference are accentuated when distributor discounts are factored into the equation.

---

<sup>68</sup> To the extent that they can recoup distributor discounts through direct sales, toll access book publishers can increase their margins substantially. For example, recouping distributor discounts of 30% on a book that sells 500 copies at £45 each, would add £6,750 to the per title margin.

<sup>69</sup> Consultation with one university OA e-press revealed approximate per title costs (*i.e.* total costs divided by number of titles published during 2007) of around £7,200 (excluding hosting).

Table 4.6: Estimated average publisher costs per title by format and model (GBP, circa 2007)

|                                     | <i>Estimate</i> |
|-------------------------------------|-----------------|
| <b>Per monograph title</b>          |                 |
| Per monograph costs (Toll - PRINT)  | 15,750          |
| Per monograph costs (Toll - E-only) | 11,320          |
| Per monograph costs (OA - E-only)   | 7,380           |

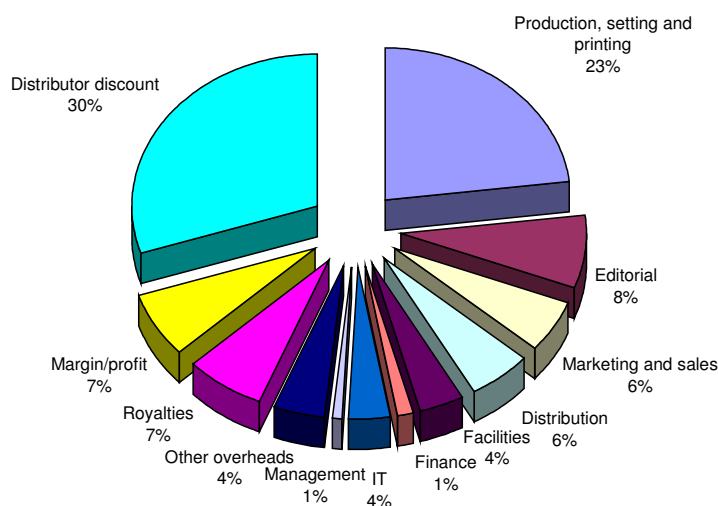
Note: These costs exclude the external costs of peer review and VAT. They also exclude possible recouping of distributors' discounts through direct sales.

Source: EI-ASPM model: Authors' analysis.

### Distribution of books

Academic book publisher discounts to distributors can be substantial, ranging in the region of 30% to 40%. These discounts should not simply be included in publisher costs, but rather separately identified as distribution or channel costs.

Figure 4.5: Approximate academic book publisher and distribution cost shares: with distributor discounts included, print (per cent)



Note: Cost shares of estimated Gross Sales Revenue per title, print.  
Sources: Industry consultation. EI-ASPM model: Authors' analysis.



For example, if a book sold 500 copies at £45 per copy, a 30% distributor's discount would be worth £13.50 per item or £6,750 per title. On the costs and parameters outlined above we estimate discounts ranging from £4,200 to £7,500 per title, with £6,750 the modelled estimate.<sup>70</sup>

If all books produced by UK-based researchers had been published toll access in 2007, the distributor discounts would have amounted to around £88 million nationally, of which £86 million would have related to higher education book outputs.

Adjusting publisher and distributor costs brings our estimated average costs per title to £22,500 for print, £14,716 for e-books and an unchanged £7,380 for OA e-books – substantially increasing differences between publishing models.

### 4.3.3 The current situation

Based on published estimates of the current mix of formats and publishing models reported by publishers worldwide, we can use the item costs outlined above to estimate the approximate total publisher costs of publishing UK scholarly output (*i.e.* multiplying the item costs of the current format and model mixes by the number of publications produced derived from adjusted ISI Web of Knowledge counts).

We estimate the publisher related costs of UK national research published output (excluding the non-cash costs of external peer review) at around £575 million in 2007, of which some £520 million related to higher education. Books (edited and authored) accounted for the largest shares nationally and in higher education, costing around £200 million. The publisher costs of UK authored journal articles published during 2007 amounted to around £335 million, of which some £287 million related to higher education.

---

<sup>70</sup> With many research libraries buying books from major academic publishers on approval plans (*i.e.* keep and pay, or return) and publishers increasingly offering direct online purchasing for one-off sales direct sales may be increasing. These may allow publishers to retain or re-coup discounts, effectively returning them to publisher margins and/or reducing book prices.

Table 4.7: Estimated publisher costs of UK research output (GBP, circa 2007)

| <i>Source &amp; type of publication</i>      | <i>Estimate</i>    |
|--|--------------------|
| <b>Higher Education (Published Outputs)</b>  | <b>517,300,000</b> |
| Journal articles                             | 287,500,000        |
| Conference papers                            | 2,700,000          |
| Books  | 157,100,000        |
| Edited books                                 | 44,300,000         |
| Chapters                                     | 21,200,000         |
| Other  | 4,600,000          |
| <b>National Research (Published Outputs)</b> | <b>573,900,000</b> |
| Journal articles                             | 334,400,000        |
| Conference papers                            | 5,100,000          |
| Books  | 162,000,000        |
| Edited books*                                | 44,300,000         |
| Chapters                                     | 23,600,000         |
| Other*                                       | 4,600,000          |
| <b>Book distribution</b>                     |                    |
| Total Higher Education authored and edited   | 86,310,000         |
| Total National authored and edited           | 88,390,000         |

Notes: Book publisher costs are based on research monographs costs, despite the fact that a small percentage of the books produced will be textbooks which have very different costs. Hence, the costs are no more than indicative. \* National total for edited books and other is higher education only as there is no separation of edited books and books categories and recording of other material possible outside higher education.

Source: EI-ASPM model: Authors' analysis.

#### 4.3.4 The publisher cost implications of alternative publishing models

Major areas of possible impact include the potential for more open access to reduce the time and costs involved for publishers in rights management, legal and licensing, pricing, marketing, negotiations and sales, distribution, and the operation of access control and authentication systems (See section 2.3.4 above).

#### 4.3.5 Cost savings and impacts

One of the keys to comparing the costs of alternative publishing models is to disentangle the cost impacts of format (*i.e.* print versus electronic) and model (*i.e.* toll versus open access). This is very difficult to do. Nevertheless, the costings outlined above provide a basis for estimates of the potential cost impacts of both formats and models.

## Journals

Table 4.8 presents detailed base case estimates for costs per article and for UK research outputs for each format and model, showing the publisher cost impacts of each – with format differences in toll access and model differences in e-only.

**Table 4.8: OA versus toll access journals: cost estimates by mode and model (GBP, circa 2007)**

|  | <i>Estimate</i> |
|--|-----------------|
| <b>Costs per article</b>                                 |                 |
| Current mix of formats and models                        | 2,920           |
| All print subscription                                   | 2,730           |
| All e-only subscription                                  | 2,340           |
| All e-only OA publishing                                 | 1,520           |
| <i>All e-only OA self-archiving and overlay services</i> | 1,130           |
| E-only impacts   | 390             |
| OA publishing impacts                                    | 810             |
| OA self-archiving and overlay impacts                    | 1,210           |
| OA publishing impact from current position               | 1,400           |
| <b>Costs per article published (Higher Education)</b>    |                 |
| Current mix of formats and models                        | 287,500,000     |
| All print subscription                                   | 268,400,000     |
| All e-only subscription                                  | 229,900,000     |
| All e-only OA publishing                                 | 149,900,000     |
| <i>All e-only OA self-archiving and overlay services</i> | 110,900,000     |
| E-only impacts   | 38,500,000      |
| OA publishing impacts                                    | 80,000,000      |
| OA publishing impact from current position               | 137,500,000     |
| <b>Costs per article published (National)</b>            |                 |
| Current mix of formats and models                        | 334,400,000     |
| All print subscription                                   | 312,200,000     |
| All e-only subscription                                  | 267,400,000     |
| All e-only OA publishing                                 | 174,400,000     |
| <i>All e-only OA self-archiving and overlay services</i> | 129,000,000     |
| E-only impacts   | 44,800,000      |
| OA publishing impacts                                    | 93,000,000      |
| OA publishing impact from current position               | 160,000,000     |

Note: These estimates were derived entirely from the bottom up, but they triangulate well with simple top down checks.

Source: EI-ASPM model: Authors' analysis.

It reveals that average per article cost savings of around £390 might be realised through a shift from print to e-only toll access publishing, and average per article cost savings of around £810 might be realised through a shift from toll to open access e-only publishing. Per article publisher cost savings of around £1,400 might be realised through a shift from the mix of formats and models current in 2007 to all OA publishing e-only. More speculatively, estimates suggest that a

shift to OA self-archiving with basic overlay services (*i.e.* peer review management, editing and proofing) might result in somewhat higher publisher cost savings than OA publishing.

Scaled to UK article publishing output, these cost savings would amount to an estimated average of around £45 million from a shift from print to e-only toll access publishing, and £93 million from a shift from toll to open access e-only publishing nationally (at 2007 prices and levels of publishing output). The savings from a shift from the mix of formats and models current in 2007 to all OA e-only are estimated to amount to an average of around £160 million.

For UK higher education article publishing output in 2007, these cost savings would amount to an estimated average of around £38 million from a shift from print to e-only toll access publishing, and £80 million from a shift from toll to open access e-only publishing. For higher education, the savings from a shift from the mix of formats and models current in 2007 to all OA e-only are estimated to amount to an average of around £138 million.

## Books

A similar calculation can be performed for scholarly monograph publisher costs, albeit with substantially less accuracy than is the case for journal publisher costs. Table 4.9 presents the same detailed base case estimates for costs per title and for UK research outputs for each format and model, and includes authored and edited books but excludes book chapters.<sup>71</sup>

It shows that estimated average per title cost savings of around £4,430 might be realised through a shift from print to e-only toll access publishing, and average per title cost savings of around £3,940 might be realised through a shift from toll to open access e-only publishing. Hence, per title publisher cost savings of around £8,370 might be realised through a shift from all print toll access to all OA e-only.

Scaled to UK scholarly monograph publishing output, these cost savings would amount to an estimated average of around £58 million from a shift from print to e-only toll access publishing, and £52 million from a shift from toll to open access e-only publishing nationally (at 2007 prices and levels of publishing output). Hence, the savings from a shift from all print toll access to all OA e-only are estimated to amount to an average of around £110 million.

For UK higher education scholarly monograph publishing output in 2007, these cost savings would amount to an estimated average of around £57 million from a shift from print to e-only toll access publishing, and £50 million from a shift from toll to open access e-only publishing. Hence, for higher education, the savings from a shift from all print toll access to all OA e-only are estimated to amount to an average of around £107 million.

---

<sup>71</sup> These costings are based on research monographs, but outputs will include textbooks which have very different costs. Hence, they are no more than indicative.

Table 4.9: OA versus toll access monographs: cost estimates by mode and model (GBP, circa 2007)

|   | <i>Estimate</i> |
|---|-----------------|
| <b>Costs per title</b>                              |                 |
| Current mix (assuming all print toll)               | 15,750          |
| All print toll access                               | 15,750          |
| All e-only toll access                              | 11,320          |
| All e-only OA                                       | 7,380           |
| E-only impacts                                      | 4,430           |
| OA impacts  | 3,940           |
| OA impact from current position                     | 8,370           |
| <b>Costs per title published (Higher Education)</b> |                 |
| Current mix of formats and models                   | 201,400,000     |
| All print toll access                               | 201,400,000     |
| All e-only toll access                              | 144,800,000     |
| All e-only OA                                       | 94,400,000      |
| E-only impacts                                      | 56,600,000      |
| OA impacts  | 50,400,000      |
| OA impact from current position                     | 107,000,000     |
| <b>Costs per title published (National)</b>         |                 |
| Current mix of formats and models                   | 206,200,000     |
| All print toll access                               | 206,200,000     |
| All e-only toll access                              | 148,200,000     |
| All e-only OA                                       | 96,600,000      |
| E-only impacts                                      | 58,000,000      |
| OA impacts  | 51,600,000      |
| OA impact from current position                     | 109,600,000     |

Note: Includes authored and edited books, but excludes book chapters. These costings are based on research monographs, but outputs will include textbooks which have very different costs. Hence, they are no more than indicative.

Source: EI-ASPM model: Authors' analysis.

Thus, proportionally greater publisher cost savings might be realised in the shift from print to electronic format for books than is the case for journals, while savings from a shift from toll to open access are likely to be proportionally greater for journals.

## Worldwide

Assuming that the UK accounts for around 8% of worldwide scholarly output, and the exact percentage depends on how international joint authorship is counted, these UK cost impacts can be multiplied to provide a very approximate estimate of worldwide impacts.

At the average cost estimates for 2007, cost savings for journals would amount to an estimated average of around £560 million worldwide from a shift from print to e-only toll access publishing, and £1.2 billion from a shift from toll to open access e-only publishing worldwide (at 2007 prices and levels of publishing output). The savings from a shift from the current mix

of formats and models to all OA e-only would amount to an average of around £2 billion – bearing in mind that publisher costs around the world will vary considerably.

#### Box 4.7: Scenario assumptions: Publish scholarly works

| <i>Parameter</i>   | <i>Basis</i>                          | <i>Value</i>              |
|--|---------------------------------------|---------------------------|
| UK share of worldwide scholarly publishing output (articles) | DIUS (2007), CEPA (2008), King (2004) | 6.6% to 9.4%, estimate 8% |
| Competition reduces publisher costs and margins              | Authors' estimate                     | 5% to 10%, estimate 5%    |

Source: Authors' analysis.

Too little is known about the UK share of worldwide scholarly monograph output to make a similar estimate for potential worldwide cost savings, but from the UK evidence one might expect those savings to be substantial.

#### 4.3.6 Competition impacts

A number of analysts have noted that OA publishing and self-archiving bring increasing competition for subscribers *and* authors and tend to put downward pressure on publisher costs and prices (Kaufman-Wills 2005; Bergstrom and Lavaty 2007).

##### **Scenario: competition puts downward pressure on costs and margins**

If increased competition did lead to downward pressure on costs and margins of even 5%, then considerable publisher cost savings could be made. For example, at the average costs noted above, it would reduce the publisher costs per article on the current mix of formats and models by around £145 per article and per monograph by around £790.

On annual UK national publishing output in 2007, this would represent a saving of around £10.3 million on books and £17 million on journals, of which higher education would account for £10 million and £14 million, respectively.

## 4.4 Facilitate dissemination, retrieval and preservation

The activities involved in facilitating dissemination, retrieval and preservation are outlined in Part I (See <http://www.cfses.com/EI-ASPM/SCLCM-V7/>).

There are a variety of actors involved in facilitating dissemination, retrieval and preservation and their activities are combined in different ways. The activities of publishers, intermediaries (*e.g.* aggregators, agents and distributors), research libraries and the various operators of repositories overlap, making it difficult to clearly identify some of the costs involved. Some of the activities and costs are included in the publisher costs outlined above. Of the remainder it is perhaps costs associated with research libraries and repositories that are of most interest and most relevance in trying to analyse the costs and budgetary implications of alternative scholarly publishing models.

#### 4.4.1 Research library costs

For UK research libraries, SCONUL provide detailed statistics on activities and costs for higher education, but there is little information available for research and special libraries outside the higher education sector.

For UK higher education the basic parameters are clear. In 2006-07, SCONUL libraries reported total expenditure of £597 million, of which £205 was spent on acquisitions – £113 million on serials and £92 million on non-serials items.

There are a number of limitations to the SCONUL statistics in terms of how things are classified and counted (*e.g.* the inclusion of some books in serials subscription packages rather than as e-books). Nevertheless, the implied average cost per serial title was £81 (perhaps around 70 pence per article), and the implied cost of non-serial acquisitions per item was £23. Around £56 million of the non-serial acquisitions expenditure was on “books and pamphlets”, with an implied per title acquisition cost of £18 for print materials and £3.46 for e-books.<sup>72</sup> Non-acquisition costs amounted to around £70 per item acquired.

Aside from acquisition costs, one of the major drivers of library costs is the format of acquisitions. For 2006-07, estimated UK HE library serials acquisitions by title were around 15% print, 10% dual-mode and 75% electronic, although the ratio of expenditures is rather different, at 29% print, 29% dual-mode and 42% electronic. E-books accounted for approximately 25% of the book titles acquired during 2006-07, but just 7% of book expenditure.<sup>73</sup>

#### Library journal handling costs

There have been a number of studies of library journal-related handling costs, of which Halliday and Oppenheim (1999), King *et al.* (2004) and Schonfeld *et al.* (2004) are among the most detailed. Based on the average time spent on various activities per title for print and electronic journals, and the average reported SCONUL library staff salaries, we estimate print subscription, e-only subscription and e-only OA journal processing and handling costs in UK research libraries circa 2007 at around £112 per title for print subscription access, £28 per title for electronic subscription access, and £20 per title for electronic OA journals per title (perhaps around 94 pence, 23 pence and 17 pence per article, respectively).<sup>74</sup>

---

<sup>72</sup> It is likely that dividing expenditure by acquisitions somewhat understates the average cost paid per print title as not all acquisitions are purchased (*e.g.* donations and bequests, library mergers, copyright deposit, etc.). The same calculation for e-books is fraught with difficulties as there are different forms of payment for platform access, annual subscription, outright purchase by title or package of titles, pay-per-view and combinations of these. Hence, little can be made of e-book expenditure per title.

<sup>73</sup> These acquisition costs include VAT where payable (*e.g.* on e-only formats).

<sup>74</sup> OA e-only journal handling expenditure could be considered discretionary, as user communities could discover and access the material independent of their research libraries. However, it is included to provide a basis for cost comparisons between publishing models.

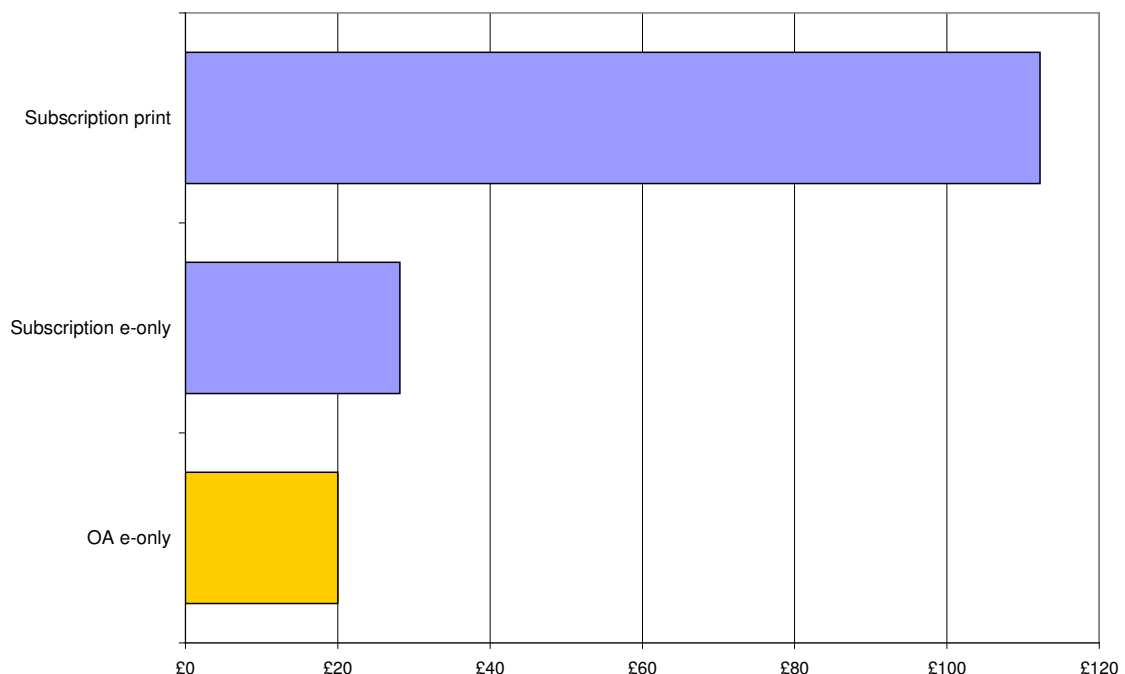
Table 4.10: Estimated journal related library activity costs per title (GBP, 2006-07)

| <i>Activity</i>         | <i>OA (e-only)</i> | <i>Electronic</i> | <i>Print</i> |
|-------------------------|--------------------|-------------------|--------------|
| Collection development  | ..                 | 2.77              | 4.82         |
| Negotiation & licensing | ..                 | 1.39              | 0.15         |
| Subscription processing | ..                 | 3.81              | 10.85        |
| Receipt & Check in      | ..                 | 0.14              | 16.27        |
| Routing                 | ..                 | ..                | 0.60         |
| Cataloguing             | 3.47               | 3.47              | 13.26        |
| Linking                 | 0.52               | 0.52              | 0.60         |
| Physical processing     | ..                 | 0.07              | 15.19        |
| Stacks maintenance      | ..                 | ..                | 8.89         |
| Circulation             | 1.39               | 1.39              | 16.27        |
| Reference               | 9.01               | 9.01              | 16.27        |
| User instruction        | 2.43               | 2.43              | 1.81         |
| Preservation            | 0.07               | 0.07              | 1.21         |
| Other                   | 3.12               | 3.12              | 6.03         |
| <b>Total</b>            | <b>20</b>          | <b>28</b>         | <b>112</b>   |

Note: Approximate activity times reported by Schonfeld *et al.* (2004) and King *et al.* (2004) converted to 2007 pounds based on average SCONUL library staff costs, with electronic staff costs 15% higher than print to reflect different skill levels (as per the studies mentioned).

Source: EI-ASPM model: Authors' analysis.

Figure 4.7: Estimated average per title library handling costs by format and model (GBP, 2006-07)



Note: Approximate activity times reported by Schonfeld *et al.* (2004) and King *et al.* (2004) converted to 2007 pounds based on average SCONUL library staff costs, with electronic staff costs 15% higher than print to reflect different skill levels.

Source: EI-ASPM model: Authors' analysis.



These costs include the on-costs and overheads experienced in UK higher education institutions, but do so at an average level and may therefore tend to understate differences between formats where print materials require buildings, floor space and shelving, which may be more costly than the electronic equipment and infrastructure required for electronic materials. Variation in local and national practices may also affect certain cost items, such as centralised consortial negotiation and purchasing versus individual institutional purchasing.

These costs can be scaled to library serials acquisitions to give an approximate estimate of current HE library journal-related handling costs, taking account of the format of those acquisitions (Table 4.11).<sup>75</sup> We estimate that electronic subscription journal related handling cost around £33 million during 2006-07 and print journal handling cost around £38 million – a total of around £71 million (approximately £50 per title). There is insufficient information to estimate OA journal handling costs, if any.

**Table 4.11: Estimated journal related SCONUL library activity costs (GBP, 2006-07)**

| <i>Activity</i>         | <i>Electronic</i> | <i>Print</i>      |
|-------------------------|-------------------|-------------------|
| Collection development  | 3,250,000         | 1,640,000         |
| Negotiation & licensing | 1,620,000         | 50,000            |
| Subscription processing | 4,470,000         | 3,690,000         |
| Receipt & Check-in      | 160,000           | 5,540,000         |
| Routing                 | ..                | 210,000           |
| Cataloguing             | 4,060,000         | 4,520,000         |
| Linking                 | 610,000           | 210,000           |
| Physical processing     | 80,000            | 5,170,000         |
| Stacks maintenance      | ..                | 3,030,000         |
| Circulation             | 1,620,000         | 5,540,000         |
| Reference               | 10,560,000        | 5,540,000         |
| User instruction        | 2,840,000         | 620,000           |
| Preservation            | 80,000            | 410,000           |
| Other                   | 3,660,000         | 2,050,000         |
| <b>Total</b>            | <b>33,030,000</b> | <b>38,220,000</b> |

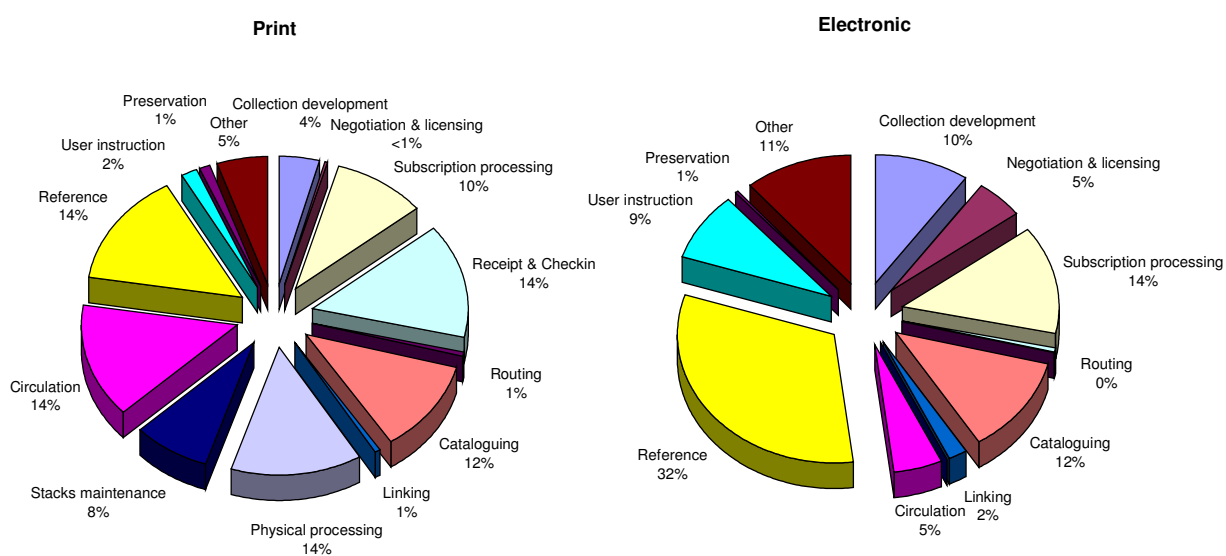
Note: Approximate activity times reported by Schonfeld *et al.* (2004) and King *et al.* (2004) converted to 2007 pounds based on average SCONUL library staff costs with electronic staff costs 15% higher than print to reflect different skill levels, and scaled to SCONUL library acquisitions.

Source: EI-ASPM model: Authors' analysis.

Indicatively, however, if all HE library serials acquisitions were of a single format, we estimate that handling costs would have been around £155 million during 2006-07 if they had all been print subscription, £39 million if all e-only subscription and £28 million if all e-only open access (*i.e.* Gold OA). This shows the importance of format and publishing model in research library handling costs – not forgetting that subscription cost differences between publishing models should be combined with these handling cost differences to examine the implications of alternative publishing models (see below).

<sup>75</sup> Although it has to be remembered that not all serials are journals, just as not all non-serials are books.

Figure 4.8: Estimated distribution of journal handling costs by activity (per cent)



Note: Approximate activity times reported by Schonfeld *et al.* (2004) and King *et al.* (2004).  
Source: EI-ASPM model: Authors' analysis.

### Library book handling costs

There are no comparable book handling analyses, but adjusting journal handling time per title to take account of there being no negotiation and licensing costs for books outside e-book collections, lower receipt and check-in costs per title and higher circulation costs, and triangulating with known HE library non-acquisition costs, provides a basis for some very approximate or 'ballpark' estimates.

These estimates are developed from HE library acquisitions of books and pamphlets in print and electronic formats, and exclude other non-serial items (*e.g.* databases, archives and manuscripts). Again there are limitations to SCONUL statistics (*e.g.* the inclusion of some books in serials subscription packages rather than as e-books) and some life-cycle cost differences between journals and books that are not taken into account due to insufficient information. Hence, these estimates are no more than first approximations.

Nevertheless, our estimations suggest that book handling costs in HE libraries in 2006-07 might have been around £90 per title for print, and £28 per title for electronic (including acquisition and negotiation costs). Handling costs for OA e-books, if any, might be around £20 per title.<sup>76</sup> At estimated acquisition levels and formats across HE libraries in 2006-07, that would have amounted to around £265 million for print items (*i.e.* books and pamphlets) and £30 million for e-books – a total of around £295 million, or £75 per title acquired.

<sup>76</sup> Again OA e-only handling expenditure could be considered discretionary, as user communities could discover and access the material independent of their research libraries, but it is included to provide a basis for cost comparisons between publishing models.

Indicatively, if all book titles acquired in 2006-07 had been of a single format and model, HE library handling costs may have been of the order of £360 million for all print toll access and £110 million for e-only toll access (perhaps £80 million for e-only OA).

### Subscription content access and user costs

SCONUL statistics provide a foundation for exploring subscription content access and use costs for research library acquisitions in UK higher education.

For example, total SCONUL serials acquisitions expenditure implies a per title cost of £81 in 2006-07, or around 68 pence per article, whereas electronic subscription expenditure implies a per title cost of £67, or around 56 pence per article (for e-only titles). The latter amounts to around £555 per academic staff or £35 per FTE users (*i.e.* staff and students), while the former amounts to around £665 per academic staff member or £51 per FTE user.

**Table 4.12: Estimated journal acquisition and handling costs in UK HE (GBP, 2006-07)**

|  | <i>Per title</i> | <i>Per article<br/>(Estimated)</i> |
|--|------------------|------------------------------------|
| <b>Subscription</b>                    |                  |                                    |
| Overall subscription acquisition costs | 81               | 0.68                               |
| Overall library handling costs         | 51               | 0.43                               |
| E-only subscription acquisition costs  | 67               | 0.56                               |
| E-only library handling costs          | 28               | 0.94                               |
| <b>OA Publishing</b>                   |                  |                                    |
| E-only subscription                    | ..               | ..                                 |
| E-only library handling costs          | 20               | 0.17                               |

Notes: Handling costs are based on activity times reported by Schonfeld *et al.* (2004) and King *et al.* (2004) converted to 2007 pounds based on average SCONUL library staff costs, with electronic staff costs 15% higher than print to reflect different skill levels.

Source: EI-ASPM model: Authors' analysis.

Data are far from complete, but SCONUL library electronic subscriptions appear to have received around 92 million full text download requests during 2006-07 and the average acquisition cost per download was reported to be 65 pence, with an average of 0.51 downloads implied per article. E-books were also widely used, with 4.4 million accesses recorded, 5.33 accesses per e-book, at an acquisition cost of 65 pence per access.

### Other library costs

Research libraries and users face a range of other access related costs. Many of these are difficult to isolate in detail, but in some cases data are available and/or there is sufficient evidence to support estimation.

**Inter-library loans:** During 2006-07, SCONUL libraries are estimated to have received around 674,000 ILL borrowing requests of which 598,000 (approximately 90%) were satisfied. An ILL expenditure by SCONUL libraries of £4.1 million was reported (around £6.90 per ILL).

The British Library fields many ILL requests, perhaps as many as 2 million in 2006-07, generating document delivery revenue of almost £12 million. The British Library currently charges £9.22 for an electronic ILL and £10.40 for a hardcopy mailed ILL.

**Licensing negotiations:** During 2006-07, SCONUL libraries estimated journal negotiation and licensing costs were £1.5 million and subscription processing costs £7.7 million, with the combined negotiation and subscription processing activities costing an estimated £9.2 million.

In 2004, the annual cost of the NESLi2 Journal Negotiations was reported to have been £255,000 and for every £1 of JISC funding the saving from NESLi agreements was reported to be at least £7.33 – suggesting costs avoided of some £1.9 million for what was covered by the NESLi negotiations.

**Access control and authentication:** We estimate that user support relating to electronic journals alone cost SCONUL libraries around £2.5 million, and one can imagine that a significant share of this related to access issues. Unfortunately, how significant a share is not known.

In 2004-05, Athens authentication for UK higher education alone is reported to have cost £619,225, £1,207 per institution or around 10 pence per authentication.

**Permissions and copyright fees:** Based on the time allocations cited by Halliday and Oppenheim (1999), we estimate the cost of copyright permissions sought by research libraries at around £14 per permission in 2007. Unfortunately we have no data on the number of permissions sought, and cannot estimate the total cost involved.

At £4.92 per FTE, UK higher education institutions may have paid something in the order of £9 million The Copyright Licensing Agency during 2007, which itself reported annual operating expenses approaching £6 million for 2007. This compares with the estimates of Maynard and Davies (2001) of around £5.6 million in copyright costs for higher and further education in the UK at that time.

#### 4.4.2 Repository costs

Due to the enormous range of scope, sophistication and coverage, repository costs vary greatly. Nevertheless, based on a ‘consensus’ costing from a range of sources (Swan 2008; Bailey 2006; Universities UK 2007; Houghton *et al.* 2006; etc.) we estimate costs for a publications-focused institutional repository in a UK higher education or public sector research institution to range from £45,000 to £275,000, or an average estimate of around £65,000 per year in 2007 prices – when establishment and upgrade costs are amortised over three years and added to ongoing operational costs. These direct costs often exclude the time spent by senior management in policy and advocacy activities, so to be conservative we adopt £100,000 per year as our estimate of publications-oriented institutional repository costs.

We have insufficient information to estimate the costs associated with publications-focused subject repository, data repositories or hybrid repositories – although one might expect the costs of publications-focused repositories of both kinds to be broadly similar and those of data repositories orders of magnitude greater (Beagrie *et al.* 2008). Industry consultation suggests

that the operational costs of major hybrid subject repositories may be up to £600,000 per annum (excluding the costs of self-archiving).

**Repository operational costs:** As of August 2008, there were 118 OA repositories reported by ROAR in the UK, of which 94 had the text string “ac.uk” in the URL – implying that they were higher education based. Hence, we estimate the annual operational costs of the existing OA repositories (including establishment and renewal costs) at around £11.8 million nationally, of which around £9.4 million related to higher education.

At these cost levels, if there was one institutional e-prints repository in each UK higher education institution the operational cost would be around £16.8 million per annum (for 168 repositories), and if the same ratio of higher education to other repositories was maintained the national operational costs would be around £21 million per annum (for 211 repositories).

**Self-archiving costs:** To these costs we must add the cost of deposit (self-archiving). If taken literally and deposit were done by researchers, we estimate the cost at around £9.35 per deposit (*i.e.* 10 minutes at average academic salaries including on-costs and overheads). At the current level of content, the deposit of all types of objects on OA repositories to date would have cost around £4.4 million in the UK nationally, of which £3.4 million would have been in higher education.

If all publications produced during 2007 had been self-archived (a single deposit), we estimate that it would have cost around £1.6 million in the UK nationally and £1.3 million in higher education. The self-archiving of all journal articles alone, would have cost around £1 million nationally and £920,000 in higher education, although self-archiving journal articles is likely to involve more than one posting (*e.g.* pre-print, final author and/or publisher versions). Hence these self-archiving costs are likely to be lower bound estimates.

**Table 4.13: Estimated OA self-archiving costs (GBP, circa 2007)**

|  | <i>Estimate</i> |
|--|-----------------|
| Cost per year per repository                                     | 100,000         |
| Operational costs of current reps per year (National)            | 11,800,000      |
| Operational costs of current reps per year (Higher Education)    | 9,400,000       |
| Cost of depositing per article                                   | 9.35            |
| Cost of posting counted publications (National)                  | 1,629,600       |
| Cost of posting counted publications per year (Higher Education) | 1,313,500       |
| Cost of posting journal articles (National)                      | 1,069,700       |
| Cost of posting journal articles (Higher Education)              | 919,400         |
| <b>National system of OA repositories:</b>                       |                 |
| Total cost of OARs per year (National)                           | 22,718,900      |
| Total cost of OARs per year if all HEIs had one                  | 18,113,500      |
| Implied total cost per object (National)                         | 13.94           |
| Implied total cost per object (Higher Education)                 | 13.79           |

Note: National system costs include the cost of a single deposit of all published outputs.

Source: EI-ASPM model: Authors' analysis.

**Total repository costs of a national system:** Adding the operational costs of a national system of institutional repositories and the self-archiving costs of all publications produced suggests that total OA repository costs (*i.e.* OA self-archiving costs) could amount to around £23 million per annum nationally, of which around £18 million would relate to higher education (at 2007 prices and publication levels).<sup>77</sup>

**Repository content access costs:** Given relatively low levels of self-archiving to date, implied OA repository content access costs per item (*i.e.* the cost of providing access) are likely to be relatively high. However, there is insufficient information about annual rates of deposit to form the basis for an estimate.

Nevertheless, it is possible to estimate the cost of a national system of repositories and OA self-archiving of all published outputs. We estimate that nationally, such a system of OA self-archiving might cost around £13.94 per object (£20.72 per article, if only articles were self-archived) if all published output were self-archived (at 2007 prices and levels of publishing output). If all higher education institutions had a single repository and all published output was self-archived (a single deposit), it would cost around £13.79 per object (£19.27 per article, if only articles were self-archived).

#### *4.4.3 The dissemination, retrieval and preservation facilitation cost implications of alternative publishing models*

As elsewhere, a key issue is to separate the cost impacts and implications of publishing formats and publishing models. This section focuses on the implications of both for HE library handling costs, exploring a number of plausible scenarios.

#### Library acquisition and handling costs

##### **Scenario: implied library journal handling cost savings from electronic and OA publishing**

As noted above, we estimate HE library per title serials handling costs at £112 per title for print subscriptions, £28 per title for e-only subscriptions and £20 title for e-only OA journals.<sup>78</sup> At those levels, HE library handling costs for serials subscriptions during 2006-07 would have been around £155 million had they been all print subscriptions and £39 million had they all been e-only subscriptions, with the current mix of formats implying handling costs of around £70 million. Equivalent e-only OA journal handling costs would have been around £28 million.

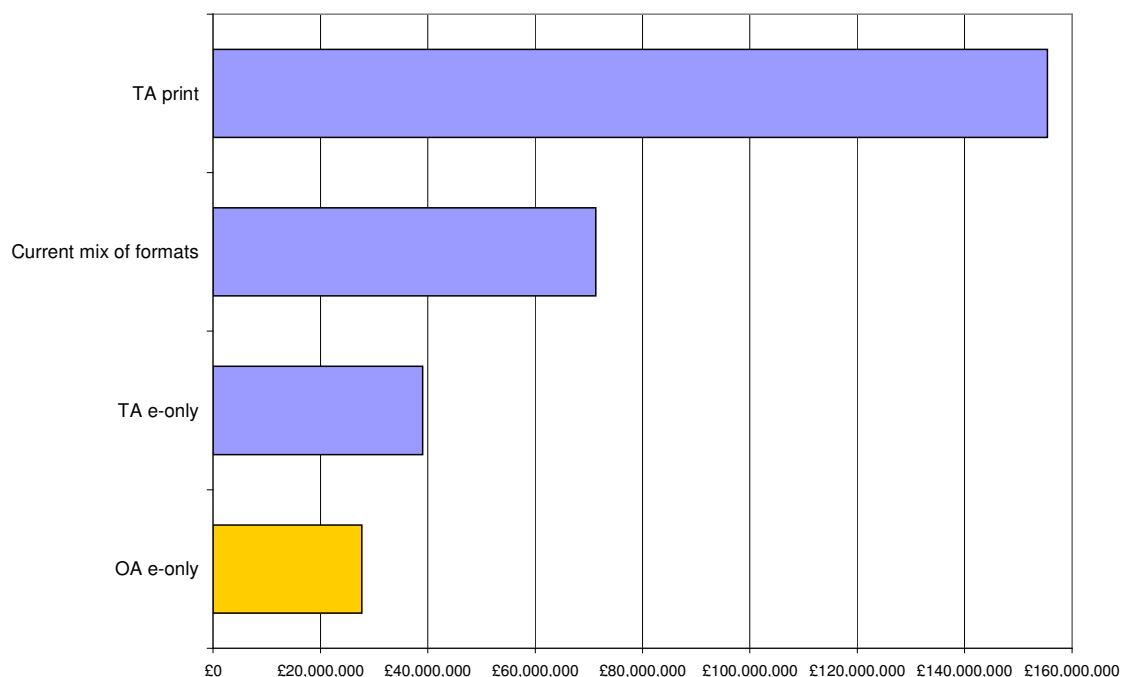
At 2006-07 subscription levels, the implied saving in HE library handling costs of OA e-only over print subscriptions would, therefore, have been of the order of £128 million and the saving of OA e-only over e-only subscriptions around £11 million. The implied handling costs saving of OA e-only over the current mix of subscription formats would have been around £45 million. To this, of course, one can add the library subscription acquisition costs of £113 million, making

<sup>77</sup> These costs exclude the production and possible publisher costs associated with the content, which are discussed elsewhere.

<sup>78</sup> As noted, this handling expenditure could be considered discretionary as user communities could discover and access the material independent of their research libraries. However, it is included to provide a foundation for comparison of publishing models.

a total estimated acquisition and handling cost saving from shifting from the current position to OA e-only for HE libraries of around £155 million.<sup>79</sup>

Figure 4.9: Estimated HE library journal handling costs by format and model (GBP, 2006-07)



Note: OA publishing handling expenditures could be considered discretionary, but are included to provide a foundation for comparison of publishing models.

Source: EI-ASPM model: Authors' analysis.

### Scenario: implied library book handling cost savings from electronic and OA publishing

Book handling cost estimates are much less robust, but it is clear that costs are substantial. As noted above, we estimate SCONUL library book handling costs at £90 per title for toll access print, and £28 per title for toll access e-books (perhaps £20 per title for OA e-books).<sup>80</sup> At those levels, SCONUL library book handling costs during 2006-07 would have been around £360 million had they been all print acquisitions and £112 million had they all been e-books, with the current mix of formats implying handling costs of around £295 million. Equivalent OA e-book handling costs might have been around £80 million.

The implied handling cost savings of OA e-books over the current mix of toll access formats would therefore have been around £216 million – perhaps £33 million from e-only toll to e-only OA. To this, of course, one can add the library acquisition costs of £56 million, making a total

<sup>79</sup> If the discretionary OA journal library handling expenditures were not made, the total annual saving to SCONUL libraries could have been around £180 million at 2007 prices and subscription levels.

<sup>80</sup> This handling expenditure could also be considered discretionary as user communities could discover and access the material independent of their research libraries. However, it is included to provide a foundation for comparison of publishing models.



estimated acquisition and handling cost saving from shifting from the current position to OA e-books for SCONUL libraries of around £270.

#### Box 4.8: UK Special Libraries

Relatively little is known about special libraries in the UK. Spiller *et al.* (1998) suggested that there may be up to 3,000 to 4,000 special libraries in the UK in the late 1990s (including government, legal, health, the voluntary sector, etc.) with serial subscriptions averaging around 220 titles per library. In 2000, LISU reported 2,436 special libraries in the UK with 237,000 journal subscriptions and almost 22.5 million books, or an average of 97 journal titles per library and 9,200 books. In mid 2008, the Directory of Special Libraries and Information Centres listed 1,650 special libraries in the UK.

It is likely that library closures and subscription cancellations are reducing these numbers over time. Nevertheless, multiplying the average number of special libraries reported (approximately 2,000) with the average subscriptions reported (approximately 100) suggests an average of 200,000 subscriptions.

Assuming similar library handling times and staff costs to those in SCONUL libraries, would suggest annual special library journal handling costs of £22 million if all subscriptions were print and £6 million if they were all electronic, and perhaps £4 million if they were all OA e-only. Hence, with around 15% of the number of SCONUL research library subscriptions, special library handling costs are likely to be around 15% of those in SCONUL libraries, as are the potential cost savings.

Source: Thanks are due to Claire Creaser and Donald King for these estimates (personal correspondence, November 2008), see also <http://www.lboro.ac.uk/departments/dils/lisu/list00/specilib00.html>.

#### Scenario: research library handling cost savings

Adding these handling cost saving together, implies that a shift from the current content acquisition mix to OA e-only could save SCONUL libraries £260 million per annum at 2007 prices and acquisition levels, and acquisition costs of £169 million (total £430 million – approximately £155 million from OA journals and £270 million from OA books).

#### Box 4.9: Scenario assumptions: Facilitate dissemination, retrieval and preservation

| <b>Parameter</b>   | <b>Basis</b>   | <b>Value</b>              |
|--|--|---------------------------|
| Share of UK HEIs subscribing to journal titles in which UK academic authors publish ( <i>i.e.</i> duplicate subscriptions) | Authors' estimate based on total, mean and median titles subscribed to by SCONUL libraries 2006-07 | 50% to 100%, estimate 75% |

Source: Authors' analysis.

#### OA publishing costs

Not all OA journals charge author-side fees, indeed perhaps less than half do so (Kaufman-Wills 2005). Nevertheless, for the purpose of exploring relative costs it is a convenient



shorthand to assume that these author-side, or perhaps more correctly producer-side, costs must be met from somewhere – be it authors, funders, institutions, foundations, donations or whatever.

There is an enormous range of author-fees, but based on a ‘straw poll’ of eight major OA publishers we find fees being charged ranging from around £800 to £1,600, with a consensus in the sample and literature of around £1,500.<sup>81</sup> It has also been noted that author fees are coalescing around USD 3,000 (around £1,500 at 2007 average annual exchange rates) (Kiley 2007). These reported fees triangulate well with the OA publisher cost estimates outlined above, which were derived independently from a bottom-up costing of publisher activities, in which OA e-only costs per article were estimated to average £1,448. At 2007 levels of article publishing by UK researchers, author-side fees (or producer-side fees) would have cost the UK around £170 million nationally for all journal articles published, of which around £150 million would have related to higher education.

It is very difficult to make meaningful comparisons between toll and open access, as they are very different things. Toll access seeks to provide UK subscribers with access to worldwide content (subject to affordability), whereas open access provides worldwide access to UK content. Consequently, the costs and benefits will be very different.

#### **Scenario: all journal articles are published using producer-side fees**

At the estimated costs outlined above, the comparable subscription costs of that number of articles within SCONUL library subscriptions for higher education in 2006-07 was around £67,000. Hence, if every journal article in the world had been Gold OA and SCONUL libraries had cancelled all serials subscriptions then, on average, higher education in the UK would have been around £35 million worse off during 2007 (*i.e.* would have had to meet an additional £35 million in producer-side fees).<sup>82</sup> If the UK had adopted OA producer-side fees based publishing unilaterally and UK HEIs had been able to cancel subscriptions to just those articles with current subscriptions without any change to the implied per article costs of the packages (which, of course, they could not), and assuming that on average 75% of universities subscribed to the titles in which UK academic authors publish, then UK higher education would have been around £140 million worse off.

As noted above, however, a change from the current mix of formats to OA e-only could, potentially, save SCONUL libraries £45 million in handling costs and, perhaps, £113 million in acquisition costs, making a total possible saving of around £156 million at 2007 prices and levels of publishing and subscription to offset the estimated higher education producer-side publishing costs of £148 million – a potential net saving to UK HE of around £8.8 million. Moreover, even this should be set against the possible overall system cost implications and,

---

<sup>81</sup> The publisher author fees sample included BioMed, PLoS, Hindawi (which may have a locational cost advantage), an ALPSP study of publishers’ charges, Springer Open Choice and ACS Author Choice, as well as two reports from the Wellcome Trust on the fees they are experiencing as funders of authors to cover those fees.

<sup>82</sup> Actual costs depend on the level of duplicate subscriptions across UK HEIs, although discounting for estimated duplicate subscriptions makes relatively little difference.

perhaps more importantly, the potential impact of enhanced access on economic and social returns to investment in research. We return to this topic below.

**Table 4.14: Potential cost implications of OA publishing for UK higher education (GBP, circa 2007)**

|   | <i>Estimate</i>     |
|---|---------------------|
| <i>Implied total cost (National)</i>                      | 171,700,000         |
| <b>Implied total cost for Higher Education</b>            | <b>147,500,000</b>  |
| Implied saving if the World adopted 'author-pays'         | <b>-34,800,000</b>  |
| Implied saving if UK HEIs adopted 'author-pays'           | <b>-139,100,000</b> |
| SCONUL Library savings (with subscription cancellations)  | 156,400,000         |
| Potential net saving for UK Higher Education Institutions | <b>8,800,000</b>    |

Note: All costs are expressed in 2007 UK pounds and, where necessary, have been converted to pounds using OECD published annual average exchange rates and adjusted to 2007 using the UK consumer price index published by the National Statistical Office.

Source: EI-ASPM model: Authors' analysis.

## OA self-archiving

As noted, we estimate that the OA self-archiving and repository costs of making an item accessible to the world might amount to around £13.79 per object in UK higher education and cost a total of around £18 million per annum for the operation of a single institutional repository in each UK HEI accepting and containing a single deposit of all published outputs (at 2007 prices and level of publishing output). A national system of repositories, including those in higher education, might cost around £23 million.

It is difficult to imagine how a UK or worldwide system of repositories might affect the operational activities of research libraries, as they may be a means of dis-intermediation or may change but leave intact the role of research libraries. Nevertheless, it is possible to explore the cost implications of some scenarios.

### Scenario: Worldwide OA self-archiving

In an all OA self-archiving world in which research libraries handle the same volume of article and monograph content, but treated it as OA e-only content, UK HE repository costs of £10-20 million might be offset by SCONUL library handling savings of around £44 million for journals alone from current mixes, and perhaps £260 million if all publications were self-archived on institutional repositories. If research libraries played no role in self-archived content access, the savings would be £71 million and £295 million, respectively.

Library content acquisition costs could also be avoided, amounting to £113 million for serials and £56 million for books (*i.e.* a total of £169 million) across SCONUL libraries in 2006-07. However, if acquisition costs cover publisher costs and something close to publisher copies are self-archived then these publisher costs cannot be avoided (see discussion in the previous section).

As discussed, in an overlay services or overlay journals model, we estimate the average costs of key components of possible overlay as follows:

- Peer review management as an overlay services, £455 per article;
- Editing and proofing as an overlay service, £673 per article; and
- Hosting as an overlay service, £132 per article.

Ignoring hosting, these review and production services overlays might amount to an average of around £1,127 per article (including commercial margins). As noted above, taking account of the current mix of formats and publishing models we estimate the average per article publisher cost to be £2,923 circa 2007, suggesting that an OA self-archiving model with overlay services might cost significantly less than the current system.<sup>83</sup>

## 4.5 System cost comparisons

In the preceding sections we have presented a range of costs and potential cost savings relating to the various scholarly publishing models. The task of this section is to bring these together as system costs and savings in order to compare the system-wide cost implications of alternative publishing models and as a foundation for an exploration of the implications for the flow of funds around the system.

### 4.5.1 System cost comparisons

The scholarly communication system model outlined in Part I involves five major elements: fund research and research communication; perform research and communicate the results; publish scientific and scholarly works; facilitate dissemination, retrieval and preservation; and study publications and apply the knowledge. Alternative publishing models combine these activities in slightly different ways (Table 4.15).

Table 4.15: Activities along the value chain by publishing model

| <b>Publishing model</b>  | <b>Fund</b><br><i>Allocate and evaluate</i> | <b>Perform</b><br><i>Write and review</i> | <b>Publish</b><br><i>Produce</i> | <b>Disseminate</b><br><i>Make available</i> | <b>Study</b><br><i>Discover and access</i> |
|--------------------------|---|---|----------------------------------|---|--|
| <b>Toll access</b>       | Review, grant & evaluate                    | Produce & review                          | Select, publish & distribute     | Library handling                            | User access                                |
| <b>OA publishing</b>     | Review, grant & evaluate                    | Produce & review                          | Select & publish                 | Library handling                            | User access                                |
| <b>OA self-archiving</b> | Review, grant & evaluate                    | Produce & review                          | Overlay services                 | Repository & self-archive                   | User access                                |

Source: Authors' analysis.

<sup>83</sup> There is insufficient information to cost handling and hosting related savings from OA book publishing.

As noted, it is very difficult to make meaningful comparisons between toll and open access. Toll access seeks to provide UK subscribers with access to worldwide content (to the limits of the subscriptions), whereas open access provides worldwide access to UK content. These are very different things.

## Costs and cost differences

One approach is to compare the costs associated with producing, publishing and providing access to UK and/or UK higher education research outputs in each of the publishing models. Table 4.16 summarises the estimated average costs relating to key elements of the value chain per article and per monograph produced in UK higher education for each of the major models for scholarly publishing. It explores the costs of producing and providing access to UK higher education output per item and system wide, based on the level of publishing output in 2007.<sup>84</sup> The totals are intended to highlight differences between models and should not be taken as system costs without also taking account of the double-counting implicit in the full economic costing (*i.e.* including overheads) of researcher activities in institutions that, for example, contain research libraries. Similarly, costs relate to the outputs of each activity area, such that the costs of writing and reviewing are per manuscript written and reviewed, whereas publisher costs are per manuscript published.<sup>85</sup>

Combining the estimated average costs for the production and distribution of journal articles, per article, for each of the publishing models we find that:

- Per article costs in UK higher education circa 2007 were £8,296 for the toll access subscription publishing model, £7,483 for the OA publishing (*i.e.* producer-side pays) model, and £7,115 for the OA self-archiving with overlay services model – assuming that all are e-only format.
- Per monograph costs in UK higher education circa 2007 were £80,194 for the toll access subscription publishing model, £72,850 for OA publishing, and £72,201 for the necessarily somewhat speculative OA self-archiving with overlay services model – again assuming that all are e-only format and including edited and authored books only.

Indicatively, these per item costs are multiplied by UK higher education research output of articles and books (*i.e.* authored monographs and edited books) in 2007 to give a sense of system-wide costs and cost differences. Presented in millions of pounds in Table 4.16, these show that:

- Article production and distribution costs in UK higher education alone would have amounted to around £815 million if all 2007 outputs had been toll access e-only, £735 million if all had been OA publishing e-only and £700 million if all had been OA self-archived with overlay services (*i.e.* review and production).

---

<sup>84</sup> There is insufficient data to do this for the UK at the national level.

<sup>85</sup> For example, estimated external peer review costs per article reviewed are £631 compared with £1,388 per article published (which includes the cost of reviewing those rejected and re-submitted).

- Monograph production and distribution costs for authored and edited books produced in UK higher education alone would have amounted to £1,025 million if all 2007 outputs had been toll access e-only, £930 million if all had been OA publishing e-only and £925 million if all had been OA self-archived with overlay services (*i.e.* review and production).<sup>86</sup>

Table 4.16: Estimated UK Higher Education costs by publishing model per item (GBP, circa 2007)

|                          | <i>Journal:<br/>Per article</i> |                          |                              | <i>Book:<br/>Per title</i> |                          |                              |
|--------------------------|---------------------------------|--------------------------|------------------------------|----------------------------|--------------------------|------------------------------|
|                          | <i>Toll<br/>Access</i>          | <i>OA<br/>Publishing</i> | <i>OA<br/>Self-archiving</i> | <i>Toll<br/>Access</i>     | <i>OA<br/>Publishing</i> | <i>OA<br/>Self-archiving</i> |
| <i>FUND</i>              | ..                              | ..                       | ..                           | ..                         | ..                       | ..                           |
| <i>PERFORM</i>           |                                 |                          |                              |                            |                          |                              |
| Write                    | 5,328                           | 5,328                    | 5,328                        | 63,935                     | 63,935                   | 63,935                       |
| Review                   | 631                             | 631                      | 631                          | 1,514                      | 1,514                    | 1,514                        |
| <i>PUBLISH</i>           |                                 |                          |                              |                            |                          |                              |
| Publish e-only           | 2,337                           | 1,524                    | 1,127                        | 11,320                     | 7,380                    | 6,703                        |
| Distribute               | ..                              | ..                       | ..                           | 3,396                      | ..                       | ..                           |
| <i>DISSEMINATE</i>       |                                 |                          |                              |                            |                          |                              |
| Handle e-only            | 0.23                            | 0.17                     | 0.17                         | 28                         | 20                       | 20                           |
| IR operation             | ..                              | ..                       | 19                           | ..                         | ..                       | 19                           |
| Deposit                  | ..                              | ..                       | 9.35                         | ..                         | ..                       | 9.35                         |
| <i>USE</i>               | ..                              | ..                       | ..                           | ..                         | ..                       | ..                           |
| <b>Total</b>             | <b>8,296</b>                    | <b>7,483</b>             | <b>7,115</b>                 | <b>80,194</b>              | <b>72,850</b>            | <b>72,201</b>                |
| <b>UK HE (mil)</b>       | <b>816</b>                      | <b>736</b>               | <b>700</b>                   | <b>1,025</b>               | <b>932</b>               | <b>923</b>                   |
| <i>UK National (mil)</i> | <i>949</i>                      | <i>856</i>               | <i>814</i>                   | <i>1,050</i>               | <i>954</i>               | <i>945</i>                   |

Note: Includes e-only average estimated costs for each publishing model, and excludes toll access acquisition costs to avoid double counting (*i.e.* assuming that acquisition costs recoup publisher and distribution costs). VAT is also excluded. The costs of writing and reviewing are per manuscript written and reviewed, whereas other costs are per manuscript published and disseminated. The OA self-archiving with overlay services models are necessarily rather speculative, especially for books.

Source: EI-ASPM model: Authors' analysis.

Hence, on average estimated costs, a shift from all toll access e-only to OA e-only publishing for all journal articles produced in UK higher education during 2007 would have directly saved around £80 million, and for authored and edited books around £94 million. A shift from all toll access e-only to OA self-archiving e-only with overlay services for all journal articles produced in UK higher education during 2007 would have saved around £116 million (an additional £36 million), and for authored and edited books around £102 million (an additional £8 million).<sup>87</sup>

<sup>86</sup> The costs of writing and reviewing are per manuscript written and reviewed, whereas other costs are per manuscript published and disseminated. Hence, they do not reflect full system costs, but this does not effect cost differences.

<sup>87</sup> All excluding VAT.

Indicatively, at the national level, a shift from all toll access e-only to OA e-only publishing for all journal articles produced in the UK during 2007 would have saved around £93 million, and for authored and edited books around £96 million; and a shift from all toll access e-only to OA self-archiving e-only with overlay services for all journal articles produced in the UK during 2007 would have saved around £135 million (an additional £42 million), and for authored and edited books around £105 million (an additional £8.5 million).

### Cost savings

In addition to production cost differences there are also potential cost savings, not just in production and distribution, but also in handling, research use and funding. Some of these potential savings and impacts have been noted above (Table 4.17).

#### *Books and journals*

**Fund Research:** Savings in internal evaluation of proposals, evaluation of impacts and reporting, and in lower cost of lobbying, of around £2.2 million. Additional returns to R&D of around £49 million per annum from the various scenarios explored, including:

- Funder savings spent on R&D;
- Improved quality of peer review and better evaluation metrics lead to better allocations and raise returns to R&D; and
- Increased visibility leads to increased R&D allocations, and thereby to increased impacts.

Sum of savings and returns, £51 million per annum at 2007 prices and levels of activity.

**Perform Research:** Savings and returns of around £230 million per annum nationally at 2007 prices and levels of activity, of which around £180 million from higher education, from the scenarios explored, including:

- Reduced search and discovery time through enhanced discoverability and greater access, and less use of proprietary silo access systems;
- Less time spent on seeking and obtaining permissions to use (copyright and licensing);
- Less time spent on checking in peer review through greater access, in turn making for better quality review; and
- Less time spent on writing and preparation through greater access making reference checking etc. easier.

**Publish research:** Savings relating to publishing are captured in the publisher cost differences between the publishing models outlined above. Wherein, for journals, e-only OA publishing publisher costs are estimated to be an average of £813 per article less than e-only toll access publishing (with OA self-archiving overlay services costing an estimated average of £1,210 less), and for monographs £3,940 less per title (£7,336 including distributor costs).

At 2007 levels of research publication, publisher cost savings for shifting from toll to OA e-only publishing would amount to around £145 million nationally and £130 million for higher education outputs (with OA self-archiving savings from overlay services of around £190 million nationally and £169 million for higher education outputs).

**Table 4.17: Estimated UK savings by publishing model: Journals and books (GBP millions, circa 2007)**

|               | <i>National</i> |            |             | <i>Higher Ed.</i> |            |             | <i>Additional returns</i> |            |             |
|---------------|-----------------|------------|-------------|-------------------|------------|-------------|---------------------------|------------|-------------|
|               | <i>Toll</i>     | <i>OAP</i> | <i>OASA</i> | <i>Toll</i>       | <i>OAP</i> | <i>OASA</i> | <i>Toll</i>               | <i>OAP</i> | <i>OASA</i> |
| FUND          | ..              | 2.2        | 2.2         | ..                | 2.2        | 2.2         | ..                        | 49         | 49          |
| PERFORM       | ..              | 190        | 190         | ..                | 139        | 139         | ..                        | 38         | 38          |
| PUBLISH       | ..              | 145        | 190         | ..                | 130        | 169         | ..                        | ..         | ..          |
| DISSEMINATE   |                 |            |             |                   |            |             |                           |            |             |
| Handling*     | ..              | 44         | 44          | ..                | 44         | 44          | ..                        | ..         | ..          |
| Acquisition   | ..              | ..         | ..          | ..                | ..         | ..          | ..                        | ..         | ..          |
| USE           | ..              | ..         | ..          | ..                | ..         | ..          | ..                        | ..         | ..          |
| Partial Total | ..              | 380        | 426         | ..                | 315        | 354         | ..                        | 87         | 87          |

Note: Includes e-only estimated cost savings for each publishing model, and excludes acquisition costs. In OA self-archiving for books all e-only publisher costs are included to reflect the operation of e-presses rather than overlay services. Additional returns are excluded from calculations to avoid possible double counting in the impacts of accessibility and efficiency on returns to R&D. \*National handling cost savings are those relating to SCONUL libraries only and include handling of all library acquisitions.

Source: EI-ASPM model: Authors' analysis.

**Facilitate dissemination:** Savings relating to facilitating dissemination, retrieval and preservation are largely captured in the research library handling cost differences between the publishing models outlined above. Wherein, for books and journals, e-only OA handling costs are estimated to be around £44 million less than e-only toll access handling in SCONUL libraries for their entire acquisitions (*i.e.* including non-UK outputs).

There are also significant library-related savings to be made in such areas as access and authentication systems costs, permissions and copyright fees through a shift to OA publishing and/or self-archiving with overlay services. However, due to limited information, these have not been included.

**Study and apply:** Savings relating to studying and applying are captured, in part, in those outlined under perform research (above). There is insufficient information to support a detailed analysis of costs and potential cost savings beyond research. However, with strong readership beyond research and among practitioners in a number of fields, one would expect these savings to be substantial.



## Journals

Table 4.18 presents these estimated savings as they relate to journal publishing only, and shows that OA publishing of journal articles alone would save £106 million in research activity costs nationally, of which £73 million would accrue in higher education. Publisher cost savings of around £93 million would be possible from a shift to OA publishing nationally (£138 million from OA self-archiving with overlay services), and £80 million from a shift to OA publishing higher education articles (£119 million from OA self-archiving with overlay services). SCONUL library article handling costs might be reduced by £11 million from a shift to OA publishing. Hence, as a partial total, a shift to OA publishing for UK research outputs might save £213 million nationally (£166 million in higher education), and a shift to self-archiving with overlay services £258 million nationally (£206 million in higher education).

**Table 4.18: Estimated UK savings by publishing model: Journals only (GBP millions, circa 2007)**

|               | <i>National</i> |            |             | <i>Higher Ed.</i> |            |             | <i>Additional returns</i> |            |             |
|---------------|-----------------|------------|-------------|-------------------|------------|-------------|---------------------------|------------|-------------|
|               | <i>Toll</i>     | <i>OAP</i> | <i>OASA</i> | <i>Toll</i>       | <i>OAP</i> | <i>OASA</i> | <i>Toll</i>               | <i>OAP</i> | <i>OASA</i> |
| FUND          | ..              | 2.2        | 2.2         | ..                | 2.2        | 2.2         | ..                        | 49         | 49          |
| PERFORM       | ..              | 106        | 106         | ..                | 73         | 73          | ..                        | 0.4        | 0.4         |
| PUBLISH       | ..              | 93         | 138         | ..                | 80         | 119         | ..                        | ..         | ..          |
| DISSEMINATE   |                 |            |             |                   |            |             |                           |            |             |
| Handling*     | ..              | 11         | 11          | ..                | 11         | 11          | ..                        | ..         | ..          |
| Acquisition   | ..              | ..         | ..          | ..                | ..         | ..          | ..                        | ..         | ..          |
| USE           | ..              | ..         | ..          | ..                | ..         | ..          | ..                        | ..         | ..          |
| Partial Total | ..              | 213        | 258         | ..                | 166        | 206         | ..                        | 49         | 49          |

Note: Includes e-only estimated cost savings for each publishing model, and excludes acquisition costs. Additional returns exclude the impacts of accessibility and efficiency on returns to R&D. \* National handling cost savings are those relating to SCONUL libraries only and include handling of all library acquisitions. Source: EI-ASPM model: Authors' analysis.

These potential savings offset the costs associated with more open access:

- **OA Publishing** – the estimated cost of author/producer side fees for OA publishing articles at £172 million per annum nationally (£148 million in higher education) comparing to estimated savings of £213 million nationally (£166 million in higher education); and
- **OA Self-archiving** – the estimated cost of OA self-archiving journal articles produced with overlay services at around £22 million per annum nationally (£18 in higher education) comparing with system savings of £258 million nationally (£206 million in higher education).



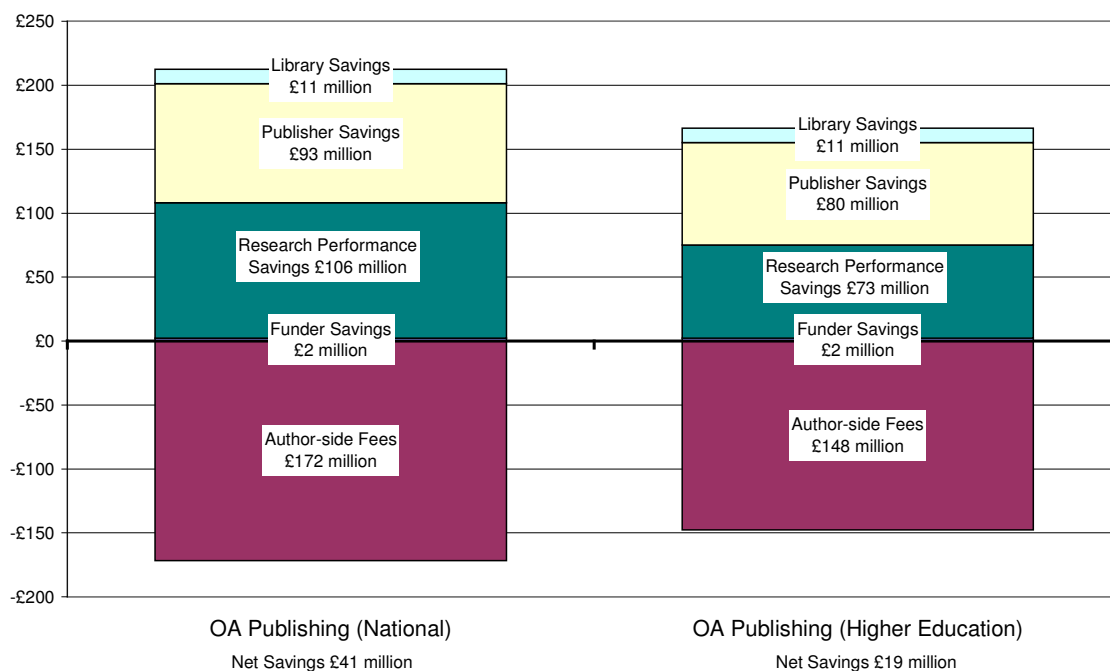
Both assuming e-only formats in all cases.

Hence, independent of any increases in returns to R&D spending accruing from enhanced accessibility and efficiency (see below), circa 2007:

- **OA publishing** journal article output might have saved £41 million nationally (£19 million in higher education); and
- **OA self-archiving** that output with overlay services might have saved £236 million nationally (£188 million in higher education) (Figure 4.10).

Of course, these savings include the handling and use savings derived from both UK produced and non-UK research outputs, along with those relating to the publishing of UK-produced outputs.

Figure 4.10: Estimated annual costs and cost savings: OA publishing (GBP millions, 2007)



Note: Includes e-only estimated cost savings for each publishing model, and excludes acquisition costs. Research performance savings exclude the impacts of accessibility and efficiency on returns to R&D. \* National handling cost savings are those relating to SCONUL libraries only and include handling of all library acquisitions.

Source: EI-ASPM model: Authors' analysis.

### 4.5.2 The flow of funds

The possible impacts of alternative models for scholarly publishing on the flow of funds around the system were discussed in Part I, the task of this section is to explore how material those flows might be.

## Fund research

Changes in funding flows within research funding activities would be likely to revolve around:

- The use of a small percentage of grants funding to meet publishing fees (*e.g.* author-pays fees) and the implied marginal reduction of research funds, etc.;
- Possible reduced costs of research (*e.g.* reduced institutional overhead costs) *if* toll access costs fall (independently and/or through substitution), or researchers' search, discovery and access costs fall, etc.; and
- Possible increased funding coming in as enhanced access to the results of past research makes the funding agency more visible to the wider community and better able to articulate a value-proposition and lobby for funds. This would also apply to research organisation and contract research funds obtained directly from a funder.

It seems that the direct costs of funding agencies may not change much as a result of alternative publishing models, but there is likely to be an impact on the implied effective level of research funding – primarily through the diversion of research funds into author-side fees. Noting that only around half of all OA journals actually charge author fees but that support for OA publishing would nevertheless be coming from the producer side, we estimate that had all UK authored journal articles been published in an entirely producer-pays OA publishing model in 2007 it would have cost around £170 million nationally, of which around £150 million would have been from higher education. The impact of this is explored in the modelled scenarios (below).

## Perform research

In addition to possible costs and cost savings, impacts on funding flows within research activities would be likely to revolve around possible differences in the use of researcher time and funding (*e.g.* in applying for and obtaining permissions versus self-archiving to a subject or institutional repository, etc.). From the perspective of universities and research institutions, research library acquisition and handling cost savings can also be factored in.

On modelled estimates, system-wide savings and impacts alone are sufficient to cover the estimated producer-side costs of OA publishing and/or self-archiving. That is to say that the system cost savings would be likely to outweigh the costs of OA publishing, such that the diversion of research funds to support OA publishing at estimated costs would produce a net benefit.

Because research intensive institutions are both major producers and users of scholarly publications research and library cost savings will counter additional producer-side costs. Nevertheless, research intensive institutions will pay relatively more in a producer-pays system, and it would be preferable to cover the direct costs of producer-side OA publishing fees from competitive and block grants funding. This might be scaled to outputs in the previous year, and would be likely to cost of the order of £75 million to £150 million per annum to publish all UK higher education journal article output in OA journals.

## Publish research

Savings relating to publishing are captured in the publisher cost differences between the publishing models. Clearly, reduced costs would result in reduced revenue flows from research and research users to publishers, although these reductions may well be offset by revenue gains from selling value-added services to a larger number of readers and alternative revenue streams.

## Facilitate dissemination

Savings relating to facilitating dissemination, retrieval and preservation are largely captured in the research library acquisition and handling cost differences between the publishing models. There are also significant library-related savings to be made in such areas as operating and supporting access and authentication systems, permissions and copyright fees through a shift to OA publishing and/or self-archiving with overlay services.

It is difficult to say exactly how OA publications will be treated by research libraries and what role libraries will play in dissemination and preservation in these alternative publishing models. Nevertheless, we suggest that research libraries will continue to play a key role in providing access to OA journals and have costed library handling activities accordingly. With little evidence to date that OA self-archiving leads to subscription cancellations acquisition cost savings have not been included. However, should they arise in the future, there would be potential for significant additional savings.

## Study and apply

Costs, savings and funding flows relating to studying and applying have not been explored beyond those relating to research use of research outputs, and these are included in 'perform research' (above). However, with strong readership beyond research and among practitioners in a number of fields, one would expect these savings to be substantial.

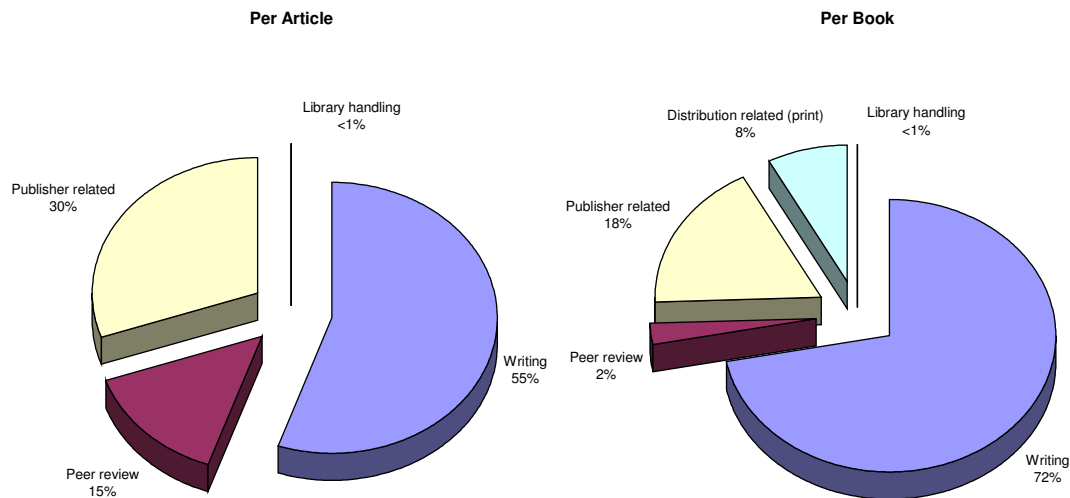
### *4.5.3 Costs of activities, objects and functions*

The matrix approach to costing lying behind the activity costs outlined above enables the presentation of activity costs in various forms, including costs for actors, objects and functions. This section looks at some examples, but it is by no means exhaustive of the matrix costing possibilities.

## Object costs

Combining activity costs to estimate object costs, we find that journal articles cost an estimated average of around £9,600 to produce in the UK circa 2007, of which around £5,300 related to the direct cost of writing (excluding other input research activities), £2,900 to publisher costs and £1,400 to external peer review costs (per article published). Publisher costs amount to an estimated 30% of total article production costs (Table 4.19).

Figure 4.11: Estimated per item object cost shares (per cent)



Note: Writing costs include those items that are not published while all other costs are per item published in the current mix of formats and models.  
 Source: EI-ASPM Model: Authors' analysis.

Table 4.19: Estimated per item object costs (GBP, circa 2007)

|  | <i>Estimate</i> |
|--|-----------------|
| <b>Cost per journal article</b>                    |                 |
| Writing  | 5,300           |
| Peer review (per published)                        | 1,400           |
| Publisher related                                  | 2,900           |
| Library acquisition                                | 0.68            |
| Library handling                                   | 0.43            |
| <i>Per article production</i>                      | 9,600           |
| Publisher share of production costs                | 31%             |
| <b>Cost per research monograph (title)</b>         |                 |
| Writing  | 63,900          |
| Peer review (per published)                        | 2,100           |
| Publisher related                                  | 15,800          |
| Distribution related (print)                       | 6,800           |
| Library acquisition (books and pamphlets per item) | 14              |
| Library handling                                   | 74              |
| <i>Per monograph production</i>                    | 88,600          |
| Publisher/Distributor share of production costs    | 25%             |

Note: Writing costs include those items that are not published while all other costs are per item published in the current mix of formats and models. Acquisition costs are excluded from the totals to avoid double counting.  
 Source: EI-ASPM model: Authors' analysis.

We estimate that research monographs (authored and edited books) cost an average of around £88,600 to produce in the UK circa 2007, of which around £63,900 related to the direct cost of writing (excluding other input research activities), £15,800 to publisher costs and an estimated £6,800 to distribution costs (assuming toll access print format), and £2,100 to external peer review costs (per title published). Publisher and distributor costs amount to an estimated 25% of total monograph production costs.

### Function costs

Similarly, activity costs can be combined into costs for specific functions, such as peer review costs and the functions of quality control and certification.<sup>88</sup>

The activity cost estimates outlined above include both internal publisher peer review related costs and external, largely non-cash, peer review costs.

- Per article published these amount to an estimated £344 and £1,388, respectively, or a total of £1,732 circa 2007.
- Per monograph published (*i.e.* authored and edited books) these costs are estimated at £1,733 per title for publisher editorial activities and £2,082 for external peer review, or a total of £3,815.

---

<sup>88</sup> A number of publisher activities relating to the proofing, checking and editing of manuscripts might also be included in the function of quality control, but have been excluded from this example for the sake of simplicity.

## 5 Quantifying benefits

As outlined in Part I our approach to exploring and quantifying costs, impacts and benefits is twofold. First, a detailed ‘bottom up’ costing which provides a foundation for the estimation of cost savings and for the development of scenarios exploring impacts (see above). Second, a ‘top down’ modelling of impacts on returns to R&D through further development and application of the modified Solow-Swan model outlined in Houghton *et al.* (2006) and Houghton and Sheehan (2006), which introduced *accessibility* and *efficiency* into the standard model, as negative variables, in order to explore the impact of increasing accessibility and efficiency on returns to R&D expenditure. Such an approach combines the principal methods that have been used to explore the impacts of R&D (*i.e.* macro econometric studies and case studies).

### 5.1 Modelling and estimating the impacts

In this section we introduce a modified Solow-Swan model and use it to estimate the potential impacts of alternative scholarly publishing models.

#### 5.1.1 An outline of the model

The task of fully exploring the impacts of enhanced access is substantial, but it is possible to gain some sense of the scale of potential impacts by developing a modified Solow-Swan model, introducing ‘*accessibility*’ and ‘*efficiency*’ parameters into calculating the returns to R&D.

#### Returns to R&D in a simple Solow-Swan model

In the basic Solow-Swan model, the key elements are a production function:

$$(1) \quad Y = A^\eta K^\beta L^\alpha$$

where  $A$  is an index of technology,  $K$  is the capital stock and  $L$  is the supply of labour, with both  $K$  and  $L$  are taken to be fully employed by virtue of the competitive markets assumption, and an accumulation equation:

$$(2) \quad \dot{K} = sY - \delta K,$$

where  $\dot{K}$  is the net investment or the change in the net capital stock, equal to gross investment less depreciation, and  $\delta$  is a constant depreciation rate. Substituting (1) into (2) gives

$$(3) \quad \dot{K} = sA^\eta K^\beta L^\alpha - \delta K.$$

From (3) it is possible to determine the conditions for steady state growth in the capital stock.

Re-arranging, taking logarithms, differentiating with respect to time and imposing the condition that for steady state growth:

$$d/dt(\ln \dot{K}/K) = 0$$

gives:

$$(4) \quad \dot{K}/K = \frac{\eta}{1-\beta} \dot{A}/A + \frac{\alpha}{1-\beta} \dot{L}/L$$

where  $\dot{K}/K = \dot{C}/C = \dot{Y}/Y$ , is the single constant steady state rate of growth of capital stock, consumption and output, respectively.

The main features of the Solow-Swan model are apparent from equation (4). Firstly, if technology and labour supply are fixed, the steady state growth rate is zero. That is, there is no endogenous growth in the model, growth being driven in the steady state by change in the exogenous variables. Secondly, if one of technology and population show positive growth then the steady state growth rate of the economy is proportional to the growth rate in that variable; if both rates are positive the economy's growth rate is a weighted average of the two. Thirdly, the steady state growth rate does not depend on either the level of savings or of investment in the economy. An economy that continuously saves and invests 20% of national income will have a higher level of output than one investing 5%, but it will not have a higher steady state growth rate. Thus the broad economic message of the Solow-Swan model is that steady growth is possible in a purely competitive world, provided that there is growth in either population or technology, or both.

### Contributions to growth and total factor productivity

Solow (1957) further developed this model in a way that provided the foundations for subsequent 'growth accounting'. Starting with total differentiation of the production function (1), and substituting for the partial derivatives of Y from (1) with respect to each of its arguments, yields:

$$(5) \quad \dot{Y}/Y = \eta \dot{A}/A + \beta \dot{K}/K + \alpha \dot{L}/L.$$

Equation (5) can then be used in two main ways in the empirical study of growth.

Given that in the competitive model capital and labour are paid their marginal products and assuming constant returns to scale,  $\beta$  and  $\alpha$  can be estimated from the relative shares of capital and labour. A variant of (5) with those weights can then be used to estimate the relative contribution of capital, labour, technology and other factors to growth. Solow made pioneering estimates in 1957, the results of which he later described as "startling" (Solow 1987), and these have been much refined and amplified by Denison (1985) and others. Solow found that 7/8<sup>th</sup> of the growth in real output per worker in the US economy between 1909 and 1949 was due to "technical change in the broadest sense" and only 1/8<sup>th</sup> to capital formation. Denison's 1985 estimates covered the US economy for the period 1929 to 1982. Of the growth in real business output of 3.1% per annum over that period, he found that the increase in labour input with constant educational qualifications accounted for about 25% and capital input for 12%. Most of the remainder is accounted for by technological progress and by the increased human capital of the work-force. What was "startling" about these results was the relatively minor contribution to output growth arising from the increase in the traditional factors of production, capital and labour.

The other related use of equation (5) is to estimate the "Solow residual", or total factor productivity. This is defined as the difference between output growth and the weighted sum of

the growth rates of factor inputs (K and L), using constant return to scale weights. That is, total factor productivity growth (TFP) is given by:

$$(6) \quad \text{TFP} = \dot{Y}/Y - \beta \dot{K}/K - \alpha \dot{L}/L,$$

where  $\beta = 1 - \alpha$ , and  $\beta$  and  $\alpha$  are derived from the shares of capital and labour in total income.

Total factor productivity is thus the growth in output not accounted for, on these assumptions, by the growth in capital and labour inputs. This method is now used very widely around the world in measuring productivity. This recent use has confirmed the broad Solow-Denison findings, in that for most modern economies total factor productivity growth is significantly more important than expansion of inputs in explaining total output growth. However, it must be remembered that the method rests on the assumptions embedded in the Solow model and that, as a consequence, the finding that the larger proportion of growth is to be explained by an exogenous “technical change in the broadest sense” constitutes something of an admission of defeat for economic analysis.

### Estimating the rate of return to R&D

While there are recognised limitations to the traditional growth model approach, this basic framework has been widely used in estimating the rate of return to R&D. The standard approach to estimating returns to R&D is to divide the technology variable A in (1) into two components, a stock of R&D knowledge variable R and a variable Z that represents a matrix of other factors affecting productivity growth. The production function then becomes:

$$(7) \quad Y = K^\alpha L^\beta R^\gamma Z^\eta,$$

and the counterpart of equation (5) becomes:

$$(8) \quad \dot{Y}/Y = \alpha \dot{K}/K + \beta \dot{L}/L + \gamma \dot{R}/R + \eta \dot{Z}/Z.$$

That is, the rate of growth of the R&D knowledge stock (*i.e.* accumulated R&D expenditure or R&D capital) contributes to output growth as a factor of production, with elasticity  $\gamma$ . The rate of return to knowledge ( $\partial y/\partial R$ ) is that continuing average per cent increment in output resulting from a one per cent increase in the knowledge stock. This can be readily derived from the elasticity  $\gamma$  by

$$(9) \quad \partial y/\partial R = \gamma \cdot (Y/R).$$

The normal approach to creating a measure of the stock of R&D knowledge, for a given industry or for the economy as a whole, is to use the perpetual inventory method to create the knowledge stock from the flows of R&D, using the relationship:

$$(10) \quad R_t = (1 - \delta) R_{t-1} + R\&D_{t-1},$$

where  $\delta$  is the rate of obsolescence of the knowledge stock. This method also requires some starting estimates ( $R_0$ ) of the knowledge stock, and estimates can be sensitive to that assumption.



Then the capital stock at time  $t$  is given by:

$$(11) \quad R_t = (1 - \delta)^t R_0 + \sum_{i=0}^{t-1} (1 - \delta)^i R\&D_{t-i}$$

Given a series for  $R$  and for the variables  $Z$ , it is then possible to estimate  $\gamma$  by either of the two methods noted above: estimate equation (8) with the parameters  $\alpha \dots \eta$  unconstrained, or obtain estimates of the parameters  $\alpha$  and  $\beta$  (constrained to be equal to one) from the factor shares of capital and labour, calculate TFP by a variant of (7) and regress  $R$  and  $Z$  on TFP to obtain  $\gamma$ .

### Incorporating the efficiency of research and accessibility of knowledge

This standard approach makes some key simplifying assumptions. Here we note three in particular. It is assumed that:

- All R&D generates knowledge that is useful in economic or social terms (*efficiency of R&D*);
- All knowledge is equally accessible to all entities that could make productive use of it (*accessibility of knowledge*); and
- All types of knowledge are equally substitutable across firms and uses (*substitutability*).

A good deal of work has been done to address the fact that the substitutability assumption is not realistic, as particular types of knowledge are often specialised to particular industries and applications. Much less has been done on the other two assumptions, which are our focus.

We define an ‘*accessibility*’ parameter  $\epsilon$  as the proportion of the R&D knowledge stock that is accessible to those who could use it productively, and an ‘*efficiency*’ of R&D parameter  $\phi$  as the proportion of R&D spending that generates useful knowledge. Then starting with a given stock of useful knowledge  $R^*_0$  at the start of period zero, useful knowledge at the start of period 1 will be given by:

$$(12) \quad R^*_1 = (1 - \delta) R^*_0 + \phi R\&D_0,$$

where the contribution of R&D in period zero to the knowledge stock is reduced by the parameter  $\phi$  to allow for unproductive R&D. This means that the stock of useful knowledge at period  $t$  is given by:

$$(13) \quad R^*_t = (1 - \delta)^t R^*_0 + \phi \sum_{i=0}^{t-1} (1 - \delta)^i R\&D_{t-i}$$

If the period over which knowledge is accumulated is long, so that  $(1 - \delta)^t R^*_0$  is small relative to  $R^*_t$ , then  $R^*_t$  can be approximated by  $\phi R$ . However, only a proportion of useful knowledge may be accessible, so that accessible useful knowledge at period  $t$  is  $\epsilon R^*_t$ , and hence approximately  $\epsilon \phi R_t$ , where  $R_t$  is the stock of knowledge as calculated under the standard methods.

Using this approximation and noting that it is accessible useful knowledge that is the correct factor in the production function, (6) becomes:

$$(14) \quad Y = K^\alpha L^\beta (\phi\epsilon R)^\gamma Z^\eta$$

If  $\phi$  and  $\epsilon$  are independent functions of time, then the results of estimating a linearised version of (14) that excludes them will be misleading. However, if we assume that these parameters reflect institutional structures for research and research commercialisation in a given country, and can hence be taken as fixed (and as less than or equal to one), then the standard results stand, but need to be reinterpreted. Again using  $R$  as the stock of knowledge calculated by the standard method (which assumes  $\phi = \epsilon = 1$ ) and  $R^*$  as the corresponding accessible stock of useful knowledge, then  $R = R^*/\phi\epsilon$ , and the rate of return to useful and accessible knowledge becomes:

$$(15) \quad \partial y/\partial R^* = \gamma \cdot (Y/R^*) = \gamma/\phi\epsilon \cdot (Y/R) = \gamma \cdot (Y/R) \cdot 1/\phi\epsilon.$$

Thus, if  $\phi$  and/or  $\epsilon$  are less than one, the rate of return to  $R^*$  is greater than that to  $R$  by the factor  $1/\phi\epsilon$ . This does not imply that the measured rate of return to  $R$  is biased, because  $R^* = \phi\epsilon R$ .

Assume now that there is a one-off increase in the value of  $\phi$  and  $\epsilon$ , from the constant values of  $\phi_0$  and  $\epsilon_0$  to new values of  $(1 + \delta_\phi)\phi_0$  and  $(1 + \delta_\epsilon)\epsilon_0$ , respectively. Then the rate of return to  $R^*$ , that is:

$$(16) \quad \partial y/\partial R^* = \gamma \cdot (Y/R) \cdot (1/\phi_0\epsilon_0)$$

is fixed, but the return to  $R$  will increase:

$$(17) \quad \begin{aligned} \partial y/\partial R &= \gamma \cdot (Y/R) = \phi_1\epsilon_1 \partial y/\partial R^* = \gamma \cdot (Y/R) \cdot (\phi_1\epsilon_1/\phi_0\epsilon_0) \\ &= \gamma \cdot (Y/R) \cdot (1 + \delta_\phi) \cdot (1 + \delta_\epsilon)\epsilon_0. \end{aligned}$$

It follows from (17) that, because the increase in efficiency and accessibility leads to a higher value of  $R^*$  for a given level of  $R$ , the rate of return to  $R$  will increase by the compound rate of increase of the percentage changes in  $\phi$  and  $\epsilon$ .

The basic result of the foregoing is that, if ‘*accessibility*’ and ‘*efficiency*’ are constant over the estimation period, but then show a one-off increase (*e.g.* because of a move to open access), then, to a close approximation, the return to R&D will increase by the same percentage increase as that in the accessibility and efficiency parameters.

### Some methodological notes on the model

While the model specification follows an established literature on the estimation of returns to R&D (*e.g.* Griliches 1986; Industry Commission 1995; etc.), there are a number of conceptual difficulties that need to be considered in applying this methodology to estimating the returns to knowledge generated by scholarly publications.

The first is that the measure of R&D used in the model is expenditure on R&D. This includes many activities that are broader than the creation of the stock of knowledge, arising from the writing and publication of scholarly journals, reports, etc., which is the focus of this study. As noted, in their review of the literature Martin and Tang (2007) identify seven ‘channels’ through

which the benefits of research flow into the economy. While one of these is an increase in the stock of knowledge, others include an increase in the supply of skilled graduates, the enhancement of problem solving capacity, new scientific instrumentation, development of networks and the creation of new firms. Some of these channels reflect increases in codified knowledge that is associated with the stock of knowledge and which some argue has increased relative to tacit knowledge (David and Foray 1995; Arora *et al.* 2001).

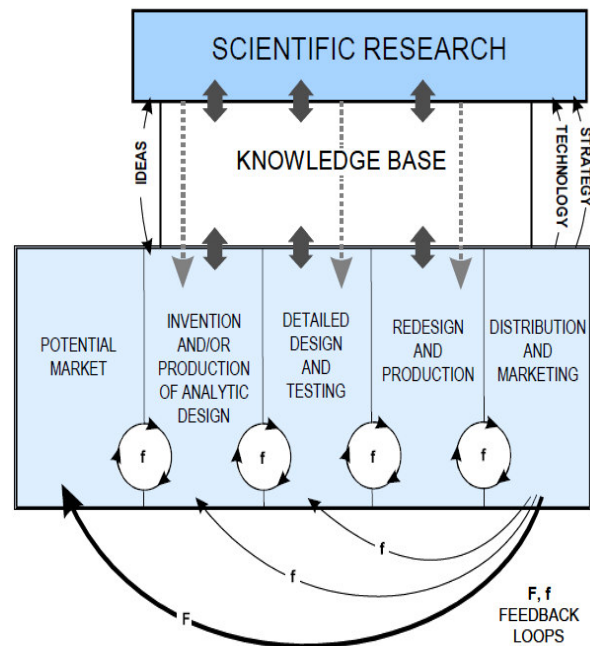
However, it is not sufficient to simply add to the total stock of codified knowledge. Other channels, such as the enhancement of problem solving capacity, reflect increases in tacit knowledge. The training of skilled graduates in basic research is an important part of the R&D function as is their use of tacit knowledge to find and interpret specialised knowledge to solve problems as part of the innovation process.

Even so, the PACE report (Arundel *et al.* 1995), quoted by Martin *et al.* (1996), lists publications as the most important ‘source and method for learning about public research’, with 58.4% of respondents rating it as important – above informal contacts (51.6%), hiring (44.4%) and conferences (43.9%). Amongst the research outputs of importance to industry, ‘specialised knowledge’ is rated as the most important to industry with 55.7%, rating it as important, over other outputs of public research, such as instrumentation (35.2%) and prototypes (19.4%). General knowledge from basic research was rated as important by 32.2%, reflecting the importance of tacit knowledge in the research output equation (Martin *et al.* 1996).

The second and related issue is the complexity of the innovation process itself. The production function form of the returns to R&D equation proposed herein suggests a simple linear (science push) model of innovation, in which R&D is simply another factor of production. However, it is widely acknowledged that this fails to capture the complex feedback loops of the process, as suggested by the Kline and Rosenberg (1986) chain link model, which at least conceptually captures this complexity. It suggests that, in addition to the creation of new ideas and designs from research and their conversion into commercially available technologies, successful innovation depends on feedback from a myriad of actors in the innovation system, including customers, marketing departments, suppliers, etc. Figure 5.1 shows the role of scientific research in the creation of the knowledge base and its interaction with a value chain incorporating design, production and marketing.

These two factors, the multiple mechanisms through which research impacts on innovation and the complexity of the innovation process itself, make it difficult to ascribe the results of research to a particular innovation. This ‘attribution problem’ has resulted in some estimates of returns to R&D being upwardly biased because of the failure to properly match streams of research costs to streams of outputs (Alston and Pardy 2001). Various approaches have been adopted to deal with this attribution problem, including introducing control variables for non-research factors into the equations used to estimate returns to R&D (Alston and Pardy 2001). Another is to selectively identify the influence of the stock of knowledge (Adams 1990, Verspagen 2004) by substituting measures of the stock of publications for broader measures of R&D, such as expenditure, in the returns to R&D equation.

Figure 5.1: Chain Link model of commercial innovation



Source: DEST (Department of Education, Science and Training) (2003) *Mapping Australian Science and Innovation: Main Report*, Canberra, p114. Based on Kline and Rosenberg (1986).

Mansfield (1991, 1998) attempted to measure the returns to R&D for those innovations that are directly related to academic research. From a survey of R&D executives, he found that around 10% of sales of new products and processes would not have occurred (without substantial delay) in the absence of recent academic research. He estimated that the social rate of return from this research was 28% and that the time lag between an academic research finding and the first commercial introduction of the product and processes was an average of around 7 years.

This suggests that where broader approaches to measuring the returns to R&D have been used, such as in this study, some care is required to properly attribute the general returns to R&D to the development of the stock of knowledge represented by scholarly publications. For a single country such as the UK, this requires not only consideration of the extent to which scholarly communications relates to the returns to R&D from Higher Education R&D expenditure in the UK, but also how spillovers occur between countries or regions (Jaffe 1989).

In this study the approach is to estimate the proportion of total R&D activity devoted to the production and use of scholarly publications in terms of researchers' time and its impact on returns to R&D in the UK as being indicated by economic studies of localisation of returns supplemented by evidence from downloads and citations.

### 5.1.2 Estimating the impacts

To operationalise the model we need to estimate values for the 'accessibility' and 'efficiency' parameters, as well as a number of other parameters.

## Accessibility: rationale for the range to be modelled

**Accessibility** is defined as the proportion of the stock of knowledge generated by R&D that is accessible to those who could use it productively. As there are imposed and practical barriers to access, the '*accessibility*' parameter is less than one – a friction variable. The key issue is what impact might alternative models for scholarly publishing have on accessibility?

This can be unpacked to the following questions:

- What proportion of the research stock of knowledge is in scholarly publications in general, and journals in particular?
- What proportion of the research stock of knowledge is likely or potentially available to alternative scholarly publication models?
- What measures are there of the potential impacts of the alternative models for scholarly publication on accessibility?

We deal with each of these in turn.

### **What proportion of the research stock of knowledge is in scholarly publications in general, and journals in particular?**

Under the assumptions of the standard approach the research stock of knowledge is the output of the stream of expenditure on R&D, allowing for rates of accumulation and obsolescence. That is to say, that whatever researchers do with the research funding they employ contributes to the research stock of knowledge. Hence, a useful proxy for the proportion of the research stock of knowledge that is scholarly publications is the proportion of researchers' time spent reading and writing publications, and, perhaps, peer reviewing and acting in editorial capacities relating to those publications.

The data collected for estimating costs include the average time spent by researchers in industry and in universities on these tasks. Based on Tenopir and King (2000) and the many subsequent tracking studies we estimate that researchers spend an average of around 90 to 100 hours writing journal articles and perhaps 1,000 to 1,200 hours writing research monographs and editing books. Both reading and writing habits vary between industry and university based researchers, but reading times for journal articles range from around 75 to 150 hours per year – with times for other published materials scaled to page lengths and relative complexity. Overall, on average, these estimations suggest that active researchers spend around 20% to 25% of their time reading and writing journal articles, and perhaps 30% to 40% on reading and writing all materials they use in the context of their research (*i.e.* including journal articles, books, reports, conference papers, trade and technical literature, etc.). These estimates do not include time spent on scholarly publishing related editorial and peer review activities.

Hence, on the basis of time spent, as a conservative estimate we could say that 20% of the stock of research knowledge relates to journals and perhaps up to a further 20% to research monographs, edited books, reports and other publications.

### **What proportion of the research stock of knowledge is likely or potentially available to alternative scholarly publication models?**

Noting again that the research stock of knowledge is the output of the stream of expenditure on R&D, the answer to this question lies in the sectoral shares of R&D expenditure. Much of the discussion about open access and alternative models for scholarly publishing revolves around access to publicly funded research – referring more, we suspect, to the sector of execution than sector of funding. Clearly much less private sector research (by sector of execution) finds its way into journals, although there is no reason to suppose that that which does would be inherently less suitable for OA publishing or self-archiving. Nevertheless, to be conservative, we limit analysis to publicly funded research in general and to higher education expenditure on research (HERD) in particular.

### **What measures are there of the potential impacts of the alternative models for scholarly publication on accessibility?**

Given that some of the alternative publishing models under consideration are in their early days, it is difficult to answer this question definitively. Nevertheless, there are a number of possible approaches.

*First, simple proxy measures of access.* For example, in the UK, SCONUL libraries reported acquisition/accession to some 1.4 million serials titles, with a mean of 8,391 and a median of 5,864 across the responding higher education institutions in 2006-07. Based on Ulrich's, the ISI Web of Knowledge and other sources, it is widely held that there are around 23,000 to 25,000 peer reviewed journals (and perhaps some 64,000 in total). For our estimations we use the 23,750 peer reviewed titles figure reported by Björk *et al.* (2008) and their estimation that 90% of titles are toll access.

By no means all serials are journals and there are likely to be duplicate subscriptions within institutions, but even if they were all journals, all peer reviewed and there were no duplicate subscriptions the mean of SCONUL library subscriptions would represent around 39% of titles and the median 27% – suggesting that perhaps 60% to 70% of possible titles are not being made available in this way.<sup>89</sup>

Björk *et al.* (2008) suggested that around 11.3% of articles are green OA and a further 3.5% delayed OA, so perhaps 15% of toll access content is already available OA and should not be included in estimates of the accessibility differences between toll and OA publishing and self-archiving models. Hence, as a simple proxy, perhaps 50% of possible journal titles are not readily accessible to higher education researchers in the UK.

*Second, estimates of OA citation advantage.* As noted elsewhere, there are many studies and active discussion of a possible OA citation advantage, with general agreement that there does seem to be an observable advantage and argument focusing mainly on why (EPS *et al.* 2006). The observed advantages vary considerably, with Hajjem *et al.* (2005) concluding that:

---

<sup>89</sup> Of course, there are a range of language and other constraints and individual institutions do not need all journals (*e.g.* they may not have a medical school). Nevertheless, accessibility is likely to be at its greatest in SCONUL research libraries and substantially more constrained elsewhere.

*In 2001, Lawrence found that articles in computer science that were openly accessible (OA) on the Web were cited substantially more than those that were not. We have since replicated this effect in physics. To further test its cross-disciplinary generality, we used 1,307,038 articles published across 12 years (1992-2003) in 10 disciplines (Biology, Psychology, Sociology, Health, Political Science, Economics, Education, Law, Business, Management). The overall percentage of OA (relative to total OA + NOA) articles varies from 5%-16% (depending on discipline, year and country) and is slowly climbing annually. Comparing OA and NOA articles in the same journal/year, OA articles have consistently more citations, the advantage varying from 25%-250% by discipline and year.*

Hence, as starting point one might take 25% as a conservative estimate of the potential citation advantage of OA publishing models.

### Box 5.1: Model parameter: Percentage change in accessibility

| <b>Parameter</b>  | <b>Basis</b>  | <b>Value</b>                  |
|---|---|-------------------------------|
| Percentage change in accessibility (access)                                       | (i) 50% of the 20% of the stock of knowledge that is journals<br>(ii) 50% of the 40% of the stock of knowledge that is publications | 10% to 20%                    |
| Percentage change in accessibility (OA citation)                                  | (i) 25% of the 20% of the stock of knowledge that is journals<br>(ii) 25% of the 40% of the stock of knowledge that is publications | 5% to 10%                     |
| <b>Combined estimate of the percentage change in accessibility to be modelled</b> | <b>Conservative consensus of the above</b>  | <b>5% to 10%, estimate 5%</b> |

Source: Authors' analysis.

### Efficiency: rationale for the range to be modelled

*Efficiency* is defined as the proportion of R&D spending that generates useful knowledge, and can have a number of dimensions relating to wasteful, inefficient and/or poorly directed research expenditure. The key issue is what impact might alternative models for scholarly publishing have on efficiency?

Drawing on the analysis of the literature summarised above, key dimensions might include:

- Researcher and research system cost savings that might arise from alternative publishing models, with those savings being spent doing more research for the same level of R&D spending, and thereby producing more useful knowledge for a given spend;
- The potential avoidance of duplicative and ill-informed research, and of scientific fraud and plagiarism, and thereby the reduction of wasteful expenditure;



- The potential for reduction in accessibility delays leading to a speeding up of the research and discovery process, thereby producing more useful knowledge for a given cost;
- The potential for better and/or more informed review and evaluation of funding proposals and research outputs leading to better allocation of grants, block and other funding, thereby providing support to more productive and useful research and thereby producing more useful knowledge for a given cost;
- The potential for greater support of interdisciplinary research and collaborative research (*e.g.* inter-sectoral collaborations) leading to greater research focus on problems in areas of greater and/or more immediate impact (*e.g.* climate change), thereby producing more useful knowledge;
- The potential to enable greater research participation from developing countries, thereby unlocking new potential to generate more useful knowledge;
- etc.

With many possible impacts on efficiency, but few immediately available metrics, the best we can do is to explore a few plausible scenarios as a way to get a sense of the potential scope and scale of possible impacts (for illustrative purposes only).

**Scenario: Less risk of duplicative research being done through greater access and more complete and faster publication**

If just 2% of total research time were spent performing duplicative research that could have been avoided if researchers had had more complete and immediate access to the findings of others, then the annual ‘saving’ would have been more than £465 million nationally in the UK from Gross Expenditure on R&D circa 2006, of which the ‘saving’ in higher education expenditure on R&D would have been around £120 million – equivalent to around 8.2 million and 2.2 million researcher hours, respectively. With returns to publicly funded R&D at a conservative 20%, the implied lost annual returns (*i.e.* from the same amount of research expenditure that was not duplicative) would have been around £93 million nationally and £24 million from higher education. This implies a possible overall loss to the UK of up to £555 million per annum, of which £145 million could have been realised from higher education.

**Scenario: Less risk of pursuing blind alleys through greater access and more complete and faster publication**

If a similar 2% of research time is spent pursuing blind alleys could have been avoided if researchers had more complete and immediate access to the findings of others, then the same impacts and savings could be realised (*i.e.* £555 million nationally per annum, of which £145 million from higher education).



**Box 5.2: Model parameter: Percentage change in efficiency**

| <b>Parameter</b>  | <b>Basis</b>                                 | <b>Value</b>          |
|---|--|-----------------------|
| Percentage change in efficiency (wasteful expenditure: duplicative research and blind alleys) | Authors' estimate, for illustrative purposes | 1% to 5%, estimate 2% |
| Percentage change in efficiency (new opportunities: collaborative opportunities)              | Authors' estimate, for illustrative purposes | 1% to 5%, estimate 2% |
| Percentage change in efficiency (speeding up the process)                                     | Authors' estimate, for illustrative purposes | 1% to 5%, estimate 2% |
| <b>Combined estimate of the percentage change in efficiency to be modelled</b>                |  | <b>5%</b>             |

Source: Authors' analysis.

**Scenario: Enhanced and more immediate access speeds up the research and discovery process**

It has been suggested that more open access not only increases citations but leads to earlier citation (EPS *et al.* 2006; Schwarz and Kennicutt 2004; Brody and Harnad 2005), suggesting that the research and discovery process may be accelerated. This implies that less research time would be required for a given output/outcome or that more research could be done for the same expenditure (cost and/or time). If this increased the returns to R&D spending by 2%, then it would have been worth around £465 million per annum nationally circa 2007, and £120 million for higher education alone – equivalent to 8.2 million and 2.2 million researchers hours, respectively.

**Scenario: Collaborative research made possible by near universal access to the entire body of research publications brings higher returns to R&D**

It is widely held that there are advantages to collaborative research and greater use of the findings of collaborative work (Katz and Hicks 1997; Katz and Martin 1997; Walsh and Maloney 2001). If collaboration increased the returns to R&D by a similar 2%, then it too would have been worth around £465 million per annum nationally circa 2007, and £120 million for higher education alone – equivalent to 8.2 million and 2.2 million researchers hours, respectively.

**Scenario: Sum of efficiency implications for research expenditures and returns**

Combined (*i.e.* the simple sum, rather than compounded), these efficiency gains from more open access could realise an estimated £2 billion per annum nationally for the UK at 2006-07 prices and levels of expenditure, of which around £535 million could be realised from higher education (equivalent to 8.8% of R&D expenditure).<sup>90</sup>

Hence, as a conservative value we take a 5% increase in efficiency as a plausible starting point for modelling.

<sup>90</sup> As there were no directly negative impacts arising from more open and enhanced access for researchers, there are no costs for the performers of research to offset these potential savings and the savings (benefits) are net.

## Returns to R&D: rationale for the range to be modelled

There have been many studies exploring the economic impacts of R&D at the firm, industry and national levels.<sup>91</sup> A characteristic finding is that the social returns to R&D are high – often in the region of 30-60%, and higher in some cases (Bernstein and Nadiri 1991; Griliches 1995; Industry Commission 1995; Salter and Martin 2001; Scott *et al.* 2002; Dowrick 2003; Shanks and Zheng 2006; Martin and Tang 2007). While there is considerable variation in the rates of return reported (Table 5.1), these rates are indicative. Coe and Helpman (1993), Jones and Williams (1998) and others have shown that similar rates of return arise from endogenous growth models, and champions of the evolutionary approach suggest that, limited to seeing new knowledge as the output of research, simple growth models do not include other forms of economic benefit (*e.g.* skills development, development of instrumentation, development of networks, etc.) (Salter and Martin 2001; Scott *et al.* 2002; Martin and Tang 2007).<sup>92</sup> Thus simple growth models are likely to underestimate the contribution of R&D and should be taken as lower bound estimates of that contribution (Griliches 1995). As such, the approach adopted herein is conservative, if anything, under-estimating the potential impacts (see further discussion below).

**Table 5.1: Estimates of private and social rates of return to private R&D**

| <i>Study</i>              | <i>Private rate of return (%)</i> | <i>Social rate of return (%)</i> |
|---------------------------|-----------------------------------|----------------------------------|
| Minnasian (1962)          | 25                                | ..                               |
| Nadiri (1993)             | 20-30                             | 50                               |
| Mansfield (1977)          | 25                                | 56                               |
| Terleckyj (1974)          | 27                                | 48-78                            |
| Sveikauskas (1981)        | 10-23                             | 50                               |
| Goto & Suzuki (1989)      | 26                                | 80                               |
| Mohnen & Lepine (1988)    | 56                                | 28                               |
| Bernstein & Nadiri (1988) | 9-27                              | 10-160                           |
| Scherer (1982, 1984)      | 29-43                             | 64-147                           |
| Bernstein & Nadiri (1991) | 14-28                             | 20-110                           |

Source: Salter, A.J. and Martin, B.R. (2001) 'The economic benefits of publicly funded basic research: a critical review,' *Research Policy* 30(3), 514.

In establishing what is a plausible range of rates of return to use, we take a lead from the literature. Dowrick (2003, p16) noted that:

*Estimates of private returns to firms' own investment in R&D still produce varying figures, but there is an emerging consensus that gross returns in the range between 20% and 30% are both common and plausible. Taking account of risk-premia required to finance commercial R&D and taking account of depreciation rates on R&D capital, the net private return on R&D investment appears to be broadly comparable with the return on investment in physical capital.*

<sup>91</sup> Useful reviews of this literature include Industry Commission 1995, Griliches 1995; Salter and Martin 2001; Scott *et al.* 2002; Dowrick 2003; and Shanks and Zheng 2006.

<sup>92</sup> There are also measurement limitations in national accounts.

*Microeconomic studies confirm the existence of significant spillovers of knowledge from the firms that perform the R&D to other firms and industries. Taking account of measured spillovers typically raises the estimated gross rate of return on business investment into the range between 30% and 40%. But authors warn that these are likely to be underestimates of the true social rate of return because the microeconomic studies do not usually cover all of the sectors of the economy.*

*Macroeconomic studies, which by definition cover all sectors of the economy, do indeed find significantly higher returns to R&D in OECD countries, with estimates ranging from 50% to over 100%. Macroeconomic studies that distinguish between public and private sector R&D and allow for longer lags for the latter to affect productivity, find that public sector R&D contributes significantly to productivity, albeit less strongly than private sector R&D.*

Similarly, The Federation of Australian Scientific and Technological Societies (HORSCOSI 2003, p65) stated that:

*There have been a number of studies over the last six to ten years which, in a number of major OECD countries, have shown that the return on investment in R&D is of the level of 25-30% direct return (to the individual firm). Then there is an additional rate of return, which is another 25% on top of that, to raise it to the order of 50-60% return. That is known as a “social rate of return” whereby the indirect benefits of that research, which perhaps were not even envisaged by the original researcher, are captured by other people and turned into new products and new technologies.*

In one of the most thorough summaries of the literature, Martin and Tang (2007, pp6-7) noted that:

*...there have been numerous attempts to measure the economic impact of publicly funded research and development (R&D), all of which show a large positive contribution to economic growth. For instance, the studies cited in OTA (1986) and Griliches (1995) spanning over 30 years of work find a rate of return to public R&D of between 20 and 50%...*

*Mansfield (1991)... estimated the rate of return for academic research to be 28%. In a follow-up study, Mansfield (1998) found that academic research was increasingly important for industrial innovation...*

*Toole (1999) has shown... that firms appropriate a return on public science investment of between 12% and 41%.*

Exploring the local versus global impacts in the Netherlands Verspagen (2004) concluded that:

*The results show that the overall impact of academic knowledge may be sizable: between one quarter and one half of total productivity growth may be attributable to the ‘global library’ of academic knowledge... the calculations yield a broad indication of upper... and lower... limits for rates of return... Based on an argument on the localization of knowledge spillovers, we can further pin the rate of return down to 59%.*

Arundel and Geuna (2004, p3) noted that estimates of the rate of return to publicly funded research ranged between 20% and 60%. The Productivity Commission (2007) concluded that the marginal rate of return to R&D elicited through public sector support lies between 35% and 100%. It is also noted that differences in rates of return to R&D across different countries are not large (Cutler *et al.* 2008).

Consequently, we adopt a range of 20% to 60% for estimations, and for the purposes of discussion use the lower bound 20% as a very conservative rate return to expenditure on public sector research.

### Box 5.3: Model parameter: Rate of return to R&D and other parameters

| <b>Parameter</b>                     | <b>Basis</b>                           | <b>Value</b>  |
|--------------------------------------|--|---|
| Social returns to R&D                | Conservative consensus from literature | 20% to 60%, estimate 20%                                |
| Rate of growth in R&D spending       | UK National Statistical Office         | 5% per annum (current prices)                           |
| Lag between R&D spending and impacts | Mansfield (1991, 1998)                 | 3 years to publication plus 7 years to impact, 10 years |
| Discount rate (risk premium)         | Conservative consensus from literature | 10% per annum   |
| Rate of cost increases               | Conservative estimate from CPI         | 3% per annum  |

Source: Authors' analysis.

### Other parameters: rationale for the range to be modelled

There are a number of other assumptions in the modelling of impacts over 20 years, for which we have adopted conservative values so as not to risk overstating the benefits and understating costs. The major assumptions include:

**Rate of growth or R&D spending:** Various subsets of R&D spending are examined and there are some differences in spending trends. By sector of execution, GERD increased by 4.9% per annum between 1996 and 2006 (in current prices), HERD by 8.1% and GovERD by less than 1%. UK science allocations have increased by 5.5% per annum.

*Estimate for the model 5% per annum.*

**Lag between spend and impacts:** Lags between research spending and impacts being felt can be very long in some fields, perhaps 20 to 30 years, and short in others, perhaps 1 to 2 years or less. Mansfield (1991) reported that for US firms the average lag between the publication of academic research and the timing of subsequent commercial innovation relying on it was seven years. One might expect some speeding up of the research and commercialisation process since that time, but we model a lag of 10 years for the base case to take account of the seven years reported in the literature and allow a further three years for the lag between project commencement and publication.

*Estimate for the model 10 years.*

**Discount rate:** There is active discussion of the appropriate discount rate to use in cost-benefit calculation, with some suggesting very low rates and others much more conservative rates (Evans and Sezer 2002; Harrison 2007).

*Estimate for the model 10% per annum.*

**Rate of depreciation of the underlying knowledge stock, and hence benefits:** Depreciated from year of R&D at 10%.

*Estimate for the model 10% per annum.*

**Inflation/cost increases:** Costs change differently in different areas, but overall inflation gives an approximate guide and we adopt a conservative 3% per annum for cost inflation (importantly, reflecting an upper bound rate of increase in academic salaries). The exception is in the costs relating to OA publishing which we inflate by 5% per annum to reflect the historical relationship between R&D expenditure (growing at 5% per annum) and article production (a major driver of OA publishing costs).

*Estimate for the model 3% per annum (OA publishing fees 5% per annum).*

### 5.1.3 Modelled impacts on returns to R&D

We combine the bottom-up estimates of costs, cost savings and impacts outlined above with a top-down macro econometric model (*i.e.* the modified Solow-Swan model outlined above) in order to explore both the more direct costs and benefits of alternative scholarly publishing models and a ‘ballpark’ estimate of the impacts of those models on social returns to R&D – which are, after all, the point of the research expenditure.

Table 5.2 presents the modelled estimates of the impacts of a one-off increase in ‘accessibility’ and ‘efficiency’ on returns to R&D based on 2006 research expenditures, with percentage changes in ‘accessibility’ and ‘efficiency’ shown cumulatively (*i.e.* 5% represents a cumulative 5% change in both parameters).<sup>93</sup>

For the major categories of research expenditure in the UK in 2006, given a 20% social return to publicly funded R&D, a 5% increase in ‘accessibility’ and ‘efficiency’ would have been worth:

- £172 million per annum in increased returns to public sector R&D (*i.e.* government and higher education by sector of execution);
- £124 million per annum in increased returns to Higher Education R&D (HERD);
- £109 million per annum in increased returns to Government funded R&D (GovERD); and
- £33 million per annum in increased returns to Research Councils UK (RCUK) competitive grants funded R&D.<sup>94</sup>

---

<sup>93</sup> We assume that the change in ‘accessibility’ and ‘efficiency’ has no net impact on the rates of accumulation and obsolescence of the stock of research knowledge.

<sup>94</sup> Estimates of the social returns to R&D are based on aggregates, such as national expenditure or sectoral expenditure, for which they can be reasonably accurate. Their use for specific forms of R&D,

Table 5.2: Estimates of the impacts of a one-off increase in accessibility and efficiency on returns to R&amp;D (GBP millions)

| <b>Public Sector</b>                            |   | Rate of return to R&D |     |     |       |     |
|---|---|-----------------------|-----|-----|-------|-----|
| £8,380 million                                  |   | 20%                   | 30% | 40% | 50%   | 60% |
| Per cent change in accessibility and efficiency | Recurring annual gain from increased accessibility & efficiency (million) |                       |     |     |       |     |
| 1%  | 34  | 51                    | 67  | 84  | 101   |     |
| 2%  | 68  | 102                   | 135 | 169 | 203   |     |
| 5%  | <b>172</b>  | 258                   | 344 | 429 | 515   |     |
| 10%   | 352   | 528                   | 704 | 880 | 1,056 |     |

| <b>Higher Education (HERD)</b>                  |   | Rate of return to R&D |     |     |     |     |
|---|---|-----------------------|-----|-----|-----|-----|
| £6,062 million                                  |   | 20%                   | 30% | 40% | 50% | 60% |
| Per cent change in accessibility and efficiency | Recurring annual gain from increased accessibility & efficiency (million) |                       |     |     |     |     |
| 1%  | 24  | 37                    | 49  | 61  | 73  |     |
| 2%  | 49  | 73                    | 98  | 122 | 147 |     |
| 5%  | <b>124</b>  | 186                   | 249 | 311 | 373 |     |
| 10%   | 255   | 382                   | 509 | 637 | 764 |     |

| <b>Government (GovERD)</b>                      |   | Rate of return to R&D |     |     |     |     |
|---|---|-----------------------|-----|-----|-----|-----|
| £5,309 million                                  |   | 20%                   | 30% | 40% | 50% | 60% |
| Per cent change in accessibility and efficiency | Recurring annual gain from increased accessibility & efficiency (million) |                       |     |     |     |     |
| 1%  | 21  | 32                    | 43  | 53  | 64  |     |
| 2%  | 43  | 64                    | 86  | 107 | 129 |     |
| 5%  | <b>109</b>  | 163                   | 218 | 272 | 327 |     |
| 10%   | 223   | 334                   | 446 | 557 | 669 |     |

| <b>Research Councils (RCUK)</b>                 |   | Rate of return to R&D |     |     |     |     |
|---|---|-----------------------|-----|-----|-----|-----|
| £1,601 million                                  |   | 20%                   | 30% | 40% | 50% | 60% |
| Per cent change in accessibility and efficiency | Recurring annual gain from increased accessibility & efficiency (million) |                       |     |     |     |     |
| 1%  | 6   | 10                    | 13  | 16  | 19  |     |
| 2%  | 13  | 20                    | 26  | 33  | 39  |     |
| 5%  | <b>33</b>   | 50                    | 66  | 83  | 99  |     |
| 10%   | 68  | 101                   | 135 | 169 | 203 |     |

Note: R&D expenditure for Public Sector and HERD is by sector of execution, while GovERD and RCUK is by sector of funding.

Source: EI-ASPM model: Authors' analysis.

These are recurring annual gains from the effect of one year's R&D, such that if the change that brings the increases in 'accessibility' and 'efficiency' is permanent they can be converted to growth rate effects.

such as RCUK grants funding, will be subject to greater uncertainty and should be treated with caution.

## How local are these returns?

There are various ways to explore the likely localisation of returns and impacts felt within a country.

**Economic studies on localisation of returns:** A number of studies have looked at the issue of the relative impact of local research on local returns and/or the international spillover of R&D. Coe and Helpman (1993) adopted a trade weighting approach, but with increasing intra-industry and intra-firm trade it may be that its usefulness is becoming somewhat questionable. Verspagen (2004), based on Adams (1990), addressed the question of local impacts of locally produced journal articles, finding, not surprisingly (in the Netherlands), that the local production to local use of knowledge was limited. However, many studies have explored the importance of local knowledge production capacity for local recognition, absorption, adoption and application (Benhabib and Spiegel 1994; Frantzen 2000; Dowrick and Rogers 2002; Griffith *et al.* 2004; Guellec and van Pottelsberghe de la Potterie 2001; etc.). Generally, and especially in smaller countries, such local capacity is more important than local production. Hence, the share of worldwide production of journal articles may be a poor guide to the relative contribution of local research to local innovation.

Jaffe (1989) suggested that domestic knowledge was twice as important as foreign knowledge. Verspagen (2004, p10), citing Arundel and Guena (2004), suggested weights for domestic versus foreign sources – of 73% for domestic and 27% for foreign sources. Indicatively, applying these weights to the estimated range of social returns 20% to 60% outlined above, would suggest that the UK share of returns to UK research expenditure would be 29% as a point estimate (*i.e.* 73% of 40%), or lie in the range between 15% and 44%. Hence our 20% assumption is conservative, relative to the point estimate of 29%.<sup>95</sup>

**Repository statistics:** Repository statistics are another possible source of information on the localisation of use of scholarly work, especially that which is open access. Unfortunately they present a very mixed picture, with national downloads (*i.e.* those to the country-code top level domain – ccTLD) varying from highs of 95% and more to lows of 20% and less. In the small sample explored (N=12), however, the mean across repositories is around 45%. Such download percentages will tend to understate the share of local use as there is likely to be a further share of local global top level domains (gTLDs) that remain unidentified in the data as well as a substantial number of unresolved domains. Indicatively, perhaps, one could add 45% of the gTLD and unresolved traffic. As such, the evidence of local use from repository download statistics is broadly in accord with the Arundel and Guena (2004) weighting of 73% of returns being local.

---

<sup>95</sup> In addition to this, of course, there would be spillover returns to foreign R&D expenditure realised locally (*i.e.* spillovers spilling into the UK as well as out).



## 6 Comparing costs and benefits

In this section we attempt to compare costs and benefits. As noted, it is not possible to compare toll with open access publishing directly at the national level as they perform very different roles: toll access publishing seeks to provide UK subscribers with access to worldwide research (to the limits of affordability), whereas open access seeks to provide worldwide access to UK research. Therefore, we approach the question from both sides.

### Box 6.1: A brief description of the model

**Main characteristics:** A spreadsheet model to estimate the impacts of increases in ‘accessibility’ and ‘efficiency’ on returns to R&D over 20 years in a 20 by 20 matrix, with three data inputs: (i) R&D expenditure, (ii) annual costs associated with the publishing model, and (iii) annual savings resulting from the publishing model (in the net cost scenarios only).

**Assumptions and parameters:** All the parameters can be changed in order to explore various scenarios and test sensitivities. As outlined in the previous section, they include: (i) the rate of social return to R&D, (ii) the rate of depreciation of the underlying stock of knowledge, (iii) the discount rate applied to costs and benefits to estimate net present value, (iv) the rate of growth of R&D expenditure, (v) the rate of growth of costs associated with the alternative publishing scenario being explored, (vi) the average lag between publication or self-archiving and returns to R&D in years, and (vii) the average lag between R&D expenditure and publication in years.

**Transition versus ‘steady-state’ alternative:** Because of the lag between research expenditure and the realisation of economic and social returns to that research, the impact on returns to R&D is lagged (by 10 years in the base case scenario) and the value of those returns discounted accordingly. This reflects that fact that a shift to OA publishing or self-archiving would be prospective and not retrospective, and the economic value of impacts of enhanced accessibility and efficiency would not be reflected in returns to R&D until those returns are realised.

An alternative approach would be to model a hypothetical alternative ‘steady-state’ system for alternative publishing models in which the benefits of historical increases in *accessibility* and *efficiency* enter the model in year one. This would reflect the situation in an alternative system, after the transition had worked through and was no longer affecting returns to R&D.

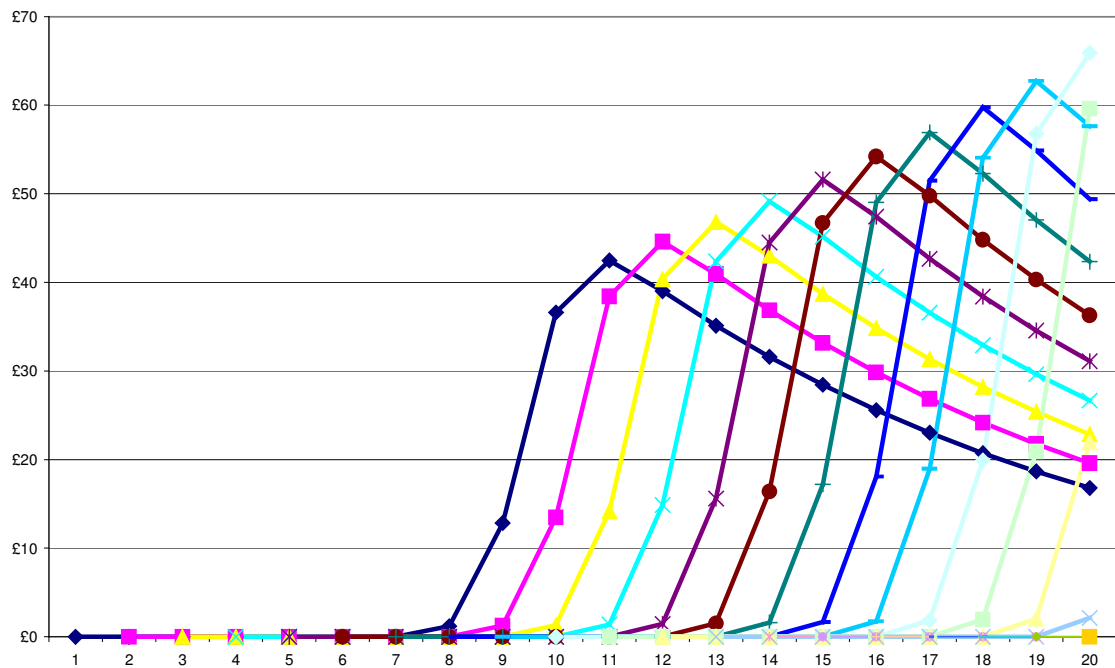
The model used herein to estimate impacts focuses on the transition and explores alternative models through a series of scenarios over a 20 year transitional period. However, the possible impacts in a hypothetical ‘steady-state’ alternative system are explored indicatively by introducing the estimated annual increase in returns into year one. This effectively removes the lag, but is no more than indicative because it does not include the recurring gains from historical expenditures occurring before year one.

Source: Authors’ analysis.

Box 6.1 contains a brief description of the model used to explore impacts on returns to R&D, in which we operationalise the conceptual model outlined in above. The most important feature to note is that we are modelling the transition to alternative publishing models over 20 years.

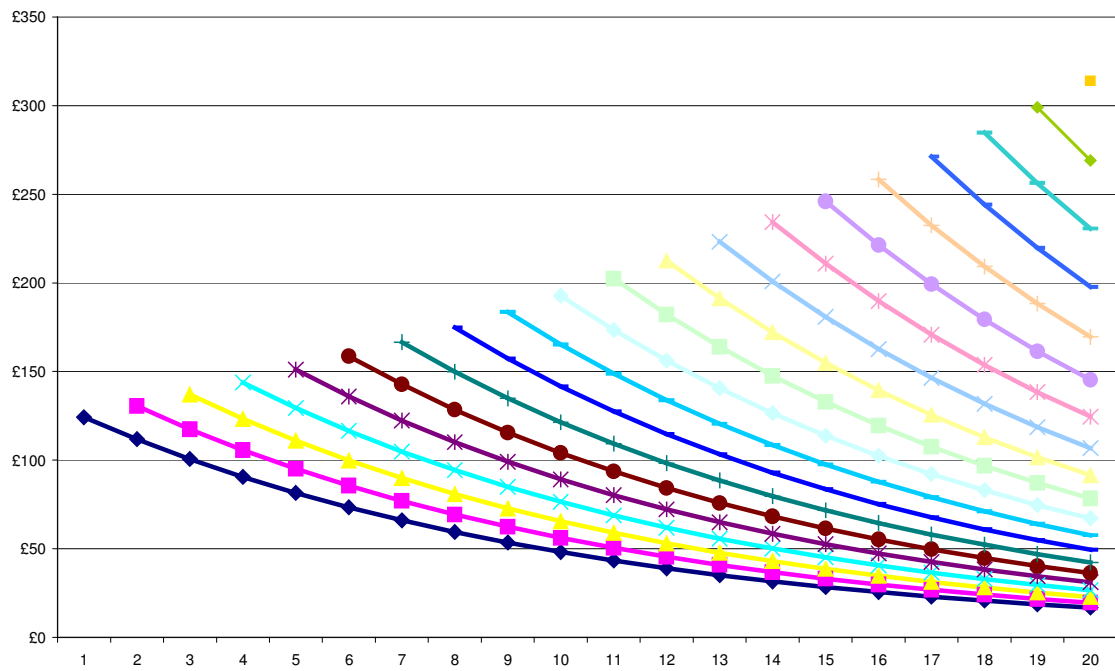


Figure 6.1: Benefit profiles in a transitional model: Increased returns to R&D over 20 years (GBP millions)



Source: EI-ASPM model: Authors' analysis.

Figure 6.2: Benefit profiles in a steady-state model: Increased returns to R&D over 20 years (GBP millions)



Source: EI-ASPM model: Authors' analysis.

Because of the lag between research expenditure and the realisation of economic and social returns to that research, the impact on returns to R&D is lagged by 10 years (in the base case scenario) and the value of those returns discounted accordingly. This reflects the fact that a shift to OA publishing or self-archiving would be prospective and not retrospective, and that the economic value of impacts of enhanced accessibility and efficiency would not be reflected in returns to R&D until those returns are realised. Put simply, this has the effect that over a transitional period of 20 years we are comparing 20 years of costs with 10 years of benefits (Figure 6.1).

An alternative approach would be to model a hypothetical ‘steady-state’ system for alternative publishing models in which the benefits of historical increases in accessibility and efficiency enter the model in year one. This would reflect the situation in an alternative system, after the transition had worked through and was no longer affecting returns to R&D. Put simply, in such a model one would be comparing 20 years of costs with 20 years of benefits (Figure 6.2).

We took the view that it was more realistic and interesting, and of more immediate concern, to model the transition. Nevertheless, it must be emphasised that a transitional model returns significantly lower benefit/cost ratios than would a hypothetical alternative ‘steady-state’ model. To explore the extent of the difference we ‘force fed’ our transitional model by simply putting the increase in returns to R&D into year one – effectively ignoring the lag between R&D expenditure and the realisation of impacts and thus simulating the situation in which the benefits of historical increases in accessibility and efficiency enter the model in year one. To an approximation, the increased returns in a ‘steady-state’ model might be 3 to 10 times greater than in the transitional model.

## 6.1 Ceteris paribus scenarios

First, we explore the benefit/cost implications of simply adding OA publishing and/or self-archiving to current activities (predominantly toll access publishing), all other things remaining the same (*i.e.* neither OA publishing nor self-archiving lead to cancellation of subscriptions and the alternative publishing models run in parallel) (Figure 6.3). Of course, the first scenario is rather meaningless as it is most unlikely that all UK authored journal articles would be published under both subscription and ‘author-pays’ publishing models simultaneously.

### 6.1.1 OA publishing (UK national and Higher Education)

We estimate that an all author/producer side funded OA publishing system for all journal articles produced in the UK would have cost around £170 million nationally in 2007, of which around £150 million would have related to higher education outputs – approximately 0.74% of GERD and 2.43% of HERD, respectively.

Ignoring potential cost savings and given the assumptions outlined above (including inflating costs at the higher 5% per annum), we estimate that over 20 years:

- The cost of OA publishing for higher education would be around £1.8 billion in Net Present Value, whereas the estimated impact on returns to Higher Education R&D

(HERD) would be around £615 million, a benefit/cost ratio of 0.3 (*i.e.* the benefits would be less than the costs); and

- The cost of OA publishing nationally would be around £2 billion in Net Present Value, whereas the estimated impact on returns to UK Gross Expenditure on R&D (GERD) would be around £2.4 billion, a benefit/cost ratio of almost 1.1 (*i.e.* the benefits would be marginally greater than the costs) (Table 6.1).

Of course, neither is very realistic as journal articles would not be published in both OA and subscription journals in parallel. As such, this is a worse than worst possible case scenario (*i.e.* paying twice to publish everything).

Nevertheless, putting the notional impacts of enhanced access into year one to simulate a post-transition 'steady-state' alternative OA publishing system, returns a benefit/cost ratio of 3.8 for higher education and 12.7 nationally. This suggests that even with unrealistic parallel publishing scenarios the benefits of an OA publishing system could outweigh the costs.

### 6.1.2 OA self-archiving (UK national and Higher Education)

We estimate that a system of OA (publications) repositories for journal articles with all outputs posted once, would have cost the UK around £23 million per annum nationally in 2007, of which £18 million per annum would have related to higher education.

Ignoring potential cost savings and given the assumptions outlined above, we estimate that over 20 years:

- The cost of OA self-archiving for higher education would be around £189 million in Net Present Value, whereas the estimated impact on returns to Higher Education R&D (HERD) would be around £615 million, a benefit/cost ratio of 3.2; and
- The cost of OA self-archiving nationally would be around £237 million in Net Present Value, whereas the estimated impact on returns to UK Gross Expenditure on R&D (GERD) would be around £2.4 billion, a benefit/cost ratio of 9.9 (Table 6.1).

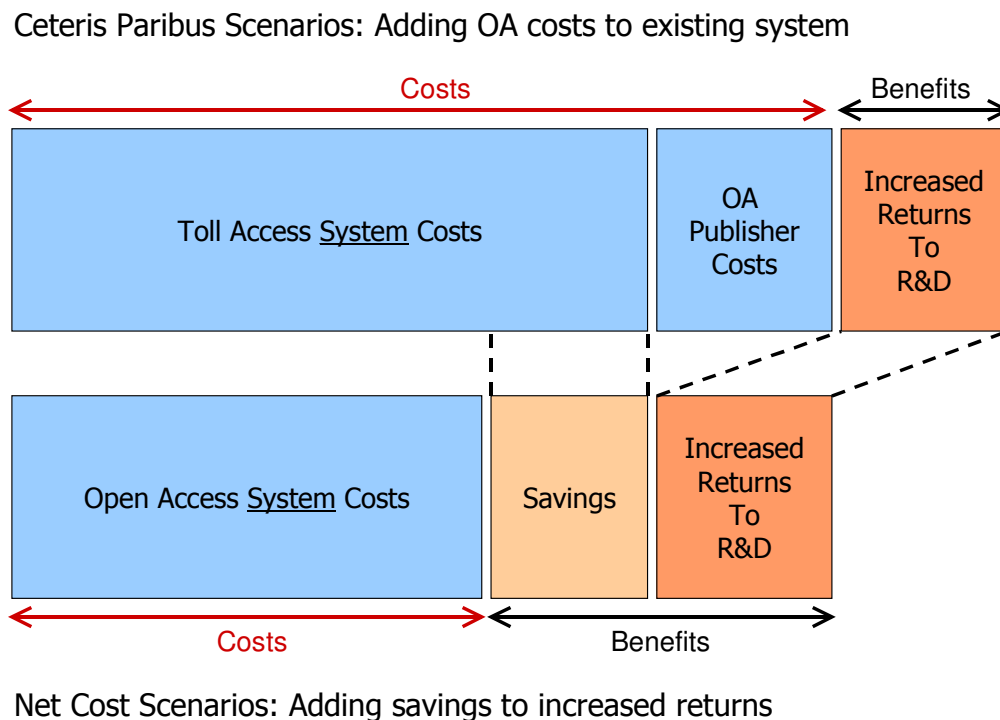
These comparisons suggest that the additional returns from enhanced accessibility and efficiency alone would be sufficient to cover the costs of OA self-archiving in parallel with subscription publishing (*i.e.* 'Green OA' self-archiving *without* subscription cancellations), independent of the activity cost savings noted above.

Indicatively, putting the notional impacts of enhanced access into year one to simulate a post-transition 'steady-state' alternative OA self-archiving system, returns a benefit/cost ratio of 36 for higher education and 110 nationally. This suggests that the benefits of an OA self-archiving system with overlay services would substantially outweigh the costs.

## 6.2 Net cost scenarios

Second, we explore the benefit/cost implications of OA publishing and/or self-archiving as alternatives to current activities, by adding the estimated savings to estimated returns (*i.e.* comparing the three publishing models as alternatives) (Figure 6.3).

Figure 6.3: Conceptual map of benefit/cost scenarios



Source: Authors' analysis.

There are two elements to the net cost scenarios.

1. OA publishing and self-archiving models are lower cost alternatives, such that there are savings throughout the scholarly communication process. The implication of these savings is that the same output of knowledge can be produced with less expenditure or more knowledge could be produced with the same level of expenditure. These savings from direct publisher cost differences and indirect research and library handling cost differences are the first form of benefits.
2. OA publishing and self-archiving models do not depend on imposing limitations on access and permission to use, making the knowledge being conveyed more accessible and more useful. We modify the basic Solow-Swan model to take account of the impact of increasing accessibility and efficiency (*i.e.* that the knowledge is more accessible and more useable/useful) on returns to R&D spending. The increase in returns to R&D is the second form of benefits.

Hence, efficiency is being used in two slightly different senses – in the sense of producing more knowledge for a given level of expenditure, and in the sense of producing more useful knowledge through making it more accessibly and useable. These two forms of efficiency gains can be added together without fear of double counting.

**Table 6.1: Summary of benefit/cost comparisons by scenario and model (GBP millions and Benefit/Cost ratio)**

| <i>Scenario</i>   | <i>Costs</i> | <i>Savings</i> | <i>Benefits</i> | <i>Benefit/Cost Ratio</i> |
|---|--------------|----------------|-----------------|---------------------------|
| <b>Ceteris Paribus Scenarios</b>                            |              |                |                 |                           |
| <b><i>Transitional Model:</i></b>                           |              |                |                 |                           |
| OA Publishing in HE (unrealistic)                           | 1,787        | ..             | 615             | 0.3                       |
| OA Publishing Nationally (unrealistic)                      | 2,079        | ..             | 2,353           | 1.1                       |
| OA Repositories in HE                                       | 189          | ..             | 615             | 3.2                       |
| OA Repositories Nationally                                  | 237          | ..             | 2,353           | 9.9                       |
| <b><i>Simulated Steady State Model:</i></b>                 |              |                |                 |                           |
| OA Publishing in HE (unrealistic)                           | 1,787        | ..             | 6,876           | 3.8                       |
| OA Publishing Nationally (unrealistic)                      | 2,079        | ..             | 26,318          | 12.7                      |
| OA Repositories in HE                                       | 189          | ..             | 6,876           | 36.3                      |
| OA Repositories Nationally                                  | 237          | ..             | 26,318          | 110.8                     |
| <b>Net Cost Scenarios</b>                                   |              |                |                 |                           |
| <b><i>Transitional Model:</i></b>                           |              |                |                 |                           |
| OA Publishing in HE with direct savings                     | 1,787        | 968            | 615             | 0.9                       |
| OA Publishing in HE with direct and indirect savings        | 1,787        | 2,016          | 615             | 1.5                       |
| OA Repositories in HE with direct savings                   | 189          | 1,244          | 615             | 9.8                       |
| OA Repositories in HE with direct and indirect savings      | 189          | 2,148          | 615             | 14.6                      |
| OA Publishing Nationally with direct savings                | 2,079        | 1,127          | 2,353           | 1.7                       |
| OA Publishing Nationally with direct and indirect savings   | 2,079        | 2,575          | 2,353           | 2.4                       |
| OA Repositories Nationally with direct savings              | 237          | 1,447          | 2,353           | 16.0                      |
| OA Repositories Nationally with direct and indirect savings | 237          | 2,697          | 2,353           | 21.3                      |
| <b><i>Simulated Steady State Model:</i></b>                 |              |                |                 |                           |
| OA Publishing in HE with direct and indirect savings        | 1,787        | 2,016          | 6,876           | 5.0                       |
| OA Repositories in HE with direct and indirect savings      | 189          | 2,148          | 6,876           | 47.7                      |
| OA Publishing Nationally with direct and indirect savings   | 2,079        | 2,575          | 26,318          | 13.9                      |
| OA Repositories Nationally with direct and indirect savings | 237          | 2,697          | 26,318          | 122.2                     |

Note: Costs, savings and benefits are expressed in Net Present Value over 20 years, GBP millions. See modelling assumptions outlined in Section 5.

Source: EI-ASPM model: Authors' analysis.

### 6.2.1 OA publishing articles (Higher Education)

To the estimated cost of an all author/producer side funded OA publishing system for journal articles produced in UK higher education circa 2007 of £150 million we add the estimated direct publisher cost savings resulting from a shift from an all e-only toll access system to an all e-only OA publishing system for outputs circa 2007 (approximately £80 million per annum).

Given the assumptions outlined above, we estimate that over 20 years the direct publisher savings adjusted cost of OA publishing for higher education would be around £820 million in Net Present Value, whereas the estimated impact on returns to Higher Education R&D (HERD) would be around £615 million, a benefit/cost ratio of 0.9 (*i.e.* the benefits and costs are approximately equal).

However, to these direct publisher cost savings one can add those resulting from associated system savings, bringing total system savings to around £166 million per annum circa 2007 for higher education, such that under the same assumptions the costs of £1.8 billion over 20 years in Net Present Value can be set against the potential savings adjusted benefits of £2.6 billion, a benefit/cost ratio of 1.5 (*i.e.* the benefits are one-and-a-half times the costs). This gives a sense of the possible lower bound impacts in transition (under the given assumptions and costings).

Indicatively, putting the notional impacts of enhanced access into year one to simulate a post-transition ‘steady-state’ alternative OA publishing system, returns a benefit/cost ratio of 5, suggesting that while there may be transitional costs in an alternative OA publishing system the benefits would substantially outweigh the costs.

### 6.2.2 OA publishing articles (UK National)

Data on special library activities and study outside higher education are limited. Nevertheless, we can perform the same comparisons on known data (in which library handling savings relate to higher education alone, thus under-estimating national savings).

OA publishing costs for all UK research article outputs are estimated at £170 million circa 2007, or around £2 billion in Net Present Value over 20 years. Direct publisher and indirect system savings would be worth around £2.6 billion nationally over 20 years, and additional returns to Gross Expenditure on R&D (GERD) arising from increased accessibility and efficiency around £2.4 billion. Hence, in the transitional model, the benefit/cost ratio would be 2.4 (*i.e.* the benefits are 2.4 times the costs).

Indicatively, putting the notional impacts of enhanced access into year one to simulate a post-transition ‘steady-state’ alternative OA publishing system, returns a benefit/cost ratio of 13.9, suggesting that the benefits of an alternative OA publishing system would substantially outweigh the costs.

### 6.2.3 OA self-archiving articles (Higher Education)

To the estimated cost of an all OA self-archiving system (*i.e.* with commercial overlay article production services) for journal articles produced in UK higher education circa 2007 we add the estimated direct publisher cost savings from a shift from an all e-only toll access system to an all e-only OA self-archiving system for UK outputs circa 2007 (approximately £119 million).

Given the assumptions outlined above, we estimate that over 20 years the direct publisher savings adjusted cost of OA self-archiving for higher education would be negative (by around £1 billion in Net Present Value), whereas the estimated impact on returns to Higher Education

R&D (HERD) would be around £615 million, a benefit/cost ratio of 9.8 (*i.e.* the benefits are almost 10 times the costs).

To these direct publisher cost savings one could add those resulting from associated system savings, bringing total system savings to around £206 million per annum circa 2007 for higher education, such that under the same assumptions the costs of £190 million over 20 years in Net Present Value can be set against the potential savings adjusted benefits of £2.7 billion, a benefit/cost ratio of 14.6 (*i.e.* the benefits are 14 times the costs). This gives a sense of the possible lower bound impacts (under the given assumptions and costings).

Indicatively, putting the notional impacts of enhanced access into year one to simulate a post-transition ‘steady state’ alternative OA self-archiving system, returns a benefit/cost ratio of 47.7 – suggesting that the benefits substantially outweigh the costs.

#### **6.2.4 OA self-archiving articles (UK National)**

OA self-archiving costs for all UK research article outputs are estimated at around £240 million in Net Present Value over 20 years. Direct and indirect savings would be worth around £2.7 billion nationally over 20 years, and additional returns to Gross Expenditure on R&D (GERD) arising from increased accessibility and efficiency around £2.4 billion. Hence, in the transitional model, the benefit/cost ratio would be 21.3 (*i.e.* the benefits are more than 20 times the costs).

Indicatively, putting the notional impacts of enhanced access into year one to simulate a post-transition ‘steady-state’ alternative OA self-archiving system, returns a benefit/cost ratio of 122, suggesting that the benefits of an alternative OA publishing system would substantially outweigh the costs.

#### **6.2.5 Alternative OA publishing models in UK higher education**

These comparisons suggest that the additional returns from enhanced accessibility and efficiency alone would be sufficient to cover the costs of parallel OA self-archiving (*i.e.* Green OA), and when estimated savings are added to generate net costs there is a substantial increase in the benefit/cost ratios and for both OA publishing and self-archiving the benefits exceed the costs (even in transition). Moreover, the system savings alone also more than offset the costs for both OA publishing and self-archiving of journal articles in UK higher education, independent of increased returns.

Indicative modelling of post-transition ‘steady-state’ alternative systems, comparing alternative publishing models, suggests that once established alternative OA publishing and/or self-archiving systems would produce substantially greater benefits – such that in an alternative OA journal publishing system for UK higher education the benefits might be 5 times the costs, and in an alternative OA self-archiving system with overlay production and review services the benefits might be more than 45 times the costs.



## 6.3 FAQs

In this section we explore a number of frequently asked questions, beginning with the issue of diverting research funds to author/producer side payments for OA publishing, and then exploring the possible impacts of delayed OA and speeding up the research and discovery process.

### 6.3.1 Diversion of research funds to 'author-pays'

As noted, the estimated cost of OA publishing UK research journal article outputs circa 2007 was £170 nationally and £150 in higher education – 0.74% and 2.43% of UK Gross Expenditure on R&D (GERD) and Higher Education R&D (HERD), respectively.

#### **What proportion of research funding could be spent on OA publishing before the modelled benefits disappear?**

Taking the OA publishing net cost scenario as the starting point, we adjusted OA publishing costs upwards until they matched estimated benefits over 20 years – to approximately £215 million per annum or 3.5% of Higher Education R&D (HERD). Simplistically, this suggests that under the modelled assumptions funding agencies or institutions might be able to divert up to 3.5% of research funding to author/producer side fees before net benefits are exhausted – a level that is much higher than is commonly reported and one-and-a-half times that required (on estimated costs).

Of course, this is dependent on the returns characteristic for the field of research. Returns are typically substantially higher in medical research than elsewhere and might be expected to be lower in some areas of Humanities and the Arts, such that, for example, the percentage of funds at which breakeven might be reached would likely be higher for the Medical Research Council or Wellcome Trust than for Arts and Humanities Research Council.

**Table 6.2: Summary of benefit/cost comparisons: FAQs**

| <i>FAQ</i>                                   | <i>Impact</i>                            | <i>Metric</i> |
|--|--|---------------|
| Diversion of research funds to 'author-pays' | Breakeven level of funds diversion       | Approx. 3.5%  |
| Impact of 1 year embargo in 'delayed OA'     | 1 year delay reduces returns by          | 2%            |
| Speeding up the R&D process by 1 year        | 1 year acceleration increases returns by | 3.6%          |

Source: EI-ASPM model: Authors' analysis.

### 6.3.2 Impact of delays in delayed OA

The model contains a parameter which lags the impact of the change to enhanced access in years. It is possible to explore the impact of lags in access by adjusting this parameter, by which the period's increase in returns to R&D through increases in accessibility and efficiency can be accelerated or delayed. That is to say that one year's returns generated by a 5% increase in



accessibility and efficiency will be lost through each year of delay, and we use this to simulate the impact of a one year 'Delayed OA' embargo.

### **What is the impact of a one year embargo in 'Delayed OA'?**

For the major categories of public research expenditure in the UK circa 2006, a one year embargo in Delayed OA would reduce the increase in returns due to increases in accessibility and efficiency by around:

- £165 million from public sector R&D (*i.e.* government and higher education by sector of execution);
- £120 million from Higher Education R&D (HERD);
- £105 million from government funded R&D (*i.e.* GovERD including the research councils); and
- Around £30 million from research councils (RCUK) competitive grants funded R&D.

Over 20 years, such delays (equivalent to a one year Delayed OA embargo) reduce the estimated increases in returns to R&D by around 2% (in the transition model).

### **6.3.3 Speeding up the research and discovery process**

The model also contains a parameter which lags the impact of the R&D expenditure. As noted, Mansfield (1991) reported that for US firms the average lag between the publication of academic research and the timing of subsequent commercial innovation relying on it was seven years. In the base case scenarios we assume that it takes 10 years for the impacts of the research to be felt, allowing for a three year lag between project commencement and publication. It is possible to explore the impact of the potential for enhanced and/or earlier access (*e.g.* through self-archiving pre-prints) to speed up the research and discovery process by adjusting this parameter.

### **What is the impact of a one year reduction in the average lag between research and its impacts?**

For the major categories of research expenditure in the UK circa 2006, under the modelled assumptions a one year reduction in the impact delay (*i.e.* reducing the modelled lag between publication and impact from 7 years to 6 years) would have been worth around:

- £300 million in additional increases in returns to public sector R&D (*i.e.* government and higher education by sector of execution) over 20 years at Net Present Value;
- £220 million in additional increases in returns to Higher Education R&D (HERD);
- £190 million in additional increases in returns to government funded R&D (GovERD including the research councils); and
- Around £60 million in foregone increases in annual returns to research councils (RCUK) funded R&D.

Over 20 years, such a speeding up of the research and discovery process by one year (*e.g.* through self-archiving pre-prints) might increase the estimated increases in returns to R&D by around 3.6% (in the transition model).

## Summary, conclusions and recommendations

This section presents a brief summary of UK scholarly communication system costs and benefits, draws some brief conclusions and outlines areas for possible action and further research.

### 7 Summary

UK scholarly communication system costs are substantial. This section presents a brief summary of costs at the national and higher education levels, and then summarises the potential impacts of alternative scholarly publishing models.

#### 7.1 UK National scholarly communication costs

Reading scholarly works by UK-based researchers and academic staff is a major activity, probably costing around £7.7 billion annually circa 2007, and reading by those actively publishing (*i.e.* approximating reading in order to write) around £2.8 billion.<sup>96</sup> We estimate that preparing and externally reviewing research grant applications for the UK Research Councils (RCUK), Wellcome and Leverhulme Trusts alone may have cost around £140 million during 2007, and writing peer reviewed scholarly publications cost around £1.6 billion.

**Table 7.1: Estimated annual UK national scholarly communication activity costs (GBP, circa 2007)**

| <i>UK National</i>   | <i>Estimate</i>      |
|--|----------------------|
| Reading (Published Staff)                                  | 2,775,000,000        |
| Reading (Research Staff)                                   | 7,729,200,000        |
| Writing (ISI WoK based estimate of UK published output)    | 1,599,700,000        |
| Peer Review (Scaled to output counts)                      | 202,800,000          |
| Editorial activities (Scaled to published staff)           | 63,600,000           |
| Editorial board activities (Scaled to published staff)     | 7,000,000            |
| Preparing Grant Applications (RCUK, Wellcome & Leverhulme) | 117,500,000          |
| Reviewing Grant Applications (RCUK, Wellcome & Leverhulme) | 18,600,000           |
| Publisher Costs (Scaled to output counts)                  | 573,900,000          |
| <b>Total National System</b>                               | <b>5,358,200,000</b> |

Source: EI-ASPM model: Authors' analysis.

<sup>96</sup> All costs are expressed in 2007 UK pounds and, where necessary, have been converted to pounds using OECD published annual average exchange rates and adjusted to 2007 using the UK consumer price index published by the National Statistical Office.

The peer review of journal articles and research monographs conducted by researchers on behalf of publishers (*i.e.* external peer review activities) probably cost around £203 million during 2007, and the external journal editorial and editorial board activities of researchers around £70 million. We estimate that publisher costs relating to UK-authored publications probably amounted to around £575 million (excluding the external costs noted above). Summing these costs suggests that core scholarly publishing system activities may have cost around £5.4 billion in the UK during 2007.

## 7.2 UK Higher Education scholarly communication costs

Table 7.2 summarises these same estimated annual scholarly communication related activity costs for UK higher education (HE). It shows that the reading of scholarly works by academic staff probably cost around £5 billion during 2007, and reading by those actively publishing around £2.5 billion. We estimate that writing core peer reviewed scholarly publications in UK higher education cost around £1.5 billion, and preparing and reviewing research grant applications for the Research Councils (RCUK), Wellcome and Leverhulme Trusts alone probably cost around £130 million during 2007.

**Table 7.2: Estimated annual UK higher education scholarly communication activity costs (GBP, circa 2007)**

| <i>UK Higher Education</i>                                 | <i>Estimate</i>      |
|--|----------------------|
| Reading (Published Staff)                                  | 2,446,000,000        |
| Reading (Academic Staff)                                   | 5,097,500,000        |
| Writing (WoK based estimate of Higher Education output)    | 1,453,900,000        |
| Peer Review (Scaled to output counts)                      | 178,600,000          |
| Editorial activities (Scaled to published staff)           | 54,900,000           |
| Editorial board activities (Scaled to published staff)     | 6,100,000            |
| Preparing Grant Applications (RCUK, Wellcome & Leverhulme) | 109,500,000          |
| Reviewing Grant Applications (RCUK, Wellcome & Leverhulme) | 17,300,000           |
| Publisher Costs (Scaled to output counts)                  | 517,300,000          |
| <b>Total Higher Education System</b>                       | <b>4,783,800,000</b> |

Source: EI-ASPM model: Authors' analysis.

The peer review of journal articles and research monographs conducted on behalf of publishers by HE staff (*i.e.* external peer review activities) probably cost around £180 million during 2007, and the external journal editorial and editorial board activities of HE researchers around £60 million. We estimate that higher education output-related publisher costs probably amounted to around £515 million (excluding the external costs noted above). Summing these costs suggests that core scholarly publishing system activities may have cost around £4.8 billion in UK higher education during 2007.

Table 7.3 summarises a range of scholarly publishing costs relating to each of these publishing models. It shows that for UK higher education SCONUL library expenditures amounted to almost £600 million during 2006-07, including £205 million for acquisitions (*i.e.* for

subscription or toll access). These acquisition costs were equivalent to around £81 per journal title and £23 per non-serial item (*e.g.* books).

**Table 7.3: Estimated annual UK higher education scholarly communication infrastructure-related costs (GBP, circa 2007)**

| <i>UK Higher Education</i>                                   | <i>Estimate</i>      |
|--|----------------------|
| Library Acquisition (Subscription or toll access publishing) | 204,800,000          |
| Library non-Acquisition                                      | 392,600,000          |
| Acquisition Cost per Serial Title                            | 81                   |
| Implied acquisition cost per Article (Estimated)             | 0.68                 |
| Cost per article download                                    | 0.65                 |
| Acquisition Cost per non-serial item                         | 23                   |
| E-book accesses  | 4,406,856            |
| Cost per e-book access                                       | 5.33                 |
| Author-Pays Fees for all counted articles (OA publishing)    | 147,500,000          |
| Current Estimated Repository Costs (OA self-archiving)       | 10,700,000           |
| <b>ICT Infrastructure (Total Expenditure)</b>                | <b>1,178,700,000</b> |

Source: EI-ASPM model: Authors' analysis.

Open Access publishing all UK higher education journal article output in 2007 would have cost around £150 million. Given that it is said that no more than half of the OA journals operating actually charge author fees, perhaps £75 million would have been required for author-side fees. However, if the UK supported OA publishing in proportion to output, the remaining £75 million would have been paid in other forms of institutional support.

Open Access self-archiving costs are based on estimated repository costs, which are necessarily no more than approximate. Nevertheless, we estimate that the OA repositories in operation in the UK as of August 2008 may have involved annual costs of around £10 million, and a system of institutional repositories in UK higher education in which every institution had one publications-oriented repository and all publications were self-archived once would have cost around £20 million per annum at 2007 prices and levels of publication output.

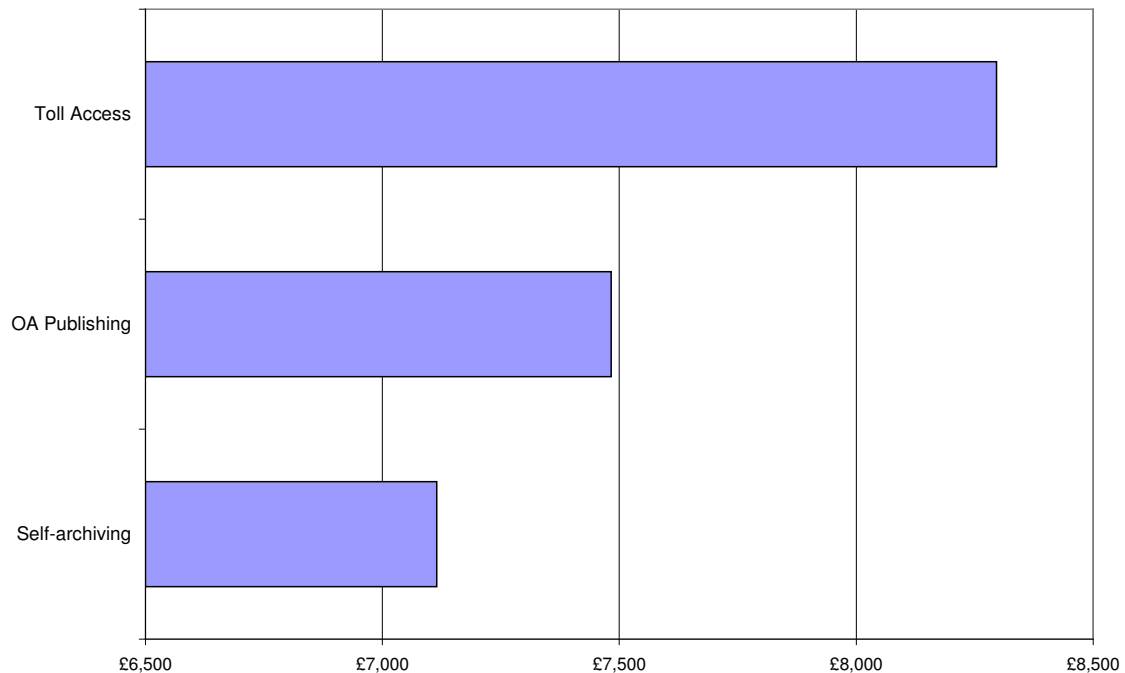
### 7.3 The impact of alternative scholarly publishing models

Summing the costs of production, publishing and dissemination *per article* in electronic-only format suggests that average toll access publishing system costs would amount to around £8,296 per article (excluding VAT), average OA publishing costs would amount to £7,483 per article and average OA self-archiving costs to £7,115 per article (including overlay review and production services and commercial margins). At these costs, OA publishing would be around £813 per article cheaper than toll access publishing, and OA self-archiving with overlay services around £1,180 cheaper (Figure 7.1).

For UK higher education, these cost differences would have amounted to savings of around £80 million per annum circa 2007 from a shift from toll access to OA publishing, and £116 million

from a shift from toll access publishing to OA self-archiving with overlay services. While alternative publishing models for books (*i.e.* research monographs) are much less developed and costings more speculative as a result, similar savings would appear to be available from shifting to OA book publishing.

Figure 7.1: Scholarly communication system costs per article (GBP, circa 2007)



Note: Includes the direct costs of writing, peer review, publishing and disseminating in e-only format. Self-archiving includes production and review costs, including commercial margins (*i.e.* overlay services).

Source: EI-ASPM model: Authors' analysis.

In addition to these direct cost differences there are indirect cost differences between publishing models. Based on the cases and scenarios explored in this study we estimate that OA publishing for journal articles may bring system savings of around £213 million per annum nationally in the UK (at 2007 prices and levels of publishing activity), of which around £166 million would accrue in higher education. These savings can be set against the cost of OA publishing, which if all journal articles produced encountered author fees would have amounted to around £170 million nationally in 2007, of which £150 million would have been faced by higher education institutions. Thus the cost savings alone are likely to be sufficient to pay for OA journal publishing, independent of any possible increase in returns to R&D that might arise from enhanced access.<sup>97</sup>

<sup>97</sup> The OA self-archiving with overlay services model explored in this study is necessarily speculative, but a repositories and overlay services model may well produce greater cost savings than OA publishing.

Nevertheless, the increases in returns to R&D resulting from enhanced access are likely to be substantial. To explore the impacts of enhanced access on returns to R&D we modify the basic Solow-Swan model by introducing ‘accessibility’ and ‘efficiency’ as negative or friction variables, and then calculating the impact on returns to R&D of reducing the friction by increasing accessibility and efficiency.

We find that with a 20% social return to publicly funded R&D, for the major categories of research expenditure in the UK in 2006 a 5% increase in accessibility and efficiency would have been worth:

- £172 million per annum in increased returns to public sector R&D (*i.e.* government and higher education by sector of execution);
- £124 million per annum in increased returns to higher education R&D (HERD);
- £109 million per annum in increased returns to government R&D (GovERD); and
- Around £33 million per annum in increased returns to research councils (RCUK) competitive grants funded R&D.

These are recurring annual gains from the effect of one year’s R&D, such that if the change that brings the increases in accessibility and efficiency is permanent they can be converted to growth rate effects.

## 7.4 Comparing costs and benefits

Modelling the impacts of an increase in accessibility and efficiency resulting from more open access on returns to R&D over a 20 year period (*e.g.* from OA publishing and/or self-archiving) and then comparing costs and benefits, we find that the benefits of open access publishing models are likely to outweigh the costs (Table 7.4).

First, we explore the cost-benefit implications of simply adding OA publishing and self-archiving to current activities, all other things remaining the same (*i.e.* *ceteris paribus* scenarios); and then we explore the implications of OA publishing and self-archiving as alternatives to current activities, by adding the estimated savings to estimated returns (*i.e.* net cost scenarios).

These comparisons suggest that the additional returns to R&D resulting from enhanced accessibility and efficiency alone may be sufficient to cover the costs of parallel OA self-archiving (*i.e.* Green OA). When estimated savings are added to generate net costs there is a substantial increase in the benefit/cost ratios and for both OA publishing and self-archiving the benefits exceed the costs (even in transition).<sup>98</sup>

---

<sup>98</sup> Moreover, as noted, the system savings alone may also more than offset the costs for both OA publishing and self-archiving of journal articles in UK higher education, independent of increased returns.

Table 7.4: Summary of benefit/cost comparisons by scenario and model (GBP millions and Benefit/Cost ratio)

| <i>Scenario</i>   | <i>Costs</i> | <i>Savings</i> | <i>Benefits</i> | <i>Benefit/Cost Ratio</i> |
|---|--------------|----------------|-----------------|---------------------------|
| <b>Ceteris Paribus Scenarios</b>                            |              |                |                 |                           |
| <b><i>Transitional Model:</i></b>                           |              |                |                 |                           |
| OA Publishing in HE (unrealistic)                           | 1,787        | ..             | 615             | 0.3                       |
| OA Publishing Nationally (unrealistic)                      | 2,079        | ..             | 2,353           | 1.1                       |
| OA Repositories in HE                                       | 189          | ..             | 615             | 3.2                       |
| OA Repositories Nationally                                  | 237          | ..             | 2,353           | 9.9                       |
| <b><i>Simulated Steady State Model:</i></b>                 |              |                |                 |                           |
| OA Publishing in HE (unrealistic)                           | 1,787        | ..             | 6,876           | 3.8                       |
| OA Publishing Nationally (unrealistic)                      | 2,079        | ..             | 26,318          | 12.7                      |
| OA Repositories in HE                                       | 189          | ..             | 6,876           | 36.3                      |
| OA Repositories Nationally                                  | 237          | ..             | 26,318          | 110.8                     |
| <b>Net Cost Scenarios</b>                                   |              |                |                 |                           |
| <b><i>Transitional Model:</i></b>                           |              |                |                 |                           |
| OA Publishing in HE with direct and indirect savings        | 1,787        | 2,016          | 615             | 1.5                       |
| OA Repositories in HE with direct and indirect savings      | 189          | 2,148          | 615             | 14.6                      |
| OA Publishing Nationally with direct and indirect savings   | 2,079        | 2,575          | 2,353           | 2.4                       |
| OA Repositories Nationally with direct and indirect savings | 237          | 2,697          | 2,353           | 21.3                      |
| <b><i>Simulated Steady State Model:</i></b>                 |              |                |                 |                           |
| OA Publishing in HE with direct and indirect savings        | 1,787        | 2,016          | 6,876           | 5.0                       |
| OA Repositories in HE with direct and indirect savings      | 189          | 2,148          | 6,876           | 47.7                      |
| OA Publishing Nationally with direct and indirect savings   | 2,079        | 2,575          | 26,318          | 13.9                      |
| OA Repositories Nationally with direct and indirect savings | 237          | 2,697          | 26,318          | 122.2                     |

Note: Costs, savings and benefits are expressed in Net Present Value over 20 years, GBP millions. See modelling assumptions outlined in Section 5.

Source: EI-ASPM model: Authors' analysis.

Indicative modelling of post-transition 'steady-state' alternative systems suggests that once established alternative OA publishing and/or self-archiving systems would produce substantially greater benefits, such that:

- For UK higher education, in an alternative OA journal publishing system the benefits might be 5 times the costs, and in an alternative OA self-archiving system with commercial overlay production and review services the benefits might be more than 45 times the costs; and
- For the UK nationally, in an alternative OA journal publishing system the benefits might be 14 times the costs, and in an alternative OA self-archiving system with commercial overlay production and review services the benefits might be more than 120 times the costs.

We also explore a number of frequently asked questions (FAQs), beginning with the issue of diverting research funds to author/producer side payments for OA publishing, and then exploring the possible impacts of delayed OA (*e.g.* embargo periods) and speeding up the research and discovery process (*e.g.* self-archiving pre-prints).



Our analysis suggests that under the modelled assumptions funding agencies or institutions might be able to divert up to 3.5% of research funding to author/producer side fees before net benefits are exhausted – a level that is much higher than is commonly reported and one-and-a-half times that required (on estimated costs). Of course, this is dependent on the returns characteristic for the field of research, and returns are typically higher in medical research than elsewhere and might be expected to be lower in some areas of Humanities and the Arts. Hence, the percentage of funds at which breakeven might be reached would likely be higher for the Medical Research Council or Wellcome Trust than for Arts and Humanities Research Council, for example.

Simulating the impact of a one year ‘Delayed OA’ embargo on all journal articles, we find that over 20 years such delays reduce the estimated increases in returns to R&D by around 2% (in the transitional model) – costing the equivalent of around £120 million in lost returns to UK higher education research spending (HERD).

Simulating the impact of the potential for enhanced and/or earlier access to speed up the research and discovery process (*e.g.* through self-archiving pre-prints), we find that over 20 years speeding up the research and discovery process by one year increases the estimated increases in returns to R&D by around 3.6% (in the transitional model) – worth around £220 million in additional increases in returns to Higher Education R&D expenditure (HERD).<sup>99</sup>

## 7.5 Implications for UK Higher Education

We have inherited system of scholarly publishing that evolved over many years, primarily to serve the needs of disciplinary research in specialist institutions in a print-based environment. But, the scholarly information environment is undergoing profound change, with new technologies and new means of research communication and dissemination changing traditional publishing. At the same time, research practices are changing, with more problem oriented, multidisciplinary research being conducted in a wider range of settings, and there is increased focus on research performance, evaluation and the commercialisation of findings, with users of research in industry and elsewhere are placing new demands on the system for access and participation. As a result, higher education and research institutions are facing new demands for accountability and transparency, but there are new opportunities to record and communicate the findings of research, both between researchers and beyond to users in industry, government and non-government organisations.

### Research communication costs

Research and research communication costs are significant, with core scholarly publishing related activities in UK Higher Education probably costing some £4.8 billion per annum (excluding the costs of the research that contributes to it). Reading by those HE staff actively publishing probably cost around £2.5 billion in 2007, writing core peer reviewed scholarly publications cost around £1.5 billion, and preparing and reviewing research grant applications

---

<sup>99</sup> Both of these are sensitive to the discount rate applied.

for the research councils (RCUK), Wellcome and Leverhulme Trusts alone probably cost around £130 million. Peer review of journal articles and research monographs conducted on behalf of publishers by HE staff (*i.e.* external peer review) probably cost around £180 million during 2007, and the external journal editorial and editorial board activities of HE researchers around £60 million. We estimate that higher education output-related publisher costs probably amounted to around £515 million (excluding the external non-publisher costs noted above).

### The impacts of alternative publishing models

Our analysis of research performance and research library costs demonstrates that the efficiency of the scholarly communication system is important to UK Higher Education institutions as both producers and users of scholarly publications. Alternative scholarly publishing models imply substantial cost differences for UK Higher Education throughout the scholarly communication life-cycle.

Summing the costs of production, publishing and dissemination *per article* suggests that average per article e-only toll access publishing costs amount to around £8,296, average per article e-only OA publishing costs amount to £7,483 and average per article e-only OA self-archiving costs amount to £7,115 (including overlay review and production services and commercial margins). At these costs, OA e-only publishing would be around £813 per article cheaper than toll access, and OA self-archiving with overlay services around £1,180 cheaper.

For UK higher education, these cost differences would have amounted to savings of around £80 million per annum from a shift from toll access e-only to OA e-only publishing circa 2007, and £116 million from a shift from toll access e-only publishing to OA self-archiving with overlay services. While alternative publishing models for books (*i.e.* research monographs) are much less developed and costings more speculative as a result, similar savings would appear to be available from shifting to OA book publishing.

In addition to cost differences there are indirect cost savings from alternative publishing models. Based on the cases and scenarios explored in this study we estimate that OA publishing may bring system savings of around £213 million nationally in the UK per annum (at 2007 prices and levels of publishing activity), of which around £166 million would accrue in higher education.

### Comparing costs and benefits

These savings can be set against the costs. If all UK higher education journal article output in 2007 had been published in OA journals with author-side payments, we estimate that it would have cost around £150 million. Given that it is said that no more than half OA journals actually charge author fees, perhaps £75 million would have been required. However, if the UK supported OA publishing in proportion to output, the remaining £75 million would have been paid in other forms of institutional support.

Based on estimated repository costs, which are necessarily no more than approximate, the OA repositories in operation in the UK as of August 2008 may have involved annual costs of around £10 million. We estimate that a full system of institutional repositories in UK higher education,

in which every institution had one publications oriented repository in which all publications were self-archived once, would have cost around £20 million per annum at 2007 prices and levels of publication output.

Thus the cost savings alone are likely to be sufficient to pay for OA publishing, independent of any possible increase in returns to R&D that might arise from enhanced access.<sup>100</sup>

### Modelling the impacts of enhanced access

Modelling the impacts on returns to R&D of enhanced *accessibility* and *efficiency* resulting from more open access over a 20 year period (*e.g.* from OA publishing and/or self-archiving) and then comparing costs and benefits, we find that the benefits of open access publishing models are likely to outweigh the costs.

Our analysis suggests that the additional returns from enhanced accessibility and efficiency alone may be sufficient to cover the costs of parallel OA self-archiving (*i.e.* Green OA). When estimated savings are added to generate net costs there is a substantial increase in the benefit/cost ratios, and for both OA publishing and self-archiving the benefits exceed the costs (even during the transition).

Indicative modelling of post-transition ‘steady-state’ alternative systems suggests that once established alternative OA publishing and/or self-archiving systems would produce substantially greater benefits. For UK higher education, in an alternative OA journal publishing system the benefits might be 5 times the costs, and in an alternative OA self-archiving system with commercial overlay production and review services the benefits might be more than 45 times the costs.

---

<sup>100</sup> The OA self-archiving with overlay services model explored in this study is necessarily speculative, but a repositories and overlay services model may well produce greater cost savings than OA publishing.

## 8 Conclusions and recommendations

Any analysis of the costs and benefits of alternative scholarly publishing models faces considerable challenges. To compare the costs of alternative publishing models it is necessary to disentangle the impacts of formats (*i.e.* print versus electronic) from those of the publishing models (*i.e.* toll versus open access) throughout the scholarly communication life-cycle, and that is very difficult to do. Moreover, it is not possible to compare toll with open access publishing directly at the national level as they perform very different functions. Toll access publishing seeks to provide UK subscribers with access to worldwide research (to the limits of affordability), whereas open access seeks to provide worldwide access to UK research.

There are also major differences between impacts during a transitional period and those in a hypothetical alternative ‘steady-state’ system. Because of the lag between research expenditure and the realisation of economic and social returns to that research, impacts on returns to R&D are lagged and the value of those returns must be discounted to reflect that fact that a shift to OA publishing or self-archiving would be prospective and not retrospective, and that in a transitional period the economic value of the impacts of enhanced accessibility and efficiency would not be reflected in returns to R&D until those returns are realised. In a hypothetical alternative ‘steady-state’ system, the benefits of historical increases in accessibility and efficiency would be realised from year one, reflecting the situation after the transition has worked through and is no longer affecting returns to R&D. We took the view that it was more realistic and of more immediate concern to model the transition, but it must be emphasised that a transitional model returns significantly lower benefit/cost ratios than would a hypothetical alternative ‘steady-state’ model. Hence, while the findings presented should be interpreted with caution, the assumptions and modelling are very conservative.

### 8.1 Conclusions

The costs, benefits and impacts of alternative scholarly publishing models revealed by this analysis demonstrate that research and research communication are major activities and the costs involved are substantial. Preliminary analysis of the potential benefits of more open access to research findings suggests that returns to research can also be substantial, and that different models for scholarly publishing can make a material difference to the returns realised, as well as the costs faced.

It seems likely that more open access would have substantial net benefits in the longer term and, while net benefits may be lower during a transitional period they are likely to be positive for both OA publishing and self-archiving alternatives (*i.e.* Gold OA) and for parallel subscription publishing and self-archiving (*i.e.* Green OA). This suggests that there are gains to be realised from moving towards more open access publishing models and that, despite the lag between the costs and the realisation of benefits, the transition would probably be affordable within current system-wide budgetary allocations.

## 8.2 Recommendations

Our analysis suggests that there is evidence to support a move towards more open access to research findings, and it provides some guidance as to where the gains may be most substantial, the levels of cost and cost savings involved, and the budgetary implications for various actors in the system.

### 8.2.1 *Overcoming the barriers*

Given the potential benefits, there is scope to focus on reducing the barriers to transitioning to more cost-effective scholarly publishing models. Key areas for attention are those of creating a level playing field by enabling innovation and aligning incentive and reward systems, and raising awareness of the opportunities. This might involve:

- Ensuring that research evaluation is not a barrier to innovation (*e.g.* by developing and using metrics that support innovation in scholarly publishing, rather than relying on traditional evaluation metrics that reinforce and reward traditional publishing models and behaviours);
- Ensuring that there is funding for author or producer side fees (*e.g.* encouraging all research funders to make explicit provision for publication charges, and encouraging higher education and research institutions to establish funds to support publishing fees);
- Encouraging and funding the further development of institutional and/or subject repositories; and
- Supporting advocacy initiatives to inform and educate funders, researchers and research managers about the potential impacts of alternative publishing models.

### 8.2.2 *Realising the benefits*

The Cost savings can be realised more quickly than can increases in returns to R&D, so there is merit in making them an early focus. This might involve:

- Focusing on areas where there are cost impacts relating to the various publishing models (*e.g.* complexity and uncertainty in such areas as copyright and licensing conditions and permissions, purchasing and licensing negotiations, and the cost impacts of imposing access control and authentication systems); and
- Focusing on areas where there are cost impacts relating to the various publishing models, especially where they are likely to be substantial (*e.g.* the implications of alternative publishing models for research costs, publishing costs, research library handling and acquisitions costs, and research reporting and management costs).

Our analysis suggests that open access self-archiving, either in parallel with subscription publishing or with overlay services, may be very cost-effective, although more information is required on repository costs and the potential benefits of greater integration of publications with other forms of research output, their integration into learning materials, and the curation and

sharing of research data (Box E-I). Hence, there is scope to focus greater attention on the development of repositories. This might include:

- Encouraging and supporting the development of institutional and/or subject repositories;
- Encouraging greater focus on the operational effectiveness of repositories (*e.g.* enhancing metadata standards and quality, effective federation, enhanced discoverability and searchability, supporting the development and use of metrics and reporting suitable for research evaluation, etc.); and
- Encouraging greater sharing of information and experiences to enable stakeholders to better understand the costs and benefits involved and build more effective ‘business cases’ for repositories.

Our analysis also suggests that there may be considerable benefits available from a shift to open access scholarly book publishing. Hence, there is scope to further explore the possibilities. This might involve:

- Supporting or conducting more research into the academic book publishing value chain, where substantial costs savings and benefits appear to be available from shifts to electronic and open access publishing, but alternative publishing models are as yet more embryonic and relatively little is known about the longer term operational viability of open access scholarly book publishing; and
- Encouraging greater sharing of information and experiences of emerging open access book publishing initiatives to enable stakeholders to better understand the costs and benefits involved and build more effective ‘business cases’.

### 8.2.3 Sharing the gains

While a major contributor to the scholarly literature, the UK accounts for no more than 10% of the World’s scientific papers. Hence, international developments are of great importance in realising the benefits of more open access and much can be achieved by international efforts towards sharing the gains. This might involve:

- Encouraging and supporting greater attention to the potential benefits of more open access to research findings in international fora (*e.g.* European Commission, OECD, UNESCO, etc.); and
- Encouraging international cooperation between agencies and supporting the activities of such cooperative efforts.

### 8.2.4 Further research

There are many areas in which further information and analysis might give stakeholders greater confidence to experiment with alternative publishing models. These include:

- Encouraging and supporting the collection of better data in such areas as:

## Economic implications of alternative scholarly publishing models

- OA repository costs, impacts and operational statistics;
  - Operational information about special libraries and library related activities outside higher education; and
  - Information on the activities of users of scientific and scholarly publications and other outputs in industry, government and non-government organisations and the community at large (*e.g.* independent scholars, etc.).
- Supporting or conducting more research into areas where the greatest benefits may be available (*e.g.* the possibilities for, and potential benefits of, convergence and the integration of more open access to publications, data curation and sharing, and education and learning that is possible through repositories);
  - Supporting or conducting more research into the academic book publishing value chain, where substantial costs savings and benefits appear to be available from shifts to electronic and OA publishing, but alternative publishing models are as yet more embryonic and relatively little is known about the longer term operational viability of OA scholarly book publishing;
  - Supporting or conducting more research into alternative and emerging forms of scholarly communication, in order to understand the roles of and interactions between them, and the systemic implications of alternative publishing models and new forms of research communication in what is a rapidly changing environment; and
  - Encouraging greater integration of research relating to the conduct of R&D and operation of the S&T system with research on scholarly publishing and scholarly communication more broadly (*e.g.* research relating to Open Innovation).

\*\*\*

## List of Acronyms

|         |  |
|---------|--|
| AHRC    | Arts and Humanities Research Council, UK                             |
| AUD     | Australian Dollars   |
| BERD    | Business Expenditure on Research and Development                     |
| CNRS    | Centre National de la Recherche Scientifique                         |
| CSES    | Centre for Strategic Economic Studies, Victoria University           |
| DTI     | Department of Trade and Industry, UK                                 |
| EI-ASPM | Economic Implications of Alternative Publishing Models               |
| e-only  | Electronic format only   |
| FEC     | Full Economic Costing  |
| FTE     | Full Time Equivalent   |
| GBP     | Great Britain Pounds   |
| GDP     | Gross Domestic Product   |
| GERD    | Gross (national) Expenditure on Research and Development             |
| GNP     | Gross National Product   |
| GovERD  | Government Expenditure on Research and Development                   |
| HE      | Higher Education   |
| HEFCE   | Higher Education Funding Council, UK                                 |
| HEIs    | Higher Education Institutions  |
| HERD    | Higher Education Expenditure on Research and Development             |
| HESA    | Higher Education Statistical Agency                                  |
| HIV     | Human immunodeficiency virus   |
| IDEFO   | A modelling standard   |
| ILL     | Inter-Library Loan   |
| ISI     | Institute for Scientific Information                                 |
| IT      | Information Technology   |
| JISC    | Joint Information Systems Committee                                  |
| LISU    | Library and Information Statistics Unit, Loughborough University, UK |
| MRC     | Medical Research Council, UK   |
| NGO     | Non-Government Organisation  |
| NIH     | National Institutes of Health, US                                    |
| NSO     | National Statistical Office, UK                                      |
| OA      | Open Access  |
| OAI-PMH | Open Access Institute Protocol for Metadata Harvesting               |
| OAIR    | Open Access Institutional Repositories                               |
| OAP     | Open Access Publishing   |
| OECD    | Organisation for Economic Cooperation and Development                |
| R&D     | Research and Development   |
| RAE     | Research Assessment Exercise   |
| RCUK    | Research Councils UK   |
| REF     | Research Evaluation Framework  |
| S&T     | Science and Technology   |
| SCONUL  | Society of College, National and University Libraries, UK            |
| STM     | Science, Technical and Medical                                       |
| TRAC    | Transparent Approach to Costing                                      |
| UK      | United Kingdom   |
| UNESCO  | United Nations Educational, Scientific and Cultural Organisation     |
| URL     | Unique Resource Locator  |
| USD     | US Dollars   |
| VAT     | Value-Added Tax  |
| WoK     | ISI Web of Knowledge / Web of Science                                |



## Collected Assumptions

### Cost estimation assumptions

| <b>Parameter</b>   | <b>Basis</b>   | <b>Value</b>   |
|--|--|--|
| <b>FUND RESEARCH</b>   |  |  |
| External peer review of grant applications                       | Tenopir and King (2000) time to review a journal article                     | 3 to 6 hours each, average 5 hours   |
| Peer reviews per grant application                               | Research council consultation  | 2 to 5 per application, average 3  |
| Peer review costs, per hour                                      | UK academic salaries including on-costs and overheads, using TRAC fEC method | £40 to £93 per hour, average £56   |
| <b>PERFORM RESEARCH</b>  |  |  |
| Time to write a journal article                                  | Tenopir and King (2000), King (2004)   | 90 to 100 hours, average 95  |
| Time to peer review an article                                   | Tenopir and King (2000), King (2004)   | 3 to 6 hours, average 4.5  |
| Number of peer reviewers per article                             | Tenopir and King (2000)  | 2 to 3 reviewers, average 2.5  |
| Rejection and resubmission (article)                             | Authors' estimate  | 50% rejected of which 60% are sent for external review and 40% rejected without review, and of which 75% are resubmitted once  |
| Number of peer reviewers per monograph                           | Industry consultation  | 2 to 3 reviewers, average 2  |
| Rejection and resubmission (monograph)                           | Authors' estimate  | 20% rejected of which 50% are resubmitted once   |
| Time spent on editorial activities                               | Industry consultation  | 10 to 30 days per annum, average 20  |
| Time spent on editorial board activities                         | Industry consultation  | ½ to 1 day per year, average ¾   |
| Percentage of authors who are editors and/or on editorial boards | Rowlands and Nicholas (2005)   | 8% and 24%, respectively   |
| Number of readings per researcher per year                       | Tenopir and King (2000), tracking studies and Tenopir <i>et al.</i> (2008)   | Industry/higher education: <ul style="list-style-type: none"> <li>• Articles 130/270 rising to 280</li> <li>• Books 53/48</li> <li>• Reports 65/46</li> <li>• Trade literature 51/74</li> <li>• Other items 22/14</li> </ul> |
| Time spent reading an article                                    | Tenopir and King (2007) and Tenopir <i>et al.</i> (2008)                     | 34 minutes falling to 31, but slightly higher for research, estimate 31  |
| Time spent searching for and accessing an article                | Tenopir and King (2007), CEPA (2008) and Tenopir <i>et al.</i> (2008)        | 8 to 17 minutes, average 12.5 but falling, estimate 12.5   |
| Article requests per reading                                     | Tenopir and King (2000), CEPA (2008)   | 1.3 to 1.4   |
| Time spent by author obtaining permissions per article           | Halliday and Oppenheim (1999)  | 1 to 4 hours, average 2  |

| <b>Parameter</b>   | <b>Basis</b>   | <b>Value</b>   |
|--|--|--|
| Percentage of articles photocopied or printed                | CEPA (2008) and Tenopir <i>et al.</i> (2008)   | 20% print, 69% electronic                              |
| Cost of printing and copying per page                        | SCONUL   | 5 pence per page                                       |
| Time spent printing or copying an article                    | Authors' estimate  | 1 to 5 minutes, average 3                              |
| <b>PUBLISH JOURNALS</b>                                      |  |  |
| Pages per article  | Tenopir and King (2000) and tracking studies, CEPA (2008), King <i>et al.</i> (2008) | 11.7 to 14.3, estimate 12.4                            |
| Articles per issue   | Tenopir and King (2000), CEPA (2008)   | 10 to 20, estimate 10                                  |
| Issue per year   | Tenopir and King (2000) and tracking studies, CEPA (2008)                            | 8 to 16, estimate 12                                   |
| Articles per title per year (location of average article)    | Tenopir and King (2000) and tracking studies, Björk <i>et al.</i> (2008)             | 50 to 150, estimate 120                                |
| Non-article content pages                                    | King (2007), King <i>et al.</i> (2008)   | 10% to 20%, estimate 14%                               |
| Article rejection rate                                       | Consensus from literature  | 40% to 60%, estimate 50% (20% rejected without review) |
| Subscriptions per title                                      | Tenopir and King (2000), CEPA (2008)   | 300 to 3,000, estimate 1,200                           |
| Management and investment margin                             | CEPA (2008)  | 20% to 25%, estimate 20%                               |
| Surplus / profit margin                                      | CEPA (2008) adjusted   | 10% to 30%, estimate 20%                               |
| E-only delivery and fulfilment (relative to print)           | CEPA (2008), Waltham (2005)  | 25%  |
| E-only content processing (relative to print)                | CEPA (2008), Waltham (2005)  | 25%  |
| OA rights management (relative to toll)                      | Authors' estimate  | 20%  |
| OA user support (relative to toll)                           | Authors' estimate  | 20%  |
| 'Author-pays' marketing and support costs (relative to toll) | Authors' estimate  | 33%  |
| OA hosting (relative to toll)                                | Authors' estimate  | 50%  |
| OA management and Investment (relative to toll)              | Authors' estimate  | 75%  |
| OA surplus/profit (relative to toll)                         | Authors' estimate  | 75%  |
| <b>PUBLISH MONOGRAPHS</b>                                    |  |  |
| Pages per title  | Watkinson (2001) and industry consultation   | 250 to 300, estimate 275                               |
| Print run per title  | Watkinson (2001) and industry consultation   | 400 to 1,000, estimate 700                             |
| Sales per title  | Watkinson (2001) and industry consultation   | 350 to 500, estimate 500                               |
| Average prices   | Watkinson (2001), industry consultation and LISU                                     | £40 to £50, estimate £45                               |
| Publisher discounts (print)                                  | Industry consultation  | 20% to 40%, estimate 30%                               |

Economic implications of alternative scholarly publishing models

| <b>Parameter</b>  | <b>Basis</b>                | <b>Value</b>            |
|---|-----------------------------|-------------------------|
| Peer reviewers per manuscript                               | Industry consultation       | 2 perhaps 3, estimate 2 |
| E-only production, setting and printing (relative to print) | CEPA (2008), Waltham (2005) | 25%                     |
| E-only IT facilities (relative to print)                    | Authors' estimate           | 200%                    |
| Toll access e-only facilities (relative to print)           | Authors' estimate           | 50%                     |
| OA e-only facilities (relative to toll and print)           | Authors' estimate           | 33%                     |
| OA rights management (relative to toll)                     | Authors' estimate           | 20%                     |
| OA marketing and support costs (relative to toll)           | Authors' estimate           | 33%                     |
| OA management and overhead costs (relative to toll print)   | Authors' estimate           | 75%                     |

Source: Authors' analysis.

## Scenario assumptions

| <b>Parameter</b>   | <b>Basis</b>   | <b>Value</b>              |
|--|--|---------------------------|
| <b>FUND RESEARCH</b>   |  |                           |
| Funder operational costs as a share of funding   | UK S&T Budget document   | 3%                        |
| Evaluation and reporting as a share of operational costs   | Authors' estimate  | 50%                       |
| Potential savings in these costs from enhanced access  | Authors' estimate  | 5% to 10%, estimate 5%    |
| Returns to publicly funded R&D   | Literature review (conservative consensus from the literature)                                     | 20% to 60%, estimate 20%  |
| Improved allocations increase returns to R&D   | Authors' estimate  | 1% to 5%, estimate 2.5%   |
| Increase in allocations to R&D   | Authors' estimate  | 1% to 5%, estimate 2.5%   |
| <b>PERFORM RESEARCH</b>  |  |                           |
| Search, discovery and access time saving through more open access  | Authors' estimate  | 5% to 10%, estimate 5%    |
| Permissions time saving through more open access   | Authors' estimate  | 40% to 60%, estimate 50%  |
| Peer review time saving through more open access   | Authors' estimate  | 5% to 20%, estimate 10%   |
| Writing and preparation time saving through more open access   | Authors' estimate  | 5% to 10%, estimate 5%    |
| <b>PUBLISH</b>   |  |                           |
| UK share of worldwide scholarly publishing output (articles)   | DIUS (2007), CEPA (2008), King (2004)  | 6.6% to 9.4%, estimate 8% |
| Competition reduces publisher costs and margins  | Authors' estimate  | 5% to 10%, estimate 5%    |
| <b>DISSEMINATE</b>   |  |                           |
| Share of UK HEIs subscribing to journal titles in which UK academic authors publish ( <i>i.e.</i> duplicate subscriptions) | Authors' estimate based on total, mean and median titles subscribed to by SCONUL libraries 2006-07 | 50% to 100%, estimate 75% |

Source: Authors' analysis.

## Modelling assumptions

| <b>Parameter</b>  | <b>Basis</b>  | <b>Value</b>  |
|---|---|---|
| <b>CHANGE IN ACCESSIBILITY</b>  |   |   |
| Percentage change in accessibility (access)   | (i) 50% of the 20% of the stock of knowledge that is journals<br>(ii) 50% of the 40% of the stock of knowledge that is publications | 10% to 20%  |
| Percentage change in accessibility (OA citation)  | (i) 25% of the 20% of the stock of knowledge that is journals<br>(ii) 25% of the 40% of the stock of knowledge that is publications | 5% to 10%   |
| <i>Combined estimate of the percentage change in accessibility to be modelled</i>             | <i>Conservative consensus of the above</i>  | <i>5% to 10%, estimate 5%</i>                           |
| <b>CHANGE IN EFFICIENCY</b>   |   |   |
| Percentage change in efficiency (wasteful expenditure: duplicative research and blind alleys) | Authors' estimate, for illustrative purposes  | 1% to 5%, estimate 2%                                   |
| Percentage change in efficiency (new opportunities: collaborative opportunities)              | Authors' estimate, for illustrative purposes  | 1% to 5%, estimate 2%                                   |
| Percentage change in efficiency (speeding up the process)                                     | Authors' estimate, for illustrative purposes  | 1% to 5%, estimate 2%                                   |
| <i>Combined estimate of the percentage change in efficiency to be modelled</i>                |   | <i>5%</i>   |
| <b>R&amp;D ASSUMPTIONS</b>  |   |   |
| Social returns to R&D   | Conservative consensus from literature  | 20% to 60%, estimate 20%                                |
| Rate of growth in R&D spending  | UK National Statistical Office  | 5% per annum (current prices)                           |
| Lag between R&D spending and impacts  | Mansfield (1991, 1998)  | 3 years to publication plus 7 years to impact, 10 years |
| Discount rate (risk premium)  | Conservative consensus from literature  | 10% per annum   |
| Rate of cost increases  | Conservative estimate from CPI  | 3% per annum  |

Source: Authors' analysis.

## References

- Adams, J.D. (1990) 'Fundamental stocks of knowledge and productivity growth,' *Journal of Political Economy* 98(4), 673-702.
- Allen Consulting Group (2004) *Measuring the impact of publicly funded research*, Department of Education, Science and Training, Canberra.
- Alston, J.M. and Pardy, P.G. (2001) 'Attribution and other problems in assessing the returns to agricultural R&D,' *Agricultural Economics* 25, pp141-152.
- Altbach, P.G. and Hoshino, E.S. (1995) *International Book Publishing: An Encyclopedia*, Routledge, New York.
- Ampe, C. (2008) Commenting on the launch of BMC Research Notes. See [http://www.eurekalert.org/pub\\_releases/2008-02/bc-slo022608.php](http://www.eurekalert.org/pub_releases/2008-02/bc-slo022608.php)
- Antelman, K. (2004) 'Do open-access articles have a greater research impact?', *College & Research Libraries News*, 65(5), pp372-382 (<http://eprints.rclis.org/archive/00002309/>).
- Arms, W.Y. and Larsen, R.L. (2007) *The Future of Scholarly Communication: Building the Infrastructure for Cyberscholarship*, Workshop Report (September 2007), National Science Foundation and Joint Information Systems Committee.
- Arora, A., Fosfuri, A. and Gambardella, A. (2001) *Markets for Technology: The economics of innovation and corporate strategy*, MIT Press, Cambridge, Mass.
- Arundel, A., van de Paal, G. and Soete, L. (1995) *PACE Report: Innovation strategies of Europe's largest firms: Results of the PACE survey for information sources, public research, protection of innovations and government programmes*, MERIT, University of Limberg, Maastricht.
- Arundel, A. and Geuna, A. (2004) 'Proximity and the use of public science by innovative European firms,' *Economics of Innovation and New Technology* 3(6), pp559-580.
- Bailey, C.W. (2006) 'What is Open Access?' in Ed. Jacobs, N. (2006) *Open Access: Key strategic, technical and economic aspects*, Chandos Publishing, Oxford.
- Bailey, C.W. et al. (2006) *Institutional Repositories*, SPEC Kit 292, ARL, Washington DC.
- Bakos, Y. and E. Brynjolfsson (1999) 'Bundling information goods: Pricing, profits and efficiency', *Management Science*, 45(12), pp1613-1630.
- Bakos, Y. and E. Brynjolfsson (2000) 'Aggregation and disaggregation of information goods: Implications of bundling, site licensing, and micropayment systems', in Kahin, B. and H.R. Varian (eds.) (2000) *Internet Publishing and Beyond: The Economics of Digital Information and Intellectual Property*, The MIT Press, Cambridge and London, pp114-137.
- Bakos, Y., E. Brynjolfsson and D.G. Lichtman (1999) 'Shared information goods', *Journal of Law and Economics*, 42(4), pp117-155.

- Bazerman, C., Blakesley, D., Palmquist, M. and Russell, D. (2008) 'Open Access book publishing in writing studies: A case study,' *First Monday* 13(1), January 2008.
- Beagrie, N., Chruszcz, J. and Lavoie, B. (2008) *Keeping Research Data Safe: A cost model and guidance for UK universities*, A report by Charles Beagrie for JISC, London.
- Beckett, C. and Inger, S. (2007) *Self-Archiving and Journal Subscriptions: Co-existence or Competition?*, Publishing Research Consortium, London.
- Benhabib, J. and Spiegel, M. (1004) 'The role of human capital in economic development: Evidence from aggregate cross-country data,' *Journal of Monetary Economics* 34(2), pp143-173.
- Bergstrom, C.T. and Bergstrom, T.C. (2004) 'The costs and benefits of library site licenses to academic journals,' *PNAS* 101(3), January 2004, pp897-902.
- Bergstrom, T.C. and Lavaty, R. (2007) 'How often do economists self-archive?' (February 8, 2007). *Department of Economics, UCSB. Ted Bergstrom*. Paper 2007a. Available <http://repositories.cdlib.org/ucsbecon/bergstrom/2007a> accessed February 2008.
- Bernstein, J.I. and Nadiri, M.I. (1991) 'Product demand, cost of production, spillovers and the social rate of return to R&D,' NBER Working paper 3526.
- Björk, B-C. (2005) *Scientific communication life-cycle model, version 3.0*. (Report, 2005-02-10), Helsinki. Available <http://www.oacs.shh.fi/publications/Model35explanation2.pdf>.
- Björk, B-C. (2007) 'A model of scientific communication as a global distributed information system,' *Information Research* 12(2) paper 307. Available at <http://informationr.net/ir/12-2/paper307.html> accessed October 2007.
- Björk, B-C. and Hedlund, T. (2003) 'Scientific publication life cycle model (SPLC),' *Proceedings of the Elpub2003 Conference, From Information to Knowledge, 25-28 June 2003*, Guimaraes, Portugal. Available <http://elpub.scix.net/cgi-bin/works/Show?0317>.
- Björk, B-C. and Hedlund, T. (2004) 'A formalised model of the scientific publication process,' *Online Information Review*, 28(1), pp8-21.
- Björk, B-C. and Turk, Ž. (2000) 'How do researchers find and retrieve scientific publications – a case study of the impact of the Internet on the construction IT and construction management research communities,' *Electronic Journal of Information Technology in Construction*, 5, pp73-88. Available <http://www.itcon.org/2000/5/>.
- Björk, B-C., Hedlund, T., Holmström, J., and Cox, J. (2003) D2: Scientific Publishing: To-Be Business and Information Model. Report, SciX project, EC fifth framework programme, Information Society Technologies (IST). Available <http://www.scix.net/d/02/d2.pdf>.
- Björk, B-C., Roos, A. and Lauri, M. (2008) 'Global annual volume of peer reviewed scholarly articles and the share available via different Open Access options,' *Proceedings of ELPUB 2008*, Toronto, June 2008.
- Borgman, C. (2007) *Scholarship in the digital age: Information, infrastructure, and the Internet*. MIT Press, Cambridge.

- Boyle, J. (2007) 'The irony of a web without science,' *The Financial Times*, London, 4<sup>th</sup> September 2007. Available at <http://www.ft.com/cms/s/2/39166e30-5a7f-11dc-9bcd-0000779fd2ac.html> accessed February 2008.
- Brody T. and Harnad, S. (2005) 'Earlier Web Usage Statistics as Predictors of Later Citation Impact,' *JASIST* 57(8), pp1060-1072. Available <http://eprints.ecs.soton.ac.uk/10713/1/timcorr.htm> accessed December 2007.
- Brown, S. and Swan, A. (2007) *Researchers' Use of Academic Libraries and their Services*, A report commissioned by the Research Information Network and the Consortium of Research Libraries, London.
- CEPA (2008) *Activities, costs and funding flows in the scholarly communications system in the UK*, A report commissioned by the Research Information Network, London.
- Chan, L., Kirsop, B. and Arunachalam, S. (2005) 'Open Access Archiving: the fast track to building research capacity in developing countries,' *SciDevNet*, November 2005. Available <http://www.scidev.net/ms/openaccess/> accessed December 2005.
- Chesbrough, H. (2003) *Open Innovation: The new imperative for creating and profiting from technology*, Harvard Business School Press, Boston.
- Chesbrough, H., Vanhaverbeke, W. and West, J. (eds.) (2006) *Open Innovation: Researching a New Paradigm*, Oxford University Press, Oxford.
- CIBER (2007) *JISC National E-books User Survey*, CIBER, London. Available <http://www.ucl.ac.uk/slais/research/ciber/observatory/downloads/firstsurveyfinal.pdf> accessed June 2008.
- Clark, G.N. (2001) *Inside Book Publishing*, Routledge (Taylor and Francis), London and New York, 3<sup>rd</sup> Edition.
- Clark, G.N. (2008) *Inside Book Publishing*, Routledge (Taylor and Francis), London and New York.
- Clarke, R. (2007) 'The cost profiles of alternative approaches to journal publishing,' *First Monday* 12(12), 3 December 2007. Available <http://www.uic.edu/htbin/cgiwrap/bin/ojs/index.php/fm/article/view/2048/1906> accessed January 2008.
- Cockerill, M. (2006) 'Business models in open access publishing,' in (ed.) Jacobs, N. (2006) *Open Access: Key strategic, technical and economic aspects*, Chandos Publishing, Oxford.
- Coe, D.T and Helpman, E. (1993) *International R&D Spillovers*, NBER Working Paper 4444, National Bureau of Economic Research, Cambridge MA.
- Coles, B.R. et al. (1993) *The Scientific, Technical and Medical Information System in the UK*, British Library R&D Report No.6123.



- Competition Commission (2001) *Reed Elsevier plc and Harcourt General, Inc: A report on the proposed merger* (Cm 5186), London, July 2001 ([http://www.competition-commission.org.uk/rep\\_pub/reports/2001/index.htm](http://www.competition-commission.org.uk/rep_pub/reports/2001/index.htm)).
- Cox, J. (1998) 'The changing economic model of scholarly publishing: uncertainty, complexity and multi-media serials,' *INSPEL* 32(2), pp69-78.
- Crawford, S.Y., Hurd, J.M. and Weller, A.C. (1996) *From Print to Electronic: The Transformation of Scientific Communication*, Information Today Inc. Medford NJ.
- Creaser, C., Hamblin, Y. and Davies, J.E. (2006) An assessment of potential efficiency gains through online content use, *Program: electronic library and information systems*, 40(2): PROG 40(2), pp178-189.
- Cutler, T. *et al.* (2008) *Venturous Australia: building strength in innovation*, Cutler and Company, Melbourne.
- David, P. and Foray, D. (1995) "Assessing and Expanding the Science and Technology Knowledge Base," *STI Review*, No.16, OECD, Paris.
- Davis, C. (2004) 'Uncorrected transcript of oral evidence: Enquiry into Scientific Publications, Science and Technology Committee, House of Commons,' to be published as HC 399-i (Monday 1 March). Available at <http://www.publications.parliament.uk/pa/cm200304/cmselect/cmsctech/uc399-i/uc39902.htm> accessed March 2008.
- Davis, P., Ehling, T., Habicht, O., How, S., Saylor, J.M. and Walker, K. (2004) 'Report of the CUL Task Force on Open Access Publishing Presented to the Cornell University Library Management Team August 9, 2004', p11. Available <http://dspace.library.cornell.edu/handle/1813/193> accessed January 2005.
- Davis, P.M. (2006) 'Do Open-Access articles really have a greater research impact?' Letter to the Editor, *College & Research Libraries* 67(2), pp103-04.
- Day, C. (1998) 'Digital Alternatives: solving the problem or shifting the costs?' *Journal of Electronic Publishing*, 4(1).
- Denison, E.F. (1985) *Trends in American Economic Growth, 1929-1982*. Brookings Institution, Washington DC.
- Department for Innovation, Universities and Skills (DIUS) (2008) *UK continues to punch above its weight in world class research*, News Release 045/2008, 30 July 2008. Available at <http://nds.coi.gov.uk/environment/fullDetail.asp?ReleaseID=375598&NewsAreaID=2&NavigatedFromDepartment=False> accessed August 2008.
- DEST (Department of Education, Science and Training) (2003) *Mapping Australian Science and Innovation: Main Report*, Canberra.
- Department of Trade and Industry (DTI) (1998) *Building the Knowledge Driven Economy: Competitiveness White Paper*, Department of Trade and Industry, London.

- Department of Trade and Industry (DTI) (2007) *Measuring economic impacts of investment in the research base and innovation: a new framework for measurement*, Department of Trade and Industry, London.
- DIUS (2007) *The Allocations of the Science Budget 2008-09 to 2010-11*, Department of Innovation, Universities and Skills, London.
- Dowrick, S. and Rogers, M. (2002) 'Classical and Technological Convergence: Beyond the Solow-Swan Growth Model,' *Oxford Economic Papers* 54, pp369-385.
- Dowrick, S. (2003) *A Review of the Evidence on Science, R&D and Productivity*. Department of Education, Science and Training, Canberra.
- Dryburgh, A. (2002) *The Costs of Learned Journal and Book Publishing: a benchmarking study for ALPSP*, ALPSP, Worthing.
- EPS, et al. (2006) *UK scholarly journals: 2006 baseline report – An evidence-based analysis of data concerning scholarly journal publishing*, Research Information Network, Research Councils UK and Department of Trade and Industry. Available at <http://www.rin.ac.uk/data-scholarly-journals> accessed February 2008.
- Erraguntla, M. and Benjamin, P. (2007) *Integrated activity based costing and activity modelling*, Knowledge Based Systems Inc. Texas.
- Etzkowitz, H. and Leydesdorff, L. (eds.) (1997) *Universities and the global knowledge economy: a triple helix of university-industry-government relations*, Pinter, London.
- Evans, D. and Sezer, H. (2002) 'A time preference measure for the social discount rate for the UK,' *Applied Economics* 34, pp1925-1934.
- Fairbanks, C.M., Worthy, J. Maloch, B. Hoffman, J.V. and Schallert D.L. (eds.). *51<sup>st</sup> National Reading Conference Yearbook*. Oak Creek, Wis.: National Reading Conference.
- Fisher, J.H. (1997) 'Comparing Electronic Journals to Print Journals: Are There Savings?' Scholarly Communication and Technology Conference, The Andrew W. Mellon Foundation, Emory University, April 24-25, 1997.
- Fishwick, F., Edwards, L. and Blagden, J. (1998) *Economic implications of different models of publishing scholarly electronic journals for professional societies and other small or specialist publishers*, report to the Joint Information Systems Committee, London. Available <http://www.ukoln.ac.uk/services/elib/papers/tavistock/scholarly-journals/cranelib.html> accessed June 2008.
- Frantzen, D. (2000) 'R&D, Human Capital and International Technology Spillovers: A cross-country analysis,' *Scandinavian Journal of Economics* 102(1), pp57-75.
- Gallager, R. (2005) 'Why we need institutional repositories,' *The Scientists* 19(19), October 10, 2005, p8.
- Getz, M. (2005) *Open Scholarship and Research Universities*, Vanderbilt University. Available <http://ideas.repec.org/p/van/wpaper/0517.html> accessed September 2005.

- Gibbons, M., Nowotny, H., Limoges, C., Schwartzman, S., Scott, P. and Trow, M. (1994) *The New Production of Knowledge: The dynamics of science and research in contemporary societies*, Sage, London.
- Gorman, G.E. and Rowland, F. Eds. (2005) *International Yearbook of Library and Information Management 2004-2005: Scholarly Publishing in an Electronic Era*, Facet Publishing, London.
- Graig, I.D., Plume, A.M., McVeigh, M.E., Pringle, J. and Amin, M. (2004) *Do Open Access Articles Have Greater Citation Impact? A critical review of the literature*, Publishing Research Consortium.
- Greco, A.N. (2003) *The Book Publishing Industry*, Lawrence Erlbaum, New York.
- Greco A.N. and Wharton, R.M. (2008) *Should University Presses adopt an Open Access [Electronic Publishing] Business Model for all their Scholarly Books?*, ELPUB 2008, Toronto. Available [http://elpub.scix.net/cgi-bin/works/Show?id=149\\_elpub2008](http://elpub.scix.net/cgi-bin/works/Show?id=149_elpub2008) accessed November 2008.
- Griffith, R., Redding, S. and Van Reenen, J. (2004) 'Mapping the two faces of R&D: Productivity growth in a panel of OECD industries,' *Review of Economic Statistics* 8, pp883-895.
- Griffiths, J-M. and King, D.W. (1993) *Special Libraries: Increasing the Information Edge*, Special Libraries Association, Washington D.C.
- Griliches, Z. (1986) 'Productivity, R&D and basic research at the firm level in the 1970s,' *American Economic Review* 76, pp141-154.
- Griliches, Z. (1995) 'R&D and productivity: Econometric Results and Measurement Issues,' In Stoneman, P. (Ed.) (1995) *Handbook of The Economics of Innovation and Technological Change*. Blackwell, Oxford, pp52-89.
- Grove, A. (ed.) *Proceedings 69th Annual Meeting of the American Society for Information Science and Technology: Vol. 43*. Information Today, Medford, NJ.
- Guellec, D. and van Pottelsberghe de la Potterie, B. (2001) 'R&D and Productivity Growth: Panel data analysis of 16 OECD countries,' *OECD Economic Studies* 33, pp103-126.
- Hahn, K. L. (2008) *Research Library Publishing Services: New Options for University Publishing*, Association of Research Libraries, Washington DC. Available <http://www.arl.org/bm~doc/research-library-publishing-services.pdf> accessed April 2008.
- Hajjem, C, Harnad, S. and Gingras, Y. (2005) 'Ten-Year Cross-Disciplinary Comparison of the Growth of Open Access and How it Increases Research Citation Impact,' *IEEE Data Engineering Bulletin* 28(4), pp39-46.
- Halliday, L. and Oppenheim, C. (1999) *Economic Models of the Digital Library*, Report to UKOLN, Loughborough University.

- Hannay, T. and Spencer, H. (2008) 'Document sharing speeds up research,' *Research Information* 33, December 2007/January 2008, pp25-26. Available [www.researchinformation.info](http://www.researchinformation.info) accessed February 2008.
- Harnad, S. and Brody, T. (2004) 'Comparing the impact of open access (OA) vs. non-OA articles in the same journals', *D-Lib Magazine* 10(6), June 2004 (<http://www.dlib.org/dlib/june04/harnad/06harnad.html>).
- Harnad, S., Brody, T., Vallieres, F., Carr, L., Hitchcock, S., Gingras, Y., Oppenheim, C., Stamerjohanns, H., and Hilf, E. (2004) 'The Access/Impact Problem and the Green and Gold Roads to Open Access,' *Serials Review* 30(4) 2004. Available <http://dx.doi.org/10.1016/j.serrev.2004.09.013> accessed April 2008.
- Harrison, M. (2007) 'Valuing the future: Choosing the discount rate in cost-benefit analysis,' OPBR Cost Benefit Analysis Conference, November 2007.
- Hedlund, T., Gustafsson, T. and Björk, B-C. (2004) 'The open access scientific journal: an empirical study,' *Learned Publishing* 17(3), pp199-209, July 2004.
- Hey, A. J. G. and Trefethen, A. E. (2003) 'The Data Deluge: An e-Science Perspective', in Berman, F., Fox, G. C. and Hey, A. J. G., (eds.) *Grid Computing – Making the Global Infrastructure a Reality*, Wiley and Sons, pp809-824.
- Hickerson, T.H. (2004) *Project Euclid and the ArXiv: Complimentary and Contrasting Elements for Sustainability*, Cornell University Library, Ithaca, NY.
- Houghton, J.W. (2005a) 'Changing Research Practices and Research Infrastructure Development' *Higher Education Management and Policy*, 17(1) 2005, pp63-81, Paris.
- Houghton, J.W. (2005b) 'Economics of Publishing and the Future of Scholarly Communication' in Eds. Gorman, G.E. & Rowland, F. (2005) *International Year Book of Library and Information Management 2004-2005: Scholarly Publishing in an Electronic Era*, Facet Publishing, London; etc.
- Houghton, J.W. (2007) 'Research Communication in Australia: Emerging Opportunities and Benefits,' Paper present at The National Scholarly Communications Forum 2007: Improving Access to Australian Publicly Funded Research – Advancing Knowledge and the Knowledge Economy, Canberra, July 16, 2007.
- Houghton, J.W. and Sheehan, P.J. (2006) *The Economic Impact of Enhanced Access to Research Findings*, CSES Working Paper No.23, Victoria University, Melbourne (July 2006). Available at <http://www.cfeses.com/documents/wp23.pdf> accessed November 2007.
- Houghton, J.W. Steele, C. and Sheehan, P.J. (2006) *Research Communication Costs in Australia, Emerging Opportunities and Benefits*, Department of Education, Science and Training, Canberra. Available at <http://dspace.anu.edu.au/handle/1885/44485> accessed February 2008.

- Houghton, J.W. with Steele, C. and Henty, M. (2003) *Changing Research Practices in the Digital Information and Communication Environment*, Department of Education, Science and Training, Canberra.
- Houghton, J.W. with Steele, C. and Henty, M. (2004) 'Research Practices and Scholarly Communication in the Digital Environment' *Learned Publishing* 17(3) pp231-249, Worthing, July 2004.
- House of Representatives Standing Committee on Science and Innovation (2003) *Riding the Innovation Wave: The Case for Increasing Business Investment in R&D*, Commonwealth of Australia, Canberra.
- Hunter, K. (1998) 'Electronic Journal Publishing: Observations from the inside,' *D-Lib*, July/August 1998.
- Hurd, J.M. (1996) 'Models of Scientific Communications Systems,' in Crawford, S.Y., Hurd, J.M. and Weller, A.C. (1996) *From Print to Electronic: The Transformation of Scientific Communication*, Information Today Inc. Medford NJ, pp9.33.
- Hurd, J.M., Weller, A.C. and Crawford, S.Y. (1996) 'The Changing Scientific and Technical Communications System,' in Crawford, S.Y., Hurd, J.M. and Weller, A.C. Eds. (1996) *From Print to Electronic: The Transformation of Scientific Communication*, Information Today Inc. Medford NJ, pp97-114.
- Industry Commission (1995) *Research and Development*, Report No 44, Industry Commission, Canberra.
- Jacobs, N. (ed.) (2006) *Open Access: Key strategic, technical and economic aspects*, Chandos Publishing, Oxford.
- Jaffe, A. (1989) 'Real effects of academic research,' *American Economic Review* 79, pp957-970.
- Johnson, R.K. and Luther, J. (2008) 'Are Journal Publishers Trapped in the Dual-Media transition Zone?' *ARL: A Bimonthly Report No. 257*, April 2008.
- Jones, C.I., and Williams, J.C. (1998) 'Measuring the Social Return to R&D,' *Quarterly Journal of Economics* 113(4), pp1119-1135.
- Jubb, M., Look, H. and Sparks, S. (2007) 'Researchers' use and perceptions of discovery services,' *Learned Publishing* 20(2), pp147-153.
- Kahin, B. and H.R. Varian (eds.) (2000) *Internet Publishing and Beyond: The Economics of Digital Information and Intellectual Property*, The MIT Press, Cambridge and London.
- Kasdorf, W. (ed.) (2003) *The Columbia Guide to Digital Publishing*, Columbia University Press.
- Katz, J.S. and Hicks, D. (1997) *How much is collaboration worth? A calibrated bibliometric model*, Brighton: University of Sussex (SPRU).

- Katz, J.S. and Martin, B.R. (1997) 'What is Research Collaboration?,' *Research Policy* 26, pp1-18. Available [www.sussex.ac.uk/Users/sylvank/pubs/Res\\_col9.pdf](http://www.sussex.ac.uk/Users/sylvank/pubs/Res_col9.pdf) accessed March 2003.
- Kaufman-Wills (2005) *The facts about Open Access: A study of the financial and non-financial effect of alternative business models for scholarly journals*, ALPSP Special Report.
- KBSI (2005) *AIO WIN 8: Automated activity and ABC modelling and analysis*, Knowledge Based Systems Inc., Texas.
- Kemp, R. (2005) 'Costs of running open source institutional repositories'. Available <http://library.uncwil.edu/Faculty/kempr/listserv-summary-IR-open-source-costs.xls> accessed December 2005.
- Kenney, A.R. 'The Cornell Experience: arXiv.org,' DCC/DPC Workshop on Cost Models for Preserving Digital Assets, 26 July 2005, British Library: London.
- Kiley, R. (2007) 'Matt Cockerill's comments [Wellcome Trust and OA fees thread],' [liblicense-1@lists.yale.edu](mailto:liblicense-1@lists.yale.edu), Posted March 29, 2007.
- King, D.W. (2007) 'The cost of journal publishing: a literature review and commentary,' *Learned Publishing* 20(2), April 2007, pp85-106.
- King, D.W. and Alvarado-Albertorio, F.M. (2008) 'Pricing and other means of charging for scholarly journals: a literature review and commentary,' *Learned Publishing* 21(4), pp248-272. Available <http://dx.doi.org/10.1087/095315108X356680> accessed September 2008.
- King, D.W., Montgomery, C.H., Boyce, P. and Tenopir, C. (2003) 'Library economic measures: Examples of the comparison of print & electronic journal collections,' *Library Trends* 51(3), pp376-400.
- King, D.W., Aerni, S., Brody, F., Herbison, M. and Kohberger, P. (2004) *Comparative cost of the University of Pittsburgh electronic and print library collections*, University of Pittsburgh, May 2004.
- King, D.W. and Tenopir, C. (2004) 'An evidence-based assessment of the author-pays model', *Nature*, Web Focus: Access to the Literature. Available [www.nature.com/nature/focus/accessdebate](http://www.nature.com/nature/focus/accessdebate) accessed June 2004.
- King, D.W., Lancaster, F.W., McDonald, D.D., Roderer, N.K. and Wood, B.L. (1976) *Statistical Indicators of Scientific and Technical Information Communication (1960-1980)*, 3 Volumes, Report to the National Science Foundation C-878. King Research, Inc., Center for Quantitative Sciences (GPO 083-000-00295-3).
- King, D.W., Tenopir, C. and Clarke, M. (2006) 'Measuring total reading of journal articles,' *D-Lib Magazine* 12(10), October 2006. Available [www.dlib.org/dlib](http://www.dlib.org/dlib) accessed March 2008.
- Kingma, B.R. (2001) *The Economics of Information: A guide to economic and cost-benefit analysis for information professionals*, Libraries Unlimited, Westport.
- Kircz, J. (2005) *Institutional Repositories, a new platform in Higher Education and Research*, KRA, Netherlands.



- Kline, S., Rosenberg, N., (1986) 'An overview of innovation,' In Landau, R., Rosenberg, N. (Eds.), *The Positive Sum Strategy: Harnessing Technology for Growth*, National Academy Press, Washington DC.
- Kopak, R. and Chiang, C-N. (2006) 'Linking and Thinking: The use of typed informational relationships in aid of semantic navigation,' *ASIS&T Annual Meeting*, Austin TX, November 2006.
- Kurtz, M. and Brody, T. (2006) 'The impact loss to authors and research,' in Jacobs, N. (ed.) *Open Access: Key strategic, technical and economic aspects*, Chandos Publishing, Oxford.
- Landau, R., Rosenberg, N. (Eds.), *The Positive Sum Strategy: Harnessing Technology for Growth*, National Academy Press, Washington DC.
- Lewis, D.W. (2004) 'A demand-side view of the future of library collections,' CNI Fall 2004 Task Force Meeting. Available <http://www.cni.org/tfms/2004b.fall/> accessed August 2005.
- Lynch, C. (1993) 'The transformation of scholarly communication and the role of the library in the age of networked communication,' *Serials Librarian* 23(3-5), p20.
- Lynch, C.A. (2006) 'Open Computation: Beyond Human-Reader-Centric Views of Scholarly Literatures,' in Ed. Jacobs, N. (2006) *Open Access: Key Strategic, Technical and Economic Aspects*, Chandos Publishing, Oxford, pp185-193.
- Lyon, L. (2007) *Dealing with Data: Roles, rights, responsibilities and relationships*, UKOLN, Bath. Available [http://www.ukoln.ac.uk/ukoln/staff/e.j.lyon/reports/dealing\\_with\\_data\\_report-final.pdf](http://www.ukoln.ac.uk/ukoln/staff/e.j.lyon/reports/dealing_with_data_report-final.pdf) accessed December 2007.
- Mansfield, E. (1991) 'Academic research and industrial innovation,' *Research Policy* 20(1), pp1-12.
- Mansfield, E. (1998) 'Academic research and industrial innovation: an update of empirical findings,' *Research Policy* 26, pp773-776.
- Martin, B.R., Salter, A., Hicks, D., Pavitt, K., Senker, J., Sharp, M. and von Tunzelmann, N. (1996) *The Relationship between Publicly Funded Basic Research and Economic Performance*, A SPRU Review, HM Treasury, London.
- Martin, B.R. and Tang, P. (2007) *The benefits of publicly funded research*, SWEPS Paper No. 161, Science Policy Research Unit, University of Sussex, Brighton. Available <http://www.sussex.ac.uk/spru> accessed October 2007.
- Maynard, S. and Davies, J.E. (2001) *The Cost of Copyright Compliance in Further and Higher Education Institutions*, LISU, Loughborough.
- Montgomery, C.H. (2000) 'Measuring the Impact of an Electronic Journal Collection on Library Costs: A Framework and Preliminary Observations,' *D-Lib Magazine* 6(10). Available <http://www.dlib.org/dlib/october00/montgomery/10montgomery.html> accessed April 2008.

- Montgomery, C.H. and King, D.W. (2002) 'Comparing Library and User Related Costs of Print and Electronic Journal Collections: A First Step Towards a Comprehensive Analysis,' *D-Lib Magazine* 8(10), October 2002. Available <http://www.dlib.org/dlib/october02/montgomery/10montgomery.html> accessed April 2008.
- [Nature Editorial: May 2007] 'The use of electronic laboratory notebooks should be supported by all concerned,' *Nature* 447, pp1-2, 3 May 2007. Available <http://www.nature.com/nature/journal/v447/n7140/full/447001b.html> accessed February 2008.
- Newbery, D. and Bently, L. (2008) *Models of Public Sector Information Provision via Trading Funds*, Department for Business, Enterprise and Regulatory Reform (BERR) and HM Treasury. Available <http://www.tinyurl.com/2xs4qj> accessed March 2008.
- Newman, M. and Fearn, H. (2008) 'How much are you worth?' Times Higher Education, 13 March 2008, *The Times*, London.
- Nicholas, D., Huntington, P. and Jamali, H.R. (2007) 'Open Access in context: a user study,' *Journal of Documentation* 63(6), pp853-878.
- Nilsen, K. (2007) *Economic theory as it applies to Statistics Canada: A review of the literature*, Statistics Canada, Toronto.
- NIST (1993) *Integration definition for functional modelling (IDEF0)*, Draft Federal Information Processing Standards Publication 183, 21<sup>st</sup> December 1993, Washington DC.
- Normann, R. and Ramírez, R. (1993) 'From value chain to value constellation: Designing interactive strategy' *Harvard Business Review* 71(4) July/August 1993, pp65-77.
- NSO (2007) *Gross expenditure on research and development 2005*, National Statistics, London.
- Odlyzko, A. (1998) 'The economics of electronic publishing,' *Journal of Electronic Publishing*, 4(1). Available <http://quod.lib.umich.edu/cgi/t/text/text-idx?c=jep;view=text;rgn=main;idno=3336451.0004.106> accessed June 2008.
- OECD (1997) *National Innovation Systems*, OECD, Paris. Available at <http://www.oecd.org/dataoecd/35/56/2101733.pdf> accessed February 2008.
- OECD (2005) *Digital Broadband Content: Scientific Publishing*, OECD, Paris. Available at <http://www.oecd.org/dataoecd/42/12/35393145.pdf> accessed February 2008.
- OECD (2007) *OECD Science, Technology and Industry Scoreboard 2007: Innovation and Performance in the Global Economy*, OECD, Paris.
- Office of Fair Trading (2002) *The market for scientific, technical and medical journals*, OFT 396, London, September 2002 (<http://www.offt.gov.uk/NR/rdonlyres/A56C7602-C0BD-428D-BED2-36784363243B/0/oft396.pdf>).
- OSI e-Infrastructure Working Group (undated) *Developing the UK's e-infrastructure for science and innovation*, NESC, Edinburgh, p11. Available <http://www.nesc.ac.uk/documents/OSI/index.html> accessed January 2008.



- OTA (1986) *Research Funding as an Investment: Can We Measure the Returns?* Office of Technology Assessment, Washington DC.
- Page, G., Campbell, R. and Meadows, A.J. (1997) *Journal Publishing*, Cambridge University Press.
- Pinfield, S. (2007) 'Can open access repositories and peer reviewed journals co-exist?' *Serials* 20(3), pp163-171, November 2007. Available <http://eprints.nottingham.ac.uk/706/> accessed December 2007.
- PIRA International (2003) *The EU Publishing Industry: An assessment of competitiveness*, European Commission, Brussels.
- Piwowar, H. (2008) 'A review of journal policies for sharing research data,' ELPUB 2008: Open Scholarship: Authority, Community and Sustainability in the Age of Web 2.0, Toronto.
- Productivity Commission (2007) *Public support for science and innovation*, Productivity Commission, Canberra.
- Prosser, D.C. (2005) *The Next Information Revolution – How Open Access will Transform Scholarly Communications*, in Gorman, G.E. and Rowland, F. Eds. (2005) *International Yearbook of Library and Information Management 2004-2005: Scholarly Publishing in an Electronic Era*, Facet Publishing, London, pp99-117.
- Regazzi, J. (2004) 'The shifting sands of open access publishing: A publisher's view,' *Serials Review* 34, pp275-280.
- Rightscom (2007) *Research Funders' Policies for the management of information outputs*, Research Information Network, London. Available <http://www.rin.ac.uk/policy-information-outputs> accessed December 2007.
- Rowland, F. (2007) *The Peer Review Process: A report to the JISC Scholarly Communications Group*, JISC, London.
- Rowlands, I. and Nicholas, D. (2005) *New Journal Publishing Models: An international survey of senior researchers*, CIBER report.
- Salo, D. (2006) 'Open Access for teachers,' paper presented at HigherEdBlogCon 2006. Available <http://www.higheredblogcon.com/index.php/open-access-for-teachers/> access January 2008.
- Salter, A.J. and Martin, B.R. (2001) 'The economic benefits of publicly funded basic research: a critical review,' *Research Policy* 30(3), pp509-532.
- Schonfeld, R.C., King, D.W., Okerson, A. and Fenton, G.E. (2004a) *The non-subscription side of periodicals: changes in library operations and costs between print and electronic journals*, Council on Library and Information Resources, Washington DC.
- Schonfeld, R.C., King, D.W., Okerson, A. and Fenton, G.E. (2004b) 'Comparison of non-subscription costs of print and electronic formats on a life-cycle basis,' *D-Lib Magazine* 10(1) January 2004.

- Schwarz, G.J. and Kenicutt, R.C. (2004) 'Demographic and citation trends in astrophysical journal papers and preprints, *Bulletin of the American Astronomical Society* 36, pp1654-1663.
- SCONUL (2008) *Statistics Tables*, SCONUL, London.
- Scott, A., Steyn, G., Geuna, A., Brusoni, S. and Steinmueller, E. (2002) *The Economic Returns to Basic Research and the Benefits of University-Industry Relationships*. Report to the Office of Science and Technology, London.
- Shanks, S. and Zheng, S. (2006) *Econometric modelling of R&D and Australia's productivity*, Staff Working Paper, Productivity Commission, Canberra.
- Shirrell, R. (1997) 'Comments: Economics of Electronic Publishing: Costs Issues,' Scholarly Communication and Technology Conference, The Andrew W. Mellon Foundation, Emory University, April 24-25, 1997.
- Simboli, B. (2005) 'Subscription subsidized open access and the crisis in scholarly communication,' Lehigh University.
- Smith, J.W.T. (1999) 'The Deconstructed Journal, a new model for Academic Publishing,' *Learned Publishing* 12(2), pp79-91.
- Smith, J.W.T. (2005) Open Access Publishing Models: Reinventing Journal Publishing, *Research Information*, May-June 2005.
- Smith, K. and Thompson, P. (2008) 'The Inexorable March to Online-Only Journal Subscriptions: Varied Criteria, Unexpected Ramifications, and Coping Strategies,' *Electronic Resources & Libraries* 2008, Atlanta. Available <http://www2.sewanee.edu/its/pthompson/erl08> accessed March 2008.
- Solow, R.M. (1957) 'Technical Change and the Aggregate Production Function,' *Review of Economics and Statistics* 39, pp312-320.
- Solow, R.M. (1987) Growth Theory and After. *R.M. Solow – Prize Lecture*, Nobel e-Museum Laureates.
- Sowden, P. (2007) *University Library Spending on Books, Journals and Electronic Resources*, The Publishers Association, London.
- Sparks, S. (2005) *JISC Disciplinary Differences Report*, Rightscom, London.
- Spiller, D., Creaser, C., and Murphy, A., (1998) *Libraries in the Workplace*, LISU, Loughborough.
- SQW (2004) *Costs and business models in scientific research publishing*, The Wellcome Trust.
- Steele, C. (2008) 'Scholarly Monograph Publishing In The 21<sup>st</sup> Century. The Future More Than Ever Should Be An Open Book,' *Journal of Electronic Publishing* 11(2).
- Stevens-Rayburn, S. (2003) *ASTRO: report from the AAS Publications Board meeting*, November 2003 (<http://listserv.nd.edu/cgi-bin/wa?A2=ind0311&L=pamnet&F=&S=&P=1632>).

- Suber, P. (2007a) *Open Access Overview*. Available at <http://www.earlham.edu/~7Epeters/fos/overview.htm#journals> accessed February 2008.
- Suber, P. (2007b) 'Trends Favouring Open Access,' *CTWatch Quarterly*, August 2007.
- Suber, P. (2008) 'Open Access and quality,' *DESIDOC Journal of Library and Information Technology*, 28(1), January 2008, pp49-56. Available <http://publications.drdo.gov.in/ojs/index.php/djlit/article/viewFile/249/109> accessed June 2008.
- Swan, A. (2005) *Open Access Self-Archiving: An Introduction*, Key Perspectives, Truro.
- Swan, A. (2007) 'Open Access and the Progress of Science,' *American Scientist* 95, May-June 2007, pp198-200.
- Swan, A. (2008a) 'The business of digital repositories,' in (eds.) Weenink, K., Waaijers, L. and van Godtsenhoven, K. *A DRIVER's Guide to European Repositories*, Amsterdam University Press.
- Swan, A. (2008b) *Key Concerns within the Scholarly Communication Process*, Report to JISC, Key Perspectives, Truro.
- Swan, A. and Brown, S. (2005) *Open Access self-archiving: An author study*, Key Perspectives, Truro.
- Swan, A. and Needham, P. (2005) 'Developing a model for e-prints and open access journal content in UK further and higher education,' *Learned Publishing* 18(1), pp25-40.
- Swan, A. et al. (2004) *Delivery, Management and Access Model for E-prints and Open Access Journals within Further and Higher Education*, EPIC & Key Perspectives.
- Tenopir, C. (2005) *The role of publishing in the research process*, JISC International Colloquium, International Solutions for the Dissemination of Research: Considering international solutions for purchasing electronic journals and disseminating research outputs, London. Available [http://www.jisc.ac.uk/index.cfm?name=event\\_international\\_0605](http://www.jisc.ac.uk/index.cfm?name=event_international_0605) accessed December 2005.
- Tenopir, C. and King, D.W. (2000) *Towards Electronic Journals: Realities for Scientists, Librarians and Publishers*, Special Libraries Association, Washington D.C.
- Tenopir, C. and King, D.W. (2002) 'Reading behavior and electronic journals,' *Learned Publishing* 15(4), pp259-265.
- Tenopir, C. and King, D.W. (2007) 'Perceptions of value and value beyond perceptions: measuring the quality and value of journal article readings,' *Serials* 20(3), pp199-207. Available <http://www.uksg.org/serials> accessed July 2008.
- Tenopir, C., King, D.W., Edwards, S. and Wu, L. (forthcoming) 'Use of Scholarly Journals and Articles by University Faculty: Changes in Information Seeking and Reading Patterns over Nearly Three Decades,'.

- Terry, R. (2006) 'Text mining of subject archives will enable new facts to be discovered,' *Research Information*, June/July 2006. Available [http://www.researchinformation.info/features/issue.php?issue\\_id=4](http://www.researchinformation.info/features/issue.php?issue_id=4) accessed November 2007.
- Terry, R. and Kiley, R. (2006) 'Open Access to the research literature: a funders perspective,' in Ed. Jacobs, N. (2006) *Open Access: Key strategic, technical and economic aspects*, Chandos Publishing, Oxford.
- Tewksbury, J.G., Crandall, M.S. and Crane, W.E. (1980) 'Measuring the Societal Benefits of Innovation,' *Science* 209(4457), pp658-662.
- The National Academies (2004) *Electronic Scientific, Technical and Medical Publishing and its Implications*, The National Academies Press, Washington DC. Available <http://www.nap.edu> accessed September 2004.
- Thompson, J.B. (2005) *Books in the Digital Age*, Polity Press, Cambridge.
- Toole, A (1999) 'The impact of federally funded basic research on industrial innovation: Evidence from the pharmaceutical industry,' Stanford Institute for Economic Policy Research, Stanford CA.
- Universities UK (2007) *Publishing research results: the challenges of open access*, UUK Policy Briefing, Universities UK, London, April 2007.
- Vakkari, P. (2006) 'Trends in the use of digital libraries by scientists in 2000-2005: A case study of FinELib,' In Grove, A. (ed.) *Proceedings 69th Annual Meeting of the American Society for Information Science and Technology: Vol. 43*. Information Today, Medford, NJ.
- Van de Sompel, H. *et al.* (2004) 'Rethinking Scholarly Communication: Building the system that scholars deserve,' *D-Lib Magazine* 10(9) September 2004.
- Verspagen, B. (2004) *The Impacts of Academic Knowledge on Macroeconomic Productivity Growth: An Exploratory Study*, Eindhoven Centre for Innovation Studies, Eindhoven.
- Walsh, J.P., and Maloney, N.G. (2001) 'Computer Network Use, Collaboration Structures and Productivity.' In P. Hinds and S. Kiesler, (eds.) *Distributed work*, Cambridge, MA: MIT Press. Available <http://tigger.uic.edu/~jwalsh/Collab.html> accessed October 2008.
- Waltham, M. (2005) *JISC: Learned Society Open Access Business Models*, JISC June 2005.
- Waltham, M. (2006a) 'Learned society business models and open access: overview of a recent JISC funded study' *Learned Publishing* 19(1), January 2006, pp15-30.
- Waltham, M. (2006b) 'Learned Society business models and Open Access,' in Ed. Jacobs, N. (2006) *Open Access: Key Strategic, Technical and Economic Aspects*, Chandos Publishing, Oxford.
- Ware, M. (2006) *ALPSP Survey of Librarians on Factors in Journal Cancellation*, ALPSP, Worthing.

- Wasserman, M. (1997) How Much Does It Cost to Publish a Monograph and Why? Presentation at The Specialized Scholarly Monograph in Crisis: Or How Can I Get Tenure If You Won't Publish My Book?, 11-12 September 1997, Washington D.C. Available <http://www.arl.org/> accessed October 2008.
- Watkinson, A. (2001) *Electronic Solutions to the Problems of Monograph Publishing*, The Council for Museums, Archives and Libraries, London.
- Weenink, K., Waaijers, L. and van Godtsenhoven, K. (2008) *A DRIVER's Guide to European Repositories*, Amsterdam University Press.
- Wheatley, P., Ayris, P., Davies, R., McLeod, R. and Shenton, H. (2007) 'LIFE: costing the digital preservation lifecycle,' iPRES Annual Conference, 10 October 2007, Beijing, China. See the LIFE Project Website at <http://www.life.ac.uk>
- Willinsky, J. (2003) 'Open Access: Reading (research) in the age of information., In: Fairbanks, C.M., Worthy, J. Maloch, B. Hoffman, J.V. and Schallert D.L. (eds). *51<sup>st</sup> National Reading Conference Yearbook*. Oak Creek, Wis.: National Reading Conference, pp. 32–46. Available <http://pkp.sfu.ca/node/460>, accessed January 2007.
- Willinsky, J. (2003) 'Policymakers' online use of academic research,' *Education Policy Analysis Archives*, 11(2). Retrieved January 2008 from <http://epaa.asu.edu/epaa/v11n2/>.
- Willinsky, J. (2007) *Ensuring a Journal's Economic Sustainability While Increasing Access to Knowledge*, Public Knowledge Project, Simon Fraser University, Vancouver. Available <http://pkp.sfu.ca/node/687> accessed January 2008.
- Worlock, K. (2004) 'The pros and cons of Open Access,' *Nature Access Debate*. Available <http://www.nature.com/nature/focus/accessdebate/34.html> accessed February 2008.
- Yamey, G. (2006) Three Open Access Anecdotes, posted to SPARC-OAForum 21 March 2006 (<https://mx2.arl.org/Lists/SPARC-OAForum/Message/2876.html>).