

ED 031 998

HE 001 068

By-Boruch, Robert F.

Educational Research and the Confidentiality of Data.

American Council on Education, Washington, D.C. Office of Research.

Report No-ACE-RR-Vol-4-No-4-69

Pub Date 69

Note-53p.

EDRS Price MF-\$0.25 HC-\$2.75

Descriptors-Computer Storage Devices, \*Confidential Records, \*Data Analysis, Data Collection, Higher Education, \*Information Systems, \*Longitudinal Studies, \*Research Problems, Student Records

Identifiers-\*ACE Data Bank

The information system of the American Council on Education (ACE), which comprises the basis for the ACE Higher Education Data Bank, is designed to collect and maintain biographical and other data on approximately 300,000 college freshmen each year for continuing longitudinal research based on subsamples of the students. The need for confidential processing of these data has stimulated increasing concern among psychologists, sociologists, statisticians, administrators, and educational researchers. This study was implemented in order to set forth some limitations and problems involved with this kind of research. The report examines some specific aspects of the privacy issue with respect to ACE's information system, and the major differences and similarities between the ACE Data Bank and other data bank systems. A major emphasis is placed on evaluating devices that would help to preserve the confidentiality of data at each level of the system: data collection, transmission, and analysis dissemination. The report also discusses current administrative and ethical regulations, and computer devices that could protect researchers and the privacy of students in the event of possible harassment or liabilities caused by legal agencies.

(HM)

ED031998



**EDUCATIONAL RESEARCH  
AND  
THE CONFIDENTIALITY OF DATA**

**ROBERT F. BORUCH**

**U.S. DEPARTMENT OF HEALTH, EDUCATION & WELFARE  
OFFICE OF EDUCATION**

**THIS DOCUMENT HAS BEEN REPRODUCED EXACTLY AS RECEIVED FROM THE  
PERSON OR ORGANIZATION ORIGINATING IT. POINTS OF VIEW OR OPINIONS  
STATED DO NOT NECESSARILY REPRESENT OFFICIAL OFFICE OF EDUCATION  
POSITION OR POLICY.**

**OFFICE OF RESEARCH  
AMERICAN COUNCIL  
ON EDUCATION**

*HE 08 / 058*

**American Council on Education**

*Logan Wilson, President*

The American Council on Education, founded in 1918, is a *council* of educational organizations and institutions. Its purpose is to advance education and educational methods through comprehensive voluntary and cooperative action on the part of American educational associations, organizations, and institutions.

The Council's Office of Research was established in 1965 to assume responsibility for conducting research on questions of general concern to higher education. *ACE Research Reports* are designed to expedite communication of the Office's research findings to a limited number of educational researchers and other interested persons.

**ACE RESEARCH ADVISORY COMMITTEE**

**Nicholas Hobbs, *Chairman***  
Provost of Vanderbilt University  
and Director of the Kennedy  
Center, Peabody College

**Allan M. Cartter**  
Chancellor  
New York University

**Richard C. Gilman**  
President  
Occidental College

**John G. Darley**  
Chairman  
Department of Psychology  
University of Minnesota

**Ralph W. Tyler**  
Director Emeritus  
Center for Advanced Study  
in the Behavioral Sciences

**N. L. Gage**  
Professor of Education and  
Psychology  
Stanford Center for Research  
and Development in Teaching  
Stanford University

**Dael Wolfle**  
Executive Officer  
American Association for the  
Advancement of Science

Additional copies of this *Research Report* (Vol. 4, No. 4, 1969) may be obtained from The Office of Research, American Council on Education, 1785 Massachusetts Avenue, N.W., Washington, D.C. 20036.

## Abstract

### Educational Research and the Confidentiality of Data<sup>1</sup>

R. F. Boruch

American Council on Education

The maintenance of the confidentiality of student information has recently been a major concern among educational researchers and administrators. In this paper, the privacy issue is examined with respect to the information system which comprises the basis for the ACE Higher Education Data Bank. The system's functions are the acquisition of biographical and other data on approximately 300,000 college freshmen annually and continuing longitudinal research based on subsamples of these students.

A brief overview of the relevant literature is provided. Broad differences and similarities of the ACE Data Bank and other environments are examined. Particular attention is devoted to evaluating devices for maintenance of confidentiality at each level of the information system: data collection, transmission, and analysis dissemination. The administrative and ethical regulations now in operation, and the computer devices appropriate for preserving respondents' privacy are evaluated at each level of the system. Protection for the respondent and the researcher are discussed briefly in the context of extralegal harassment and liabilities. Recommendations and a partial statistical resolution to the "potential intelligence system" are offered.

---

<sup>1</sup> Partial support for this research was provided by NIMH Grant NM17084-01, A. W. Astin, Sponsor. The views expressed are not necessarily those of the sponsoring agency.

Contents

	<u>Page</u>
<b>I. Introductory Comments</b>	
A. American Council on Education: A Brief Description...	5
B. The Privacy Issue.....	7
C. Some Examples of Difficulty.....	11
<b>II. ACE Policy and Procedures</b>	
A. Policy Statements and Advisory Committees.....	15
B. Administrative Policy and Procedures.....	18
C. Current Problems and Alternative Solutions.....	24
1. Administration.....	24
2. Data Processing.....	27
3. ACE Office of Research Operations.....	29
4. Observations on the Legal Environment.....	33
5. Some Research Possibilities.....	38
<b>III. Figures</b>	
A. Figure 1. Information Flow and Environments.....	41
B. Figure 2. Link File Creation.....	42
C. Figure 3. Merge Process.....	42
D. Figure 4. Schematic Chart: No Access Data Merge....	43
<b>IV. Appendix A: 1968 Student Information Form</b>	

## Educational Research and the Confidentiality of Data<sup>1</sup>

R. F. Boruch

American Council on Education

The maintenance of confidentiality in research on student populations has recently been a major concern among educational researchers. Professional organizations of psychologists, sociologists, statisticians and administrators have devoted increasing attention to the issues and have provided useful general commentary on the privacy question in research.

In this paper, more specific aspects of the privacy issue are examined with respect to the information system comprising the basis for the ACE Data Bank. The function of the system is annual acquisition and maintenance of biographical and other data on a large representative sample of college freshmen. Research derived from such data is helpful in assessment of college impact on students (and vice versa) and examination of factors important in attrition rates, achievement and development of students.

A brief overview of relevant literature is provided for those who are unfamiliar with the general topic. The description includes enumeration of professional organization interests in the privacy issue. Major differences and similarities of the ACE Data Bank to other data bank systems are also examined. A major emphasis is placed on evaluating devices which enhance maintenance of confidentiality at each level of the information system: data collection, transmission, and analysis dissemination. The

---

<sup>1</sup> Partial support for this research was provided by NIMH Grant NM17084-01. The writer is indebted to Dr. A. W. Astin and Dr. John Caffrey for their comments and suggestions, and to Laura Kent for her editorial assistance.

administrative and ethical regulations now in operation, and computer devices appropriate for preserving the respondent's privacy are examined. Protection for the respondent and researcher are discussed briefly in the context of extralegal harassment and liabilities.

This study was initiated in order to better understand the limitations and problems inherent in the kind of research considered here. The solutions proposed are not to be interpreted as models, nor should they be considered the only alternatives. The examination does furnish a primitive basis for strengthening the basic ties between guarantees for individual privacy and the acknowledgement of society's need to know itself through social research.

### The American Council on Education: A Brief Description

The American Council on Education is a nongovernmental council whose membership includes nearly 1,500 colleges and universities, national and regional education associations, public and private school systems, and similar educational and professional organizations. The Council's purpose is to facilitate cooperation and coordination among these members in the interests of improving the educational processes, particularly in higher education. Separate commissions of the Council deal with relations between the Federal government and educational institutions, academic affairs, academic administration, and international education; among their primary objectives are the acquisition, interpretation, and dissemination of information relevant to the educational enterprise.

The Council's sources of finance are dues from institutional members and grants from private foundations, government agencies, and learned and professional societies. Office of Research activities are supported primarily through such dues, and secondarily by grants for specific studies from the National Institute of Mental Health and the National Science Foundation.

Within the Council, the Office of Research carries a major responsibility for conducting research on the higher education process. Insofar as the research programs frequently require that students be identified, the Office of Research is deeply concerned with maintaining the confidentiality of data. The necessity for identification becomes apparent when one is aware of the objectives of these programs; therefore, current large-scale studies to explore important phenomena in college and university environments are described briefly in the following section.



### Cooperative Institutional Research Program

The major ongoing project of the Office of Research is the Cooperative Institutional Research Program, a long-range longitudinal study of student development. Biographical, attitudinal, and environmental attributes, as reported by students, are categorized according to sex, type of institution, and geographic region. Identifying information is solicited in order to permit followup studies designed to assess what impact different institutions have on student development. The data are used for constructing normative reports, which can be used to make quantitative comparisons among geographic regions, different types of institutions, and so forth. The research reports based on these data have covered such topics as the factors that influence college dropout rates, the personal and environmental determinants of career choice, and the systematic prediction of manpower supply and demand within specific disciplines.

### Black Students in American Colleges

This research is directed toward a description of the changing size and nature of the black student population in a large representative sample of American colleges. Among the specific topics currently being investigated are the black student's attitudes, aspirations, biographical attributes, and sources of financial aid, relative to the white student's. These comparisons, both within and between types of institutions, can be used then as a base for policy decisions.

### Programs for Disadvantaged Students

This recently initiated study, which draws on current ACE data, is a program of evaluative research on aid to disadvantaged college students. Aid includes financial support in the form of loans, scholarships, etc.,

as well as on campus tutorial and counseling services. Its objectives are to document aid programs, to evaluate their relative effectiveness, and to explore alternative strategies for effective utilization of the resources of the college, the students, and the community. The basic data comprises student information acquired through the Cooperative Institutional Research Program. Followup studies and surveys of students in such programs will also be conducted.

### Campus Unrest

In addition to data from a national sample of 300 institutions in the Council's Cooperative Institutional Research Program, this study will be based on detailed case-study and interview material from approximately 30 of the campuses. Among the questions the study seeks to answer are: What is the frequency and extent of campus unrest in American higher education? What are the current trends, and what do they suggest about the immediate future? What accounts for differences among institutions with respect to the frequency and severity of the protests that occur? Do administrative practices, size, or type of institution play important roles? Are there particular administrative arrangements which tend either to provoke protest activity or to affect the course of protest once it begins? What impact do various types of demonstrations or confrontations have on the college environment?

### The Privacy Issue

Preserving the confidentiality of data has recently been the subject of much discussion and not a little controversy; numerous articles, both expository and argumentative--i.e., critical or defensive of current policies--have appeared in professional journals and in the popular press.

For example, Westin's (1967) discussion of a wide variety of situations in which the privacy of the individual may be jeopardized represents a scholarly treatment of the question. A presidential panel on privacy and behavioral research (Science, 1967) has emphasized the joint responsibilities of the researcher, his institution, and the agency sponsoring research in minimizing jeopardy to privacy. Major emphasis is placed on understanding methods for protecting individual rights, and the necessity for multidisciplinary assessment of problems. More recently, the proposal for a National Data Bank (e.g., Dunn, 1967; Sawyer and Schecter, 1968) has led legislators, institutional researchers, and professional computer scientists to give serious attention to the implications of such a project. Most of these discussions, however, concern data collection installations which function not as research bases primarily, but as a source of information for evaluation: That is, a person's records can be accessed and used to form specific judgments about him. These judgments may involve his employment capability, his academic ability as reflected in test scores, and other administrative or judicial criteria. If they are to be used on a regular administrative basis, the records must be highly reliable and must identify the individual.

In general, longitudinal research in higher education has neither the same function nor the same requirement for reliability. Usually, regular identification of the individual is unnecessary. Instead, the researcher's primary objective in eliciting information is to explore student development. Unambiguous conclusions about this development are possible only if the researcher can follow the student's progress by merging records available at different points in time. The function of this access to records is not evaluative with respect to the single individual. These functional

distinctions, though they may seem gratuitous, are of paramount importance in defining and dealing with hazards to the privacy of persons who participate in this type of research.

Because of the numbers of persons involved and the potential hazards that could result from misuse of data, the issue should be of deepest concern to the educational community. The Carnegie Commission Report (1968) suggests that the records of more than 820,000 college students are being used for research requiring some identification capability; this estimate does not include small and single-instance studies, followup studies currently being planned, or longitudinal research on primary and secondary school students.

Major concern about the issue has been given formal expression at a number of recent professional conferences. For example, at the 1968 American Personnel and Guidance Association meetings, a symposium, which included representatives of the American Council on Education, the Educational Testing Service, the National Opinion Research Center, and the National Merit Scholarship Corporation, addressed itself to confidentiality of data. Astin (1968) and Nichols (1968) provided a rationale for the conduct of longitudinal research in general. Specification of respondent rights in the survey environment was examined by Peterson (1968). Bradburn (1968) explored the administrative problems inherent in making research data available to the community of researchers. The APGA symposium is but one example. Other conferences, the proceedings of which have been published, have also manifested concern with the problem. Of particular note (though not directly related to <sup>U</sup>survey research) are the discussions of the National Council on Measurement in Education (see especially Willingham, 1967).

Currently, psychological and educational researchers have been giving considerable attention to the "ethical lag" (Hoch, 1967) which results in part from the rather recent development of the social and legal status of the right to privacy of personality. The belated recognition by interested professionals and society at large that this right must be balanced against the need for information which can enhance the well-being of society has prompted more intense examination of the legal and ethical situation. The American Educational Research Association has formed a standing committee, currently directed by Dr. Lyle Schoenfeldt, which will document and evaluate alternative approaches to existing problems arising from this issue.<sup>2</sup> The American Psychological Association (1969) has initiated revision of its current professional code of ethics. Updating the code will be based upon surveys of APA membership. This appears to be the only current large-scale effort to systematically obtain information relevant to ethical problems.

Most previous discussions of the topic have confined themselves to justifying research and endorsing codes of ethics to meet major problems. Moreover, they are usually addressed to the community of respondents and to researchers within a specific substantive area, rather than to all. Rarely do they specify methods for systematically assessing data collection procedures relevant to safeguarding the confidentiality of data; what recommendations are offered are frequently gratuitous. Ethical codes are embraced, but no procedure for implementing these codes is presented.

This paper is intended to clarify some of these issues and to provide a meaningful approach to solving the problems. Using, in part, a systems analytic approach, I have attempted to describe the total information collection and analysis survey scheme that operates in research

---

<sup>2</sup> This paper is, in part, a result of the writer's membership on the committee.

programs at the ACE Office of Research. Various environments within the scheme, and the communities of groups concerned with the issues are considered in detail.

A vigorous examination of this sort is required for two major reasons. First, longitudinal research on various groups in the population has become an increasingly important part of the total social science effort. Some mode of identifying individuals is necessary for the sake of accounting alone. Insofar as this presents some hazard to the respondent's privacy, it is essential that researchers give attention to the confidentiality issue. Second, much current longitudinal research focuses on social phenomena that often involve controversy. Insofar as that controversy results from the behavior of the persons under study, their personal privacy may be jeopardized and the researcher's role may be made increasingly difficult unless guidelines with respect to confidentiality are clearly drawn.

#### Some Examples of Difficulty

The ACE Office of Research conducts surveys on the largest single sample of college freshmen in the country: Nearly 300,000 students participate annually in its Cooperative Institutional Research Program. For the most part, data is collected through survey questionnaires, although very occasionally--as in the current campus unrest study--personal interviews are conducted to permit more intensive exploration. Both research techniques involve the confidentiality issue, but because the survey method accounts for a much greater proportion of the total information collected, this paper will emphasize the steps taken to ensure confidentiality of the data derived from survey questionnaires. It should be borne in mind that analogous means are frequently used to maintain the confidentiality of interview data.

Occasionally, students who participate in the research program or professional organizations which have some interest in the educational enterprise volunteer commentary on the ACE Cooperative Institutional Research Program. Such comments, though they vary in appropriateness and perceptiveness, provide insights into what aspects of the confidentiality issue are important to different commentators. The following situations are fairly typical and should give the reader some feeling for the difficulties encountered at this level of research operations.

The first situation involved three students at a small technical college who requested that their completed questionnaires be returned. The three letters were highly similar, and one is reproduced below:

I am a freshman presently enrolled at (name of institution). On the day I enrolled, a sign guided me...to a large room in the Science building. Here we were presented with a very personal questionnaire, which we thought was mandatory because we had no choice but to take it and fill it out. We are all now realizing (sic) that the information given out is very personal and probes quite deeply into our personal lives. To be very blunt about it, the information requested is just none of your business, and furthermore, asking for our names, SS numbers, addresses, city, etc., makes one wonder just who will get hold of these surveys. In conclusion, I hereby DEMAND that you return my survey immediately to me personally at my home address as printed above. Next time, give students a choice; I'm sure you will avoid much trouble and misunderstanding.

Note that the student's major objections derived from his confusion over the "voluntariness" of participation, and his misunderstanding of the survey function, a misunderstanding which seems attributable to his not having been given adequate information at the time he took the survey. Since the students' letters were received before the questionnaires had been destroyed following data processing, the questionnaires were returned as requested. Two were unclaimed and were eventually returned by the post office to ACE. In addition, letters explaining more fully the purposes of the program were sent to each of the three students.

A second incident involved some students at a prestigious university who initiated a confrontation with college administrators on the issue of the freshman questionnaire survey. Their objections to it are reflected in the following handout which they circulated among the freshman class.

**YOU ARE FORCED TO TAKE THIS TEST  
MUST YOU TELL THE TRUTH?**

Why are you taking this test? Probably because it's required. Test-taking freaks can use it to express themselves, but what legitimate purpose can be served by forcing everyone to take the test?

If you resent the forced administration of this test, if you do not care to be arbitrarily defined and classified-- if you object for any reason to this test, consider some alternatives:

1. Do not answer any questions. Sign your name and leave the rest blank.
2. Answer the questions, but lie.
3. Read and think about the questions, but mark your answers according to some irrelevant criterion-- like the aesthetic charm of an ordered pattern of response marks or the mathematical probability that 20 percent will be correct if all "c's" are marked.
4. Join us in protest against next year's forced testing.

According to additional information provided by the university administrators, this small group effectively influenced a larger group to destroy all the completed questionnaires. Whether or not endorsement of the document destruction was obtained from all of the survey participants is not known. The arguments used by the radical minority were that the American Council on Education is a government agency or supported essentially by government funds, and that the survey was an evaluative instrument to be used for some malevolent, albeit undefined, purpose. Here again, it seems likely that procedures used in administering the questionnaire and the on-site explanations given to the respondent were inadequate; had they been better, the minority which instigated this situation might not have been motivated to do so.



In yet another instance, a student organization and a national legal enterprise group expressed concern over the possibility that university administrators would have access to questionnaire data in which individual respondents were identified and thus the survey permitted institutional invasion of the student's privacy. In consequence, both groups registered formal objections to the survey, although neither attempted to assess the likelihood of improper disclosure nor did they make any formal objection to the Office of Research's possession of the data. In particular, they objected to "certain questions...about illegal activity which could result in punitive action by the courts, governmental agencies, or respondents' administration..." The questions, in fact, referred to whether the respondent had ever participated in a demonstration, smoked, or drank alcoholic beverages. No respondent was asked to specify when, where, or under what circumstances he had done so.

Although we have little systematic data on changes in the nature of such objections over time, anecdotal information suggests that recently such objections have become more complex and more knowledgeable. The volume of correspondence has been small and is typified by the material provided. It covers the academic year 1968. These changes have been influenced not only by campus unrest, with its consequent confusion and mistrust, but also by students' increasing sophistication and their awareness of the issue of confidentiality.

In response to some of the situations encountered, the ACE Office of Research has taken several approaches to resolving these difficulties. First, certain administrative and procedural devices (described later) have been adopted. Second, efforts have been made to describe these devices to interested persons, including survey respondents. The form of the description

varies, depending on the objection and on the nature and detail of information required. Personal correspondence is convenient in view of the small number of individuals who write objections to the surveys. Detailed information, on stable attributes of the data system, are available in reports such as this one and in Bayer, et al., 1969. Other modes of communication are described in following sections of this paper.

#### ACE Policy and Procedures

A number of professional groups, as well as interested individuals, have recommended that ethical policies regarding the maintenance of data confidentiality be developed and stated explicitly. Such guidelines give to the interested participant or observer an unambiguous acknowledgement of the researcher's concern with safeguarding individual privacy. Moreover, the delineation of ethics serves as a useful reference system within which a policy may be implemented administratively. Insofar as such guidelines also include information about the function of the organization or the research function of the data, public misconceptions can be minimized.

#### Policy Statements and Advisory Committees

In view of these considerations, the American Council on Education has formally encouraged the members of its research staff to support, and to behave in accordance with, the code of ethics adopted by their respective professional organizations. The Council endorses adherence to the codes of ethics of, for example, the American Psychological Association (1967) and the National Education Association (1968), and the codes currently proposed by the American Sociological Association.

The relevance of current ethical codes to the confidentiality issue and to the educational researcher is exemplified by several provisions in the NEA Code (1968):

In fulfilling his obligation to the student, the educator:

Shall conduct professional business in such a way that he does not expose the student to unnecessary embarrassment or disparagement.

Shall not use professional relationships with students for private advantage.

Shall keep in confidence information that has been obtained in the course of professional service.

Shall permit no commercial exploitation of his professional position.

An explicit statement of policy relevant to administrative records and based on the codes of ethics was adopted by the American Council on Education in 1968. This policy was formally recommended for consideration to the colleges and universities which are ACE members and to other interested institutions. It provides a general rationale for developing further policy and discusses relevant aspects of informed consent, the fundamental principle of confidentiality, and the nature of student data which should not be recorded for administrative purposes. The recommendations can be summarized as follows:

- a. The organization should institute and firmly implement clear policies to protect the confidential contents of student records.
- b. When requests are made for information about the students' beliefs or behavior, and these requests seem contradictory to the fundamental principle of privacy of records, no response should be given other than affirmation of the principle, without consultation with an attorney.
- c. When there is any doubt about whether it is possible to safeguard confidentiality of a student's records, the respondent's

consent to its use should be formally sought and the data should not be used unless that consent is obtained.

- d. College and university policy should properly include consideration of the interests of research and scholarship to insure that freedom of inquiry for the scientific enterprise is not abridged.
- e. Colleges and universities should discontinue the maintenance of membership lists of student organizations, especially those involving political belief or action (American Council on Education, 1968).

These recommendations, and the ethical code on which they were based, were, in general, favorably received by academic administrators, and a New York Times editorial (July 25, 1967) acknowledged the usefulness of their substantive information. The recommendations overlap partly with a recent joint statement made by the American Association of University Professors, by the National Student Association, and other such organizations (AAUP Bulletin, Summer 1968).

To summarize, the American Council on Education assumes the responsibility for maintaining the confidentiality of all data obtained under its auspices, and this responsibility extends to records in which institutions are identifiable as well as to information about specific respondents. Data usage is strictly confined to statistical assessment in the context of research. The procedures that are currently being used preclude, or minimize, either accidental or deliberate use of the data for any function in which individuals or institutions must be identified. The nature of potential hazards is assayed in the following sections of this paper.

To help assure that these policies are implemented, research activities are monitored by the Council's Board of Directors, by the Office of Research Advisory Committee, and, in some instances, by special advisory committees appointed for specific projects. These committees, which meet periodically to assess research progress and data collection methods, emphasize appraisal of the scientific merit of research projects, the rights of the individuals who participate as subjects in these projects, and the relative benefits and risks to the subjects which may evolve from the conduct of the research project (Research Advisory Committee, 1969).

#### Administrative Policy and Procedures

Through an institutional representative, a college or university may voluntarily participate in the ACE Cooperative Institutional Research Program. At the request of the institutional representative, ACE provides a statement of policy and of procedures relevant to maintaining the confidentiality of data. This statement acknowledges ACE responsibility for safeguarding the records of both institutions and individuals within institutions and explains the administrative procedures necessary to implement the policy. The administrative and ethical basis for these procedures has been reviewed and approved by the Public Health Service as an ordinary part of Public Health Service grant review practices. Specific procedures conform to many (though not all) recommendations made by Sawyer and Schecter (1968) and others.

The regulations can be examined conveniently by using the flow chart given in Figure 1. The diagram outlines information acquisition and processing and indicates the physical environments, community of users, respondents, and interested researchers, and the forms which the data may take at the respective stages of processing.

At the institutional level, the respondent group comprises all individuals within the participating institution who provide information about themselves during the questionnaire survey. Freshmen at approximately 1200 colleges and universities constitute the major respondent population in ACE programs. The personnel at the institution are entirely responsible for administering and collecting questionnaires; the ACE Office of Research furnishes guidelines in order to expedite the process. Questionnaires are usually administered to a monitored group under stable conditions during the first two weeks of the academic year.

The questionnaire contains a statement addressed to the respondent that briefly describes its research function and tells why identifying information is necessary. The respondent is also encouraged to cooperate in the research, under the acknowledgement of ACE responsibility for maintaining the confidentiality of the data. The American Council on Education has no authority to demand that the student respond to the questionnaire, although the institutional authority may indicate that he should complete it. (The issue of the "voluntariness" is examined in more detail below).

Under the direction of the institutional representative, the questionnaires are packaged and forwarded to a commercial service bureau for processing. There they are maintained in locked files and destroyed when processing is completed. At the service bureau, marks on the questionnaires are optically scanned and recorded on magnetic tape. An ancillary benefit of machine processing is the reduction in the possibility that the data will be misused in that human handling of the documents is minimized. The product of the optical scanning operation is a statistical file which contains all responses submitted by persons within each institution and which uses arbitrary identification numbers to facilitate the

merging of data for followup studies and for accounting purposes. Other than this, the files identify neither the individual respondent nor the institution.

In a separate operation, identifying information is recorded on punched cards and then transferred to magnetic tape. This name-and-address file contains no questionnaire responses other than the identifying information. Both the raw statistical file and the name-and-address file are shipped separately to the ACE Office of Research for further coding and for data consolidation and analysis. If name-and-address files and statistical information were matched, the total file would comprise an "intelligence system," as described by Dunn (1968), for example, which identifies individuals as such. However, additional coding at ACE comprises the basis for a double linkage protection system which prevents such matching even by the Office of Research personnel.

The double linkage system is illustrated schematically in Figure 2. Each individual record in a given statistical data file is assigned a unique (arbitrary) accounting number. This series of numerals corresponds to Set 1 in the diagram. Each record in the corresponding name-and-address file is assigned another different accounting number (see Set 2). A code array (CA) of numbers, which match numbers in Set 1 to the corresponding one in Set 2 is created. The code linkage is maintained by a private organization under contract to (a) allow no direct access to the code system to anyone, including ACE staff, and (b) merge existing accounting numbers with new ones. ACE copies of code linkage are destroyed. In order to implement followup studies (Figure 3) more recent statistical data are assigned new accounting numbers (see Set 3). A new code linkage (CA') is then defined and translated by the service organization to the

original system. Merges of statistical data occur without the problems involved in handling statistical and name-and-address files jointly. Accidental or deliberate disclosure of previously collected individual records is impossible simply because the linkage code is not in ACE possession. Since the service organization is outside the United States, the codes which they contain are not subject to local or national regulations.

At the ACE level of processing, the name-and-address files are maintained at a commercial service organization under the series of administrative constraints given in the Department of Defense Industrial Security Manual (1966) for "CONFIDENTIAL CLASSIFICATION." That is, the magnetic tapes which contain identifying information are kept in locked storage, and their use is monitored by bonded guards in compliance with clearly specified security regulations. They are removed from storage only for those brief periods when envelopes for followup questionnaires are being addressed and only by written permission of the ACE Director of Research. All usage is systematically reported under the surveillance system. Accounting controls include receipt and dispatch records from each person handling these tapes, dates and time period of usage, and tape description. When they are being used, they are under surveillance to insure that they are neither copied nor misused. "Misuse" would include, for example, computer generated lists of names and addresses for commercial mailhouses. The statistical files are maintained by the ACE computer programming staff and are not subject to the same rigid controls prescribed for name-and-address files, the degree of control being largely a function of the form and substance of the particular statistical file.



The data are so extensive that, even if one had full access to the statistical files and documentation, it would be virtually impossible to match individuals and their responses. The same holds true for institutions. The statistical files and relevant documentation are monitored by the ACE professional staff to the extent that administrative and processing restrictions are necessary.

The statistical data are consolidated and then summarized in various printed forms for the community of users outside the ACE Office of Research. The form is determined by the particular user. Specifically, each institutional representative receives a statistical summary of responses to all questionnaires administered within his institution. This Institutional Report contains no information on individual respondents. To safeguard institutional privacy, the ACE refuses to send to an institution another institution's report, although it does advise those researchers and administrators who want to exchange or compare their institutional reports to contact each other directly. A second form of report, National Norms for Entering Freshmen (Creager, et al., 1968), is a statistical summary of all data for a particular year and is provided to each participating institution and made available to the general public. It identifies neither particular institutions nor individuals. The statistics it provides allow administrators and institutional researchers to compare their institution's attributes (as defined in the Institutional Reports) with those of a large well-specified sample of institutions.

Other analyses of the national data, in aggregate crosstabular form, are available to the community of users, including the participating institutions. Detailed regulations regarding access to data currently available

from the ACE Data Bank are provided in the User's Manual (Bayer, et al., 1969). Generally, individual researchers must make requests in accordance with specific procedures described in this manual. No individual identifying information, alone or in conjunction with records of responses, are in the domain of information available to the researcher under this data-accessing system; this information is entirely statistical in nature. Members of the Office of Research staff can develop special analysis for outside use from statistical files alone, thus eliminating accidental mishandling or misuse of the identifying information.

In previous years, a merged data file of individual responses, together with identification data within a particular institution, was created upon written request of the institutional representative, conditional upon written agreement by the institution's president to (a) maintain the confidentiality of the data and (b) use the data for research purposes only. For a brief period in 1968, this was altered: Institutions wishing to obtain individual statistical data for local research purposes did so, but identifying data were not provided. If the institution wished to merge ACE data with other individual data collected locally, the merging was done at cost by the ACE staff and the merged file returned without identifying data. The only condition under which ACE statistical and identifying data are provided to the institution is met when the questionnaire has been administered under circumstances in which the student has been clearly informed in advance that the data would be returned to his institution for use in local research projects. All institutions requesting tape copies of individual student data, with or without identifying information, must first provide ACE with specific written assurance that the confidentiality

of the data will be protected, that data will be used only for research purposes, and that no data will be entered into any of the official records or files of the institution.

#### Current Problems and Alternative Solutions

At each level of the information system outlined in Figure 1, there are potential difficulties in maintaining confidentiality of data. These problems usually present the researcher with some genuine opportunities for educating himself, and, perhaps more importantly, the respondent and other interested individuals. The solution of problems in this particular educational environment may be applicable to other larger systems of research.

#### Questionnaire Administration

The first level illustrated in Figure 1 represents the distribution, completion, and collection of questionnaires at the participating institution. Since identifying information appears on each questionnaire, this step represents a reduction in the ACE Office of Research staff's control of data confidentiality. That is, students or college personnel may have access to an individual record or a group of records. The members of the participating institution then become responsible for safeguarding the individual respondent's data, as they are in any situation where an institution requires students to provide information for institutional use. In cases where most questions are innocuous or useless for purposes other than research, the threat is lessened but not eliminated.

Like administrative records, questionnaire data may be used to persuade, influence, or intimidate students. To the extent that college personnel and students endorse the principle of confidentiality and behave accordingly, the threat is not crucial. Thus far, most institutions acknowledge responsibility to treat document administration and collection confidentially.

More formal provisions for controlling questionnaire administration are possible. The ACE Office of Research staff has considered a variety of alternative techniques. Physical security might be enhanced if respondents placed completed questionnaires in locked addressed boxes which would remain unopened until the data processing was initiated. Or the collection, packaging and mailing of completed documents might be done under the surveillance of local student, faculty, and administrative representatives, a procedure analogous to one proposed by Sawyer and Schechter (1968) for the National Data Bank System. More simply, the questionnaire could be constructed so that the identifying information is detachable from that portion of the document on which responses appear, and the identification section and completed questionnaires collected separately. Arbitrary identification numbers imprinted on both documents would permit later collation. The procedure, though not unwieldy, is expensive: The prices quoted by a major commercial optical scanning processing organization are approximately \$5000 to \$7000 higher than common processing costs.<sup>3</sup> The types of controls mentioned may generally be too expensive, complicated, or time-consuming to be appropriate in most situations. Perhaps more importantly, very elaborate regulations and procedures could provoke mistrust or suspicion that would interfere with the research or with the operations of the institution. That is, if one implies that suspicion is warranted, then feelings of suspicion may increase or persist unnecessarily. So far, informal surveillance by local administrative personnel seems to be suitable for the general case.

---

<sup>3</sup>Based on a sample of 300,000 and a 4-page document; identification consists of name and address.

The ACE policy has been to encourage and solicit cooperation by the respondent (i.e., the student). The participating institution usually uses the same approach, in effect, by administering the questionnaires. Information describing the purposes of the research and the nature of the research organization are given on the questionnaire and by the institutional representative to explain and encourage participation. The "voluntariness" of the situation is subject to modification by each college. Questionnaire completion may be designated as being highly desirable or as almost mandatory. There appears to be some justification for the college's requiring freshmen to complete the questionnaire, in that data is frequently collected in order to provide summary information that will aid in planning future admissions policies, revising curricula, etc. Longitudinal research on improving the educational process is important to the institution and, presumably, to the student. In addition, the Federal government and private funding agencies have given substantial support to such longitudinal research. Insofar as the student feels that he cannot conscientiously respond to questions relevant to social science or educational research, then conflict will arise, but may be minimized if the justification for and restrictions on the research function are made clear to the respondent. Such explanation, by providing the student with some understanding of the purpose of the research and the ways in which the data will be used, may help enlist his cooperation.

At the other extreme, the administrative control may be too lax and the degree of "voluntariness" too great. For instance, students may be advised to "complete the questionnaire and return it, if (they) feel like doing so." This situation occurs infrequently since ACE provides explicit

instructions for questionnaire administration (data from schools with too low a response rate is not included in the normative reports). Insofar as unstable situations undermine the reliability, completeness, and, therefore, the validity of the data, such an environment is undesirable. To the extent that the situation is made stable, but the voluntary aspect maintained, the difficulty is ameliorated.

#### Questionnaire Processing Services

At the second level of the information system, that of the optical scanning of questionnaires and the production of magnetic tape records (name-and-address files and statistical data files), data may be misused, inasmuch as completed questionnaires usually include respondent identification. Irregular data usage at this level could take several forms, conditional on the type of information solicited in the questionnaire and the environment under examination. The most likely is reproduction of tapes, including identification, for commercial exploitation (e.g., mailing lists).

If safeguarding magnetic tape record confidence is an important objective of the researcher, then endorsement of a relevant code of ethics by professionals in the computing disciplines is a reasonable expectation. Creation and endorsement of a code provides some clear basis for recognizing the existing hazards and examining strategies to avoid or minimize them. Although members of the Association for Computing Machinery have discussed guidelines for professional conduct in data processing--some of them relevant to the matter of confidentiality--actual results are disappointing. Although some members of the electronic data processing community recognize that an explicit code is desirable, other AAMC members appear to lack interest, and this indifference is one of the reasons that no code has been

adopted. Indirect pressure for code adoption on both commercial and professional organizations may be exerted by government agencies. For example, the Public Health Service (1968) requires that persons to whom grants are awarded for social science research acknowledge ethical policies and appropriate administrative procedures relevant to guarding against invasion of privacy. Insofar as researchers use computing facilities in which hazards are potential, ethical codes are desirable. When individual researchers utilize commercial computing facilities, the situation can be clarified somewhat if the service group endorses an appropriate policy. Requirements for safeguarding privacy of records can be included into contracts and so strengthen the efficacy of a desirable policy.

Physical security in the data-processing environments would involve chiefly some sort of automated protection for tape or disc files. However, computer manufacturers acknowledge that little effort has been made toward developing and selling hardware/software devices which have protection functions. There appear to be three major reasons for this lack of attention (Fanwick, 1967). First, competition among manufacturers is such that the development of such devices is not considered crucial unless there is a substantial demand for them. The demand is low, probably because of the social scientist's naivete regarding computing devices and the computer scientist's indifference to or ignorance of the problems of this user group. Difficulties of undermining current administrative procedures and mechanical devices (such as locked storage rooms, safes, and tape locks) are sufficient to impede or discourage most attempts to misuse the data. Moreover, the costs required in development of new hardware/software devices may not result in systems which provide much more protection than current

systems provide (Weismann, 1967). Third it can be argued that in the data-processing environment, records are not available to persons without special skills and that this population of persons competent enough to misuse the data purposely is too small to justify anxiety. But this argument is not particularly meaningful in that one single individual is capable of misusing hundreds of thousands of records.

The limited size and nature of the relevant community of potential violators is an important factor, however, since it means that adherence to existing, commonly used guidelines, notably the Department of Defense Industrial Security Manual (1966), can be monitored and controlled. Further, by including liability and negligence clauses into contracts with individuals or organizations, effective incentives for continued attention to the privacy issue can be provided.

Banshaf (1968) gives an expository account of the legal pitfalls, in a rather general context, relevant to computing facilities. While not discussing the confidentiality issue specifically, he does emphasize the difficulties of applying legal principles to a variety of problems in this technological environment. At the very least, his article strongly suggests the need for giving legal attention to the computer-related enterprises and for specifying requirements for maintenance of confidentiality in contracts with service groups.

#### Office of Research Operations

At the ACE level of the information system, statistical information is analyzed and results disseminated to the public. In addition, followup studies are conducted, which require the use of name-and-address files. ACE identification numbers in these files and in the existing statistical



data files are the basis for matching and merging data. Since potential difficulties arise with respect to access to the name-and-address files, more rigid or diverse controls of this access may be desirable, depending on the nature of the threat to confidentiality and on the source of objections to current operations. Various safeguards for confidentiality are considered here. The first depends largely on administrative regulation rather than on mechanical or automated procedures. An alternative device relates to computing and data processing methods. Yet another procedure involves capitalizing on the statistical nature of data analysis.

Consider, first, some of the problems that may be inherent in present administration procedures. For instance, it may be unwise to invest control in a single individual. His personal attributes (or eccentricities) become too important and his absence, regardless of his character, may cause unnecessary inconvenience in operating the system. Sawyer and Schechter (1968), Dunn (1968), and others have suggested devices for the National Data Bank System which would ameliorate problems in this context. A "neutral" organization including members of respondent groups and of interested professionals might function as a surveillance or key control unit in combination with the Director of Research. A second plausible alternative procedure is to extend direct responsibility to other professional staff members of the Office of Research.

The first possibility entails considerable effort, as well as the cooperation of persons outside the ACE organization and so it not possible at present, though its future implementation is being considered among other long-range Office of Research goals. Both alternatives have the disadvantage of being more bureaucratically complex and time-consuming than the current method.

The second device, which does not depend on in-house administrative regulations, might involve a computer hardware/software system which permits merges of data while completely denying any individual direct access to internal name-and-address files. Figure 3 contains a schematic diagram of such a system. The illustration shows a process in which more recently obtained identifying information is matched with existing name-and-address files and assigned accounting numbers used in the current system. The operation is conducted without permitting any person to handle directly existing name-and-address files. Matching is conducted independent of existing or newly obtained statistical files. A second match of current assigned accounting numbers and the arbitrary accounting system is used with the new data. The merge operation which combines new and existing statistical data is based on the accounting system associated with the existing name-and-address files.

If such a system indeed prevents access during operations, its importance cannot be underestimated. By making direct linkage of name-and-address information and statistical data impossible, no attempt (legal or otherwise) could possibly threaten the confidentiality of the records and thus the integrity of a single person would no longer be an issue. However, a hardware/software system of this type is not currently available, although some systems can be developed to meet requirements at least partially. Relative to current administrative and mechanical devices, systems which completely eliminate accessibility would be considerably more expensive.

Consider now the third alternative device, that which involves the form of the statistical data on which analyses are based. Typically, the researcher attempts to maintain an isomorphic relation between a person's responses on a questionnaire and records of these responses transformed to

magnetic tape or card form. But the costs of a perfect relation are prohibitive; data editing and cross-checking minimize deviations from the original responses. The nature and magnitude of error involved in this process have never been well documented. Suppose we assume that the accuracy of these records is fairly close to the accuracy required in business records; the records are reliable enough to be used meaningfully by the researcher.

Now, the possibility of data use or misuse is, of course, weakened when data are not reliable for any specific individual record. Frequently, the researcher can afford to undermine deliberately the integrity of a single record but preserve the integrity of the whole, at least with respect to statistical parameters. He does this by inoculating statistical data files with randomized error whose properties are known. A large body of literature deals with the problem of adjusting statistical estimates of population parameters, when the observations are subject to known measurement error. This procedure merely capitalizes on the statistical literature and on existing programs for generating (nearly) random numbers with specified parameters.

The "inoculation" accomplishes a number of important objectives. First, in the context of public interest in survey research, confusion between evaluative instruments, eavesdropping devices, administrative records, etc., may be minimized. The researcher can acknowledge the controlled unreliability of any individual record, a notion that is simple enough to communicate to the public. Second, the likelihood that records will be used in court litigation and in judicial or legislative inquiries is reduced substantially. Until jurimetrics (see Solomon, 1968)

becomes a solid basis for forming judgments about personal attributes or the behavior of a specific individual, this device should be an effective deterrent against legal use of individual survey research records. A distinct advantage is that neither the researcher nor the research community can obtain unambiguous information about specific persons, even if identification is, in fact, accomplished.

#### Observations on the Legal Environment

Conceivably, public or private investigatory agencies may have an interest in an individual's responses to an ACE Office of Research questionnaire. Threats to the maintenance of data confidentiality are possible regardless of the innocuousness of the responses, regardless of the degree of anonymity, and the threat increases if the survey assesses controversial beliefs or behavior. Because the ACE Office of Research has acknowledged responsibility for safeguarding respondent privacy, it is constantly examining the possibility of such inquiry. The following discussion is restricted to ways of reducing the risk to the researcher and to the survey respondent.

Consider some situations in which legal inquiry into survey results might be plausible. For instance, the investigatory agency may express interest in rather innocuous, "standard" information, such as the names and addresses of survey respondents within a specific institution. Frequently, this information is already public. That is, it can be obtained through published institutional membership lists, student telephone directories, etc., and the researcher in possession of identical information is not confronted with a problem; the investigatory agency can obtain the data more efficiently and easily from the public sources. Similarly, sex, age,

citizenship, state of origin, and other variables are occasionally public information. Moreover, direct information on specific individuals can be obtained more efficiently and probably more reliably through the investigatory agency's own facilities. The major difficulty, of course, occurs in those situations where responses may not be so innocuous. For instance, in our current research on campus unrest, we are attempting to examine variables antecedent to a student's opposition, activism, or indifference to protest activities. Changes in attitudes over time are exceedingly interesting, and are important if we are to judge the impact of campus unrest on the student and on the institution. In an atmosphere of disapproval toward unrest or even toward research, the acquisition of relevant data presents some problems. That is, public or private agencies may have an interest in using the data for judgments about specific individuals--an application which is not intended by the researcher.

When the solicited information is general rather than specific, the risk of possible damage to respondent and researcher is minimized but not eliminated. For instance, it is unlikely that a student who acknowledges that he participated in a protest but does not specify time or place will be subjected to punitive legal action. The standard regulations preventing disclosure of information would seem to be sufficient to discourage inquiry from private agencies. Moreover, the ACE Office of Research usually asks for rather general information, a strategy which not only protects against outside interference but also minimizes the intrusiveness of the questions.

In some instances, however, the researcher requires some specification of behavior. In more detailed interview surveys, for example, a respondent may provide the ACE Office of Research with detailed information, for research purposes only and under a promise of confidentiality. Public or private

investigation of an individual protocol may then be intrusive. Under extreme circumstances, the behavioral researcher may have to choose between violating his promise of confidentiality or being subjected to professional castigation or even legal punitive action. Two issues are relevant here: The likelihood of the situation's occurring and the protection afforded to respondent and researcher in the event it did occur. We can consider these issues as they apply to the response and to the circumstances in which specific information was solicited.

Although the possibility that survey data will be subpoenaed is a frequently mentioned bugaboo, the likelihood of this event's actually happening is rarely assessed. Behavioral researchers, research participants, and others who perceive such a threat usually do so on emotional grounds rather than through systematic examination of the particular survey circumstance. It should be pointed out that so far in no instance has a subpoena of behavioral research survey data been effected. This lack of legal precedent can be interpreted in several ways. First, individual records directly relevant to investigatory objectives can usually be obtained easily through other agencies. Thus, an investigatory group has no need to solicit information which is of dubious relevance to its interests and which involves direct interference in social science research. Furthermore, as was pointed out in the previous section, statistical reliability, or accuracy, of an individual record from a survey research information system must be considered if such records are to be introduced into formal litigation. Such survey records frequently do not conform to the accuracy of business records. The original survey questionnaires contain no signatures, and records of such documents are subject to well known psychometric

limitations (i.e., unreliability of responses, and inaccuracy of data processing and of information transmission).

In short, the survey research record is unlikely to have any value for use in litigation against a specific respondent. It is doubtful that the survey record conforms to the business exception to the hearsay rule and the best evidence rule. Banshaf (1968) describes these legal regulations in the context of magnetic tape and punched card reproduction of business documents. Regulations to which judicial agencies must conform are not consistently relevant to legislative inquiry (e.g., Senate subcommittee subpoena) or private investigation, however. The information protection system at the ACE Office of Research minimizes the possibility of improper disclosure to both public and private agencies, simply because crucial codes are not available to ACE personnel. Lacking this procedure, the proposed deliberate injection of statistical error into records would substantially reduce the likelihood of individual record usage for purposes other than research.

The sociolegal aspects of the confidentiality issue are frequently paradoxical. The following discussion gives examples of inconsistencies in the current situation. Historically, social scientists have had no general legal protection for information obtained under a promise of confidentiality. Indeed, only recently has the research participant's right to privacy of personality been acknowledged by judicial and legislative action (see Reubhausen and Brim, 1965). For the researcher, the so-called privileged communication laws for psychologist-client relations might appear to be relevant, but these regulations are statutory (extant in only 18 states) and have been applied in rather limited situations. Moreover, it is doubtful whether these laws can be applied to the questionnaire or interview survey in behavioral research (Reubhausen and Brim, 1965).

One rather interesting exception to the prevailing situation should be mentioned: Researchers at the U.S. Census Bureau receive constitutional protection for the kind of survey research which is often similar to the type of research considered in this paper. Census Bureau employees are legally bound to maintain confidentiality; punitive action may be taken against violators. The subpoena of records is blocked effectively by legislation, and the guarantee of protection from investigatory action based on individual records has been upheld by the courts. Unfortunately similar protection for other researchers is not likely to be instituted in the near future. This inconsistency can be considered discriminatory.

Another basic inconsistency occurs with respect to requirements for the acquisition of Federal grants in behavioral research. The U. S. Department of Health, Education and Welfare regulations (1969, p. 4) specify that potential risk to the respondent in survey research be considered. A similar provision is made in the regulations of the Presidential Office of Science and Technology (see Science, 1967), which emphasize possible disclosure of private information acquired by the researcher and possible violation of informal consent under the promise of confidentiality. The regulations are loosely defined but mandatory, and the grantee is required to define implementation policies. However, although the researcher must promise confidentiality, he is afforded no protection against a threat to his promise. If a public investigatory agency can make some attempt to force disclosure, and succeed, these prescriptions are gratuitous at best.

Even though legislative or judicial inquiry into individual records is unlikely and even though strategies are employed to minimize private or public interest in such inquiry, the need for a legal definition of rights and obligations remains. Ruebhausen and Brim, in a detailed



examination of these questions, have offered suggestions for their resolution: One is that privileged status be extended to information acquired by the social scientist, another, that civil or criminal remedies for breach of the right of privacy be provided.

Unfortunately, none of these suggestions are likely to receive immediate attention, evaluation, and action by the courts or legislative agencies. For the time being, heavy reliance must be placed on ethical codes, and on administrative procedures for their implementation within the particular survey condition. To these ends, the social scientist must devote serious effort to evaluating and implementing alternative strategies at each level of the information system.

#### Some Research Possibilities

In examining the confidentiality issues, and the alternative strategies for insuring individual privacy, there are some rather important inadequacies in our knowledge. We can, for example, consider the concepts of respondent anonymity and privacy to be determined by social factors. Research to establish relationships between these concepts and various reference groups--respondents, researchers, observers--may be very useful. Degrees and categorical variations of anonymity can be defined and evaluated with respect to these groups. Reubhausen and Brim, (1965) provide an example of the utility of this idea in a sociolegal context. Furthermore these variables can be systematically evaluated with respect to influence on response rate, and their links with socioeconomic attributes of respondents. Hartnett (1967) has completed a study which provides data on relationships between levels of anonymity and responses to various types of psychological test questions.

The intrusiveness of questions may be strongly related to the common psychological concept of "social desirability" of responses (Cronbach, 1960). In effect, the response is a function of its desirability relative to various social criteria. The interactions of these concepts when an individual takes the role of respondent, researcher, and observer could be interesting. It is likely that various methods of measuring the traits of privacy, anonymity, and intrusiveness are related; systematic assessment of the relations would be informative (see Campbell and Fiske, "Convergent and discriminant validation," Psychological Bulletin, 1959.)

Other variables which may influence response rate are feedback directed to the students on the survey and the type of college attended by the students. Survey researchers have only infrequently provided feedback to respondents based on statistical results. If results of studies were provided for participants perhaps response rates could be increased. Also, since the type of college--and whether it makes completion of questionnaires mandatory or voluntary-- appears to be connected with student objections to participation, a systematic study revealing the relationships between response rates under different conditions of "voluntariness" and the types of groups responding would be useful.

There are, of course, some important incentives for conducting such research. Surveys on relatively innocuous topics are commonplace. As surveys on more controversial topics expand, social questions implied by the concepts of voluntariness, intrusiveness, and anonymity must be answered, if only to maintain a basis for future research. A more efficient procedure for administration of questionnaires can be developed based on recognition that sampling requirements are a function of the response rates of

various groups and that these rates are affected by questionnaire attributes like those considered here. If productive, such research can probably be used to strengthen and clarify the rather recent growth of privacy as a legal and social prerogative of the individual. Such applications are not far removed from the use of statistical concepts in litigation as described by Solomon (1968). The ultimate incentive, of course, is the responsibility of the researcher to protect his subjects. The safeguards against intrusion of respondent privacy can be well defined only when the nature and extent of hazards to it are well specified.

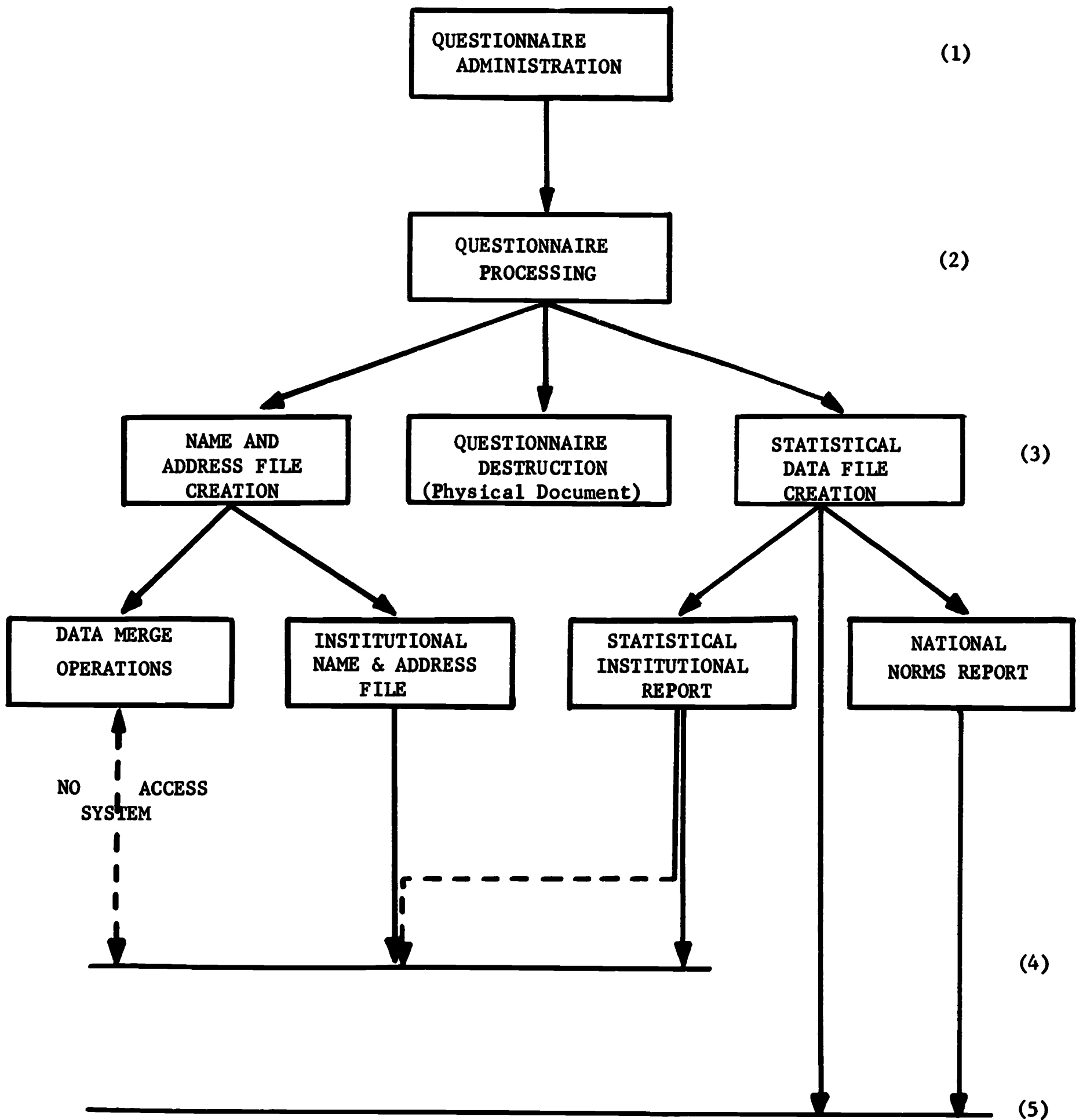

**Environments:**

- (1) PARTICIPATING INSTITUTION
- (2) ELECTRONIC DATA PROCESSING SERVICE ORGANIZATION
- (3) AMERICAN COUNCIL ON EDUCATION OPERATIONS
- (4) PARTICIPATING INSTITUTION RESEARCH
- (5) GENERAL COMMUNITY OF RESEARCHERS

Figure 1. Information Flow and Environments

RECODING

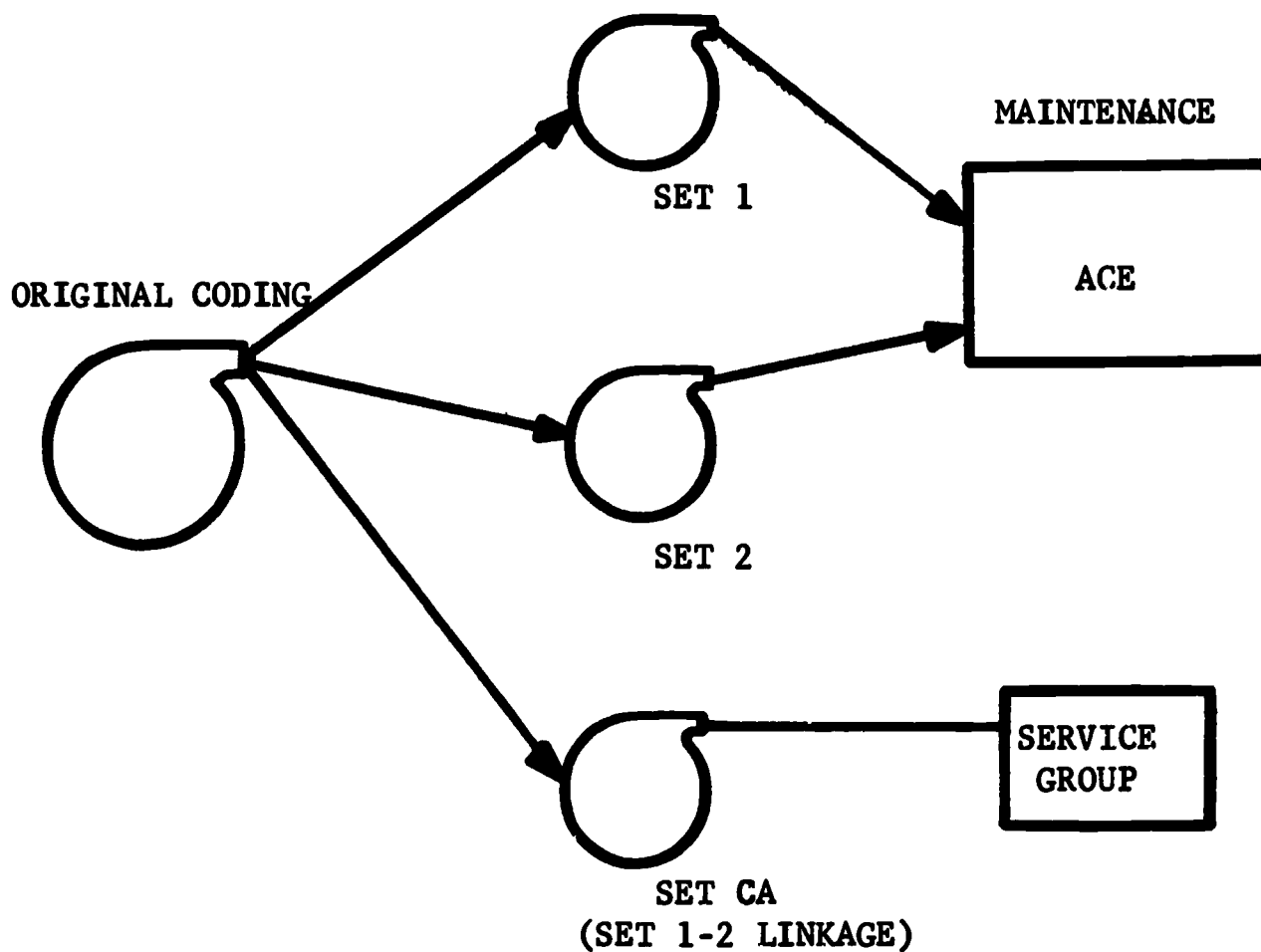

Figure 2. Link File Creation

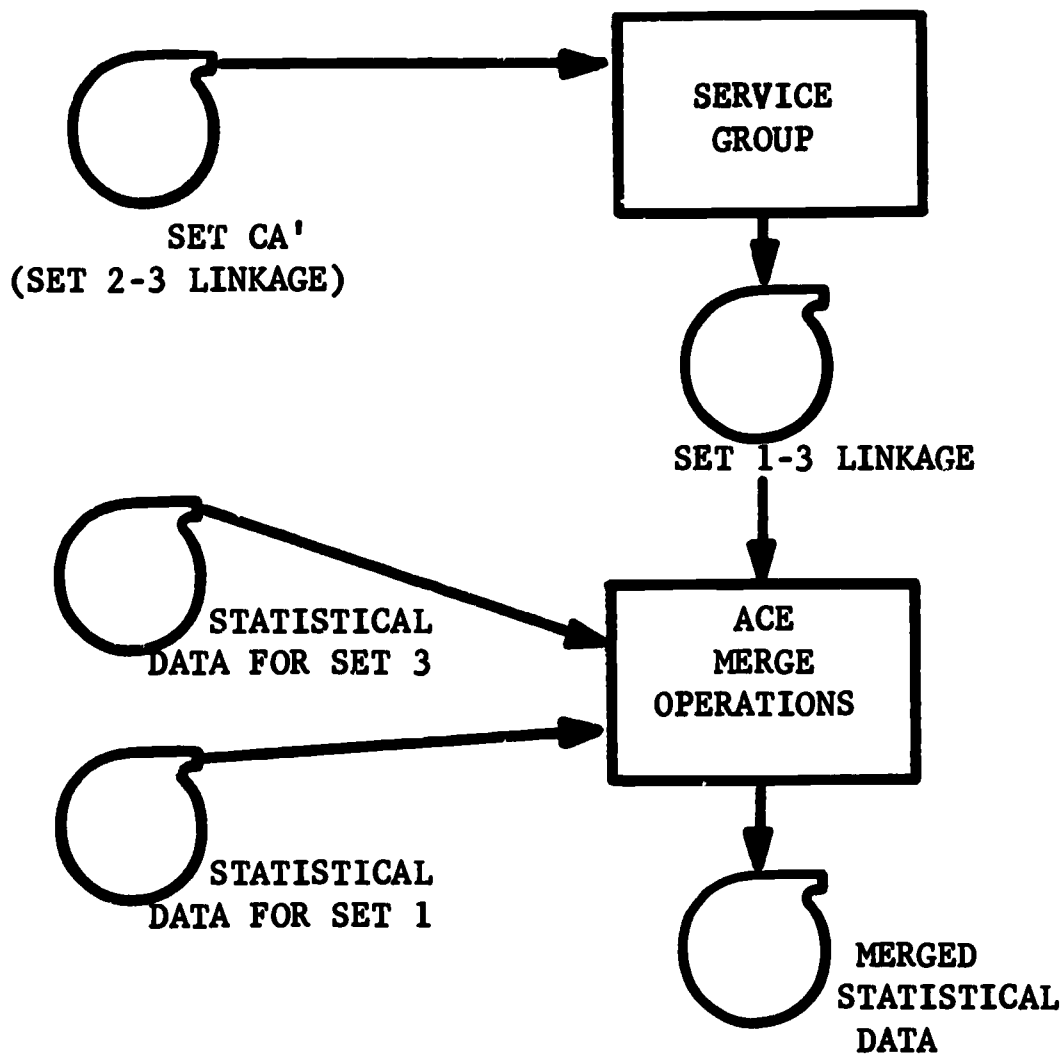

Figure 3. Merge Process

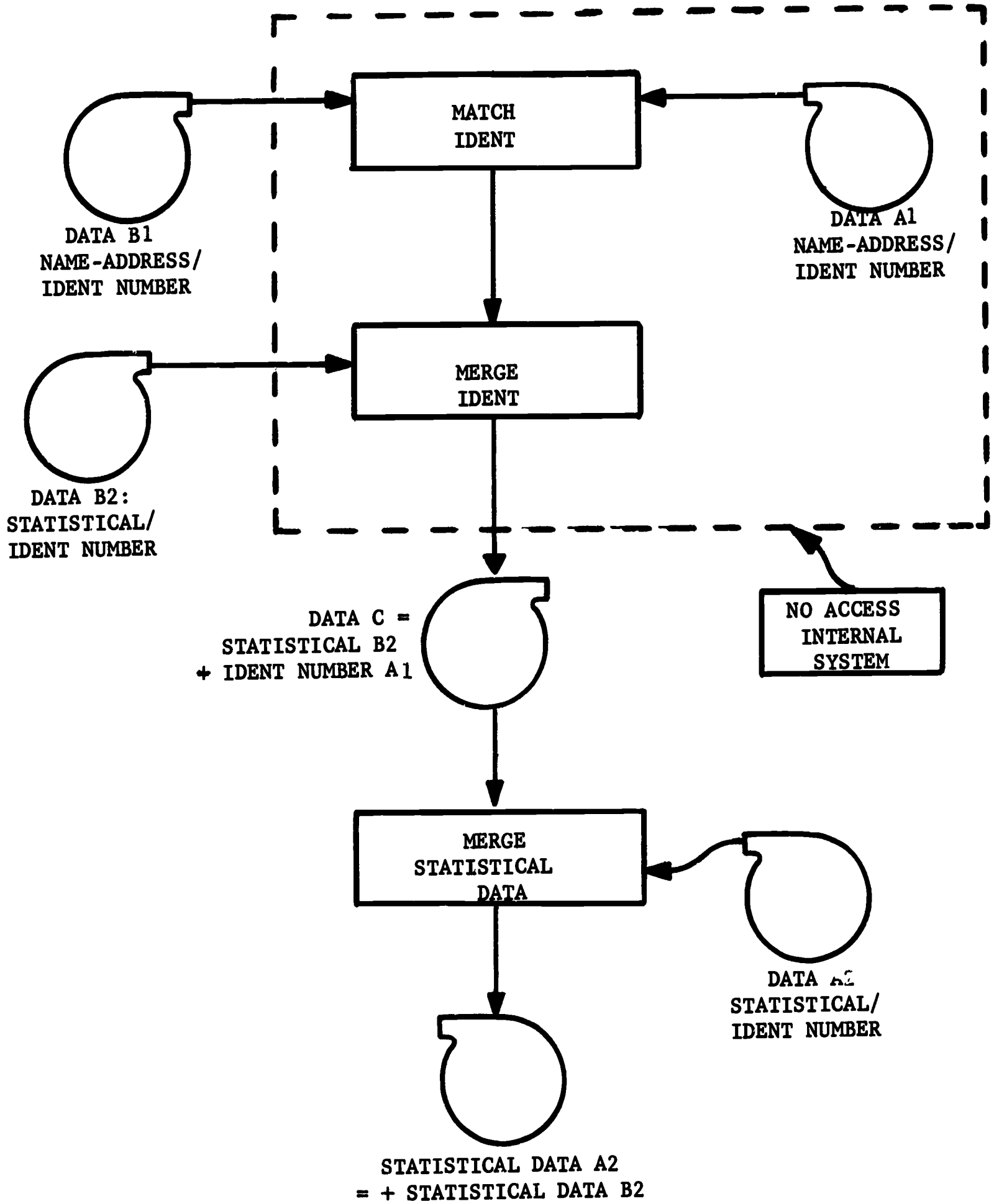

Figure 4. Schematic Chart: No Access Data Merge

# STUDENT INFORMATION FORM

818732

**YOUR NAME (please print)** \_\_\_\_\_  
First Middle or Maiden Last

**HOME STREET ADDRESS** \_\_\_\_\_

\_\_\_\_\_  
City State Zip Code (if known)

When were you born?  |  |

Month Day Year  
(01-12) (01-31)

Your Social Security Number (please copy carefully)  |  |

DO NOT MARK THIS GRID

0	0	0	0	0
1	1	1	1	1
2	2	2	2	2
3	3	3	3	3
4	4	4	4	4
5	5	5	5	5
6	6	6	6	6
7	7	7	7	7
8	8	8	8	8
9	9	9	9	9

**NOTE:**  
 The information in this report is being collected for the American Council on Education as part of a continuing study of higher education. Your cooperation in this research will contribute to an understanding of how students are affected by their college experiences. Identifying information has been requested by the Council in order to make subsequent mail follow-up studies possible. Your responses will be held in the strictest professional confidence, and will be used only in group summaries for research purposes.

0	0	0	0	0	0	0	0	0	0
1	1	1	1	1	1	1	1	1	1
2	2	2	2	2	2	2	2	2	2
3	3	3	3	3	3	3	3	3	3
4	4	4	4	4	4	4	4	4	4
5	5	5	5	5	5	5	5	5	5
6	6	6	6	6	6	6	6	6	6
7	7	7	7	7	7	7	7	7	7
8	8	8	8	8	8	8	8	8	8
9	9	9	9	9	9	9	9	9	9

**DIRECTIONS:** Your responses will be read by an optical mark reader. Your careful observance of these few simple rules will be most appreciated.

Use only black lead pencil (No. 2½ or softer). Make heavy black marks that fill the circle. Erase cleanly any answer you wish to change. Make no stray markings of any kind.

Example: Will marks made with ball pen or fountain pen be properly read?  Yes  No

1. Your Sex: Male  Female

2. How old will you be on December 31 of this year? (Mark one)

16 or younger <input type="radio"/>	20 <input type="radio"/>
17 <input type="radio"/>	21 <input type="radio"/>
18 <input type="radio"/>	Older than 21 <input type="radio"/>
19 <input type="radio"/>	

3. What was your average grade in secondary school? (Mark one)

A or A+ <input type="radio"/>	B- <input type="radio"/>
A- <input type="radio"/>	C+ <input type="radio"/>
B+ <input type="radio"/>	C <input type="radio"/>
B <input type="radio"/>	D <input type="radio"/>

4. To how many colleges other than this one did you actually apply for admission? From how many did you receive acceptances? (Mark one in each column)

	Applications	Acceptances
No other	<input type="radio"/>	<input type="radio"/>
One	<input type="radio"/>	<input type="radio"/>
Two	<input type="radio"/>	<input type="radio"/>
Three	<input type="radio"/>	<input type="radio"/>
Four	<input type="radio"/>	<input type="radio"/>
Five	<input type="radio"/>	<input type="radio"/>
Six or more	<input type="radio"/>	<input type="radio"/>

5. Mark one:

This is the first time I have enrolled in college as a freshman.

I came to this college from a junior college.

I came to this college from a four-year college or university.

6. The following questions deal with accomplishments that might possibly apply to your high school years. Do not be discouraged by this list; it covers many areas of interest and few students will be able to say "yes" to many items. (Mark all that apply)

Was elected president of one or more student organizations (recognized by the school)  **Yes**

Received a high rating (Good, Excellent) in a state or regional music contest.

Participated in a state or regional speech or debate contest

Had a major part in a play

Won a varsity letter (sports)

Won a prize or award in an art competition

Edited the school paper, yearbook, or literary magazine

Had poems, stories, essays, or articles published

Participated in a National Science Foundation summer program

Placed (first, second, or third) in a state or regional science contest

Was a member of a scholastic honor society

Won a Certificate of Merit or Letter of Commendation in the National Merit Program

7. What is the highest academic degree that you intend to obtain? (Mark one)

None

Associate (or equivalent)

Bachelor's degree (B.A., B.S., etc.)

Master's degree (M.A., M.S., etc.)

Ph.D. or Ed.D.

M.D., D.D.S., or D.V.M.

LL.B. or J.D.

B.D.

Other

8. Do you have any concern about your ability to finance your college education? (Mark one)

None (I am confident that I will have sufficient funds)

Some concern (but I will probably have enough funds)

Major concern (not sure I will be able to complete college)

9. Are you a twin? (Mark one)

No

Yes, identical

Yes, fraternal same sex

Yes, fraternal opposite sex

10. Through what source do you intend to finance the first year of your undergraduate education? (Mark one in each row)

Major Source  
Minor Source  
Not a Source

- Personal savings and or employment.
- Parental or other family aid .....
- Repayable loan .....
- Scholarship, grant, or other gift .....

11. What is the highest level of formal education obtained by your parents? (Mark one in each column)

- |                              | Father                | Mother                |
|------------------------------|-----------------------|-----------------------|
| Grammar school or less. .... | <input type="radio"/> | <input type="radio"/> |
| Some high school.....        | <input type="radio"/> | <input type="radio"/> |
| High school graduate.....    | <input type="radio"/> | <input type="radio"/> |
| Some college.....            | <input type="radio"/> | <input type="radio"/> |
| College degree.....          | <input type="radio"/> | <input type="radio"/> |
| Postgraduate degree.....     | <input type="radio"/> | <input type="radio"/> |

12. What is your best estimate of the total income last year of your parental family (not your own family if you are married)? Consider annual income from all sources before taxes. (Mark one)

- |  |   |
|--|---|
| Less than \$4,000 <input type="radio"/>  | \$15,000-\$19,999 <input type="radio"/> |
| \$4,000-\$5,999... <input type="radio"/> | \$20,000-\$24,999 <input type="radio"/> |
| \$6,000-\$7,999... <input type="radio"/> | \$25,000-\$29,999 <input type="radio"/> |
| \$8,000-\$9,999... <input type="radio"/> | \$30,000 or more <input type="radio"/>  |
| \$10,000-\$14,999 <input type="radio"/>  |   |

13. What is your racial background? (Mark one)

- Caucasian  Negro  American Indian   
Oriental  Other

14. Mark one in each column: Religion in Which You Were Reared Your Present Religious Preference

- |                     |                       |                       |
|---------------------|-----------------------|-----------------------|
| Protestant.....     | <input type="radio"/> | <input type="radio"/> |
| Roman Catholic..... | <input type="radio"/> | <input type="radio"/> |
| Jewish.....         | <input type="radio"/> | <input type="radio"/> |
| Other.....          | <input type="radio"/> | <input type="radio"/> |
| None.....           | <input type="radio"/> | <input type="radio"/> |

15. How would you rate the academic standards of your high school? (Mark one)

- Very high .....
- Fairly high.....
- About average.....
- Probably below average.....
- Definitely below average.....

16. Where did you rank academically in your high school graduating class? (Mark one)

- |                                   |                                   |                                   |
|-----------------------------------|-----------------------------------|-----------------------------------|
| Top 1%.... <input type="radio"/>  | Top 10%... <input type="radio"/>  | Top Quarter <input type="radio"/> |
| 2nd Quarter <input type="radio"/> | 3rd Quarter <input type="radio"/> | 4th Quarter <input type="radio"/> |

17. Where did you live for most of the time while you were growing up?

- On a farm.....
- in a small town.....
- In a moderate size town or city.....
- In a suburb of a large city.....
- in a large city.....

18. During the past year in school, how often did the following statements apply to you? (Mark one in each row)

- |  | Always                | Usually               | Sometimes             | Rarely or Never       |
|--|-----------------------|-----------------------|-----------------------|-----------------------|
| Turned in assigned work on time.....                             | <input type="radio"/> | <input type="radio"/> | <input type="radio"/> | <input type="radio"/> |
| Had trouble concentrating on assignments.....                    | <input type="radio"/> | <input type="radio"/> | <input type="radio"/> | <input type="radio"/> |
| Kept my desk or study place neat.....                            | <input type="radio"/> | <input type="radio"/> | <input type="radio"/> | <input type="radio"/> |
| Was too bored to study.....                                      | <input type="radio"/> | <input type="radio"/> | <input type="radio"/> | <input type="radio"/> |
| Outlined the main points of a reading assignment.....            | <input type="radio"/> | <input type="radio"/> | <input type="radio"/> | <input type="radio"/> |
| Made careless mistakes on a test.....                            | <input type="radio"/> | <input type="radio"/> | <input type="radio"/> | <input type="radio"/> |
| Did my homework at the same time every day.....                  | <input type="radio"/> | <input type="radio"/> | <input type="radio"/> | <input type="radio"/> |
| Studied alone.....   | <input type="radio"/> | <input type="radio"/> | <input type="radio"/> | <input type="radio"/> |
| Put off starting my homework.....                                | <input type="radio"/> | <input type="radio"/> | <input type="radio"/> | <input type="radio"/> |
| Got "exam jitters".....  | <input type="radio"/> | <input type="radio"/> | <input type="radio"/> | <input type="radio"/> |
| Fell asleep while studying.....                                  | <input type="radio"/> | <input type="radio"/> | <input type="radio"/> | <input type="radio"/> |
| Memorized facts or formulas without understanding them.....      | <input type="radio"/> | <input type="radio"/> | <input type="radio"/> | <input type="radio"/> |
| Quit before completing a difficult assignment.....               | <input type="radio"/> | <input type="radio"/> | <input type="radio"/> | <input type="radio"/> |
| Shared or reviewed notes with other students.....                | <input type="radio"/> | <input type="radio"/> | <input type="radio"/> | <input type="radio"/> |
| Checked my work before turning in a paper or test.....           | <input type="radio"/> | <input type="radio"/> | <input type="radio"/> | <input type="radio"/> |
| Did unrequired work for extra credit.....                        | <input type="radio"/> | <input type="radio"/> | <input type="radio"/> | <input type="radio"/> |
| Made-up and took my own test for practice.....                   | <input type="radio"/> | <input type="radio"/> | <input type="radio"/> | <input type="radio"/> |
| Daydreamed while studying.....                                   | <input type="radio"/> | <input type="radio"/> | <input type="radio"/> | <input type="radio"/> |
| Got a lower grade than I deserved in a test or assignment.....   | <input type="radio"/> | <input type="radio"/> | <input type="radio"/> | <input type="radio"/> |
| Included minor details when taking notes.....                    | <input type="radio"/> | <input type="radio"/> | <input type="radio"/> | <input type="radio"/> |
| Wasted too much time on bull sessions.....                       | <input type="radio"/> | <input type="radio"/> | <input type="radio"/> | <input type="radio"/> |
| Analyzed my mistakes to be sure I understood what was wrong..... | <input type="radio"/> | <input type="radio"/> | <input type="radio"/> | <input type="radio"/> |
| Carefully went over diagrams or tables in the textbook.....      | <input type="radio"/> | <input type="radio"/> | <input type="radio"/> | <input type="radio"/> |
| Studied with the radio or record player on.....                  | <input type="radio"/> | <input type="radio"/> | <input type="radio"/> | <input type="radio"/> |
| Studied with the TV on.....                                      | <input type="radio"/> | <input type="radio"/> | <input type="radio"/> | <input type="radio"/> |
| Clarified assignments with an instructor.....                    | <input type="radio"/> | <input type="radio"/> | <input type="radio"/> | <input type="radio"/> |

19. What is your best guess as to the chances that you will: (Mark one in each row)

- |   | Very Good Chance      | Some Chance           | Very Little Chance    | No Chance             |
|---|-----------------------|-----------------------|-----------------------|-----------------------|
| Get married while in college?.....                                | <input type="radio"/> | <input type="radio"/> | <input type="radio"/> | <input type="radio"/> |
| Get married within a year after college?.....                     | <input type="radio"/> | <input type="radio"/> | <input type="radio"/> | <input type="radio"/> |
| Obtain an A- or better over-all grade point average?.....         | <input type="radio"/> | <input type="radio"/> | <input type="radio"/> | <input type="radio"/> |
| Change major field?.....  | <input type="radio"/> | <input type="radio"/> | <input type="radio"/> | <input type="radio"/> |
| Change career choice?.....  | <input type="radio"/> | <input type="radio"/> | <input type="radio"/> | <input type="radio"/> |
| Fail one or more courses?.....                                    | <input type="radio"/> | <input type="radio"/> | <input type="radio"/> | <input type="radio"/> |
| Graduate with honors?.....  | <input type="radio"/> | <input type="radio"/> | <input type="radio"/> | <input type="radio"/> |
| Be elected to a student office?.....                              | <input type="radio"/> | <input type="radio"/> | <input type="radio"/> | <input type="radio"/> |
| Join a social fraternity, sorority, or club?.....                 | <input type="radio"/> | <input type="radio"/> | <input type="radio"/> | <input type="radio"/> |
| Author or co-author a published article?.....                     | <input type="radio"/> | <input type="radio"/> | <input type="radio"/> | <input type="radio"/> |
| Be elected to an academic honor society?.....                     | <input type="radio"/> | <input type="radio"/> | <input type="radio"/> | <input type="radio"/> |
| Participate in student protests or demonstrations?.....           | <input type="radio"/> | <input type="radio"/> | <input type="radio"/> | <input type="radio"/> |
| Drop out of this college temporarily (exclude transferring)?..... | <input type="radio"/> | <input type="radio"/> | <input type="radio"/> | <input type="radio"/> |
| Drop out permanently (exclude transferring)?.....                 | <input type="radio"/> | <input type="radio"/> | <input type="radio"/> | <input type="radio"/> |
| Transfer to another college before graduating?.....               | <input type="radio"/> | <input type="radio"/> | <input type="radio"/> | <input type="radio"/> |



20. Mark one in each column:

	Your current home state	Your birthplace	Your father's birthplace	Your mother's birthplace
Alabama	<input type="radio"/>	<input type="radio"/>	<input type="radio"/>	<input type="radio"/>
Alaska	<input type="radio"/>	<input type="radio"/>	<input type="radio"/>	<input type="radio"/>
Arizona	<input type="radio"/>	<input type="radio"/>	<input type="radio"/>	<input type="radio"/>
Arkansas	<input type="radio"/>	<input type="radio"/>	<input type="radio"/>	<input type="radio"/>
California	<input type="radio"/>	<input type="radio"/>	<input type="radio"/>	<input type="radio"/>
Colorado	<input type="radio"/>	<input type="radio"/>	<input type="radio"/>	<input type="radio"/>
Connecticut	<input type="radio"/>	<input type="radio"/>	<input type="radio"/>	<input type="radio"/>
Delaware	<input type="radio"/>	<input type="radio"/>	<input type="radio"/>	<input type="radio"/>
D.C.	<input type="radio"/>	<input type="radio"/>	<input type="radio"/>	<input type="radio"/>
Florida	<input type="radio"/>	<input type="radio"/>	<input type="radio"/>	<input type="radio"/>
Georgia	<input type="radio"/>	<input type="radio"/>	<input type="radio"/>	<input type="radio"/>
Hawaii	<input type="radio"/>	<input type="radio"/>	<input type="radio"/>	<input type="radio"/>
Idaho	<input type="radio"/>	<input type="radio"/>	<input type="radio"/>	<input type="radio"/>
Illinois	<input type="radio"/>	<input type="radio"/>	<input type="radio"/>	<input type="radio"/>
Indiana	<input type="radio"/>	<input type="radio"/>	<input type="radio"/>	<input type="radio"/>
Iowa	<input type="radio"/>	<input type="radio"/>	<input type="radio"/>	<input type="radio"/>
Kansas	<input type="radio"/>	<input type="radio"/>	<input type="radio"/>	<input type="radio"/>
Kentucky	<input type="radio"/>	<input type="radio"/>	<input type="radio"/>	<input type="radio"/>
Louisiana	<input type="radio"/>	<input type="radio"/>	<input type="radio"/>	<input type="radio"/>
Maine	<input type="radio"/>	<input type="radio"/>	<input type="radio"/>	<input type="radio"/>
Maryland	<input type="radio"/>	<input type="radio"/>	<input type="radio"/>	<input type="radio"/>
Massachusetts	<input type="radio"/>	<input type="radio"/>	<input type="radio"/>	<input type="radio"/>
Michigan	<input type="radio"/>	<input type="radio"/>	<input type="radio"/>	<input type="radio"/>
Minnesota	<input type="radio"/>	<input type="radio"/>	<input type="radio"/>	<input type="radio"/>
Mississippi	<input type="radio"/>	<input type="radio"/>	<input type="radio"/>	<input type="radio"/>
Missouri	<input type="radio"/>	<input type="radio"/>	<input type="radio"/>	<input type="radio"/>
Montana	<input type="radio"/>	<input type="radio"/>	<input type="radio"/>	<input type="radio"/>
Nebraska	<input type="radio"/>	<input type="radio"/>	<input type="radio"/>	<input type="radio"/>
Nevada	<input type="radio"/>	<input type="radio"/>	<input type="radio"/>	<input type="radio"/>
New Hampshire	<input type="radio"/>	<input type="radio"/>	<input type="radio"/>	<input type="radio"/>
New Jersey	<input type="radio"/>	<input type="radio"/>	<input type="radio"/>	<input type="radio"/>
New Mexico	<input type="radio"/>	<input type="radio"/>	<input type="radio"/>	<input type="radio"/>
New York	<input type="radio"/>	<input type="radio"/>	<input type="radio"/>	<input type="radio"/>
North Carolina	<input type="radio"/>	<input type="radio"/>	<input type="radio"/>	<input type="radio"/>
North Dakota	<input type="radio"/>	<input type="radio"/>	<input type="radio"/>	<input type="radio"/>
Ohio	<input type="radio"/>	<input type="radio"/>	<input type="radio"/>	<input type="radio"/>
Oklahoma	<input type="radio"/>	<input type="radio"/>	<input type="radio"/>	<input type="radio"/>
Oregon	<input type="radio"/>	<input type="radio"/>	<input type="radio"/>	<input type="radio"/>
Pennsylvania	<input type="radio"/>	<input type="radio"/>	<input type="radio"/>	<input type="radio"/>
Rhode Island	<input type="radio"/>	<input type="radio"/>	<input type="radio"/>	<input type="radio"/>
South Carolina	<input type="radio"/>	<input type="radio"/>	<input type="radio"/>	<input type="radio"/>
South Dakota	<input type="radio"/>	<input type="radio"/>	<input type="radio"/>	<input type="radio"/>
Tennessee	<input type="radio"/>	<input type="radio"/>	<input type="radio"/>	<input type="radio"/>
Texas	<input type="radio"/>	<input type="radio"/>	<input type="radio"/>	<input type="radio"/>
Utah	<input type="radio"/>	<input type="radio"/>	<input type="radio"/>	<input type="radio"/>
Vermont	<input type="radio"/>	<input type="radio"/>	<input type="radio"/>	<input type="radio"/>
Virginia	<input type="radio"/>	<input type="radio"/>	<input type="radio"/>	<input type="radio"/>
Washington	<input type="radio"/>	<input type="radio"/>	<input type="radio"/>	<input type="radio"/>
West Virginia	<input type="radio"/>	<input type="radio"/>	<input type="radio"/>	<input type="radio"/>
Wisconsin	<input type="radio"/>	<input type="radio"/>	<input type="radio"/>	<input type="radio"/>
Wyoming	<input type="radio"/>	<input type="radio"/>	<input type="radio"/>	<input type="radio"/>
Canada	<input type="radio"/>	<input type="radio"/>	<input type="radio"/>	<input type="radio"/>
Latin America	<input type="radio"/>	<input type="radio"/>	<input type="radio"/>	<input type="radio"/>
Europe	<input type="radio"/>	<input type="radio"/>	<input type="radio"/>	<input type="radio"/>
Asia	<input type="radio"/>	<input type="radio"/>	<input type="radio"/>	<input type="radio"/>

21. Mark only three responses, one in each column.

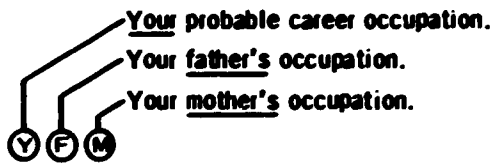

NOTE: If your father (or mother) is deceased, please indicate his (her) last occupation.

Accountant or actuary	<input type="radio"/>	<input type="radio"/>	<input type="radio"/>
Actor or entertainer	<input type="radio"/>	<input type="radio"/>	<input type="radio"/>
Architect	<input type="radio"/>	<input type="radio"/>	<input type="radio"/>
Artist	<input type="radio"/>	<input type="radio"/>	<input type="radio"/>
Business (clerical)	<input type="radio"/>	<input type="radio"/>	<input type="radio"/>
Business executive (management, administrator)	<input type="radio"/>	<input type="radio"/>	<input type="radio"/>
Business owner or proprietor	<input type="radio"/>	<input type="radio"/>	<input type="radio"/>
Business salesman or buyer	<input type="radio"/>	<input type="radio"/>	<input type="radio"/>
Clergyman (minister, priest)	<input type="radio"/>	<input type="radio"/>	<input type="radio"/>
Clergy (other religious)	<input type="radio"/>	<input type="radio"/>	<input type="radio"/>
Clinical psychologist	<input type="radio"/>	<input type="radio"/>	<input type="radio"/>
College teacher	<input type="radio"/>	<input type="radio"/>	<input type="radio"/>
Computer programmer	<input type="radio"/>	<input type="radio"/>	<input type="radio"/>
Conservationist or forester	<input type="radio"/>	<input type="radio"/>	<input type="radio"/>
Dentist (including orthodontist)	<input type="radio"/>	<input type="radio"/>	<input type="radio"/>
Dietitian or home economist	<input type="radio"/>	<input type="radio"/>	<input type="radio"/>
Engineer	<input type="radio"/>	<input type="radio"/>	<input type="radio"/>
Farmer or rancher	<input type="radio"/>	<input type="radio"/>	<input type="radio"/>
Foreign service worker (including diplomat)	<input type="radio"/>	<input type="radio"/>	<input type="radio"/>
Housewife	<input type="radio"/>	<input type="radio"/>	<input type="radio"/>
Interior decorator (including designer)	<input type="radio"/>	<input type="radio"/>	<input type="radio"/>
Interpreter (translator)	<input type="radio"/>	<input type="radio"/>	<input type="radio"/>
Lab technician or hygienist	<input type="radio"/>	<input type="radio"/>	<input type="radio"/>
Law enforcement officer	<input type="radio"/>	<input type="radio"/>	<input type="radio"/>
Lawyer (attorney)	<input type="radio"/>	<input type="radio"/>	<input type="radio"/>
Military service (career)	<input type="radio"/>	<input type="radio"/>	<input type="radio"/>
Musician (performer, composer)	<input type="radio"/>	<input type="radio"/>	<input type="radio"/>
Nurse	<input type="radio"/>	<input type="radio"/>	<input type="radio"/>
Optometrist	<input type="radio"/>	<input type="radio"/>	<input type="radio"/>
Pharmacist	<input type="radio"/>	<input type="radio"/>	<input type="radio"/>
Physician	<input type="radio"/>	<input type="radio"/>	<input type="radio"/>
School counselor	<input type="radio"/>	<input type="radio"/>	<input type="radio"/>
School principal or superintendent	<input type="radio"/>	<input type="radio"/>	<input type="radio"/>
Scientific researcher	<input type="radio"/>	<input type="radio"/>	<input type="radio"/>
Social worker	<input type="radio"/>	<input type="radio"/>	<input type="radio"/>
Statistician	<input type="radio"/>	<input type="radio"/>	<input type="radio"/>
Therapist (physical, occupational, speech)	<input type="radio"/>	<input type="radio"/>	<input type="radio"/>
Teacher (elementary)	<input type="radio"/>	<input type="radio"/>	<input type="radio"/>
Teacher (secondary)	<input type="radio"/>	<input type="radio"/>	<input type="radio"/>
Veterinarian	<input type="radio"/>	<input type="radio"/>	<input type="radio"/>
Writer or journalist	<input type="radio"/>	<input type="radio"/>	<input type="radio"/>
Skilled trades	<input type="radio"/>	<input type="radio"/>	<input type="radio"/>
Other	<input type="radio"/>		
Undecided	<input type="radio"/>		
Laborer (unskilled)		<input type="radio"/>	<input type="radio"/>
Semi-skilled worker		<input type="radio"/>	<input type="radio"/>
Other occupation		<input type="radio"/>	<input type="radio"/>
Unemployed		<input type="radio"/>	

22. Below is a list of 66 different undergraduate major fields grouped into general categories. Mark only three of the 66 fields as follows:

- ① First choice (your probable major field of study).
- ② Second choice.
- ③ The field of study which is least appealing to you.

**ARTS AND HUMANITIES**

Architecture	<input type="radio"/>	<input type="radio"/>	<input type="radio"/>
English (literature)	<input type="radio"/>	<input type="radio"/>	<input type="radio"/>
Fine arts	<input type="radio"/>	<input type="radio"/>	<input type="radio"/>
History	<input type="radio"/>	<input type="radio"/>	<input type="radio"/>
Journalism (writing)	<input type="radio"/>	<input type="radio"/>	<input type="radio"/>
Language (modern)	<input type="radio"/>	<input type="radio"/>	<input type="radio"/>
Language (other)	<input type="radio"/>	<input type="radio"/>	<input type="radio"/>
Music	<input type="radio"/>	<input type="radio"/>	<input type="radio"/>
Philosophy	<input type="radio"/>	<input type="radio"/>	<input type="radio"/>
Speech and drama	<input type="radio"/>	<input type="radio"/>	<input type="radio"/>
Theology	<input type="radio"/>	<input type="radio"/>	<input type="radio"/>
Other	<input type="radio"/>	<input type="radio"/>	<input type="radio"/>

**BIOLOGICAL SCIENCE**

Biology (general)	<input type="radio"/>	<input type="radio"/>	<input type="radio"/>
Biochemistry	<input type="radio"/>	<input type="radio"/>	<input type="radio"/>
Biophysics	<input type="radio"/>	<input type="radio"/>	<input type="radio"/>
Botany	<input type="radio"/>	<input type="radio"/>	<input type="radio"/>
Zoology	<input type="radio"/>	<input type="radio"/>	<input type="radio"/>
Other	<input type="radio"/>	<input type="radio"/>	<input type="radio"/>

**BUSINESS**

Accounting	<input type="radio"/>	<input type="radio"/>	<input type="radio"/>
Business admin	<input type="radio"/>	<input type="radio"/>	<input type="radio"/>
Electronic data processing	<input type="radio"/>	<input type="radio"/>	<input type="radio"/>
Secretarial studies	<input type="radio"/>	<input type="radio"/>	<input type="radio"/>
Other	<input type="radio"/>	<input type="radio"/>	<input type="radio"/>

**ENGINEERING**

Aeronautical	<input type="radio"/>	<input type="radio"/>	<input type="radio"/>
Civil	<input type="radio"/>	<input type="radio"/>	<input type="radio"/>
Chemical	<input type="radio"/>	<input type="radio"/>	<input type="radio"/>
Electrical	<input type="radio"/>	<input type="radio"/>	<input type="radio"/>
Industrial	<input type="radio"/>	<input type="radio"/>	<input type="radio"/>
Mechanical	<input type="radio"/>	<input type="radio"/>	<input type="radio"/>
Other	<input type="radio"/>	<input type="radio"/>	<input type="radio"/>

**PHYSICAL SCIENCE**

Chemistry	<input type="radio"/>	<input type="radio"/>	<input type="radio"/>
Earth science	<input type="radio"/>	<input type="radio"/>	<input type="radio"/>
Mathematics	<input type="radio"/>	<input type="radio"/>	<input type="radio"/>
Physics	<input type="radio"/>	<input type="radio"/>	<input type="radio"/>
Statistics	<input type="radio"/>	<input type="radio"/>	<input type="radio"/>
Other	<input type="radio"/>	<input type="radio"/>	<input type="radio"/>

**PROFESSIONAL**

Health Technology (medical, dental, laboratory)	<input type="radio"/>	<input type="radio"/>	<input type="radio"/>
Nursing	<input type="radio"/>	<input type="radio"/>	<input type="radio"/>
Pharmacy	<input type="radio"/>	<input type="radio"/>	<input type="radio"/>
Podiatry	<input type="radio"/>	<input type="radio"/>	<input type="radio"/>
Prelaw	<input type="radio"/>	<input type="radio"/>	<input type="radio"/>
Premedical	<input type="radio"/>	<input type="radio"/>	<input type="radio"/>
Preveterinary	<input type="radio"/>	<input type="radio"/>	<input type="radio"/>
Therapy (occupat., physical, speech)	<input type="radio"/>	<input type="radio"/>	<input type="radio"/>
Other	<input type="radio"/>	<input type="radio"/>	<input type="radio"/>

**SOCIAL SCIENCE**

Anthropology	<input type="radio"/>	<input type="radio"/>	<input type="radio"/>
Economics	<input type="radio"/>	<input type="radio"/>	<input type="radio"/>
Education	<input type="radio"/>	<input type="radio"/>	<input type="radio"/>
History	<input type="radio"/>	<input type="radio"/>	<input type="radio"/>
Political science (government, int. relations)	<input type="radio"/>	<input type="radio"/>	<input type="radio"/>
Psychology	<input type="radio"/>	<input type="radio"/>	<input type="radio"/>
Social work	<input type="radio"/>	<input type="radio"/>	<input type="radio"/>
Sociology	<input type="radio"/>	<input type="radio"/>	<input type="radio"/>
Other	<input type="radio"/>	<input type="radio"/>	<input type="radio"/>

**OTHER FIELDS**

Agriculture	<input type="radio"/>	<input type="radio"/>	<input type="radio"/>
Communications (radio, T.V., etc.)	<input type="radio"/>	<input type="radio"/>	<input type="radio"/>
Electronics (technology)	<input type="radio"/>	<input type="radio"/>	<input type="radio"/>
Forestry	<input type="radio"/>	<input type="radio"/>	<input type="radio"/>
Home economics	<input type="radio"/>	<input type="radio"/>	<input type="radio"/>
Industrial arts	<input type="radio"/>	<input type="radio"/>	<input type="radio"/>
Library science	<input type="radio"/>	<input type="radio"/>	<input type="radio"/>
Military science	<input type="radio"/>	<input type="radio"/>	<input type="radio"/>
Physical education and recreation	<input type="radio"/>	<input type="radio"/>	<input type="radio"/>
Other (technical)	<input type="radio"/>	<input type="radio"/>	<input type="radio"/>
Other (nontechnical)	<input type="radio"/>	<input type="radio"/>	<input type="radio"/>
Undecided	<input type="radio"/>	<input type="radio"/>	<input type="radio"/>

Please be sure that only three circles have been marked in the above list.

23. Below is a general list of things that students sometimes do. Indicate which of these things you did during the past year in school. If you engaged in an activity frequently, mark "F." If you engaged in an activity one or more times, but not frequently, mark "O" (occasionally). Mark "N" (not at all) if you have not performed the activity during the past year. (Mark one for each item)

	Frequently	Occasionally	Not at all
Voted in a student election.....	F	O	N
Came late to class.....	F	O	N
Played a musical instrument.....	F	O	N
Studied in the library.....	F	O	N
Checked out a book or journal from the school library.....	F	O	N
Arranged a date for another student.....	F	O	N
Overslept and missed a class or appointment.....	F	O	N
Typed a homework assignment.....	F	O	N
Discussed my future with my parents.....	F	O	N
Failed to complete a homework assignment on time..	F	O	N
Argued with a teacher in class.....	F	O	N
Attended a religious service.....	F	O	N
Participated in a demonstration against the war in Viet Nam.....	F	O	N
Participated in a demonstration against racial discrimination.....	F	O	N
Participated in a demonstration against some administrative policy of my school.....	F	O	N
Did extra (unassigned) reading for a course.....	F	O	N
Took sleeping pills.....	F	O	N
Tutored another student.....	F	O	N
Played chess.....	F	O	N
Read poetry not connected with a course.....	F	O	N
Took a tranquilizing pill.....	F	O	N
Discussed religion.....	F	O	N
Took vitamins.....	F	O	N
Visited an art gallery or museum.....	F	O	N
Worked in a school political campaign.....	F	O	N
Worked in a local, state, or national political campaign.....	F	O	N
Missed school because of illness.....	F	O	N
Smoked cigarettes.....	F	O	N
Discussed politics.....	F	O	N
Drank beer.....	F	O	N
Discussed sports.....	F	O	N
Asked a teacher for advice after class.....	F	O	N
Had vocational counseling.....	F	O	N
Stayed up all night.....	F	O	N

24. Indicate the importance to you personally of the following persons or events in your decision to enroll in this college. (Mark one for each item)

	Major Influence	Minor Influence	Not Relevant
Parent or other relative.....	<input type="radio"/>	<input type="radio"/>	<input type="radio"/>
High school teacher or counselor.....	<input type="radio"/>	<input type="radio"/>	<input type="radio"/>
Friends attending this college.....	<input type="radio"/>	<input type="radio"/>	<input type="radio"/>
Graduate or other representative from this college.....	<input type="radio"/>	<input type="radio"/>	<input type="radio"/>
Professional counseling or college placement service.....	<input type="radio"/>	<input type="radio"/>	<input type="radio"/>
Athletic program of the college.....	<input type="radio"/>	<input type="radio"/>	<input type="radio"/>
Other extracurricular activities.....	<input type="radio"/>	<input type="radio"/>	<input type="radio"/>
Social life of the college.....	<input type="radio"/>	<input type="radio"/>	<input type="radio"/>
Opportunity to live away from home.....	<input type="radio"/>	<input type="radio"/>	<input type="radio"/>
Low cost.....	<input type="radio"/>	<input type="radio"/>	<input type="radio"/>
Academic reputation of the college.....	<input type="radio"/>	<input type="radio"/>	<input type="radio"/>
Most of the students are like me.....	<input type="radio"/>	<input type="radio"/>	<input type="radio"/>
Religious affiliation.....	<input type="radio"/>	<input type="radio"/>	<input type="radio"/>

25. Indicate the importance to you personally of each of the following: (Mark one for each item)

	Essential	Very Important	Somewhat Important	Not Important
Becoming accomplished in one of the performing arts (acting, dancing, etc.).....	E	V	S	N
Becoming an authority on a special subject in my subject field.....	E	V	S	N
Obtaining recognition from my colleagues for contributions in my special field.....	E	V	S	N
Becoming an accomplished musician (performer or composer).....	E	V	S	N
Becoming an expert in finance and commerce.....	E	V	S	N
Having administrative responsibility for the work of others.....	E	V	S	N
Being very well-off financially.....	E	V	S	N
Helping others who are in difficulty.....	E	V	S	N
Participating in an organization like the Peace Corps or Vista.....	E	V	S	N
Becoming an outstanding athlete.....	E	V	S	N
Becoming a community leader.....	E	V	S	N
Making a theoretical contribution to science.....	E	V	S	N
Writing original works (poems, novels, short stories, etc.).....	E	V	S	N
Never being obligated to people.....	E	V	S	N
Creating artistic work (painting, sculpture, decorating, etc.).....	E	V	S	N
Keeping up to date with political affairs.....	E	V	S	N
Being successful in a business of my own.....	E	V	S	N
Developing a meaningful philosophy of life.....	E	V	S	N

26. Mark one in each row:

	Agree strongly	Agree somewhat	Disagree somewhat	Disagree strongly
Students should have a major role in specifying the college curriculum.....	<input type="radio"/>	<input type="radio"/>	<input type="radio"/>	<input type="radio"/>
Scientists should publish their findings regardless of the possible consequences.....	<input type="radio"/>	<input type="radio"/>	<input type="radio"/>	<input type="radio"/>
Realistically, an individual person can do little to bring about changes in our society.....	<input type="radio"/>	<input type="radio"/>	<input type="radio"/>	<input type="radio"/>
College officials have the right to regulate student behavior off campus.....	<input type="radio"/>	<input type="radio"/>	<input type="radio"/>	<input type="radio"/>
The chief benefit of a college education is that it increases one's earning power.....	<input type="radio"/>	<input type="radio"/>	<input type="radio"/>	<input type="radio"/>
Faculty promotions should be based in part on student evaluations.....	<input type="radio"/>	<input type="radio"/>	<input type="radio"/>	<input type="radio"/>
My beliefs and attitudes are similar to those of most other students.....	<input type="radio"/>	<input type="radio"/>	<input type="radio"/>	<input type="radio"/>
Student publications should be cleared by college officials.....	<input type="radio"/>	<input type="radio"/>	<input type="radio"/>	<input type="radio"/>
Marijuana should be legalized.....	<input type="radio"/>	<input type="radio"/>	<input type="radio"/>	<input type="radio"/>
Current levels of air pollution in large cities justify the use of drastic measures to limit the use of motor vehicles.....	<input type="radio"/>	<input type="radio"/>	<input type="radio"/>	<input type="radio"/>
Urban problems cannot be solved without huge investments of Federal money.....	<input type="radio"/>	<input type="radio"/>	<input type="radio"/>	<input type="radio"/>
Cigarette advertising should be outlawed on radio and TV.....	<input type="radio"/>	<input type="radio"/>	<input type="radio"/>	<input type="radio"/>
College officials have the right to ban persons with extreme views from speaking on campus.....	<input type="radio"/>	<input type="radio"/>	<input type="radio"/>	<input type="radio"/>
Only volunteers should serve in the armed forces.....	<input type="radio"/>	<input type="radio"/>	<input type="radio"/>	<input type="radio"/>
Students from disadvantaged social backgrounds should be given preferential treatment in college admissions.....	<input type="radio"/>	<input type="radio"/>	<input type="radio"/>	<input type="radio"/>
Most college officials have been too lax in dealing with student protests on campus.....	<input type="radio"/>	<input type="radio"/>	<input type="radio"/>	<input type="radio"/>

References

- Astin, A. W. "Why We Need Your Number." Paper presented at the Annual Meeting of the American Personnel and Guidance Association, Detroit, 1968.
- American Psychological Association. Casebook on Ethical Standards of Psychologists. Washington, D.C.: American Psychological Association, 1967.
- American Association of University Professors. "Joint Statement on Rights and Freedoms of Students." AAUP Bulletin. Summer 1968, pp. 258-261.
- Association for Computing Machinery. "Professional Conduct in Information Processing." Communications of the ACM. Vol. 2, No. 3, March 1968.
- Bayer, A.E., Astin, A.W., Boruch, R.F., Creager, J.A. "User's Manual." ACE Research Reports. Vol. 4, No.1, Washington, D.C.: American Council on Education, 1969.
- Banzhaf, J.F. "When Your Computer Needs a Lawyer." Communications of the ACM. Vol. 2, No. 8, August 1968.
- Bradburn, N.M. "Organizational Cooperation and the Problems of Privacy." Paper presented at the Annual Meeting of the American Personnel and Guidance Association, Detroit, 1968.
- The Carnegie Commission. The Carnegie Commission Report. New York, 1968.
- Creager, J.A., Astin, A.W., Boruch, R.F., Bayer, A.E. "The National Norms for Entering College Freshmen-Fall 1968." ACE Research Reports. Vol. 3, No. 1, Washington, D.C.: American Council on Education, 1969.
- Cronbach, L.J. Essentials of Psychological Testing. New York: Harper and Row, 1949.

- Dunn, E.S. "The Idea of a National Data Center and the Issue of Personal Privacy." The American Statistician. Vol. 21, No. 1, February, 1967, pp. 21-27.
- Fanwick, Charles. "Computer Safeguards: How Safe Are They?" SDC Magazine. Vol. 10, 1967, pp. 26-28.
- Hartnett, R.T., and Seligsohn, H.C. "The Effects of Varying Degrees of Anonymity on Responses to Different Types of Psychological Questionnaires." Journal of Educational Measurement. Vol. 4, No. 2, Summer 1967, pp. 95-103.
- Hoch, E.L. "The Privacy Issue and a Professional Response at the Departmental Level." Journal of Educational Measurement. Vol. 4, No. 1, Spring 1967, pp. 17-22.
- National Educational Association. "Code of Ethics of the Education Profession." Washington, D.C.: National Educational Association, July, 1968.
- Nichols, David. "Research Uses of Large Data Files Collected in Operational Programs." Paper presented at the Annual Meeting of the American Personnel and Guidance Association, Detroit, 1968.
- Peterson, R.E. "Notes on Respondent Rights in Social Research." Paper presented at the Annual Meeting of the American Personnel and Guidance Association, Detroit, 1968.
- "Privacy and Behavioral Research." Science. Vol. 155, February 3, 1967, pp. 535-538.
- Research Advisory Committee on Campus Unrest. "Statement on Confidentiality Use of Results, and Independence by the Advisory Committee A.C.E. Study of Campus Unrest." Science. Vol. 165, No. 3889, July, 1969, pp. 158-159.

- Ruebhausen, O.M., and Brim, O.G. "Privacy and Behavioral Research."  
Columbia Law Review. Vol. 65, 1965, pp. 1184-1211.
- Sawyer, Jack, and Schechter, Howard. "Computers, Privacy, and the  
National Data Center: The Responsibility of Social Scientists."  
American Psychologist. Vol. 23, No. 11, November, 1968.
- Solomon, Herbert. "Jurimetrics Revisited." Paper presented at the Washington  
Statistical Society Meeting, Washington, D. C., October 30, 1968.
- U.S. Department of Defense. Industrial Security Manual for Safeguarding  
Classified Information. DOD 5220, 22-M. Washington, D.C.: Depart-  
ment of Defense, July 1, 1966.
- U.S. Department of Health, Education and Welfare. Research in Education.  
Washington, D.C.: U.S. Government Printing Office, 1968.
- U.S. Department of Health, Education and Welfare. Public Health Service.  
"Protection of the Individual as a Research Subject--Grants, Awards,  
Contracts.: Washington, D.C. : U.S. Government Printing Office,  
May, 1969.
- Weismann, Clark. "Programming Protection: What Do You Want to Pay?" SDS  
Magazine. Vol. 10, No. 7, July, 1967, pp. 30-31.
- Westin, A.F. Privacy and Freedom. New York: Atheneum, 1967.
- Willingham, W.W. "Invasion of Privacy in Research and Testing." Journal  
of Educational Measurement. (Supplement), Vol. 4, 1967, pp. 1-31.

Other recent publications by the staff of the Office of Research:

- Alternative Methods of Describing Characteristics of Colleges and Universities**  
John A. Creager and Alexander W. Astin  
*Educational and Psychological Measurement*, 28, 1968, 719-734
- A Program of Research on Student Development**  
Alexander W. Astin  
*The Journal of College Student Personnel*, 1968, 299-307
- Criteria of Student Development**  
Robert J. Panos  
*The Journal of College Student Personnel*, 1968, 308-311
- General Purpose Sampling in the Domain of Higher Education**  
John A. Creager  
*ACE Research Reports*, 3(2), 1968
- Interregional Migration and the Education of American Scientists**  
Alan E. Bayer  
*Sociology of Education*, 41, 1968, 88-102
- National Norms for Entering College Freshmen—Fall 1968**  
John A. Creager, Alexander W. Astin, Robert F. Boruch, Alan E. Bayer  
*ACE Research Reports*, 3(1), 1968
- Personal and Environmental Determinants of Student Activism**  
Alexander W. Astin  
*Measurement and Evaluation in Guidance*, 1(3), 1968, 149-162
- Sex Differences in Academic Rank and Salary Among Science Doctorates in Teaching**  
Alan E. Bayer and Helen S. Astin  
*Journal of Human Resources*, 3, 1968, 191-200
- The College Drop-out: Factors Affecting Senior College Completion**  
Alan E. Bayer  
*Sociology of Education*, 41, 1968, 305-316
- The College Environment**  
Alexander W. Astin  
American Council on Education, 1968
- The Effect of International Interchange of High Level Manpower on the United States**  
Alan E. Bayer  
*Social Forces*, 46, 1968, 465-477
- Undergraduate Achievement and Institutional "Excellence"**  
Alexander W. Astin  
*Science*, 161, 1968, 661-668
- Use of Research Results in Matching Students and Colleges**  
John A. Creager  
*The Journal of College Student Personnel*, 1968, 312-319
- A Preliminary Evaluation of the Undergraduate Research Participation Program of the National Science Foundation**  
Alexander W. Astin  
*The Journal of Educational Research*, 62, 1969, 217-221
- The Black Student in American Colleges**  
Alan E. Bayer and Robert F. Boruch  
*ACE Research Reports*, 4(2), 1969
- The Educational and Vocational Development of College Students**  
Alexander W. Astin and Robert J. Panos  
American Council on Education, 1969
- Users' Manual—ACE Higher Education Data Bank**  
Alan E. Bayer, Alexander W. Astin, Robert F. Boruch, John A. Creager  
*ACE Research Reports*, 4(1), 1969