

EFFECT OF ELEMENTS ON LINEAR ELASTIC STRESS ANALYSIS: A FINITE ELEMENT APPROACH

Wai Chee Mun¹, Ahmad Rivai², Omar Bapokutty³

¹Postgraduate Student, ²Associate Professor, ³Senior Lecturer, Faculty of Mechanical Engineering, Universiti Teknikal Malaysia Melaka (UTeM), Melaka, Malaysia
cmwai@live.com.my, ahmadrivai@utem.edu.my, omarbapokutty@utem.edu.my

Abstract

The question of “what type of elements should be used?” never fails to pop up in the minds of analysts when carrying out finite element analysis (FEA). Indeed, the selection of elements from a variety of different types of elements is part and partial of FEA. Initially, only one-dimensional (1D) elements were developed. The introduction of two-dimensional (2D) and three dimensional (3D) elements, which came later, greatly increase the capability of finite element (FE) programs to model and solve complex engineering problems. Not only do these elements provide improvement in accuracy of the results but also brought about new challenges which include evaluation of numerical errors, validity of results, setup and execution time as well as large computer memory capacity. The outcome of the analysis is very much dependent of the type of element chosen. The aim of this paper is to investigate the factors influencing the selection of elements in FEA by considering the effects of different types of elements on the results of FEA. A simple case study of an I-beam subjected to an asymmetric load is carried out by FEA. Three different models of the I-beam were prepared and analyzed separately using 1D elements, 2D elements, and 3D elements. The results of these models were compared with the mathematical model of the I-beam. The FEA results of these models showed good agreement with the theoretical calculation despite the small and negligible errors in the analysis. Since the aim of FEA is an effective and efficient solution to engineering problems, it becomes a necessity to consider factors such as structural shape, desired analysis results, and computer capability while choosing the right element for the analysis.

Keywords: Finite Element Analysis (FEA), Modeling, Stress Analysis, and Linear Static Analysis.

1. INTRODUCTION

The popularity of finite element analysis (FEA) in the industry, especially aircraft [1], automotive [2-4], and even civil engineering, has now spread to the academics [4-7]. Though FEA was created to analyze complicated engineering structures, it is now also used in research to study simple structural behavior [7, 8] and predict material properties [9].

FEA is the practical application of finite element method (FEM), which is an alternative method to solve engineering problems numerically [10-14]. Often, the governing equations for a structural problem, especially engineering structures, are very complicated. The solution of these sophisticated mathematical models is very tedious and sometimes near impossible. The FEM breaks down the structure into small but finite pieces called elements. Equations are formulated for each element and the results are combined to obtain the final solution to the engineering problem [11-13]. The outcome of the FEA is therefore greatly influence by the skill of the analyst to select the right type of element to represent the structure. Unfortunately, the ability to select elements for effective modeling and analysis is usually gained through experience and seldom discussed in literature.

Since the discussion and also the analytical model to justify the effects of elements in FE modeling is lacking, this paper aims to investigate the factors influencing the selection of elements in FEA by considering the effects of different types of elements on the results of FEA. Since there are many different types of elements which, are developed independently and vary from one finite element (FE) software to another, the scope of this research is limited to the similarities and differences between one dimensional (1D) elements, two dimensional (2D) elements, and three dimensional (3D) elements.

2. TYPES OF FINITE ELEMENTS

Though there are different types of elements with various shapes, elements in FEA are generally grouped into one 1D element, 2D elements, and 3D elements. They are recognized based on their shapes. For example, elements can take on the form of a straight line or curve, triangle or quadrilateral, tetrahedral and many more. The simplest element is a line made of two nodes. All line elements, whether straight or curved, are called 1D element [10, 11]. Examples of 1D element are truss element and beam element [4, 12].

2D elements are surface elements with triangle or quadrilateral as their basic shapes [11, 13, 14]. Examples of 2D elements are 3-node triangular element and 6-node triangular element [12]. These surface elements can have either regular or irregular shapes shown in Fig -1. 2D elements are plane elements. They are often used to solve 2D elasticity problems [5, 8, 14].

3D elements are usually used to mesh volumes [10-12]. They are derived from 2D elements and are used when the volume of the structure cannot be neglected [8]. Generally 3D elements have quadrilateral or hexagonal shape. Examples of 3D solid elements are 4-node tetrahedral element, 10-node tetrahedral element, 8-node isoparametric element, etc [12].

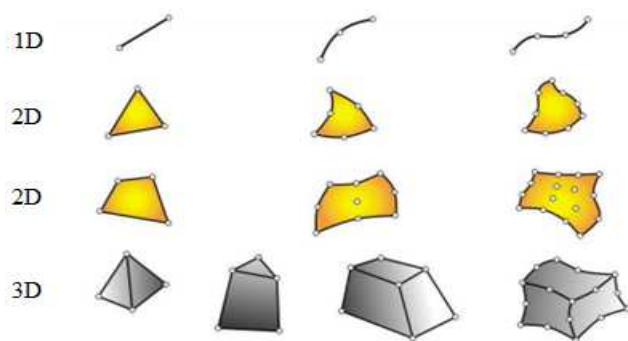

Fig -1: Typical finite element geometries [15].

3. MODELING AND VALIDATION

A wide flange beam, W460x74 [16], is subjected to an eccentric load of 1000 kN shown in the Fig -2. The load is applied to one end of the beam about 200 mm from the neutral axis of the beam. The other end of the beam is assumed to be fixed with no translational or rotational displacements. The cross section of the beam and its configuration is also illustrated in Fig -2. The beam is given steel properties. Table -1 contains the necessary dimensions and material properties [16] of the beam.

Table -1: Wide flange beam W460x74 dimensions and its properties

Dimension	
L (mm)	5000.00
H (mm)	457.00
t (mm)	9.00
t1 (mm)	14.50
t2 (mm)	14.50
W1(mm)	190.00
W2 (mm)	190.00
Properties	
Young's Modulus (N/mm ²)	200000.00
Poisson ratio	0.30

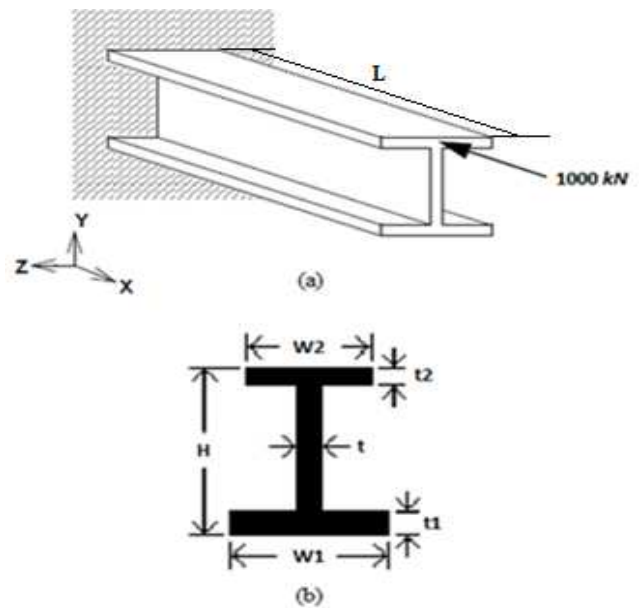

Fig -2: (a) Wide flange beam W460x74 subjected to an eccentric load; (b) Cross section of wide flange beam, W460x74 [17].

Three case studies were carried out separately on the beam using 1D element, 2D element, and 3D element as shown in Fig -3. Commercial FEA software, namely MSC Patran and MD Nastran, were utilized for the purpose of this research.

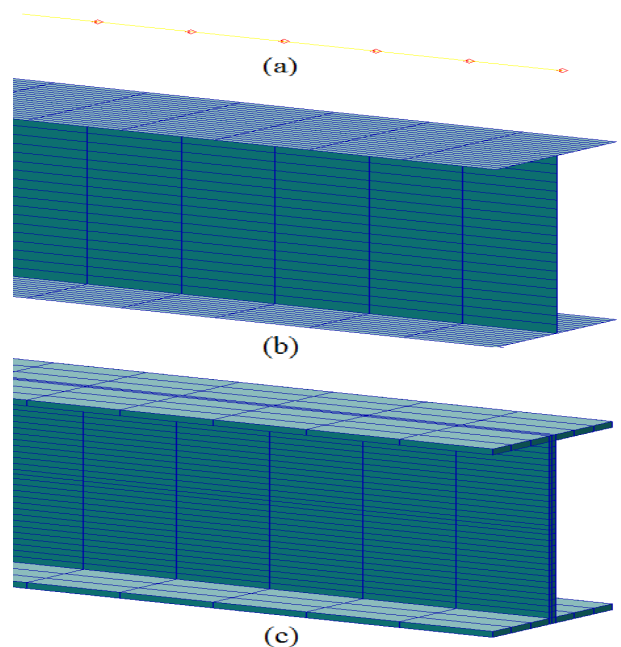

Fig -3: FE model of wide flange beam W460x74 using: (a) 1D element; (b) 2D element; (c) 3D element

In order to compare the memory and execution time of the solver, the finite elements used are of the same global edge length which is 100 mm. Since the load is applied 200 mm from the neutral axis of the beam, the load can be decomposed into an equivalent compressive force of 1000 kN and moment of 200 MNmm at the centroid of the beam. The same loading condition is applied to all three FE models of the beam to eliminate the effect of loading conditions on the choice of elements.

The FE models of the wide flange beam W460x74 are verified by comparing the results of FEA with the solution of the beam mathematical model. Theoretical calculations of the beam stresses and displacement are done using Equations (1-6) [16] with dimensions and properties as mentioned in Table -1. Table -2 shows the comparison between FEA results with theoretical calculation. It is proven that the results of FEA for all three FE models are in good agreement with theoretical calculation. Therefore, all the FE models are considered valid and can be used for this study.

$$\sigma_n = \frac{F}{A} \tag{1}$$

$$\sigma_m = \frac{Mc}{I} \tag{2}$$

$$\sigma_T = \frac{F}{A} + \frac{Mc}{I} \tag{3}$$

$$\delta_n = \frac{FL}{AE} \tag{4}$$

$$\delta_m = \frac{ML^2}{2EI} \tag{5}$$

$$\delta_T = \sqrt{(\delta_n)^2 + (\delta_m)^2} \tag{6}$$

Where, F is the axial load, M is bending moment, A is the beam cross sectional area, I is the beam second moment of area, σ_n is the normal stress, σ_m is the bending stress, σ_T is the maximum stress due to the applied load, δ_n is the deflection of the beam from axial load, δ_m is the deflection of the beam from bending moment, δ_T maximum deflection of the beam.

Table -2: Comparison between FEA and theoretical calculation of stresses and displacement for wide flange beam W460x74

Results	Theory	FE Model		
		1D	2D	3D
Maximum Tensile Stress (MPa)	32.251	32.300	32.248	31.895
Maximum Compressive Stress (MPa)	245.881	246.000	245.703	245.573

Maximum Beam Deflection (mm)	38.132	38.100	38.400	38.400
------------------------------	--------	--------	--------	--------

4. RESULTS

Table -3 shows the comparison of FEA results available for 1D FE model, 2D FE model, and 3D FE model for wide flange beam W460x74. Stress results for 1D FEA are available in the form of bar stresses and are neatly organized into axial stresses, bending stresses, and combined axial and bending stresses. Axial stresses are stresses due to the force acting normal to the surface while bending stresses are stresses due to moment. Combined axial and bending stresses are further divided into minimum and maximum combined stresses. Stresses for 2D FE model and 3D FE model are displayed in the form of stress tensor. Stresses such as axial stresses, bending stresses and combined axial and bending stresses must be perceived and interpreted by the analyst through the stress tensor.

Table -3: Comparison of FEA results between 1D FE model, 2D FE model, and 3D FE model

Analysis Results	FE Model		
	1D	2D	3D
Stress tensor	NA	Available	Available
Bar stresses, Axial	Available	NA	NA
Bar stresses, Bending	Available	NA	NA
Bar stresses, Max combined	Available	NA	NA
Bar stresses, Min combined	Available	NA	NA
Displacement	Available	Available	Available
Deformation	Available	Available	Available

Both displacement results and deformation for 1D FE model, 2D FE model, and 3D FE model are available as resultant or as separate components in the x-axis, y-axis, and z-axis directions. Table -4 displays the deflection of the beam in the y-axis due to the applied load.

Table -4: Deflection of wide flange beam W460x74 at different beam length

Length of Beam, x (mm)	Deflection of Beam, y (mm)			
	Theory	1D	2D	3D
500	0.4648	0.4648	0.4523	0.4442
1000	1.6125	1.6125	1.5943	1.5783
1500	3.5159	3.5159	3.4920	3.4690
2000	6.1790	6.1790	6.1496	6.1183
2500	9.6027	9.6027	9.4745	9.5300
3000	13.7869	13.7870	13.5677	13.6997
3500	18.7319	18.7320	18.6859	18.6329

4000	24.4376	24.4377	24.3861	24.3236
4500	30.9040	30.9041	30.8470	30.7801
5000	38.1311	38.1313	38.0351	38.0020

The deflection is taken at 10 different but constant increment of the length of the beam. Theoretical values of the beam displacement are obtained using Equation (7) [16].

$$\delta_y = \frac{ML}{EI} \tag{7}$$

Where δ_y is the deflection at the end of the beam, M is bending moment, L is the total length of the beam, E is the Young's Modulus of the beam, I is the beam second moment of area.

It is shown in Table -4 that the deflection of the beam in the y-axis obtained from 1D FE model is closest to the theoretical value. The deflection of the beam in the y-axis obtain from 2D FE model and 3D FE model, although close to each other values, vary slightly from the theoretical value. The deflection of the beam is plotted against the length of the beam in Fig -4. It is seen in Fig -4 that the curves of 1D FE model, 2D FE model, and 3D FE model coincides with the theoretical curve. This shows that the errors are small and can be neglected.

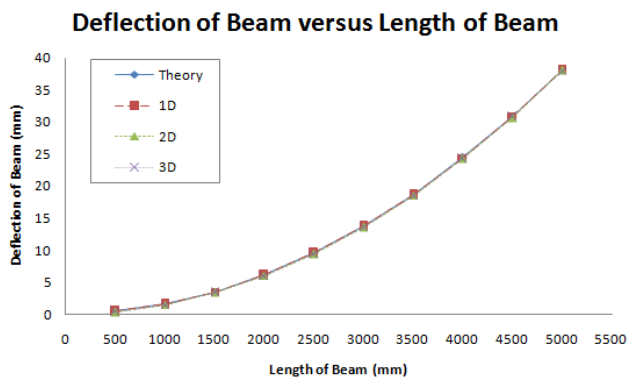

Fig -4: Wide flange beam W460x74 deflection at different length of beam

Fig -5 shows the manner in which the beam deforms under the influence of the load. 3D FE model gives a better illustration of deformation of the beam than that of 2D FE model. 1D FE model gives the simplest illustration of the beam deformation as the beam is modeled as a line at the neutral axis of the actual beam. The cross section of the beam is then applied to the 1D element. All 3 FE models of the beam show that the beam bends upwards due to the asymmetric loading.

The stress distribution in the beam due to the applied load is shown clearly in 2D FE model and 3D FE model of the beam. However, this cannot be observed in 1D FE model. Fig -6 shows the stress distribution of all the 3 FE model of the

beam. The fringe indicates minimum stress increasing to maximum stress from blue to red colour respectively. Since the load causes an upward bending, the top surface of the beam will experience compression while the bottom surface experience tension. Referring to Equation (3), the bottom surface will experience minimum stress while the top surface experience maximum stress. This is correctly indicated by the colors of the fringe in 2D FE model and 3D FE model. However, the maximum stress at the top surface of the beam is indicated by green colour instead of red.

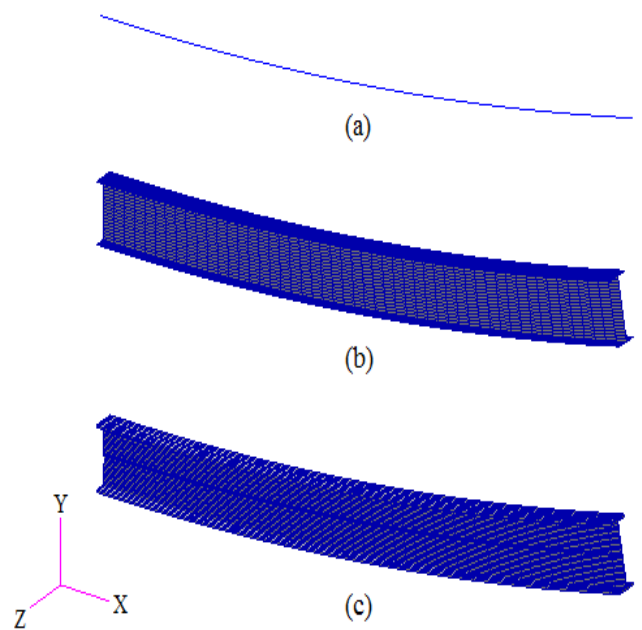

Fig -5: Deformation of wide flange beam W460x74: (a) 1D FE model; (b) 2D FE model; (c) 3D FE model

The colour red is located at a small spot at the top end of the beam. This indicates the stress concentration area where stress is multiplied several times of the maximum stress. Coincidentally, this stress concentration area is also the area where the load is applied. According to Saint Venant's principle [16, 18-20], elements near the points of load application are expected to experience very large stresses while stress distribution for the rest of the cross section of the beam may be assumed independent of the actual mode of load application.

The Saint Venant's phenomenon of stress concentration due to static loading can also be explained by Equation (1). If the area of load application is reduced, the stress at that area increases. Hence, if the area approaches zero, the stress become infinite. Therefore, the maximum stress of the beam is computed at the top surface according to the Flexure formula [20].

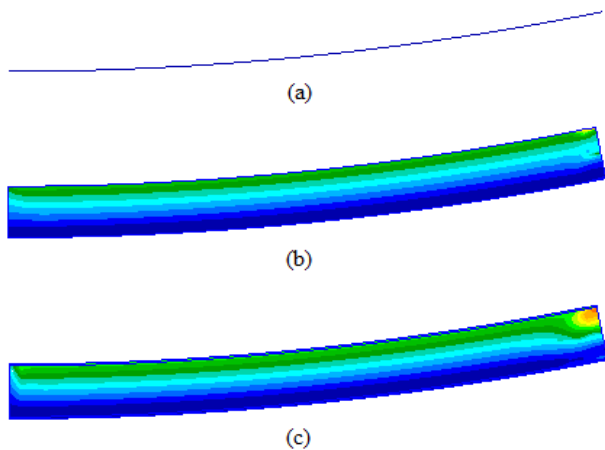

Fig -6: Stress distribution and deformation of wide flange beam W460x74 (side view): (a) 1D FE model; (b) 2D FE model; (c) 3D FE model

Table -5 shows the execution time and computer memory required to run the analysis of 1D FE model, 2D FE model, and 3D FE model. 3D FE model takes up the most memory and the longest execution time. 1D FE model used the least computer memory and requires the shortest execution time.

Table -5: Memory Usage and Execution Time of FE Model

	FE Model		
	1D	2D	3D
Memory usage (mb)	15.219	97.125	163.031
Execution time (s)	2.770	5.660	10.795

5. DISCUSSION

The errors in FEA results of 1D FE model, 2D FE model, and 3D FE model are due to the different “characteristics” of 1D elements, 2D elements and 3D elements. These “characteristics” are simply different assumptions made in the computation of the elements. The mathematical model to compute stresses and deformation of beam presented in most undergraduate textbooks, such as Beer [16], Mott [18], and Young [19], is that of the assumptions of 1D elements. Therefore, the results of 1D FEA are very similar to those obtained by theoretical calculation. For example, a beam in compression will experience uniform decrement in length and increment in width throughout the member regardless of the mode of load application. Clearly, this assumption has been proven flawed by Saint Venant’s principle. 2D and 3D elements, which consider plane stresses such as shear stress, produce stresses and displacement values which deviate slightly from the solution of 1D mathematical model. However, to overcome the phenomenon of Saint Venant’s principle, an improved method of load application should be adapted.

Due to the consideration of plane stresses in 2D and 3D elements, the results obtained are more detail in terms of stress distribution and displacement. The interpretation and extraction of FEA results for 2D FE model and 3D FE model also become more tedious compared to 1D FE model. The importance of the detail results in 2D and 3D FEA is the identification of location of stress concentration which may cause fatal failure of the structure.

In terms of accuracy, all three FE models which, are 1D FE model, 2D FE model, and 3D FE model, display reliable FEA results. Since FEA is a numerical method, it is expected to have small but acceptable errors. Although 1D elements, 2D elements, and 3D elements have different characteristics, the small errors in their FEA results proved that the accuracy of the FEA results is dependent on the element size, which is defined by the global edge length. The quality of the mesh has to be refined until a mesh independent result is obtained.

The choice of elements for FEA, therefore, depends largely on the geometry of the structure. Not all structures can be modeled using 1D element or 2D element. 1D element is used for long and slender symmetrical structure with uniform cross section. 2D element is used for plate or shell like structure while 3D element is used for structure with complex geometry which cannot be simplified for analysis.

Since the form of FEA result is very much influenced by the type of elements, the desired analysis result becomes one of the deciding factor for the selection of elements in the early stage of FE modeling. If a detail analysis in which the stress distribution due to the applied load is required, then 2D element or 3D element are of better choices. 1D element, however, can still be used for rough and quick estimation of overall factor of safety for the engineering structure.

Lastly, the choice of element for FEA also depends on the analysis time and memory capacity of the computer available. Since all three FE models produced reliable FEA results, the execution time and computer memory becomes the deciding factor. It is always better to carry out the analysis in the shortest amount of time with the smallest computer memory required so that the engineering problem can be solved effectively and efficiently. In this case, modeling with 1D elements is the best choice followed by 2D elements and lastly, 3D elements.

CONCLUSIONS

Two important parameters in linear static analysis in FEA are stress and displacement. The results, however, might differ depending on the types of element used for modeling. The difference is due to the different characteristics inherent by different elements. Therefore, it is crucial to understand the characteristic of the elements in order to optimize modeling to achieve accurate and reliable FEA results. However, since the

type of FE elements differ from one FE software to another, it is too immense to cover all the different elements available in all the different commercial software available.

With the advantages and limitations of these elements in mind, three factors are to be considered when deciding on the types of elements to be used in FEA, which are the geometry of the structure, desired analysis results, and analysis time frame as well as the capability of the computer.

The most important factor is the geometry of the structure. 1D elements are used for simple analysis of symmetrical and slender structure. Normally, 2D elements are sufficient for most of the engineering problems. 3D elements should only be used if the structure has complex geometry and is unable to be simplified.

Next factor to be considered is the results required. If it is just simple and quick analysis on the structural integrity, 1D element is the right choice. 2D element and 3D element are used for detail results such as determination of stress distribution, while 1D element is used for rough estimate.

Last but not least is the execution time and memory required for the solver to run the analysis. If the limitation is on the analysis time and computer memory, 1D element is the best choice. If a large computer memory is available, modeling with 2D element or 3D element is better in the sense that it gives a detail FEA result.

ACKNOWLEDGEMENTS

The authors would like to acknowledge CRIM, and Faculty of Mechanical Engineering, Universiti Teknikal Malaysia Melaka (UTeM) for supporting the present work through PJP/2012/FKM(18C)S1112 Research Fund.

REFERENCES

- [1]. Soutis, C, Carbon fiber reinforced plastics in aircraft construction, *Materials Science and Engineering A*. 412 (2005) 171-176.
- [2]. A. Aronsson, Design, Modelling and Drafting of Composite Structures, Master of Science Thesis, Lulea University of Technology, 2005.
- [3]. H. Karlsson, Evaluation of FE-software for Analysis of Composite Materials, Master of Science Thesis, Lulea University of Technology, 2005.
- [4]. E. Arnoult, P. Lardeur, L. Martini, The modal stability procedure for dynamic and linear finite element analysis with variability, *Finite Elements in Analysis and Design*. 47 (2011) 30-45.
- [5]. V.V. Kuznetsov, S.V. Levyakov, Geometrically nonlinear shell finite element based on the geometry of a planar curve, *Finite Elements in Analysis and Design*. 44 (2008) 450-461.
- [6]. C. Veyhl, I.V. Belova, G.E. Murch, A. Ochsner, T. Fiedler, On the mesh dependence of non-linear mechanical finite element analysis, *Finite Elements in Analysis and Design*. 46 (2010) 371-378.
- [7]. Y.X. Zhang, & C.H. Yang, Recent developments in finite element analysis for laminated composite plates, *Composite Structures*. 88 (2009) 147-157.
- [8]. Tulay Aksu Ozkul, Nail Kara, Nahit Kumbasar, The transition from moderately thick shells to thick shells of general shape by using finite element analysis, *Finite Elements in Analysis and Design*. 43 (2007) 247-260.
- [9]. P.R. Lakshmi, & P.R. Reddy, Investigation of interlaminar shear strength in carbon epoxy and carbon epoxy carbon nanotubes using experimental and finite element technique, *International Journal of Engineering Research and Applications (IJERA)*. 2 (2012) 001-010.
- [10]. M.A. Bathi, *Fundamental Finite Element Analysis and Applications with Mathematica® and Matlab® Computations*, John Wiley & Sons, Inc., USA, 2005.
- [11]. D.L. Logan, *A First Course in The Finite Element Method*, fourth ed., Thomson Canada Limited, Canada, 2007.
- [12]. P. Rugarli, *Structural Analysis with Finite Elements*. Thomas Telford Limited, United Kingdom, 2010.
- [13]. A. Berlioz, P. Trompette, *Solid Mechanics Using The Finite Element Method*, John Wiley & Sons, Inc., United States of America, 2010.
- [14]. D. Chapelle, K.J. Bathe, *The Finite Element Analysis of Shells – Fundamentals*, second ed., Springer, New York, 2011.
- [15]. P. Boeraeve, *Introduction to the finite element method (FEM)*, (2010). www.gramme.be/unite9/FEM/Finite%20Element%20Method.pdf
- [16]. F.P. Beer, E.R. Johnston, Jr., J.T. DeWolf, *Mechanics of Materials*, fourth ed., McGraw-Hill Education, Singapore, 2006.
- [17]. MSC (MSC Software Corporation), *MSC.Nastran 105 exercise workbook*.
- [18]. R.L. Mott, *Applied Strength of Materials*, fifth ed., PHI Learning Private Limited, New Delhi, 2009.
- [19]. W.C. Young, R.G. Budynas, A.M. Sadegh, *Roark's Formulas for Stress & Strain*, eighth ed., McGraw-Hill, United States of America, 2012.
- [20]. W. Lacarbonara, A. Paolone, On solution strategies to saint-venant problem, *Journal of Computational and Applied Mathematics*. 206 (2007) 473-497.

BIOGRAPHIES



Wai Chee Mun is currently a postgraduate in Universiti Teknikal Malaysia Melaka. His is undertaking his research in the field of finite element analysis.



Ahmad Rivai is currently an associate professor teaching in the Faculty of Mechanical Engineering of Universiti Teknikal Malaysia Melaka.



Omar Bapokutty is currently a senior lecturer teaching in the Faculty of Mechanical Engineering of Universiti Teknikal Malaysia Melaka