

NASA TECHNICAL NOTE



NASA TN D-7396

NASA TN D-7396

LOAN COPY: RETURN
AFWL (SUL)
KIRTLAND AFB, N. M.

0133455



EFFECT OF INLET-AIR HUMIDITY,
TEMPERATURE, PRESSURE, AND
REFERENCE MACH NUMBER ON
THE FORMATION OF OXIDES OF NITROGEN
IN A GAS TURBINE COMBUSTOR

*by Nicholas R. Marchionna, Larry A. Diehl,
and Arthur M. Trout*

*Lewis Research Center
Cleveland, Ohio 44135*

NATIONAL AERONAUTICS AND SPACE ADMINISTRATION • WASHINGTON, D. C. • OCTOBER 1973





0133455

1. Report No. NASA TN D-7396		2. Government Accession No.	
4. Title and Subtitle EFFECT OF INLET-AIR HUMIDITY, TEMPERATURE, PRESSURE, AND REFERENCE MACH NUMBER ON THE FORMATION OF OXIDES OF NITROGEN IN A GAS TURBINE COMBUSTOR		5. Report Date October 1973	
		6. Performing Organization Code	
7. Author(s) Nicholas R. Marchionna, Larry A. Diehl, and Arthur M. Trout		8. Performing Organization Report No. E-7465	
9. Performing Organization Name and Address Lewis Research Center National Aeronautics and Space Administration Cleveland, Ohio 44135		10. Work Unit No. 501-24	
		11. Contract or Grant No.	
12. Sponsoring Agency Name and Address National Aeronautics and Space Administration Washington, D. C. 20546		13. Type of Report and Period Covered Technical Note	
		14. Sponsoring Agency Code	
15. Supplementary Notes			
16. Abstract <p>Tests were conducted to determine the effect of inlet-air humidity on the formation of oxides of nitrogen (NO_x) from a gas-turbine combustor. Combustor inlet-air temperature ranged from 506 K (450° F) to 838 K (1050° F). The tests were primarily run at a constant pressure of 6 atmospheres and reference Mach number of 0.065. The NO_x emission index was found to decrease with increasing inlet-air humidity at a constant exponential rate: $\text{NO}_x = \text{NO}_{x0} e^{-19H}$ (where H is the humidity and the subscript 0 denotes the value at zero humidity). The emission index increased exponentially with increasing normalized inlet-air temperature to the 1.14 power. Additional tests made to determine the effect of pressure and reference Mach number on NO_x showed that the NO_x emission index varies directly with pressure to the 0.5 power and inversely with reference Mach number.</p>			
17. Key Words (Suggested by Author(s)) Air pollution Combustion Humidity Exhaust gases Oxides of nitrogen Gas turbine engines		18. Distribution Statement Unclassified - unlimited	
19. Security Classif. (of this report) Unclassified	20. Security Classif. (of this page) Unclassified	21. No. of Pages 33	22. Price* Domestic, \$3.00 Foreign, \$5.50

EFFECT OF INLET-AIR HUMIDITY, TEMPERATURE, PRESSURE, AND
REFERENCE MACH NUMBER ON THE FORMATION OF OXIDES
OF NITROGEN IN A GAS TURBINE COMBUSTOR

by Nicholas R. Marchionna, Larry A. Diehl, and Arthur M. Trout

Lewis Research Center

SUMMARY

Tests were conducted to determine the effect of inlet-air humidity on the formation of oxides of nitrogen (NO_x) from a gas turbine combustor. Combustor inlet-air temperature ranged from 506 K (450° F) to 838 K (1050° F). Tests were primarily run at a constant pressure of 6 atmospheres and a reference Mach number of 0.065. Additional data were taken to determine the effect of pressure and reference Mach number.

The NO_x emission index decreased with increasing humidity at a constant exponential rate: $\text{NO}_{x} = \text{NO}_{x_0} e^{-19H}$ where H is the humidity (g of water/g of dry air) and the subscript 0 indicates the value at zero humidity.

The NO_x emission index increased exponentially with increasing normalized inlet-air temperature. At a constant pressure and reference Mach number the NO_x varied as $e^{1.14\theta}$, where θ is the normalized combustor inlet-air temperature based on standard day conditions.

For the range of test conditions investigated and at constant inlet and exit temperature and constant pressure, the NO_x emission index varied inversely with reference Mach number.

For the range of test conditions investigated and at constant inlet and exit temperature and constant reference Mach number, the NO_x emission index varied with pressure to the 0.5 power.

A NO_x number is derived which allows the prediction of NO_x emission index as a function of humidity, inlet-air temperature, pressure, and reference Mach number over the range of the test conditions for this combustor.

Combustion efficiency based on unburned hydrocarbon and carbon monoxide measurements was close to 100 percent at all test conditions, and it deviated only slightly from 100 percent at the lowest inlet-air temperature tested (506 K (450° F)). There was no significant effect due to humidity on smoke which was always below the visible limit at the test pressure of 6 atmospheres.

INTRODUCTION

The purpose of this report is to provide information concerning the effect of inlet-air humidity (g of water/g of dry air) on the exhaust gas emissions of oxides of nitrogen (NO_x) for gas-turbine type combustors.

Seasonal and geographic variations provide a wide variation in the amount of humidity in the ambient air. These variations are encountered by gas turbine engines for aircraft use and by stationary ground equipment. The humidity affects the formation of nitric oxide (NO) because it reduces the flame temperature upon which the formation of NO is strongly dependent. Moore (ref. 1) has made theoretical estimates of the effect of humidity on NO formation at a 1-atmosphere pressure and concluded that the effect was a 25-percent reduction for each mass percent of water vapor in the air.

After analyzing the data from many experimental tests, Lipfert (ref. 2) inferred that the effect of humidity was to reduce the NO_x 20 percent for each mass percent water vapor in the air. Correcting these data to a constant value of humidity, he was able to demonstrate a marked reduction in the apparent scatter of the NO_x data. He suggested that all future NO_x data be corrected to a constant value of humidity.

No systematic experimental study has been undertaken to determine the effect of humidity on NO_x . This information is needed before a realistic exhaust gas emissions standard can be established for pollution control.

The combustor used in these tests was designed for a turbojet engine burning ASTM Jet-A fuel. Water was added to the air supply system in order to vary the inlet air humidity up to a value of at least 0.043 gram of water per gram of dry air.

The combustor was operated over a range of conditions. Inlet-air temperature was varied from 506 K (450° F) to 838 K (1050° F). Most of the data were taken at a 6-atmosphere pressure and a combustor reference Mach number of 0.065. Additional data were taken at pressures of 6 and 4 atmospheres and reference Mach numbers of 0.073 and 0.080, respectively. The combustor was operated to give a nominal exit temperature of 1478 K (2200° F).

Emissions measurements were made of nitric oxide, total oxides of nitrogen, unburned hydrocarbons (H/C), carbon monoxide (CO), carbon dioxide (CO_2), and smoke.

FACILITY AND INSTRUMENTATION

Testing was conducted in a closed-duct test facility at the Lewis Research Center. A schematic of this facility is shown in figure 1. A detailed description of the facility and instrumentation are contained in reference 3. All fluid flow rates and pressures are controlled remotely.

Test Combustor

The test combustor, which was designed using the ram-induction approach, is described in reference 4. With the ram-induction approach the compressor discharge air is diffused less than it is in conventional combustors. The relatively high velocity air is captured by scoops in the combustor liner and turned into the combustion and mixing zones. Vanes are used in the scoops to reduce pressure loss caused by the high velocity turns. The high velocity and the steep angle of the entering air jets promote rapid mixing of both the fuel and air in the combustion zone and of the burned gases and air in the dilution zone. The potential result of rapid mixing is a shorter combustor or, alternatively, a better exit temperature profile in the same length.

A cross section of the combustor is shown in figure 2. The outer diameter is almost 1.07 meters (42 in.), and the length from compressor exit to turbine inlet is approximately 0.76 meter (30 in.). A snout on the combustor divides the diffuser into three concentric annular passages. The central passage conducts air to the combustor headplates, and the inner and outer passages supply air to the combustor liners. There are five rows of scoops on each of the inner and outer liners to turn the air into the combustion and dilution zones.

Photographs of the snout and the combustor liners are shown in figure 3. Figure 3(a) is a view looking upstream into the combustor liner. The scoops in the inner and outer liner and the openings in the headplate for the fuel nozzles and swirlers can be seen. Figure 3(b) is a view of the snout and the upstream end of the combustor liner. The V-shaped cutouts in the snout fit around struts in the diffuser. The circular holes through the snout walls are for the fuel nozzle struts. Figure 3(c) gives a closer view of the liner and headplate showing the fuel nozzles and swirlers in place. There are a total of 24 fuel nozzles in the combustor.

Water Addition

Water was sprayed into the air stream just downstream of the second heat exchanger as illustrated in figure 1. Two different spray nozzles were used to cover the range of flow conditions in order to provide good atomization. A photograph of the high range spray nozzle is shown in figure 4. Flow straighteners downstream of the water injection point ensured that the vaporized water mixed into the air stream.

The air flow was measured with an orifice stationed between the two heat exchangers. The humidity of the air at this point was also measured and taken into consideration in the calculations.

Exhaust Gas Temperatures

Combustor exhaust gas temperatures were measured at 3° increments around the circumference with three five-point aspirated thermocouple probes which traverse circumferentially in the exit plane. Five hundred eighty-five individual exit temperatures were used in each mass-weighted average exit temperature calculation. The exhaust gas temperature was used only as a check on combustion efficiency which was determined primarily by gas sampling measurements.

Exhaust Emissions

Concentrations of nitric oxide, total oxides of nitrogen, carbon monoxide, unburned hydrocarbons, and carbon dioxide were obtained with an online sampling system. The samples were drawn at the combustor exit as indicated in figure 2 from two circumferential locations and at five radial positions through water-cooled stainless steel probes as shown in figure 5.

Gas sample system. - A picture of the gas analysis instrumentation and a schematic of the system are shown in figures 6 and 7, respectively. The samples collected by the two sample probes were common manifolded to one sample line. Approximately 18 meters (60 ft) of 0.95-centimeter (3/8-in.) stainless steel line were used to transport the sample to the analytical instruments. In order to prevent condensation of water and to minimize adsorption-desorption effects of hydrocarbon compounds, the line was electrically heated to 428 K (310° F). Sample line pressure was maintained at 6.9 newtons per square centimeters (10 psig) in order to supply sufficient pressure to operate the instruments. Sufficient sample is vented at the instruments to provide a line residence time of about 2 seconds.

The exhaust gas analysis system is a packaged unit consisting of four commercially available instruments along with associated peripheral equipment necessary for sample conditioning and instrument calibration. In addition to visual readout, electrical inputs are provided to an IBM 360/67 computer for on-line analysis and evaluation of the data.

The hydrocarbon content of the exhaust gas is determined by a Beckman Instruments Model 402 Hydrocarbon Analyzer. This instrument is of the flame ionization detector type.

The concentration of the oxides of nitrogen is determined by a Thermo Electron Corporation Model 10A Chemiluminescent Analyzer. The instrument includes a thermal reactor to reduce NO_2 to NO and was operated at 973 K (1290° F).

Both carbon monoxide (CO) and carbon dioxide (CO_2) analyzers are of the nondispersive infrared (NDIR) type (Beckman Instruments Model 315B). The CO analyzer has four ranges: 0 to 100 ppm, 0 to 1000 ppm, 0 to 1 percent, and 0 to 10 percent. These

ranges of sensitivity are accomplished by using stacked cells of 0.64 centimeter (0.25 in.) and 34 centimeters (13.5 in.) in length. The CO₂ analyzer has two ranges: 0 to 5 percent and 0 to 15 percent, with a sample cell length of 0.32 centimeter (0.125 in.).

Analytical procedure. - All analyzers were checked for zero and span prior to the test. Solenoid switching within the console allows rapid selection of zero, span, or sample modes. Therefore, it was possible to perform frequent checks to ensure calibration accuracy without disrupting testing.

Where appropriate, the measured quantities were corrected for water vapor removed. The correction included both inlet-air humidity and water vapor from combustion. The equations used were obtained from reference 5.

The emission levels of all the constituents were converted to an emission index (EI) parameter. The EI may be computed from the measured quantities as proposed in reference 5; an alternate procedure is to use the metered fuel-air ratio when this is accurately known. When this latter scheme is used, the EI for any constituent X is given by

$$EI_X = \frac{M_X}{M_E} \frac{1+f}{f} [X] 10^{-3}$$

where

EI_X emission index in g of X per kg of fuel burned

M_X molecular weight of X

M_E average molecular weight of exhaust gas

f metered fuel-air ratio (g of fuel/g of wet air)

[X] measured concentration of X in ppm of exhaust gas

Both procedures yield identical results when the sample validity is good.

Smoke Number Measurement

The smoke sampling procedure as recommended in reference 6 was followed as closely as possible. The samples were drawn at the combustor exit plane as illustrated in figure 2 from one circumferential location at three radial positions through a water-cooled stainless steel probe similar to the gas sampling probe shown in figure 5 (except for the number of holes). The sample was transported to the filtering material (Whatman No. 4 filter paper) through approximately 4.5 meters (15 ft) of stainless steel line.

The sample rate through the filter was 2.36×10^{-4} cubic meters per second (0.50 ft³/min). The filter was placed on a black background tile to measure comparative reflectance using a Welch Densichron and Reflection unit (3832 A). A Welch Gray Scale (cat. no. 3827 T) was used as a calibration reference.

Test Conditions

Humidity in the ambient air can vary over a couple of orders of magnitude. Figure 8 is a semi-log plot of the humidity of saturated air as a function of temperature (ref. 7). To determine the effect of humidity on exhaust gas emissions, enough water was added to the air supply to raise the humidity to at least 0.043 gram of water per gram of dry air (to cover the range up to 100 percent relative humidity on a 311 K (100° F) day).

The nominal combustor operating conditions are listed in table I. For the initial tests, the inlet-air temperature was varied to determine whether the effect of humidity varied with inlet-air temperature. The reference Mach number was held constant for these tests since variations in Mach number produce variations in pressure drop, residence time, and mixing patterns. Additional data were taken to determine the effect of reference Mach number and combustor pressure on the formation of oxides of nitrogen.

The combustor inlet-air temperature was held constant while the water flow was increased by raising the exit temperature of the number 2 heat exchanger (fig. 1). Data were taken over a range of inlet-air temperatures from 506 to 838 K (450° to 1050° F). Because the exit temperature limit on the number 2 heat exchanger is 922 K (1200° F), only limited data could be taken at 838 K (1050° F) due to the temperature drop from the water addition.

The combustor was operated at a constant fuel - dry-air ratio to give a desired exit temperature of 1478 K (2200° F) with dry air. At the 506 K (450° F) inlet air temperature condition, however, the fuel flow required for an exit temperature of 1478 K (2200° F) could not be supplied and an exit temperature of 1366 K (2000° F) was run instead.

Combustor inlet air temperature, which is expressed in degrees kelvin (°R), is normalized to 288 K (518.68° R) for correlating purposes. This normalized temperature ratio θ is commonly used to correlate engine test data.

RESULTS AND DISCUSSION

Tests to determine exhaust emissions and combustion efficiency were conducted on three different days. Two water spray nozzles with different flow ranges were used to

vary the combustor inlet humidity. The overlap in flow ranges allowed for a check on the water vaporizing and gas sampling techniques. Repeatability of the data over the testing period was excellent.

NO_x Emission

Effect of inlet-air humidity. - The effect of inlet-air humidity on the formation of NO_x is shown in figure 9, plotted on semi-log coordinates. The data were taken at a constant pressure of 6 atmospheres and a reference Mach number of 0.065. The slope of the NO_x against humidity curves is essentially the same over the range of inlet-air temperature tested from 506 to 838 K (450° to 1050° F). At a constant inlet-air temperature, the emission index decreases with increasing humidity H at a constant exponential rate:

$$\text{NO}_x \sim e^{-19H} \quad (1)$$

where H is expressed as grams of water per grams dry air. In order to determine the NO_x emission index at zero humidity, equation (1) may be written as

$$\text{NO}_{x_0} = \text{NO}_x e^{19H} \quad (2)$$

where the subscript 0 indicates the NO_x value at zero humidity. This equation correlates the NO_x emission index data with humidity better than the previously mentioned linear estimate, especially over a wide range of humidity. A graph of equation (2) is shown in figure 10. Included in the figure are the correlating functions based on a linear reduction in NO_x of 25 percent per percent (Moore, ref. 1) and 20 percent per percent (Lipfert, ref. 2) humidity.

The problem with a linear reduction in NO_x is the implicit statement that at some point a 100-percent reduction is accomplished or that there is no NO_x left. At a nitric oxide reduction rate of 25 percent per percent of humidity one would expect zero NO_x with 4 percent humidity. If an engine exhaust were measured for pollutants under these circumstances, the factor to determine its emission index at zero humidity would be infinite.

The semi-log plot of figure 10 shows that at low values of humidity all of the correlating functions approach 1 at nearly the same slope. The factor that would be applied by using the linear rates is always higher than the one using the exponential rate equation. The curves illustrate how the linear rates diverge from the exponential and approach an infinite slope.

The experimental data indicate that the NO_x emission index is reduced exponentially with an increase in inlet-air humidity. A theoretical treatment of this subject is presented in the appendix. This treatment is similar to that of Moore's (ref. 1) but is based on a pressure of 6 atmospheres, a range of inlet-air temperatures, and ASTM Jet-A fuel. The theoretical results substantiate the exponential decrease in the NO_x emission index with increasing humidity. The theoretical results predict an effect due to inlet-air temperature; but the experimental data indicate that such an effect is minimal as a practical consideration.

Effect of inlet-air humidity on nitric oxide (NO). - The instrument used to measure the oxides of nitrogen also allows measurement of the quantity of nitric oxide (NO). Figure 11 shows the percent of the NO_x emission index which was found to be NO for this combustor. At near zero humidity, NO made up approximately 91 percent of NO_x emission index at all inlet-air temperatures. At the 755 K (900° F) inlet-air temperature, a variation in the inlet humidity had no effect on the percentage of NO in the NO_x emission index. At lower inlet-air temperatures a decrease in the percentage of NO is observed with an increase in humidity. Although slight, this variation in NO percent of NO_x with humidity may be of interest to those who study analytical combustor models.

Effect of inlet-air temperature on NO_x . - The effect of inlet-air temperature on NO_x emission index is shown in figure 12 for this combustor. The NO_x values were taken from the zero humidity intercepts in figure 9. The results obtained from this procedure correlate when plotted semilogarithmically and show that increasing inlet-air temperature increases the NO_x emissions exponentially. This relation may be expressed as

$$\text{NO}_x \sim e^{1.14 \theta} \quad (3)$$

where θ is the inlet-air temperature normalized to the standard absolute temperature at sea level, 288 K (518.68° R). At constant combustor pressure, reference Mach number, and humidity, the NO_x emission indices at two inlet temperature conditions are related:

$$\frac{\text{NO}_{x_2}}{\text{NO}_{x_1}} = e^{1.14(\theta_2 - \theta_1)} \quad (4)$$

where the subscripts 1 and 2 designate the emission index and inlet-air temperature at the respective conditions.

It is not known at this time whether the rate of change of the NO_x emission index with inlet-air temperature is unique to each combustor configuration or can be generalized to all combustors. Much of the early data reported from sampling combustors

in the field presented NO_x as a function of engine speed or maximum power setting. Since combustor inlet temperature and pressure vary with engine speed, it has been difficult to determine the appropriate correlating parameters for NO_x . Lipfert (ref. 2) correlates NO_x from engine data as a function of combustor inlet temperature only and does not try to separate the pressure effect. The following sections discuss the effect of reference Mach number and pressure on NO_x formation in this combustor.

Effect of reference Mach number on NO_x . - The production of oxides of nitrogen in combustion flames is thought to be directly related to the time the species are subjected to high temperature. This time is directly related to the primary (hot) zone length and inversely with the average through-put velocity. For fixed geometry, constant pressure, and constant inlet and exit temperature (constant fuel-air ratio), the hot zone length is a constant. The average through-put velocity can then be expressed as the reference Mach number. (The reference Mach number is based on the maximum cross-sectional area, the mass flow rate, pressure, and inlet-air temperature.) The NO_x formation should thus vary inversely with reference Mach number.

Figure 13 shows the effect of inlet-air humidity on the NO_x emission index for a reference Mach number of 0.073. Data at a reference Mach number of 0.065 (from fig. 9) are also included. The NO_x emission index values at zero humidity taken from figure 13 are plotted against reference Mach number in figure 14 on log-log coordinates. Also shown for comparison are the data taken from reference 8 for two advanced annular combustors which were operated over a larger range of reference Mach numbers. For constant inlet and exit temperature, the NO_x emission index varies with reference Mach number to the -1 power:

$$\frac{\text{NO}_{x_2}}{\text{NO}_{x_1}} = \frac{M_1}{M_2} \quad \text{or} \quad \text{NO}_{x_i} M_i = \text{constant} \quad (5)$$

Variation in combustor fuel-air ratio would be expected to change the hot zone length and temperature. The first-order effects of variations in fuel-air ratio are removed by using the emission index (dividing the ppm values by the fuel-air ratio).

Effect of pressure on NO_x . - The effect of inlet-air humidity on NO_x emission index for a pressure of 4 atmospheres, reference Mach number of 0.080, and inlet temperature of 838 K (1050° F) is shown in figure 15. Only limited data were taken at this point, and the best fit of the humidity correction $e^{-19 \cdot H}$ was used on the data to obtain the NO_x emission index at zero humidity. This zero humidity intercept and the intercept from figure 9 which is at a reference Mach number of 0.065 are correlated to a common reference Mach number as discussed in the previous section (by multiplying the Mach number by the emission index). The product (Mach number times emission index) is plotted

against inlet total pressure in figure 16. This log-log plot shows that for the limited range of pressures investigated here NO_x formation varies with pressure to the 0.5 power. This is in agreement with Fenimore (ref. 9), who suggests that the effect of pressure is to the 0.5 ± 0.1 power, and with the Sawyer (ref. 10), who has correlated NO_x data from a variety of engines with varying pressure ratios:

$$\frac{\text{NO}_{x_2}}{\text{NO}_{x_1}} \sim \left(\frac{P_2}{P_1} \right)^{0.5} \quad (6)$$

NO_x Correlating Parameter

The NO_x data from this study can be correlated with inlet-air humidity, temperature, pressure, and reference Mach number. The correlating parameter for any two points inside the realm of the test data would be

$$\frac{\text{NO}_{x_2}}{\text{NO}_{x_1}} = e^{-19(H_2 - H_1)} e^{1.14(\theta_2 - \theta_1)} \frac{M_1}{M_2} \left(\frac{P_2}{P_1} \right)^{0.5} \quad (7)$$

A standard NO_x number for this combustor may be calculated by substituting the measured quantities for one set of variables and the standard quantities for the other set of variables in equation (7). For example, if we substitute the number 1 subscripted variables with the measured quantities and substitute the number 2 subscripted variables with the standard quantities,

$$\left. \begin{aligned} P_{\text{STD}} &= 1 \\ \theta_{\text{STD}} &= 1 \\ H_{\text{STD}} &= 0 \\ M_{\text{STD}} &= 0.1 \end{aligned} \right\} \quad (8)$$

then

$$\text{NO}_{x_{\text{STD}}} = 10 \text{NO}_{x_1} e^{19H_1} e^{-1.14(\theta_1 - 1)} M_1 P_1^{-0.5} \quad (9)$$

The standard conditions listed above for pressure and temperature are the current standard correlating parameters used in the aircraft industry. As yet, no standard values for humidity and reference Mach number have yet been established. Those listed in equation (8) are the author's suggested standards for these parameters.

$NO_{x_{STD}}$ implies that the NO_x emission index for this combustor would be the $NO_{x_{STD}}$ number if the combustor were operated at the standard conditions (eq. (8)).

$NO_{x_{STD}}$ numbers were calculated for the combustor used in these tests for all the data points and are shown in figure 17. The figure shows that the $NO_{x_{STD}}$ number for this combustor is approximately 0.64 ± 0.03 . The data correlates well to this number with the exception of the data taken at 506 K (450° F) which appears to give a slightly lower number. This may be due to the fact that the average exit temperature for the data taken at this condition was only 1366 K (2000° F) rather than 1478 K (2200° F). This suggests that an additional factor to include the effect of the combustor exit temperature be added to the basic correlating parameter:

$$\frac{NO_{x_2}}{NO_{x_1}} = e^{-19(H_2-H_1)} e^{1.14(\theta_2-\theta_1)} \frac{M_1}{M_2} \left(\frac{P_2}{P_1}\right)^{0.5} \alpha \quad (10)$$

where α is as yet an unknown function of the exit temperature.

The $NO_{x_{STD}}$ number may be used to predict the emission index at any condition in the realm of the data:

$$NO_x(H, \theta, M, P) = NO_{x_{STD}} (0.1) e^{-19H} e^{1.14(\theta-1)} M^{-1} P^{0.5} \alpha \quad (11)$$

Combustion Efficiency

Combustion efficiency as determined by gas sampling varied only slightly from 100 percent over all the conditions tested. The lowest efficiency measured by gas sampling was at the lowest inlet-air temperature tested (506 K (450° F)) and the highest humidity (0.042). Combustion efficiency at this condition was 99.73 percent. Thermocouple measurements with the rotating probes had data scatter larger than any perceivable variation in combustion efficiency from 100 percent.

The efficiency data indicate that the combustion process was not seriously impaired by the increase in humidity. The NO_x emissions results are therefore applicable to any combustor whose efficiency is close to 100 percent.

Carbon monoxide. - Combustion inefficiency as calculated from gas sampling data was primarily due to the amount of unburned carbon monoxide. Figure 18 shows the effect of humidity on the emission index of carbon monoxide from this combustor. At inlet-air temperatures equal to or greater than 589 K (600^o F), variations in humidity had no effect on the level of carbon monoxide in the exhaust. The level of the emission index decreases with increasing inlet-air temperature as expected. At the 506 K (450^o F) inlet-air temperature condition, an increase in carbon monoxide is observed at humidity values greater than 0.02.

The increase in carbon monoxide is not large for this combustor but may indicate a carbon monoxide emissions problem area for low pressure ratio engines which have low combustor inlet-air temperatures. The effect of inlet-air humidity on these combustors at idle conditions may be substantial.

Unburned hydrocarbons. - Gas sampling measurements showed negligible amounts of unburned hydrocarbons. The emission index for unburned hydrocarbons was less than 0.01 (0.001 percent inefficiency) except at the 506 K (450^o F) inlet-air temperature condition. Figure 19 shows the effect of humidity of unburned hydrocarbons at this condition. The increase in unburned hydrocarbon is coincident with the increase in carbon monoxide at a humidity of 0.02 for this combustor. Although the level of unburned hydrocarbons is not high, the trend again indicates a potential hydrocarbon and carbon monoxide emissions problem for low pressure ratio engines on high humidity days, especially at idle conditions.

Sample Validity

A comparison of gas sampling to metered fuel-air ratios for all the data is shown in figure 20. Most of the data exhibit a scatter of ± 5 percent about the mean value. The fact that the mean value is 7.5 percent high is probably symptomatic of the location of the two fixed sampling probes.

Smoke

Smoke data taken at a pressure of 6 atmospheres and over a range of inlet-air temperature and humidity conditions is shown in figure 21. The smoke numbers are below the visible limit, and variations in inlet-air humidity and temperature produced no significant effect on smoke at this pressure. Since smoke formation has been found to be highly dependent on pressure, tests at a higher pressure may show that variations in inlet humidity will effect the smoke formation.

SUMMARY OF RESULTS AND RECOMMENDATIONS

Tests were conducted to determine the effect of inlet-air humidity on the formation of oxides of nitrogen from a gas turbine type combustor. Combustor inlet-air temperature ranged from 506 K (450⁰ F) to 838 K (1050⁰ F). Tests were run primarily at a constant pressure of 6 atmospheres and a reference Mach number of 0.065. Additional data were taken to determine the effect of pressure and reference Mach number. The following results were obtained:

1. The NO_x emission index decreased exponentially with increasing inlet-air humidity: $NO_x \sim e^{-19H}$, where H is the mass ratio of water to dry air. It is recommended that future NO_x emissions data be corrected to zero humidity by multiplying the recorded value by e^{19H} .

2. The NO_x emission index increased exponentially with increasing normalized inlet-air temperature. At constant pressure and reference Mach number, the NO_x varied as $e^{1.14\theta}$. It is unknown at this time whether the exponent (1.14) on θ is independent of combustor design or may be used as a yardstick in screening future combustor designs. Additional test data are needed in this area.

3. At constant inlet and exit temperatures and constant pressure, the NO_x emission index varied inversely with reference Mach number.

4. At constant inlet and exit temperature, the NO_x emission index was found to vary directly with pressure to the 0.5 power.

5. A NO_x correlating parameter was proposed to correlate the data to a standard number. The NO_x emission index at any condition can then be found as a function of humidity, temperature, reference Mach number, and pressure. The standard NO_x number for the test combustor was 0.64.

6. Nitric oxide made up 91 percent of the oxides of nitrogen emission index at near zero humidity. At a 755 K (900⁰ F) inlet-air temperature, variation in inlet humidity had no effect on the percentage of NO in NO_x emission index. At lower inlet-air temperatures a slight decrease in the percentage of NO was observed with increasing humidity.

7. Combustion efficiency as measured by gas sampling was close to 100 percent at all test conditions. A slight deviation from 100 percent was noted at the lowest inlet-air temperature tested (506 K (450⁰ F)), which indicates a potential carbon monoxide and hydrocarbon emissions problem area for low pressure ratio engines on high humidity days, especially at idle conditions.

8. Smoke numbers were below the visible limit and variations in inlet humidity and temperature produced no significant effect on smoke at the test pressure of 6 atmospheres. Additional tests at higher pressures may show some effect of humidity on smoke.

Lewis Research Center,
National Aeronautics and Space Administration,
Cleveland, Ohio, June 12, 1973,
501-24.

APPENDIX - THEORETICAL CONSIDERATIONS

The combustion of fuel with air results in flame temperatures sufficient to cause oxygen and nitrogen to react and form nitric oxide (NO). The humidity affects the formation of NO because it reduces the flame temperature upon which the NO formation is strongly dependent. The treatment presented here is similar to Moore's (ref. 1), but this one is based on a pressure of 6 atmospheres, a range of inlet-air temperatures, and ASTM Jet-A fuel.

Recent studies of NO formation (refs. 9 to 12) indicate that the reaction scheme first proposed by Zeldovich is dominant:



For conditions of fuel-rich combustion the following may also be of consequence:



This system of equations may be solved for the rate formation of NO by the so called "equilibrium kinetics" approach. The rate of formation of NO is slow compared to the combustion reactions which are assumed complete. If we further assume that the combustion species except NO are in chemical equilibrium at the adiabatic flame temperature and that a steady concentration of N atoms has been achieved, then from equations (A1) and (A2) we find

$$\frac{d[\text{NO}]}{dt} = \frac{2k_1[\text{O}][\text{N}_2] \frac{1 - k_2k_4[\text{NO}]^2}{k_1k_3[\text{O}_2][\text{N}_2]}}{1 + \frac{k_2[\text{NO}]}{k_3[\text{O}_2]}} \quad (\text{A4})$$

When solving for the initial rate of formation equation (A4) simplifies to

$$\frac{d[\text{NO}]}{dt} = 2k_1[\text{O}][\text{N}_2] = 2k_2K_1[\text{O}][\text{N}_2] \quad (\text{A5})$$

where K_1 is the equilibrium constant k_1/k_2 .

As shown by Fenimore (ref. 9), the inclusion of reaction (A3) does not alter the expression for the initial rate of NO formation. Using the same values for equilibrium constant and reaction rate constant as given by Fenimore we arrive at

$$\frac{d[\text{NO}]}{dt} = 9.5 k_2 \exp\left[-75.5 \frac{\text{kcal}}{RT}\right] [\text{O}][\text{N}_2] \quad (\text{A6})$$

with

$$k_2 = 13 \pm 4 \times 10^{12} \text{ cm}^3 \text{ mole}^{-1} \text{ sec}^{-1}$$

This result shows nitric oxide concentration to be strongly temperature dependent as well as being dependent on oxygen atom concentration.

For many fuels and combustion systems the previous approach gives surprisingly good results. However, Fenimore observed that in premixed hydrocarbon flames an amount of NO had been rapidly formed in the primary reaction zone. Using equation (A6) with equilibrium oxygen atom concentrations gave a rate of production that was too low; Fenimore therefore referred to this initially formed NO as "prompt NO." Whether the formation of this NO is due to attack of nitrogen by carbon or hydrocarbon molecules, by a super-equilibrium concentration of oxygen atoms, or some other means has not been resolved.

The effect of water vapor on adiabatic flame temperature at stoichiometric fuel-air ratio is shown in figure 22. The adiabatic flame temperature and equilibrium concentrations for ASTM Jet-A fuel were evaluated with the computer program of reference 13. For the range of experimental test conditions the calculations show about a 20 K drop in flame temperature for each 1 percent of water vapor. This is in agreement with Moore for hydrogen-air and ethylene-air at 1 atmosphere and 300 K inlet temperature.

The nitric oxide production rate was computed using equation (A6) and the equilibrium data. The results are shown in figure 23 for varying inlet temperature. Also shown for comparison is Moore's data. At the higher inlet temperatures the production rate is so large that at any reasonable residence time large concentrations would result. However, this simplified approach does not include flow field or mixing phenomena, and in a practical system residence time at the adiabatic flame temperature may be a small fraction of the total residence time. As can be seen from the figure the exponential slope of the curves varies with inlet temperature. This slope can be used to determine a zero humidity correlating factor as explained earlier. The correlating factor is shown in figure 24 along with the experimental data which show a lower required correction. It was not possible to separate an inlet temperature effect from the experimental data.

REFERENCES

1. Moore, John: The Effects of Atmospheric Moisture on Nitric Oxide Production. *Combustion & Flame*, vol. 17, no. 2, Oct. 1971, pp. 265-267.
2. Lipfert, F. W.: Correlation of Gas Turbine Emissions Data. Paper 72-GT-60, ASME, Mar. 1972.
3. Adam, Paul W.; and Norris, James W.: Advanced Jet Engine Combustor Test Facility. NASA TN D-6030, 1970.
4. Rusnak, J. P.; and Shadowen, J. H.: Development of an Advanced Annular Combustor. Rep. PWA-FR-2832, Pratt & Whitney Aircraft (NASA CR-72453), May 30, 1969.
5. Anon.: Procedure for the Continuous Sampling and Measurement of Gaseous Emissions from Aircraft Turbine Engines. Aerospace Recommended Practice 1256, SAE, 1971.
6. Anon.: Aircraft Gas Turbine Engine Exhaust Smoke Measurement. Aerospace Recommended Practice 1179, SAE, 1970.
7. Ellenwood, Frank O.; and Mackey, Charles O.: Thermodynamic Charts. John Wiley & Sons, Inc., 1944.
8. Jones, Robert E.; and Grobman, Jack: Design and Evaluation of Combustors for Reducing Aircraft Engine Pollution. NASA TM X-68192, 1973.
9. Fenimore, C. P.: Formation of Nitric Oxide in Premixed Hydrocarbon Flames. Thirteenth Symposium (International) on Combustion. Combustion Inst., 1971, pp. 373-379.
10. Sawyer, R. F.; Cernansky, N. P.; and Oppenheim, A. K.: Factors Controlling Pollutant Emissions from Gas Turbine Engines. Presented to Propulsion and Energetics Panel of AGARD, London, England, Apr. 9-13, 1973.
11. Tuteja, A. D.; and Newhall, H. K.: Nitric Oxide Formation in Laminar Diffusion Flames. Emissions from Continuous Combustion Systems. W. Cornelius and W. G. Agnew, eds., Plenum Press, 1972, pp. 109-121.
12. Bowman, C. T.; and Seery, D. J.: An Investigation of NO Formation Kinetics in Combustion Processes: The Methane-Oxygen-Nitrogen Reaction. Emissions from Continuous Combustion Systems. W. Cornelius and W. G. Agnew, eds., Plenum Press, 1972, pp. 123-139.
13. Gordon, Sanford; and McBride, Bonnie J.: Computer Program for Calculation of Complex Chemical Equilibrium Compositions, Rocket Performance, Incident and Reflected Shocks, and Chapman-Jouguet Detonations. NASA SP-273, 1971.

TABLE I. - NOMINAL OPERATING CONDITIONS

Condition	Pressure, atm	Combustor reference Mach number	Inlet-air temperature		Ratio of inlet-air temperature to 288 K (518.68° F), θ	Fuel-air ratio	Exit temperature	
			K	°F			K	°F
1	6	0.065	506	450	1.75	0.0247	1366	2000
2	↓	↓	589	600	2.04	.0257	1478	2200
3			672	750	2.33	.0234	↓	↓
4			755	900	2.62	.0211	↓	↓
5			838	1050	2.91	.0185	↓	↓
6	↓	.073	755	900	2.62	.0211	↓	↓
7		.080	838	1050	2.91	.0185	↓	↓

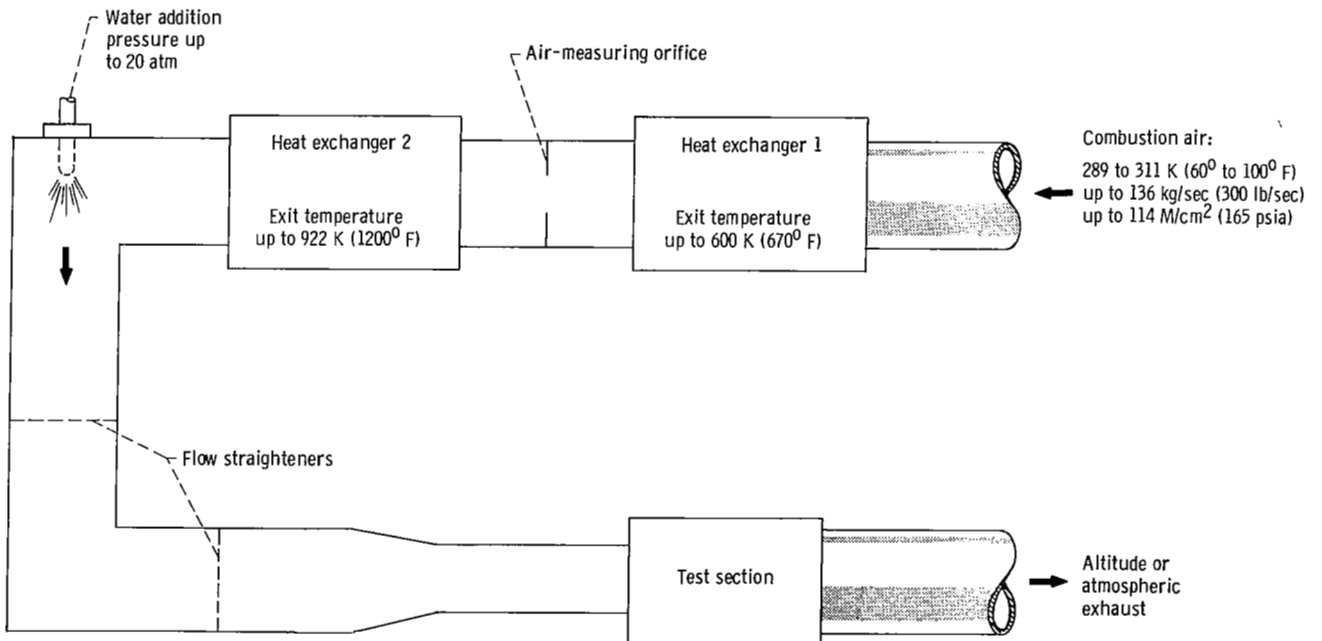

Figure 1. - Schematic of test facility.

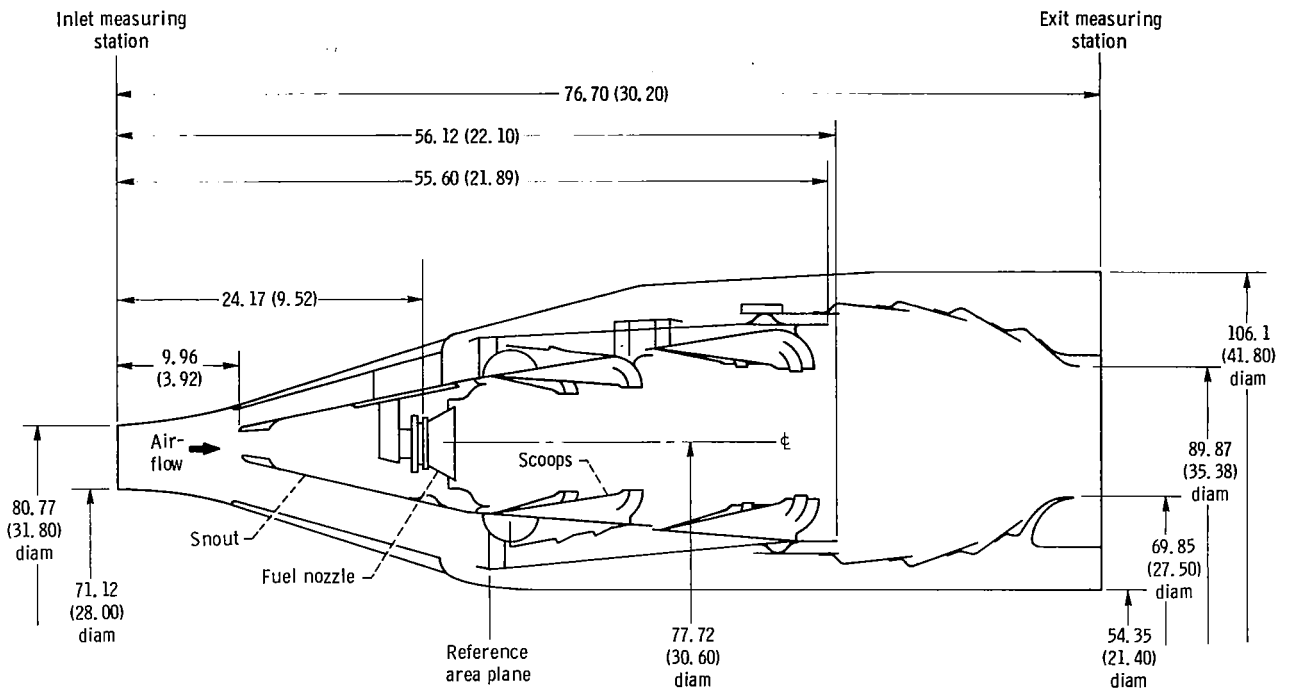
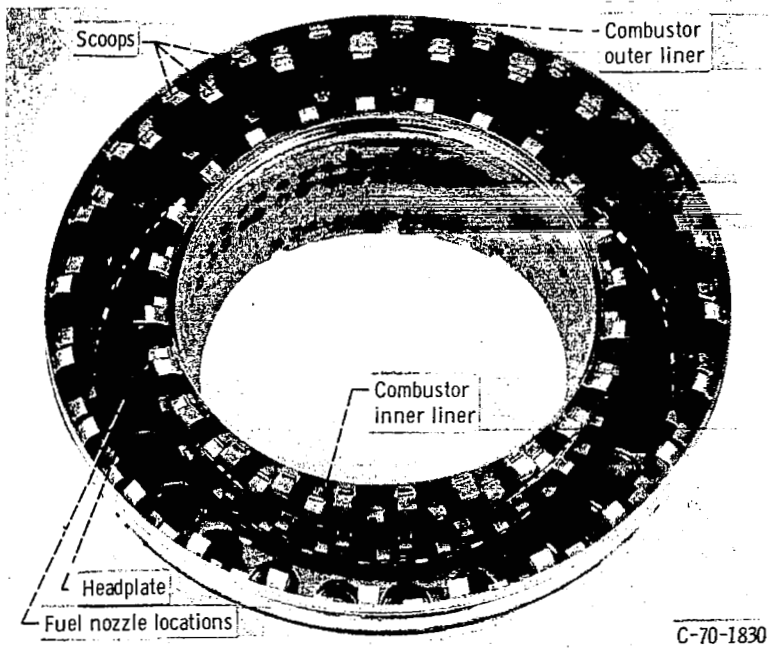
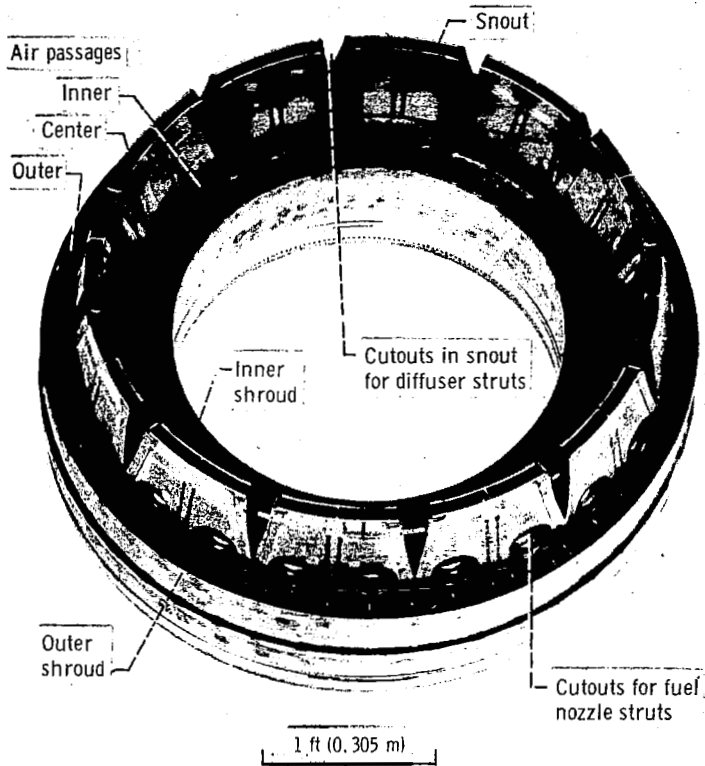

Figure 2. - Cross section of combustor. Dimensions are in cm (in.).

CD-11423-28



(a) View from downstream end.



(b) View from upstream end.

Figure 3. - Annular ram-induction combustor.

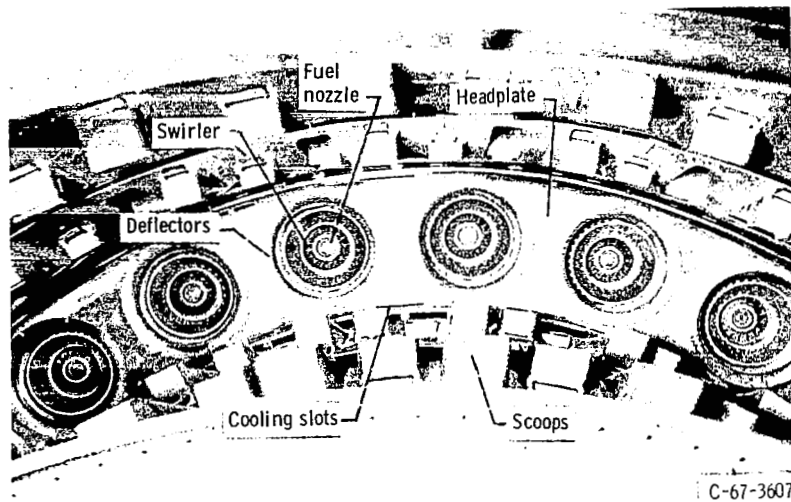

(c) Closeup view from downstream end.

Figure 3. - Concluded.

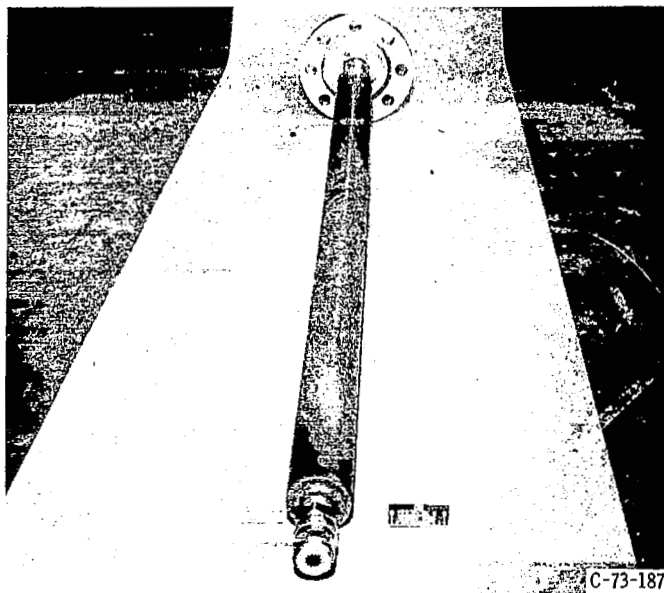

Figure 4. - Nozzle for water addition, high range.

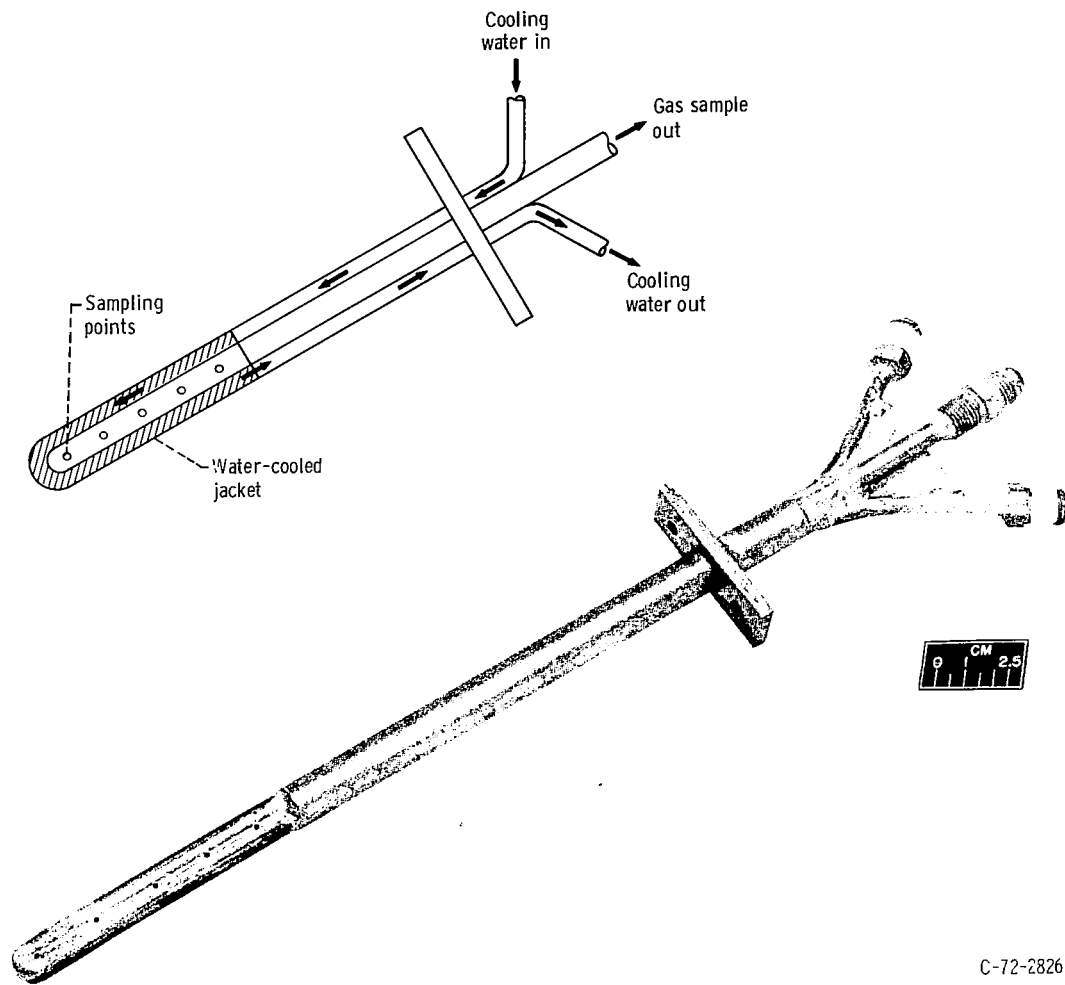

Figure 5. - Gas sampling probe.

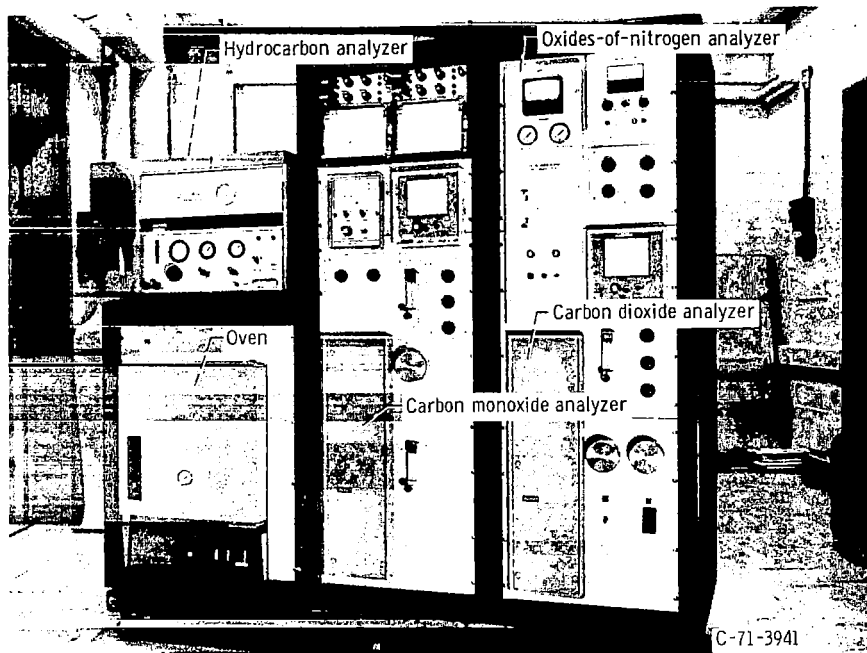

Figure 6. - Gas sampling instrument console.

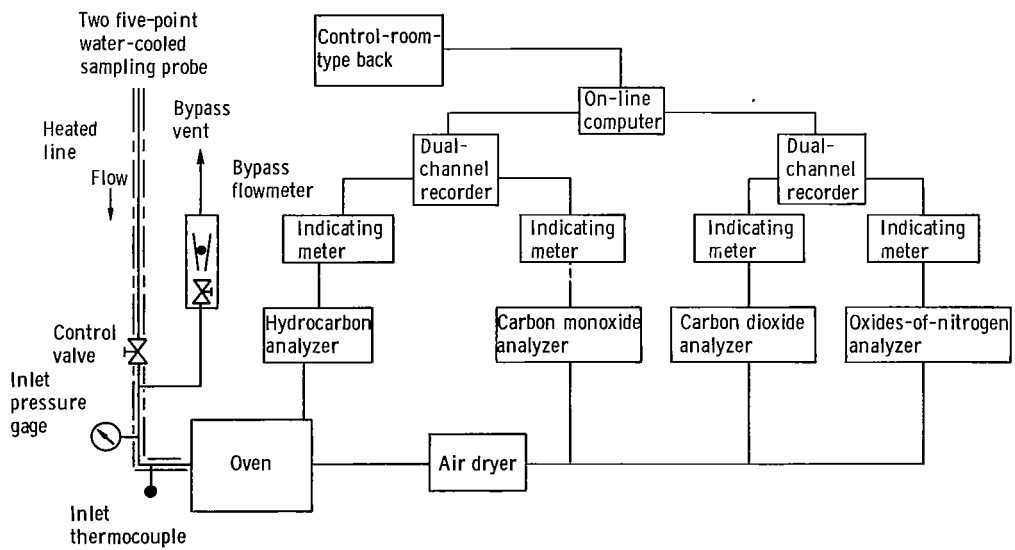

Figure 7. - Schematic diagram of gas analysis system.

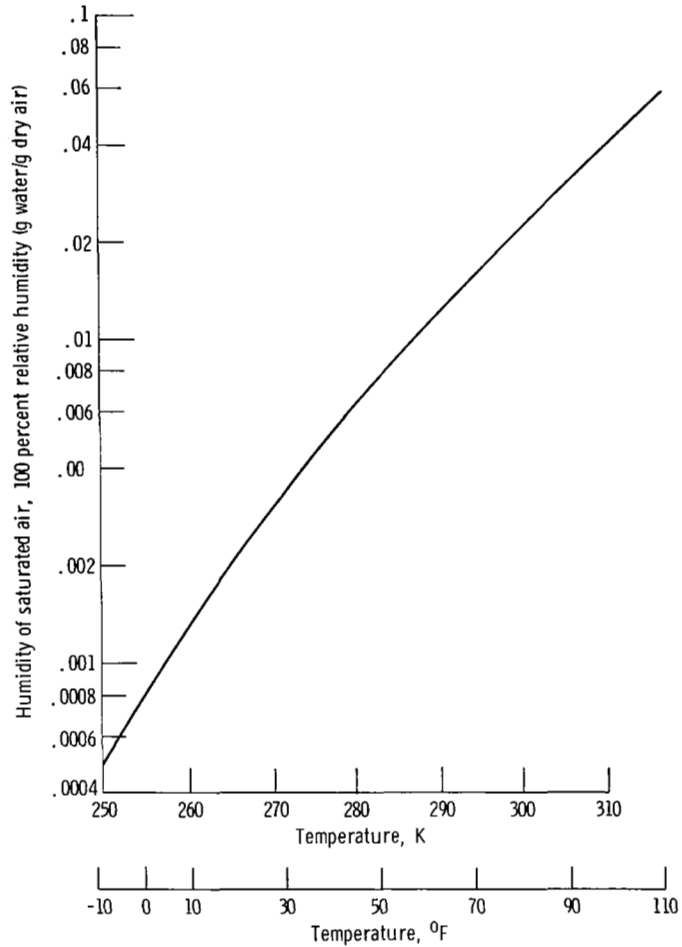

Figure 8. - Humidity of saturated air as function of ambient temperature.

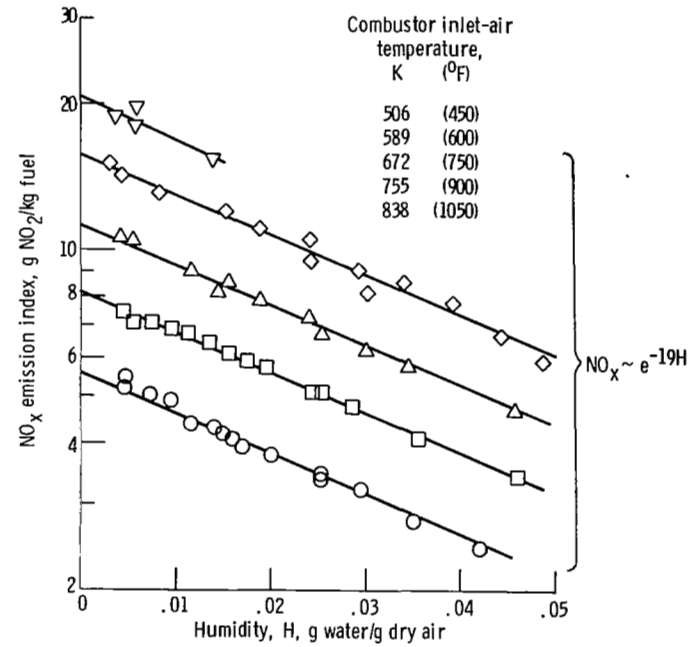

Figure 9. - Effect of inlet-air humidity on formation of oxides of nitrogen. Combustor pressure, 6 atmospheres; reference Mach number, 0.065; nominal exit temperature, 1478 K (2200° F).

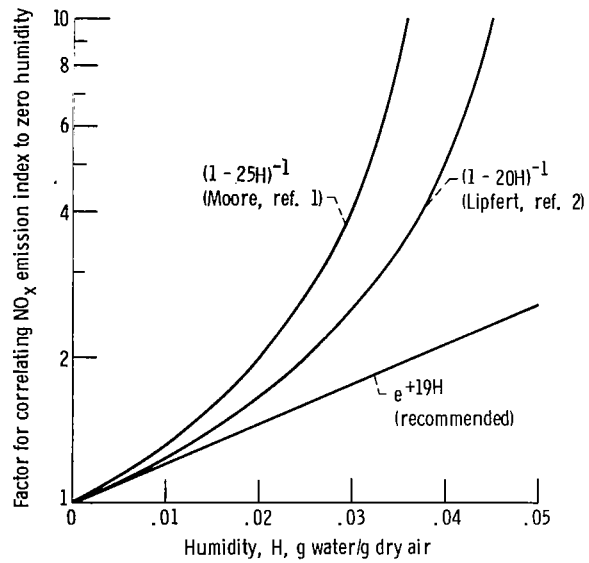

Figure 10. - Correlating factors for NO_x emission index as function of inlet-air humidity, correlating to zero humidity.

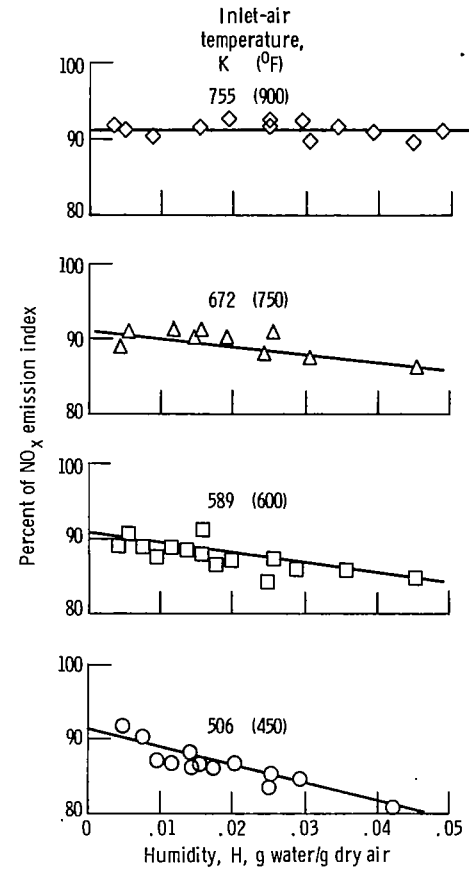

Figure 11. - Effect of inlet-air humidity on percent of NO_x emission index which is nitric oxide (NO). Combustor pressure, 6 atmospheres; reference Mach number, 0.065; nominal exit temperature, 1478 K ($2200^{\circ}F$).

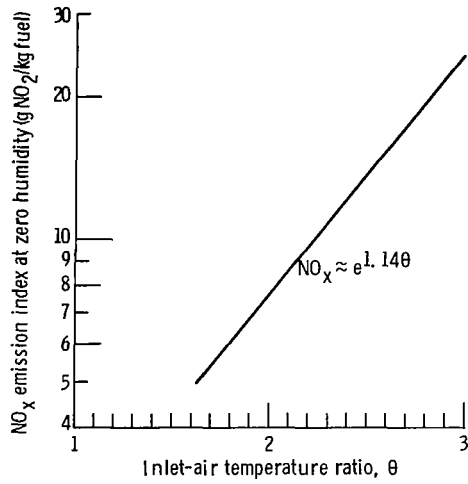

Figure 12. - Emission index of oxides of nitrogen as function of normalized inlet-air temperature ratio. Humidity, 0 percent; nominal reference Mach number, 0.065; nominal exit temperature, 1478 K (2200° F); total inlet-air pressure, 6 atmospheres.

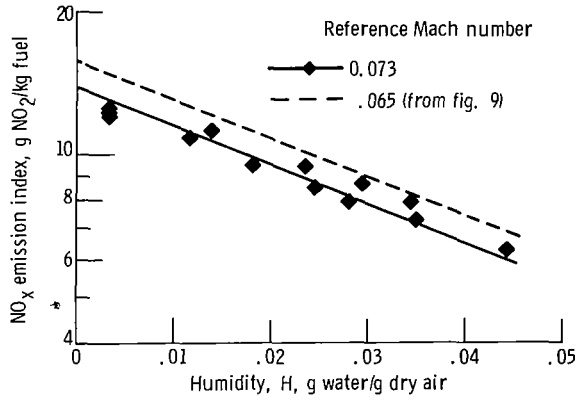

Figure 13. - Effect of inlet-air humidity on oxides of nitrogen formation for reference Mach numbers of 0.073 and 0.065. Inlet temperature, 755 K (900° F); combustor pressure, 6 atmospheres; nominal exit temperature, 1478 K (2200° F).

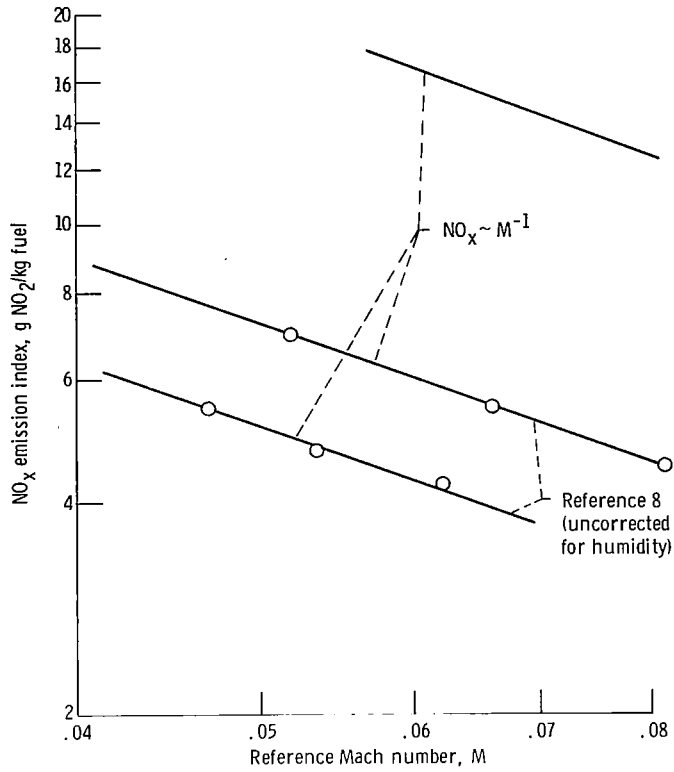

Figure 14. - Effects of reference Mach number on formation of oxides of nitrogen. Total inlet temperature ratio, θ , 2.62; total inlet pressure, 6 atmospheres; nominal exit temperature, 1478 K (2200° F); inlet-air humidity, 0.

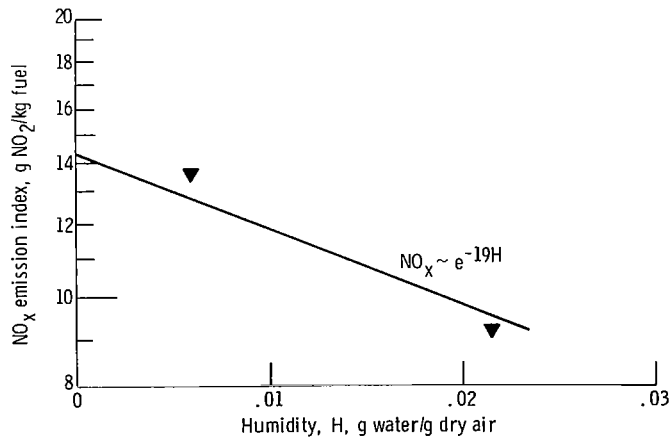

Figure 15. - Effect of inlet-air humidity on oxides of nitrogen formation for inlet-air temperature ratio of 2.91. Combustor pressure, 4 atmospheres; reference Mach number, 0.080; nominal exit temperature, 1478 K (2200° F).

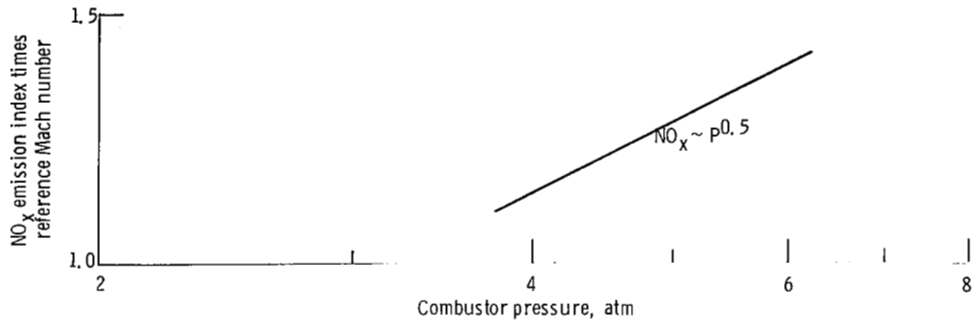

Figure 16. - Effects of combustor pressure on formation of oxides of nitrogen at constant inlet temperature ratio of $\theta = 2.91$. Nominal exit temperature, 1478 K (2200° F); humidity, 0.

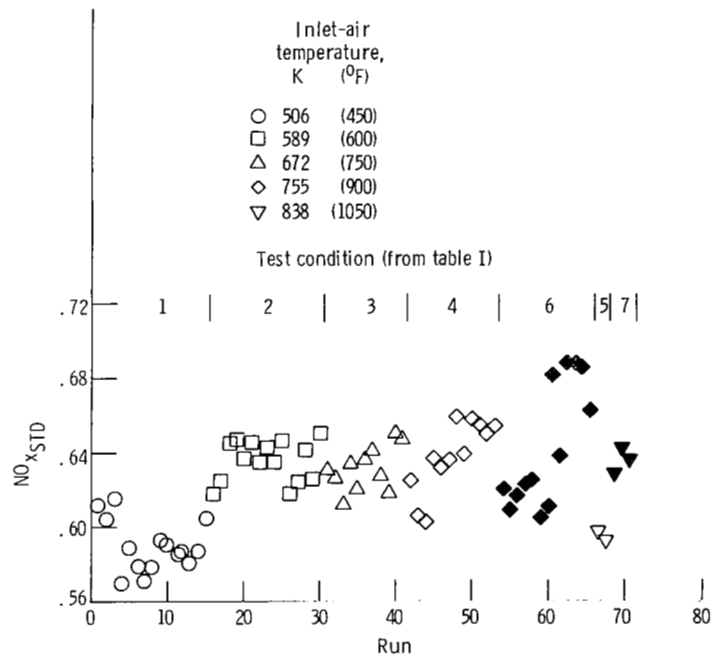

Figure 17. - Standard NO_x number determined by correlating parameter:
 $NO_{xSTD} = 10NO_{xi} e^{19H_i} e^{-1.14(\theta-1)} M_i P_i^{-0.5}$. Solid data points correspond to data taken at pressures and reference Mach numbers different from 6 atmospheres and 0.065, respectively (see table I).

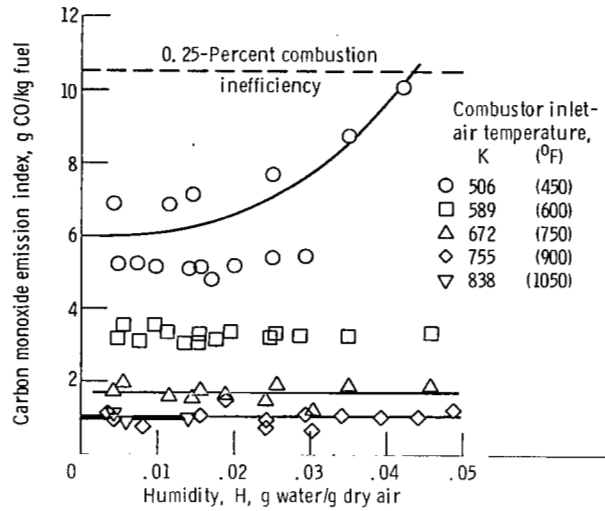

Figure 18. - Effect of inlet-air humidity on carbon monoxide emissions. Combustor pressure, 6 atmospheres; reference Mach number, 0.065; nominal exit temperature, 1478 K (2200° F).

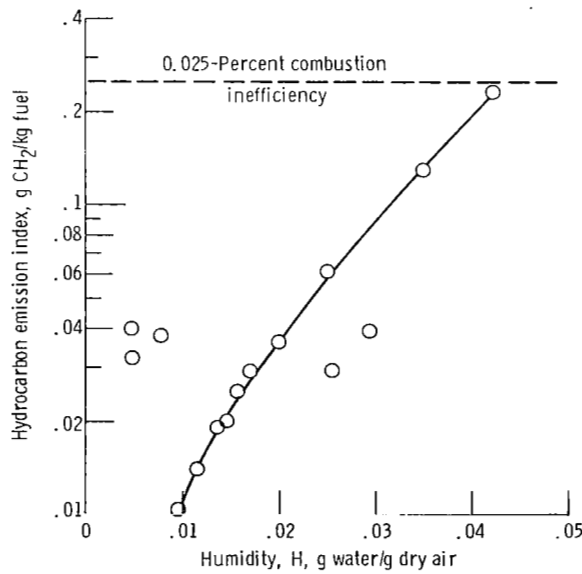

Figure 19. - Effect of inlet-air humidity on unburned hydrocarbon emissions. Combustor pressure, 6 atmospheres; reference Mach number, 0.065; inlet-air temperature, 506 K (450° F); nominal exit temperature, 1366 K (2000° F).

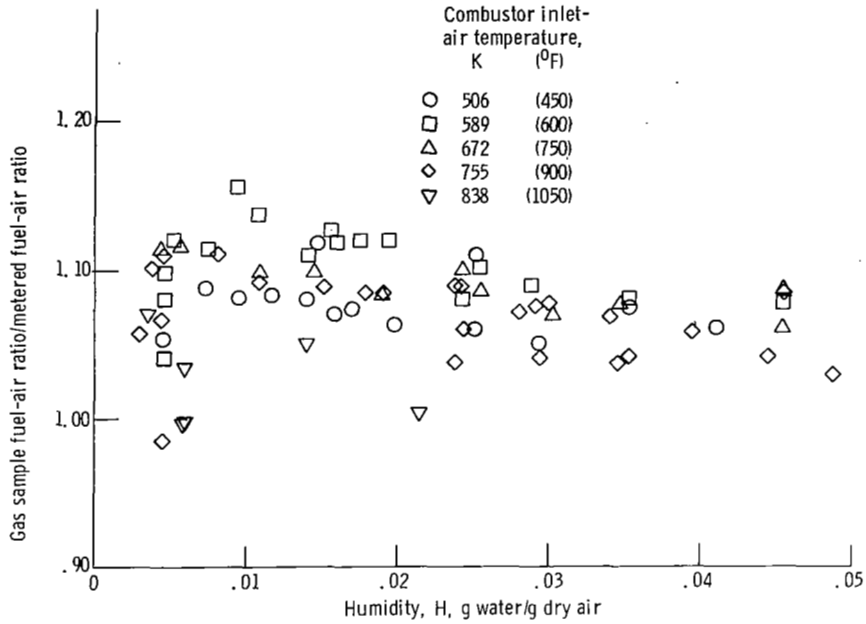

Figure 20. - Ratio of fuel-air ratios as function of inlet-air humidity.

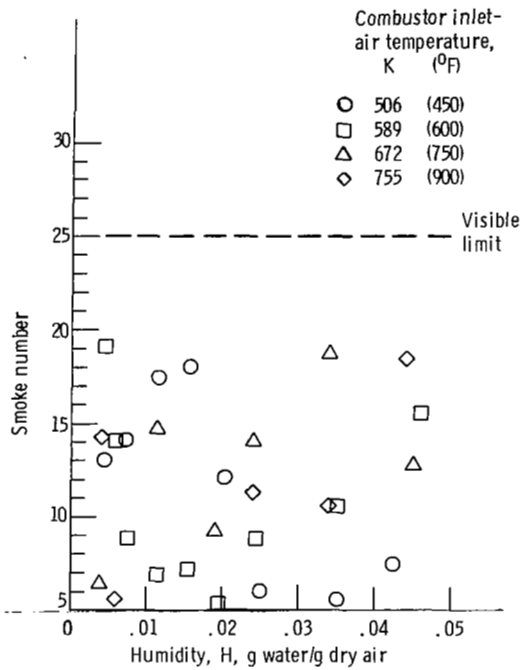

Figure 21. - Smoke number versus inlet air humidity at various inlet air temperatures. Combustor pressure 6 atmospheres; reference Mach number, 0.065; nominal exit temperature, 1478 K (2200^oF).

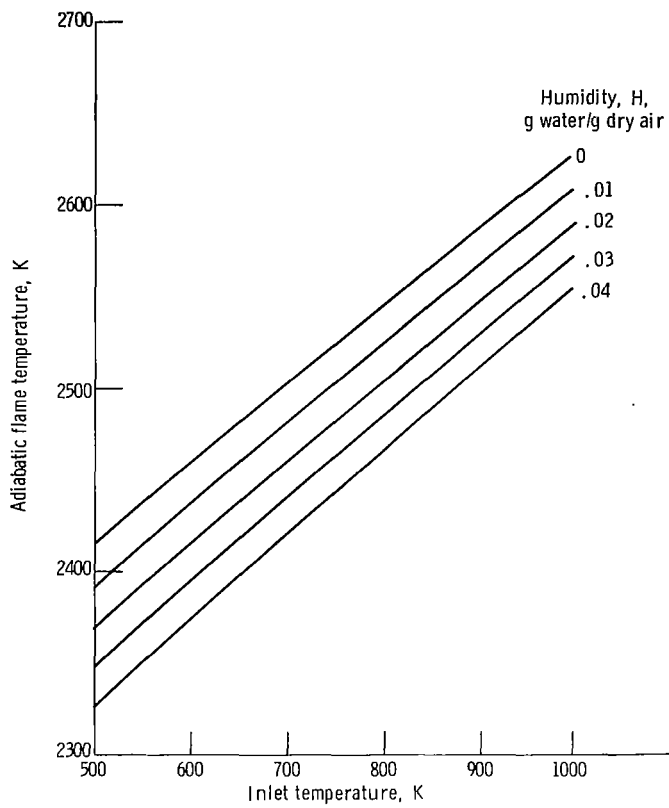

Figure 22. - Effect of inlet-air temperature and humidity on adiabatic flame temperature. Pressure, 6 atmospheres; Equivalence ratio, ϕ , 1.0; fuel, ASTM Jet-A.

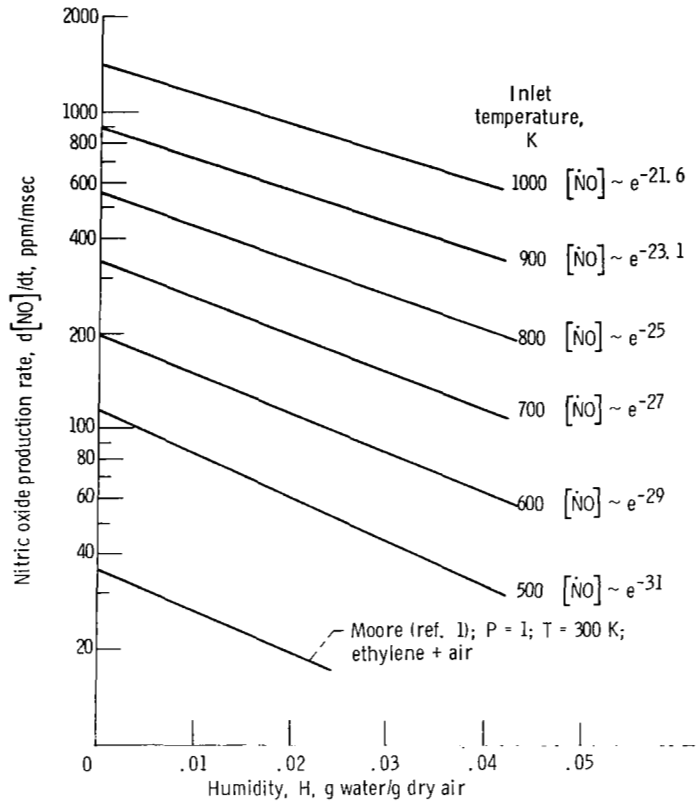

Figure 23. - Effect of inlet-air humidity and temperature on nitric oxide production rate. Pressure, 6 atmospheres; Equivalence ratio, ϕ , 1.0; fuel, ASTM Jet-A.

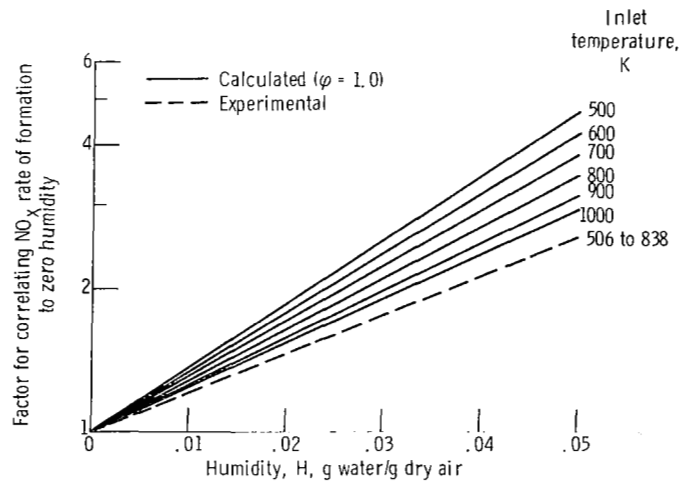

Figure 24. - Predicted and experimental correlating factors for NO_x production rate as function of inlet-air humidity and temperature. Pressure, 6 atmospheres; fuel, ASTM Jet-A fuel.

NATIONAL AERONAUTICS AND SPACE ADMINISTRATION
WASHINGTON, D.C. 20546

OFFICIAL BUSINESS
PENALTY FOR PRIVATE USE \$300

SPECIAL FOURTH-CLASS RATE
BOOK

POSTAGE AND FEES PAID
NATIONAL AERONAUTICS AND
SPACE ADMINISTRATION
451



POSTMASTER: If Undeliverable (Section 158
Postal Manual) Do Not Return

"The aeronautical and space activities of the United States shall be conducted so as to contribute . . . to the expansion of human knowledge of phenomena in the atmosphere and space. The Administration shall provide for the widest practicable and appropriate dissemination of information concerning its activities and the results thereof."

—NATIONAL AERONAUTICS AND SPACE ACT OF 1958

NASA SCIENTIFIC AND TECHNICAL PUBLICATIONS

TECHNICAL REPORTS: Scientific and technical information considered important, complete, and a lasting contribution to existing knowledge.

TECHNICAL NOTES: Information less broad in scope but nevertheless of importance as a contribution to existing knowledge.

TECHNICAL MEMORANDUMS: Information receiving limited distribution because of preliminary data, security classification, or other reasons. Also includes conference proceedings with either limited or unlimited distribution.

CONTRACTOR REPORTS: Scientific and technical information generated under a NASA contract or grant and considered an important contribution to existing knowledge.

TECHNICAL TRANSLATIONS: Information published in a foreign language considered to merit NASA distribution in English.

SPECIAL PUBLICATIONS: Information derived from or of value to NASA activities. Publications include final reports of major projects, monographs, data compilations, handbooks, sourcebooks, and special bibliographies.

TECHNOLOGY UTILIZATION PUBLICATIONS: Information on technology used by NASA that may be of particular interest in commercial and other non-aerospace applications. Publications include Tech Briefs, Technology Utilization Reports and Technology Surveys.

Details on the availability of these publications may be obtained from:

SCIENTIFIC AND TECHNICAL INFORMATION OFFICE

NATIONAL AERONAUTICS AND SPACE ADMINISTRATION

Washington, D.C. 20546