

# Effect of slip condition on couple stress fluid flow through porous medium with stenosis

Gurju Awgichew, G. Radhakrishnamacharya

**Abstract-** Steady incompressible couple stress fluid flow in a two dimensional uniform channel with stenosis has been investigated. Further, it is assumed that the channel is filled with porous material and the stenosis to be mild. The flow equations have been analytically solved using the slip condition and expressions for the resistance to flow and wall shear stress have been derived. The effects of various parameters on these flow variables have been studied. It is found that the resistance to flow as well as the wall shear stress increase with the height of stenosis. The effect of other parameters on resistance to flow and the wall shear stress have been considered.

**Index Terms:** Resistance to flow, couple stress fluid, porous medium, slip condition

## 1 INTRODUCTION

The atherosclerosis or stenosis is a well-known arterial disease. It involves deposits of fatty substances in the internal lining of an artery. The development of an obstruction in the artery can lead to serious circulatory disorders. In this situation the flow behaviour is quite different from that in a normal artery. The investigations of blood flow through arteries are of considerable importance in many cardiovascular diseases. Hence, the mathematical modeling of this type of flow can be very useful. The actual reason for formation of stenosis is not known but many researchers have studied its effect on the flow characteristics. Mates et al. [1] provided a detailed understanding of fluid mechanical behaviour of an isolated stenotic lesion in the coronary circulation. Many authors (Young [2], Zendehebudi and Moayeri [3], Radhakrishnamacharya and Srinavasa Rao [4]) studied the flow characteristics by assuming blood as Newtonian fluid. But blood shows a non-Newtonian behaviour at low shear rates in tubes of smaller diameters (Whitmore [5], Forrester and Young [6], Shukla et al. [7] and Misra and Shit [8]).

The non-Newtonian behaviour of blood is mainly due to the suspension of red blood cells in the plasma. When neutrally buoyant corpuscles are contained in a fluid and there exists a velocity gradient due to shearing stress, corpuscles have rotatory motion. Furthermore, it is observed that corpuscles have spin angular momentum, in addition to orbital angular momentum. As a result, the symmetry of stress tensor is lost in the fluid motion that is subjected to spin angular momentum. The fluid that has neutrally buoyant corpuscles, when observed macroscopically, exhibits non-Newtonian behaviour, and its constitutive equation is expressed by Stokes [9]. This represents the simplest generalization of the classical viscous

fluid theory that sustains couple stresses and the body couples. The important feature of these fluids is that the stress tensor is not symmetric and their accurate flow behaviour cannot be predicted by the classical Newtonian theory. The main effect of couple stresses will be to introduce a size dependent effect that is not present in the classical viscous theories. The importance of consideration of couple stress effects in studies of physiological and some other fluids was indicated by Cowin [10]. Studies on the couple stress fluid behaviour are very useful, because such studies bear the potential to better explain the behaviour of rheologically complex fluids, such as liquid crystals, polymeric suspensions that have long-chain molecules, lubrication as well as human/sub-human blood (Stokes [9]). Sankad and Radhakrishnamacharya [11] and Srinivasacharya and Srikanth [12] studied the flow of a couple stress fluid with different conditions.

Flows through porous medium occur in filtration of fluids and seepage of water in river beds. Movement of underground water and oils are important examples of flows through porous medium. An oil reservoir mostly contains sedimentary formation such as limestone and sandstone in which oil is entrapped. Modeling of flow problems through porous media has been of great practical significance primarily because of its potential applications in engineering, technology and industry. Porous materials are used in various engineering devices such as catalytic converters and fuel cells due to their advantages in dispersion and chemical reaction by their large contact areas. The flow of non-Newtonian fluids through a porous medium under different conditions was studied by Tong and Hu [13]. Flows through porous media may be relevant in many physiological situations such as the flow of blood in the microvessels of the lungs, which may be treated as a channel bounded by two thin porous layers ( Misra and Ghosh [14]).

In the present study, the effect of slip boundary condition

- *Corresponding Author:- G.Radhakrishnamacharya, Profesor of Mathematics, National Institute of Technology, Warangal, India. E-mail: [grk.nitw@yahoo.com](mailto:grk.nitw@yahoo.com)*
- *Gurju Awgichew, Research Scholar in anonymous Institute and Department, E-mail: [gurjua@yahoo.com](mailto:gurjua@yahoo.com)*

on an incompressible couple stress fluid flow through a two dimensional uniform channel with local stenosis and filled with porous material, is considered. Assuming that the stenosis is mild, closed-form solution has been obtained and expressions for resistance to flow and shear stress at the wall have been derived. The effects of various relevant parameters on these flow variables have been studied.

## 2 MATHEMATICAL FORMULATION

We consider steady, incompressible couple stress fluid flow through a two dimensional uniform channel with local stenosis. It is assumed that the channel is filled with porous material. Cartesian coordinate system is chosen so that the x-axis coincides with the center line of the channel and the y-axis normal to it. The stenosis is supposed to be mild and develops in a symmetric manner. The boundary of the channel is taken as (Shukla et al. [7])

$$\eta(x) = \begin{cases} d_0 - \frac{\delta}{2} \left( 1 + \cos \frac{2\pi}{L_0} \left( x - d_1 - \frac{L_0}{2} \right) \right) & ; d_1 \leq x \leq d_1 + L_0 \\ d_0 & ; \text{otherwise} \end{cases} \quad (1)$$

where  $d_0$  is the mean half width of the non-stenotic region of the channel,  $L$  is the length of the channel,  $L_0$  is the length of stenosis and  $\delta$  is the maximum height of stenosis. (Fig.1.)

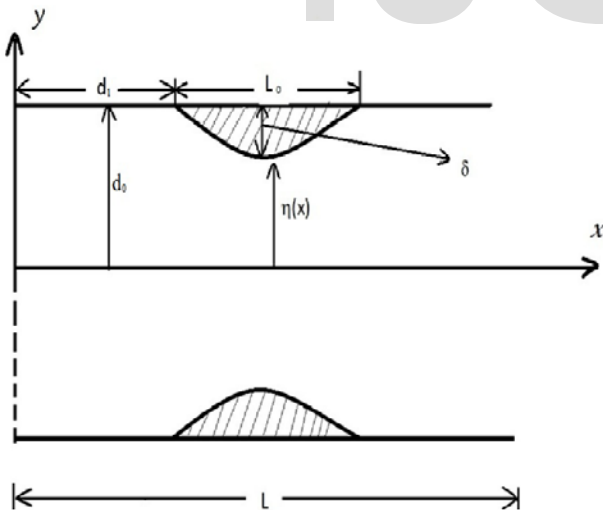

Fig.(1) Geometry of the channel with local stenosis

The equations governing the motion of an incompressible couple stress fluid flow for the present problem, by neglecting body forces and body couples, are given as (Alemayehu and Radhakrishnamacharya [15])

$$\frac{\partial u}{\partial x} + \frac{\partial v}{\partial y} = 0 \quad (2)$$

$$-\frac{\partial p}{\partial x} + \mu \frac{\partial^2 u}{\partial y^2} - \eta' \frac{\partial^4 u}{\partial y^4} - \frac{\mu}{\kappa_0} u = 0 \quad (3)$$

$$-\frac{\partial p}{\partial y} = 0 \quad (4)$$

where  $u$  and  $v$  are the velocity components along the  $x$  and  $y$  directions respectively,  $p$  is the pressure,  $\kappa_0$  is the permeability constant of the medium,  $\mu$  is the coefficient viscosity of classical fluid dynamics,  $\eta'$  is the couple stress fluid viscosity.

The boundary conditions are given by

$$u = \frac{-d_0 \sqrt{Da}}{\alpha_1} \frac{\partial u}{\partial y} \quad \text{at } y = \pm \eta \quad (5)$$

$$\frac{\partial^2 u}{\partial y^2} = 0 \quad \text{at } y = \pm \eta \quad (6)$$

Here (5) is the Saffman's slip boundary condition (Baht and Sacheti [16]) and (6) indicates the vanishing of couple stress. Further,  $Da$  is the permeability parameter (or Darcy number) and  $\alpha_1$  is the slip parameter.

Taking the restriction for mild stenosis (Young [2]) and solving (2)-(4) under the boundary conditions (5) and (6), the velocity is given as

$$u(y) = \frac{-\kappa_0}{\mu} \frac{\partial p}{\partial x} [R_2^* \cosh(m_1^* y) - R_1^* \cosh(m_2^* y) + 1] \quad (7)$$

where

$$m_1^* = \sqrt{\frac{\mu}{2\eta'} \left( 1 + \sqrt{1 - \frac{4\eta'}{\mu\kappa_0}} \right)}, \quad m_2^* = \sqrt{\frac{\mu}{2\eta'} \left( 1 - \sqrt{1 - \frac{4\eta'}{\mu\kappa_0}} \right)}$$

$$R_1^* = \frac{(m_1^*)^2 \cosh(m_1^* \eta)}{b_1^* - b_2^*}, \quad R_2^* = \frac{(m_2^*)^2 \cosh(m_2^* \eta)}{b_1^* - b_2^*}$$

$$b_1^* = (m_1^*)^2 \cosh(m_1^* \eta) \left[ \cosh(m_2^* \eta) + \frac{d_0 \sqrt{Da}}{\alpha_1} m_2^* \sinh(m_2^* \eta) \right]$$

$$b_2^* = (m_2^*)^2 \cosh(m_2^* \eta) \left[ \cosh(m_1^* \eta) + \frac{d_0 \sqrt{Da}}{\alpha_1} m_1^* \sinh(m_1^* \eta) \right] \quad b_1 = b_1^* d_0^2 = m_1^2 \cosh(m_1 H) \left[ \cosh(m_2 H) + \frac{\sqrt{Da}}{\alpha_1} m_2 \sinh(m_2 H) \right]$$

### 3 ANALYSIS

The flux  $Q$  of the fluid is given by

$$Q = 2 \int_0^\eta u dy = \frac{-2 \kappa_0}{\mu} \frac{\partial p}{\partial x} \left[ R_2^* \frac{\sinh(m_1^* \eta)}{m_1^*} - R_1^* \frac{\sinh(m_2^* \eta)}{m_2^*} + \eta \right] \quad (8)$$

Introducing the following dimensionless quantities

$$\delta^* = \frac{\delta}{d_0}, \quad x^* = \frac{x}{L}, \quad d_1^* = \frac{d_1}{L}, \quad L_0^* = \frac{L_0}{L},$$

$$H = \frac{\eta}{d_0}, \quad p^* = \frac{p}{\left( \frac{\mu UL}{\kappa_0} \right)}, \quad Q^* = \frac{Q}{U d_0} \quad (9)$$

in eq.(1) and eq.(9), we get ( after dropping asterisks)

$$Q = -2 \frac{\partial p}{\partial x} \left[ R_2 \frac{\sinh(m_1 H)}{m_1} - R_1 \frac{\sinh(m_2 H)}{m_2} + H \right] \quad (10)$$

where

$m (= d_0 m^* = d_0 (\mu / \eta')^{\frac{1}{2}})$  is a couple stress parameter,

$$Da = \frac{\kappa_0}{d_0^2}, \quad m_1 = m_1^* d_0 = \sqrt{\frac{m^2}{2} \left( 1 + \sqrt{1 - \frac{4}{m^2 Da}} \right)},$$

$$m_2 = m_2^* d_0 = \sqrt{\frac{m^2}{2} \left( 1 - \sqrt{1 - \frac{4}{m^2 Da}} \right)},$$

$$R_1 = \frac{m_1^2 \cosh(m_1 H)}{b_1 - b_2}, \quad R_2 = \frac{m_2^2 \cosh(m_2 H)}{b_1 - b_2}$$

$$b_2 = b_2^* d_0^2 = m_2^2 \cosh(m_2 H) \left[ \cosh(m_1 H) + \frac{\sqrt{Da}}{\alpha_1} m_1 \sinh(m_1 H) \right]$$

From eq.(10) we obtain

$$\frac{\partial p}{\partial x} = \frac{-Q}{2} \left( \frac{1}{R_2 \frac{\sinh(m_1 H)}{m_1} - R_1 \frac{\sinh(m_2 H)}{m_2} + H} \right) \quad (11)$$

Integrating eq.(11) with respect to  $x$ , we get pressure difference  $\Delta p$  along the total length of a channel as

$$\Delta p = \frac{Q}{2} \int_0^1 \left( \frac{1}{R_2 \frac{\sinh(m_1 H)}{m_1} - R_1 \frac{\sinh(m_2 H)}{m_2} + H} \right) dx \quad (12)$$

The resistance to flow, denoted by  $\lambda$ , is defined by

$$\lambda = \frac{\Delta p}{Q} \quad (13)$$

Using eq. (12) in eq. (13), we get

$$\lambda = \frac{1}{2} \int_0^1 \left( \frac{1}{R_2 \frac{\sinh(m_1 H)}{m_1} - R_1 \frac{\sinh(m_2 H)}{m_2} + H} \right) dx \quad (14)$$

The pressure drop in the case of no stenosis ( $H=1$ ), denoted by  $\Delta p_n$ , is obtained from eq. (12) as

$$\Delta p_n = \frac{Q}{2} \int_0^1 \left( \frac{1}{R_{22} \frac{\sinh(m_1)}{m_1} - R_{11} \frac{\sinh(m_2)}{m_2} + 1} \right) dx \quad (15)$$

where

$$R_{11} = \frac{m_1^2 \cosh(m_1)}{b_{11} - b_{22}}, \quad R_{22} = \frac{m_2^2 \cosh(m_2)}{b_{11} - b_{22}},$$

$$b_{11} = m_1^2 \cosh(m_1) \left[ \cosh(m_2) + \frac{\sqrt{Da}}{\alpha_1} m_2 \sinh(m_2) \right],$$

$$b_{22} = m_2^2 \cosh(m_2) \left[ \cosh(m_1) + \frac{\sqrt{Da}}{\alpha_1} m_1 \sinh(m_1) \right].$$

The resistance to flow in the absence of stenosis,  $\lambda_n$ , is defined by

$$\lambda_n = \frac{\Delta p_n}{Q} \quad (16)$$

Using eq. (15) in eq. (16), we obtain

$$\lambda_n = \frac{1}{2} \int_0^1 \left( \frac{1}{R_{22} \frac{\sinh(m_1)}{m_1} - R_{11} \frac{\sinh(m_2)}{m_2} + 1} \right) dx \quad (17)$$

The normalized resistance to the flow,  $\bar{\lambda}$ , is given by

$$\bar{\lambda} = \frac{\lambda}{\lambda_n} \quad (18)$$

The shear stress acting on the wall of the channel is given by

$$\tau_w = -\mu \left. \frac{\partial u}{\partial y} \right|_{y=\eta} \quad (19)$$

Introducing the dimensionless quantity

$$\tau_w^* = \frac{\tau_w}{\left( \frac{\mu U}{d_0} \right)} \quad (20)$$

and using eq.(15) in eq.(19), we get(after dropping asterisks)

$$\tau_w = \frac{-Q}{2} \left( \frac{R_2 m_1 \sinh(m_1 H) - R_1 m_2 \sinh(m_2 H)}{R_2 \frac{\sinh(m_1 H)}{m_1} - R_1 \frac{\sinh(m_2 H)}{m_2} + H} \right) \quad (21)$$

The shear stress at the wall in the absence of stenosis ( $H=1$ ), denoted by  $(\tau_w)_n$ , can be obtained from eq. (21) as

$$(\tau_w)_n = \frac{-Q}{2} \left( \frac{R_{22} m_1 \sinh(m_1) - R_{11} m_2 \sinh(m_2)}{R_{22} \frac{\sinh(m_1)}{m_1} - R_{11} \frac{\sinh(m_2)}{m_2} + 1} \right) \quad (22)$$

The normalized shear stress at the wall,  $\bar{\tau}_w$ , is given by

$$\bar{\tau}_w = \frac{\tau_w}{(\tau_w)_n} \quad (23)$$

#### 4 RESULTS AND DISCUSSIONS

The resistance to flow and the wall shear stress are the two important characteristics in the study of blood flow through a stenosed artery. The expressions for resistance to the flow and wall shear stress, given by eq.(18) and eq.(23) respectively have been numerically evaluated using MATHEMATICA software for different values of relevant parameters and presented graphically.

Figures (2)-(5) show the effects of various parameters on the resistance to flow in a uniform channel with mild stenosis. It can be observed that the resistance to flow increases with the height of stenosis (Figures 2-5). This result agrees with the previous results obtained by Young [2], Shukla et al. [7], Chaturani and Samy [17]. Further, it can be noticed that the resistance to flow increases with the slip parameter and the length of stenosis (Figures (2) and (3)) and with Darcy number (Figure 4) but decreases with couple stress parameter (Figure 5).

Figures (6)-(8) show the effects of various parameters on the wall shear stress. The wall shear stress increases with the height of stenosis (Figures 6-8). This result agrees with previous results obtained by Young [2], Lee and Fung [18], Shukla et al. [7]. Moreover, the wall shear stress increases with slip parameter (Figure 6) but decrease with Darcy number (Figure 7) and the couple stress parameter (Figure 8). However, the decrease of the couple stress parameter is not very significant (Figure 8).

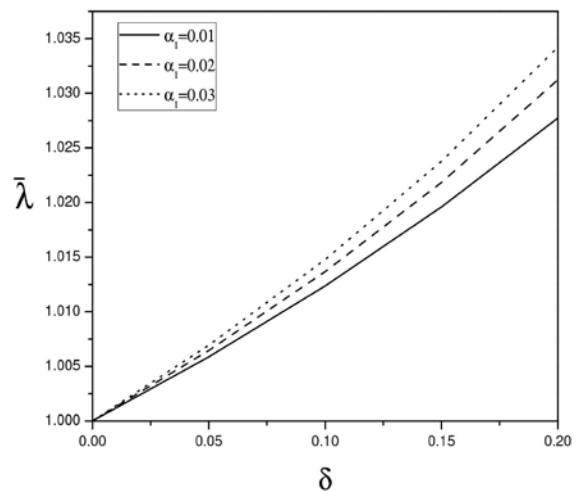

Figure(2) Effect  $\alpha_1$  on  $\bar{\lambda}$  ( $d_1 = 0.4, L_0 = 0.2, Da = 0.003, m = 0.2$ )

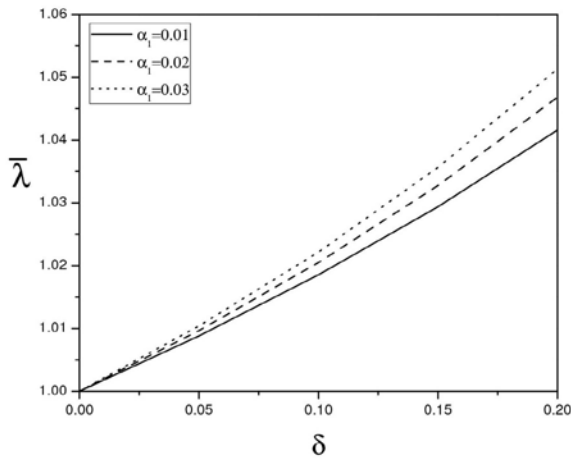

Figure(5) Effect of  $m$  on  $\bar{\lambda}$  ( $d_1 = 0.4, L_0 = 0.2, Da = 0.003, \alpha_1 = 0.02$ )

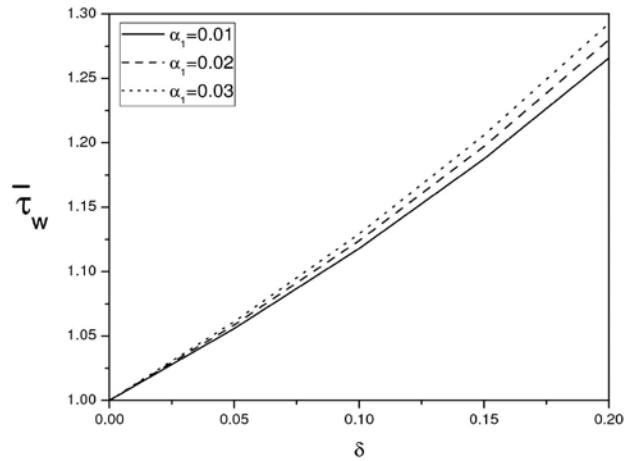

Figure(3). Effect  $\alpha_1$  on  $\bar{\lambda}$  ( $d_1 = 0.4, L_0 = 0.3, Da = 0.003, m = 0.2$ )

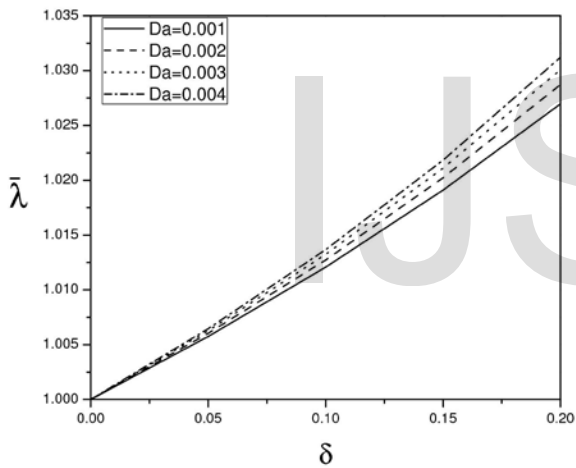

Figure(6) Effect of  $\alpha_1$  on  $\bar{\tau}_w$  ( $d_1 = 0.4, L_0 = 0.2, x = 0.5, m = 0.2, Da = 0.003$ )

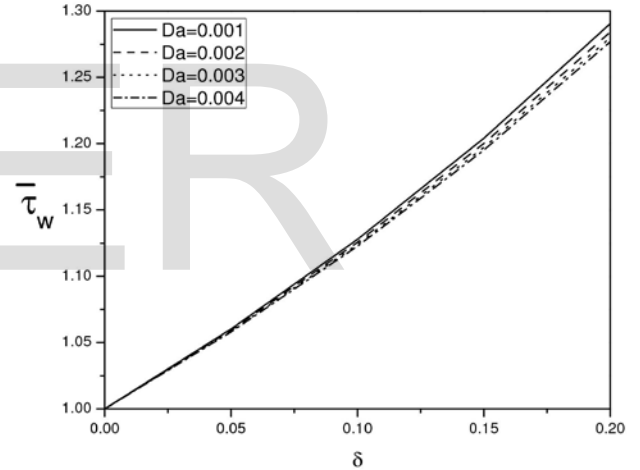

Figure(4) Effect of  $Da$  on  $\bar{\lambda}$  ( $d_1 = 0.4, L_0 = 0.2, \alpha_1 = 0.02, m = 0.2$ )

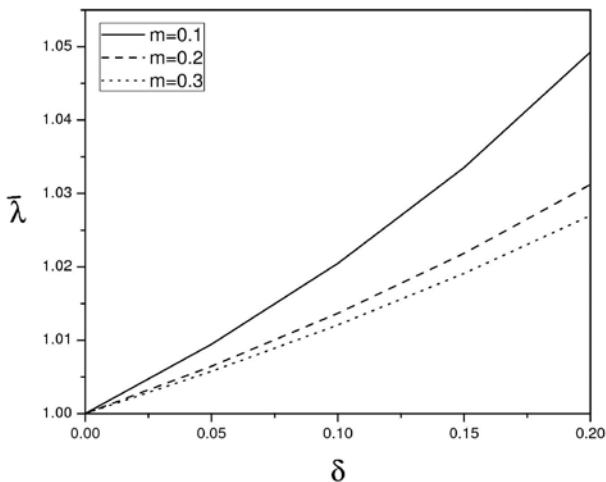
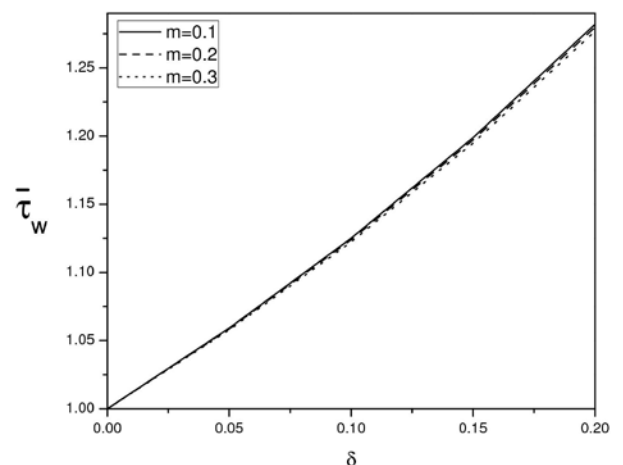

Figure 7. Effect of  $Da$  on  $\bar{\tau}_w$  ( $d_1 = 0.4, L_0 = 0.2, x = 0.5, m = 0.2, \alpha_1 = 0.02$ )



Figure(8) Effect of

$m$  on  $\overline{\tau_w}$  ( $d_1 = 0.4, L_0 = 0.2, x = 0.5, \alpha_1 = 0.02, Da = 0.003$ )

## 5. CONCLUSION

The flow of steady and an incompressible couple stress fluid through a porous medium with local stenosis has been presented. Solutions have been obtained for mild stenosis and using slip condition. It is obtained that both the resistance to flow and shear stress increase with height of stenosis  $\delta$ , and slip parameter  $\alpha_1$  but decrease with couple stress parameter  $m$ . Moreover, the resistance to flow increases with Darcy number Da. However, the wall shear stress decreases with Darcy number Da.

## References

- [1] R. E. Mates, R. L. Gupta, A. C. Bell and F. J. Klocke, "Fluid dynamics of coronary artery stenosis," *Circ. Res.*, vol. 42, pp. 152-162, 1978.
- [2] D. F. Young, "Effects of a time-dependent stenosis on flow through a tube," *J. Eng. Ind. Trans. ASME.*, vol. 90, pp. 248-254, 1968.
- [3] G. R. Zendehebudi and M. S. Moayeri, "Comparison of physiological and simple pulsatile flows through stenosed arteries," *J. Biomech.*, vol. 32, pp. 959-965, 1999.
- [4] G. Radhakrishnamacharya and P. Srinivasa Rao, "Flow of a magnetic fluid through a non-uniform wavy tube," *Proc. Nat. Acad. Sci. India*, vol. 76, 241-245, 2007
- [5] R. L. Whitmore, "Rheology of the Circulation," *Pergamon Press*, New York, 1968.
- [6] J. H. Forrester and D. F. Young, "Flow through a converging-diverging tube and its implications in occlusive vascular disease," *J. Biomech.*, vol. 3, pp. 307-316, 1970.
- [7] J. B. Shukla, R.S. Parihar and B. R. P. Rao, "Effects of stenosis on non-Newtonian flow of the blood in an artery," *Bull. Math. Biol.*, vol. 42, pp. 283-294, 1980.
- [8] J. C. Misra and G. C. Shit, "Blood flow through arteries in a pathological state: A theoretical Study," *Int. J. Engng. Sci.*, vol. 44, pp. 662-671, 2006.
- [9] V. K. Stokes, "Couple stresses in fluids," *Phys. Fluids*, vol. 9, pp. 1709-1715, 1966.
- [10] S. C. Cowin, "The theory of polar fluids, Advances in Applied Mechanics," Editor: C.S. Yih, 14, *Academic Press*, New York, pp. 279-347, 1974.
- [11] G. C. Sankad and G. Radhakrishnamacharya, "Effect of Magnetic field on the peristaltic transport of couple stress fluid in a channel with wall properties," *Int. J. Biomath.*, vol. 4, pp. 365-378, 2011.
- [12] D. Srinivasacharya and D. Srikanth, "Effect of couple stresses on the pulsatile flow through a constricted annulus," *Comptes Rendus Mecanique*, vol. 336, pp. 820-827, 2008.
- [13] D. Tong and H. Hu, "Flow analysis of non-Newtonian viscoelastic fluids in porous media," *J. Porous Media*, vol. 13, pp. 477-486, 2010.
- [14] J. C. Misra and S. K. Ghosh, "A mathematical model for the study of blood flow through a channel with permeable walls," *Acta Mechanica*, vol. 122, pp. 137-153, 1997.
- [15] H. Alemayehu and G. Radhakrishnamacharya, "Dispersion of a solute in peristaltic motion of a couple stress fluid in the presence of magnetic field," *International Journal of Engineering and Applied Sciences*, vol. 7, pp. 155-160, 2011.
- [16] B. S. Bhatt and N. C. Sacheti, "On the analogy in slip flows," *Indian Journal of Pure and Applied Mathematics*, vol. 10, pp. 303-306, 1979.
- [17] P. Chaturani and R. P. Samy, "Blood flow through stenosed arteries," *Proc. of First Int. Conf. of Physio. Fluid dynamics*, Madras, India, pp. 63-67, 1985.
- [18] J. S. Lee and Y. C. Fung, "Flow in locally constricted tubes at low Reynolds numbers," *J. Appl. Mech. Trans. ASME.*, vol. 37, pp. 9-16, 1970.