

Effect of Wind Energy Participation in AGC of Interconnected Multi-source Power Systems

Ibraheem Nasiruddin and Saab B Altamimi*

Department of Electrical Engineering, Engineering College, Qassim University, Kingdom of Saudi Arabia

Abstract

This paper presents the investigations on the effect of wind energy system's participation on dynamic stability margins available on AGC of interconnected power system. A two area power system model interconnected via EHV-AC tie-line is considered for the study. Each of the areas is consisting of hybrid sources of power generation like; hydro, thermal, gas and wind power plants. Various participation factors for electrical energy received from wind power plants, along with the energy from thermal, gas and hydro plants, are considered for the investigations. Moreover, any reduction of generation from thermal power plant is supposed to be supplied by wind power plant for fuel saving and to reduce emissions to environment. The optimal AGC regulators are designed using full state vector feedback control theory. Following the achievement of optimal gains of AGC regulators, the system closed-loop system eigenvalues are obtained for various case studies. The investigations of the closed loop eigenvalues carried out reveal that all the closed-loop eigenvalues are lying in the negative half of s-plan for all case studies and thus ensure the closed-loop system stability. Also, closed-loop eigenvalues are found to be sensitive to reduction in thermal generation and subsequent increase in electrical energy from wind power plants. It is also observed that the computed complex eigenvalues have shown a considerable decrease in the magnitude of its imaginary part when reduction of thermal generation is met by wind power generation. The reduced magnitudes of imaginary parts of closed-loop eigenvalues result in cost effective controller realization and improvement in system stability. On the other hand, the replacing the deficit caused in the supply with wind energy has no undesirable emissions to environment.

Keywords: Electrical energy; Automatic generation control; Wind energy; Solar energy; Eigenvalues

Introduction

The structure of today's power systems is huge and complex. A typical power system consists of large number of generators interconnected via networks of transmission lines, which provide power to consumers at nominal voltage and frequency. The maintenance of these parameters at the nominal values is necessary to achieve satisfactory operation of connected equipment with high efficiency and minimum wear and tear of the consumer equipment during their operation. Therefore, main parameters to be maintained properly are the system frequency and voltage profile. These parameters also responsible to dictate and determine the system stability and quality of the power supply. In a power system, frequency deviations are mainly due mismatch between real power generation and its demand, whereas voltage variations are function of reactive power imbalance in the system. The active and reactive power balance in the power system can be achieved by tracking the real and reactive power generation with continuously varying load demands. This can be done by designing and implementing effective schemes called automatic generation control (AGC) schemes. The control loops of these two parameters, assumed to be decoupled in nature and can be handled separately [1-3].

The modern power systems, from the operational and control point of view, are generally divided into control areas to form a coherent group of generators for sharing their technical, economic and operational benefits. Further to mitigate mismatch between generation and demand effectively and easily, these control areas are interconnected through tie lines for providing contractual exchange of power under normal operating conditions and even a quick assistance in emergency situations. Therefore, the control problem in power system is to maintain frequency and power exchanges between the areas at their rated values. The frequency deviation (ΔF) and tie-line flow deviation (ΔP_{tie}) can occur due to sudden area load changes. To minimize these deviations as soon as possible; a signal is generated by a

linear combination of ΔF and ΔP_{tie} ; known as area control error (ACE). Through the implementation of properly designed AGC schemes, the necessary change in generation is carried out by manipulation of speed changer of various generating units based on ACE minimization principles.

The fossil fuels such as coal, oil and natural gas, nuclear energy, hydro energy are commonly used energy sources at power plants for power generations. Since fossil fuels are depleting day by day, therefore, it is the need of the hour to go for non-conventional fuels like; solar energy, wind energy and many others for electricity generation. The power engineers have been engaging themselves for technology development in this area to harness electrical power from these fuels. The trend of adding a considerable amount of power from non-conventional energy sources is encouraging. With these developments, the control areas of power systems may supposed to have conventional and non-conventional sources of energy. The electricity generation scenario all over the world has different set of fuels exploited for electrical energy generation. In most of the countries, generally electricity is generated by hydro, thermal, gas and wind power plants. Among the nonconventional sources wind energy is considered to have a lion's share. Wind power is extracted from air flow using wind turbines for generating electricity. One of the major objectives

*Corresponding author: Saab B Altamimi, Department of Electrical Engineering, Engineering College, Qassim University, POB 6677-51452, Kingdom of Saudi Arabia, Tel: +966 16 380 0050; E-mail: saab_tam@hotmail.com

Received December 25, 2015; Accepted January 25, 2016; Published February 22, 2016

Citation: Ibraheem Nasiruddin, Saab B Altamimi (2016) Effect of Wind Energy Participation in AGC of Interconnected Multi-source Power Systems. J Electr Electron Syst 5: 175. doi:10.4172/2332-0796.1000175

Copyright: © 2016 Ibraheem Nasiruddin, et al. This is an open-access article distributed under the terms of the Creative Commons Attribution License, which permits unrestricted use, distribution, and reproduction in any medium, provided the original author and source are credited.

achieved by harnessing electrical energy from wind is reduce eliminate the emissions associated with thermal power plants. However, the operation of wind power plants with conventional power plants has a system stability problems due to uncertainty in the flow of natural wind energy. In addition to this, the task of AGC is carry out by conventional sources power plants but disturbance can also be influenced by deviation in wind energy [4-6]. Therefore, system stability analysis of power systems with hybrid energy sources is of prime importance before proposing any AGC scheme for such systems. In this work, a comprehensive system stability analysis is carried out considering different combination of wind and thermal power plants. The power contribution from other power plants is considered as constant due to economic and environmental considerations.

Brief Literature Survey

In literature, there are large number of publications appeared by considering various aspects of design and implementation of AGC schemes [1,2,7-28]. Most of the works on AGC of power systems are reviewed comprehensively [4-6]. The first attempt in this area was aimed to control the frequency of a power system via the flywheel and speed governor of the prime-mover of the generator set. Immediately the scheme was noticed insufficient to meet the objectives of AGC and therefore, the technique was augmented with a supplementary control and adjoined to the speed governor of the prime mover with the combination of PI control strategy based on frequency deviation (Δf) signal [10,11,29]. Later, the conventional AGC schemes are described by Cohn [30]. The modern control concept based on optimal control theory was presented by Elgerd and Fosha [1,2] to design AGC regulators power systems. They suggested a PI structured full state feedback form of controller for developing optimal AGC regulators. The use of sate feedback control has a serious drawback that all states must be measured, therefore, an idea of sub-optimal control designs mooted to circumvent these drawbacks of optimal AGC regulators [12,13]. Usually, sub-optimal AGC regulators failed to provide the desired system dynamic performance. The problem was handled by researchers to design optimal AGC regulators by reconstructing the unavailable states from the available outputs and controls by using an observer [14,15]. Over the last two decades have seen the application of artificial intelligent techniques such as; Fuzzy Logic, Artificial Neural Networks, Genetic Algorithm, Particle Swarm Optimization, Bacteria Foraging and Hybrid Intelligent Techniques as powerful tools for designing of AGC regulators in power systems. Many studies exploiting artificial intelligent techniques for the design of AGC regulators in power systems considering various system aspects are appeared in references [16-31].

Most of these AGC studies have been carried out for interconnected power systems by considering single source of power generation in a control area [1,2,7-28]. However, in practical situations, a control area may comprise of a mix of hydro, thermal, gas and non-conventional energy sources based power plants. Only few studies on AGC of power systems considering multi sources power plants in a control area are appeared [4,5,31-33]. However, in these power system models, the dynamics of the wind power plants is missing [31-33]. Since, wind energy has been regarded as one of the most popular renewable energy sources for electricity generation, a due attention must be paid to consider its effect on dynamics of a control area having multi-sources for energy generation [6].

The optimal AGC regulator designs based on optimal control concept are simple to design, less costly and offer robust performance, therefore, in this paper, vector feedback control theory is adapted

for designing and implementation of AGC schemes in power system model under consideration. The paper presents the design of full state feedback PI structured optimal AGC regulators for a 2-area interconnected power system consists of hydro, thermal, gas and wind power plants. Since wind power plants faced stability problems while operating with conventional power plants, therefore a comprehensive stability analysis is carried out by achieving various patterns of closed-loop system eigenvalues with the implementation of designed optimal AGC regulators. Various participation factors for wind energy are considered in overall power generation to meet the load demand on the system.

Power system model and case studies

A 2-area power system model consisting of hybrid source power plants with hydro, thermal, gas and wind turbines interconnected via EHV-AC tie line is selected for the study. Figure 1 represents the transfer function model of the system under consideration. The nomenclature and numerical data are given in reference [4].

In the power system model given above, all the thermal power plants are considered lumped together and represented by a single thermal plant dynamics. Similarly, hydro, gas and wind power plants are represented by respective single plant dynamics. The case studies identified for the study are given in Table 1. These case studies are identified based on different combination of sharing factor of power plants participating in AGC schemes. In this work, the reduction of generation from thermal power plants is considered to be supplied by wind power plants for saving of fuel and to reduce air pollution from thermal power plant.

Dynamic Modeling of Power System Under Investigation

The power system model under investigation is a linear continuous time-invariant system which can be represented by the following standard state space equations;

$$\frac{d}{dt} \underline{X} = A \underline{X} + B \underline{U} + \Gamma \underline{P}_d \quad (1)$$

$$\underline{Y} = C \underline{X} \quad (2)$$

Where, \underline{X} , \underline{U} , \underline{P}_d and \underline{Y} are state, control, disturbance and output vectors respectively. A, B, Γ and C are system, control, disturbance and output matrices of compatible dimensions. The matrices are developed based on system parameters and the operating point. The various state variables of power system model under investigation are described in Figure 1. For the power system model, defining the state variables as shown in transfer function model of the system as;

$$x_1 = \Delta F_1, \quad x_2 = \Delta P_{iel2}, \quad x_3 = \Delta F_2, \quad x_4 = \Delta P_{G1}, \quad x_5 = \Delta P_{R1}, \quad x_6 = \Delta X_{t1},$$

$$x_7 = \Delta P_{Gh1}, \quad x_8 = \Delta X_{h1}, \quad x_9 = \Delta X_{RH1}, \quad x_{10} = \Delta P_{Gg1}, \quad x_{11} = \Delta P_{FC1}, \quad x_{12} = \Delta P_{IP1},$$

$$x_{13} = \Delta X_{g1}, \quad x_{14} = \Delta P_{G12}, \quad x_{15} = \Delta P_{R12}, \quad x_{16} = \Delta X_{t2}, \quad x_{17} = \Delta P_{Gh2}, \quad x_{18} = \Delta X_{h2},$$

$$x_{19} = \Delta X_{RH2}, \quad x_{20} = \Delta P_{Gg2}, \quad x_{21} = \Delta P_{FC2}, \quad x_{22} = \Delta P_{IP2}, \quad x_{23} = \Delta X_{g2}, \quad x_{24} = \int ACE_1 dt, \quad x_{18} = \Delta X_{h2}$$

$$, \quad x_{19} = \Delta X_{RH2}, \quad x_{20} = \Delta P_{Gg2}, \quad x_{21} = \Delta P_{FC2}, \quad x_{22} = \Delta P_{IP2}, \quad x_{23} = \Delta X_{g2}, \quad x_{24} = \int ACE_1 dt,$$

$$x_{25} = \int ACE_2 dt, \quad x_{26} = \Delta P_{GW1}, \quad x_{27} = \Delta P_{GW2}$$

The system state, control and disturbance vectors for power system model under investigation are as;

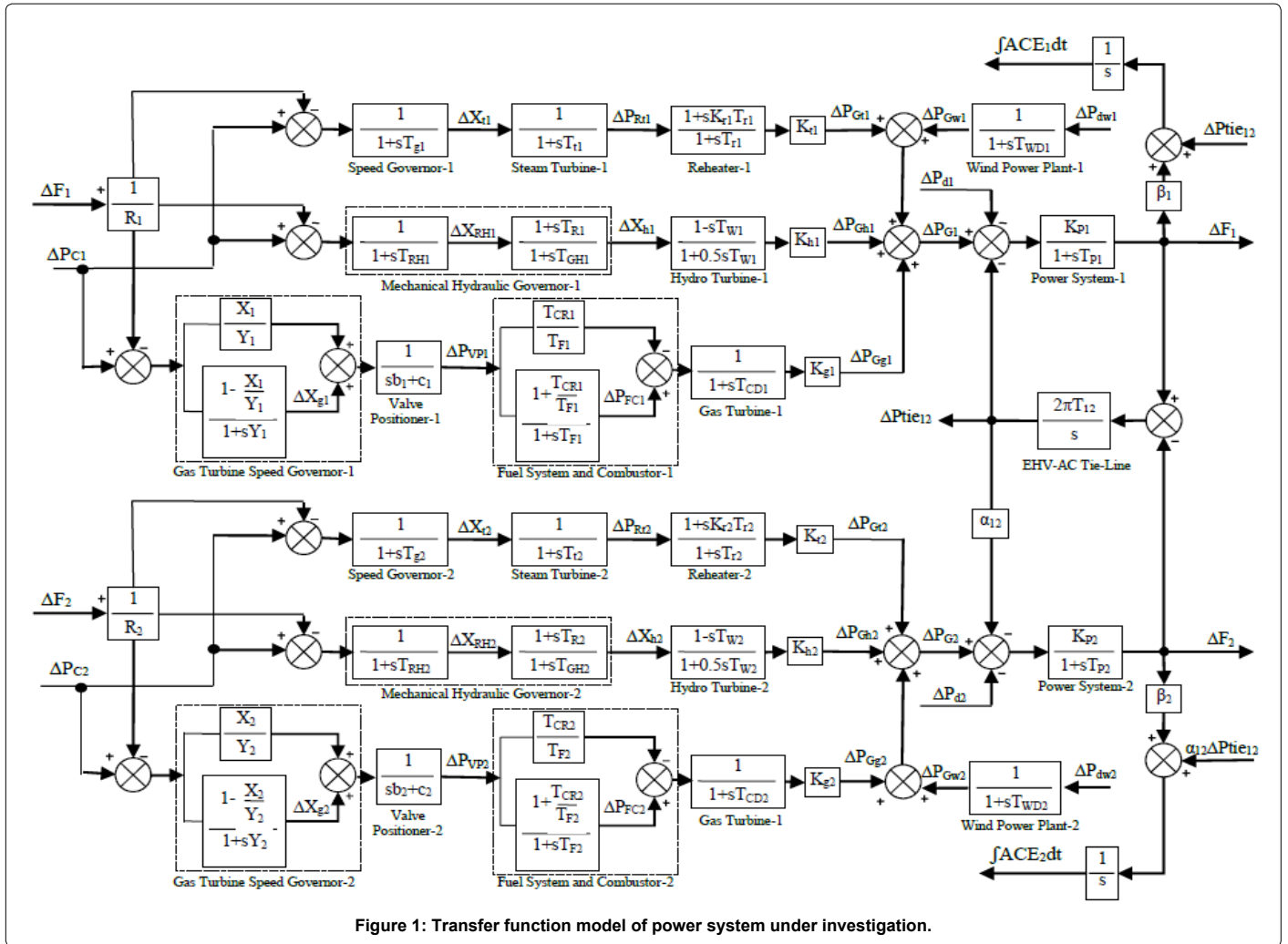

Figure 1: Transfer function model of power system under investigation.

➤ **State Vector**

$$[X]^T = \begin{bmatrix} x_1 & x_2 & x_3 & x_4 & x_5 & x_6 & x_7 & x_8 & x_9 & x_{10} \\ x_{11} & x_{12} & x_{13} & x_{14} & x_{15} & x_{16} & x_{17} & x_{18} & x_{19} & x_{20} \\ x_{21} & x_{22} & x_{23} & x_{24} & x_{25} & x_{26} & x_{27} \end{bmatrix}$$

Or

$$[X]^T = \begin{bmatrix} \Delta F_1 & \Delta P_{dt1} & \Delta F_2 & \Delta P_{dt2} & \Delta P_{G1} & \Delta P_{R1} & \Delta X_{t1} & \Delta P_{GH1} & \Delta X_{RH1} & \Delta P_{GV1} \\ \Delta P_{FC1} & \Delta P_{VP1} & \Delta X_{G1} & \Delta P_{G2} & \Delta P_{R2} & \Delta X_{t2} & \Delta P_{GH2} & \Delta X_{RH2} & \Delta P_{GV2} \\ \Delta P_{FC2} & \Delta P_{VP2} & \Delta X_{G2} & \int ACE_1 dt & \int ACE_2 dt & \Delta P_{Gw1} & \Delta P_{Gw2} \end{bmatrix} \quad (3)$$

➤ **Control Vector**

$$[U]^T = [\Delta P_{C1} \ \Delta P_{C2}] \quad (4)$$

➤ **Disturbance Vector**

$$[P_d]^T = [\Delta P_{d1} \ \Delta P_{d2} \ \Delta P_{dw1} \ \Delta P_{dw2}] \quad (5)$$

Dynamic equations

The following differential equations can be derived from transfer function model shown in Figure 1.

$$\frac{d}{dt}(x_1) = -\frac{1}{T_{P1}}x_1 - \frac{K_{P1}}{T_{P1}}x_2 + \frac{K_{P1}}{T_{P1}}x_4 + \frac{K_{P1}}{T_{P1}}x_7 + \frac{K_{P1}}{T_{P1}}x_{10} + \frac{K_{P1}}{T_{P1}}x_{26} - \frac{K_{P1}}{T_{P1}}\Delta P_{d1} \quad (6)$$

$$\frac{d}{dt}(x_2) = 2\pi T_{12}x_1 - 2\pi T_{12}x_3 \quad (7)$$

$$\frac{d}{dt}(x_3) = -\frac{\alpha_{12}K_{P2}}{T_{P2}}x_2 - \frac{1}{T_{P2}}x_3 + \frac{K_{P2}}{T_{P2}}x_{14} + \frac{K_{P2}}{T_{P2}}x_{17} + \frac{K_{P2}}{T_{P2}}x_{20} + \frac{K_{P2}}{T_{P2}}x_{27} - \frac{K_{P2}}{T_{P2}}\Delta P_{d2} \quad (8)$$

$$\frac{d}{dt}(x_4) = -\frac{1}{T_{r1}}x_4 + K_{t1}\left(\frac{1}{T_{r1}} - \frac{K_{r1}}{T_{t1}}\right)x_5 + \frac{K_{t1}K_{r1}}{T_{t1}}x_6 \quad (9)$$

$$\frac{d}{dt}(x_5) = -\frac{1}{T_{t1}}x_5 + \frac{1}{T_{t1}}x_6 \quad (10)$$

$$\frac{d}{dt}(x_6) = -\frac{1}{R_1T_{g1}}x_1 - \frac{1}{T_{g1}}x_6 + \frac{1}{T_{g1}}\Delta P_{C1} \quad (11)$$

$$\frac{d}{dt}(x_7) = \frac{2K_{h1}T_{R1}}{T_{GH1}R_1T_{RH1}}x_1 - \frac{2}{T_{w1}}x_7 + \left(\frac{2K_{h1}}{T_{w1}} + \frac{2K_{h1}}{T_{GH1}}\right)x_8 + \left(\frac{2K_{h1}T_{R1}}{T_{GH1}T_{RH1}} - \frac{2K_{h1}}{T_{GH1}}\right)x_9 - \frac{2K_{h1}T_{R1}}{T_{GH1}T_{RH1}}\Delta P_{C1} \quad (12)$$

$$\frac{d}{dt}(x_8) = -\frac{T_{R1}}{T_{GH1}R_1T_{RH1}}x_1 - \frac{1}{T_{GH1}}x_8 + \left(\frac{1}{T_{GH1}} - \frac{T_{R1}}{T_{GH1}T_{RH1}}\right)x_9 + \frac{T_{R1}}{T_{GH1}T_{RH1}}\Delta P_{C1} \quad (13)$$

$$\frac{d}{dt}(x_9) = -\frac{1}{R_1T_{RH1}}x_1 - \frac{1}{T_{RH1}}x_9 + \frac{1}{T_{RH1}}\Delta P_{C1} \quad (14)$$

$$\frac{d}{dt}(x_{10}) = -\frac{1}{T_{CD1}}x_{10} + \frac{K_{g1}}{T_{CD1}}x_{11} - \frac{K_{g1}T_{CR1}}{T_{F1}T_{CD1}}x_{12} \quad (15)$$

$$\frac{d}{dt}(x_{11}) = -\frac{1}{T_{F1}}x_{11} + \left(\frac{1}{T_{F1}} + \frac{T_{CR1}}{T_{F1}^2}\right)x_{12} \quad (16)$$

$$\frac{d}{dt}(x_{12}) = -\frac{X_1}{b_1R_1Y_1}x_1 - \frac{c_1}{b_1}x_{12} + \frac{1}{b_1}x_{13} + \frac{X_1}{b_1Y_1}\Delta P_{C1} \quad (17)$$

$$\frac{d}{dt}(x_{13}) = \left(\frac{X_1}{R_1Y_1^2} - \frac{1}{R_1Y_1}\right)x_1 - \frac{1}{Y_1}x_{13} + \left(\frac{1}{Y_1} - \frac{X_1}{Y_1^2}\right)\Delta P_{C1} \quad (18)$$

$$\frac{d}{dt}(x_{14}) = -\frac{1}{T_{r2}}x_{14} + K_{t2}\left(\frac{1}{T_{r2}} - \frac{K_{r2}}{T_{t2}}\right)x_{15} + \frac{K_{t2}K_{r2}}{T_{t2}}x_{16} \quad (19)$$

$$\frac{d}{dt}(x_{15}) = -\frac{1}{T_{t2}}x_{15} + \frac{1}{T_{t2}}x_{16} \quad (20)$$

$$\frac{d}{dt}(x_{16}) = -\frac{1}{R_2T_{g2}}x_3 - \frac{1}{T_{g2}}x_{16} + \frac{1}{T_{g2}}\Delta P_{C2} \quad (21)$$

$$\frac{d}{dt}(x_{17}) = -\frac{2K_{h2}T_{R2}}{T_{GH2}R_2T_{RH2}}x_3 - \frac{2}{T_{w2}}x_{17} + \left(\frac{2K_{h2}}{T_{w2}} + \frac{2K_{h2}}{T_{GH2}}\right)x_{18} + \left(\frac{2K_{h2}T_{R2}}{T_{GH2}T_{RH2}} - \frac{2K_{h2}}{T_{GH2}}\right)x_{19} - \frac{2K_{h2}T_{R2}}{T_{GH2}T_{RH2}}\Delta P_{C2} \quad (22)$$

$$\frac{d}{dt}(x_{18}) = -\frac{T_{R2}}{T_{GH2}R_2T_{RH2}}x_3 - \frac{1}{T_{GH2}}x_{18} + \left(\frac{1}{T_{GH2}} - \frac{T_{R2}}{T_{GH2}T_{RH2}}\right)x_{19} + \frac{T_{R2}}{T_{GH2}T_{RH2}}\Delta P_{C2} \quad (23)$$

$$\frac{d}{dt}(x_{19}) = -\frac{1}{R_2T_{RH2}}x_3 - \frac{1}{T_{RH2}}x_{19} + \frac{1}{T_{RH2}}\Delta P_{C2} \quad (24)$$

$$\frac{d}{dt}(x_{20}) = -\frac{1}{T_{CD2}}x_{20} + \frac{K_{g2}}{T_{CD2}}x_{21} - \frac{K_{g2}T_{CR2}}{T_{F2}T_{CD2}}x_{22} \quad (25)$$

$$\frac{d}{dt}(x_{21}) = -\frac{1}{T_{F2}}x_{21} + \left(\frac{1}{T_{F2}} + \frac{T_{CR2}}{T_{F2}^2}\right)x_{22} \quad (26)$$

$$\frac{d}{dt}(x_{22}) = -\frac{X_2}{b_2R_2Y_2}x_3 - \frac{c_2}{b_2}x_{22} + \frac{1}{b_1}x_{23} + \frac{X_2}{b_2Y_2}\Delta P_{C2} \quad (27)$$

$$\frac{d}{dt}(x_{23}) = \left(\frac{X_2}{R_2Y_2^2} - \frac{1}{R_2Y_2}\right)x_3 - \frac{1}{Y_2}x_{23} + \left(\frac{1}{Y_2} - \frac{X_2}{Y_2^2}\right)\Delta P_{C2} \quad (28)$$

$$\frac{d}{dt}(x_{24}) = \beta_1x_1 + x_2 \quad (29)$$

$$\frac{d}{dt}(x_{25}) = \alpha_{12}x_2 + \beta_2x_3 \quad (30)$$

$$\frac{d}{dt}(x_{26}) = -\frac{1}{T_{W1}}x_{26} + \frac{1}{T_{W1}}\Delta P_{dw1} \quad (31)$$

$$\frac{d}{dt}(x_{27}) = -\frac{1}{T_{W2}}x_{27} + \frac{1}{T_{W2}}\Delta P_{dw2} \quad (32)$$

Using these differential equations and the numerical data given in [32], all the system matrices; [A], [B] and [Γ] can be obtained. With the help of these matrices, the optimal AGC regulators of the power system model under consideration are designed using full state vector feedback control strategy. The derivation of PI structured optimal AGC regulators is described in [33].

Simulation of results

The state space model developed in previous section is simulated on MATLAB platform for all case studies as given in Table 1. The optimal feedback gains and associated performance index (J) values are obtained for PI structured optimal AGC regulators for all case studies. These are given in Table 2. Using these optimal gains, case-wise closed-loop system eigenvalues are computed to investigate the closed-loop system stability. These closed-loop system eigenvalues are shown in Table 3.

Results and Discussion

The performance index values shown by Table 2 are indicative of the cost aspects of physical realization of AGC regulators of the power system. The lower value of performance index will result in the cheaper optimal AGC regulator design. From the inspection of Table 2, it can be revealed performance index value is not increased with a reduction in share of thermal generation which is supplied by wind power plant under all case studies. However, optimal gains of AGC regulators are sensitive to variation in sharing factors of wind power plants for all case studies.

The observation of optimal closed-loop eigenvalues shown in Table 3 shows that system is stable under all case studies. However, all the eigenvalues corresponding to state variables of both areas show no significant change in the magnitude of their real parts. The magnitudes of eigenvalues of state variables corresponding to Sr. Nos. (1-13) are increased considerably but opposite trend is seen in the magnitudes of eigenvalues of state variables corresponding to Sr. No. (14-25). Moreover, the magnitudes of eigenvalues corresponds to Sr. no. (26-27) have no considerable change. The complex eigenvalues have shown a considerable reduction in the magnitude of its imaginary part for case studies 1-4. The reduced magnitudes of imaginary parts of closed-loop eigenvalues result in fast and smooth decay of dynamic system response. This is an additional contribution provided to system dynamics when reduction in thermal generation is supplied by wind power plants.

Conclusions

This paper presents a comprehensive stability analysis based on closed-loop system eigenvalues of a 2-area interconnected power system consisting of hybrid sources of power generation in each area. To carry out stability analysis of power system model under investigation, the reduction of generation from thermal power plant is supplied by wind power plant for fuel saving and to reduce emissions from thermal plants. The optimal AGC regulators are designed using full state vector feedback control theory. Following the achievement of optimal gains of AGC regulators, the system closed-loop eigenvalues

Case Study No.	Sharing factor of various energy sources for a scheduled generation in area-1				Sharing factor of various energy sources for a scheduled generation in area-2			
	Kt1	Kh1	Kg1	Kw1	Kt2	Kh2	Kg2	Kw2
1	0.6	0.30	0.10	0.00	0.6	0.30	0.10	0.00
2	0.5	0.30	0.10	0.10	0.5	0.30	0.10	0.10
3	0.4	0.30	0.10	0.20	0.4	0.30	0.10	0.20
4	0.3	0.30	0.10	0.30	0.3	0.30	0.10	0.30

Table 1: Case Studies.

x	Optimal Gains										Performance Index (J)
Case Study-1	0.6571	-1.8591	0.1430	6.7836	-0.6908	0.4749	2.2330	1.4607	0.2166		513.7227
	0.1430	1.8591	0.6571	1.2217	-0.1847	0.0053	0.3074	0.3645	-0.1487		
	1.0207	0.2644	0.2882	0.3052	1.2217	-0.1847	0.0053	0.3074	0.3645		
	0.1110	0.0068	0.0001	-0.0286	6.7836	-0.6908	0.4749	2.2330	1.4607		
Case Study-2	-0.1487	0.1110	0.0068	0.0001	-0.0286	1.0000	-0.0000	5.9267	1.3380		608.0909
	0.2166	1.0207	0.2644	0.2882	0.3052	-0.0000	1.0000	1.3380	5.9267		
	0.6358	-1.9126	0.1659	7.2603	-0.6090	0.4645	2.2418	1.5203	0.3395		
	0.1659	1.9126	0.6358	1.4444	-0.1820	0.0050	0.3533	0.3988	-0.1430		
Case Study-3	1.0049	0.2673	0.2901	0.3409	1.4444	-0.1820	0.0050	0.3533	0.3988		741.8015
	0.1341	0.0087	0.0004	-0.0206	7.2603	-0.6090	0.4645	2.2418	1.5203		
	-0.1430	0.1341	0.0087	0.0004	-0.0206	1.0000	-0.0000	6.2827	1.5551		
	0.3395	1.0049	0.2673	0.2901	0.3409	0.0000	1.0000	1.5551	6.2827		
Case Study-4	0.6094	-1.9633	0.1937	7.8374	-0.5115	0.4538	2.2435	1.5838	0.5045		941.2288
	0.1937	1.9633	0.6094	1.7306	-0.1747	0.0045	0.4098	0.4385	-0.1308		
	0.9835	0.2699	0.2918	0.3807	1.7306	-0.1747	0.0045	0.4098	0.4385		
	0.1629	0.0111	0.0008	-0.0106	7.8374	-0.5115	0.4538	2.2435	1.5838		
Case Study-4	-0.1308	0.1629	0.0111	0.0008	-0.0106	1.0000	-0.0000	6.7036	1.8282		941.2288
	0.5045	0.9835	0.2699	0.2918	0.3807	-0.0000	1.0000	1.8282	6.7036		
	0.5761	-2.0071	0.2283	8.5530	-0.3927	0.4427	2.2344	1.6509	0.7325		
	0.2283	2.0071	0.5761	2.1096	-0.1605	0.0036	0.4809	0.4854	-0.1082		
Case Study-4	0.9544	0.2720	0.2935	0.4255	2.1096	-0.1605	0.0036	0.4809	0.4854		941.2288
	0.1996	0.0144	0.0014	0.0019	8.5530	-0.3927	0.4427	2.2344	1.6509		
	-0.1082	0.1996	0.0144	0.0014	0.0019	1.0000	0.0000	7.2107	2.1801		
	0.7325	0.9544	0.2720	0.2935	0.4255	0.0000	1.0000	2.1801	7.2107		

Table 2: Optimal Feedback Gains.

Sr. No.	Case Study-1	Case Study-2	Case Study-3	Case Study-4
1	-24.6963	-24.6947	-24.6931	-24.6914
2	-24.6962	-24.6947	-24.6931	-24.6914
3	-15.4985	-15.4933	-15.4879	-15.4823
4	-15.4978	-15.4927	-15.4874	-15.4819
5	-0.4175 + 1.9743i	-0.3709 + 1.9674i	-0.3258 + 1.9601i	-0.2827 + 1.9526i
6	-0.4175 - 1.9743i	-0.3709 - 1.9674i	-0.3258 - 1.9601i	-0.2827 - 1.9526i
7	-2.3003	-2.2823	-2.2649	-2.2479
8	-2.2129	-2.2041	-2.1953	-2.1866
9	-1.1605 + 0.7841i	-1.1189 + 0.7322i	-1.0795 + 0.6742i	-1.0428 + 0.6088i
10	-1.1605 - 0.7841i	-1.1189 - 0.7322i	-1.0795 - 0.6742i	-1.0428 - 0.6088i
11	-1.4949	-1.5114	-1.527	-1.5421
12	-0.1547 + 0.0937i	-0.1445 + 0.0875i	-0.1337 + 0.0801i	-0.1221 + 0.0711i
13	-0.1547 - 0.0937i	-0.1445 - 0.0875i	-0.1337 - 0.0801i	-0.1221 - 0.0711i
14	-5.4948	-5.4966	-5.4984	-5.5002
15	-5.4688	-5.4703	-5.4719	-5.4734
16	-4.1996	-4.2074	-4.2163	-4.2263
17	-4.0908	-4.0912	-4.093	-4.0973
18	-3.8327	-3.8757	-3.9147	-3.9488
19	-3.8131	-3.8361	-3.8572	-3.8763
20	-1.2014	-1.1972	-1.1937	-1.1907
21	-1.0945	-1.0988	-1.1035	-1.1086
22	-0.3357	-0.3287	-0.32	-0.3091

23	-0.2537	-0.2453	-0.2344	-0.2198
24	-0.0312	-0.0323	-0.0339	-0.0361
25	-0.0312	-0.0324	-0.0339	-0.0363
26	-0.2	-0.2	-0.2	-0.2
27	-0.2	-0.2	-0.2	-0.2

Table 3: Closed-loop System Eigenvalues.

are obtained for various case studies under investigation. It has been found that the closed-loop system stability is ensured under all operating conditions as identified in various case studies. The system closed-loop eigenvalues are found to be sensitive to reduction in thermal generation when this reduced generation is supplied by wind power plants. It is also observed that the complex eigenvalues have a considerable reduction in the magnitude of its imaginary part when there is a reduction of power generation from thermal plants and this power is supplied by wind power plants. The reduced magnitudes of imaginary parts of closed-loop eigenvalues result in fast and smooth decay of system dynamic response. The high participation factor of wind power plants is an additional merit to reduce the emissions from thermal plants to the environment.

References

- Elgerd, Olle I, Fosha CE (1970) Optimum megawatt-frequency control of multi-area electric energy systems. *IEEE Transactions on Power Apparatus and Systems PAS-89* 4: 556-563.
- Fosha CE, Olle EI (1970) The Megawatt Frequency Control Problem: A New Approach Via Optimal Control Theory. *IEEE Transactions on Power Apparatus and Systems PAS-89* 4: 563-577.
- Kundur P (1994) *Power System Stability and Control*, McGraw-Hill: New York, USA.
- Ibraheem, Nasiruddin, Bhatti TS, Hakimuddin N (2015) Automatic generation control in an interconnected power system incorporating diverse source power plants using bacteria foraging optimization technique. *Electric Power Components and Systems* 43: 189-199.
- Nizamuddin (2013) *Automatic Generation Control of Multi Area Power Systems with Hybrid Power Generation Sources*, Ph. D Thesis, Jamia Millia Islamia, New Delhi, India.
- Völler S, Al-Awaad AR, Verstege JF (2009) Wind farms with energy storages integrated at the control power market. *CIGRE/IEEE PES Joint Symposium on Integration of wide-scale Renewable Resources into the Power Delivery System*, Calgary, Paris pp: 1-13.
- Ibraheem, Kumar P, Kothari DP (2005) Recent philosophies of automatic generation control strategies in power systems. *IEEE Transactions on Power Systems* 20: 346-357.
- Kumar P, Ibraheem (1996) AGC strategies: a comprehensive review. *Int Journal of Power and Energy Systems* 16: 371-376.
- Ibraheem, Kumar P, Khatoon S (2006) Overview of power system operational and control philosophies. *Int Journal of Power and Energy Systems* 26: 1-11.
- Concordia C, Kirchmayer LK (1953) Tie line power and frequency control of electric power systems. *AIEE Transactions on Power Apparatus and Systems* 72: 562-572.
- Concordia C, Kirchmayer LK (1954) Tie-line power and frequency control of electric power systems-Part III. *AIEE Transactions on Power Apparatus and Systems* 73: 133-146.
- Nasiruddin I, Kumar P, Hasan N, Nizamuddin (2012) Sub-optimal AGC of interconnected power system using output vector feedback control strategy. *Electric Power Components and Systems* 40: 977-994.
- Hasan N, Nasiruddin I, Kumar P, Nizamuddin (2012) Sub-optimal automatic generation control of interconnected power system using constrained feedback control strategy. *Int Journal of Electrical Power & Energy Systems* 43: 295-303.
- Rubaa A, Udo V (1992) An Adaptive Control Scheme for Load Frequency Control of Multi Area Power Systems Part-I: Identification and functional design. *Electric power Systems Research* 24: 183-188.
- Rubaa A, Udo V (1992) An adaptive control scheme for load frequency control of multiarea power systems Part-II: Implementation and test results by simulation. *Electric power Systems Research* 24: 189-197.
- Wu QH, Hogg BW, Irwin GW (1992) A Neural Network Regulator for Turbogenerators. *IEEE Transactions on Neural Networks* 3: 95-100.
- Douglas LD, Green TA, Kramer RA (1994) New approaches to the AGC nonconforming load problem. *IEEE Transactions on Power Systems* 9: 619-628.
- Chaturvedi DK, Satsangi PS, Kalra PK (1999) Load frequency control: A generalized neural network approach. *Int Journal of Electrical Power & Energy Systems* 21: 405-415.
- Zeynelgil HL, Demiroren A, Sengor NS (2002) The application of ANN technique to automatic generation control for multi-area power system. *Int Journal of Electrical Power & Energy Systems* 24: 345-354.
- Saikia LC, Mishra S, Sinha N, Nanda J (2011) Automatic generation control of a multi area hydrothermal system using reinforced learning neural network controller. *Int Journal of Electrical Power & Energy Systems* 33: 1101-1108.
- Oysal Y (2005) A comparative study of adaptive load frequency controller designs in a power systems with dynamic neural network models. *Energy Conversion and Management* 46: 2656-2668.
- Talaq J, Al-Basri F (1999) Adaptive fuzzy gain scheduling for load-frequency control. *IEEE Transactions on Power Systems* 14: 145-150.
- Kocaarslan I, Çam E (2005) Fuzzy Logic Controller in Interconnected Electrical Power Systems for Load-Frequency Control. *Int Journal of Electrical Power & Energy Systems* 27: 542-549.
- Çam E (2007) Application of fuzzy logic for load frequency control of hydro electrical power plants. *Energy Conversion and Management* 48: 1281-1288.
- Yeşil E, Güzelkaya M, Eksin I (2004) Self Tuning Fuzzy PID Type Load and Frequency Controller. *Energy Conversion and Management* 45: 377-390.
- Ei-Sherbiny MK, El-Saady G, Yousef AM (2002) Efficient fuzzy logic load-frequency controller. *Energy Conversion and Management* 43: 1853-1863.
- Abdel-Magid YL, Dawoud MM (1996) Optimal AGC Tuning with Genetic Algorithms. *Electric Power Systems Research* 38: 231-238.
- Abdenour A (2002) Adaptive optimal gain scheduling for the load frequency control problem. *Electric Power Components and Systems* 30: 45-56.
- Kirchmayer LK (1959) *Economic Control of Interconnected Systems*, New York: John Wiley & Sons.
- Cohn N (1961) *Control of Generation and Power Flow on Interconnected Systems*, New York: Wiley.
- Ramakrishna KSS, Sharma P, Bhatti TS (2010) Automatic generation control of interconnected power system with diverse sources of power generation. *Int Journal of Engineering, Science and Technology* 2: 51-65.
- Ramakrishna KSS, Bhatti TS (2007) Sampled-data automatic load frequency control of a single area power system with multi-source power generation. *Electric Power Components and Systems* 35: 955-980.
- Ibraheem, Nizamuddin, Bhatti TS (2014) AGC of Two Area Power System Interconnected by AC/DC Links with Diverse Sources in each Area. *Int Journal of Electrical Power & Energy Systems* 55: 297-304.