

Effectiveness of Flying Squirrel Excluder Devices on Red-cockaded Woodpecker Cavities

Susan C. Loeb, USDA Forest Service, Southern Research Station,
Department of Forest Resources, Clemson University,
Clemson, SC 29634

Abstract: I tested the effectiveness of squirrel excluder devices (SQEDs) in deterring southern flying squirrels (*Glaucomys volans*) from using artificial red-cockaded woodpecker (*Picoides borealis*) cavities by placing them on approximately one-half of the cavities in 14 inactive recruitment clusters on the Savannah River Site, South Carolina. SQEDs consisted of 2 pieces of 35.5-cm wide aluminum flashing placed 7.6 cm above and below the cavity entrance. Cavities with ($N = 37$) and without ($N = 35$) SQEDs were checked once per month from February 1995 to January 1996; all flying squirrels found in cavities were removed and destroyed. Cavities with and without SQEDs did not differ in cavity height ($P = 0.70$), distance to first branch >1 m in length ($P = 0.09$), distance to the nearest tree ($P = 0.29$), number of trees within 8 m ($P = 0.82$), or previous use by flying squirrels ($P = 0.67$). Flying squirrels used cavities without SQEDs throughout the year and occupied 5.7% to 38.2% of the cavities/month. In contrast, only 1 flying squirrel was found in a cavity with a SQED; thus, SQEDs effectively impeded flying squirrels from using red-cockaded woodpecker cavities and should be considered a tool in red-cockaded woodpecker management where flying squirrels are a potential threat to population stability or expansion.

Proc. Annu. Conf. Southeast Assoc. Fish and Wildl. Agencies 50:303-311

The endangered red-cockaded woodpecker (RCW) is highly dependent on the cavities it excavates in living pines (*Pinus* spp.) for survival and reproduction (Ligon 1970). Each bird roosts in an exclusive cavity year round and nesting usually occurs in the cavity of the breeding male. The lack of sufficient cavities is a major limiting factor in both population maintenance (Ligon 1970) and expansion (Copeyon et al. 1991, Heppell et al. 1994). Limited availability of cavities results from long excavation times (Hooper et al. 1980, Conner and Rudolph 1995), limited numbers of trees with sufficient heartwood and red-heart fungus (*Phellinus pini*) decay for cavity excavation (Hooper 1988), cavity tree mortality (Conner et al. 1991), and use of cavities by other species (Dennis 1971, Jackson 1978). Many species of vertebrates use RCW cavities, including southern flying squirrels, other woodpecker species, several cavity-

nesting passerines, and snakes (Dennis 1971, Jackson 1978, Harlow and Lennartz 1983, Rudolph et al. 1990a, Kappes 1993, Loeb 1993).

Southern flying squirrels are the most prevalent non-target users of RCW cavities in South Carolina (Dennis 1971, Harlow and Lennartz 1983), Georgia (Loeb 1993), and Texas (Rudolph et al. 1990a), and the second most prevalent user of RCW cavities in Mississippi (Jackson 1978) and Florida (Kappes 1993). Use of cavities by flying squirrels has been associated with nest loss of RCWs (Lennartz and Heckel 1987, LaBranche and Walters 1994) and inter-cluster movements of individuals (Jackson 1990). Although nest loss and inter-cluster movement may have few consequences in large populations, their effects in small populations are unknown. Management of several small populations of RCWs includes removal of flying squirrels from RCW cavities (e.g., DeFazio et al. 1987, Gaines et al. 1995, Montague et al. 1995, Richardson and Stockie 1995). Although no experimental tests have been conducted, it is hypothesized that squirrel removal is an important management activity contributing to the stabilization and growth of small populations (Gaines et al. 1995, Montague et al. 1995, Richardson and Stockie 1995); however, removal of squirrels from cavities is time consuming and expensive (E. LeMaster, pers. commun.).

In 1991, Montague et al. (1995) developed a squirrel excluder device (SQED) to prevent use of RCW cavities by flying squirrels on the Ouachita National Forest, Arkansas. They wrapped aluminum flashing around the bole of the tree above and below the cavity so that a squirrel could only enter the cavity if it glided or jumped to the exposed bark between the strips of flashing. SQEDs were placed on cavities that were being used by flying squirrels and the flying squirrels and nest material were removed. In 8 of 10 cases, flying squirrels eventually abandoned the cavities and the cavities were subsequently reoccupied by RCWs. These results suggest that SQEDs might be an effective and cost efficient device for preventing RCW cavity usurpation by flying squirrels; however, Montague et al. (1995) did not include non-SQED trees (controls) in their field trials, so their results are difficult to evaluate.

My objective was to experimentally test the effectiveness of SQEDs in deterring southern flying squirrels from using RCW cavities. I compared use of cavities with and without SQEDs by southern flying squirrels in inactive recruitment stands (i.e., sites that are managed for RCWs in hopes that they will occupy the area) with artificial cavity inserts. No attempt was made to evaluate the acceptance of SQEDs by RCWs.

This project was supported by the Department of Energy, Savannah River Site, and the USDA Forest Service, Savannah River Forest Station. I thank P. Johnson and D. Ussery for their assistance in squirrel removal. G. Chapman and T. Ridley assisted in SQED installation and data collection. R. N. Conner, J. W. Edwards, E. LeMaster, W. G. Montague and J. C. Neal reviewed earlier drafts of this manuscript. T. Ridley drafted the figure.

Methods

The study was conducted on the Department of Energy's Savannah River Site (SRS) in Aiken, Barnwell, and Allendale counties, South Carolina. Approximately

78,000 ha in size, the site is located in the Upper Coastal Plain physiographic region. Soils are generally well-drained, sandy, and of low fertility (Batson et al. 1985). When the Department of Energy acquired the site in 1950, much of the accessible land was logged; thus, most of the site is young (≤ 50 years) forest managed by the USDA Forest Service, Savannah River Forest Station. Approximately 15,000 ha are in hardwoods, 4,000 ha are in mixed pine-hardwoods, and 50,000 ha are in pines (Workman and McLeod 1990).

Intensive research and management of the SRS population of RCWs has occurred since 1985, when the population was at 4 individuals (Gaines et al. 1995). Since then, the population has grown to 65 to 70 individuals in 21 clusters. Management activities include hardwood midstory control in all cluster sites and recruitment stands, population monitoring, translocation of birds from other populations, translocation of birds within the population, installation of artificial cavity inserts, and flying squirrel removal. Artificial cavity inserts were placed in existing clusters, both active and inactive, and in recruitment stands. Twenty-four recruitment clusters were established between August 1991 and January 1995; eight are now active (i.e., occupied by ≥ 1 RCW).

Fourteen inactive recruitment clusters were included in the study. Each cluster was provisioned with 3 to 8 artificial cavity inserts between August 1991 and May 1994. Insert cavities were placed at either 3.4 to 4.3 m or 6.1 to 7.3 m in height. Cavities in 9 of the clusters were checked monthly and all flying squirrels removed from the time of installation to the onset of the study. The presence of other vertebrate species was recorded. In 5 clusters, cavities were screened closed and not checked for 2 to 4 months prior to the study, but were checked during the months prior to screening. Screens were removed when SQEDs were installed. In most clusters, SQEDs were placed on one-half the trees with artificial cavity inserts; the remaining trees with inserts served as controls. Trees to receive SQEDs were selected randomly; however, some of the trees could not be used because a branch or knob prevented placement of the SQED. In these cases, the SQED was placed on a control tree and the intended SQED tree became a control.

Each SQED consisted of 2 pieces of 35.5cm wide aluminum flashing wrapped around the bole of the tree and fastened with felt-paper nails. The flashing was placed approximately 7.6 cm above and below the cavity entrance (Fig. 1). The top 5 cm were folded at a 90° angle to the tree to prevent resin from flowing down the SQED and providing a travel route for squirrels (Montague et al. 1995).

Thirty-eight SQEDs were installed in January 1995 and cavities in all clusters were checked monthly from February 1995 to January 1996. The number of cavities checked each month varied slightly. The SQED was removed from a tree because a bird was translocated to it in March 1995. A tree fell against another cavity with a SQED and it could not be checked for 3 months, April to June. Finally, a non-SQED tree died in June and was no longer safe to climb. Most flying squirrels found in cavities were removed and destroyed by cervical dislocation. This method of euthanasia for southern flying squirrels was approved by the Clemson University Animal Research Committee (#93-053). A small number of flying squirrels escaped before

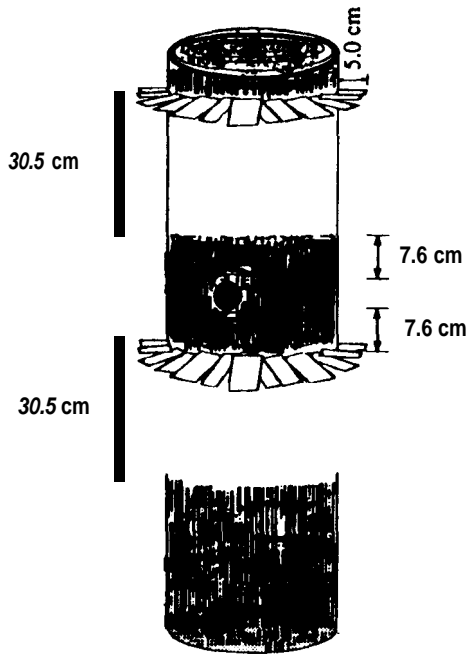

Figure 1. Diagrammatic sketch of a squirrel excluder device (SQED) and its position relative to the RCW cavity entrance.

they could be captured. The presence of other species in cavities was recorded, but the animals were not removed.

To establish that tree and cavity characteristics were similar between SQED and non-SQED trees and that any difference in cavity use was due to the presence or absence of SQED's, I measured cavity height, distance from the cavity to the first branch, live or dead, ≥ 1 m in length above the cavity, distance to the nearest tree, live or dead, 24 cm diameter breast height (dbh), and number of trees 24 cm dbh within 8 m. Log-likelihood G-tests were used to compare use of SQED and non-SQED cavities by flying squirrels and *t*-tests were used to compare characteristics of SQED and non-SQED trees and cavities.

Results

Characteristics of trees and cavities with and without SQEDs were similar (Table 1). Cavity height ($t = 0.39$, $df = 70$, $P = 0.70$), distance to first branch ($t = 1.73$, $df = 70$, $P = 0.09$), number of trees within 8 m ($t = 0.23$, $df = 70$, $P = 0.82$), and distance to the nearest tree ($t = 1.07$, $df = 70$, $P = 0.29$) did not differ between trees with and without SQEDs. Cavities with and without SQEDs had similar histories of flying squirrel use prior to the study, with flying squirrels using cavities in similar proportions ($G = 0.18$, $df = 1$, $P = 0.67$). Further, the time since cavities were last used by flying squirrels was not different between cavities with and without SQEDs ($t = 0.73$, $df = 45$, $P = 0.47$).

Table 1. Characteristics of RCW trees and artificial cavities with and without SQEDs on the Savannah River Site, South Carolina. Means \pm SE are presented.

Tree or cavity characteristic	Trees with SQEDs (N = 37)	Trees without SQEDs (N = 35)
Cavity height (m)	4.4 \pm 0.22	4.5 \pm 0.24
Distance to 1st branch (m)	3.9 \pm 0.50	2.8 \pm 0.45
N trees within 8 m	2.6 \pm 0.46	2.8 \pm 0.47
Distance to nearest tree (m)	6.1 \pm 0.49	5.4 \pm 0.40
N (%) previously used by flying squirrels	25 (67.6%)	22 (62.9%)
N (%) previously used by other species	4 (11.4%)	4 (10.8%)
N months since use by flying squirrels	6.4 \pm 1.3	5.1 \pm 1.0

Use of artificial cavities with and without SQEDs by flying squirrels differed significantly over the year ($G = 106.2$, $df = 1$, $P < 0.001$). Only 1 flying squirrel used a cavity with a SQED during the entire study. In contrast, flying squirrels used cavities without SQEDs throughout the year (Table 2). Use of cavities without SQEDs by flying squirrels varied seasonally. Highest use occurred in spring and late fall to early winter, and lowest use occurred in late winter and late summer. The numbers of flying squirrels/cavity ranged from 1 to 5 with the largest groups occurring in November and January. At least one non-SQED cavity was used by a flying squirrel in every RCW recruitment cluster.

Other species used cavities, although in much lower numbers than flying squirrels. Rat snakes (*Elaphe* spp.) were found in 3 cavities, 2 with SQEDs and 1 without. One red-bellied woodpecker (*Melanerpes carolinus*) was confirmed roosting in a

Table 2. Southern flying squirrel (SFS) use of artificial cavities with and without SQEDs in inactive RCW recruitment clusters on the Savannah River Site, South Carolina, February 1995 to January 1996.

Month	Cavities with SQEDs			Cavities without SQEDs		
	N cavities inspected	N (%) cavities with SFS	N SFS using cavities	N cavities inspected	N (%) cavities with SFS	N SFS using cavities
Feb	38	0 (0.0)	0	34	4 (11.8)	5
Mar	37	0 (0.0)	0	35	2 (5.7)	3
Apr	36	0 (0.0)	0	35	7 (20.0)	12
May	36	0 (0.0)	0	35	8 (22.9)	14
Jun	36	1 (2.8)	1	34	5 (14.7)	10
Jul	37	0 (0.0)	0	34	6 (17.6)	8
Aug	37	0 (0.0)	0	34	3 (8.8)	5
Sep	37	0 (0.0)	0	34	2 (5.9)	2
Oct	37	0 (0.0)	0	34	4 (11.8)	8
Nov	37	0 (0.0)	0	34	13 (38.2)	26
Dec	37	0 (0.0)	0	34	8 (23.5)	13
Jan	37	0 (0.0)	0	34	12 (35.3)	27
Combined	442	1 (0.2)	1	411	74 (18.0)	133

cavity without a SQED. Several additional cavities, both with and without SQEDs, were suspected of being used for roosting by red-bellied woodpeckers.

Discussion

The SQEDs were extremely effective in deterring southern flying squirrels from using inactive artificial RCW cavities. Only 1 cavity with a SQED was used during the entire year, while cavities without SQEDs were used throughout the year. The cavity with a SQED that was used by a flying squirrel was similar to the other cavities, both with and without SQEDs. One characteristic that may have made this cavity more susceptible to use by flying squirrels than other cavities with SQEDs was the distance to the first branch ≥ 1 m in length. The branch was only 1.5 m above the cavity, well below the average for both SQED and non-SQED cavities. A branch just above the SQED may allow a squirrel to jump to the exposed bark between the upper and lower pieces of flashing; thus, SQEDs placed on trees with branches close to the cavity entrance may be less effective than those on trees with no branches near the cavity. Although it did not happen in this study, I hypothesize that a similar occurrence is possible if another tree is close to the cavity tree.

The SQEDs did not appear to be effective in preventing use of cavities by snakes. Although only 2 snakes used cavities with SQEDs, this is relatively high compared to previous cavity use by snakes in active and inactive clusters on SRS. From 1985 to 1994, there were only 6 instances of cavity use by snakes in 10,347 cavity checks (D. Lotter, unpubl. data); however, all the trees examined in the present study were inactive and had little or no fresh resin present. Fresh, sticky resin is effective in reducing use of cavities by snakes (Jackson 1974, Rudolph et al. 1990b). The distance to the first branch above the cavity was only 0.6 m for the 2 cavities with SQEDs used by snakes. Distances to the nearest trees were 7.8 m and 13.2 m, respectively; therefore, it is unlikely that snakes reached the branches from other trees and approached the cavity from above. Snakes are capable of climbing across 30 cm wide pieces of flashing (J. Neal, pers. commun.) and the 2 snakes recorded may have climbed over the SQEDs. Alternatively, because irregularities in the shape of some trees often result in small spaces between the SQED and the bark, the snakes may have accessed the cavities by climbing behind the SQEDs. If snakes are a problem in a particular RCW population, snake excluders and traps might be considered (Richardson and Stockie 1995, Withgott et al. 1995).

All clusters remained inactive while the SQEDs were on the trees. Most of the clusters were inactive for 2 to 3 years prior to the onset of the study, indicating that the SQEDs were not the reason RCWs failed to occupy the sites. In Arkansas, RCWs readily reoccupy cavities with SQEDs, indicating that the birds will accept them (Montague 1995, Montague et al. 1995); however, in Arkansas many of the SQEDs were placed on recently active cavities (Montague et al. 1995). Perhaps RCWs use cavities with novel objects more readily if they have already used the cavities. The hypothesis requires further study. In this study nesting material left by flying squirrels or other species was not removed from cavities. Although cleaning cavities has not been necessary for reoccupation by RCWs at SRS (DeFazio et al. 1987) or in the

Piedmont of Georgia (pers. obs.), other investigators (Montague et al. 1995) have suggested that cavities should be cleaned to increase the likelihood of reoccupation by RCWs.

Management Implications

I showed that SQEDs are an effective method for keeping flying squirrels from using RCW cavities, and may be an alternative to continuous removal programs. Regardless, cavities should be monitored to ensure that SQEDs are not damaged or covered in sap and will remain an effective barrier to flying squirrels, particularly cavities with limbs or other trees short distances away. If flying squirrels continue to use cavities with SQEDs due to a branch close to the cavity, branch removal is recommended. Similarly, a nearby tree that improves flying squirrel accessibility should be removed if it does not contain a RCW cavity or is not a potential cavity tree.

SQEDs will only become an important management tool if they are accepted by RCWs. Few data are available on the response of RCWs to SQEDs, the effect of SQEDs on resin well production, and the effect of SQEDs on resin flow around the cavity. In Texas, some RCWs abandon cavities when SQEDs are placed on them (R. Conner, pers. commun.). In contrast, at least 14 cavities with SQEDs have been used for roosting by RCWs in Arkansas (Montague 1995); however, in the Arkansas population, SQEDs were only placed on inactive cavities within active clusters. Until more is known about the response of RCWs to SQEDs, it may be advisable to place SQEDs only on inactive cavities in active clusters, particularly those that have recently been abandoned due to occupation by flying squirrels. This will provide alternate cavities for RCWs that may be displaced from the cavities by flying squirrels or other species, as well as provide clean, unoccupied cavities for fledglings to use. Use of SQEDs in inactive recruitment clusters may be as important as use in active clusters. Occupation of cavities by flying squirrels in recruitment clusters limits the number of available cavities and may prevent red-cockaded woodpeckers from settling in the new site. Montague (1995) suggested that SQEDs may provide a visual attraction for RCWs and assist them in locating vacant cavity tree clusters; thus, SQEDs may be an important tool in population expansion as well as population stabilization.

Literature Cited

- Batson W. T., J. S. Angerman, and J. T. Jones. 1985. Flora of the Savannah River Plant: an inventory of the vascular plants on the Savannah River Plant, South Carolina. U.S. Dep. of Energy, Savannah River Plant, SRO-NERP- IS. 64pp.
- Conner, R. N. and D. C. Rudolph. 1995. Excavation dynamics and use patterns of red-cockaded woodpecker cavities: relationships with cooperative breeding. Pages 343–352 in D. L. Kulhavy, R. G. Hooper and R. Costa, eds. Red-cockaded woodpecker: recovery, ecology, and management. Ctr. Appl Stud. For., Stephen F. Austin State Univ. Nacogdoches, Texas.
- _____, _____, D. L. Kulhavy, and A. E. Snow. 1991. Causes of mortality of red-cockaded woodpecker cavity trees. *J. Wildl. Manage.* 55:531–537.

- Copeyon, C. K., J. R. Walters, and J. H. Carter III. 1991. Induction of red-cockaded woodpecker group formation by artificial cavity construction. *J. Wildl. Manage.* 55:549-556.
- DeFazio, J. T., Jr., M. A. Hunnicutt, M. R. Lennartz, G. L. Chapman, and J. A. Jackson. 1987. Red-cockaded woodpecker translocation experiments in South Carolina. *Proc. Annu. Conf. Southeast. Assoc. Fish and Wildl. Agencies* 41:311-317.
- Dennis, J. V. 1971. Species using red-cockaded woodpecker holes in northeastern South Carolina. *Bird-Banding* 42:79-87.
- Gaines, G. D., K. E. Franzreb, D. H. Allen, K. S. Laves, and W. L. Jarvis. 1995. Red-cockaded woodpecker management on the Savannah River Site: a management/research success story. Pages 81-88 in D. L. Kulhavy, R. G. Hooper and R. Costa, eds. *Red-cockaded woodpecker: recovery, ecology, and management*. *Ctr. Appl. Stud. For.*, Stephen F. Austin State Univ., Nacogdoches, Texas.
- Harlow, R. F. and M. R. Lennartz. 1983. Interspecific competition for red-cockaded woodpecker cavities during the nesting season in South Carolina. Pages 41-43 in D. A. Wood, ed. *Red-cockaded woodpecker symposium II*. *Fla. Game and Fresh Water Fish Comm.*, Tallahassee, Fla.
- Hepell, S. S., J. R. Walters, and L. B. Crowder. 1994. Evaluating management alternatives for red-cockaded woodpeckers: a modeling approach. *J. Wildl. Manage.* 58:479-487.
- Hooper, R. G. 1988. Longleaf pines used for cavities by red-cockaded woodpeckers. *J. Wildl. Manage.* 52:392-398.
- , A. F. Robinson, Jr., and J. A. Jackson. 1980. The red-cockaded woodpecker: notes on life history and management. *U.S. Dep. Agric., For. Serv. Gen. Tech. Rep. SA-GR9*. 8pp.
- Jackson, J. A. 1974. Gray rat snakes versus red-cockaded woodpeckers: predator-prey adaptations. *Auk* 91:342-347.
- . 1978. Competition for cavities and red-cockaded woodpecker management. Pages 103-112 in S. A. Temple, ed. *Endangered birds: management techniques for preserving threatened species*. *Univ. Wis. Press*, Madison, Wis.
- . 1990. Intercolony movements of red-cockaded woodpeckers in South Carolina. *J. Field Ornithol.* 61:149-155.
- Kappes, J. J., Jr. 1993. Interspecific interactions associated with red-cockaded woodpecker cavities at a north Florida site. *M.S. Thesis*. *Univ. of Fla. Gainesville*. 75pp.
- LaBranche, M. S. and J. R. Walters. 1994. Patterns of mortality in nests of red-cockaded woodpeckers in the Sandhills of southcentral North Carolina. *Wilson Bull.* 106:258-271.
- Lennartz, M. R. and D. G. Heekel. 1987. Population dynamics of a red-cockaded woodpecker population in Georgia piedmont loblolly pine habitat. Pages 48-55 in *Proc. Third Southeast. Nongame and Endangered Wildl. Symp.* *Ga. Dep. Nat. Resour.*, Athens, Ga.
- Ligon, J. D. 1970. Behavior and breeding biology of the red-cockaded woodpecker. *Auk* 87:255-278.
- Loeb, S. C. 1993. Use and selection of red-cockaded woodpecker cavities by southern flying squirrels. *J. Wildl. Manage.* 57:329-335.
- Montague, W. G. 1995. Cavity protection techniques for red-cockaded woodpeckers. *Proc. Ark. Acad. Sci.* 49:115-120.
- , J. C. Neal, J. E. Johnson, and D. A. James. 1995. Techniques for excluding southern flying squirrels from cavities of red-cockaded woodpeckers. Pages 401-409 in D. L. Kulhavy, R. G. Hooper and R. Costa, eds. *Red-cockaded woodpecker: recovery, ecology, and management*. *Ctr. App. Stud. For.*, Stephen F. Austin State Univ., Nacogdoches, Texas.
- Richardson, D. M. and J. M. Stockie. 1995. Response of a small red-cockaded woodpecker population to intensive management at Noxubee National Wildlife Refuge. Pages 98-105

- in D. L. Kulhavy, R. G. Hooper and R. Costa, eds. Red-cockaded woodpecker: recovery, ecology, and management. Ctr. Appl. Stud. For., Stephen F. Austin State Univ., Nacogdoches, Texas.
- Rudolph, D. C., R. N. Conner, and J. Turner. 1990a. Competition for red-cockaded woodpecker roost and nest cavities: effects of resin age and entrance diameter. *Wilson Bull.* 102:23-36.
- , H. Kyle, and R. N. Conner, 1990b. Red-cockaded woodpeckers vs rat snakes: the effectiveness of the resin barrier. *Wilson Bull.* 102: 14-22.
- Withgott, J. H., J. C. Neal, and W. G. Montague. 1995. A technique to deter rat snakes from climbing red-cockaded woodpecker cavity trees. Pages 394 -400 in D. L. Kulhavy, R. G. Hooper and R. Costa, eds. Red-cockaded woodpecker: recovery, ecology, and management. Ctr. Appl. Stud. For., Stephen F. Austin State Univ., Nacogdoches, Texas.
- Workman, S. W. and K. W. McLeod. 1990. Vegetation of the Savannah River Site: major community types. U.S. Dep. of Energy, Savannah River Site, SRO-NERP-19.137pp.

