

Effects of Elevated [CO₂] and Nitrogen Nutrition on Cytokinins in the Xylem Sap and Leaves of Cotton¹

Jean W.H. Yong, S. Chin Wong, D. Stuart Letham, Charles H. Hocart, and Graham D. Farquhar*

Environmental Biology Group (J.W.H.Y., S.C.W., G.D.F.) and Plant Cell Biology Group (D.S.L., C.H.H.), Research School of Biological Sciences, Australian National University, G.P.O. Box 475, Canberra, Australian Capital Territory 2601, Australia

We measured the level of xylem-derived cytokinins (CKs) entering a cotton leaf, and the CK levels in the same leaf, thus enabling xylem sap and foliar CKs to be compared concurrently. Although zeatin was the dominant CK in xylem sap, zeatin, dihydrozeatin, and N⁶-(2-isopentenyl) adenine were present in approximately equimolar levels in leaves. Elevated [CO₂] (EC) has an effect on the levels of cytokinins in sap and leaf tissues. This effect was modulated by the two levels of root nitrogen nutrition (2 and 12 mM nitrate). Growth enhancement (70%) in EC over plants in ambient [CO₂] (AC) was observed for both nitrogen nutrition treatments. Low-nitrogen leaves growing in EC exhibited photosynthetic acclimation, whereas there was no sign of photosynthetic acclimation in high-nitrogen grown leaves. Under these prevailing conditions, xylem sap and leaf tissues were obtained for CK analysis. Higher nitrogen nutrition increased the delivery per unit leaf area of CKs to the leaf at AC. EC caused a greater increase in CK delivery to the leaf at low nitrogen conditions (106%) than at high nitrogen conditions (17%). EC induced a significant increase in CK content in low-nitrogen leaves, whereas CK content in leaf tissues was similar for high-nitrogen leaves growing in AC and EC.

Plant growth is initiated at the meristems and consists of several processes that include cell division, cell expansion, and differentiation (Taylor, 1997). Growth in elevated [CO₂] (EC) changes plant structure through its effects on primary and secondary meristems of shoots and roots (for review, see Pritchard et al., 1999). A selected review of literature (Ranasinghe and Taylor, 1996; Kinsman et al., 1997; Pritchard et al., 1999; Masle, 2000) indicated that cell division, cell expansion, and cell patterning of plants in EC may be altered by increased substrate (Suc) availability and possibly by differential expression of genes involved in cell cycling and cell expansion.

It has been established that plant hormones including cytokinins (CKs), abscisic acid, auxins, and gibberellins are involved in controlling developmental events within apical meristems such as cell division, cell elongation, and protein synthesis. Evidence to date supports the pivotal role of CKs in regulating plant cell division, differentiation, cyclin genes (for review, see D'Agostino and Kieber, 1999), and cell elongation (Rayle et al., 1982). In plant cell division CKs are required at three stages of the cycle: G₁/S transition, G₂/M transition, and cytoplasmic division (John et al., 1993; Zhang et al., 1996; Laureys et al., 1999; Riou-Khamlichi et al., 1999).

CKs are predominantly root-sourced plant hormones as it is widely accepted that root tips are the major sites of CK biosynthesis. CK translocation from

the roots through the xylem to the aerial plant parts by the transpiration stream will control shoot development (Torrey, 1976; Letham and Palni, 1983; Letham, 1994). However, there are inconsistencies that weaken this hypothesis. There is evidence to show that meristematic plant tissues (other than root tips) are also capable of CK biosynthesis (Van Staden and Dimalla, 1981; Chen et al., 1985). If CKs are also synthesized in the shoots, root-sourced CKs may therefore be less important to leaf function. Nonetheless, it is more likely that root-sourced CKs play a greater role in mediating shoot growth in response to the conditions (e.g. root nutrition and temperature) in the root environment. Considering the enormous impact that growth in EC has on plant root systems (for review, see Rogers et al., 1996), it is possible that root CK production and supply through the xylem to the shoot may be altered in EC, and thereby may modify above ground growth (e.g. meristem size and leaf area) and developmental profile (e.g. apical dominance and branching).

In general, collection of bleeding xylem sap exuding from de-topped plants does give valuable information. However the composition of root-pressure bleeding sap is likely to be different from in vivo sap transported in an intact, transpiring plant, especially when bleeding sap is collected over an extended period. In addition, root-pressure sap is likely to have different solute content relative to sap in intact plants because phloem recirculation has ceased. The composition of the xylem sap is influenced by the return to the roots of solutes in the phloem (Schurr, 1998). An elegant approach that avoids this problem is the use of a root pressure chamber (Janes and Gee, 1973; Passioura, 1980; Munns and Passioura, 1984).

¹J.W.H.Y. was supported by the Australian National University, Nanyang Technological University, and the Tan Kah Kee Foundation (Singapore).

* Corresponding author; e-mail farquhar@rsbs.anu.edu.au; fax: 61-2-62494919.

The pneumatic pressure acting on the rooted soil is gradually increased and the plant water potential is elevated to an extent that the sap starts to exude from a small incision (e.g. leaf petiole) once the pressure balancing the tension created by transpiring leaves is reached. This technique has been employed by others seeking representative samples of the transpiration stream (Beck and Wagner, 1994; Else et al., 1995; Liang and Zhang, 1997; Jokhan et al., 1999).

The objective of this paper was to study the effects of EC on the growth of cotton (*Gossypium hirsutum* L. var Deltapine 90) plants and its associated levels of CKs in the xylem sap of leaf petioles and in leaf tissues. A better understanding of the effects of EC on CK levels and metabolism is important because growth changes in EC are probably initiated at the meristems where CKs have a crucial role in regulating cell proliferation. Special efforts were made to collect the xylem sap with minimal disruption to the whole plant transpiration. As nitrogen supply to the plant is also known to affect CK content (Samuelson et al., 1992; for review, see Jackson, 1993) and leaf growth (e.g. Sims et al., 1998b), the analysis was conducted on cotton plants growing at two levels of nitrogen nutrition in greenhouses under AC and EC.

RESULTS

Effects of [CO₂] and Nitrogen Nutrition on Whole Plant Growth and Photosynthesis

Cotton plants growing in 12 mM nitrate and under 720 ppm [CO₂] grew significantly more than those growing in AC (Table I). High-nitrogen plants accumulated 80% more structural dry mass (compare with 100% on a total dry mass basis) in EC, whereas those in low nitrogen treatments gained 60% increase in structural dry mass. High-nitrogen plants in EC produced 59% more leaf area than its control in AC, whereas low-nitrogen plants in EC gained 39% in leaf area. In particular, leaf 4, which was excised at the petiole for xylem sap collection (Fig. 1), of the high-

nitrogen plants was 43% larger in terms of leaf area in EC, whereas leaf 4 growing in low-nitrogen was only 26% larger than the corresponding control plants in AC. EC also increased the root mass for high-nitrogen- (120%) and low-nitrogen-grown (90%) cotton plants. At both nitrogen treatments, shoot-to-root ratios (based on structural dry mass) of cotton plants grown in EC were generally lower than those grown in AC (Table I). Analysis of leaf tissue nitrogen showed that the low-nitrogen-grown plants in EC exhibited a significant reduction (23% on a structural dry mass basis; 20% on an area basis) in nitrogen content (Table II). In contrast, high-nitrogen-grown cotton plants in EC showed a reduction of 7% in their leaf nitrogen content when expressed on a structural dry matter basis. Leaf nitrogen content was similar when expressed on a leaf area basis for the high-nitrogen-grown cotton plants in AC and EC. The amount of TNC in leaves was highest for cotton leaves in EC and at low-nitrogen nutrition. Significant differences in specific leaf weight (expressed on a structural dry mass basis) were observed and this indicated that growth in EC resulted in more structural dry mass per unit leaf area for both nitrogen treatments (14% for low nitrogen; 7% for high nitrogen). At high nitrogen nutrition, photosynthetic rates per unit leaf area of cotton plants grown at AC and enriched [CO₂] were not significantly different when measured at a common [CO₂] (Fig. 2, a and b). However, there was a significant difference in low-nitrogen-grown plants. At low nitrogen nutrition, photosynthetic rates of plants grown in enriched [CO₂] were about 20% lower than plants grown in AC when measured at a common [CO₂].

[CO₂] and Nitrogen Nutrition Effects on Xylem Sap CKs

We have used a simplified method for quantifying CKs in potentially active forms in the xylem sap and leaves. CK ribosides and nucleotides were converted

Table I. Plant mass (total dry mass and structural dry mass), leaf area, and shoot-to-root ratio of cotton plants (31–36 d after emergence)

Root structural dry mass was similar to the root total dry mass as the levels of total non-structural carbohydrates were very low when compared with leaves and stem tissues. Data are means ± SE (*n* = 3–5).

N Treatment	Growth CO ₂	Shoot Mass	Root Mass	Plant Mass	Shoot/Root	Leaf 4 Area	Total Leaf Area	
<i>mM</i>	<i>ppm</i>		<i>g/plant</i>			<i>cm²/leaf</i>	<i>cm²/plant</i>	
Total dry mass	2	360	6.10 ± 0.90 ^a	1.93 ± 0.14 ^a	8.0 ± 1.0 ^a	3.1 ± 0.3	120 ± 14 ^a	858 ± 125 ^a
		720	10.67 ± 0.89 ^a	3.74 ± 0.15 ^a	14.4 ± 1.0 ^a	2.8 ± 0.1	151 ± 10 ^a	1193 ± 77 ^a
12	360	12.60 ± 1.56 ^a	2.34 ± 0.37 ^a	14.9 ± 1.9 ^a	5.5 ± 0.2	167 ± 8 ^a	1905 ± 202 ^a	
	720	24.69 ± 2.47 ^a	5.06 ± 0.74 ^a	29.8 ± 3.2 ^a	5.1 ± 0.5	239 ± 18 ^a	3038 ± 189 ^a	
Structural dry mass	2	360	5.00 ± 0.80 ^a		7.0 ± 0.9 ^a	2.6 ± 0.2 ^a		
		720	7.80 ± 0.70 ^a		11.5 ± 0.9 ^a	2.1 ± 0.1 ^a		
12	360	11.50 ± 1.40 ^a		13.8 ± 1.8 ^a	5.0 ± 0.2			
	720	19.90 ± 2.40 ^a		24.5 ± 3.2 ^a	4.4 ± 0.5			

^a The difference between CO₂ treatments was significant (*P* < 0.05).

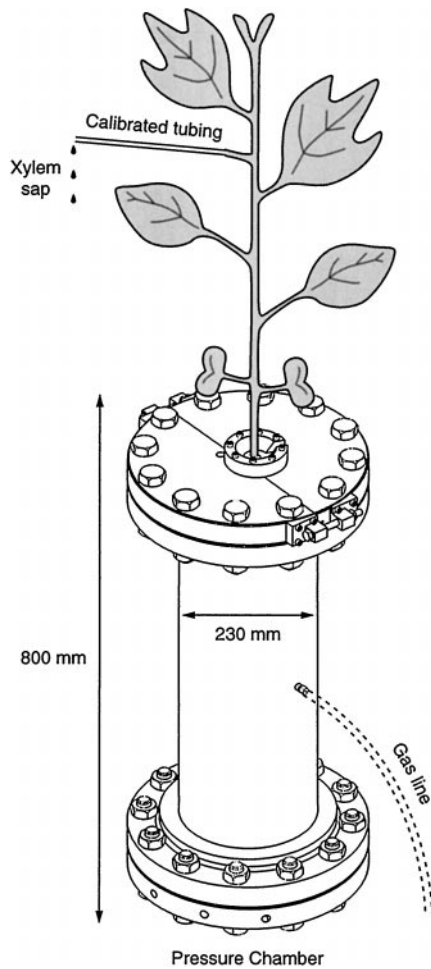

Figure 1. Simplified diagrammatic representation of the root pressure chamber with a cotton plant. The chamber was designed to use with a range of pot sizes and stem diameters. Sealing of the stem was achieved by using a conical shaped silicon rubber seal that is later compressed by a set of pressurizing plates. Note that pressure relief valves are not shown.

to bases, whereas the *O*-, 7-, and 9-glucoside linkages were not cleaved appreciably. Thus throughout this paper, zeatin (Z), dihydrozeatin (DZ), N⁶-(2-isopentenyl) adenine (iP), Z-*O*-glucoside (OGZ), and DZ-*O*-glucoside (OGDZ) levels refer to the total content of each compound (base) in free, riboside, and nucleotide forms. Z, DZ, and iP (free and released) were detected in cotton xylem sap for all treatments

(Table III). Z was the main CK base in the xylem sap and accounted for 90% to 96% of the total CK bases. The relative proportion of the three bases remained similar in nitrogen and [CO₂] treatments. EC increased the concentration of CKs in the sap at low nitrogen (144%) and high nitrogen (35%) treatments. Similarly, EC increased the delivery (on the basis of delivery rates, fmol s⁻¹) of CKs to leaf 4 at low nitrogen (158%) and high nitrogen (70%) treatments. EC increased the delivery of CKs (delivery per unit leaf area, fmol m⁻² s⁻¹) from the roots to leaf 4 at low nitrogen (106%, on a leaf area basis) and high nitrogen treatments (17%, on a leaf area basis; Fig. 3). At AC, low-nitrogen leaves received 67% less CK delivery (per unit leaf area) than the high-nitrogen leaves, whereas low-nitrogen and high-nitrogen leaves have similar levels of CK delivery at EC. EC has no significant effect on the delivery per unit leaf area of CK *O*-glucosides from the roots to leaf 4 at low nitrogen and high nitrogen treatments (Fig. 4). OGDZ was the main *O*-glucoside detected in the sap and it was 2- to 7-fold more than the OGZ across all the treatments (data not shown). If we naively assume that all leaves received similar level of xylem-derived CKs as that of leaf 4, then the whole plant CK delivery per unit root dry mass can be estimated (Fig. 5). EC had little effect on the whole-plant CK delivery per unit root dry mass for low-nitrogen- and high-nitrogen-grown cotton plants. High-nitrogen-grown cotton plants had a 100% increase in the whole plant CK delivery per unit root dry mass over low-nitrogen-grown plants in AC and EC.

[CO₂] and Nitrogen Nutrition Effects on Leaf CK Content

Z, DZ, and iP (free and released) were detected in leaf tissues for all treatments (Table IV). The patterns of CKs in leaf tissues across treatments were also similar when expressed on either a dry mass basis or a structural dry mass basis (data not shown). The relative proportion of the three CK bases within each treatment changed in response to nitrogen and [CO₂] treatments. For example, high-nitrogen cotton leaves in EC contained proportionally less Z (39% of CK bases) than the high-nitrogen AC-grown cotton plants (65%). At AC, low- and high-nitrogen leaves had similar levels of Z (Table IV). In contrast, the

Table II. Leaf nitrogen content, total non-structural carbohydrates (TNC) and specific leaf weight of cotton plants (31–36 d after emergence)

Leaf nitrogen content (mg g⁻¹) and specific leaf weight (g m⁻²) were calculated using structural dry mass. Data are means ± SE (n = 3–5).

N Treatment	Growth CO ₂	Nitrogen	Leaf TNC	Specific Leaf Weight	
mm	ppm	mg/g	mmol/m ²	mg/g	
				g/m ²	
2	360	40.0 ± 1.0 ^a	94.7 ± 5.0 ^a	236 ± 19 ^a	33.1 ± 0.7 ^a
	720	30.8 ± 1.4 ^a	75.7 ± 4.4 ^a	316 ± 32 ^a	37.8 ± 0.9 ^a
12	360	54.1 ± 1.4 ^a	140.4 ± 3.5	116 ± 17 ^a	36.4 ± 0.2 ^a
	720	50.3 ± 1.2 ^a	139.7 ± 1.6	203 ± 21 ^a	38.9 ± 0.8 ^a

^a The difference between CO₂ treatments was significant (*P* < 0.05).

Figure 2. A, Light-saturated photosynthesis of leaves measured at 360 ppm [CO₂] for low-nitrogen and high-nitrogen cotton plants growing in AC and EC; B, light-saturated photosynthesis of leaves measured at 720 ppm [CO₂] for low-nitrogen and high-nitrogen cotton plants growing in AC and EC. Data were derived from three to five plants, means ± SE. All measurements were made in the greenhouse where the leaf temperature was 31°C to 35°C and vapor pressure difference between leaf and air was 1.2 to 1.8 kPa. The response of assimilation to intercellular [CO₂] was measured at photosynthetic photon flux density of 1,400 μmol m⁻² s⁻¹ that was sufficient to saturate photosynthesis. White bars, AC-grown plants; hatched bars, EC-grown plants.

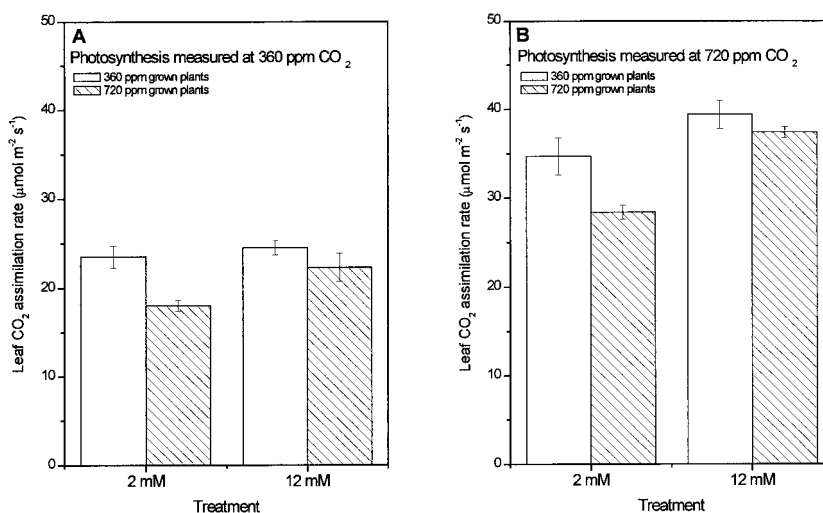

high-nitrogen leaves in EC had a 500% decrease in Z levels (on a leaf area basis and a fresh mass basis). The levels for iP in leaves did not change appreciably for all treatments. There was a significant increase (164% on a leaf area basis; 126% on a fresh mass basis) of CKs in low-nitrogen leaves in EC when compared with the control plants in AC (Fig. 6, a and c). The CK content (per unit leaf area and per unit fresh mass) of high-nitrogen-grown plants in EC did not differ significantly from those growing in AC. Generally, EC has no effect on the CK *O*-glucoside content (per unit leaf area and per unit fresh mass) of leaf 4 in low and high nitrogen treatments (Fig. 6, b and d). OGDZ and OGZ were the two *O*-glucosides detected in the leaves and they remained in similar proportions across all the treatments (data not shown).

DISCUSSION

The occurrence of a CK response to EC was investigated in cotton plants growing in two levels of nitrogen nutrition. Growth responses obtained in this experiment were similar to those found in previous experiments using a different cotton cultivar, Deltapine 16 (Wong, 1990). The increase in cotton plant growth in EC was generally attributed to the increase in the rate of photosynthesis per unit leaf area. Under these prevailing conditions, xylem sap and leaf tissues were obtained for CK analysis. During the collection of xylem sap, we have maintained the transpiration rate of the whole plant similar to that before the excision of the leaf. As the excised leaf was only about 8% to 14% of the total leaf area for the plant, a 10% error in the control of xylem sap flow at the cut end of the petiole would result in not more than 2% change in the transpiration rate of the whole plant grown at high nitrogen nutrition. This was because variations in stomatal conductance of various leaves of cotton plant grown at high nitrogen nutrition were

small (data not shown). For low-nitrogen-grown cotton plants, the error can be slightly larger. Our estimate is that the error represented no more than a 4% change in the whole-plant transpiration rate.

Our ability to collect xylem sap with solutes identical to that entering the intact leaves coupled with the improved CK assay method for cotton xylem sap and tissues has provided new insights into CK metabolism. Thus the precise information on the level and identity of xylem-derived CKs entering a cotton leaf (Table III) coupled with the data on CK levels in this leaf (Table IV) enable xylem sap and foliar CKs to be compared concurrently for the first time. A similarity in relative levels of the different CK types might be expected between xylem sap and leaf, but was not observed (compare with Tables III and IV). Thus relative to Z (the predominant CK), DZ and iP were minor CKs in the xylem sap received by leaf 4. However, all three CK types were nearly equally prominent in the leaves (Table IV). This suggests that DZ and iP were conserved relative to Z in the leaves and/or that Z-type CKs may be converted to DZ. Conservation of the DZ-type CK can be accounted for by its stability to CK oxidase, which readily degrades Z. However, conservation of iP, which is degraded by CK oxidase and trans-hydroxylated to yield Z, is difficult to rationalize. The results emphasize the importance of CK metabolism in determining the CK status of leaves. Information of the type mentioned above derived from our xylem sap collection method should complement the commonly used approach to study CK metabolism based on radiolabeled compounds and excised organs.

[CO₂] and Nitrogen Nutrition Effects on Xylem Sap CKs

The CKs in the xylem sap of cotton plants grown in this experiment were predominantly (more than 90%) the trans-Z type. However, storage forms of

Table III. Xylem sap flow rate, cytokinin concentrations ($\mu\text{mol m}^{-3}$), and delivery rates (fmol s^{-1}) of the sap collected at the petiole of leaf 4 of cotton plants (31–36 d after emergence)

N Treatment	mm	Growth CO ₂	Sap Flow		Z			DZ			iP			Total Cytokinin Bases		
			mm ³ /s	mm ³ /s	$\mu\text{mol/m}^3$	fmol/s	fmol/s	$\mu\text{mol/m}^3$	fmol/s	fmol/s	$\mu\text{mol/m}^3$	fmol/s	fmol/s	$\mu\text{mol/m}^3$	fmol/s	fmol/s
2	360	2.06 ± 0.16	0.85 ± 0.22 ^a	1.74 ± 0.48 ^a	0.05 ± 0.03 ^a	0.11 ± 0.06 ^a	0.02 ± 0.01 ^a	0.05 ± 0.03 ^a	0.9 ± 0.2 ^a	1.9 ± 0.5 ^a						
	720	2.28 ± 0.11	2.09 ± 0.28 ^a	4.71 ± 0.60 ^a	0 ^a	0 ^a	0.08 ± 0.01 ^a	0.19 ± 0.03 ^a	2.2 ± 0.3 ^a	4.9 ± 0.6 ^a						
12	360	2.65 ± 0.16 ^a	1.52 ± 0.20	3.99 ± 0.57 ^a	0.07 ± 0.03 ^a	0.18 ± 0.06 ^a	0.10 ± 0.02 ^a	0.26 ± 0.06	1.7 ± 0.2	4.4 ± 0.6 ^a						
	720	3.41 ± 0.48 ^a	2.03 ± 0.43	6.76 ± 1.18 ^a	0.18 ± 0.06 ^a	0.62 ± 0.19 ^a	0.04 ± 0.01 ^a	0.13 ± 0.07	2.3 ± 0.5	7.5 ± 1.4 ^a						

^a The difference between CO₂ treatments was significant ($P < 0.05$).

The value of each cytokinin base represented the total in free, riboside, and nucleotide forms. Data are means ± SE ($n = 3-4$). Cytokinin delivery rates to leaf 4 were calculated by multiplying the concentration by a sap flow rate. During xylem sap collection, sap flow rate was maintained at the level of transpiration (mmol s^{-1}) of the leaf prior to its excision. During the sap collection period, transpiration of an adjacent leaf (leaf 5) was continuously monitored to ensure that the transpirational flux of the whole plant was not significantly altered.

CKs (OGZ and OGDZ) were also detected in the sap. Xylem sap collected from the petioles of high-nitrogen-grown cotton contained higher levels of CKs than those grown in low nitrogen in AC. This observation was also noted for stinging nettle (*Urtica dioica* L.) plants grown in two nitrogen nutrition (3 and 15 mM nitrate) and where xylem sap was collected from de-topped plants using a pressure chamber in AC (Beck and Wagner, 1994). An earlier study by the same research group using the same plant species and similar growth conditions reported no effect of nitrogen nutrition (3, 15, and 22 mM nitrate) on CKs collected from de-topped plants using natural root pressure (Fusseder et al., 1988). These examples highlight the importance of maintaining the normal whole-plant transpiration flux during sap collection.

Most of the previous studies of nitrogen effects on xylem sap CKs (Sattelmacher and Marschner, 1978; Salama and Wareing, 1979) were based on root pressure exudates collected after shoot excision. Usually, a low nitrogen supply resulted in a reduced CK level in the sap. These observations were confirmed by the present study with cotton plants grown in AC. We have established for the first time that increased nitrogen supply increases the actual delivery rate per unit leaf area of CKs to the leaf in AC. In EC, high-nitrogen- and low-nitrogen-grown leaves received similar levels (delivery rate per unit leaf area) of xylem CKs (Fig. 3). This observation implies that CK production was stimulated more in the low-nitrogen-grown cotton plants than in high-nitrogen-grown plants under EC. Furthermore, this could suggest that CK supply to the leaf is already physiologically

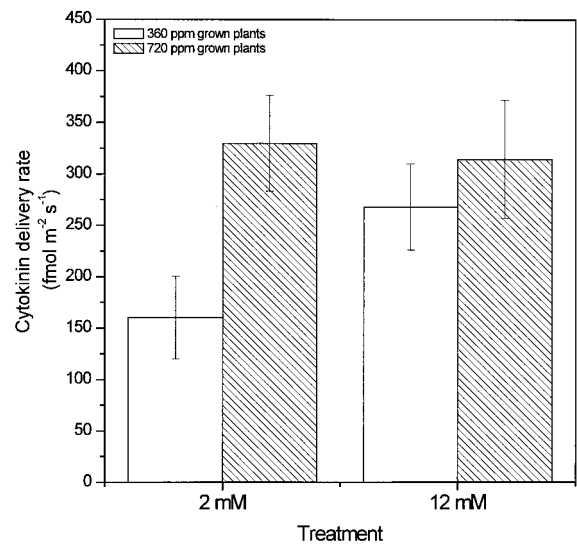

Figure 3. Xylem sap CK delivery rate per unit leaf area ($\text{fmol m}^{-2} \text{s}^{-1}$) in the petiole of cotton leaf 4. Data were derived from three to four cotton plants, means ± SE. CKs [zeatin, dihydrozeatin, and N⁶-(2-isopentenyl) adenine] were measured using scintillation proximity immunoassay. White bars, AC-grown plants; hatched bars, EC-grown plants.

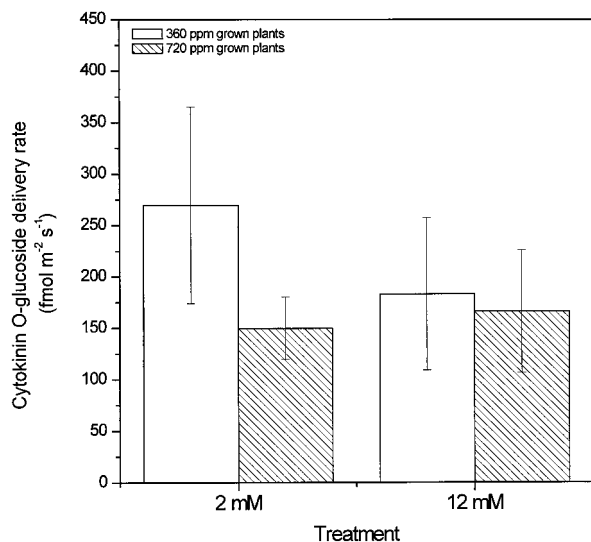

Figure 4. Xylem sap cytokinin *O*-glucoside delivery rate per unit leaf area ($\text{fmol m}^{-2} \text{s}^{-1}$) in the petiole of cotton leaf 4. Data were derived from three to four cotton plants, means \pm SE. CK *O*-glucosides (zeatin *O*-glucosides and dihydrozeatin *O*-glucosides) were measured using scintillation proximity immunoassay. White bars, AC-grown plants; hatched bars, EC-grown plants.

optimized in high nitrogen nutrition conditions, and that doubling of $[\text{CO}_2]$ only stimulates a slight increase in the CK delivery (Fig. 3). We cannot offer a physiological explanation for this phenomenon as the mechanism by which the nitrogen supply to the root is translated into a CK signal remains unclear (for review, see Stitt, 1999). Nonetheless, some progress was made in this area when a transcript for a CK-induced protein (pZmCip1) was isolated in maize leaves (Sakakibara et al., 1998). Sakakibara and coworkers (1998) showed that the addition of either nitrate or ammonium ions to the roots of intact maize plants led to an induction of phosphoenolpyruvate carboxylase (PEPc) in leaves, whereas the addition of nitrogen sources to the leaves did not. Induction of PEPc in the whole plant was associated with increased levels of CKs in the xylem sap and an increase of the transcript for the CK induced protein. Furthermore, the increase in PEPc and pZmCip1 transcripts could be mimicked by feeding exogenous CKs to detached leaves. Their results clearly implicated the synthesis of CKs in the roots in response to nitrogen ions. Nitrogen nutrition also markedly affects the fate of individual CK, which enters the cotton leaf. Thus supply of high nitrogen to EC grown plants did not appreciably change the Z delivery into leaf 4 (Fig. 3, where Z constituted 90% of the CK delivery rate per unit area), but did markedly lower (approximately 500%) the Z level in leaf 4 (Table IV). Hence, the rate of Z catabolism in the leaf appears to be greater in high-nitrogen- and EC-grown plants. The level of iP in leaf 4, unlike that of Z, changes little in response to growth $[\text{CO}_2]$. If CK metabolism is coupled to CK action as has been suggested, the sta-

bility of iP may result from a lack of involvement in mediation of $[\text{CO}_2]$ -induced changes.

Our data (Figs. 3 and 6) can also be used to calculate an "apparent CK turnover time" in cotton leaves by dividing the leaf CK pool size (Fig. 6) by the CK delivery into the leaf (Fig. 3). The results for low-nitrogen plants are approximately 6 and 8 h at 360 and 720 ppm respectively, and for high-nitrogen plants, 3 and 2 h at 360 and 720 ppm respectively. Higher nitrogen nutrition appears to increase the CK turnover rate. However, this simplistic analysis still lacks several considerations such as the potential contribution of free CKs from CK *O*-glucosides, rate of glucosylation, diurnal effects on CK export from the roots, and biochemical interconversion between the different CKs. A detailed study to describe CK turnover in leaves will be presented later (J.W.H. Yong, unpublished data). At the whole-plant level, higher nitrogen nutrition increases the whole-plant CK delivery per unit root dry mass at AC and EC (Fig. 5). It is interesting that shoot exposure to either AC or EC appears to have little effect on the whole-plant CK delivery per unit root dry mass. This calculation was based on the assumption that all leaves received similar level of CKs as that of leaf 4. As a note of caution, expressing the whole-plant CK delivery per unit root dry mass basis may not be a good reflection of the physiological role of roots in relation to CK production as a large proportion of the root system consists of non-living structural tissues.

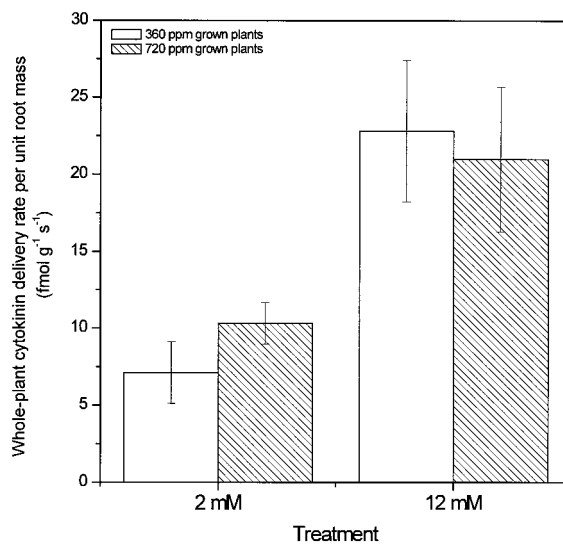

Figure 5. Whole-plant CK delivery rate per unit root mass ($\text{fmol g}^{-1} \text{s}^{-1}$) of cotton plants growing in AC and EC. The whole-plant CK [zeatin, dihydrozeatin, and N^6 -(2-isopentenyl) adenine] delivery per unit root dry mass was based on the assumption that all leaves received similar level of CKs from the roots as that of leaf 4. Data were derived from three to four cotton plants, means \pm SE. CKs were measured using scintillation proximity immunoassay. White bars, AC-grown plants; hatched bars, EC-grown plants.

Table IV. Leaf cytokinin content expressed on an area basis (nmol m⁻²) and fresh mass basis (pmol g⁻¹) in leaf 4 of cotton plants (31–36 d after emergence)

The value of each cytokinin base represented the total in free, riboside, and nucleotide forms. Data are means ± SE (n = 3–4).

N Treatment	Growth CO ₂		Z		DZ		iP	
	mM	ppm	nmol/m ²	pmol/g	nmol/m ²	pmol/g	nmol/m ²	pmol/g
2	360		1.62 ± 0.45 ^a	7.10 ± 1.93 ^a	0.83 ± 0.17 ^a	3.65 ± 0.69 ^a	1.12 ± 0.21	4.92 ± 0.83
	720		4.92 ± 1.88 ^a	18.43 ± 6.93 ^a	2.98 ± 1.19 ^a	11.20 ± 4.49 ^a	1.51 ± 0.45	5.72 ± 1.74
12	360		2.01 ± 0.14 ^a	7.58 ± 0.63 ^a	0.36 ± 0.08	1.33 ± 0.28	0.70 ± 0.24	2.70 ± 1.01
	720		0.84 ± 0.24 ^a	2.87 ± 0.75 ^a	0.60 ± 0.38	2.07 ± 1.33	0.73 ± 0.59	2.54 ± 2.10

^a The difference between CO₂ treatments was significant (*P* < 0.05).

[CO₂] Effects on Leaf Growth by Altering CK Delivery to the Leaf

The remarkable outcome of studies with labeled CKs was the rapidity of their metabolism (Nooden and Letham, 1993). For example, ³H-ZR fed through the xylem was quickly metabolized to other compounds (approximately 80% within 1 h) and almost all (more than 95%) of the parent compound was

metabolized within the 2nd h of incubation. Because of the rapid metabolism of xylem-derived CKs, there will be little or no accumulation of these CKs in active forms in the leaves. A decline in xylem-derived CKs should be rapidly sensed by the leaf. Hence, the root-leaf CK signal should be a very effective one. Our data indicated that leaf 4 received more xylem-derived CKs (delivery rate per unit area)

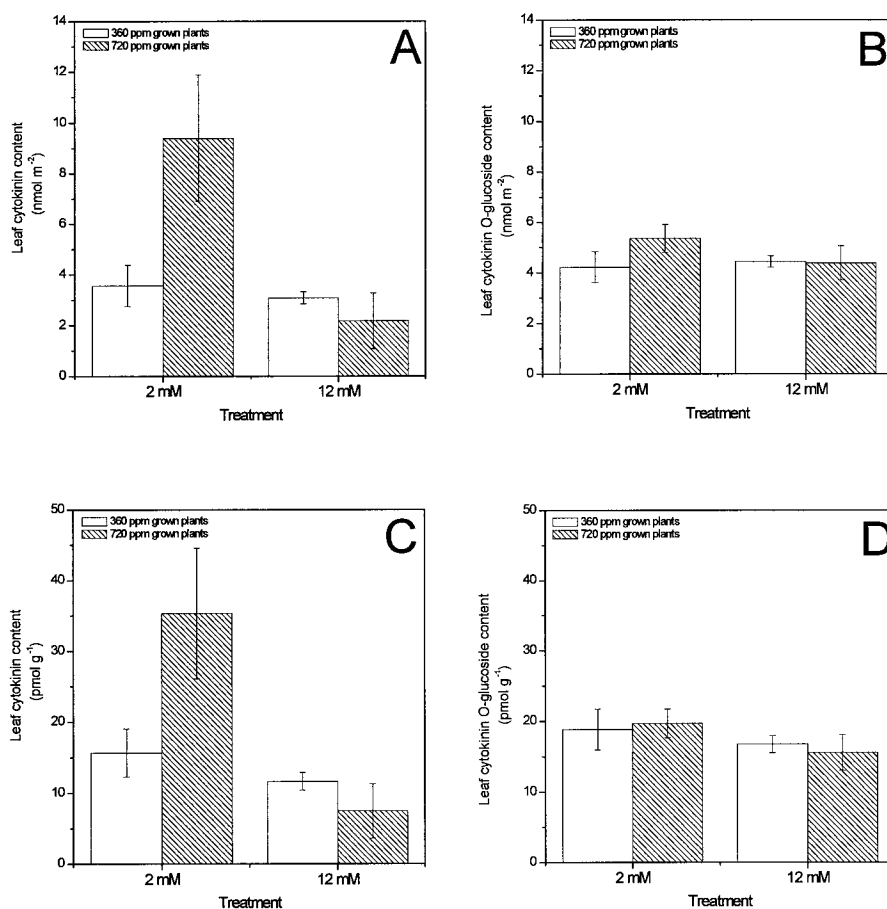

Figure 6. Leaf CK content in leaf 4 of cotton plants growing in AC and EC. A, Leaf CK [zeatin, dihydrozeatin, and N⁶-(2-isopentenyl) adenine] content expressed on a leaf area basis (nmol m⁻²); B, leaf cytokinin O-glucoside (zeatin O-glucosides and dihydrozeatin O-glucosides) content expressed on a leaf area basis (nmol m⁻²); C, leaf CK [zeatin, dihydrozeatin, and N⁶-(2-isopentenyl) adenine] content expressed on a fresh mass basis (pmol g⁻¹); D, leaf CK O-glucoside (zeatin O-glucosides and dihydrozeatin O-glucosides) content expressed on a fresh mass basis (pmol g⁻¹). Data were derived from three to four cotton plants, means ± SE. CKs were measured using scintillation proximity immunoassay. White bars, AC-grown plants; hatched bars, EC-grown plants.

in response to EC (Fig. 3). The magnitude of these differences in CK delivery between ambient [CO_2] (AC)- and EC-grown leaves was high in low-nitrogen conditions and lower in high-nitrogen conditions. There was, however, no direct and simple proportional link between the percentage increase in delivery of CKs arriving at the leaf in EC over AC, and the resultant increase in leaf area. For low-nitrogen-grown plants, we observed a 26% increase in area of leaf 4 at EC, and this was accompanied by a 106% (on an area basis) increase in CK delivery. On a whole-plant basis, low-nitrogen leaves were 14% "thicker" (greater structural dry mass per unit leaf area). In high-nitrogen plants, there was an increase of 43% in area of leaf 4 and a 17% (on an area basis) increase in CK delivery in response to EC. On the whole-plant basis, high-nitrogen leaves were 7% "thicker" (greater structural dry mass per unit leaf area).

The lack of a simple proportional link between leaf area and its CK fluxes in response to EC may reflect the complexity of CK metabolism and growth regulation at the cellular/molecular level. Also, part of the original xylem-derived CK signal arriving at the cotton leaf may be modified by foliar compartmentation within the leaf tissues. Sims and coworkers (1998b) encountered similar difficulties in their attempt to correlate leaf area and thickness with leaf expansion rate in EC. They suggested that EC probably had independent effects on leaf expansion rates and thickening of soybean leaves across a series of light and nitrogen gradients. Nonetheless, in the present study cotton leaves growing in two different nitrogen nutritions under EC received higher levels of CKs, although the function and fate of these xylem-derived CKs remained unclear. However, as discussed in the earlier section, a large proportion must have been catabolized. We also do not rule out the involvement of other hormones (e.g. gibberellins and abscisic acid) in mediating growth responses to EC.

Evidence drawn from cellular experiments further supports the role of CKs in mediating growth increases during exposure to EC, although none of these three studies mentioned here made direct measurements of CKs. Kinsman et al. (1997) provided evidence that exposure to EC stimulates primary growth of *Dactylus glomerata* shoots by increasing the proportion of rapidly dividing cells and shortening the cell cycle duration in shoot apices. The authors proposed that increased Suc availability in meristems during exposure to EC might have increased the proportion of rapidly dividing cells by stimulating cyclin activity. It is noteworthy that cyclins and cyclin-dependent kinases are proteins that regulate cell cycle and these proteins are under the influence of CKs (for review, see D'Agostino and Kieber, 1999). Ranasinghe and Taylor (1996) showed, using the primary leaves of *Phaseolus vulgaris*, that cell production and expansion were stimulated by EC. Increased leaf

cell expansion is an important mechanism for enhanced leaf growth in EC, whereas the importance of increased leaf cell production in EC remains unknown. Similar observations were also made for the monocot, wheat (Masle, 2000). Masle observed a strong link between [CO_2] effects on cell division and expansion process in wheat. This link was substantiated by a good correlation between the spatial patterns of local rates of cell partitioning and elongation. A consistent effect of EC treatment was to reduce the time interval between successive cell divisions in expanding wheat leaves. It is therefore conceivable that the increased cell proliferation and cell expansion observed in *P. vulgaris* and wheat leaves, and the increase in primary growth of *D. glomerata* shoot apices, in EC was mediated by a greater delivery of CKs arriving at the shoot tissues from the roots. Since CO_2 is the substrate for photosynthesis, it is important to stress that the primary effect of EC on plant growth is the enhancement of photosynthesis.

All the above observations on increased cell division and cell expansion at EC can only occur when carbon and nitrogen are not limiting. As the xylem stream may only reach the transpiring plant parts and not the apical shoot tips and other major sites of cell division, the phloem may also be involved in the delivery of CKs at some stage in mediating growth regulation (Ziegler, 1975; Vonk, 1979; Komor et al., 1993; Lejeune et al., 1994). Future work that aims to resolve this question should involve xylem and phloem estimation of CK fluxes, cellular growth analysis (kinematic, anatomical, and anisotropy), and carbon translocation studies.

Is Photosynthetic Acclimation of Leaves at EC Influenced by the Levels of CKs?

Photosynthetic acclimation of leaves at EC is a complex and unresolved phenomenon (for review, see Sage, 1994; Drake et al., 1997; Stitt and Krapp, 1999), but predominantly modulated by sink limitation (Arp, 1991; Stitt, 1991), nitrogen limitation (Stitt and Krapp, 1999), and leaf age (Miller et al., 1997). It is widely accepted that the reduction of photosynthetic capacity in many plants grown in EC is attributed to the feedback effect of leaf carbohydrates on gene expression. However, recent data obtained by Sims and coworkers (1998a) who exposed soybean leaflets to a [CO_2] differing from that around the rest of the plant indicated that leaf carbohydrate may not be the crucial factor in reducing foliar photosynthetic capacity in EC. They proposed that mechanisms by which sink strength could alter leaf physiology and operate independently of changes in carbohydrate accumulation are likely to influence photosynthetic acclimation in EC. In his extensive review of the phenomenon of photosynthetic acclimation from a gas-exchange perspective, Sage (1994) speculated that the involvement of hormone-mediated signaling

from roots at EC was a potential control point, which had remained largely unstudied. Our high-nitrogen-grown cotton leaves have similar levels of CKs in AC and EC. In contrast, there was a significant accumulation of CKs in the low-nitrogen leaves in EC. It is noteworthy that the levels of CKs in the low-nitrogen leaves in AC were similar to those of the high-nitrogen-grown cotton leaves in AC and EC. Similar levels of leaf CK content (per unit fresh mass) have been reported for mature leaves of stinging nettle growing in two different nitrogen nutrition (3 and 15 mM nitrate) at AC (Wagner and Beck, 1993). There was also a concomitant decrease in light-saturated photosynthesis of low-nitrogen cotton leaves growing in EC, when measured at 360 and 720 ppm [CO₂] in comparison with the control plants. In addition, these low-nitrogen leaves in EC have a high TNC content (Table II). With limitation to growth processes brought about by nitrogen, a "physiologically unbalanced" condition induced in EC may be manifested in part by the supra-optimal levels of active CKs in the leaves. We therefore postulate that these leaves under the prevailing low-nitrogen nutrition and EC environment were unable to fully utilize the xylem-derived CKs for physiological function. It is possible that an increase of active CK bases exceeded a threshold level that is unfavorable for photosynthetic activity in its broadest sense (e.g. NADH-dependent hydroxypyruvate reductase proteins are down-regulated by supra-optimal levels of iP, iP riboside, and ZR [Wingler et al., 1998]).

Studies with transgenic plants expressing a CK biosynthesis gene also show that photosynthetic acclimation of leaves to [CO₂] could be associated with hormonal imbalance. These studies could be interpreted in terms of threshold levels for CKs in leaves, which when exceeded can lead to pronounced physiological effects (for review, see Synková et al., 1997). Generally, a small increase in endogenous CKs is associated with slight, often positive effects on photosynthetic characteristics (e.g. Čatský et al., 1993). At high CK levels, most of the foliar photosynthetic activities are smaller. If we assume that the high-nitrogen-grown cotton leaves in AC and EC maintained optimal levels of CKs in the leaves for physiological function, it is possible that the low-nitrogen leaves in EC exceeded the optimal levels of CKs. This may lead to a decline in Rubisco (the major plant protein) content that eventually causes a decline in leaf nitrogen content and photosynthesis (Table II; Fig. 2). This view is supported by the observation that gene promoter activity of the small subunit of Rubisco was reduced by supra-optimal levels of CKs (Gaudino and Pikaard, 1997). Of course it is also possible that CKs accumulated because they could not be utilized and that foliar photosynthetic capacity was lower for some unrelated reason. Clearly more work needs to be done to clarify the involvement of

CKs, and possibly the other plant hormones in regulating photosynthetic acclimation at EC.

In conclusion, the data presented here demonstrated that higher nitrogen nutrition increased the delivery (per unit leaf area) of CKs from the roots through the xylem to the cotton leaf at AC. EC caused a greater increase in CK delivery to the cotton leaf at low nitrogen conditions than at high nitrogen conditions. CK content (per unit leaf area and per unit fresh mass) in leaf tissues was similar for high-nitrogen leaves growing in AC and EC. A significant increase in CK content in low-nitrogen leaves was induced by EC. The increased levels of xylem-derived CKs arriving at the leaf tissues growing in EC are likely to provide the necessary hormonal cues to alter leaf growth and development at the cellular/molecular level. The ability of leaf tissue to utilize the increased delivery of CKs in EC may be an important determinant in understanding photosynthetic acclimation of leaves in EC.

MATERIALS AND METHODS

Growth Conditions

Seeds of cotton (*Gossypium hirsutum* L. var Deltapine 90) were sown in 4.5-L polyvinyl chloride pots containing sterilized soil mixture (3 parts sand:1 part loam). Uniform seedlings were selected during thinning from six to one per pot after germination. Experiments were carried out on 31- to 36-d-old plants with seven to 10 leaves. The two adjacent greenhouses were well-ventilated and matched for temperature (30°C ± 2°C day, 20°C ± 2°C night) and relative humidity (45% ± 10% day, 70% ± 10% night). The [CO₂] of one greenhouse (ambient) was run at 360 ± 15 ppm, whereas the other greenhouse was run at an EC of 720 ± 30 ppm. The plants were grown under full sunlight between late summer and early autumn, the midday irradiance being 1,600 μmol m⁻² s⁻¹. The daylength decreased slowly over the duration of the experiment (February through April 1999) from 13 to 11 h according to the seasonal variation existing in Canberra, Australia. The potting mixture in each pot was flushed daily in the early morning with 1 L of Hewitt's nitrate nutrient (Hewitt and Smith, 1975), consisting of 4 mM K⁺, 4 mM Ca²⁺, 1.5 mM Mg²⁺, and 1.33 mM H₂PO₄⁻ with balancing SO₄²⁻ and Cl⁻ anions and micronutrients. There were two nitrate concentrations: 12 and 2 mM. Plants were watered in the late afternoon to compensate for the water loss due to transpiration.

Leaf Gas Exchange Measurements

Leaf gas exchange was measured using an open system gas exchange apparatus (LI-6400, LI-COR, Lincoln, NE) equipped with the standard leaf chamber, light-emitting diode light source, and the [CO₂] injector system for control of [CO₂]. The response of assimilation to intercellular [CO₂] was measured at photosynthetic photon flux density of 1,400 μmol m⁻² s⁻¹ that was sufficient to saturate photosynthesis. All measurements were made in the green-

house where the leaf temperature was 31°C to 35°C and vapor pressure difference between leaf and air was 1.2 and 1.8 kPa.

Xylem Sap Collection

We designed and built a root pressure chamber with a split lid to house a polyvinyl chloride pot (maximum dimensions of a 160-mm diameter by a 600-mm length; Fig. 1). The xylem water potential of a cotton plant whose roots are enclosed in the chamber can be altered by varying pneumatic pressure. The through flow rate of the pressurizing gas was about 1 L per min. The partial pressure of O₂ of the pressurizing gas was maintained at 21 kPa by mixing O₂ with N₂. This was achieved by using computer-controlled motorized needle valves. Each sap collection exercise took place on a cloudless day within the greenhouses (360 or 720 ppm CO₂) where the plants were growing, to minimize changes to the whole-plant transpiration rates.

Transpiration rate of the youngest fully expanded leaf (usually leaf 4, counting after the cotyledons) was calculated using the transpiration rate per unit leaf area and the leaf area. After sealing the pot into the pressure chamber, the leaf 4 was excised. The pneumatic pressure was raised gradually until it reached slightly above zero water potential such that the rate of sap collection was equal to the transpiration rate, before excision, of leaf 4. Xylem sap flowing out of the petiole was monitored by measuring the speed of the sap flowing through small-diameter polyethylene tubing.

We also monitored the transpiration rate and the other gas exchange parameters of an adjacent leaf (leaf 5, slightly younger than leaf 4) before excision of the target leaf and throughout the sap collection period. This was done to ensure that there was no significant change to the whole-plant transpiration rate during the sap collection period.

Preliminary studies have shown that leaf 5 had similar gas exchange characteristics to leaf 4. The removal of leaf 4 only resulted in the loss of 8% to 14% of the total leaf area. The first approximately 200 μL or more of sap was discarded to avoid contamination by cut cells and each sap collection exercise took about 2 to 4 h (between 7 AM and 12 PM) to minimize distortion to sap flow and wound-induced contamination (Else et al., 1994; Jokhan et al., 1999). A possible, but unlikely, contamination by phloem sap was checked by analyzing for Suc. The results were negligible. Sap for solute analysis was collected in glass vials (kept at 0°C in an ice bath) throughout the collection period. Immediately after collection, sap samples were frozen and stored at -20°C. Leaf area and fresh weight were measured immediately after excision and the leaf was wrapped in aluminum foil and immersed in liquid nitrogen. Leaf area was measured with a leaf area meter (LI-3000, LI-COR). Leaf tissues were later stored in -80°C until further analysis. After collecting xylem sap, shoots and roots of the plants were harvested for leaf area and mass (fresh and dry) determination. Oven-dried (80°C) tissues were used for nitrogen and TNC analyses.

CK Analysis

We used a simplified method for quantifying CKs in potentially active forms in the xylem sap and leaves. This method was based on the conversion of 9-ribosides and nucleotides to bases, purification of the total bases using HPLC, and their quantification by scintillation proximity immunoassay (Wang et al., 1995). Some modifications to this method were made for processing cotton xylem sap and leaf tissues and these will be described in the following section. During this conversion, only the 9-ribosides and nucleotides were converted to bases, whereas the *O*-, 7-, and 9-glucoside linkages were not cleaved appreciably.

Leaf Extract Preparation and Treatment

The ethanol, methanol, and acetic acid used throughout this study were of analytical grade (water content < 0.2% [w/w]). Proportions of all solvents in mixtures given below are on a volume basis unless indicated otherwise. All evaporations were performed using a rotary evaporator connected to a water pump (Wang et al., 1995). Leaf tissues were ground in liquid nitrogen and extracted with methanol:water:formic acid (15:4:1, 20 mL per gram of tissue) after enzyme inactivation at -20°C (Singh et al., 1988). Recovery markers (approximately 2,000 dpm of [³H]S-DZ [407 TBq mol⁻¹], [³H]R,S OGDZ [400 TBq mol⁻¹], and [³H]diH-iP [800 TBq mol⁻¹]) were added to the homogenate to correct for losses during purification. The tissue and solvent were left at 4°C for 18 h with intermittent stirring. The extraction process with methanol:water:formic acid (15:4:1) was repeated three times. The extracts were evaporated in 20-mL glass vials and traces of water were removed by addition and evaporation of absolute ethanol.

To cleave CK 9-ribosyl moieties in the dried residue by methanolysis, the following were added per gram of tissue fresh weight: methanol, 1 mL; 2,2-dimethoxypropane, 0.2 mL; and concentrated hydrochloric acid (36%, [w/w], 50 μL; Wang et al., 1995). The vials were sealed with plastic film, swirled to dissolve the residue, and left at 25°C for 40 h. The solution was evaporated to dryness under reduced pressure at 25°C and ethanol (2 mL per gram fresh weight of tissue) was then added and evaporated. Traces of residual acid was neutralized by addition of dilute ammonia and then evaporated. The residue was dissolved in water (pH 7) and extracted with water-saturated *n*-butanol (four times with an equal volume). The bases in the evaporated extracts were then purified by column chromatography.

Chromatographic Fractionation of Leaf Extracts Prior to Scintillation Proximity Assay (SPA)

The CK bases extracted by butanol were first purified by cation exchange using a column of silica propylsulphonic acid (Bakerbond, 40 μm, J.T. Baker, Phillipsburgh, NJ; 0.4 g packing per gram fresh weight), which was prepared by washing sequentially with 5% (v/v) pyridine, water, 0.5 M acetic acid until the effluent pH was 2.8 to 3.0, and then 0.05 M acetic acid. An aqueous solution (pH 2.8) of the

sample was passed through the column, which was then washed with 0.05 M acetic acid (3 column volumes [cv]), followed by water (1.5 cv), and then eluted with 5% (v/v) pyridine (3 cv). Eluted CK bases were further purified on solid phase extraction silica C₁₈ columns (J.T. Baker; 0.5 g packing, 1 mL cv), which had been washed sequentially with methanol:acetic acid (100:1), methanol:water:acetic acid (50:50:1), methanol:water:acetic acid (30:70:1), and then water (MilliQ, Waters, Milford, MA). After passage of the aqueous sample solution, the column was washed with water (2 cv, fraction 1), water (2 cv, fraction 2), and ethanol:water:acetic acid ([80:20:1], 4 cv, fraction 3). Small aliquots from the three fractions were monitored for radioactivity by liquid scintillation counting. A high percentage of radioactivity was detected in fraction 3, which contained the CK bases. These fractions were evaporated and redissolved in the starting mobile phase (25% [v/v] methanol) for the HPLC system. HPLC was carried out with equipment supplied by Waters (Hocart et al., 1998).

Xylem Sap Preparation, Treatment, and Purification

Prior to the actual experiment, a series of preliminary studies with radioactive CKs was carried out to ensure that we retained CK nucleotides as well as bases, ribosides, and glucosides during sample purification using the silica C₁₈ column chromatography. Nucleotides of CKs are often discarded unknowingly during sample purification, despite their special significance in CK metabolism and physiology (Letham and Palni, 1983). The pH of the xylem sap (3–10 mL) was adjusted to pH 3 by adding 100 μL of 1.5 M formic acid. Recovery markers (approximately 2,000 dpm of [³H]DZ, [³H]OGDZ, and [³H]diH-iP), were added to the sap to correct for losses during purification. The C₁₈ columns (J.T. Baker; 0.5 g packing, 1 mL cv) had been washed sequentially with methanol:acetic acid (100:1), methanol:water:acetic acid (50:50:1), methanol:water:acetic acid (30:70:1), and then water (MilliQ, Waters). After passage of the sample solution, the column was washed with acidified water (water adjusted to pH 3 with acetic acid, 2 cv, fraction 1), acidified water (2 cv, fraction 2), ethanol:water:acetic acid ([80:20:1], 2 cv, fraction 3), and again ethanol:water:acetic acid ([80:20:1], 2 cv, fraction 4). Small aliquots from the four fractions were monitored for radioactivity by liquid scintillation counting. A high level of radioactivity was only detected in fraction 3. Fraction 3 was then evaporated and traces of water were removed by the addition and evaporation of absolute ethanol. The dried residue was subjected to an anhydrous methanolysis process (see above) that converts any ribosides and nucleotides present in the purified sap to bases. The resulting solution containing the bases (free and released) was evaporated and redissolved in the starting mobile phase (25% [v/v] methanol) for the HPLC system.

HPLC

OGZ, OGDZ, Z, DZ, and iP (injection volume of 65–100 μL) were base-line separated within 60 min on a C₁₈ column (Platinum 100Å 5 μm, 250 mm × 4.6 mm, Alltech,

Deerfield, IL) eluted with a triethylamine buffer-methanol gradient at 1 mL min⁻¹. Solvent A was 40 mM acetic acid, pH adjusted to 3.78 to 3.80 with triethylamine; Solvent B was methanol. The column was eluted isocratically with 25% (v/v) methanol for 40 min, then a linear gradient to 60% (v/v) methanol in 3 min, and finally isocratically at 60% (v/v) methanol for 17 min. All solvents were degassed and filtered through a 0.45-μm filter. Prior to each analysis the column was washed with 95% (v/v) methanol. The absorbance of the column effluent was monitored at 254 and 269 nm with a programmable multiwavelength detector (490, Waters). Fractions were collected into plastic scintillation vials (Mini Poly-Q, 6 mL, Beckman, Fullerton, CA). The quality of the chromatography was monitored at regular intervals with CK standards. The CK fractions were identified by retention time and the radioactivity corresponding to ³H-OGDZ, ³H-DZ, and ³H-diH-iP. The putative iP fraction collected from the first HPLC run was subjected to a second HPLC run (40% [v/v] methanol isocratically at 1 mL min⁻¹ for 45 min). We exercised caution in attributing CK activity to iP-type compounds because the antibodies raised against iP-riboside will also cross react with benzylaminopurine and related compounds (Badenoch-Jones et al., 1987; Nandi et al., 1989). Thus iP fractions were subjected to two HPLC steps to resolve iP from cross-reactivities represented by potential benzylaminopurine and benzylaminopurine-like substances in the purified xylem sap. One of the substances had a similar retention volume to benzylaminopurine, but as yet has not been conclusively identified.

Digestion and Chromatographic Fractionation of O-Glucosides Analysis Prior to SPA

Fractions containing either putative OGZ or OGDZ were subjected to β-glucosidase (chromatographically purified grade, Sigma Chemicals, St. Louis) digestion for 12 h at 37°C. After digestion, fractions were evaporated and rechromatographed on C₁₈ solid phase extraction columns (J.T. Baker, 0.5 g packing, 1 mL cv) that had been washed sequentially with methanol:acetic acid (100:1), methanol:water:acetic acid (50:50:1), methanol:water:acetic acid (30:70:1), and then water (MilliQ, Waters).

SPA

The immunoassay utilized antisera and radiolabeled ligand tracers (riboside dialcohols) described previously (Badenoch-Jones et al., 1984, 1987; Wang et al., 1995) and SPA reagent (Type 1, protein A) purchased from Amersham International (Little Chalfont, Bucks, UK). The reagent (lyophilized fluromicrospheres) nominally sufficient for 500 assays was dissolved in the assay buffer (50 mL; 0.01 M sodium phosphate containing 0.15 M NaCl, pH 7.4). Antisera were diluted as follows: ZR, 1:1,400; DZR, 1:1,200; and iP riboside, 1:1,200. Solutions of CK standards (iP, Z, and DZ; 0.01–10 ng) or samples were evaporated on the bottom of small (15 × 50 mm) plastic scintillation vials (Mini Poly-Q, 6 mL, Beckman) to which the following were then added: tracer solution in assay buffer (200 μL, 10,000 dpm), diluted antiserum (100 μL), and a stirred suspension of the fluromicrospheres (100 μL). Vials were also prepared containing

microspheres and tracer, but no antiserum or CK, to determine non-specific binding, and vials with all additions except CK, to serve as zero standard (B_0). The vials were placed on a shaker at 25°C for 17 h and then radioactivity (cpm) was determined using a liquid scintillation counter (LS3801, Beckman). Standard curves were linearized over the measured range by logit transformation of B/B_0 , values plotted against log (nanograms of CK). All CK standards were assayed in triplicate and unknowns in duplicate.

Tissue Analysis of Nitrogen and TNC

Leaf nitrogen content was measured using an elemental analyzer (EA 1110, CE Instruments, Italy) that was periodically calibrated with glucosamine standards. The TNC in leaf and stem tissues were determined according to Wong (1990) and used for calculating structural dry matter content.

ACKNOWLEDGMENTS

We thank Josette Masle and Kim Gan for discussion, Win Coupland and Peter Groeneveld for excellent technical assistance, and the anonymous reviewer for valuable comments. We would like to acknowledge John Passioura and Jon Comstock for providing us with valuable suggestions for the construction of the pressure chamber.

Received March 31, 2000; accepted June 19, 2000.

LITERATURE CITED

- Arp WJ (1991) Effects of source-sink relations on photosynthetic acclimation to elevated CO_2 . *Plant Cell Environ* **14**: 869–875
- Badenoch-Jones J, Letham DS, Parker CW, Rolfe BG (1984) Quantification of cytokinins in biological samples using antibodies against zeatin riboside. *Plant Physiol* **75**: 1117–1125
- Badenoch-Jones J, Parker CW, Letham DS (1987) Use of isopentyladenosine and dihydrozeatin riboside antibodies for the quantification of cytokinins. *J Plant Growth Regul* **6**: 159–182
- Beck E, Wagner BM (1994) Quantification of the daily cytokinin transport from the root to the shoot of *Urtica dioica* L. *Bot Acta* **107**: 342–348
- Čatský J, Pospíšilová J, Macháèková I, Wilhelmová N, Šesták Z (1993) Photosynthesis and water relations in transgenic tobacco plants with T-DNA carrying gene 4 for cytokinin synthesis. *Biol Plant* **35**: 393–399
- Chen CM, Ertl JR, Leisner SM, Chang CC (1985) Localization of cytokinin biosynthetic sites in pea plants and carrot roots. *Plant Physiol* **78**: 510–513
- D'Agostino IB, Kieber JJ (1999) Molecular mechanisms of cytokinin action. *Curr Opin Plant Biol* **2**: 359–364
- Drake BG, Gonzalez-Meler MA, Long SP (1997) More efficient plants: a consequence of rising atmospheric CO_2 . *Annu Rev Plant Physiol Plant Mol Biol* **48**: 609–639
- Else MA, Davies WJ, Whitford PN, Hall KC, Jackson MB (1994) Concentrations of abscisic acid and other solutes in xylem sap from root systems of tomato and castor-oil plants are distorted by wounding and variable sap flow rates. *J Exp Bot* **45**: 317–323
- Else MA, Hall KC, Arnold GM, Davies WJ, Jackson MB (1995) Export of abscisic acid, 1-aminocyclopropane-1-carboxylic acid, phosphate, and nitrate from roots to shoots of flooded tomato plants. *Plant Physiol* **107**: 377–384
- Fusseder A, Wagner B, Beck E (1988) Quantification by ELISA of cytokinins in root-pressure exudates of *Urtica dioica* plants grown under different nitrogen levels. *Bot Acta* **101**: 214–219
- Gaudio RJ, Pikaard CS (1997) Cytokinin induction of RNA polymerase I transcription in *Arabidopsis thaliana*. *J Biol Chem* **272**: 6799–6804
- Hewitt EJ, Smith TA (1975) *Plant Mineral Nutrition*. English Universities Press, London
- Hocart CH, Wang J, Letham DS (1998) Derivatives of cytokinins for negative ion mass spectrometry. *J Chrom* **811**: 246–249
- Jackson MB (1993) Are plant hormones involved in root to shoot communication? *Adv Bot Res* **19**: 103–187
- Janes BE, Gee GW (1973) Changes in transpiration, net carbon dioxide assimilation and leaf water potential resulting from application of hydrostatic pressure to roots of intact pepper plants. *Physiol Plant* **28**: 201–208
- John PCL, Zhang K, Dong C, Diederich L, Wightman F (1993) $p34^{cd2}$ related proteins in control of cell cycle progression, the switch between division and differentiation in tissue development, and stimulation of division by auxin and cytokinin. *Aust J Plant Physiol* **20**: 503–526
- Jokhan AD, Harink RJ, Jackson MB (1999) Concentration and delivery of abscisic acid in xylem sap are greater at the shoot base than at a target leaf nearer to the shoot apex. *Plant Biol* **1**: 253–260
- Kinsman EA, Lewis C, Davies MS, Young JE, Francis D, Vilhar B, Ougham HJ (1997) Elevated CO_2 stimulates cells to divide in grass meristem: a differential effect in two natural populations of *Dactylis glomerata*. *Plant Cell Environ* **20**: 1309–1316
- Komor E, Liegl I, Schober C (1993) Loading and translocation of various cytokinins in phloem and xylem of the seedlings of *Ricinus communis* L. *Planta* **191**: 252–255
- Laureys F, Smets R, Lenjou M, Van Bockstaele D, Inze D, Van Onckelen H (1999) A low content in zeatin type cytokinins is not restrictive for the occurrence of G_1/S transition in tobacco BY-2 cells. *FEBS Lett* **460**: 123–128
- Lejeune P, Bernier G, Requier MC, Kinet JM (1994) Cytokinins in phloem and xylem saps of *Sinapis alba* during floral induction. *Physiol Plant* **90**: 522–528
- Letham DS (1994) Cytokinins as phytohormone: sites of biosynthesis, translocation and function of translocated cytokinin. In DWS Mok and MC Mok, eds, *Cytokinins: Chemistry, Activity, and Function*. CRC Press, Boca Raton, FL, pp 57–80
- Letham DS, Palni LMS (1983) The biosynthesis and metabolism of cytokinins. *Annu Rev Plant Physiol* **34**: 163–197
- Liang J, Zhang J (1997) Collection of xylem sap at flow rate similar to *in vivo* transpiration flux. *Plant Cell Physiol* **38**: 1375–1381

- Masle J** (2000) The effects of elevated [CO₂] on cell division rates, growth patterns and blade anatomy in young wheat plants are modulated by factors related to leaf position, vernalization and genotype. *Plant Physiol* **122**: 1399–1416
- Miller A, Tsai CH, Hemphill D, Endres M, Rodermeil S, Spalding M** (1997) Elevated CO₂ effects during leaf ontogeny: a new perspective on acclimation. *Plant Physiol* **115**: 1195–1200
- Munns R, Passioura JB** (1984) Hydraulic resistance of plants: III. Effects of NaCl in barley and lupin. *Aust J Plant Physiol* **11**: 351–359
- Nandi SK, Letham DS, Palni LMS, Wong OC, Summons RE** (1989) 6-Benzylaminopurine and its glycosides as naturally occurring cytokinins. *Plant Sci* **61**: 189–196
- Nooden LD, Letham DS** (1993) Cytokinin metabolism and signalling in the soybean plant. *Aust J Plant Physiol* **20**: 639–653
- Passioura JB** (1980) The transport of water from soil to shoot in wheat seedlings. *J Exp Bot* **31**: 333–345
- Pritchard SG, Rogers HH, Prior SA, Peterson CM** (1999) Elevated CO₂ and plant structure: a review. *Global Change Biol* **5**: 807–837
- Ranasinghe S, Taylor G** (1996) Mechanism for increased leaf growth in elevated CO₂. *J Exp Bot* **47**: 349–358
- Rayle DL, Ross CW, Robinson N** (1982) Estimation of osmotic parameters accompanying zeatin-induced growth of detached cucumber cotyledons. *Plant Physiol* **70**: 1634–1636
- Riou-Khamlichi C, Huntley R, Jacqmard A, Murray JAH** (1999) Cytokinin activation of *Arabidopsis* cell division through a D-type cyclin. *Science* **283**: 1541–1544
- Rogers HH, Prior SA, Runion GB, Mitchell RJ** (1996) Root to shoot ratio of crops as influenced by CO₂. *Plant Soil* **187**: 229–248
- Sage RF** (1994) Acclimation of photosynthesis to increasing atmospheric CO₂: the gas exchange perspective. *Photosynth Res* **39**: 351–368
- Sakakibara H, Suzuki M, Takei K, Deji A, Taniguchi M, Sugiyama T** (1998) A response-regulator homologue possibly involved in nitrogen signal transduction mediated by cytokinin in maize. *Plant J* **14**: 337–344
- Salama AMSEDA, Wareing PF** (1979) Effect of mineral nutrition on endogenous cytokinins in plants of sunflower *Helianthus annuus* L. *J Exp Bot* **30**: 971–981
- Samuelson ME, Eliasson L, Larsson C** (1992) Nitrate-regulated growth and cytokinin responses in seminal roots of barley. *Plant Physiol* **98**: 309–315
- Sattelmacher B, Marschner H** (1978) Nitrogen nutrition and cytokinin activity in *Solanum tuberosum*. *Physiol Plant* **42**: 185–189
- Schurr U** (1998) Xylem sap sampling: new approaches to an old topic. *Trend Plant Sci* **3**: 293–298
- Sims DA, Luo Y, Seemann JR** (1998a) Importance of leaf versus whole plant CO₂ environment for photosynthetic acclimation. *Plant Cell Environ* **21**: 1189–1196
- Sims DA, Seemann JR, Luo Y** (1998b) Elevated CO₂ concentration has independent effects on expansion rates and thickness of soybean leaves across light and nitrogen gradients. *J Exp Bot* **49**: 583–591
- Singh S, Letham DS, Jameson PE, Zhang R, Parker CW** (1988) Cytokinin biochemistry in relation to leaf senescence: IV. Cytokinin metabolism in soybean explants. *Plant Physiol* **88**: 788–794
- Stitt M** (1991) Rising CO₂ levels and their potential significance for carbon flow in photosynthetic cells. *Plant Cell Environ* **14**: 741–762
- Stitt M** (1999) Nitrate regulation of metabolism and growth. *Curr Opin Plant Biol* **2**: 178–186
- Stitt M, Krapp A** (1999) The interaction between elevated carbon dioxide and nitrogen nutrition: the physiological and molecular background. *Plant Cell Environ* **22**: 583–621
- Synková H, Wilhelmová N, Šesták Z, Pospíšilová J** (1997) Photosynthesis in transgenic plants with elevated cytokinin contents. In M Pessaraki, ed, *Handbook of Photosynthesis*. Marcel Dekker, New York, pp 514–552
- Taylor CB** (1997) Plant vegetative development: from seed and embryo to shoot and root. *Plant Cell* **9**: 981–988
- Torrey JG** (1976) Root hormones and plant growth. *Annu Rev Plant Physiol* **27**: 435–459
- Van Staden J, Dimalla GG** (1981) The production and utilisation of cytokinins in rootless, dormant almond shoots maintained at low temperature. *Z Pflanzenphysiol* **103**: 121–129
- Vonk CR** (1979) Origin of cytokinins transported in the phloem. *Physiol Plant* **46**: 235–240
- Wagner BM, Beck E** (1993) Cytokinins in the perennial herb *Urtica dioica* L. as influenced by its nitrogen status. *Planta* **190**: 511–518
- Wang J, Letham DS, Taverner E, Badenoch-Jones J, Houghton CH** (1995) A procedure for quantification of cytokinins as free bases involving scintillation proximity immunoassay. *Physiol Plant* **95**: 91–98
- Wingler A, von Schaewen A, Leegood RC, Lea PJ, Quick WP** (1998) Regulation of leaf senescence by cytokinin, sugars and light: effects on NADH-dependent hydroxypyruvate reductase. *Plant Physiol* **116**: 329–335
- Wong SC** (1990) Elevated atmospheric partial pressure of CO₂ and plant growth: II. Non-structural carbohydrate content in cotton plants and its effect on growth parameters. *Photosynth Res* **23**: 171–180
- Zhang K, Letham DS, John PCL** (1996) Cytokinin controls the cell cycle at mitosis by stimulating the tyrosine dephosphorylation and activation of p34^{cdc2}-like H1 histone kinase. *Planta* **200**: 2–12
- Ziegler H** (1975) Nature of transported substances. In MM Zimmermann and JA Milburn, eds, *Encyclopedia of Plant Physiology*, New Series, Vol 1. Springer-Verlag, Berlin, pp 59–100