

Efficient Promoter Cassettes for Enhanced Expression of Foreign Genes in Dicotyledonous and Monocotyledonous Plants

Ichiro Mitsuhashi¹, Masashi Ugaki¹, Hirohiko Hirochika¹, Masahiko Ohshima¹, Taka Murakami¹, Yoko Gotoh¹, Yuichi Katayose¹, Shigeo Nakamura^{1,2}, Ryoso Honkura², Satoshi Nishimiya^{1,3}, Keiichiro Ueno^{1,4}, Atsushi Mochizuki^{1,5}, Hideo Tanimoto^{1,7}, Hidehito Tsugawa^{6,8}, Yoshiaki Otsuki^{1,6} and Yuko Ohashi^{1,9}

¹ National Institute of Agrobiological Resources, Tsukuba, Ibaraki, 305 Japan

² Miyagi Prefectural Agricultural Research Center, Natori, Miyagi, 981-12 Japan

³ Ibaraki Horticultural Research Station, Iwama, Ibaraki, 311-32 Japan

⁴ Kagoshima Biotechnology Institute, Kushira, Kagoshima, 893-16 Japan

⁵ Tohoku National Agricultural Experimental Station, Omagari, Akita, 014-01 Japan

⁶ National Agriculture Research Center, Tsukuba, Ibaraki, 305 Japan

⁷ Osaka Prefectural Agricultural and Forestry Research Center, Habikino, Osaka, 583 Japan

⁸ Aomori Green BioCenter, Aomori, 030-01 Japan

A series of chimeric promoters for higher-level expression of foreign genes in plants was constructed as fusions of a gene for β -glucuronidase (GUS) with the terminator of a gene for nopaline synthase (*nos*) or of the cauliflower mosaic virus (CaMV) 35S transcript, and the strength of these promoters was assayed in transient and stable expression systems in tobacco and rice. As parts of these promoters, the CaMV 35S core promoter, three different 5'-upstream sequences of the 35S promoter, the first intron of a gene for phaseolin, and a 5'-untranslated sequence (Ω sequence) of tobacco mosaic virus were used in various combinations. In tobacco and rice protoplasts, all three fragments of the 35S promoter (-419 to -90, -390 to -90 and -290 to -90, relative to the site of initiation of transcription), the intron, and the Ω sequence effectively enhanced GUS activity. Some chimeric promoters allowed levels of GUS activity that were 20- to 70-fold higher than those obtained with the 35S promoter in pBI221. In tobacco protoplasts, the two longer fragments of the 35S promoter were more effective than the shortest fragment. In rice cells, by contrast, the shortest fragment was as effective as the two longer ones. The terminator of the 35S transcript was more effective than that of the *nos* gene for gene expression. In transgenic tobacco plants, a representative powerful promoter, as compared to the 35S promoter, allowed 10- and 50-fold higher levels of expression on average and at most, respectively, with no clear qualitative differences in tissue- and organ-specific patterns of expression. When the representative promoter was introduced into tobacco with a gene for luciferase, the autofluorescence of detached

leaves after a supply of luciferin to petioles was great and was easily detectable by the naked eye in a dark room.

Key words: CaMV 35S promoter — Gene expression — Rice (*Oryza sativa*) — Strong promoter — TMV Ω sequence — Tobacco (*Nicotiana tabacum*).

Promoters regulate gene expression both quantitatively and qualitatively. The regulatory sequences of promoters that define the qualitative specificity of gene expression in plants have been studied and much information has accumulated in recent years (Hennig et al. 1994). However, details of the fine regulation of levels of the expression of transgenes have not been easy to obtain because of the limited kinds of promoter available. The cauliflower mosaic virus (CaMV) 35S promoter, which has been most frequently used as a constitutive strong promoter in plants (Benfey and Chua 1990, Terada and Shimamoto 1990, Yang and Christou 1990) results in a level of expression that is insufficient for some purposes. For example, content of coat protein was only 0.1% of the total leaf protein and resistance to infection by tobacco mosaic virus (TMV) was not very great in a transgenic tobacco plant that contained a chimeric gene composed of the 35S promoter and the gene for the TMV coat protein (Powell et al. 1986). Because the level of viral resistance is dependent on the level of accumulated coat protein (Beachy et al. 1990), resistance should be improved if the level of expression of the coat protein gene could be increased by use of a promoter stronger than the 35S promoter. The level of expression of an introduced antisense gene driven by the 35S promoter was also found to be insufficient in transgenic plants for complete inhibition of expression of ADP-glucose pyrophosphorylase (Müller-Röber et al. 1992) and a sucrose transporter (Reismeyer et al. 1994).

Abbreviations: CaMV, cauliflower mosaic virus; CAT, chloramphenicol acetyl transferase; GUS, β -glucuronidase; LUC, luciferase; 4-MU, 4-methyl-umbelliferyl glucuronide; *nos*, gene for nopaline synthase gene, PCR, polymerase chain reaction; TMV, tobacco mosaic virus; X-gluc, 5-bromo-4-chloro-3-indolyl glucuronide.

⁹ To whom correspondence should be addressed.

Several other sequences have been reported to enhance the expression of foreign genes. A 5'-upstream region of the 35S promoter (−343 to −90) was found to act as an enhancer sequence in higher plants (Odell et al. 1988). It contains many types of *cis* element that confer tissue-specific expression (Fang et al. 1989, Benfey and Chua 1990). When this upstream region was used in two tandem repeats as an enhancer, the level of gene expression increased with increases in the number of regions (Kay et al. 1987, Timmermans et al. 1990, Omirulleh et al. 1993).

Introns in some genes have been postulated to stimulate gene expression by increasing the stability of the corresponding mRNAs in the case of both animal cells and their viruses (Gruss and Houry 1980, Buchman and Berg 1988, Huang and Gorman 1990). Certain plant introns have also been shown to increase the level of expression of homologous or heterologous genes (Callis et al. 1987, McElroy et al. 1990, Clancy et al. 1994). When the first intron of a gene for phaseolin, a storage protein of the common bean *Phaseolus vulgaris* (Slightom et al. 1983), was inserted in the 5'-upstream region of a gene for chloramphenicol acetyl transferase (CAT), a 10-fold enhancement of gene expression was observed in rice protoplasts (Hirochika et al. in preparation).

Tobacco mosaic virus (TMV) has a unique G-free sequence (Ω sequence) in the 5'-untranslated region of its genomic RNA. This sequence was reported to improve the efficiency of translation in plant, animal and *E. coli* cells, in vitro and in vivo (Sleat et al. 1987, Gallie et al. 1991), probably by preventing the formation of secondary structure of mRNA and/or enhancing interactions between mRNA and ribosomes.

The terminator of chimeric genes also plays an important role in gene expression by affecting the stability of mRNA (Engelbrecht et al. 1989). In plants, the 3'-untranslated region of the CaMV 35S transcript and that of the gene for nopaline synthase (*nos*) in the Ti plasmid (Bevan et al. 1983) are often used as terminators.

Although the individual elements listed above have been reported to affect gene expression, there have been no reports on the effects of combinations of these sequences together in monocotyledonous and dicotyledonous plants. In this study, we constructed a series of promoter cassettes that contained specific sequences in an attempt to induce higher levels of expression of transgenes in plants. The levels of expression of the various constructs were analyzed to evaluate the effects of the different elements in transient and stable expression systems in tobacco and rice.

Materials and Methods

Construction of promoter-GUS chimeric genes—DNA was manipulated as described by Maniatis et al. (1989), and recombinant polymerase chain reaction (PCR) was carried out as de-

scribed by Higuchi (1989). Plasmids pBI221 and pBI121 (Jefferson et al. 1987) were products of Clontech (Palo Alto, CA, U.S.A.). Plasmid pFF19G (Timmermans et al. 1990) was a gift from Prof. J. Messing (Rutgers University). Plant expression vectors pREX-1, pEN4 and pEN6 were made by Hirochika et al. (in preparation). The gene for luciferase (LUC) was obtained as a restriction fragment from pT3/T7-Luc (Clontech).

The promoter region of the CaMV 35S transcript was amplified by PCR from pBI221 with A5 (5'-ATCTCCACTGACGTAAGGGATGACG-3') and A3 (5'-TTGTAAAAATACGTACCTCTCCAAATGAAATGAACTTCC-3') as primers. The Ω sequence of TMV was amplified from TMV cDNA clone pL₁₁A-A25 (Nishiguchi et al. 1985) with B5 (5'-TTTCATTTGGAGAGGTACGTATTTTTACAACAATTACCAACAA-3') and B3 (5'-GTACGAGCTCTGATCAACGTCCATGGTGGATCCTCTAGATGTAGTTGTAGAATGTAAAATGTAATGTTG-3') as primers.

Closed circular plasmid DNA for electroporation was purified by CsCl/ethidium bromide density gradient centrifugation. The GUS fusion in the binary vector pBI121 (Clontech) was replaced by constructed GUS fusions, inserted at the *Hind*III and *Eco*RI sites. Each resulting construction was used to transform *Agrobacterium tumefaciens* strain LBA4404 (Ooms et al. 1981) by electroporation.

Analysis of transient expression—The transient expression of GUS fusion constructs was analyzed as follows. Tobacco mesophyll protoplasts were prepared from fully expanded upper leaves of *Nicotiana tabacum* cv. Samsun NN. The lower epidermis of a sterilized tobacco leaf was abraded with carborundum (mesh 600; Kishida Chemicals Co., Osaka, Japan) to facilitate penetration of the wall-degrading enzymes, and the pieces of leaves were floated on 0.5 M mannitol that contained 1% cellulase Onozuka R-10 (Yakult Co., Tokyo, Japan) and 0.02% pectolyase Y-23 (Seishin Pharmaceutical Co., Tokyo, Japan) at 28°C with occasional agitation. After digestion for 2 h, the protoplasts were filtered through 80- μ m nylon mesh, collected by centrifugation at 100 \times g for 2 min and then washed twice with 0.5 M mannitol. The viability of the protoplasts was determined by staining with Evans Blue (Wako Chemicals Co., Osaka, Japan).

Isolated protoplasts (10⁵ cells) were carefully resuspended in 0.5 ml of 0.5 M mannitol that contained 10 μ g of purified supercoiled plasmid DNA which included various promoter fusion constructs and 100 μ g of carrier DNA (salmon sperm DNA, 0.5 kb in average length; Wako Chemicals Co.). Electroporation was performed at 500 V cm⁻¹ for 15–20 ms on ice, in a cuvette with a 0.4-cm electrode gap, in a dielectrophoretic cell-fusion processor (model SCF1A; Sankei Co., Tokyo, Japan). Electroporated protoplasts were kept on ice for 15–30 min, collected by centrifugation, and then cultured at 28°C in darkness in 0.5 ml of medium that contained inorganic salts (Murashige and Skoog 1962), vitamins for B5 medium (Gamborg et al. 1968), 5 μ M 2,4-D, 2.5 μ M kinetin and 0.4 M glucose.

Rice protoplasts were prepared from suspension-cultured cells of *Oryza sativa* cv. Nipponbare. Isolation and electroporation were carried out as described previously (Kosugi et al. 1990).

Analysis of stable expression—Tobacco plants were transformed by infection with *A. tumefaciens* LBA4404 that carried the modified binary vectors by the leaf disc-method (Horsch et al. 1985). Transformants were selected in the presence of 100 μ g ml⁻¹ kanamycin. GUS activity in the upper fully-expanded leaves of regenerated transformants was analyzed at a similar growth stage.

Transformation of rice was carried out as described by Sugimoto et al. (1994). Protoplasts were prepared from rice sus-

pension-cultured cells (cv. Nipponbare). Cells ($1.5 \times 10^6 \text{ ml}^{-1}$) were electroporated in a continuous flow electro-transfector (CET-100; JASCO, Tokyo, Japan) in 0.5 M mannitol that contained 0.1 mM MgSO_4 , $20 \mu\text{g ml}^{-1}$ sonicated calf thymus DNA as carrier DNA, $2 \mu\text{g}$ of plasmid DNA that included a fusion construct and $0.4 \mu\text{g}$ of plasmid that contained the CaMV 35S promoter and the gene for hygromycin phosphotransferase (pUC19HPT; kindly provided by Dr. A. Kato) as a selectable marker gene. A rectangular electric pulse of $1,000 \text{ V cm}^{-1}$ was applied six times for 0.1 ms each. After a 10-day incubation in a conditioned medium, hygromycin-resistant calli were selected and integration of the fusion constructs was studied by PCR.

Analysis of GUS and LUC activities—GUS activity was analyzed by the fluorometric method of Kosugi et al. (1990) with 4-methyl-umbelliferyl glucuronide (4-MU) as a substrate. Histochemical staining for GUS was carried out as described by Ohshima et al. (1990). Tissue or pollen was stained in 50 mM phosphate buffer (pH 7.0) that contained 1 mM 5-bromo-4-chloro-3-indolyl glucuronide (X-Gluc) at 37°C in the presence of antibiotics. For the assay of LUC activity, expanded upper young leaves of transgenic plants that contained the LUC gene were detached. After absorption of $200 \mu\text{l}$ of a 1 mM solution of luciferin (Sigma, St. Louis, MO, U.S.A.) in 10 mM sodium-citrate buffer (pH 5.0) through the petiole, the leaves were photographed in a dark room on ISO 1600 film, with an exposure time of 10 min, and an aperture of F/1.7.

Results

Construction of promoter cassettes—The structures of the promoter cassettes that were constructed in this study are summarized in Figure 1. The cassettes were generated as follows. The CaMV 35S core promoter was prepared by PCR using primers A5 and A3. A3 includes a *Sna*BI site and a sequence complementary to the 5' region of the Ω sequence of TMV at its 5' end. The Ω sequence was prepared by PCR with primers B5 and B3. The B5 primer has a sequence identical to the 3' end of the CaMV 35S promoter, and the B3 primer has a polylinker sequence that contains *Xba*I, *Bam*HI, *Nco*I, *Bcl*I and *Sac*I sites. Products of PCR with the 35S promoter and the Ω sequence were fused by the recombinant PCR technique.

Fig. 1 Diagrams of all tested constructs. All constructs were inserted into *Hind*III and *Eco*RI restriction sites located within the polycloning sites of plasmid pUC18 or pBI121. E7: 5'-upstream sequence of CaMV 35S promoter (−940 to −290) and (−290 to −90) × 7. E12: 5'-upstream sequence of CaMV 35S promoter (−419 to −90) × 2. En4: 5'-upstream sequence of CaMV 35S promoter (−940 to −390) and (−390 to −90) × 4. En6: 5'-upstream sequence of CaMV 35S promoter (−940 to −390) and (−390 to −90) × 6. P35S: 5'-upstream sequence of CaMV 35S promoter (−90 to −1). Ω : 5'-untranslated sequence of TMV. Intron: first intron of a gene for phaseolin. GUS: protein-coding region of a gene for β -glucuronidase. LUC: protein-coding region of a gene for luciferase. Tnos: polyadenylation signal of the gene for nopaline synthase in the Ti plasmid. T35S: polyadenylation signal of the CaMV 35S transcript. B, *Bam*HI; E1, *Eco*RI; E5, *Eco*RV; H3, *Hind*III; Ns, *Nsi*I; Sc, *Sac*I; Sl, *Sal*I; Sm, *Sma*I; Sn, *Sna*BI; Sp, *Sph*I; P, *Pst*I; X, *Xba*I.

The *Nco*I site of the plant expression plasmid pREX-1, located in the 5'-upstream region of the 35S enhancer, was disrupted by digestion with *Nco*I that was followed by filling in with the Klenow fragment and self-ligation. The *Eco*RV-*Sac*I region of the resultant plasmid pREX-1' was

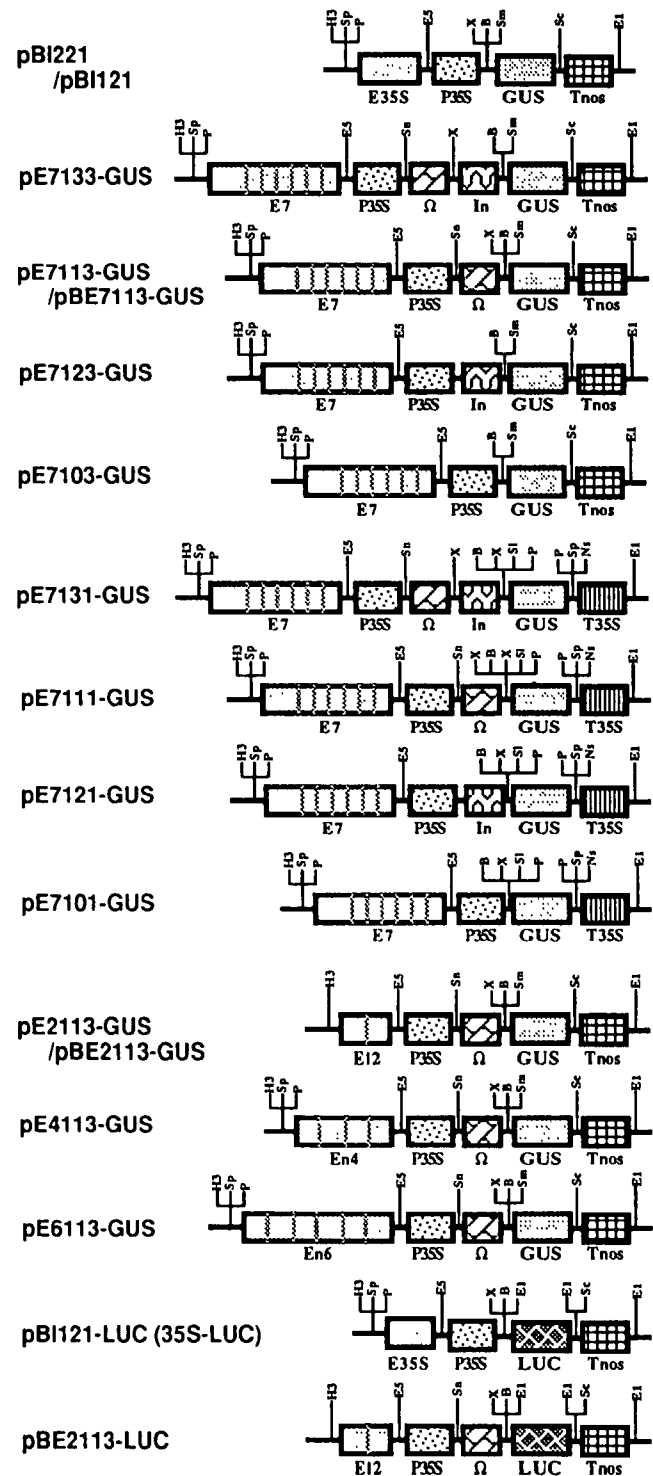

replaced by a product of recombinant PCR that contained the 35S core promoter and the Ω sequence to make pE7113 (E7 Ω). The plasmid pE7113 has seven tandemly repeated enhancer-like elements (-90 to -290 , relative to the site of initiation of transcription as $+1$) of the 35S promoter (E7), the 35S core promoter, the Ω sequence, the polylinker sequence, and the terminator of the *nos* gene. The first intron of the gene for phaseolin was obtained as an *Xba*I-*Bam*HI fragment of pREX-1 and inserted into the *Xba*I-*Bam*HI site of pE7113 (E7 Ω) to make pE7133 (E7 Ω In). Each regulatory sequence utilized in pE7133 (E7 Ω In) has unique flanking restriction sites those allow the sequences to be easily removed or replaced by other sequences. Accordingly, pE7123 (E7In) and pE7103 (E7) were produced by excision of the Ω sequence from pE7133 and pE7113, respectively, by *Sna*BI and *Xba*I digestion, blunting and ligation. The GUS gene was obtained as a *Bam*HI-*Sac*I fragment from pBI221 and inserted into pE7133, pE7113, pE7123 and pE7103 to produce pE7133-GUS (E7 Ω In-GUS), pE7113-GUS (E7 Ω -GUS), pE7123-GUS (E7In-GUS) and pE7103-GUS (E7-GUS), respectively.

Replacement of the *nos* terminator of the plasmid by the 35S terminator and cloning of the GUS gene was achieved by cloning the *Bam*HI-*Eco*RI fragment of pFF19G into the *Bam*HI and *Eco*RI sites in pE7133, pE7113, pE7123 and pE7103 to produce pE7131-GUS, pE7111-GUS, pE7121-GUS and pE7101-GUS, respectively. The enhancer-like element of pE7113 was replaced by *Hind*III and *Eco*RV fragments of pFF19G, pEN4, or pEN6. The resulting clones had different lengths and copy numbers of

enhancer-like elements from the 5'-upstream region of the 35S promoter; pE2113 had two tandem repeats of -419 to -90 (E12), pE4113 had four tandem repeats of -390 to -90 (En4), and pE6113 had six repeats of -390 to -90 (En6). The *Hind*III and *Eco*RI fragments were excised from pE7113-GUS (E7 Ω -GUS) and pE2113-GUS (E12 Ω -GUS) and recloned into a binary Ti plasmid pBI121 to yield the binary plasmids pBE7113-GUS (E7 Ω -GUS) and pBE2113-GUS (E12 Ω -GUS), respectively. In order to produce the expression vectors that contained the gene for LUC (pBI121-LUC and pBE2113-LUC), the gene for LUC was obtained as a *Bam*HI-*Sac*I fragment from pT3/T7-Luc and recloned into binary plasmids pBI121 (35S-GUS) and pBE2113-GUS (E12 Ω -GUS), respectively, at the *Bam*HI and *Sac*I site.

Analysis of transient expression in tobacco and rice protoplasts—To evaluate the promoter activities of the various constructs, the level of GUS activity in tobacco and rice protoplasts was examined one day after electroporation (Table 1). In tobacco mesophyll protoplasts, the level of GUS activity was about two or more orders of magnitude higher than that in rice protoplasts prepared from suspension-cultured cells on the basis of both cell number and protein concentration. All promoters presented in Table 1 conferred considerably higher GUS activity than the 35S promoter of pBI221 (35S-GUS). As compared to the level of expression of 35S-GUS, the levels of expression of tested constructs were 4- to 26-fold higher in tobacco cells and 1.5- to 76-fold higher in rice cells.

The Ω sequence of TMV increased GUS activity 2- to

Table 1 Transient expression of the GUS gene driven by various promoter constructs in tobacco and rice protoplasts

Name of plasmid	Structure of plasmid	GUS activity (4-MU nmol/10 ⁷ cells/min)			
		Tobacco		Rice	
			(Ratio)		(Ratio)
pBI221	35S - GUS - Tnos	50	(1.0)	0.27	(1.0)
pE7133-GUS	E7 - P35S - Ω - In - GUS - Tnos	860	(17.2)	18.5	(68.5)
pE7113-GUS	E7 - P35S - Ω - GUS - Tnos	430	(8.6)	5.6	(20.7)
pE7123-GUS	E7 - P35S - In - GUS - Tnos	195	(3.9)	1.9	(6.9)
pE7103-GUS	E7 - P35S - GUS - Tnos	Not tested		0.40	(1.5)
pE7131-GUS	E7 - P35S - Ω - In - GUS - T35S	1,170	(23.4)	20.5	(75.9)
pE7111-GUS	E7 - P35S - Ω - GUS - T35S	1,320	(26.4)	7.5	(27.8)
pE7121-GUS	E7 - P35S - In - GUS - T35S	725	(14.5)	4.4	(16.3)
pE7101-GUS	E7 - P35S - GUS - T35S	305	(6.1)	1.8	(6.5)
pE2113-GUS	E12 - P35S - Ω - GUS - Tnos	1,150	(23.0)	0.96	(3.6)
pE4113-GUS	En4 - P35S - Ω - GUS - Tnos	860	(17.2)	2.4	(9.0)
pE6113-GUS	En6 - P35S - Ω - GUS - Tnos	1,300	(26.0)	3.2	(11.9)

After electroporation, protoplasts were incubated for 24 h, and GUS activity was determined as described in Materials and Methods. The values relative to those obtained with pBI221 (35S-GUS construct) are shown in parentheses. All data are averages of results from four different experiments.

5-fold in tobacco and 4- to 10-fold in rice, as revealed by comparison of the activities of promoter constructs with and without Ω (pE7133-GUS vs. pE7123-GUS, pE7113-GUS vs. pE7103-GUS, pE7131-GUS vs. pE7121-GUS and pE7111-GUS vs. pE7101-GUS). In all four cases, the Ω sequence was quite effective in enhancing gene expression. Thus, this sequence was effective in both tobacco and rice cells.

The positive effect of the intron on the expression of fusion constructs was also clear in rice protoplasts. Comparison of data for pE7133-GUS vs. pE7113-GUS and pE7121-GUS vs. pE7101-GUS revealed an intron-mediated 3- to 5-fold enhancement of GUS activity. In tobacco cells, the effect of the intron was less clear, it induced only a doubling of GUS activity when pE7133-GUS (E7 Ω In-GUS) was compared to pE7113-GUS (E7 Ω -GUS) and pE7121-GUS to pE7101-GUS. Moreover, the intron had no effect on pE7131 as compared to pE7111.

All enhancer-like sequences of the 35S promoter used in this study [E12, (-419 to -90) \times 2; En4, (-940 to -390) + (390 to -90) \times 4; En6, (-940 to -390) + (-390 to -90) \times 6; and E7, (-940 to -290) + (-290 to -90) \times 7] increased GUS activity in both tobacco and rice cells but the extent of such enhancement varied. In tobacco cells, the two longer fragments with fewer repeats (E12, En4 and En6) conferred higher-level expression than the shorter sequence with more repeats (E7). For example, the levels of the activity associated with pE2113-GUS (E12 Ω -GUS), pE4113-GUS (En4 Ω -GUS) and pE6113-GUS (En6 Ω -GUS) were 2 to 3 times higher than that associated with pE7113-GUS (E7 Ω -GUS). By contrast, in rice cells, the shortest enhancer with the most repeats (E7) was the most effective

sequence, being 2 to 6 times more active than the longer enhancers with fewer repeats (En4, En6 and E12), as indicated by the transient expression of GUS from pE7113-GUS (E7 Ω -GUS), pE4113-GUS (En4 Ω -GUS), pE6113-GUS (En6 Ω -GUS) and pE2113-GUS (E12 Ω -GUS).

The effect of the terminator in the fusion constructs was studied with four different sets of promoters, namely, pE7133-GUS and pE7131-GUS, pE7113-GUS and pE7111-GUS, pE7123-GUS and pE7121-GUS, and pE7103-GUS and pE7101-GUS. In all cases, the terminator of the CaMV 35S transcript induced higher levels of GUS activity than that of the *nos* gene in both plant species (Table 1).

In tobacco protoplasts, pE2113 (E12 Ω), pE6113 (En6 Ω), pE7131 and pE7111 similarly caused extremely high-level expression equal to more than 20 times that of 35S-GUS. Among these constructs, pE2113 (E12 Ω) was selected as the representative of promoters of highest-level expression in dicotyledonous plants for further analysis because it was the shortest and had the simplest structure. The pE7113 construct (E7 Ω), with an expression level that was 8.6 times that of 35S-GUS, was selected as a moderately high-level expression promoter.

In rice protoplasts, pE7133 (E7 Ω InTnos) and pE7131 (E7 Ω InT35S) induced exceptionally high levels of expression, which were about 70 times higher than that induced by 35S-GUS. Construct pE7133 (E7 Ω InTnos) was selected as a representative of the highest-level expression promoters in monocotyledonous plants because of the ease of its construction, while pE7113 (E7 Ω) was taken as a moderately high-level expression promoter, causing expression at a level 21-fold higher than 35S-GUS.

Analysis of the promoters in tobacco and rice transfor-

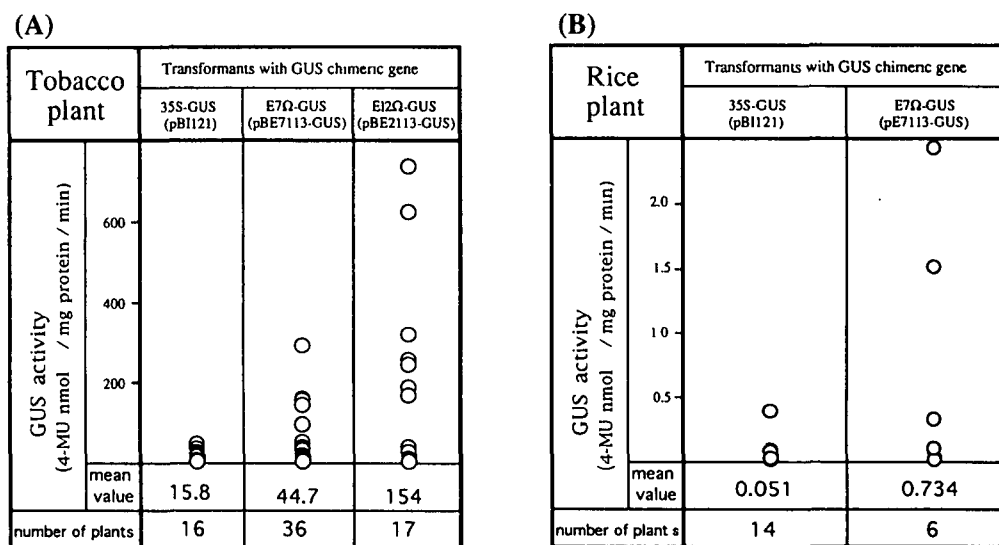

Fig. 2 Frequency distribution of levels of GUS activity in transgenic tobacco (A) and rice plants (B). Mean GUS activities and the numbers of plants used are shown at the bottom of the Figure.

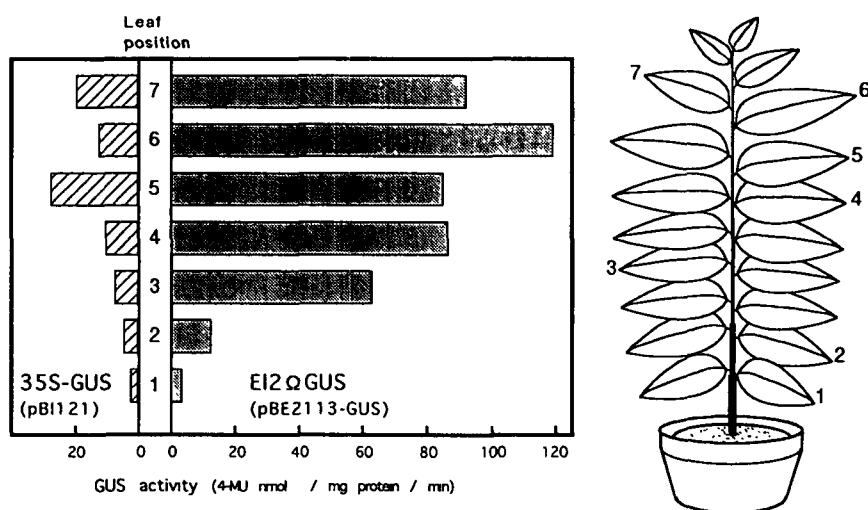

Fig. 3 Effect of leaf position on GUS activity in transgenic tobacco plants that carried 35S-GUS (pBI121) and EI2Ω-GUS (pBE2113-GUS). Data were obtained from a typical specimen of each transgenic plant.

mants—To study the characteristics of the constructed promoters in transgenic tobacco plants, *Hind*III and *Eco*RI fragments containing the entire promoter-GUS-terminator constructs from pE7113-GUS (E7Ω-GUS) and pE2113-GUS (EI2Ω-GUS) were inserted into the *Hind*III-*Eco*RI site of the binary vector pBI121, replacing of 35S-GUS gene. The resultant plasmids were introduced into *Agrobacterium tumefaciens* LBA4404. After inoculation of pieces of tobacco leaves with the bacterium, 30 to 40 kanamycin-resistant shoots were regenerated and rooted. The regenerated plants were transferred to soil, and GUS activity in the upper fully developed leaves was measured. No major differences were observed in the efficiency of transformation and regeneration or in morphology among all 30–40 transformants and the control non-transformants. As shown in Figure 2A, transformants with the EI2Ω-GUS and E7Ω-GUS promoters had apparently higher GUS activity than those with the 35S promoter. Compared with the level in transformants that carried 35S-GUS, the level of GUS activity in E7Ω-GUS and EI2Ω-GUS transformants was about 3 and 10 times higher on average, respectively. The highest levels of GUS activity in EI2Ω-GUS plants, E7Ω-GUS plants, and 35S-GUS plants were 733, 289, and 45 nmoles 4-MU mg protein⁻¹ min⁻¹, respectively.

GUS activity in the middle parts of leaf blades of

young transgenic rice plants that harbored pE7113-GUS (E7Ω-GUS) and pBI221 (35S-GUS) was determined. The frequency distribution of GUS activities in leaf extracts of transgenic rice is shown in Figure 2B. The overall level of GUS activity was much higher in the E7Ω-GUS population, being on average about 14 times higher than that in 35S-GUS plants. The highest levels of GUS activity in transformants with E7Ω-GUS and in those with 35S-GUS were 2.4 and 0.37 nmoles 4-MU mg protein⁻¹ min⁻¹, respectively.

It is important to characterize the specific mode expression of promoters at each developmental and spatial level. GUS activities of leaves at different positions on 35S-GUS and EI2Ω-GUS tobacco plants at a similar growth stage (when plants were about 120 cm in height) were determined (Fig. 3). In both 35S-GUS and EI2Ω-GUS plants, the activity was highest in the upper fully expanded leaves (leaf position 5–7 in Fig. 3), decreasing gradually in the leaves at lower position.

Histochemical analysis of the expression of strong promoters in transgenic tobacco plants—To study the mode of gene expression of the strong promoters, GUS activity was determined by histochemical staining of organs and tissues in transgenic tobacco plants. Figure 4 shows GUS activities in cross sections of leaf blades (A, B), longitudinal sections

Fig. 4 Histochemical examination of the expression of foreign genes in transgenic tobacco plants. Several parts of tissues or organs from transgenic tobacco (A–L) were subjected to analysis of GUS activity. (A, C, E, G, I, K) Transgenic tobacco plants containing pBI121 (35S-GUS). (B, D, F, H, J, L) Transgenic tobacco plants containing pBE2113-GUS (EI2Ω-GUS). (A, B) Leaf sections (100 μm thick) stained for 2 h at 37°C. Bar=200 μm. (C, D) Longitudinal sections of shoot apex (80 μm thick) stained for 1 h. Bar=500 μm. (E, F) Longitudinal sections of flowers, 4 days before flowering, stained for 1 h. Bar=500 μm. (G, H) Intact pollen grains stained for 2 h. Bar=20 μm. (I, J) Intact roots stained for 1 h. Bar=100 μm. (K, L) Intact seedlings, 4 days after imbibition, stained for 1 h. Bar=500 μm. (M) Autofluorescence of transgenic tobacco leaves that contained pBI121-LUC (left) and pBE2113-LUC (right). Luciferin was absorbed by leaves of transformants from petioles and autofluorescence was observed in a dark room. The photograph was taken on ISO 1600 film, with an exposure time of 10 min, and an aperture of F/1.7.

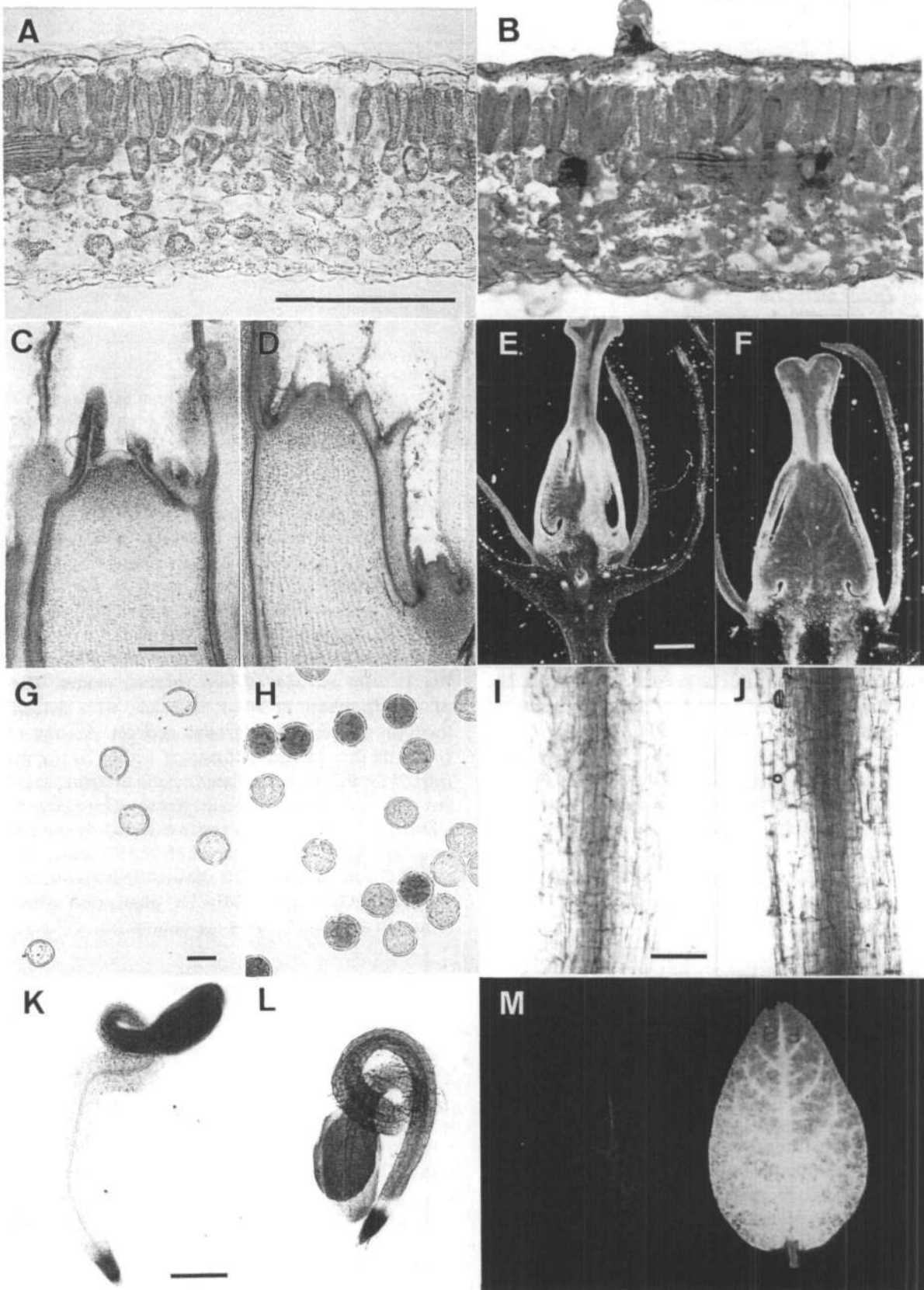

Table 2 GUS activity in various organs of transgenic tobacco seedlings of R1 progeny that harbored 35S-GUS and E12 Ω -GUS

Organ	35S-GUS			E12 Ω GUS		
	Stage of germination			Stage of germination		
	1 ^a	2 ^b	3 ^c	1	2	3
Cotyledon	++	++	+	++	++	+
Hypocotyl	++	—	+—	++	—	—
Transitional region between shoot and root	+	+	+—	++	++	+
Lateral root primordium	/	/	+—	/	/	+—
Stele of seminal root	/	+	+	/	++	+
Epidermis and root hair of seminal root	±	+—	+—	++	++	++
Root apical meristem	±	±	++	+	+	++
Root cap	+	—	+—	+	++	++

^a Stage 1: seed coat has broken and radicle is extending. Days after imbibition (DAI) 2–3.

^b Stage 2: radicle is elongating and cotyledons are extending from seed coat. (DAI 4).

^c Stage 3: seed coat is dropping off and hypocotyl is extending from the transitional region between the shoot and the root (DAI 5–7). +—, GUS activity was detected in some plants; ±, faint GUS activity was observed; +, GUS activity was observed; ++, strong GUS activity was observed; —, no activity was detected; /, unable to observe the organ in this stage.

of the shoot apex (C, D) and flowers (E, F) 4 days before flowering, in pollen (G, H), in roots (I, J) and in seedlings (K, L) of transgenic tobacco plants that contained 35S-GUS (pBI121; A, C, E, G, I, K) and E12 Ω -GUS (pE2113-GUS; B, D, F, H, J, L). The levels of GUS activity in plants with E12 Ω -GUS were much higher than those in plants with 35S-GUS in all organs and tissues examined. This result is consistent with the results obtained by fluorometric determinations of GUS activity in transient and stable expression assays (Table 1 and Fig. 2).

In leaf blades of 35S-GUS and E12 Ω -GUS plants, strong GUS activity was detected in the palisade, spongy and epidermal cells (A, B). In longitudinal sections of shoot apices, strong staining was observed around vascular bundles in both 35S-GUS plants and E12 Ω -GUS plants (C, D), and blue staining was also detected around apical meristems in E12 Ω -GUS plants. In flower sections, GUS activity was observed only in some parts of the pistil and placenta of pBI121 plants, while strong GUS activity was observed in most parts of flowers of E12 Ω -GUS plants (E, F). Pollen of E12 Ω -GUS plants expressed high-level GUS activity, but pollen of 35S-GUS plants did not (G, H). While strong staining was observed in the central cylinder of roots in both types of plant, the level of GUS activity in E12 Ω -GUS plants was much higher than that in 35S-GUS plants (I, J). In seedlings of 35S-GUS plants, weak activity was observed in the transition regions between shoots and roots, and between the root apical meristem and the root cap (K). In E12 Ω -GUS plants, GUS activity was quite strong in roots and cotyledons (L).

The pattern of expression of GUS activity in tobacco seedlings at various developmental stages was also analyzed [Table 2 and Fig. 4 (K, L)]. In most organs, staining for

GUS was stronger in tissues of E12 Ω -GUS plants than in those of 35S-GUS plants. However, as shown in Table 2, the patterns of staining in the various organs were very similar in the 35S-GUS plants and E12 Ω -GUS plants.

To further evaluate the promoter activities, the gene for LUC was used instead of the gene for GUS. Fusions with the LUC gene (pBE2113-LUC and pBI121-LUC, see Fig. 1) were introduced into tobacco plants. The leaves of transformants of 30 cm in height were detached and luciferin was absorbed through petioles. Among 17 transformants that carried a construct with a strong promoter (pBE2113; E12 Ω), seven plants exhibited strong autofluorescence and another seven plants fluoresced weakly. The light emitted by the leaves was easily detected by the naked eye in a dark room. In the case of 35S-LUC plants, only four out of eleven transformants showed faint autofluorescence. Typical 35S-LUC and E12 Ω -LUC plants that exhibited the strongest autofluorescence are contrasted in Figure 4 (M).

Discussion

We constructed a series of promoter cassettes by combining enhancers of the 35S promoter, an intron, and the Ω sequence to stimulate the expression of foreign genes in rice and tobacco. Studies of transient and stable expression demonstrated that all the cassettes could function efficiently in both tobacco and rice plants. Compared with the CaMV 35S promoter in pBI221, the strongest promoters were 26 and 76 times stronger in terms of the enhancement of levels of the marker protein in tobacco and rice protoplasts, respectively. The most efficient promoters in tobacco cells were not the same as those in rice cells, suggesting differences in the specificity of gene expression between

plant species and/or between dicotyledonous and monocotyledonous plants.

The CaMV 35S promoter is known to function in many organs of many higher plants (Benfey and Chua 1990, Terada et al. 1990, Yang and Christou 1990). Enhancer-like elements are located in the 5'-upstream region of the promoter (Odell et al. 1988, Fang et al. 1989), and tandem duplication of sequences enhances gene expression (Kay et al. 1987, Timmermans et al. 1990, Omirulleh et al. 1993). Hirochika et al. (in preparation) showed that one sequence (-290 to -90) of the 35S promoter was more effective than a longer sequence (-390 to -90) that included the shorter sequence in inducing high-level expression of CAT gene fusions in rice cells. CAT activity increased with the number of each sequence, reaching a maximum with seven tandem repeats. In the current study, seven repeats of the shorter 200-bp fragment were more effective than four and six repeats of the longer sequence (-390 to -90, En) and two repeats of the longer sequence (-419 to -90, El2) in rice cells. In tobacco cells, however, the seven repeats of the shorter 200-bp sequence were not as effective as the other two longer sequences (Table 1). This variable response to the enhancer sequences in different plant species suggests that differences exist in the transcriptional machinery, which includes specific *trans*-acting factors in individual organs. It is known that the 35S promoter has multiple *cis* elements in its 5'-upstream region (Kawata et al. 1989, Lam and Chua 1989, Yanagisawa and Izui 1992). Combinations of these elements may have different effects in different tissues, organs and plant species (Fang et al. 1989, Benfey and Chua 1990).

Some introns are known to increase the level of gene expression in animals and plants. This phenomenon is presumed to be due to an increase in the stability of mRNA, although this phenomenon is not clear in dicot plants (McElroy et al. 1991, Leon et al. 1991), perhaps because of differences in splicing efficiency between monocotyledonous and dicotyledonous plants (Keith and Chua 1986, Tanaka et al. 1990). In this study, higher GUS activity was clearly evident when we included the first intron of the gene for phaseolin in rice and sometimes in tobacco, confirming that the intron effectively enhanced the synthesis of products of a foreign gene, at least in rice plants.

The terminator in chimeric genes also plays an important role in the control of the level of gene expression by affecting the efficiency of the 3'-processing and/or the stability of mRNA (Ingelbrecht et al. 1989). In this study, it was revealed that 3'-untranslated region of the CaMV 35S transcript was more effective for higher-level expression than the terminator of the gene for nopaline synthase in the Ti plasmid. This observation indicates that selection of the terminator is also important for expression of a foreign gene.

The Ω sequence of TMV can increase the amount of a

gene product in plant and animal cells, and even in *E. coli* (Sleat et al. 1987, Gallie et al. 1989, 1991). In the present study, constructs containing this sequence yielded 2 to 4 times higher GUS activity in tobacco and 3 to 5 times higher GUS activity in rice than constructs without this sequence. Because the positive effect of the Ω sequence is exerted at the translational level, the mechanism of action of this element in enhanced gene expression is probably independent of that of enhancers or introns.

The elements tested in this study might function at different steps in gene expression. Thus, all the elements, when combined, should enhance gene expression in an additive manner. Our current results that all elements enhanced expression of a reporter gene in every combination, with the exception of one case of the intron in tobacco cells (pE7131-GUS vs. pE7111-GUS), strongly support such postulate.

Among the four promoter constructs which were extraordinarily active (more than 20 times more active than 35S-GUS) in tobacco protoplasts, one construct, El2 Ω , was selected together with the moderately strong promoter E7 Ω (8.6 times more active) for stable transformation experiments. The levels of GUS activity in El2 Ω -GUS plants and E7 Ω -GUS plants were 10-fold and 3-fold higher than those in 35S-GUS plants, respectively, suggesting that the activity of a promoter in transient assays reflects its activity in transgenic plants. Histochemical analysis showed that tissue- and organ-specific expression of these promoters was very similar to that of 35S-GUS.

In the experiments with rice protoplasts, we selected two promoter constructs, pE7133 and pE7113, for generation of stable transformants. The former is a representative construct with seven repetitions of the shortest enhancer, the Ω sequence, and the intron, and it was associated with the highest level of expression (about 70 times higher than that of 35S-GUS). Transgenic calli that harbored pE7133-GUS and pE7133-LUC had the highest levels of GUS and LUC activities (data not shown), but the calli were not easy to maintain and it was hard to regenerate whole plants from them. It is possible that the negative result reflects some physiological stress caused by too large an amount of the foreign gene product. We obtained transgenic rice plants that harbored E7 Ω -GUS with moderately high-level expression in rice protoplasts. On average, the GUS activity obtained with E7 Ω -GUS was 14 times higher than that obtained with 35S-GUS. Although E7 Ω was not the strongest expression promoter in rice protoplasts, the level of expression of the GUS gene in stable transformants that harbored E7 Ω -GUS was one order higher than that with 35S-GUS.

For convenient comparisons, the effect of each element in stimulating promoter activity in tobacco and rice is summarized in Table 3.

The copy number of integrated genes might also affect

Table 3 Strength of each element as part of the promoter in the regulation of gene expression

	Element in promoter					Terminator	
	E7	En4 or En6	E12	In	Ω	Tnos	T35S
Tobacco	+	++	++	±	+	+	++
Rice	++	+	+	++	+	+	++

±, stimulatory effect was observed in some constructs; +, stimulatory effect was observed in all constructs; ++, strong stimulatory effect was observed in all constructs.

the level of expression in transgenic plants. In this study, in about two-thirds of the self-pollinated progeny of each E12 Ω -GUS transgenic tobacco plant, the transgene was introduced at a single locus, as judged by the segregation of resistance to kanamycin. This fraction is similar to that for 35S-GUS plants.

The CaMV 35S promoter has often been used as a strong and constitutive promoter of the expression of many foreign genes for the production of transgenic plants in many plant species. Indeed, many experiments have shown that the 35S promoter is useful as a strong promoter for the expression of sense and antisense genes. However, in some cases, stronger promoters have been required to achieve higher levels of gene products. The powerful promoter cassettes reported here were 20- to 80-fold and 10-fold stronger than the 35S promoter in protoplasts and in transgenic plants, respectively. Using the powerful promoter E12 Ω , we have obtained many kinds of useful transgenic plant, for example, virus-resistant plants with a gene for the coat protein of a potyvirus (bean yellow mosaic virus; Nakamura et al. 1994) and a antisense RNA gene of cucumber mosaic virus with and without ribozyme sequences (Nakamura et al. 1995). Another example is a transgenic plant with high-level production of asparagine (Kan et al., in preparation). Thus, these promoters are potentially useful for the production of at least 10-fold higher amounts of foreign gene products in transgenic plants both for basic studies of problems in plant molecular biology and for practical purposes. We can see the improved efficiency of a promoter for gene expression in Figure 4, in particular in the photograph of the autofluorescence of the transgenic tobacco plant with the strong promoter (Fig. 4M). Unique restriction sites located at the ends of each part of the promoters allow convenient replacement of any part of the chimeric genes by other sequences. Therefore, our effective promoter cassettes should also be useful for the analysis of the effects of given sequences on gene expression and also for the development of even more effective new cassettes.

We are grateful to Prof. J. Messing and Dr. A. Kato for providing the plasmids pFF19G and pUC19HPT, respectively, and to Dr. S. Kosugi for helpful discussion. This work was supported in part by a project grant from the Japanese Ministry of Agriculture, Forestry and Fisheries.

References

- Beachy, R.N., Loesh-Fries, S. and Tumer, N.E. (1990) Coat protein-mediated resistance against virus infection. *Annu. Rev. Phytopathol.* 28: 451-474.
- Benfey, P.N. and Chua, N-H. (1990) The cauliflower mosaic virus 35S promoter: combinational regulation of transcription in plants. *Science* 250: 959-966.
- Bevan, M., Branes, W.M. and Chilton, M-D. (1983) Structure and transcription of the nopaline synthase gene region of T-DNA. *Nucl. Acids Res.* 11: 369-385.
- Buchman, A.R. and Berg, P. (1988) Comparison of intron-dependent and intron-independent gene expression. *Mol. Cell. Biol.* 8: 4395-4405.
- Callis, J., Fromm, M. and Walbot, V. (1987) Introns increase gene expression in cultured maize cells. *Genes Dev.* 1: 1183-1200.
- Clancy, M., Vasil, V., Hannah, L.C. and Vasil, I.K. (1994) Maize *shrunken-1* intron and exon region increase gene expression in maize protoplasts. *Plant Sci.* 98: 151-161.
- Fang, R-X., Nagy, F., Sivasubramaniam, S. and Chua, H-N. (1989) Multiple *cis* regulatory elements for maximal expression of the cauliflower mosaic virus 35S promoter in transgenic plants. *Plant Cell* 1: 141-150.
- Gallie, D.R., Feder, J.N., Schimke, R.T. and Walbot, V. (1991) Post-transcriptional regulation in higher eukaryotes: the role of the reporter gene in controlling expression. *Mol. Gen. Genet.* 228: 258-264.
- Gallie, D.R., Lucas, W.J. and Walbot, V. (1989) Visualizing mRNA expression in plant protoplasts: factors influencing efficient mRNA uptake and translation. *Plant Cell* 1: 301-311.
- Gamborg, O.L., Miller, R.A. and Ojima, K. (1968) Nutrient requirements of suspension cultures of soybean root cells. *Exp. Cell. Res.* 50: 151-158.
- Gruss, P. and Khoury, G. (1980) Rescue of a splicing defective mutant by insertion of a heterologous intron. *Nature* 286: 634-637.
- Hennig, W., Nover, L. and Scheer, U. (1994) *Plant Promoters and Transcription Factors*. Springer-Verlag, Berlin.
- Higuchi, R. (1989) Using PCR to engineer DNA. In PCR Technology. Edited by Erlich, H.A. pp. 61-70. Stockton Press, New York.
- Horsch, R.B., Fry, J.E., Hoffmann, N.L., Eichholtz, D., Rogers, S.G. and Fraley, R.T. (1985) A simple and general method for transferring genes into plants. *Science* 227: 1229-1231.
- Huang, M.T.F. and Gorman, C.M. (1990) Intervening sequences increase efficiency of RNA 3' processing and accumulation of cytoplasmic RNA. *Nucl. Acids Res.* 18: 937-947.
- Ingelbrecht, I.L.W., Herman, L.M.F., Dekeyser, R.A., Van Montagu, M.C. and Depicker, A.G. (1989) Different 3' end regions strongly influence the level of gene expression in plant cells. *Plant Cell* 1: 671-680.
- Jefferson, R.A., Kavanagh, T.A. and Bevan, M.W. (1987) GUS fusions: β -glucuronidase as a sensitive and versatile gene fusion marker in higher plants. *EMBO J.* 6: 3901-3907.

- Kawata, T., Nakatuka, A., Tabata, T. and Iwabuchi, M. (1989) Function of the hexameric sequence in the cauliflower mosaic virus 35S RNA promoter region. *Biochem. Biophys. Res. Commun.* 164: 387–393.
- Kay, R., Chan, A., Daly, M. and McPherson, J. (1987) Duplication of CaMV 35S promoter sequence creates a strong enhancer for plant genes. *Science* 236: 1299–1302.
- Keith, B. and Chua, N-H. (1986) Monocot and dicot pre-mRNAs are processed with different efficiencies in transgenic tobacco. *EMBO J.* 5: 2419–2425.
- Kosugi, S., Ohashi, Y., Nakajima, K. and Arai, Y. (1990) An improved assay for β -glucuronidase in transformed cells: methanol almost completely suppresses a putative endogenous β -glucuronidase activity. *Plant Sci.* 70: 133–140.
- Lam, E. and Chua, N-H. (1989) ASF-2: a factor that binds to the cauliflower mosaic virus 35S promoter and a conserved GATA motif in *Cab* promoters. *Plant Cell* 1: 1147–1156.
- Leon, P., Planckaert, F. and Walbot, V. (1991) Transient gene expression in protoplasts of *Phaseolus vulgaris* isolated from a cell suspension culture. *Plant Physiol.* 95: 968–972.
- Maniatis, T., Fritsh, E.F. and Sambrook, J. (1982) *Molecular Cloning*. Cold Spring Harbor Laboratory, Cold Spring Harbor, New York.
- McElroy, D., Blowers, A.D., Jenes, B. and Wu, R. (1991) Construction of expression vectors based on the rice actin 1 (Act1) 5' region for use in monocot transformation. *Mol. Gen. Genet.* 231: 150–160.
- McElroy, D., Zhang, W., Cao, J. and Wu, R. (1990) Isolation of an efficient actin promoter for use in rice transformation. *Plant Cell* 2: 163–171.
- Müller-Röber, B., Sonnewald, U. and Willmitzer, L. (1992) Inhibition of the ADP-glucose pyrophosphorylase in transgenic potatoes leads to sugar-storing tubers and influences tuber formation and expression of tuber storage protein genes. *EMBO J.* 11: 1229–1238.
- Murashige, T. and Skoog, F. (1962) A revised medium for rapid growth and bioassays with tobacco tissue cultures. *Physiol. Plant.* 15: 473–497.
- Nakamura, S., Honkura, R., Ugaki, M., Ohshima, M. and Ohashi, Y. (1994) Nucleotide sequence of the 3'-terminal region of bean yellow mosaic virus RNA and resistance to viral infection in transgenic *Nicotiana benthamiana* expressing its coat protein gene. *Ann. Phytopathol. Soc. Japan* 60: 295–304.
- Nakamura, S., Honkura, R., Ugaki, M., Ohshima, M. and Ohashi, Y. (1995) Resistance to viral infection in transgenic plants expressing ribozymes designed against cucumber mosaic virus RNA3. *Ann. Phytopathol. Soc. Jpn.* 61: 53–55.
- Nishiguchi, M., Kikuchi, S., Kiho, Y., Ohno, T., Meshi, T. and Okada, Y. (1985) Molecular basis of plant viral virulence; the complete nucleotide sequence of an attenuated strain of tobacco mosaic virus. *Nucl. Acids Res.* 13: 5585–5590.
- Odell, J.T., Knowlton, S., Lin, W. and Mauvais, C.J. (1988) Properties of an isolated transcription stimulating sequence derived from the cauliflower mosaic virus 35S promoter. *Plant Mol. Biol.* 10: 263–272.
- Ohshima, M., Itoh, H., Matsuoka, M., Murakami, T. and Ohashi, Y. (1990) Analysis of stress-induced or salicylic acid-induced expression of the pathogenesis-related 1a protein gene in transgenic tobacco. *Plant Cell* 2: 95–106.
- Omirulleh, S., Ábrahám, M., Golovkin, M., Stefanov, I., Karabaev, M.K., Mustárdy, L., Mórocz, S. and Dudits, D. (1993) Activity of chimeric promoter with the doubled CaMV 35S enhancer element in protoplast-derived cells and transgenic plants in maize. *Plant Mol. Biol.* 21: 415–428.
- Ooms, G., Hooykaas, P.J., Moolenaar, G. and Schilperoort, R.A. (1981) Crown gall plant tumors of abnormal morphology, induced by *Agrobacterium tumefaciens* carrying mutated octopine Ti plasmid; analysis of T-DNA functions. *Gene* 14: 33–50.
- Powell, P.A., Nelson, R.S., De, B., Hoffmann, N., Rogers, S.G., Fraley, R.T. and Beachey, R.N. (1986) Delay of disease development in transgenic plants that express the tobacco mosaic virus coat protein gene. *Science* 232: 738–743.
- Riesmeier, J.W., Willmitzer, L. and Frommer, W.B. (1994) Evidence for an essential role of the sucrose transporter in phloem loading and assimilate partitioning. *EMBO J.* 13: 1–7.
- Sleat, D.E., Gallie, D.R., Jefferson, R.A., Bevan, M.W., Turner, P.C. and Wilson, T.M.A. (1987) Characterisation of the 5'-leader sequence of tobacco mosaic virus RNA as a general enhancer of translation in vitro. *Gene* 217: 217–225.
- Slightom, J.L., Sun, S.M. and Hall, T.C. (1983) Complete nucleotide sequence of a french bean storage protein gene: phaseolin. *Proc. Natl. Acad. Sci. USA* 80: 1897–1901.
- Sugimoto, K., Otsuki, Y., Saji, S. and Hirochika, H. (1994) Transposition of the maize *Ds* element from a viral vector to the rice genome. *Plant J.* 5: 863–871.
- Tanaka, A., Mita, S., Ohta, S., Kyozuka, J., Shimamoto, K. and Nakamura, K. (1990) Enhancement of foreign gene expression by dicot intron in rice but not in tobacco is correlated with an increased level of mRNA and efficient splicing of the intron. *Nucl. Acids Res.* 18: 6767–6770.
- Terada, R. and Shimamoto, K. (1990) Expression of CaMV 35S-GUS gene in transgenic rice plants. *Mol. Gen. Genet.* 220: 389–392.
- Timmermans, M.C.P., Maliga, P., Vieira, J. and Messing, J. (1990) The pFF plasmids: cassettes utilising CaMV sequences for expression of foreign genes in plants. *J. Biotechnol.* 14: 333–344.
- Yanagisawa, S. and Izui, K. (1992) MNF1, a leaf tissue-specific DNA-binding protein of maize, interacts with the cauliflower mosaic virus 35S promoter as well as the C_4 photosynthetic phosphoenolpyruvate carboxylase gene promoter. *Plant Mol. Biol.* 19: 545–553.
- Yang, N-S. and Christou, P. (1990) Cell type specific expression of a CaMV 35S-GUS gene in transgenic soybean plants. *Dev. Genet.* 11: 289–293.

(Received June 9, 1995; Accepted October 30, 1995)

