



## Efficient Shift Registers, LFSR Counters, and Long Pseudo-Random Sequence Generators

XAPP 052 July 7,1996 (Version 1.1)

Application Note by Peter Alfke

### Summary

Shift registers longer than eight bits can be implemented most efficiently in XC4000E Select-RAM™. Using Linear Feedback Shift-Register (LFSR) counters to address the RAM makes the design even simpler. This application note describes 4- and 5-bit universal LFSR counters, very efficient RAM-based 32-bit and 100-bit shift registers, and pseudo-random sequence generators with repetition rates of thousands and even trillions of years, useful for testing and encryption purposes. The appropriate taps for maximum-length LFSR counters of up to 168 bits are listed.

### Xilinx Family

XC4000E, XC4000L, XC4000EX, XC4000XL

### Demonstrates

Shift registers implemented in RAM  
LFSR counters

## Introduction

The XC4000E on-chip distributed synchronous RAM architecture lends itself well to the efficient implementation of long shift registers. The 16 x 1 or 32 x 1 RAM behaves like an edge-triggered register. An address counter supplies sequential addresses, but there is no need for a conventional binary address sequence. Any repetitive pattern is acceptable, and a linear feedback shift register counter is the most efficient. In the examples below the conventional LFSR counter algorithm has been modified to guarantee no lock-up, even in the all-ones state.

Note that the established literature describes the outputs of LFSRs as Q1 to Qn (not Q0 to Qn-1, as is customary in binary counters). In order to be consistent with prior literature, LFSR bits are therefore labeled 1 to n throughout this application note.

## LFSR Counters

For a 4-bit counter, the basic XNOR feedback from Q3 and Q4 would exclude the all-ones state. By decoding the two states where the lower three bits are all ones, and inverting

the feedback for those states, the 4-bit LFSR counter counts modulo 16, and has no lock-up state. Counters with a shorter cycle require additional decoding of the feedback signal, as shown in [Table 1](#) and [Figure 1](#). Any such decoding is easily done in the front-end CLB function generator. For a 5-bit counter, [Table 2](#) shows the connections required for dividing by any number up to 32.

**Table 1: Decoding of Feedback Signal, 4-Bit Counter**

1234		1234	
0000		0110	3
1000	7	0011	11
1100	11	1001	9 & 8
1110		0100	14
1111		1010	6
0111	13 & 12	0101	2
1011	10	0010	5
1101	5 & 4	0001	

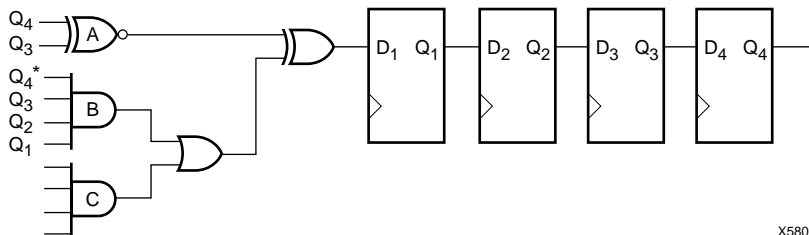

X5801

**Figure 1: Divide by 5 to 16 Counter**

**Table 2: Decoding of Feedback Signal, 5-Bit Counter**

12345		12345	
00000		11101	13
10000	23 & 22	11110	31
11000	7	11111	
11100	19 & 18	01111	15 & 14
01110	17	10111	29
00111	8	11011	6 & 5
10011	12	01101	26
01001	28 & 27	10110	3
00100	15	01011	11 & 10
00010	11	00101	17 & 16
10001	9	10010	20
01000	4	11001	25
10100	30	01100	6
01010	21	00110	24
10101	2	00011	21
11010	26	00001	31

**Divide-By 5 to 16 Counter in Two CLBs**

Feedback for ÷16:  
 (Q3 XNOR Q4) XOR (Q1 AND Q2 AND Q3)

To divide by a number smaller than 15, use AND gate “C” in Figure 1 to decode the binary pattern listed in Table 1 next to the desired number. For ÷ 15 and any number listed to

the right of the & symbol, also add Q4 to AND gate “B”, thus skipping the all-ones state. All of these counters avoid lock-up in the all-ones state.

- For ÷ 16: do not connect Q4 to AND gate “B”, do not use AND gate “C”
- For ÷ 15: connect Q4 to AND gate “B”, do not use AND gate “C”
- For ÷ <15: program AND gate “C” according to the table
- For ÷ 4, 8,12,15: connect Q4 to AND gate “B”
- For all other numbers: do not connect Q4 to AND gate “B”

**Divide-By 2 to 32 Counter in 2.5 CLBs**

Feedback for ÷32:  
 (Q3 XNOR Q5) XOR (Q1 AND Q2 AND Q3 AND Q4)

To divide by a number smaller than 31, use AND gate “C” in Figure 2 to decode the binary pattern listed in Table 2 next to the desired number. For ÷ 31 and any number listed to the right of the & symbol, also add Q5 to AND gate “B”, thus skipping the all-ones state. All of these counters avoid lock-up in the all-ones state.

- For ÷ 32: do not connect Q5 to AND gate “B”, do not use AND gate “C”
- For ÷ 31: connect Q5 to AND gate “B”, do not use AND gate “C”
- For ÷ <31: program AND gate “C” according to the table
- For ÷ 5,10,14,16,18, 22, 27, 31: connect Q5 to AND gate “B”
- For all other numbers: do not connect Q5 to AND gate “B”

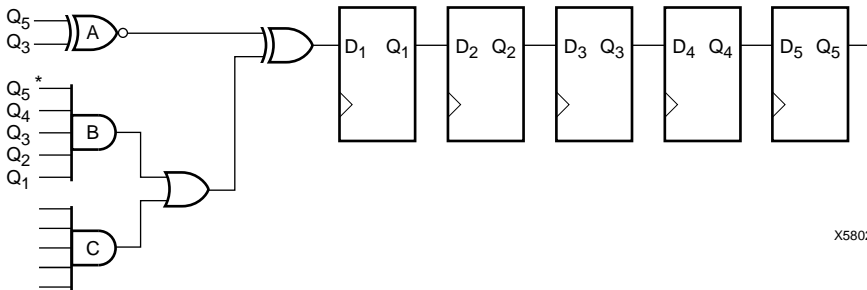

X5802

**Figure 2: Divide by 2 to 32 Counter**

## RAM-Based Shift Registers

As shown in **Figure 3**, a 32 x 1 shift register design requires two CLBs for the + 16 address counter plus one CLB for the RAM. An 8-bit wide, 32-bit long shift register would use seven additional CLBs for RAM storage and output registers. Wider and longer shift registers can easily be implemented using the same concept. For increased length, it is most efficient to divide the length into equal parts of up to 16 bits each and use a common address counter.

**Figure 4** shows a 100-bit long, 8-bit wide shift register as an example. It uses two CLBs to implement a divide-by-16 counter, plus 24 CLBs for RAM storage and additional registers. Each bitstream uses three cascaded CLBs with their RAMs acting as 16+16 bit registers, plus four of their flip-flops used to bring the total shift-register length to 100. This design thus emulates 800 bits of shift register in only 26 CLBs, and it can run at a 70 MHz clock rate. Traditional register-based designs would use 5,600 equivalent gates for this complete function (seven gates per register bit). Here it occupies 6.5% of an XC4010E. Does that qualify the XC4010E as an 86,000 gate device?

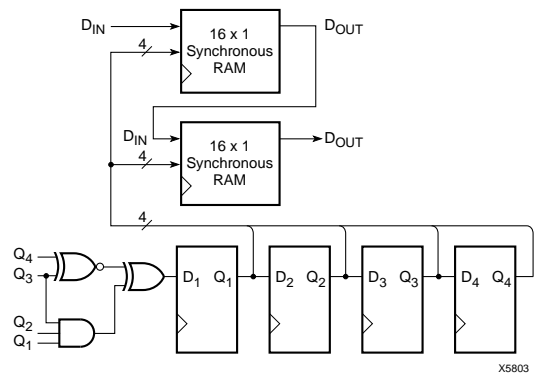

**Figure 3: 32 x 1 Shift Register in 3 CLBs**

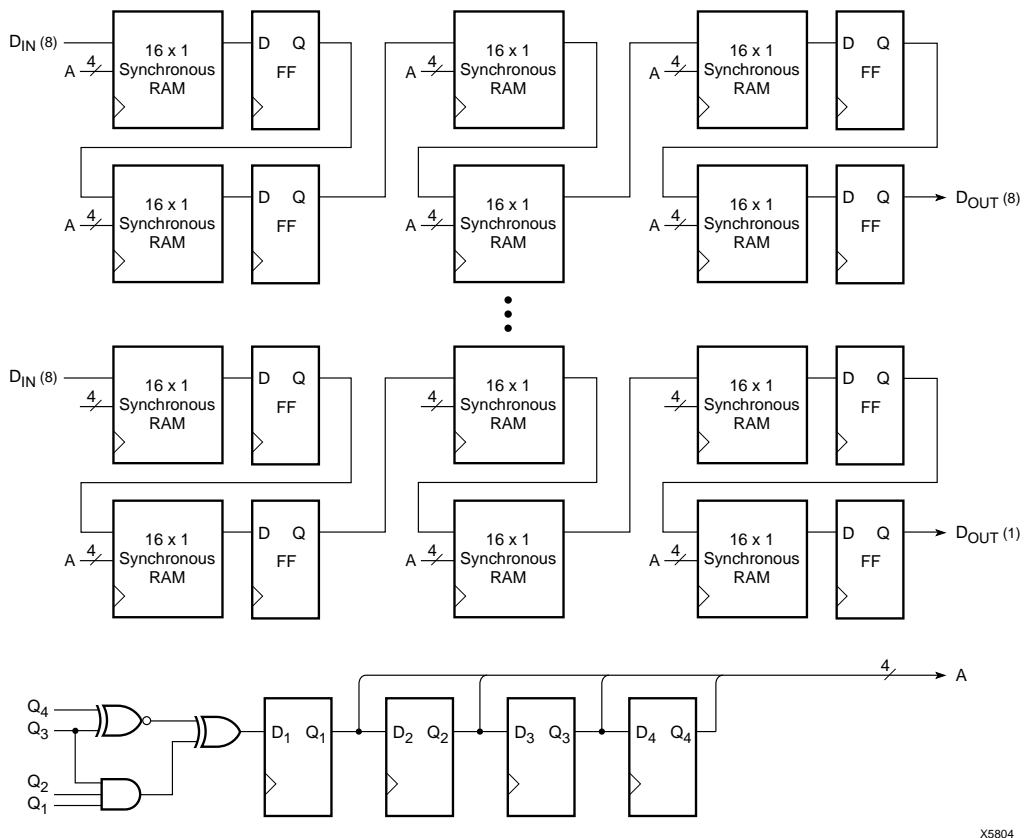

**Figure 4: 100 x 8 Shift Register in 26 CLBs**



## Linear Feedback Shift Register Taps

This table lists the appropriate taps for maximum-length LFSR counters of up to 168 bits. The basic description and the table for the first 40 bits was originally published in XCELL and reprinted on page 9-24 of the 1993 and 1994 Xilinx Data Books.

Responding to repeated requests, the list is here extended to 168 bits. This information is based on unpublished research done by Wayne Stahnke while he was at Fairchild Semiconductor in 1970.

**Table 3: Taps for Maximum-Length LFSR Counters**

n	XNOR from	n	XNOR from	n	XNOR from	n	XNOR from
3	3,2	45	45,44,42,41	87	87,74	129	129,124
4	4,3	46	46,45,26,25	88	88,87,17,16	130	130,127
5	5,3	47	47,42	89	89,51	131	131,130,84,83
6	6,5	48	48,47,21,20	90	90,89,72,71	132	132,103
7	7,6	49	49,40	91	91,90,8,7	133	133,132,82,81
8	8,6,5,4	50	50,49,24,23	92	92,91,80,79	134	134,77
9	9,5	51	51,50,36,35	93	93,91	135	135,124
10	10,7	52	52,49	94	94,73	136	136,135,11,10
11	11,9	53	53,52,38,37	95	95,84	137	137,116
12	12,6,4,1	54	54,53,18,17	96	96,94,49,47	138	138,137,131,130
13	13,4,3,1	55	55,31	97	97,91	139	139,136,134,131
14	14,5,3,1	56	56,55,35,34	98	98,87	140	140,111
15	15,14	57	57,50	99	99,97,54,52	141	141,140,110,109
16	16,15,13,4	58	58,39	100	100,63	142	142,121
17	17,14	59	59,58,38,37	101	101,100,95,94	143	143,142,123,122
18	18,11	60	60,59	102	102,101,36,35	144	144,143,75,74
19	19,6,2,1	61	61,60,46,45	103	103,94	145	145,93
20	20,17	62	62,61,6,5	104	104,103,94,93	146	146,145,87,86
21	21,19	63	63,62	105	105,89	147	147,146,110,109
22	22,21	64	64,63,61,60	106	106,91	148	148,121
23	23,18	65	65,47	107	107,105,44,42	149	149,148,40,39
24	24,23,22,17	66	66,65,57,56	108	108,77	150	150,97
25	25,22	67	67,66,58,57	109	109,108,103,102	151	151,148
26	26,6,2,1	68	68,59	110	110,109,98,97	152	152,151,87,86
27	27,5,2,1	69	69,67,42,40	111	111,101	153	153,152
28	28,25	70	70,69,55,54	112	112,110,69,67	154	154,152,27,25
29	29,27	71	71,65	113	113,104	155	155,154,124,123
30	30,6,4,1	72	72,66,25,19	114	114,113,33,32	156	156,155,41,40
31	31,28	73	73,48	115	115,114,101,100	157	157,156,131,130
32	32,22,2,1	74	74,73,59,58	116	116,115,46,45	158	158,157,132,131
33	33,20	75	75,74,65,64	117	117,115,99,97	159	159,128
34	34,27,2,1	76	76,75,41,40	118	118,85	160	160,159,142,141
35	35,33	77	77,76,47,46	119	119,111	161	161,143
36	36,25	78	78,77,59,58	120	120,113,9,2	162	162,161,75,74
37	37,5,4,3,2,1	79	79,70	121	121,103	163	163,162,104,103
38	38,6,5,1	80	80,79,43,42	122	122,121,63,62	164	164,163,151,150
39	39,35	81	81,77	123	123,121	165	165,164,135,134
40	40,38,21,19	82	82,79,47,44	124	124,87	166	166,165,128,127
41	41,38	83	83,82,38,37	125	125,124,18,17	167	167,161
42	42,41,20,19	84	84,71	126	126,125,90,89	168	168,166,153,151
43	43,42,38,37	85	85,84,58,57	127	127,126		
44	44,43,18,17	86	86,85,74,73	128	128,126,101,99		

## LFSR Counters, 3 to 168 Bits

Conventional binary counters use complex or wide fan-in logic to generate high end carry signals. A much simpler structure sacrifices the binary count sequence, but achieves very high speed with very simple logic, easily packing two bits into every CLB. Such Linear Feedback Shift-Register (LFSR) counters are also known as pseudo-random sequence generators.

An n-bit LFSR counter can have a maximum sequence length of  $2^n - 1$ . In that case, it goes through all possible code permutations except one, which would be a lock-up state. A maximum length n-bit LFSR counter consists of an n-bit shift register with an XNOR in the feedback path from the last output  $Q_n$  to the first input  $D_1$ . The XNOR makes the lock-up state the all-ones state; an XOR would make it the all-zeros state. For normal Xilinx applications, all-ones is more easily avoided, since "by default" the flip-flops wake up in the all-zeros state. Table 3 describes the outputs that must be used as inputs of the XNOR. LFSR outputs are traditionally labeled 1 through n, with 1 being the first stage of the shift register, and n being the last stage. This is different from the conventional 0 to (n-1) notation for binary counters. A multi-input XNOR is also known as an even-parity circuit. Note that the connections described in this table are not necessarily unique; certain other connections may also result in maximum length sequences.

### Examples

- A 10-bit shift register counts modulo 1023, if the input  $D_1$  is driven by the XNOR of  $Q_{10}$  and the bit three positions to the left ( $Q_7$ ), i.e. a one is shifted into  $D_1$  when  $Q_{10}$  and  $Q_7$  have even parity, which means they are identical.
- An 8-bit shift register counts modulo 255 if the input  $D_1$  is driven by the XNOR of  $Q_8$ ,  $Q_6$ ,  $Q_5$ ,  $Q_4$ , i.e., a one is shifted into  $D_1$  if these four outputs have even parity, (four zeros, or two ones, or four ones).

## References:

Wayne Stahnke, *Primitive Polynomials Modulo Two*, private communication in 1970, giving the following references:

E.R. Berlekamp, *Algebraic Coding Theory*, McGraw-Hill, 1968

P.H.R. Scholefield, *Shift Registers Generating Maximum-Length Sequences*, Electronic Technology, 10-1960, pp. 389-394

S.W. Golomb, *Shift Register Sequences*, Holden-Day, San Francisco, 1967

E.J. Watson, *Primitive Polynomials (Mod 2)*, Math. Comp. v.16 pp. 368, 1962

N. Zierler and J. Brillhart, *On Primitive Trinomials*, Information and Control v. 13, pp 541-554, 1968, and v. 14, pp. 566-569, 1969

R.W. Marsh, *Table of Irreducible Polynomials*, Dept. of Commerce, October 1957

H. Riesel, *En Bok om Primtal*, Studentlitteratur, Denmark, 1968

M. Kraitchik, *Théorie des Nombres*, Gauthier-Villars, Paris, 1922 and 1952

M. Kraitchik, *On the Factorization of  $2^n \pm 1$* , Scripta Mathematica, v. 18, pp. 39-52, 1952

J. Brillhart, *Miscellaneous Factorizations*, Math. Comp., v. 17 pp. 447-450, 1963

J. Brillhart and J.L.Selridge, *Factorizations...*, Math. Comp., v. 21, pp. 87-96, 1967

K.R. Isemonger, *Additional Factorizations...*, Math. Comp., v. 19, pp. 145-146, 1965

R.M. Robinson, *Some Factorizations...*, Math. Comp., v. 11, pp. 265-268, 1957



### Headquarters

Xilinx, Inc.  
2100 Logic Drive  
San Jose, CA 95124  
U.S.A.

Tel: 1 (800) 255-7778  
or 1 (408) 559-7778  
Fax: 1 (800) 559-7114

Net: hotline@xilinx.com  
Web: http://www.xilinx.com

© 1996 Xilinx, Inc. All rights reserved. The Xilinx name and the Xilinx logo are registered trademarks, all XC-designated products are trademarks, and the Programmable Logic Company is a service mark of Xilinx, Inc. All other trademarks and registered trademarks are the property of their respective owners.

Xilinx, Inc. does not assume any liability arising out of the application or use of any product described herein; nor does it convey any license under its patent, copyright or maskwork rights or any rights of others. Xilinx, Inc. reserves the right to make changes, at any time, in order to improve reliability, function or design and to supply the best product possible. Xilinx, Inc. cannot assume responsibility for the use of any circuitry described other than circuitry entirely embodied in its products. Products are manufactured under one or more of the following U.S. Patents: (4,847,612; 5,012,135; 4,967,107; 5,023,606; 4,940,909; 5,028,821; 4,870,302; 4,706,216; 4,758,985; 4,642,487; 4,695,740; 4,713,557; 4,750,155; 4,821,233; 4,746,822; 4,820,937; 4,783,607; 4,855,669; 5,047,710; 5,068,603; 4,855,619; 4,835,418; and 4,902,910. Xilinx, Inc. cannot assume responsibility for any circuits shown nor represent that they are free from patent infringement or of any other third party right. Xilinx, Inc. assumes no obligation to correct any errors contained herein or to advise any user of this text of any correction if such be made.