

**ELECTRONIC PROCUREMENT AND ORGANIZATIONAL  
PERFORMANCE AMONG COMMERCIAL STATE  
CORPORATIONS**

**BY**

**ABDI KASSIM AMIN**

**D61/73401/2009**

**SUPERVISOR**

**MICHAEL K. CHIRCHIR**

**A RESEARCH PROJECT PRESENTED IN PARTIAL FULFILLMENT  
OF THE REQUIREMENTS FOR THE AWARD OF MASTER OF  
BUSINESS ADMINISTRATION, SCHOOL OF BUSINESS OF THE  
UNIVERSITY OF NAIROBI**

**2012**

## **DECLARATION**

I declare that this research project is my original work and has never been submitted to any other University for assessment or award of a degree.

Signature..... Date.....

Abdi Kassim Amin

This project has been submitted with our authority as the university supervisors.

Signature..... Date .....

Michael K. Chirchir

Supervisor

## **DEDICATION**

This research is dedicated to my Parents Mr.Kassim Amin and Mrs Rukia Abdullahi,Bishara Kassim my lovely sister, Qamar Mohamed my lovely wife and my uncle Mohamed .K. Mohamud you really inspired me to achieve my goals. God bless you all.

## ACKNOWLEDGEMENT

I would like to extend my gratitude to almighty God for seeing me through. I sincerely acknowledge my supervisor Mr. Michael K Chirchir, Lecturer at the University of Nairobi for his enabling support and guidance.

## **TABLE OF CONTENTS**

DECLARATION.....	ii
DEDICATION.....	iii
ACKNOWLEDGEMENT.....	iv
LIST OF TABLES.....	vii
LIST OF FIGURES.....	viii
ABSTRACT .....	ix
CHAPTER ONE: INTRODUCTION .....	1
1.1 Background of the Study.....	1
1.1.1 Procurement.....	2
1.1.2 E-procurement .....	3
1.1.3 Organizational Performance .....	4
1.1.4 Commercial State Corporations in Kenya.....	6
1.2 Statement of the Problem .....	8
1.3 Research Objectives .....	9
1.4 Value of the Study.....	10
CHAPTER TWO: LITERATURE REVIEW.....	11
2.0 Introduction .....	11
2.1 The Role of e-procurement.....	11
2.2 E-procurement and organizational performance .....	15
2.3 Summary and research gaps .....	19
2.4 Conceptual Framework and Research Gaps.....	19
CHAPTER THREE: RESEARCH METHODOLOGY .....	21
3.1 Introduction .....	21
3.2 Research Design .....	21

3.3 The Population.....	21
3.4 The Sample .....	22
3.5 Data Collection .....	22
3.6 Data Analysis and Reporting.....	22
<b>CHAPTER FOUR: DATA ANALYSIS, FINDINGS AND INTERPRETATIONS.....</b>	<b>24</b>
4.1 Introduction .....	24
4.2 Organizational profile.....	24
4.3 Adoption of e-procurement .....	26
4.4 Effects of e-procurement on performance of commercial state corporations in Kenya.....	31
4.5 Regression Analysis .....	36
<b>CHAPTER FIVE: SUMMARY OF FINDINGS, CONCLUSIONS AND RECOMMENDATIONS.....</b>	<b>39</b>
5.1 Introduction .....	39
5.2 Summary of Findings .....	39
5.3 Conclusions .....	41
5.4 Recommendations .....	41
5.5 Limitations of the study.....	42
5.6 Suggestions for Further Research.....	43
<b>REFERENCES .....</b>	<b>44</b>
Appendix I: Research Questionnaire.....	48

## LIST OF TABLES

Table 4.1: Adoption of e-procurement.....	24
Table 4.2: Tenders are advertised online .....	26
Table 4.3: Short listing of tenders is done by the e-procurement system .....	27
Table 4.4: Specifications for procured items are posted to company website .....	29
Table 4.5: All company staff makes requisitions online.....	29
Table 4.6: Enables the organization to streamline processes.....	32
Table 4.7: Improves transparency in the procurement process.....	34
Table 4.8: Leads to competitive bidding and sourcing .....	35
Table 4.9: Encourages accountability .....	36
Table 4.10: Model Summary <sup>b</sup> .....	37
Table 4.11: Coefficients .....	38

## **LIST OF FIGURES**

Figure 4.1: Years that have elapsed since adopting e-procurement.....	25
Figure 4.2: Success of the adoption process .....	25
Figure 4.3: Suppliers submit proposals online.....	27
Figure 4.4: Functioning website to facilitate e-procurement .....	28
Figure 4.5: Call for proposals is done through the company website .....	30
Figure 4.6: Leads to cost reduction .....	31
Figure 4.7: Leads to better service delivery .....	32
Figure 4.8: Facilitates real time response to customers .....	33
Figure 4.9: Guarantees real time response to the market .....	34
Figure 4.10: Improves the flow of information.....	35



## **ABSTRACT**

Driven by the increasing trend toward purchasing inputs and other raw materials from outside the organization, implementing electronic procurement has become a significant tactic in most companies. A study was conducted on electronic procurement and organizational performance among commercial state corporations in Kenya. The study aimed to achieve two objectives: To establish the extent to which state corporations have adopted e-procurement and to find the effects of e-procurement on the performance of commercial state corporations in Kenya.

The study adopted a descriptive research design where a sample size of 40 respondents who were selected through stratified sampling was involved in the study. Primary data was collected from supply chain officers by use of a questionnaire. The data was analyzed and presented in tables, pie charts and histograms. A regression was also conducted to establish the relationship between e-procurement and performance.

The findings indicate that commercial state corporations in Kenya have adopted e-procurement but there are several functions they still perform manually. These include, short listing of suppliers, call for proposals and tendering process. It was also established that e-procurement has led to cost reduction, improved transparency, and accountability among others. The study encountered limitations such inadequate time and finances to exhaust all the aspects of electronic procurement and organizational performance well as uncooperative respondents who were unwilling to fill the questionnaires due to the high degree of confidentiality required among the state corporations in Kenya.

# CHAPTER ONE: INTRODUCTION

## 1.1 Background of the Study

The arrival of the Internet as a means of doing business has served as a medium for major changes in the operation and status of organizational procurement. It is evident that Information Technologies have totally transformed the way organizations and governments operate(Nelson *et.al.*,2001). They further assert that, majority of organizational expenses consists of money used to purchase various products and services. In order to decrease the total costs spent on purchasing process, internet technologies are used and E-Procurement has become popular to implement in the latest era by both governments and enterprises. Although the opportunities for improvement seem to flourish, both private and public sector organizations are still guarded as far as the adoption of electronic technologies is concerned (Zheng, et al. 2004).

Some of the electronic technologies that have revolutionalized business include the e-procurement. There has been growing interest in the adoption of e-procurement by private and public sector organizations in the last decade. However, this interest has been with many reservations since e-procurement is a recent phenomenon. (Dai & Kauffman, 2001; Koorn, Smith & Mueller, 2001), there is no doubt that the use of the Internet in e-Procurement provides several advantages over earlier inter-organizational tools. For example, Electronic Data Interchange has been providing automated purchasing transactions between buyers and their suppliers since it was launched in the 1960s. Enterprise Resource Planning (ERP) followed in the 1970s, and then came the commercial use of the Internet in 1980s. This was

followed by the universal application of the World Wide Web in the 1990s (Office of Government Commerce, 2002).

According to the Epiq Technologies (2010) report, adoption of e-procurement technology in an organization enables a firm to organize its interactions with its most crucial suppliers, a set of built-in monitoring tools to help control costs, assure maximum supplier performance and keeping an open line of communication with potential suppliers during a business process. The system allows managers to confirm pricing and leverage previous agreements to assure each new price quote is more competitive than the last. E-Procurement helps with the decision-making process by keeping relevant information neatly organized and time-stamped. Most are template-driven which makes all transactions standardized and traceable.

### **1.1.1 Procurement**

Procurement refers to a variety of means through which public and private organizations are able to acquire the products and services they require for their operations. Procurement is a function that takes place in the upstream part of the supply chain in order to ensure that the required products or services can be availed to customers. Large amount of money is spent by organizations to acquire various products and services at various stages of production or service provision (Snider and Rendon, 2001).

Procurement is strategic in nature since it links the organization's suppliers to the strategic objectives of the organization. Procurement translates the strategic objectives of an organization into the sourcing needs that can enable the organization achieve the same. Procurement in the public sector has always been neglected and is characterized by

malpractices that lead to loss of public funds. This is the reason why most governments around the globe have incorporated technology in procurement in order to minimize such occurrences (Snider and Rendon, 2001).

### **1.1.2 E-procurement**

Various researchers defined e-procurement differently: Parida and Parida (2005) define e-procurement as a technology solution that facilitates corporate buying using the Internet. Essentially an Internet/Intranet based purchasing application or hosted service that streamlines buying, trading partners, maximizes trade efficiency across the entire supply chain, and provides strategic e-commerce capabilities in Internet time; Process which supports the procurement and sourcing activities via Internet technologies and enables an efficient negotiation between buyers and suppliers (Gimenez and Lourenço 2004); Electronic acquisition of goods and services in a firm (Turban and King 2006); The automation of the procurement processes so that the sourcing, vendor selection, procurement processes, shipment status tracking and payments can be made in an online environment (Bhaskar 2005).

E-Procurement refers to the use of Internet-based (integrated) information and communication technologies (ICTs) to carry out individual or all stages of the procurement process including search, sourcing, negotiation, ordering, receipt, and post-purchase review (Croom& Brandon-Jones, 2004). While there are various forms of e-Procurement that concentrate on one or many stages of the procurement process such as e-Tendering, e-Marketplace, e-Auction/Reverse Auction, and e-Catalogue/Purchasing, e-Procurement can be viewed more broadly as an end-to-end solution that integrates and streamlines many procurement processes throughout the organization. Although the term end-to-end e-Procurement is popular, industry

and academic analysts indicate that this ideal model is rarely achieved (Department of Information Resources, 2001) and e-Procurement implementations generally involve a mixture of different models.

According to a study carried out by Kipyego (2012) on factors affecting implementation of electronic procurement system in the public sector, costs associated with the Implementation of e-procurement were found to have a direct impact on the Organizations. The study further established that training of users and management's support has a positive impact on the Implementation of the e-procurement system; Turnover of the employees' required continuous training for the incoming staff; Formal recognition backed by legislation of the electronic procurement transactions should be encouraged to accelerate the' rate of Implementation of the System within the public sector; Integration of the Organizations system and those of the suppliers; demonstration of the positive impact of the system and installation of linkages between all Governments agencies should be encouraged for faster Implementation of the e-procurement system in the public sector (Kipyego, 2012).

### **1.1.3 Organizational Performance**

Organizational performance comprises the actual output or results of an organization as measured against its intended outputs (or goals and objectives).According to Richard et al. (2009) organizational performance encompasses three specific areas of firm outcomes: Financial performance (profits, return on assets, return on investment.); Product market performance (sales, market share.); and Shareholder return (total shareholder return, economic value added.).Organizational performance is probably the most widely used dependent

variable in organizational research today yet at the same time it remains one of the most vague and loosely defined constructs. The biggest challenge to organizational performance is the external environment. All organizations operate within some external environment. The challenges that may arise from the external environment include political, economic, socio-cultural, environmental and technological (Snider and Rendon, 2001).

The concept of organizational performance refers to the change in which the managers and governing body of an organization put into place and manage a programme which measures the current level of performance of the organization and then generates ideas for modifying organizational behavior and infrastructure which are put into place to achieve higher output. The primary goals of organizational performance are to increase organizational effectiveness and efficiency to improve the ability of the organization to deliver goods and /or services. Another area in organizational performance that sometimes targets continuous improvement is organizational efficacy, which involves the process of setting organizational goals and objectives in a continuous cycle. Organizational performance at the operational or individual employee level usually involves processes such as statistical quality control. At the organizational level, performance usually involves softer forms of measurement such as customer satisfaction surveys which are used to obtain qualitative information about performance from the viewpoint of customers (Kaplan & Norton, 2001).

Sababu (2001) conducted a study on the effect of business policy on organizational performance among consumer cooperatives in Kenya. The study established that formal strategic management systems in Kenya influence organizational performance. It was also established demographic and socioeconomic factors appear to have no direct effects on

organizational performance. Ongore & K' Obonyo (2011) did an empirical review on the effects of selected corporate governance characteristics on firm performance in Kenya. The findings showed a significant positive relationship between managerial discretion and organizational performance.

Researchers have argued that internal integration of various activities in an organization will be able to enhance economic performance. Flynn et al., (2010) define internal integration as the degree to which two departments collaborate in the management of both inter and intra departmental processes to provide maximum value for the firm. E-procurement has the capacity of acting as an integrative technology that enables integration and improvement of processes between departments (Vickery et al., 2003).

Flynn et al., (2010) further assert that internal integration of organizational processes is a recipe for moderated corporate performance though there is no clear elaboration on how this happens. Narasimhan et al., (2003) concur that there exists a positive effect of e-procurement on firm performance even though no empirical evidence has confirmed this position.

#### **1.1.4 Commercial State Corporations in Kenya**

A state corporation (SC) has various meanings. First, it may be a corporate body established by or under an Act of parliament. Second, the president may by order establish a SC as a corporate body to perform the functions specified in the order. Third, it also represents a bank, a financial institution licensed under banking Act, other company incorporated under the

company Act whose shares, or majority of whose shares are owned by the government or by another state corporation (Wamalwa, 2003).

It is observed that various motives are behind the establishment of public enterprises in the Sub-Saharan African countries (SSA). For instance, in Uganda, the Ugandan Development Corporation created in 1963 a subsidiary known as African Business Promotion Ltd., the objective of which was to “establish and promote our own people in the trade and commerce field generally so that Ugandans may play a reasonable part and hold a reasonable share of the country’s commerce” (Kamung’ a, 2000). Similarly, in Kenya, for desire of sufficient indigenous private entrepreneurship after independence, the government had to use parastatals to fill the existing entrepreneurship gap. Thus, public enterprises served as a means to promote the establishment of private African enterprises (Wamalwa, 2003).

The Kenya government forms state corporations to meet both commercial and social goals. They exist for various reasons including: to correct market failure, to exploit social and political objectives, provide education, health, redistribute income or develop marginal areas. At independence in 1963, parastatals were retooled by Sessional Paper no. 10 of 1965 into vehicles for the indigenization of the economy. Thus majority of key parastatals that exist today were established in the 1960s and 1970s. By 1995 there were 240 parastatals. The number currently stands at 127 (Njiru, 2008).



## **1.2 Statement of the Problem**

Procurement is one department that can contribute tremendously to the organization's efficiency and effectiveness. If the procurement department bought all that is required in the organization at the right time, price, place, quantity and quality all other departments within the organization would derive great benefits from this and would thus be able to serve their customers (both internal and external) better (Snider and Rendon, 2001). If the procurement department is inefficient in its acquisition of goods and services or even works, other departments would be affected and sometimes the consequences can be grave. Since e-procurement is a way of using the internet to make it easier, faster and less expensive to purchase the goods and services they require, the key question is, can e-procurement be used to enhance organizational performance?

E-procurement simplifies the sourcing and purchasing process in an organization. However there is still some resistance to change and therefore the importance of identifying whether e-procurement creates value to a procurement process, how and what are the benefits of changing from traditional procurement process to electronic procurement.

Studies have been done on e-procurement. Batenburg (2007) conducted a study on e-procurement adoption by European firms. The study concluded that there exists country differences in e-procurement adoption, and that firms from countries with a low uncertainty avoidance such as Germany and the UK are the early adopters of e-procurement, while countries that are less reluctant to change such as Spain and France have lower adoption rates. Another study was also carried out by Greunen, et al. (2010) on the implementation of regulation-based e-procurement in the Eastern Cape provincial administration, South Africa.

The study found that measurable benefits of supply chain management have not yet been realized due to general limited understanding of how supply chain management concept works within government environment.

There are local studies that have been carried out in e-procurement. These include: Orori (2011) on factors that influence the introduction of e-procurement in retail industry: a survey of retail chain supermarkets in Kenya; Njoroge (2010) on factors influencing e-procurement practices in construction industry in Kenya and Mburu (2011) on the role of e-procurement in enhancing efficiency in telecommunication industry (A Case Study of Safaricom Limited Company-Kenya).

It is however clear that the studies have not focused on the impact of e-procurement on the performance of state corporations. To address this gap, this study focused on the impact of e-procurement on the performance with a specific reference to commercial state corporations in Kenya. The study sought answers to the following questions: To what extent have commercial state corporations adopted e-procurement and what are the effects of e-procurement on the performance of commercial state corporations in Kenya?

### **1.3 Research Objectives**

#### **1.3.1 General Objective**

To establish the effects of e-procurement on the performance of commercial state corporations in Kenya.

### **1.3.2 Specific Objectives**

- i. To establish the extent to which state corporations have adopted e-procurement
- ii. To find the effects of e-procurement on the performance of commercial state corporations in Kenya

### **1.4 Value of the Study**

The findings of the study will be relevant to commercial state corporations in Kenya's strategic plan and operational plans in that it will give the Corporations the milestones in strategic measurements towards integrating e-procurement as a strategy for growth and performance.

The findings of the study will also enable employees of commercial state corporations in Kenya to appreciate their role towards business development, growth and strategic adoption module for the success of the corporations. Staff will also be motivated towards improving the services they offer and understand customer's perception in service delivery in efforts to achieve the world class organizational status.

Researchers will also benefit from the findings of this study since it will provide additional knowledge to the already existing literature on e-procurement. The findings and gaps of this study may act as ground for further research.

The findings of the study may also serve as a benchmark to other organizations who intend to adopt e-procurement. It will enable them to better understand the role and effects of e-procurement in the performance of an organization.

## **CHAPTER TWO: LITERATURE REVIEW**

### **2.0 Introduction**

This chapter presents a review of the studies that have been conducted in e-procurement and organizational performance. The chapter covers e-procurement, theoretical review (which discusses the theories that have contributed and have relevance to the development of business procurement function, empirical review (which examines the practical evidence from various studies) and conceptual framework.

### **2.1 The Role of e-procurement**

Driven by the increasing trend toward purchasing inputs and other raw materials from outside the organization, implementing electronic procurement (e-procurement) has become a significant tactic in most companies' e-business strategies (Deloitte Consulting, 2001). Today baseline procurement capabilities are rapidly becoming a cost of doing business. More and more companies are conscious of the needs to introduce Internet-based technologies in their order process, due to the benefits of saving transaction cost, increasing competitive sourcing opportunities, and enhancing inter-organizational coordination.

Internal customer satisfaction, through E-Procurement function can usually contribute to the competitive position of any company in many other ways than first through cost serving Van Weele (2005) presents a few of these was such as: reduction of quality cost – e-procurement can reduce quality costs by making sure that selected suppliers deliver a product of service that does not exceed extensive quality control. E-Procurement can also reduce quality costs by making sure that the components bought do not load to complaints on the user department

or final product to the customer. Product standardization internal customer satisfaction can be enhanced through E-procurement due to the product variety concept. This can be achieved by reducing the number of different components and or the number of suppliers via set product standards. Contribution to product design and innovation of then innovation in industry come from suppliers or are results from intensive interactions between suppliers and user department in any organization. By actively encouraging this kind of interactions E-Procurement can contribute to fast and to continued innovation and improvement of product and user satisfaction.

Stock reduction, through electronic transaction the sped and real time transaction processes, reduces the amount of stock laying idle in stores and thereby gainful capital employment in other key business proposes or areas. Increasing flexibility E-Procurement necessitates fallibility two edge business flexibility. Service provider companies endeavor to meet their suppliers to be flexible too (Chen, Paulraj and Lado, 2004). Hence if a company wishes to offer flexibility to its customers it might also have to demand it from its suppliers. The EDI and synchronized data system can make it cashier to inform suppliers about charge in demand overtime fostering purchasing synergy. Many companies have a business unit structure where the business units are autonomous. In such a structure the business unit managers are responsible both revenue and cost, hence purchasing is usually done locally through E-Procurement, purchasing officers at the different units can make significant savings by coordination their purchasing with other units (Chen, Paulraj and Lado, 2004).

E-Procurement system is a compound application that contains many usable functions to assist company in processing the activities of purchasing transaction. The use of a Web-based

procurement system can strengthen search ability, facilitate faster and more accurate data transmission, provide quicker and more plentiful information, and achieve relatively low communications and coordination cost. Hence, Web-based procurement mainly affects four of the organization's major B2B tasks: search, purchase processing, monitoring and control, and coordination (Subramaniam and Shaw 2002).

E-procurement has covered procurement automation for internal organizational processes, and supplier collaboration for inter-organizational processes. The former addresses automated, paperless internal process from end user item selection, to creation and routing of purchase request and approval to purchase order creation, and receiving. The latter is about connectivity with suppliers for electronic catalogs, transaction management and on-going relationship management. To realize the benefits of Web-based e-procurement, an understanding of the impacts influencing the value forming is needed so that the solution may be developed to facilitate the implementation of Web-based e-procurement system (Subramaniam and Shaw 2002).

There are several theories, which have contributed and have relevance to the development of business procurement function in relation to effective management and financial performance. In an organization purchasing management concept (PMC) could be analyzed using several theories, which help in understanding how an organization's E-Procurement system and procedures enhances internal customer levels at different levels. The thinking of strategic procurement policies has been influenced by several theories some of which are discussed below.

Chen, Paulraj and Lado (2004) in their optics states that strategic purchasing is a vital link in a working supply chain. They mean that strategic purchasing can give e a firm a competitive advantage by enabling the firms to:Foster close working relationships with a limited number of suppliers; Promote open communication among suppliers chain partners and Develop long-term strategic relationship orientation to achieve mutual gains. Chen et al (2004) states that strategic purchasing will lead to communications with suppliers, a limited number of suppliers and a way term orientation. Chen at al (2004) prove all of those connections significant. The conclusion to be drawn from this theory is that strategic purchasing arrangement can be an important link in the supply chain and contributes towards enhancing internal user department satisfactory and the overall financial results of a company.

Axels son and league – Hellmann (1991) state that a suitable way to govern purchasing is through target settling and measuring their theory, this could be done through key performance indicates. The theory divides the KPTs: Into some categories price related, Quality related, Delivery related, Inventory related savings related, Activity related and other.

Van Woole (2005) presents two areas in which purchasing performance can be measured, purchasing effectiveness and purchasing efficiency. The theory states that purchasing effectiveness is a measure of what has been accomplished and purchasing efficiency is a measure of what resources has been used to accomplish it. Based on Van Wools (2005) four dimensions, Cost/price, product/ quality, logistics & organization. Enhancing internal customer satisfaction through the E-procurement can be capitalized via this theory.

## **2.2 E-procurement and organizational performance**

E-procurement system plays a fundamental role in B2B purchasing by streamlining the buying process and providing the information needed to make more effective purchasing decisions (Osmonbekov et al. 2002). Previous studies allude to the fact that many companies have found benefits from their implementation of e-procurement system. The adoption of Web-based e-procurement system in the B2B purchasing transaction allows firms to reduce transaction costs, improve internal procurement process efficiency, and increase collaboration with suppliers (Barbieri and Zanoni 2005). The benefits of technology-based supports for procurement activities can be organized into two broad categories: organizational level and inter-organizational level. In organizational level, previous studies suggested that implementing e-procurement system could make company's procurement process more efficient and effective through automating procurement process, reengineering the internal processes and enhancing inter-organizational coordination.

For example, Davila et al. (2003) thought that implementing e-procurement the firm could shorten the order fulfillment cycle time, lower inventory levels and the price paid for goods, and reduce administrative costs of procurement. Eakin (2003) argued that the benefits of e-procurement can be classified to hard benefits (such as price savings and process cost reductions), soft benefits (such as individual time freed up through more efficient processes), and intangible benefits (such as cultural change, financial approval for all spending, and high visibility of supplier performance). Presutti (2003) found e-procurement system can bring benefits to the company such as reducing time to- market cycles, reducing material and transactions costs, and reducing stock levels. Chaffey (2004) argued that the benefits of e-



procurement include reduced purchasing cycle time and cost, enhanced budgetary control, elimination of administrative errors, increasing buyers' productivity, lowering prices through product standardization and consolidation of buys, improving the payment process, and improving information management.

Implementing Web-based e-procurement system not only could make the operational processes of the buyer organization more effective but also could make the order fulfillment process of the supplier organization more efficient and improve partner relationship management. The main objective of the order fulfillment process that buyer expected is supplier can deliver qualified products to fulfill its orders at the right time and right place (Lin and Shaw 1998). The order fulfillment performance can be improved if supplier can recognize the order, so that the order demand patterns are more transparent to the supplier. In order for supplier to enhance order fulfillment performance, buyer and supplier have to share information. For instance, Toyota shares its inventory and sales information with its suppliers. Having access to such information helps Toyota's suppliers plan and manage their operations better and Toyota can coordinate the inventory orders effectively; as a result, the implementation of just in time (JIT) delivery strategy can be achieved (Chopra and Meindl 2001). Web-based e-procurement enables the information to be shared among trading partners, such as sales forecasts, production schedules, inventory levels, and product specifications.

Developing a purchasing strategy that will enhance internal customer satisfaction on e-Procurement function is a complex process and there are a lot of factors that has to be taken

into account, which factors vary between companies, commodities, situation and environment. Dobler and Burt (1996) states that if suppliers are involved earlier in the buyer design process of the E-procurement system, they can contribute with their expertise in the following areas: Material specifications, tolerances, standardization, order sizes, process ethanol's in supplier manufacturing, packaging, inventory & transportation, via a web designed interlink. Further Dobler and Burt (1996) states that another aspect to consider when developing a strategy is how many parallel sources supply should be used.

A company can chose to take all supply from a single supplier, which is usually called single sourcing, or they can take their supplies form two or more suppliers, called dual or multiple sourcing. The different strategic are appropriate in different situations. According to Dobler and Burt (1996) single sourcing is appropriate when. Bottler prices can be achieved through larger volumes (economies of scale), quality is important, A strong influence over a supplier is advantageous, In addition to quality, control and coordination required with just-in-time manufacturing require a single source, significantly lower freight costs many result; special tooling or machinery is required, and the use of more than one supplier is impractical or excessively costly, total system inventory will be reduces, an improved commitment on the supplier's part results, improved interdependency and risk sharing result and time to market is critical.

On the other hand Dobler and Burt (1996) states that dual or multiple sourcing many is appropriate. To protect the buyer of shortage, strikes or other emergencies, to maintain competition and provide a back-up source; to meet local content requirements for international manufacturing locations; more also to meet customer's volume requirements,

avoid lethargy or complacency on the part of the single source supplier when the customer is a small player in the market for a specific item, when technology part is uncertain and in areas where suppliers tend to leapfrog each other technologically.

Cronin- Harris (2004) state a company has two main windows to the outside world, the sales department and the purchasing department. Because of this they mean that the actions of these two departments are extremely visible and therefore important for the perception of the firm externally. According to Cronin. Harris (2004), studies have shown that behavior of the purchasing department in ethical issue has a major effect on the behavior of the rest of the company in similar situation (Internal customers). It is therefore essential to ensure ethical behavior from the purchasing department. The author states that the best way to ensure this is through the development and enforcement of a relevant ethics policy and through continuous training and education.

According to Heinritz et al (1991), a purchaser is an agent for his/her company who has been given the authority by owner or management to commit funds. There are often monetary limit to the amount that may be spent by any single buyer without securing approval of the expenditure by general management. The author's state further that authority should be comparable with responsibility and the ability to meet that responsibility. Hein Ritz et al (1991), states that managers gives purchasers authority, they usually control cost by restricting the amounts that a purchaser has the authority to sign for. There might be several steps of authority, for instance a single buyer ties the authority to sign deals up to a certain amount, over that amount the deal has to be signed by a senior purchaser up to a certain amount and over that by the chief procurement officer and above that by the CEO.

### **2.3 Summary and research gaps**

E-procurement constitutes a very important information technology managerial tool that has the potential of improving and integrating various functions across the organization. This internal integration can enhance the current performance of an organization as well as improve the future performance of the organization. E-procurement can also help drive future confidence in the face of both internal and external risk. E-Procurement can reduce quality costs by making sure that selected suppliers deliver a product of service that does not exceed extensive quality control. E-Procurement can also reduce quality costs by making sure that the components bought do not lead to complaints on the user department or final product to the customer.

The literatures reviewed have indicated that there are no studies that have been carried out on the effects of e-procurement on the performance of organizations in the public sector in Kenya. Studies on e-procurement are also few since the concept has not been adopted in most organizations. There is need therefore to conduct a study to establish the effects of e-procurement on the performance of Postal Corporation of Kenya.

### **2.4 Conceptual Framework and Research Gaps**

The conceptual framework below illustrates the relationship between the independent variables on one hand and the dependent variable on the other. E-procurement has the potential of bringing the following benefits: reduces operational cost, streamlines internal process, guarantees real-time response to market and provides real-time response to the customer. These benefits are likely to affect organizational performance. There are other

factors however that may intervene and determine the level of performance. These intervening variables include: financial resources, employee perception, and organizational culture.

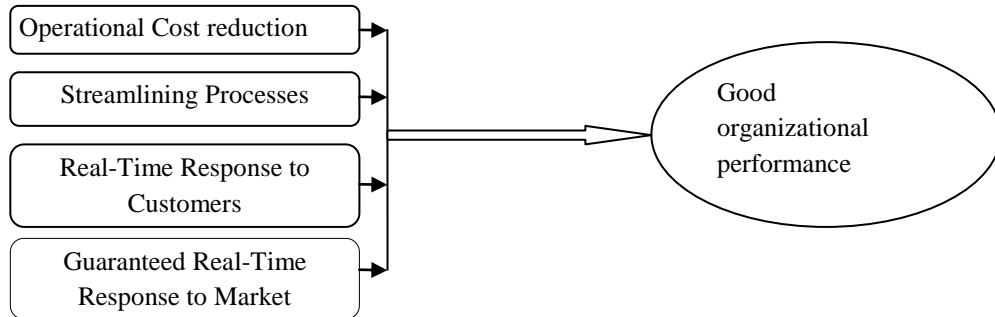

## **CHAPTER THREE: RESEARCH METHODOLOGY**

### **3.1 Introduction**

The purpose of the study was to analyse the impact of E-procurement organization performance. This chapter focused on the research methodology to be applied in respect of the research design, target population, sampling design, sampling methods and techniques, data collection methods, techniques and procedures.

### **3.2 Research Design**

The study adopted a descriptive research design. Descriptive research design allowed the researcher to study the elements in their natural form without making any alterations to them. The design also allowed the researcher to come up with descriptive statistics that can assist in explaining the relationship that exists among variables. Rowley (2002) indicates that a case study research is good for contemporary events when the relevant behaviour cannot be manipulated. Typically case study research uses a variety of evidence from different sources, such as documents, interviews and observation, and this goes beyond the range of sources of evidence that might be available in historical study.

### **3.3 The Population**

The study targeted all the commercial state corporations in Kenya. According to the government of Kenya, there are currently 240 commercial state corporations in the country. The 240 formed the population of the study.

### **3.4 The Sample**

The researcher conducted purposive or judgemental sampling among the commercial state corporations. According to Elder (2009) a purposive sample refers to selection of units based on personal judgement rather than randomization. This judgemental sampling is in some way “representative” of the population of interest without sampling at random. One of the commonest uses of purposive sampling is in studies based on very small numbers of areas or sites. It is more applicable in this study since the researcher targets only those commercial state corporations he feels have adopted e-procurement. The researcher picked 10% of the commercial state corporations hence 24 were selected. Two respondents were randomly selected from each one of them to participate in the study.

### **3.5 Data Collection**

The researcher gathered primary data. In collecting data, the researcher relied on the primary data collected from the subjects in the sample through key informant interview and questionnaires. The questionnaire had three sections. The first section contained questions on the bio-data of the respondents; the second question contained questions on the extent to which commercial state corporations have adopted e- procurement; the third section solicited data on the effect of e-procurement on the performance of commercial state corporations in Kenya. The questionnaires were administered by drop and pick method.

### **3.6 Data Analysis and Reporting**

The data collected was sorted and entered into the statistical packages for social sciences for analysis. Frequencies and percentages were used to analyze demographic data, establish extent to which commercial state corporations have adopted e- procurement and the effects of

e-procurement on performance of commercial state corporations was analysed using regression analysis. The findings were presented in tables, pie charts and histograms. In order to establish the effect of e-procurement on performance, regression analysis was employed.

The following regression equation was used:  $P = a + b_1 x_1 + b_2 x_2 + b_3 x_3 + b_4 x_4 + b_5 x_5 + e$

Where P = Performance (Better service delivery);  $x_1$  = Operational Cost reduction;  $x_2$  = Streamlining Processes;  $x_3$  = Real-Time Response to Customers;  $x_4$  = Real-Time Response to Market and  $x_5$  = Improving transparency in the procurement process.



## **CHAPTER FOUR: DATA ANALYSIS, FINDINGS AND INTERPRETATIONS**

### **4.1 Introduction**

This chapter presents the data analysis, findings, and interpretations of the study. The data was collected from commercial state corporations in Kenya, analyzed, and presented in the form of tables, pie charts, and histograms. Out of 48 questionnaires distributed to the respondents, only 33 were successfully filled and collected by the researcher. This gave a response rate of 68.75% which was considered adequate for the study.

### **4.2 Organizational profile**

In this section, the study sought to establish whether commercial state corporations in Kenya had adopted e-procurement, the number of years that have elapsed since the adoption of e-procurement and whether the adoption was successful. The study findings are presented and explained in table 4.1 below.

**Table 4.1: Adoption of e-procurement**

<b>Response</b>	<b>Frequency</b>	<b>Percent</b>
Yes	20	60.6
No	13	39.4
Total	33	100.0

As shown by the study findings presented in the table 4.1 above, 60.6% of commercial state corporations in Kenya have adopted e-procurement while 39.4% of them have not. This means that majority of the commercial state corporations in Kenya do practice e-procurement.

**Figure 4.1: Years that have elapsed since adopting e-procurement**

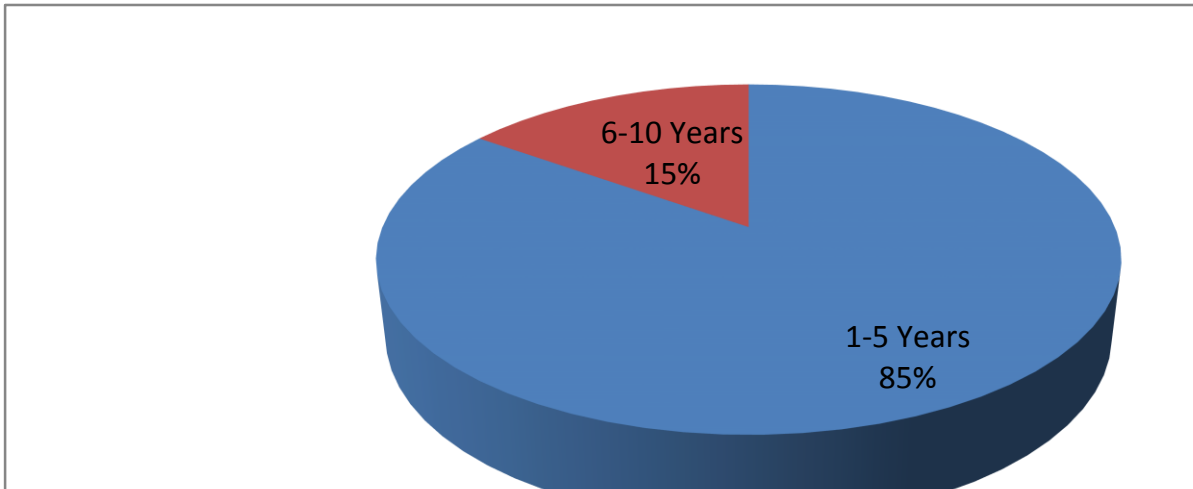

The researcher sought to establish from the respondents the number of years that have elapsed since the adoption of e-procurement among commercial state corporations in Kenya. It is clear from the study findings presented in figure 4.1 above that majority of the respondents representing 85% of the study participants indicated that 1-5 years have elapsed since majority of commercial state corporations adopted e-procurement practices.

**Figure 4.2: Success of the adoption process**

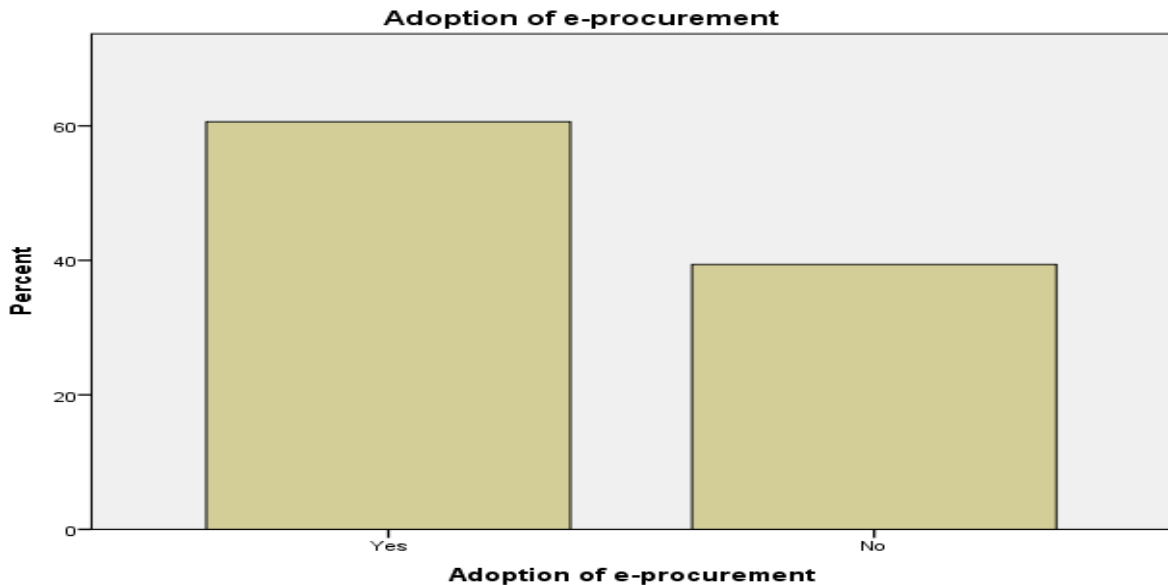

The researcher also wanted to determine from the respondents whether the process of adopting e-procurement among the commercial state corporations in Kenya was successful. From the study findings presented in the figure 4.2, majority of the respondents agreed that the process of adopting e-procurement was successful among commercial state corporations in Kenya.

### 4.3 Adoption of e-procurement

In this section, the researcher sought to determine from the respondents the extent they agreed with various statements concerning the adoption of e-procurement among commercial state corporations in Kenya. The study findings are presented and explained below.

**Table 4.2: Tenders are advertised online**

Response	Frequency	Percent
Strongly agree	13	39.4
Agree	7	21.2
Not sure	8	24.2
Disagree	1	3.0
Strongly disagree	4	12.1
Total	33	100.0

As shown in the table above, majority of the respondents representing 39.4% of the total number of the study participants strongly agreed that commercial state corporations in Kenya advertised tenders online.

**Figure 4.3: Suppliers submit proposals online**

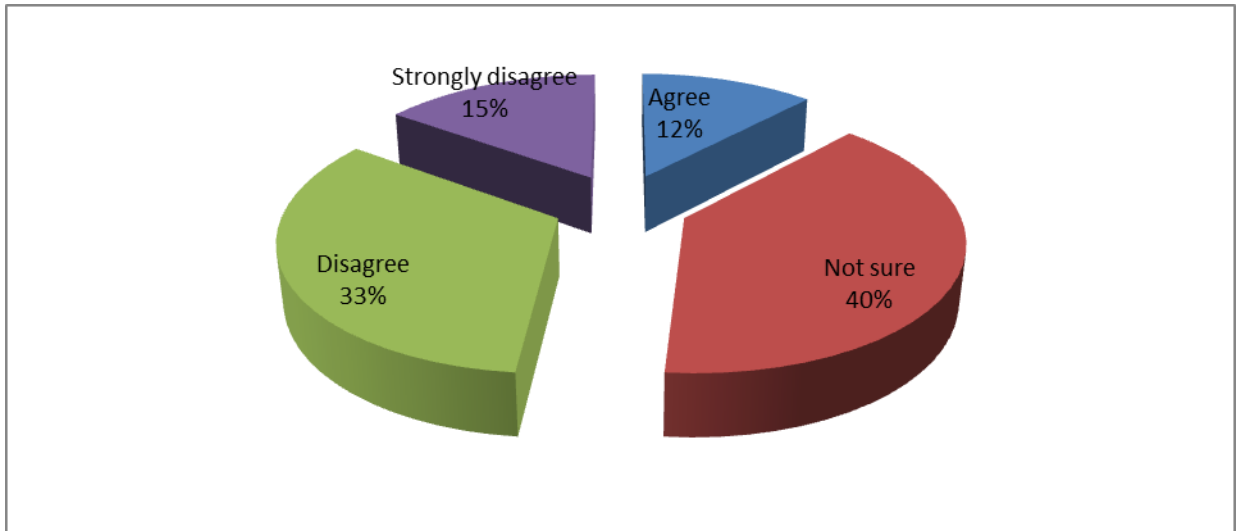

The study also sought to determine the extent to which respondents agreed that prospective suppliers among commercial state corporations in Kenya submitted proposals online. From the study findings presented in figure 4.3 above, majority of the respondents representing 40% of the total number of study participants were not sure whether prospective suppliers among commercial state corporations in Kenya submitted proposals online. The findings also show that a larger proportion of 33% of the respondents disagreed that prospective supplier among commercial state corporations in Kenya submit proposals online.

**Table 4.3: Short listing of tenders is done by the e-procurement system**

Responses	Frequency	Percent
Strongly agree	3	9.1
Agree	4	12.1
Not sure	8	24.2
Disagree	10	30.3
Strongly disagree	8	24.2
Total	33	100.0

As shown in table 4.3 above, the study established that short listing of tenders among state corporations is not done by the e-procurement system. Majority of the respondents representing 30.3% of the total number of the study participants disagreed that short listing of tenders among state corporations is not done by the e-procurement system.

**Figure 4.4: Functioning website to facilitate e-procurement**

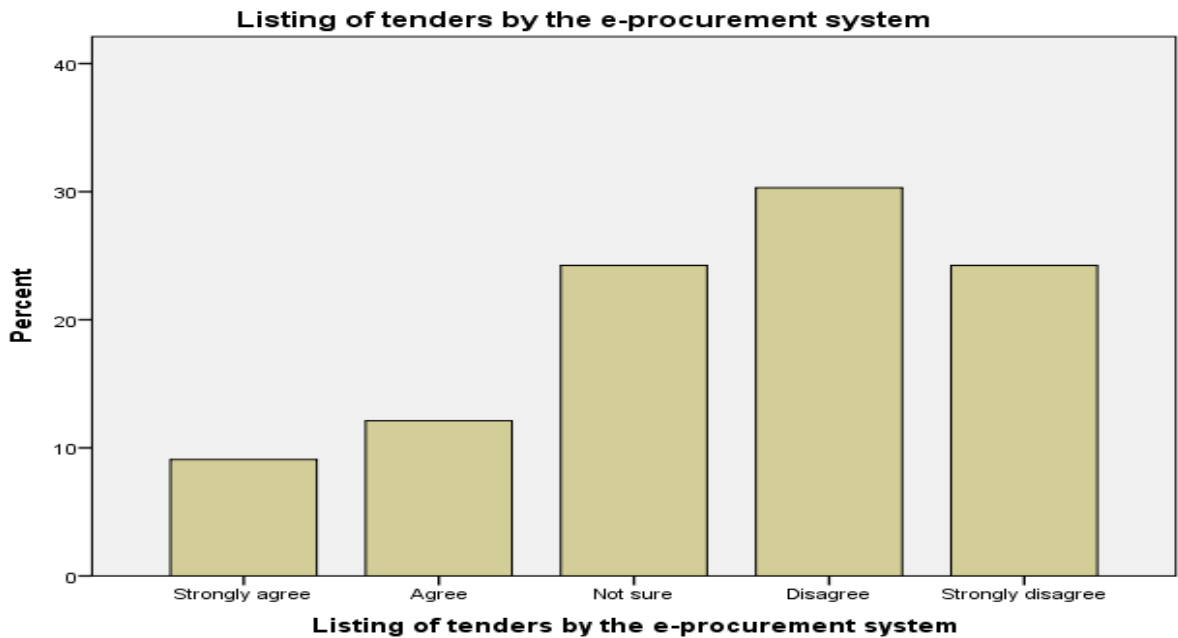

The researcher sought to determine the extent study participants agreed that commercial state corporations in Kenya have functioning websites to facilitate e-procurement. From the study findings as presented in figure 4.4 above, majority of the study participants disagreed that commercial state corporations in Kenya have functioning websites to facilitate e-procurement.

**Table 4.4: Specifications for procured items are posted to company website**

<b>Responses</b>	<b>Frequency</b>	<b>Percent</b>
Strongly agree	4	12.1
Agree	6	18.2
Not sure	10	30.3
Disagree	7	21.2
Strongly disagree	6	18.2
Total	33	100.0

The researcher also sought to establish from the respondents whether commercial state corporations in Kenya post specifications for procured items on their websites. From the study findings presented in table 4.4 above, majority of the study participants were not sure that commercial state corporations in Kenya post specifications for procured items on their websites. They represent 30.3% of the total number of respondents who participated in the study.

**Table 4.5: All company staff makes requisitions online**

<b>Responses</b>	<b>Frequency</b>	<b>Percent</b>
Strongly agree	4	12.1
Agree	3	9.1
Not sure	11	33.3
Disagree	13	39.4
Strongly disagree	2	6.1
Total	33	100.0

The researcher also wanted to determine from the respondents the extent they agreed that all the staff members among commercial state corporations in Kenya make requisitions online. As shown in table 4.5 above, majority of the study participants (39.4%) disagreed that all the staff members among commercial state corporations in Kenya make requisitions online.

**Figure 4.5: Call for proposals is done through the company website**

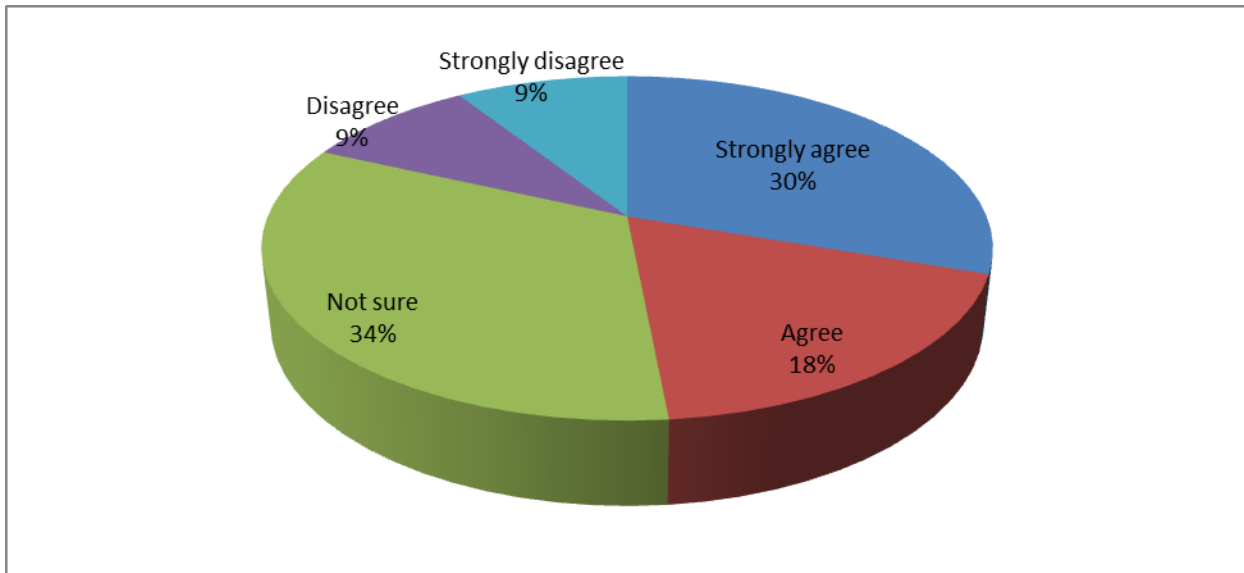

The researcher also sought to ascertain from the respondents the extent they agreed that call for proposals among commercial state corporations in Kenya was done through their respective websites. From the study findings presented in figure 4.5, majority of the respondents (34%) neither agreed nor disagreed that call for proposals among commercial state corporations in Kenya was done through their websites. However, it is also clear that 30% of the study participants strongly agreed that call for proposals among commercial state corporations in Kenya is done through the firms' websites.

#### 4.4 Effects of e-procurement on performance of commercial state corporations in Kenya

In this section, the researcher sought to establish the extent respondents agreed with various statements concerning the effect of e-procurement on performance of commercial state corporations in Kenya. The findings of the study are presented and explained in the following subsections.

**Figure 4.6: Leads to cost reduction**

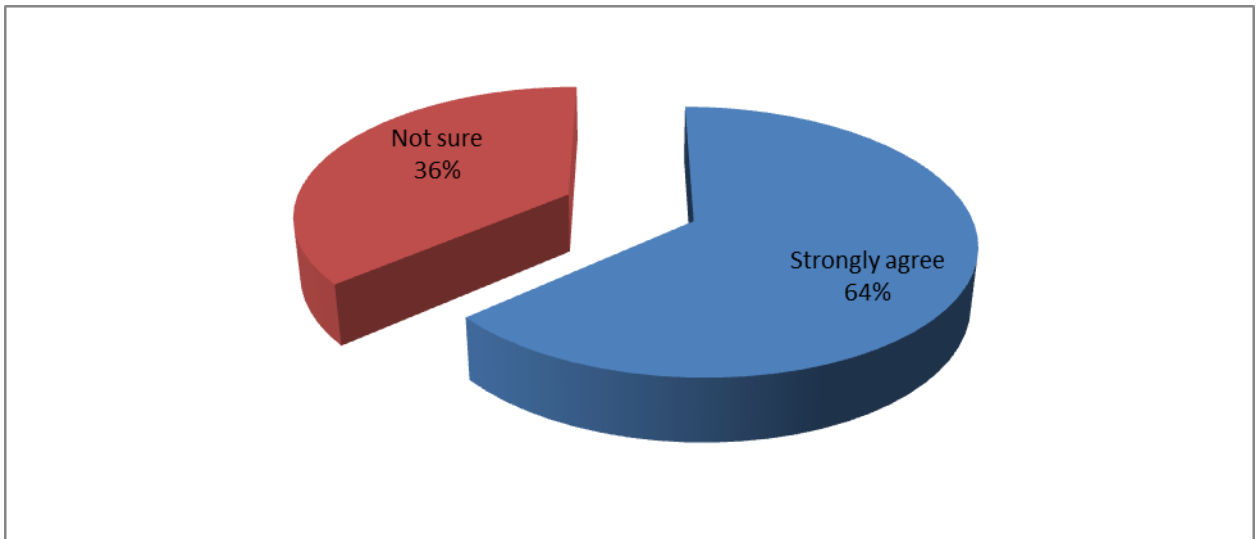

The researcher wanted to determine from the respondents whether e-procurement led to cost reduction among commercial state corporations in Kenya. As shown in figure 4.6 above, 64% of the respondents strongly agreed that e-procurement led to cost reductions among commercial state corporations in Kenya while 36% were not sure.



**Figure 4.7: Leads to better service delivery**

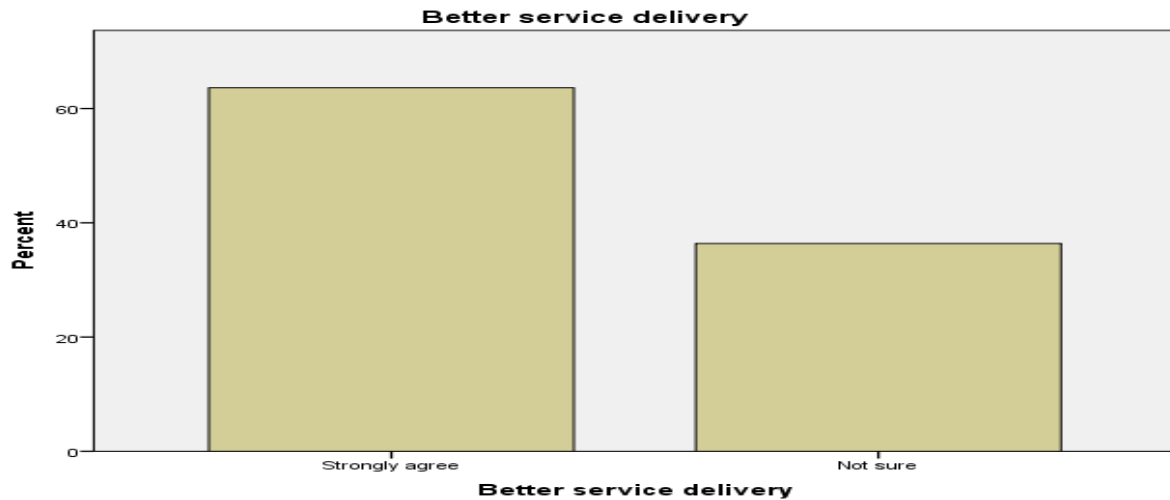

The researcher also wanted to ascertain whether e-procurement led to better service delivery among commercial state corporations in Kenya. Figure 4.7 above shows that e-procurement leads to better service delivery among state corporations in Kenya. This may be attributed to the fact that e-procurement process is efficient and saves time as well as resources.

**Table 4.6: Enables the organization to streamline processes**

Responses	Frequency	Percent
Strongly agree	18	54.5
Agree	3	9.1
Not sure	12	36.4
Total	33	100.0

The study sought to determine from the respondents whether e-procurement enabled commercial state corporations in Kenya to streamline procurement processes. From the study findings presented in the table above, majority of the respondents strongly agreed that e-procurement enabled commercial state corporations in Kenya to streamline procurement

processes. They represent 54.5% of the total number of the respondents who participated in the study.

**Figure 4.8: Facilitates real time response to customers**

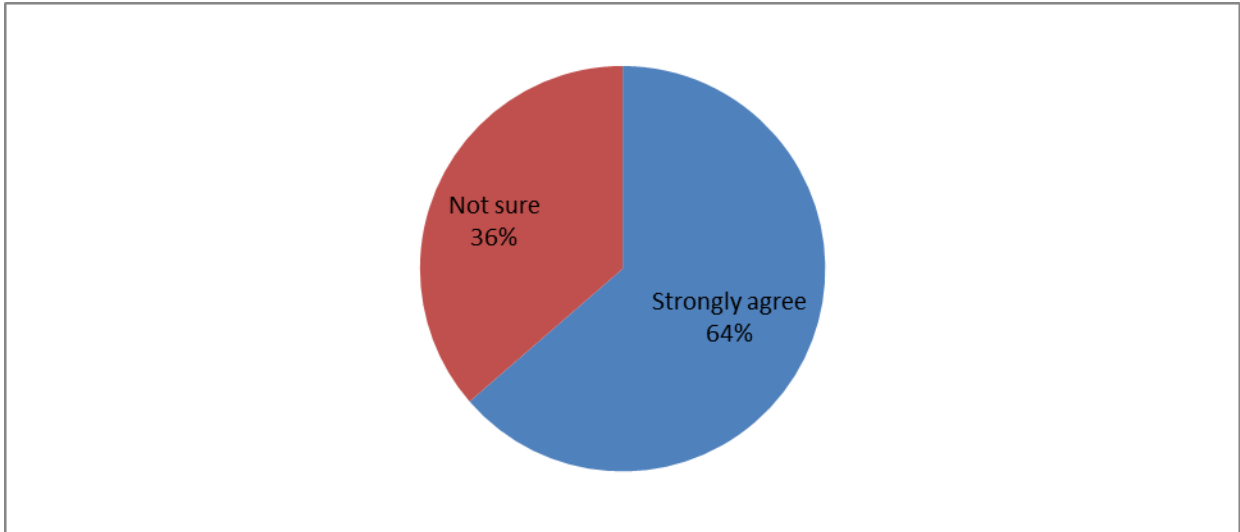

Also, the study sought to establish from the respondents whether e-procurement facilitated real time response to customers among commercial state corporations in Kenya. As shown in 4.8 above, 64% of the study participants strongly agreed that e-procurement facilitated real time response to customers among commercial state corporations in Kenya while 36% were not sure.

**Figure 4.9: Guarantees real time response to the market**

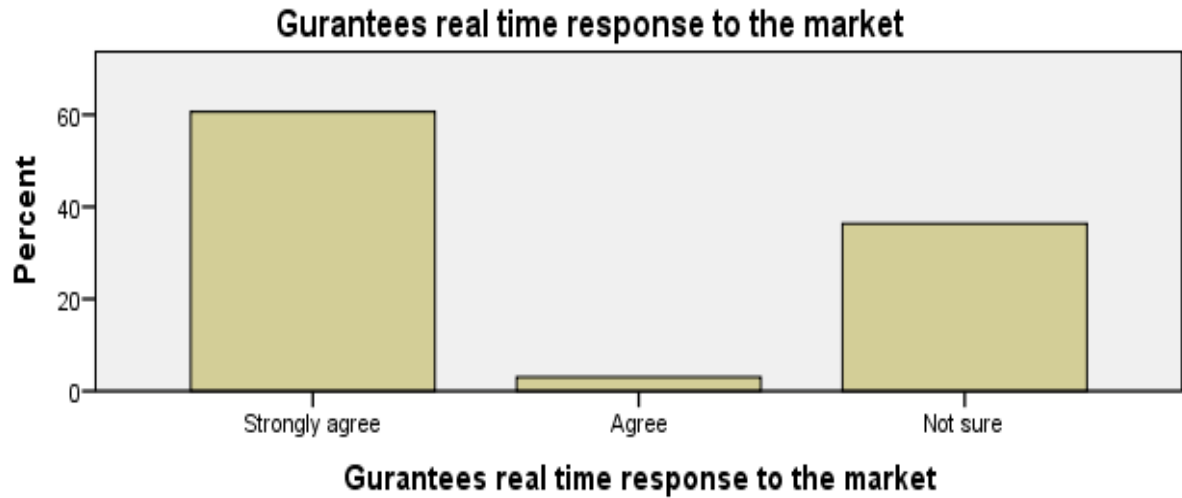

The researcher also sought to establish whether e-procurement guaranteed real time response to the market among commercial state corporations in Kenya. The study findings presented in figure 4.9 indicate that e-procurement guarantees real time response to the market among commercial state corporations in Kenya.

**Table 4.7: Improves transparency in the procurement process**

Responses	Frequency	Percent
Strongly agree	21	63.6
Not sure	12	36.4
Total	33	100.0

The study sought to establish from the respondents whether e-procurement improved transparency in the procurement process among commercial state corporations in Kenya. It is clear from the study findings presented in table 4.7 above that majority of the respondents representing 63.6% of the total number of the study participants strongly agreed that e-

procurement improves transparency in the procurement process among commercial state corporations in Kenya.

**Figure 4.10: Improves the flow of information**

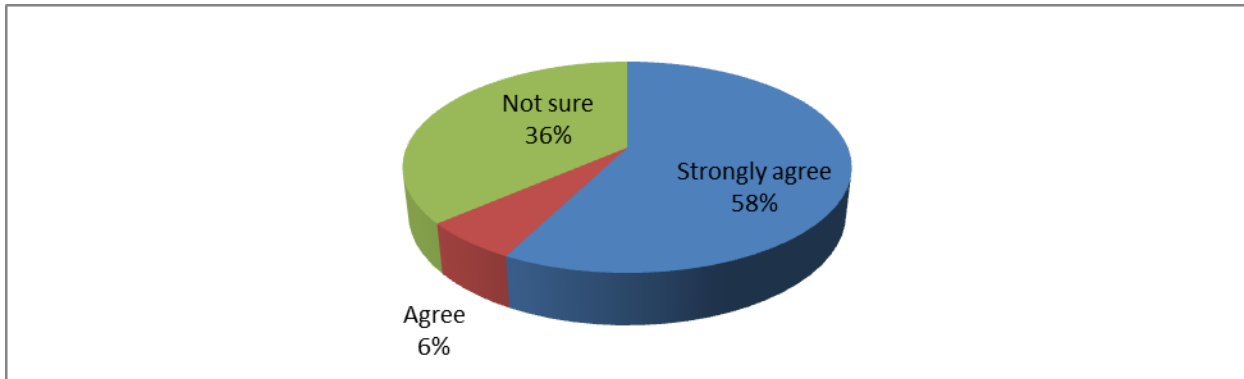

The study also sought to establish from the respondents whether e-procurement improved the flow of information among commercial state corporations in Kenya. It is clear from the study findings presented in figure 4.10 that majority of the respondents representing 58.6% of the study participants strongly agreed that e-procurement improves the flow of information among commercial state corporations in Kenya.

**Table 4.8: Leads to competitive bidding and sourcing**

Responses	Frequency	Percent
Strongly agree	21	63.6
Not sure	12	36.4
Total	33	100.0

The researcher wanted to ascertain from the study participants whether e-procurement led to competitive bidding and sourcing among commercial state corporations in Kenya. From the

study findings presented in table 4.8 above, majority of the study participants strongly agreed that e-procurement leads to competitive bidding and sourcing among commercial state corporations in Kenya. They represent 63.6% of the total respondents who participated in the study.

**Table 4.9: Encourages accountability**

Responses	Frequency	Percent
Strongly agree	21	63.6
Not sure	12	36.4
Total	33	100.0

The researcher also sought to establish from the respondents whether e-procurement led accountability among commercial state corporations in Kenya. From the study findings tabulated above, majority of the respondents strongly agreed that e-procurement led accountability among commercial state corporations in Kenya. They represent 63.6% of the total respondents who participated in the study.

#### 4.5 Regression Analysis

In this section, the study sought to find out the effects of e-procurement on performance of commercial state corporations in Kenya. A regression analysis was conducted to establish the effects of e-procurement on performance of commercial state corporations. Better service delivery was used as a variable for measuring performance among commercial state corporations in Kenya. The researcher adopted the following regression equation:  $P = a + b_1 x_1 + b_2 x_2 + b_3 x_3 + b_4 x_4 + b_5 x_5 + e$  where  $P$  = Performance (Better service delivery);  $x_1$ =Operational cost reduction;  $x_2$ =Streamlining processes;  $x_3$ =Real-time response to

customers  $x_4$  = Real-time response to market and  $x_5$ = Improving transparency in the procurement process.

**Table 4.10: Model Summary<sup>b</sup>**

Model	R	R Square	Adjusted R Square	Std. Error of the Estimate	Change Statistics				
					R Square Change	F Change	df1	df2	Sig. F Change
1	.694 <sup>a</sup>	.487	.393	.328	.431	12.634	2	34	.000

a. Predictors: (Constant), Operational cost reduction, Streamlining processes, Real-time response to customers, Real-time response to market, Improving transparency in the procurement process.

b. Dependent Variable: Performance (Better service delivery)

As shown in table 4.10 above, the Adjusted ( $R^2$ ) known as the coefficient of determination provides a value of 0.393. This value indicates that 39.3% of the performance of state corporations in Kenya is influenced by the effects of e-procurement process i.e. operational cost reduction, streamlining process, real time responses to customers, real time response to market and improving transparency in the procurement process. Whereas the remaining variance of 60.7% of the performance of state corporations in Kenya is influenced by other factors other than e-procurement.

**Table 4.11: Coefficients<sup>a</sup>**

Model	Unstandardized Coefficients		Standardized Coefficients
	B	Std. Error	Beta
(Constant)	1.484	.051	
Operational cost reduction	.972	.027	.060
Streamlining processes	.238	.074	.594
Real-time response to Customers	.213	.158	.217
Real-time response to market	.226	.267	.328
Improving transparency in the procurement process	.257	.045	.175

The regression equation established from the table of coefficients above that can be used to explain the effects of e-procurement on performance of commercial state corporations in Kenya is as follows:  $P = 1.484 + 0.972 x_1 + 0.238 x_2 + 0.213 x_3 + 0.226 x_4 + 0.257 x_5$ . The equation shows that there is a positive relationship between performance and the effects of e-procurement among commercial state corporations in Kenya.

## **CHAPTER FIVE: SUMMARY OF FINDINGS, CONCLUSIONS AND RECOMMENDATIONS**

### **5.1 Introduction**

This chapter presents a summary of the findings from a study on electronic procurement and organizational performance among commercial state corporations in Kenya. The chapter also presents the conclusions drawn from the findings, the recommendations made based on the findings of the study as well as suggestions for further research.

### **5.2 Summary of Findings**

The study established that most of the commercial state corporations in Kenya have successfully implemented e-procurement. It was however clear that most of them implemented e-procurement recently since they have had this system for less than five years. This is a clear indication that e-procurement implementation among commercial state corporations in Kenya is not a very old concept hence it is at its piloting stage.

Despite the fact that most commercial state corporations in Kenya indicated that they have successfully adopted e-procurement, it was clear from the findings that most of the activities associated with e-procurement were still being handled the traditional manual style. For instance the study found out that most of the commercial state corporations in Kenya do not advertise their request for proposals online. It was also discovered that short listing of suppliers is also not done online using the e-procurement system. It was also evident that suppliers do not submit their proposals online through websites.

The research revealed that most commercial state corporations in Kenya have a fully function website even though most of the procurement functions are still handled manually. It was also



evident that the commercial state corporations do not provide the specifications of the items they intend to procure on their websites. This is an indication that even though the commercial state corporations have implemented the e-procurement system, usage of the same is still a challenge that needs to be addressed. Employees need to be trained adequately on the usage of the system since it was established from the study that most of the commercial state corporations' employees do not make online requisitions for items to procure.

The study established that even though most of the procurement functions among commercial state corporations in Kenya are still done in the traditional manual system, some of the corporations have experienced the effects effective and efficient utilization of the e-procurement system. Most of the commercial state corporations indicated that usage of the system has led to drastic cost reduction in their supply chains. It has also enabled them to provide faster and efficient response to customers as well as better service delivery.

The findings also indicate that the e-procurement system has enabled commercial state corporations in Kenya to provide real time response of feedback to both customers and the market. It was also discovered that the e-procurement system has enabled some of the commercial state corporations to streamline their procurement processes. The findings also indicated that the system has assisted the corporations to achieve some good level of transparency in the procurement system.

It was clear from the study that implementation of the e-procurement system has other effects on performance of the commercial state corporations such as better flow of information and improved accountability in all the activities and processes being carried out. The system was also found to improve the flow of information along the supply chains of commercial state

corporations in Kenya. The other important benefit that was associated with the implementation of e-procurement is the improvement in competitive bidding and sourcing. The regression results illustrated that performance of commercial state corporations in Kenya is influenced by very many factors other than those associated with e-procurement. E-procurement accounts for only 39.3% of the performance in commercial state corporations in Kenya. The remaining 60.7% is represents the effects caused by other factors other than e-procurement.

### **5.3 Conclusions**

Most of the commercial state corporations in Kenya have adopted the e-procurement system even though several procurement functions are still carried out in the traditional manual system. Some of the functions that are yet to be done through the e-procurement system include: online tendering, online submission of proposals and advertisement or required items online.

E-procurement is associated with a number of effects on the performance of commercial state corporations in Kenya. Among these effects include: real-time response to both the customers and the market; improves transparency and accountability; improves information flow in the supply chain; assists the commercial state corporations in reducing costs and improvement in competitive bidding and sourcing.

### **5.4 Recommendations**

The study has revealed that despite the fact that most commercial state corporations have adopted the e-procurement system, some procurement activities are still handled manually.

There is need for commercial state corporations in Kenya to emphasize on the need to carry out all the procurement functions through e-procurement.

Employees need to be trained on usage of the e-procurement system. This will enable them to operationalize the system. There is also need for commercial state corporations to integrate the various functions so that e-procurement can thrive.

The websites of state corporations need to be regularly updated with the latest information concerning procurement activities. Suppliers should be encouraged to submit their quotations online.

### **5.5 Limitations of the study**

Inadequate time and finances were the major limitations in this study. There was no enough time as well as funding to exhaust all the aspects of electronic procurement and organizational performance among commercial state corporations.

Some of the respondents were not very cooperative due to the high degree of confidentiality required among the state corporations and therefore they were not willing to give information without the authority of the CEO since they feared that the same may leak out to unauthorized persons.

## **5.6 Suggestions for Further Research**

A study should be carried out to establish the reasons behind low utilization of e-procurement among commercial state corporations in Kenya even after the system has been fully installed.

There is need to conduct a comparative study of the effects of e-procurement on performance of the private sector companies and those in the public sector. This will assist in coming up with similarities and differences that can serve as benchmarks.

## REFERENCES

- Barbieri, P. and Zanoni, A. (2005). The e-procurement experience in Italian universities. *Journal of Public Procurement*, 5 (3), 323–343.
- Bhaskar, R., (2005) Procurement strategy: key to successful e-procurement, Available on-line: <http://blogs.ittoolbox.com/supplychain/eprocurement/procurementstrategy-key-to-successful-eprocurement-5125>
- Chaffey, D. (2004). *E-business and e-commerce management: strategy, implementation and practice*. 2nd edition. Financial Times Prentice Hall.
- Chopra, S. and Meindl, P. (2001), *Supply Chain Management: Strategy, Planning, and Operation*. Prentice-Hall, New Jersey.
- Croom, S. & Brandon-Jones, A. (2004). "E-Procurement: Key issues in e-Procurement implementation and operation in the public sector", 13<sup>th</sup> International Purchasing & Supply Education & Research Association (IPSERA) Conference, April 4-7, Catania, Italy.*
- Dai, Q. & Kauffman, R.J. (2001). "Business Models for Internet-Based E Procurement Systems and B2B Electronic Markets: An Exploratory Assessment." A paper presented at the Thirty-Fourth Annual Hawaii International Conference on Systems Sciences, January 3-6, Maui, HI.
- Deloitte Consulting. (2001). *Realizing the B2B procurement Vision: Trends, Challenges and Best Practices in e-Sourcing and procurement*. Deloitte Consulting, New York.
- DOIR- Department of Information Resources (2001). *Assessment of the General Services Commission's Electronic Procurement Project*. Austin, TX.
- Eakin, D. (2003). Measuring e-procurement benefits. *Summit : Canada's magazine on public sector purchasing*. Available at: [http://www.summitconnects.com/Articles\\_Columns/PDF\\_Documents/060104.pdf](http://www.summitconnects.com/Articles_Columns/PDF_Documents/060104.pdf)

e-Business Watch (2006). European e-Business Reports. Available at: < [http://www.ebusiness-watch.org/key\\_reports/synthesis\\_reports.htm](http://www.ebusiness-watch.org/key_reports/synthesis_reports.htm) >

*EPIQ*, (2010).E-Procurement.*Epiq Technologies, Inc.*

Flynn, B., Huo, B. and Xhao, X. (2010) The Impact of Supply Chain Integration on Performance: A Contingency and Configuration Approach. *Journal of Operations Management* 28 (1) pp 58-71.

Giménez, C., Lourenço, H.R., (2004) E-Supply Chain Management: Review, implications and directions for future research, Institut D' estudis Territorials, Working Paper no: 17.

Greunen, D. V., Herselman, M. E. and Niekerk, J. V. (2010) Implementation of regulation-based e-procurement in the Eastern Cape provincial administration. *African Journal of Business Management* Vol. 4(17), pp.3655-3665

Kipyego, M. I. (2012) Factors affecting implementation of electronic procurement system in the public sector: a case of National Aids Control Council, Masters Thesis, Kenyatta University

Koorn, R., Smith, D. & Mueller, C. (2001) *e-Procurement and Online Marketplaces*. Amsterdam, The Netherlands: Compact.

Lin, F. R. and Shaw, M. (1998). Reengineering the order fulfillment process in supply chain networks. *The Information Journal of Flexible Manufacturing Systems*, 10, 197-229.

Mburu, D. K. (2011) The Role of E-Procurement in Enhancing Efficiency in Telecommunication Industry (A Case Study of Safaricom Limited Company-Kenya). Jomo Kenyatta University of Agriculture and Technology

Narasimhan, R. Talluri, S. and Ross, A. (2003) Evaluating E-procurement Solutions. CAPS Research, [www.capsresearch.org](http://www.capsresearch.org)

- Nelson, R., Moody, E., and Stegner, J. (2001), “The Purchasing Machine: How the Top Ten Companies Use Best Practices to Manage their Supply Chain”, The Free Press, New York.
- Njoroge . K. K. (2010) Factors Influencing E-Procurement Practices in Construction Industry in Kenya. Jomo Kenyatta University of Agriculture and Technology
- OGC (2002) *A Guide to e-Procurement for the Public Sector*. Office of Government Commerce, UK.
- Ongore, V. O. and K’ Obonyo, P. O. (2011) Effects of Selected Corporate Governance Characteristics on Firm Performance: Empirical Evidence from Kenya. *International Journal of Economics and Financial Issues* Vol. 1, No. 3, pp.99-122
- Orori, J. M. (2011) Factors That Influence the Introduction of E-Procurement in Retail Industry: A Survey of Retail Chain Supermarkets in Kenya, Unpublished research, Jomo Kenyatta University of Agriculture and Technology
- Osmonbekov, T., Bello, D.C. and Gilliland, D.I. (2002). Adoption of electronic commerce tools in business procurement: enhanced buying center structure and processes. *Journal of Business and Industrial Marketing*, 17 (2/3), 151–166.
- Parida, U., Parida V., (2005) E-procurement: An Indian and Swedish Perspective, A Masters Thesis, Luleå University of Technology.
- Presutti, W.D. (2003). Supply management and e-procurement: creating value added in the supply chain. *Industrial Marketing Management*, 32 (3), 219–226.
- Richard et al. (2009): Measuring Organizational Performance: Towards Methodological Best Practice. *Journal of Management*.
- S&A (2003) *Evaluation and Review of the e- Procurement Pilot Project, Version 1.2*, Department of Premier & Cabinet Final Report: Australia, February.
- Sababu, B. M. (2001) The Effect of Business Policy on Organizational Performance: The Case of Consumer Cooperatives in Kenya. Egerton University PhD Thesis.

Subramaniam, C. and Shaw, M. (2002). A study of value and impact of B2B e-commerce: the case of web-based procurement. *International Journal of Electronic Commerce*, 6 (4), 19-40.

Vickery et al., (2003) The Effect of an Integrative supply chain strategy on customer service and financial performance: An analysis of direct verses indirect relationships. *Journal of operations management* 21 (5) pp. 523-529

Zheng et al., (2004), Small firms and e-business: cautiousness, contingency and cost-benefits. *Journal of Purchasing & Supply Management*, 10(1), 27-39.

Snider, K. and Rendon, R. (2001) Public Procurement: Public Administration and Public Service Perspectives. *Journal of Public Affairs Education*.

Wamalwa, E., (2003). *Factors Influencing Investment Decisions in Parastatals in Kenya*, Unpublished Thesis, Kenyatta University, Kenya.

Kamung'a J. I., (2000). *The Impact of the Method of Privatization used on Firm's Financial Performance: A Study of Privatized Firms*, Unpublished Thesis, Kenyatta University, Kenya.



## APPENDICES

### Appendix I: Research Questionnaire

#### SECTION A: Organizational profile

1. Has your company adopted e-procurement?

Yes

No

2. How many years have elapsed since your company adopted e-procurement?

1-5 years

6-10 years

Above 10

3. Was the adoption process successful?

Yes

No

#### SECTION B

Kindly indicate the extent to which you agree with the following statements concerning the extent to which your firm has adopted e-procurement.

Use the scale of:

1. Strongly agree
2. Agree
3. Not sure
4. Disagree
5. Strongly disagree

<b>EXTENT OF ADOPTION</b>	<b>1</b>	<b>2</b>	<b>3</b>	<b>4</b>	<b>5</b>
Tenders are advertised online					
Prospective suppliers submit proposals online					
Short listing of tenders is done by the e-procurement system					
There is a functioning website to facilitate e-procurement					
Specifications for procured items are posted to company website					
All company staff make requisitions online					
Call for proposals is done through the company website					

How can you rate your performance after adoption of e-procurement? 1. Better 2. Worse

**Section C: Effect of e-procurement on performance of commercial state corporations in Kenya.**

Kindly indicate the extent to which you agree with the following statements concerning the effect of e-procurement on performance.

1. Strongly agree
2. Agree
3. Not sure
4. Disagree
5. Strongly disagree

<b>Effect</b>	<b>1</b>	<b>2</b>	<b>3</b>	<b>4</b>	<b>5</b>
Leads to cost reduction					
Leads to better service delivery					
Enables the organization to streamline processes					
Facilitates real time response to customers					
Guarantees real time response to the market					
Improves transparency in the procurement process					

It improves the flow of information					
It leads to competitive bidding and sourcing					
It encourages accountability					