



# INTERNATIONAL JOURNAL OF ADVANCE RESEARCH, IDEAS AND INNOVATIONS IN TECHNOLOGY

ISSN: 2454-132X

Impact Factor: 6.078

(Volume 7, Issue 3 - V7I3-1214)

Available online at: <https://www.ijariit.com>

## Embedded system design for the forced circulation system

Suhas D. Gokhale

[sdgokh@gmail.com](mailto:sdgokh@gmail.com)

DKTE's Textile and Engineering  
Institute, Ichalkaranji, Maharashtra

Udayraj Vasudev Miraje

[udayrajmiraje2014@gmail.com](mailto:udayrajmiraje2014@gmail.com)

DKTE's Textile and Engineering  
Institute, Ichalkaranji, Maharashtra

Shubham Sanjay Miraje

[shubhammiraje80@gmail.com](mailto:shubhammiraje80@gmail.com)

DKTE's Textile and Engineering  
Institute, Ichalkaranji, Maharashtra

Pratik Sanjeev Mali

[malipratik424@gmail.com](mailto:malipratik424@gmail.com)

DKTE's Textile and Engineering  
Institute, Ichalkaranji, Maharashtra

Aditya Narayan Shedsale

[adityashedsale797@gmail.com](mailto:adityashedsale797@gmail.com)

DKTE's Textile and Engineering Institute,  
Ichalkaranji, Maharashtra

### ABSTRACT

*In today's world, most of the people are shifting towards renewable energy resources like solar which are globally accepted. The Forced Circulation Solar Water Heater System is not well-known, but is one of the efficient types of water heater systems. In our country, such a system uses old techniques and is also costly. But we had upgraded it using Embedded design which is much better in economical and easy upgrade.*

**Keywords**— Solar, Forced Circulation System, Arduino, Renewable Energy

### 1. INTRODUCTION

Solar water heating systems are widely used in domestic and industrial levels. Based on the type of involved circulation, solar water heating can be classified into two groups: natural circulation and forced circulation. Forced circulation system uses electrical pumps, valves and controllers to circulate water. Forced circulation systems are usually used in commercial or industrial heat processing. It is a closed loop system.

Natural circulation system requires vertical piping. Generally natural circulation system is used in case of sub-critical boiler. When we talk about natural circulation it must include drum in the system. Forced circulation system ensures flow of fluid in any direction. Forced circulation system is used in case of super critical boilers. In forced circulation system drum less, boilers are used.

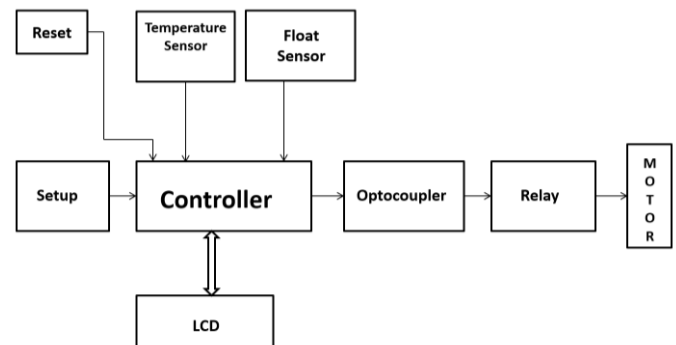

Fig. 1: Block diagram of Forced Circular System

### 2. WORKING

In forced circulation system, water circulates inside the system driven by a pump. When we press the START button the system turns ON. We have used LED in our system which indicates that the system is ON. In our Project we have used the setup button to set the temperature at high level or low level as per our requirement. We have used regulator to set the temperature. We have used two DS18B20 temperature sensors: one is placed at top header and another is placed at bottom header. Now when the temperature of both the sensors goes above the set value then the motor should turn ON. P43 water level measurement sensor is used to measure the level of water in the tank.

During this process if the hot water tank gets full then the motor should STOP and on the LCD it shows "Tank Full". And if some of the water is taken out from the tank, then the motor should

turn ON again as per our previous conditions. If we want to change the temperature during this process is going on, then press the SETUP button and set the temperature. During this process the motor temporarily stops. When the temperature goes below the set value the motor should turn OFF.

### 3. COMPONENTS

**DS18B20 Temperature Sensor:** To measure the rise or fall in temperature, we have used DS18B20 temperature sensor. It is a digital thermometer which provides 9-bit to 12-bit Celsius temperature measurements. It measures temperature in the range of -55°C to +125°C. The communication in this sensor is done through one-wire bus protocol.

**Magnetic Float Sensor P43:** For measurement of water level in the tank we have used magnetic float sensor P43. It is normally a closed switch. Float switch encases a sealed magnet inside it which moves up and down as the temperature level rises or falls. It is used in automatically turn ON/OFF pumps and pool water level control.

### 4. FLOWCHART

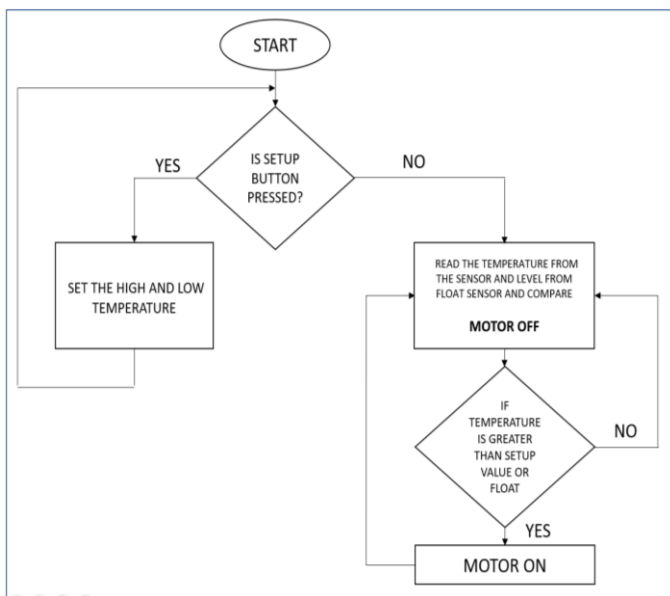

Fig. 2: Flowchart of Forced Circulation System

The above figure represents the working of entire system. The system follows a certain pattern, let's see the condition's:

1. First it will check whether the SET-UP button is pressed or not.
2. If YES then it will ask the user to set up the desired temperature range through the pot connections
3. If NO then:
  - a. It will read the temperature's from both the sensors and the level sensors
  - b. It will check the condition that weather the actual temperature is greater than set up temperature
  - c. If YES the MOTOR will TURN ON else it will go back to read the temperature again.
4. And if any time the level sensor goes HIGH the MOTOR will TURN OFF until the level sensor goes low again.
5. And if any sensor is damaged than the RED LED will glow

### 5. RESULT



Fig. 3: Starting of the System



Fig. 4: Setting the Temperature



Fig. 5: Tank Level Full



Fig. 6: Sensor Damaged Signal

### 6. ENHANCEMENTS IN PRIVEOUS SYSTEM

Back in the days solar systems that were installed that were **NATURAL CIRCULATION SYSTEMS**. In this one of the drawbacks was we have to keep the storage tank above the solar panel. Secondly the orientation of the piping that are used should be vertical, so the water flow is not disturbed. In natural circulation type system, the rate of circulation depends strongly on the density difference between the unheated water and the heated water mixture. As the system not reliable it is not used in industries.

A **FORCED CIRCULATION SYSTEM** uses a pump to circulate water from the panel to the collector tank. In this system the orientation of piping does not matter a lot as pump is used for circulation of water. This way of circulation is more reliable and user friendly so this type of system is widely used over natural commutation. Generally, for this type of system that are built on large scale **PLC based** products are used for the automation. As they are more reliable and have less maintenance they are preferred in industries.

**EMBEDDED SYSTEM DESIGN FOR FORCED CIRCULATION SYSTEM** provide low-cost industrial solutions. As they are way cheaper than a PLC based system. And gives user more options to choose according to preference. And the system can be operated by a less skilled user. One of the advantages is that this system can be mounted on previous system that is already installed

## **7. CONCLUSION**

With tremendous rise in technology, each and every sector is undergoing automation in order to achieve increased

productivity and optimization. The operation of this system is very simple, and less skilled workers can also operate. This system can be used in small or medium scale applications who wish to achieve optimizes results over their old machinery. The installation of this system results in huge amount of cost saving.

## **8. REFERENCES**

- [1] D.J. Close, (1962), 'The performance of solar water heaters with natural circulation', Solar Energy, 6, 33–40.
- [2] C.L. Gupta, H.P. Garg, (1968), 'System design in solar water heaters with natural circulation', Solar Energy, 12, 163–182.
- [3] K.S. Ong, (1976), 'An improved computer programme for the thermal performance of solar water heater', Solar Energy, 183–191.
- [4] R. Uhlemann, N.K. Bansal, (1985), 'A study of pressurized and non-pressurized solar water heating systems with thermosyphonic flow', Solar Energy (In Press).
- [5] B. Norton, S.D. Probert, (1983), 'Measured performance of natural circulation solar energy water heater design', Applied Energy, 16(1), 1–26.