

# Emergent Structures in Supply Chains— A Study Integrating Agent-Based and System Dynamics Modeling

Nadine Schieritz and Andreas Größler  
Industrieseminar, Mannheim University  
D-68131 Mannheim  
nadines@is.bwl.uni-mannheim.de  
agroe@is.bwl.uni-mannheim.de

## Abstract

*Supply chain management is a demanding and complicated task due to its broad scope and the strong connectedness of its objects and issues. In order to make theoretical investigations of supply chains feasible and to support decision-making in real world supply chains, simulation models are used. An integration of system dynamics and discrete agent-based modeling is a promising combination of methods for reducing the a priori complexity of the model. The paper discusses the strengths and weaknesses of system dynamics and discrete agent-based modeling. An approach for integration of the two modeling methodologies is presented. Issues concerning the practical coupling of software environments and a simple, prototypical supply chain model are discussed. Experiments for which the integrated simulation solution is applied are described. Insights in emergent structures in supply chains are derived from these simulation analyses.*

## 1. Introduction

Supply chain management is a demanding and complicated task due to its broad scope and the strong connectedness of its objects and issues [13]. The complexity of supply chains does not allow for pure analytical descriptions of the system's behavior. Even relatively simple supply chain structures lead individuals to systematically make sub-optimal decisions, due to the chain's inherent feedback loops (for example, between orders and incoming goods) and delays (for instance, order processing times). The (negative) effects of feedback loops and delays on decision makers' performance were demonstrated in various studies [7]

[9]; in some of these studies supply chain models were used within an experimental context, in particular the 'beer distribution game' [24] [25].

In order to make theoretical investigations of supply chains feasible and to support decision-making in real world supply chains, simulation models are used. Simulations allow for systematic testing of supply chain strategies. Such experiments can be conducted without being confronted with real world consequences. They make investigations possible and useful, when in the real world situation such experimentation would be too costly or—for ethical reasons—not feasible, or where the decisions and their consequences are too broadly separated in space or in time. Other reasons for the use of simulations are the possibility to replicate the initial situation, and the opportunity to investigate extreme conditions without risk [19]. The use of simulation as a tool for analyzing and evaluating supply chain strategies gained growing attention in recent years [27]. According to Parunak et al. many computer-based models developed in the field of supply chain management use system dynamics [16], an approach for modeling and simulating systems with the help of ordinary differential equations. Recently, the emerging field of complexity science gained interest in the modeling and simulation of supply chains leading to a number of agent-based supply chain models.

In terms of Angerhofer and Angelides, this paper focuses on the presentation of 'research work on improving the modeling approach' of supply chains [5]. The outline of the paper is as follows. In the beginning the strengths and weaknesses of system dynamics and discrete agent-based modeling are discussed. Special emphasis is put on their usability for modeling supply chains and past applications in this field. In the next part, an approach for integration of the two modeling methodologies (system dynamics and agent-based

modeling) is presented. A simple, prototypical implementation of agents in a supply chain and their internal structure is described in the following section. Issues concerning the practical coupling of software environments (Vensim® and eM-Plant®) are discussed. The paper ends with describing experiments for which the integrated simulation solution is applied. Insights in emergent structures in supply chains are derived from these simulation analyses.

## 2. System dynamics and agent-based modeling as modeling paradigms

System dynamics is a continuous simulation methodology that uses concepts from engineering feedback control theory to model and analyze dynamic socioeconomic systems. The mathematical description is realized with the help of ordinary differential equations. “The expressed goal of the system dynamics approach is understanding how a system’s feedback structure gives rise to its dynamic behavior.” [21] The structure consists of multiple interacting feedback loops that depict the policies and continuous processes underlying discrete events [11].

In system dynamics, supply chain modeling and simulation is as old as the discipline itself. In 1958 Jay W. Forrester, the founder of the discipline, modeled a four-level downstream supply chain [10]. Simulating and analyzing this model, Forrester examined “... many current research issues in supply chain management [...] including demand amplification, inventory swings, the effect of advertising policies on production variation, decentralized control, or the impact of the use of information technology on the management process” [5]. The focus on feedback loops and time delays makes system dynamics a valuable tool for the investigation of supply chains. More recently, several studies on supply chain management were conducted using system dynamics modeling [28] [1] [3] [14].

One important advantage of system dynamics is the possibility to deduce the occurrence of a specific behavior mode because the structure that leads to systems’ behavior is made transparent. The drawback of using a traditional system dynamics model of a supply chain is that the structure has to be determined before starting the simulation [21]. For instance, if a flexible structure is to be modeled, every possible participant has to be included into the model and linked to its potential trading partners in advance. Therefore, an integration of system dynamics with discrete agent-based modeling is a promising combination of methods for reducing the a priori complexity of the model.

Agent-based modeling, a simulation methodology coming from the field of complexity science, models systems comprised of multiple idiosyncratic agents: “One of the basic premises of complexity theory is that much of the apparently complex aggregate behavior in any system arises from the relatively simple and localized activities of its agents.” [17] Therefore the basic building block of a system is the individual agent—in the supply chain case, a company. In contrast to system dynamics, agent-based modeling is a bottom-up approach [6]. The dynamics of the system arises from the interactions of agents whereby the behavior of an agent is determined by its cognitive structure, its schema. “Different agents may or may not have different schemata...and schemata may or may not evolve over time. Often agents’ schemata are modeled as a set of rules, but schemata may be characterized in very flexible ways.” [4] Agent-based modeling can be assumed to be a reasonable methodology for the examination of supply chains because in a supply chain a number of individual companies interact with each other using specific internal decision structures [16] [20] [8].

Akkermans uses terminology from the agent-based modeling approach to describe a supply network in a system dynamics simulation environment. [2] The individual agents only differ “in the degree in which they base their relative preferences for customers and suppliers either primarily on their short-term performance towards the agent in question, or mainly upon the intensity of long-term relationships, or on both” [2]. He finds that in general the agents choosing customers and suppliers based on short-term performance achieve better results than their counterparts. Moreover, the relative preferences for a specific customer or supplier become fixed over time, that is, a stable supply network emerges.

Scholl and Phelan compare system dynamics and agent-based modeling.<sup>1</sup> [22] [23] [18] The major differences they have discovered are summarized in Table 1. The table emphasizes the idea of combining the two methodologies in order to derive an approach appropriate for studying supply chains.

	Agent-based modeling	System dynamics modeling
Perspective	bottom-up	top-down
Main building block	individual agent	feedback loop
Unit of analysis	agents' rules	structure of system
Level of modeling	individual	aggregate
Structure of system	not fixed	fixed
Handling of time	discrete or continuous	continuous

**Table 1: Main differences between agent-based and system dynamics modeling**

### 3. An integrative approach for modeling supply chains

The integration of system dynamics with ideas from agent-based modeling offers potential to combine the strengths of the two methodologies. Following an integrative approach, a supply chain can be modeled with two levels of aggregation (Figure 1).

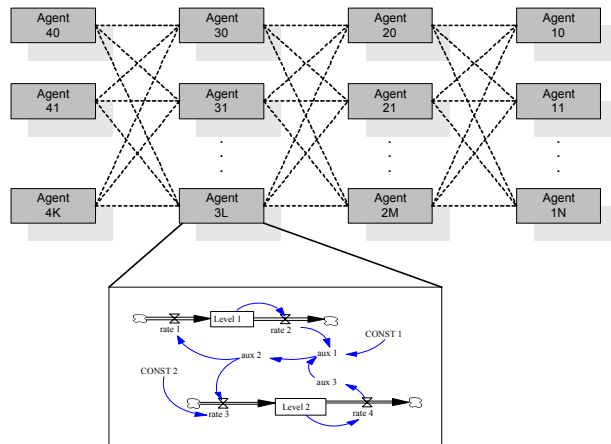

**Figure 1: Macro and micro level of supply chain**

The macro level shows a network of agents that are potential supply chain participants. Every link between two agents can be interpreted as a potential customer-supplier-relationship. Which of the relationships become active is determined during the simulation run, that is, companies of the same tier are exchangeable, they compete against each other. Therefore, at any specific point during a simulation run, the structure of the supply

chain is determined by the interactions between the agents that in turn result from the implementation of the agents' policies as well as the state of the environment. To enable the design of such a flexible structure, a discrete modeling approach, typical for agent-based simulation is used on the macro level.

The supply chain structure is an emergent phenomena resulting from the decisions of the individual agents—which in turn are a result of their policies. These policies represent the internal structure of an agent. In our approach system dynamics is used to model the agents' schemata. This was implicitly suggested by Phelan when he claims that agents' rules are to be modeled by using “feedback and learning algorithms to enable the agent to adapt to its environment over time” [18]. More explicitly Choi et al. state: “Paralleling Senge’s [24] notion of mental models, schema refers to norms, values, beliefs, and assumptions...” [8]. These schemata are implemented on the micro level—the agent level. Agents of the same tier are modeled as individuals, meaning they can have characteristics that are distinct from their competitors. Some of these characteristics are predetermined, for instance, agents have given ordering and order fulfillment policies. Other characteristics evolve over the course of the simulation, for example the volume that is exchanged between two particular agents. The modeling approach used on this level is system dynamics, as it is a well-tried approach for modeling policy making [15] [12] what is seen as a continuous process in contrast to action taking (modeled discretely on the system level).

The simulation proceeds as follows: Starting from an external demand, orders are placed along the supply chain. Every company places orders according to its ordering policy. Before the actual ordering is taking place, a company has to choose a supplier based on its evaluation policy. Different evaluation criteria could be used: the ability to fulfill the order, the number of exchanges that have already taken place between the trading partners, the volume already exchanged, average delivery time of past orders, etc. Here the attractiveness of a supplier is determined by two evaluation criteria: the delivery time and volume. Regarding the shipment of orders two different strategies are implemented: using the FIFO-strategy, an agent ships orders according to the arrival time of the different orders; the relationship-based strategy evaluates the number of exchanges that have been taken place between an agent and its customer. Customers with a higher number of exchanges are preferred and therefore their orders are fulfilled first. Figure 2 shows a possible result of a simulation run. The stronger a link between two agents the more often an exchange has taken place between them.

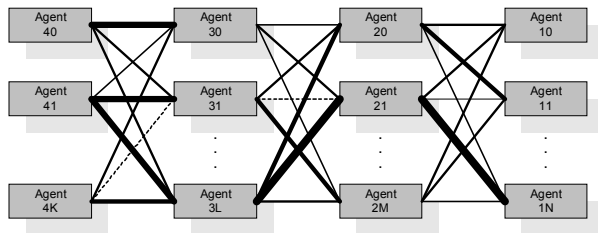

Figure 2: Possible simulation result

#### 4. Agents in a supply chain and their internal structure

As mentioned above, supply agents of one tier can differ from each other. These differences are reflected in the parameterization of their internal system dynamics models and in the type of order fulfillment policies they use. The basic internal structure is identical for every agent, as an agent is derived from a class of generic agents. This structure consists of three modules as depicted in Figure 3.

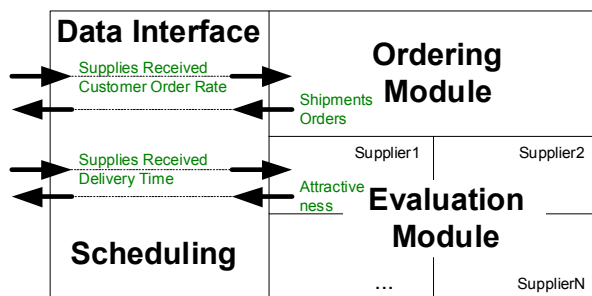

Figure 3: Internal structure of an agent

Two modules—the ordering module and the evaluation module—are system dynamics models, the third regulates the internal scheduling of actions and acts as a data interface within an agent and between agents. The three modules are explained in the following:

The purpose of the ordering module is to describe an agent's ordering policy, for instance how much inventory it holds or in how far it considers the supply line when it places an order. The model is taken from Sterman who models a production process that consists of two sectors: an inventory and a manufacturing sector [26]. As we analyze a downstream supply chain, the manufacturing sector is not taken into account in this paper. Instead, this part of the production process is replaced by the very similar structure of an ordering sector. It enables an agent to consider orders that have been placed but that have not yet been received. In addition the structure of

the inventory sector is adjusted to allow for customer orders that cannot be fulfilled to be backlogged. The model is depicted in Figure 4.

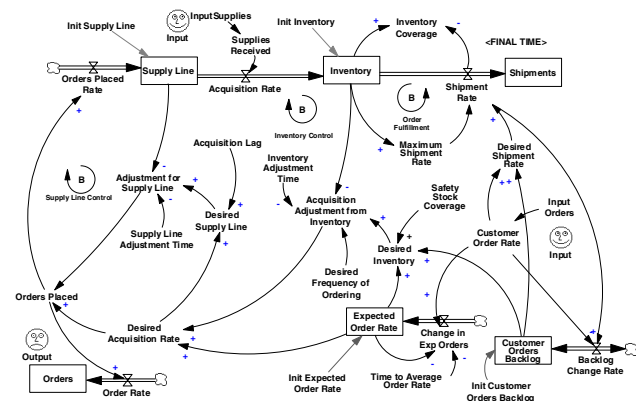

Figure 4: Ordering Module

An agent uses the model to determine how many supplies to order based on the orders and the shipments it receives. The input and output data of the model reflect the interface to the predecessor respective the successor in the supply chain. The material flow input is the supplies that have been received from the predecessors since the last call of the module; the input regarding the information flow is the customer order rate. The output of the ordering module is the orders that are then placed with the supplier chosen. All output data are input data for the ordering models of their recipient.

The evaluation module can be interpreted as an agent's mental model of its suppliers. It consists of a number of evaluation models like the one depicted in Figure 5. An agent holds as many evaluation models as potential suppliers exist.

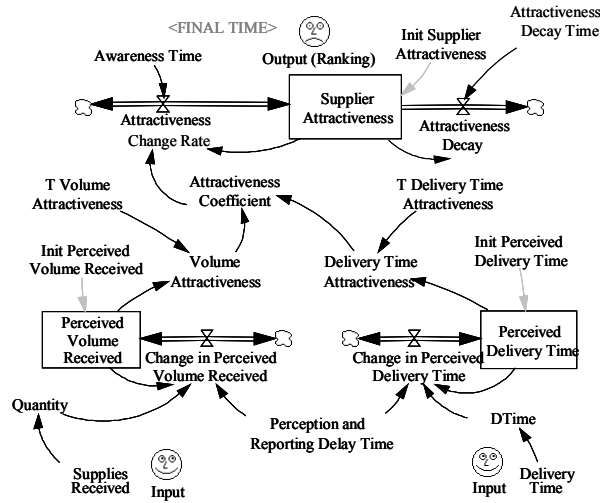

Figure 5: Evaluation Model

The output of the evaluation model—the *supplier attractiveness*—is an agent’s final supplier selection criterion. It is modeled as a level variable that integrates the difference between the inflows and the outflows. The range of values of the variable *supplier attractiveness* lies within  $[-1,1]$ . The *attractiveness decay* reflects the degree to which an agent values the past performance of its suppliers. The inflow respectively outflow *attractiveness change rate* is determined by two sub-criteria: the number of *supplies received* and the *delivery time*. They are the input data of the model. Both parameters have a delayed effect on the actual supplier attractiveness. This delay is modeled with the help of exponential smoothing by the *perception and reporting delay time*. In order to enable comparability between the two different dimensions—time and volume—their smoothed value is transformed into an attractiveness measure with the help of the two functions *T Volume Attractiveness* and *T Delivery Attractiveness*. The higher the number of *supplies received* from one agent, the higher the absolute value of the *attractiveness coefficient* for this particular agent—all other things being equal. The behavior of the *delivery time* is opposite: the higher the *delivery time*, the lower the absolute value of the *attractiveness coefficient*. As soon as the delivery time exceeds a critical value, it becomes negative, what leads to a negative *attractiveness coefficient*. The effect of the *attractiveness coefficient* on the *attractiveness change rate* depends on the current state of the *supplier attractiveness*. An *attractiveness coefficient* greater than the *supplier attractiveness* will lead to a positive *attractiveness change rate* and therefore to an inflow in the level *supplier attractiveness*.

Both, the ordering module and the evaluation module are continuous models; nevertheless their call is event-driven. To evoke an agent’s schemata, specific conditions have to be fulfilled, as described in Figure 6. With such an event-driven call of the continuous models it is avoided that computation time increases exponentially with the number of agents in the supply chain.

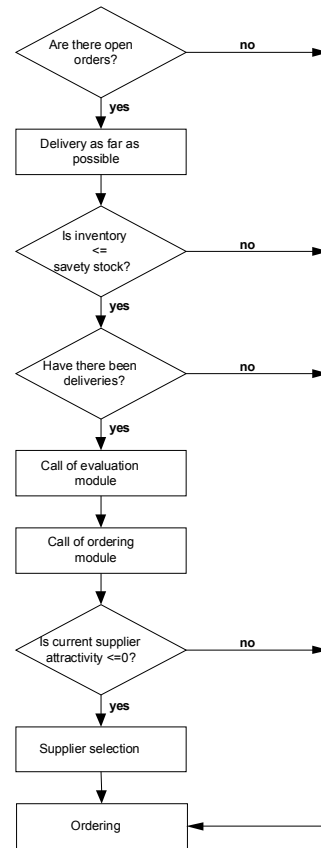

Figure 6: Scheduling within an agent

The third module stores and processes the input and output data of the system dynamics models. The processing includes the supplier selection and the transmission of orders and supplies to suppliers and customers. This module also regulates the communication between the two software environments, Vensim® and eM-Plant®. It takes place via Dynamic Data Exchange (DDE). DDE is a communication system, where a program supporting DDE functions registers with the system under a server name. Now a connection with this program can be established. In our case Vensim® is used as a DDE server, that is eM-Plant® connects to Vensim® and the input and output data and commands are transferred via the established channel.

Finally, the module schedules the sequence of commands. The scheduling is clarified with the help of the following example: an external order is placed. Sequentially every agent of level one is evoked and its internal routine as depicted in Figure 6 is carried out. Now, the level two agents are called and their internal routines are called. This is done for every supply chain level.

## 5. Prototypical implementation of a simple supply chain model

The following section describes a preliminary four-level supply chain model comprising ten agents. Two external sources are added to feed the material respective the information flow: every time step a final customer places a constant order quantity to every agent at level one, a producer delivers goods with a discrete delay time of two periods.

### 5.1. Variation of order fulfillment strategy

A first experiment is conducted to analyze the effects of the two order fulfillment strategies on the structure of the supply chain. In the first scenario, every agent in the supply chain uses the FIFO order fulfillment strategy, whereas in the second scenario every agent uses the relationship-based order fulfillment strategy as described in section 3. The results, as depicted in Figure 7 respective Figure 8 show the aggregated system structure after a simulation time of 50 periods. The stronger a link between two agents the more often an exchange has been taken place between them.

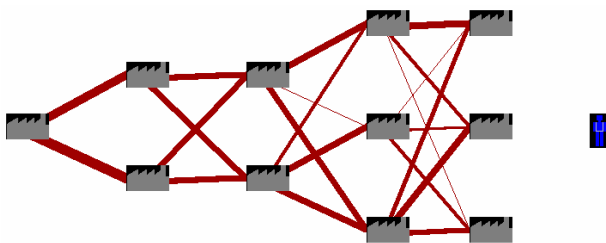

Figure 7: FIFO order fulfillment strategy

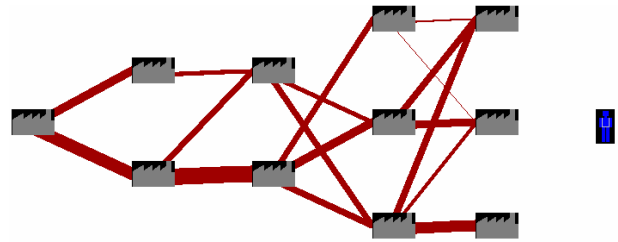

Figure 8: Relationship-based order fulfillment strategy

The relationship-based order fulfillment strategy seems to have a stabilizing effect on the system structure. Using the FIFO strategy, every possible link between two agents is realized in the course of the simulation. On the contrary the relationship-based strategy supports the development of fixed preferences what leads to a long-term relationship between a customer and its supplier and therefore to less supplier switches. To analyze this fact in more detail, Figure 9 shows the preferred supplier over time for one agent on every supply chain level.

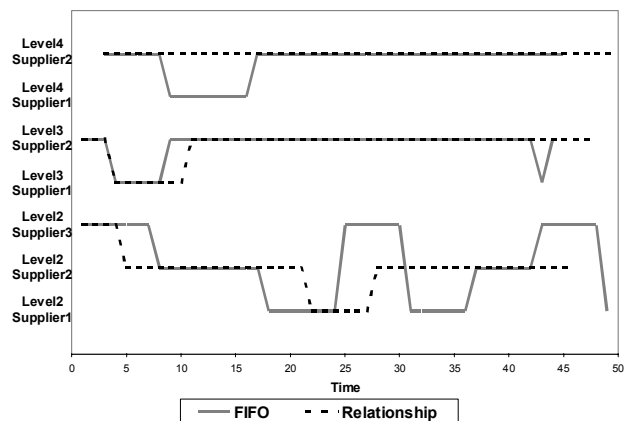

Figure 9: Supplier switches for different order fulfillment policies

Figure 9 supports the assumption that the use of a relationship-based order fulfillment strategy (dotted line) leads to a more stable supply chain structure. Not only the total number of supplier switches is smaller, also preferences become fixed earlier. Using the relationship-based strategy every agent has a preferred customer whose orders are fulfilled first. This customer rates the agent as more attractive as its delivery time is smaller—delivery time is one of the variables that determine supplier attractiveness. Therefore the customer will more easily stick to this supplier: preferences become fixed.

## 5.2. Variation of attractiveness decay time

A second experiment is conducted to analyze the effect of a change in the *attractiveness decay time*. As described in section 4 the *attractiveness decay* reflects the degree to which an agent values the past performance of its suppliers; a higher *attractiveness decay time* leads to a slower decay of attractiveness and therefore to a stronger focus on past supplier performance. In section 5.1 an *attractiveness decay time* of 24 has been used for the simulation experiments. Now the two extreme scenarios of an *attractiveness decay time* of 1 respective 100 are compared; the FIFO strategy is used as order fulfillment strategy. The results are depicted in Figure 10 and Figure 11.

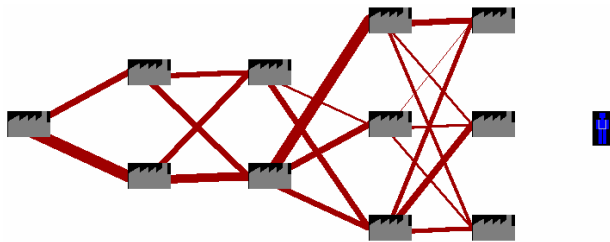

Figure 10: Attractiveness decay time=1

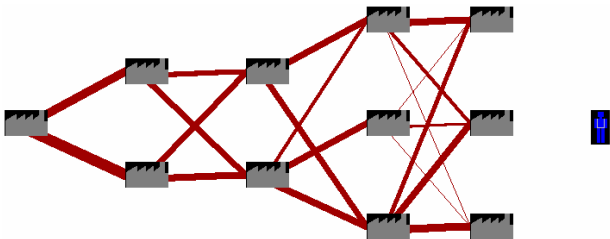

Figure 11: Attractiveness decay time=100

This time no definite conclusion can be drawn by looking at the aggregate system structure. The same number of potential links is realized for both scenarios. Therefore, again the preferred supplier for one agent on ever supply chain level is compared for the two scenarios (Figure 12).

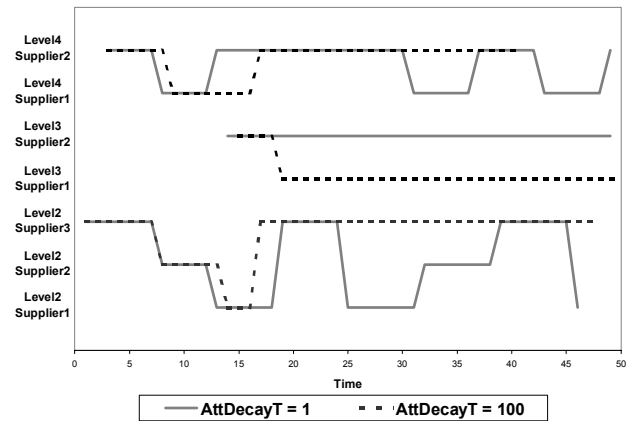

Figure 12: Supplier switches for different attractiveness decay time

Figure 12 shows that a high *attractiveness decay time* that is a stronger focus on past performance, has a similar effect like a relationship-based order fulfillment policy: it leads to the emergence of a more stable system structure. This can be explained by the fact that when considering past performance an agent does not switch supplier as soon as its current supplier has difficulties to deliver on time. Primarily after a longer period of poor performance or in the beginning of a relationship—no historic data are available—switches are taken place. Therefore, in a model without major disturbances—like the one described here—, switches tend to occur in an early stage of the simulation.

## 6. Conclusion and further research

System Dynamics is an approach for the modeling and simulation of nonlinear dynamic systems that aims at the understanding of a system's structure and the deduction of the behavior from it. This focus on understanding is a great advantage of the system dynamics methodology as it is a requirement for the development of policies that lead to the improvement of the system's performance. On the other hand in a system dynamics model the structure has to be determined before starting the simulation and can not be changed during the course of a simulation experiment. The analyses of certain questions however, require the structure to be flexible. A supply chain is an excellent example of a dynamic system with a flexible structure. A company in a supply chain can switch from one supplier to another or suppliers can enter or exit the market. In this paper a hybrid modeling approach was presented that intends to make the system dynamics approach more flexible by combining it with the discrete agent-based modeling approach. This is done by the



coupling of the two software environments Vensim® and eM-Plant® in a hierarchical model.

The approach is applied to a simple four-level supply chain comprising ten agents. Two simulation experiments are conducted using different order fulfillment and supplier evaluation policies. Our results do not entirely correspond with Ackermans' findings who states that the relative preferences for a specific supplier become fixed in an early stage of the simulation run. However, in contrast to Ackermans we compare two supply chains with identical agents. So in a next step the model has to be simulated using individual agents with different policies within one chain. The comparison of these results with Ackermans findings could then give some more prove of the validity of the approach.

Other areas of further research include model extensions: The model described in this paper is prototypical—it comprises only ten agents. More agents have to be included in the model and conditions have to be defined for agents to enter or exit the market during the course of the simulation. Finally the two external sources have an extremely simplified behavior: the producer fulfills orders with a fixed time delay of two periods, independent from the quantity of materials to be provided; the external customer places a fixed order at every level one supplier. This oversimplified behavior could be improved by making part of the behavior endogenous. The external customer could be given an evaluation module so that it can choose the supplier to order from; for the producer the production process could be modeled.

## References

- [1] Akkermans, Henk A., P. Bogerd and Bart Vos (1999). Virtuous and Vicious Circles on the Road Towards International Supply Chain Management. *International Journal of Operations and Production Management*, Vol. 19, Nos. 5/6, pp. 565–581.
- [2] Akkermans, Henk A. (2001). Emergent Supply Networks: System Dynamics Simulation of Adaptive Supply Agents. Paper presented at the 34th Hawaii International Conference on System Sciences, Hawaii.
- [3] Anderson, Edward G., Jr., Charles H. Fine and G.G. Parker (2000). Upstream Volatility in the Supply Chain: The Machine Tool Industry as a Case Study. *Production and Operations Management*, Vol. 9, No. 3, pp. 239–261.
- [4] Anderson, Philip (1999). Complexity Theory and Organization Science. *Organization Science*, Vol. 10, No. 3, pp. 219–232.
- [5] Angerhofer, Bernard J. and Marios C. Angelides (2000). System Dynamics Modeling in Supply Chain Management: Research Review. J.A. Joines, R.R. Barton, K. Kang and P.A. Fishwick (eds.), *Proceedings of the 2000 Winter Simulation Conference*, pp. 342–351.
- [6] Bonabeau, Eric (2002). Predicting the Unpredictable. *Harvard Business Review*, March 2002, pp. 109–116.
- [7] Brehmer, Berndt (1992). Dynamic Decision Making: Human Control of Complex Systems. *Acta Psychologica*, Vol. 81, pp. 211–241.
- [8] Choi, Thomas Y., Kevin J. Dooley, and M. Rungtusanatham (2001). Supply networks and complex adaptive systems: control versus emergence. *Journal of Operations Management*, Vol. 19, No. 3, pp. 351–366.
- [9] Dörner, Dietrich (1996). *The Logic of Failure*. New York: Metropolitan Books/Henry Holt.
- [10] Forrester, Jay W. (1958). Industrial Dynamics: A Major Breakthrough for Decision Makers. *Harvard Business Review*, Vol. 36, No. 4, pp. 37–66.
- [11] Forrester, Jay W. (1961). *Industrial Dynamics*. Cambridge: MIT Press.
- [12] Forrester, Jay W. (1994). Policies, Decisions, and Information Sources for Modeling. John D.W. Morecroft and John D. Sterman (eds.), *Modeling for Learning Organizations*. Portland: Productivity Press, pp. 51–84.
- [13] Metz, P.J. (1998). Demystifying Supply Chain Management. *Supply Chain Management Review*, Vol. 2, No. 4, pp. 46–55.
- [14] Milling, Peter and Andreas Größler (2001). Management von Material- und Informationsflüssen in Supply Chains: System-Dynamics-basierte Analysen. Working Paper Series, Faculty of Business Administration, Mannheim University, No. 2001-01.
- [15] Morecroft, John D.W. (1994). Executive Knowledge, Models, and Learning. John D.W. Morecroft and John D. Sterman (eds.), *Modeling for Learning Organizations*. Portland: Productivity Press, pp. 3–28.
- [16] Parunak, H. Van Dyke, Robert Savit and Rick L. Riolo (1998). Agent-Based Modeling vs. Equation-Based Modeling: A Case Study and User' Guide. *Proceedings of Multi-agent systems and Agent-based Simulation*, pp. 10–25.
- [17] Phelan, Steven E. (1999). A Note on the Correspondence between Complexity and Systems Theory. *Systemic Practice and Action Research*, Vol. 12, No. 3, pp. 237–246.
- [18] Phelan, Steven E. (2001). What is complexity science, really? *Emergence*, Vol. 3, No. 1, pp. 120–136.



- [19] Pidd, Michael (1993). *Computer Simulation in Management Science*, 3rd edition. Chichester: John Wiley.
- [20] Pol, Jurgen M. van der and Henk A. Akkermans (2000). 'No one in the driver's seat': An agent-based modeling approach to decentralised behaviour in supply chain coordination. Pre-Prints 11th International Working Seminar on Production Economics, Vol. 3, pp. 621–643.
- [21] Richardson, George P. (1991). *Feedback Thought in Social Science and Systems Theory*. Philadelphia: University of Pennsylvania Press.
- [22] Scholl, Hans J. (2001a). Agent-based and System Dynamics Modeling: A Call for Cross Study and Joint Research. Proceedings of the 34th Hawaiian International Conference on Systems Science, Wailea.
- [23] Scholl, Hans J. (2001b). Looking Across the Fence: Comparing Findings From SD Modeling Efforts With those of Other Modeling Techniques. Proceedings of the 19th International Conference of the System Dynamics Society, Atlanta.
- [24] Senge, Peter M. (1990). *The Fifth Discipline. The Art and Practice of the Learning Organization*. New York: Currency & Doubleday.
- [25] Sterman, John D. (1989). Misperceptions of Feedback in a Dynamic Decision Making Experiment. *Management Science*, Vol. 35, No. 3, pp. 321–339.
- [26] Sterman, John D. (2000). *Business Dynamics. Systems Thinking and Modeling for a Complex World*. Boston: McGraw-Hill.
- [27] Towill, Denis R. (1996a). Industrial Dynamics Modelling of Supply Chains. *Logistics Information Management*, Vol. 9, No. 4, pp. 43–56.
- [28] Towill, Denis R. (1996b). Time Compression and Supply Chain Management—a Guided Tour. *Supply Chain Management*, Vol. 1, No. 1, pp. 15–27.

---

i. Phelan (1999) does not distinguish between system dynamics and general systems' theory. This fact, however, is not discussed in the context of this paper.