

Emotional Responses to a Romantic Partner's Imaginary Rejection: The Roles of Attachment Anxiety, Covert Narcissism, and Self-Evaluation

Avi Besser¹ and Beatriz Priel²

¹Sapir Academic College

²Ben-Gurion University of the Negev

ABSTRACT These studies tested the associations between responses to an induced imaginary romantic rejection and individual differences on dimensions of attachment and covert narcissism. In Study 1 ($N = 125$), we examined the associations between attachment dimensions and emotional responses to a vignette depicting a scenario of romantic rejection, as measured by self-reported negative mood states, expressions of anger, somatic symptoms, and self-evaluation. Higher scores on attachment anxiety, but not on attachment avoidance, were associated with stronger reactions to the induced rejection. Moreover, decreased self-evaluation scores (self-esteem and pride) were found to mediate these associations. In Study 2 ($N = 88$), the relative contributions of covert narcissism and attachment anxiety to the emotional responses to romantic rejection were explored. Higher scores on covert narcissism were associated with stronger reactions to the induced rejection. Moreover, covert narcissism seemed to constitute a specific aspect of attachment anxiety.

Attachment theory posits that early relationships with caregivers lead to the incorporation of internal working models into the developing personality structure, guiding the formation of expectations

We acknowledge all of the research assistants and blind judges from Sapir Academic College and Ben-Gurion University of the Negev for their invaluable assistance with the data collection. Grateful thanks are extended to all the participants in this study. Finally, we thank Dr. Christopher Leone and the anonymous reviewers for their constructive suggestions.

Correspondence concerning this article should be addressed to Avi Besser, Ph.D., Department of Behavioral Sciences, Sapir Academic College, D. N. Hof Ashkelon, 79165, Israel. E-mail: besser@mail.sapir.ac.il.

Journal of Personality 77:1, February 2009

© 2009, Copyright the Authors

Journal compilation © 2009, Wiley Periodicals, Inc.

DOI: 10.1111/j.1467-6494.2008.00546.x

and behavior in future relationships (Bowlby, 1969, 1973, 1980). The concept of internal working models of attachment has been proposed as a cognitive and affective construct that includes the individual's memories, perceptions, and expectations in relation to significant others. According to Bowlby these internal working models include expectations about the self as worthy of love and attention (the model of the self) and about others as supportive and responsive (the model of the other), as well as the relationship between these two. Working models of self and other are proposed to have enduring impacts on an individual's self-evaluation, interpersonal perceptions, and behavior across the life span (e.g., Bartholomew, 1990; Bowlby, 1973; Colin, 1996). A growing body of empirical research has extended the study of attachment beyond childhood (Bartholomew & Horowitz, 1991; Hazan & Shaver, 1987), theorizing that the quality of early attachments might have long-term repercussions on many aspects of adult life such as the ability to maintain long-term, intimate relationships. Persons with secure childhood attachments are expected to exhibit higher levels of trust, closeness, and dependability, whereas insecure childhood attachments are expected to have the opposite effect (Brennan & Shaver, 1998; Feeney & Ryan, 1994).

In the last years a main body of attachment research furthers the conceptualization of internal working models of attachment underscoring the ways they affect the attachment system; this research proposes two main dimensions along which individual differences in attachment can be assessed: attachment anxiety and attachment avoidance (Brennan, Clark, & Shaver, 1998; Cassidy & Kobak, 1988; Mikulincer & Shaver, 2003, 2007). A person's position in each of these *orthogonal* dimensions indicates his or her sensitivity to potential threats of rejection or lack of responsiveness and the extent to which proximity is looked for or avoided in order to cope with these threats. Low scores on both dimensions characterize the security attachment style whereas insecure attachment is defined by high scores on one or both dimensions. High scores in the anxiety versus the avoidance dimension have been explained as expressing different strategies in the intent to cope with insecurity: the hyperactivation of the attachment system by increasing proximity (attachment anxiety) on one hand or the deactivation of the attachment system through the avoidance of contact (attachment avoidance) on the other hand.

Attachment Dimensions and Affect Regulation

Research on adult attachment has provided evidence of the relationship between attachment styles and emotional self-regulation among adolescents and adults (Bartholomew & Horowitz, 1991; Mikulincer, Shaver, & Pereg, 2003). From this perspective, attachment styles can be viewed as organized rules that guide the individual's responses in situations of distress. Kobak and Sceery (1988) suggested that secure persons tend to manage distress effectively and also tend not to be depressed, whereas persons reporting insecure attachment styles use less effective coping strategies, leading to distress and depression. Insecure patterns of attachment are associated in adult clinical and community samples with relatively high levels of distress (e.g., Besser & Priel, 2003; Besser, Priel & Wiznitzer, 2002; Priel & Shamai, 1995; Roberts, Gotlib, & Kassel, 1996), depression (e.g., Murphy & Bates, 1997), anxiety (e.g., Mikulincer, Florian, & Weller, 1993), general distress symptoms (e.g., Lopez, Mitchell, & Gormley, 2002), and negative affect (e.g., Simpson, 1990). In particular, anxious attachment styles have been found to predict distress and depression (e.g., Besser & Priel, 2005; Wei, Mallinckrodt, Russell, & Abraham, 2004). On the other hand, working models characteristic of secure attachment have been found to reduce susceptibility to depression and negative affectivity (e.g., Carnelley, Pietromanco, & Jaffe, 1994).

Whereas individuals high on the attachment-anxiety dimension tend to intensify negative emotional states and exaggerate the threatening aspects of an event, those high on the attachment-avoidant dimension tend to distance themselves from emotional situations (see Mikulincer & Shaver, 2007, and the references therein). A plausible explanation of the association between attachment anxiety and greater distress when confronted with rejection may center on the vulnerability of these individuals' self-evaluation. Moreover, previous research supports the hypothesis that anxiously attached people's self-worth is especially dependent on other's approval (Anderson & Peris, 2000; Park, Crocker, & Mickelson, 2004). In the present studies, we investigate the role played by self-evaluations and narcissistic orientations in the attachment anxiety/heightened distress associations.

The Model of the Self and Attachment Theory

From its onset, attachment theory emphasized the basic association between the attachment figure's responses and the subject's

self-evaluation. Hazan and Shaver (1994) discussed Bowlby's mental model and stated that, "attachment theory thus implies that beliefs and feelings about the self, especially social and global self-esteem, are determined in part by the responsiveness of the caregiving environment" (p. 5). Bartholomew and Horowitz (1991) characterized the self-model underlying attachment styles as reflecting a sense of lovability or being worthy of love (positive self-dimension). Empirical evidence strengthened this position, documenting the associations between attachment styles and self-esteem (e.g., Collins & Read, 1990; Feeney & Noller, 1990). Griffin and Bartholomew (1994a, 1994b) showed that the positivity of an individual's attachment self-model is highly related to the positivity of her or his self-evaluation, with self-esteem as one of the indicators of self-evaluation.

A major empirical finding in this field has been the identification of important associations between attachment anxiety and low self-esteem, offering support for the hypothesis that attachment anxiety constitutes a risk factor for fluctuations in the self-model. Moreover, it has been shown that anxious adult attachment styles are associated with dysfunctional attitudes, which in turn predispose for lower levels of self-esteem (Roberts et al., 1996). Thus, attachment anxiety appears to lead to symptoms of heightened distress in adulthood through its impact on self-worth and self-esteem. Following this line of thought, we proposed that associations between attachment anxiety and the increase of negative responses following the rejection of a romantic partner might be mediated by extensive changes in the self-evaluation.

STUDY 1: THE MEDIATING ROLE OF CHANGES IN SELF-EVALUATION

Overview

Existing research supports the hypothesis that the development of, and change in, the attachment system affects the formation of the self-evaluation (Cassidy, 1988, 1990). It has been noted that a sense of security with an attachment figure seems to instill a person with a positive self-image that allows the individual to feel good about him- or herself in a variety of adjustment areas, including social relationships (Offer, Ostrov, Howard, & Dolan, 1992). Attachment anxiety has been found to associate with lower global self-esteem (Bartholomew & Horowitz, 1991; Mickelson, Kessler, & Shaver, 1997) as well as with the attribution of negative traits to the self (Mikulincer,

1995). Results about the association between self-esteem and attachment avoidance are less clear: Attachment avoidance has been associated with inflated self-evaluations in some studies (e.g., Mikulincer, 1995, 1998a), but Brennan and Morris (1997) found that attachment avoidance predicts lower self-evaluations in social domains. Recent research on levels of self-esteem and the attachment dimensions of anxiety and avoidance reveals a link between high attachment anxiety and unstable self-esteem, whereas attachment avoidance was unrelated to self-esteem stability (Foster & Kernis, 2007).

To further the understanding of the associations between self-esteem and attachment anxiety, in Study 1 we aimed at the investigation of the associations between individual differences in insecure attachment and changes in expressions of negative affectivity, anger, and somatic symptoms, as well as changes in aspects of the self (self-esteem and self-pride) in response to an interpersonal threat. Specifically we hypothesized that levels of attachment anxiety will be positively associated with increased negative mood and negative affective reactions, because induced imaginary romantic rejection might have the potential to hyperactivate attachment anxiety-related worries (e.g., worry that the partners will reject them, abandon them, or judge them unworthy of love) but may not affect avoidance attachment-related themes (e.g., uneasiness with interdependency and dismissiveness of intimacy). The second goal of this study was to investigate the role of self-evaluation in the link between attachment anxiety and affective experiences and distress responses to romantic rejection. Specifically, we hypothesized that the association between attachment anxiety and negative mood outcomes, in response to the imaginary romantic rejection, is mediated by significant decreases in the self-evaluation (self-esteem and self-pride).

The hypothesis that threatened self-esteem could act as a mediator between threats to a romantic relationship and negative affect is supported by work on the role of self-esteem in interpersonal relationships. It has been noted that one of self-esteem's central functions is to provide an ongoing gauge of one's status vis-à-vis relationship partners (Leary & Baumeister, 2000). Correspondingly, many emotions related to functioning within the context of interpersonal relationships have been shown to involve awareness and appraisals of self (Tracy & Robins, 2004).

In the present study, we intend to further the investigation of the association of attachment anxiety with general negative affectivity

by (a) including additional assessments of other specific negative reactions, namely, anger expressions and somatic symptoms and (b) exploring the mediating role of low self-evaluation, in particular, the changes in, or stability of, self-esteem and pride in response to the induced threat of rejection.

Attachment Anxiety, Anger, and Somatic Symptoms

Bowlby (1988) suggested that anger behaviors are ways in which infants communicate to their parents that their attachment system is activated (e.g., at times of separation, pain, and fatigue) and that their attachment needs are not being satisfied. This is a “functional anger,” and it allows parents to respond to their child’s attachment needs (Bowlby, 1977). A history of insecure attachment interactions may transform a child’s functional anger into aggressive behavior in an attempt to reestablish proximity. Empirical results have corroborated the association between violent behavior (e.g., aggressive and oppositional behavior toward peers and caregivers, disruptive behavior disorders, controlling interactions with others) and child insecure attachment (Greenberg, DeKlyen, Speltz, & Endriga, 1997; Lyons-Ruth, Alpern, & Repacholi, 1993).

A similar association between insecure attachment and expressions of dysfunctional anger has been postulated and investigated for adults’ attachment dimensions. Attachment anxiety has been found to lead to “adult proneness to react with extreme anger when relevant attachment cues are present” (Dutton, 1995, p. 574). Individuals high on attachment anxiety dimension were found to be more likely to express dysfunctional anger because of their chronic anxiety over rejection and abandonment in close relationships. Moreover, in an extensive study, Mikulincer (1998b) showed that secure attachment was related to lower anger proneness, more constructive anger goals, more adaptive responses and more positive affect in anger episodes, lower hostile intent to others, and more positive expectation outcomes from anger episodes, as compared with insecure attachment styles. On a more speculative level one may expect that attachment avoidance will effect a suppression of anger among other negative emotions, whereas attachment anxiety may increase negative emotionality (Mikulincer & Shaver, 2007).

In addition to their direct expressions of anger and distress, anxiously attached individuals may generally be more likely to report

somatic symptoms as a consequence of their tendencies to focus on negative affect (Feeney & Ryan, 1994). Based on a review of research on childhood antecedents and personality contributions to somatoform disorders as well as research on social influences during adulthood, Stuart and Noyes (1999) hypothesized that somatizing patients display anxious attachment behavior that derives from childhood experiences with caregivers. Early exposure to illness increases the likelihood that distress will be manifested somatically. When under stress as adults, somatizers use physical complaints to elicit care. Somatizers' interpersonal interactions with others, including physicians, ultimately lead to rejection that reinforces the somatizer's belief that he or she will be abandoned. At the same time, this anger may serve an ego-protective purpose (Berman & Sperling, 1994). The experience and expression of anger through somatization may help insecure men and women alleviate their insecure attachment.

Based on the literature reviewed above, we proposed that higher levels of attachment anxiety will lead individuals scoring high in the attachment anxiety dimension to report more intense negative affect, anger, and somatization. We proposed that the anxiety over abandonment that is implied in the anxiety dimension of adult attachment would be associated with increased negative affectivity (anxiety, depression, and hostility), as well as with the specific reactions of anger expressions and somatic symptoms. Moreover, we expected that these reactions to an induced imaginary romantic rejection would also be associated with a less positive self-evaluation. Finally, our main hypothesis is that a more negative self-evaluation will mediate the associations between attachment anxiety and negative affect, anger, and somatization in response to an induced imaginary romantic rejection.

Method

Participants

Our sample consisted of 125 Israeli nonclinical community sample participants (63 men, 62 women) who each reported being currently involved in a serious committed romantic relationship. Participants responded to a call for volunteers to take part in a study of personality and mood. Participants were young adults in their mid-20s (range 20–30; $M = 24.78$, $SD = 2.51$). All participants had more than 12 years of formal education ($M = 13.41$, $SD = 1.63$).

Measures and Procedure

Participation in the study was voluntary (i.e., participants were not paid or compensated in any other way). Participants were asked if they were currently involved in a serious committed romantic relationship and if they would be willing to complete a questionnaire about personality and relationships. Only those currently involved in a serious committed romantic relationship and who agreed to take part in the study were invited to first and second sessions. All participants were reminded of their right to withdraw from the study should they feel uncomfortable. None chose to do so. After the second session, they were given a written debriefing.

The study was conducted in two separate sessions. For a random 50% of the participants, the first session took place at the beginning of the week and the second session took place 3 days later. For the other half of the participants, the first session took place at the end of the week and the second session followed 3 days later. Participants reported individually to a psychology laboratory, where they were informed that this was a study of the relationship between personality and behaviors that occur in the context of romantic relationships. During the first session participants completed a measure of attachment dimensions and baseline measurements of pride and self-esteem, anger, somatic symptoms, and of their current state negative mood were taken. The order of presentation of the questionnaires was randomized. In the second session, participants read a vignette of a hypothetical scenario intended to evoke the threat of romantic rejection. After this reading, the participants were asked to rate their current feelings and experiences in response to the hypothetical scenario in terms of how they were feeling at the moment (i.e., “How do you feel now?”) measured using the VAS (Albersnagel, 1988), the State Anger Scale (STAS; Spielberger, Jacobs, Russell, & Crane, 1983), the SCBAI-Somatic Subscale (Lehrer & Woolfolk, 1982), and measures of state self-esteem and pride. Potential order effects were controlled by means of randomized presentation of the questionnaires at each time of measurement.

Induced threat of romantic rejection. In a pilot study, 10 independent judges, blind to the study’s aims, rated four different scenarios for their capacity to evoke a threat of romantic rejection on a 7-point scale (*not at all* [1] to *very much* [7]). The judges rated the four scenarios in random order. Judges observed an acceptable level of intraclass correlation reliability. Judges established acceptable levels of inter-rater intraclass correlation reliability coefficients (Shrout & Fleiss, 1979) for the ratings of the four scenarios ($ICC > .90$). Among these scenarios, the one used in the present study achieved the significantly highest mean scores for its capacity to evoke a threat to a romantic relationship and also achieved the

significantly highest intraclass correlation reliability and mean scores when coders evaluated these situations on the following item: "This situation closely matches the definition of betrayal¹ and a threat of loss of, or being rejected by, a romantic partner" (1 = *strongly disagree*, 5 = *strongly agree*).

Using a procedure similar to the one described by Buss, Larsen, Westen, & Semmelroth (1992), participants were instructed to "Please think of a serious committed romantic relationship that you currently have, have had in the past, or would like to have in the future."²

Next, participants were asked to imagine the following scenario:³

You get out of work early one day and decide to surprise your partner with a present. As you walk up to the apartment, you hear laughing coming from inside. As you get closer, you see that the door is cracked open. You open the door to find X and another person having sexual relations in the living room. You hear X whispering to this person, "I think I might be in love."

Negative state mood. Current (i.e., "How do you feel now?") negative state mood was measured before and after exposure to the scenario using the three negative affective state scales of the VAS (Albersnagel, 1988). These scales include 14 negative mood adjectives. Participants were asked to indicate how they were feeling "at the moment" by placing a vertical mark on each 80-mm line anchored at 0% and 100%, with opposing labels for each adjective (e.g., *not at all sad* to *extremely sad*). The three affective states assessed were *dysphoria* (depressed, sad, blue, desponded,

1. According to Drigotas and Barta (2001), *betrayal* is defined as "a partner's violation of norms regulating the level of emotional or physical intimacy with people outside the relationship" (p. 177). Betrayal can be sexual, emotional, or both. Sexual betrayal is any behavior that involves sexual contact, such as kissing, intimate touching, oral sex, or sexual intercourse. Emotional betrayal involves the formation of an emotional attachment or affection for another person and can involve such behaviors as flirting, dating, intimate conversations, or falling in love.

2. This was used in order to capture more general tendencies rather than responses related to a specific current or previous relationship.

3. This procedure was validated in a pilot study, with an independent nonclinical community sample of 134 Israeli volunteers (63 men, 71 women ages 20–29 $M = 24.19$, $SD = 2.22$). All participants had more than 12 years of formal education ($M = 13.27$, $SD = 1.40$) and reported that they were currently involved in a serious committed romantic relationship. As expected, participants' ratings of their current negative state mood levels after experiencing an induced rejection were significantly higher than their baseline levels. Accordingly, we adopted this method for our two studies.

tormented, and lost), *hostility* (hostile, irritable, annoyed, and disagreeable), and *anxiety* (anxious, nervous, uneasy, and tense).

Adult romantic attachment. We used the Experiences in Close Relationships–Revised Measure (ECR-R; Fraley, Waller, & Brennan, 2000) to evaluate participants' self-reported romantic attachment dimensions. This scale contains 36 items derived from an item response theory (IRT) analysis of most of the existing self-report measures of adult romantic attachment (see Brennan et al., 1998). The ECR-R measures scores along two subscales, *avoidance* (or *discomfort with closeness and discomfort with depending on others*) and *anxiety* (or *fear of rejection and abandonment*). (See Fraley et al., 2000, for more information on scoring.)

Self-esteem. Global self-esteem levels were measured before and current/state self-esteem levels (i.e., "How do you feel now?") were assessed after the presentation of the romantic rejection scenario using the Single-Item Self-Esteem Scale (SISE; Robins, Hendin, & Trzesniewski, 2001). Before and after reading the scenario, participants rated the item, "I see myself as someone who has high self-esteem," on a 5-point Likert scale, ranging from 1 (*strongly disagree*) to 5 (*strongly agree*). For reliability and validity information for this measure, see Robins et al. (2001).

Self-pride. Global self-pride levels were measured before and current/state self-pride levels (i.e., "How do you feel now?") were assessed after the presentation of the romantic rejection scenario. Participants responded to a statement designed to capture their overall self-pride. Participants rated the item, "I see myself as someone who has high self-pride," on a 5-point Likert scale, ranging from 1 (*strongly disagree*) to 5 (*strongly agree*).

In the present study, we hypothesized that state self-esteem and pride would change following the imaginary interpersonal rejection, not because self-image/esteem per se is important, but rather because self-esteem is a measure of acceptance and may potentially reflect internal representation of the imaginary rejection.

Anger responses. Current/state anger (i.e., "How do you feel now?") was measured before and after exposure to the rejection scenario, using the State Anger Scale (STAS; Spielberger et al., 1983). This scale is designed to measure the intensity of anger that a person experiences. The State Anger Scale is a 15-item scale that uses a 4-point Likert format. Items were rated for intensity of current feeling and experiences, from *not at all* (1) to *very much* (4). Scores are the sums of the responses to the state-anger items. High scores indicate that a person is more likely to respond with elevated levels of transient anger. For reliability and validity information for this measure, see Spielberger et al. (1983).

Somatic symptoms. The somatic subscale of the Somatic, Cognitive, and Behavioral Anxiety Inventory was used to measure current/state (i.e., "How do you feel now?") somatic symptoms before and after the presentation of the rejection scenario (SCBAI-Somatic Subscale; Lehrer & Woolfolk, 1982). The SCBAI assesses the level and type of discomfort feelings participants are currently experiencing. The somatic subscale of the SCBAI includes 16 items on a 9-point Likert scale dealing with somatic expressions of distress. For reliability and validity information for this scale, see Lehrer & Woolfolk (1982).

Cronbach's α values obtained in the present study for the multi-item scales are reported in Table 1.

Results and Discussion

As expected, and confirming the findings of our preliminary pilot study, the ratings that participants gave their negative state mood levels after exposure to the induced imaginary romantic rejection situation were significantly higher than the baseline levels, $F(1, 124) = 144.1, p < .0001, \eta_p^2 = .54$ for anxiety, $F(1, 124) = 496.48, p < .0001, \eta_p^2 = .80$ for dysphoria, and $F(1, 124) = 179.78, p < .0001, \eta_p^2 = .59$ for hostility. Moreover, participants' ratings of their anger expressions, $F(1, 124) = 411.54, p < .0001, \eta_p^2 = .77$, and somatic symptoms were significantly higher after the exposure to the rejection scenario, $F(1, 124) = 132.42, p < .0001, \eta_p^2 = .52$. Finally, participants' ratings of their own state self-esteem, $F(1, 124) = 183.28, p < .0001, \eta_p^2 = .60$, and pride, $F(1, 124) = 106.77, p < .0001, \eta_p^2 = .46$, were significantly lower after the experience of the induced imaginary romantic rejection. Means and standard deviations are presented in Table 1.

The Mediation Hypothesis

Do decreased levels of self-esteem and pride in response to the induced imaginary romantic rejection mediate the association between attachment anxiety and increased negative affect, anger expressions, and somatic symptoms?

To examine the association between attachment anxiety and negative affect, defined as a latent factor and including all three simultaneously assessed negative affect measures, we used a Structural Equation Modeling (SEM; Hoyle & Smith, 1994) strategy that allowed us to evaluate this association while assessing measurement errors in the dependent and independent variables and the auto-correlations among

Table 1

Correlations Among Attachment Dimensions and Properties of Interest Before and After the Induced Threat of Romantic Rejection (Study 1).

	1	2	3	4	5	6	7	8	9	10	11	12	13	14	15	16
1. AnxAtt	—															
2. AvdAtt	.23**	—														
3. Anxiety-before	.41***	.19*	—													
4. Dysphoria-before	.33***	.24**	.56***	—												
5. Hostility-before	.23**	-.00	.49***	.46***	—											
6. Anxiety-after	.35***	-.02	.26**	.15	.05	—										
7. Dysphoria-after	.38***	.12	.23**	.16	.10	.73***	—									
8. Hostility-after	.27**	.02	.21*	.08	.08	.70***	.64***	—								
9. Ang. expressions-before	.24**	.24**	.45***	.47***	.33***	.13	.10	.04	—							
10. Ang. expressions-after	.16	.03	.13	.06	-.06	.55***	.62***	.68***	-.07	—						
11. Somatic symp.-before	.25**	.34***	.37***	.29***	.19*	.05	.12	-.01	.39***	.08	—					
12. Somatic symp.-after	.27**	.04	.28**	.17	.09	.50***	.56***	.46***	.16	.46***	.18*	—				
13. Self-esteem-before	-.15	-.12	-.07	-.16	.03	-.08	-.21*	-.01	-.02	.00	-.04	-.16	—			
14. Self-esteem-after	-.25**	-.08	-.13	-.09	-.08	-.46***	-.58***	-.35***	-.02	-.49***	-.19*	-.37***	.20*	—		
15. Pride-before	-.03	-.04	-.15	-.08	.04	-.10	-.13	-.09	.03	.04	-.03	-.09	.59***	.20*	—	
16. Pride-after	-.35***	-.02	-.14	-.07	.04	-.50***	-.61***	-.43***	-.03	-.56***	-.08	-.39***	.11	.67***	.01	—
α	.87	.88	.86	.90	.85	.89	.90	.81	.93	.91	.89	.87	—	—	—	—
<i>M</i>	3.51	2.64	23.39	11.59	22.60	38.37	53.52	42.14	18.37	42.16	21.99	46.51	3.78	1.78	3.411.59	—
<i>SD</i>	0.97	0.86	7.78	13.00	9.45	13.80	18.75	14.01	4.91	12.00	8.14	24.00	1.08	1.50	1.261.52	—

Note: $N = 125$. AnxAtt = anxiety attachment. AvdAtt = avoidant attachment. Ang. = anger, symp. = symptoms.

* $p < .05$. ** $p < .01$. *** $p < .0001$.

errors in repeated self-reported measures (see Figure 1). SEM analysis was performed with the AMOS software (Version 4.0; Arbuckle, 1999), using the maximum-likelihood method. We used the χ^2 statistic as a fit index to evaluate how the “proposed” model (i.e., the model being evaluated) fits the data as compared to the “saturated” model (i.e., the baseline model that represents perfect model fit). A nonsignificant χ^2 has traditionally been used as a criterion for not rejecting an SEM model; a nonsignificant χ^2 indicates that the discrepancy of the matrix of the parameters estimated based on the model being evaluated is not different from the one based on the empirical data. However, this is a very strict, sensitive criterion that is influenced by the number of variables and participants (e.g., Landry, Smith, Swank, & Miller-Loncar, 2000). We therefore used additional fit indices.⁴

Table 1 presents the intercorrelations between the study variables.⁵ These data were provided to depict the first order correlations

4. Model fit was assessed using the following indices: χ^2 divided by degrees of freedom (χ^2/df), the Non-Normed Fit Index (NNFI; Bentler & Bonett, 1980), the Comparative Fit Index (CFI; Bentler, 1990), and the Root Mean Square of Approximation (RMSEA; Steiger, 1980). Although a nonsignificant p value has traditionally been used as a criterion for not rejecting an SEM, this criterion is overly strict and sensitive for models with many variables (Kelloway, 1998). Therefore, in the present study, alternative criteria that reflect real-world conditions were also used. A model in which χ^2/df was ≤ 2 , CFI and NNFI were each greater than 0.90, and the RMSEA index was between 0.00 and 0.06 with confidence intervals between 0.00 and 0.08 (Hu & Bentler, 1998, 1999) was deemed acceptable. These moderately stringent acceptance criteria clearly reject inadequate or poorly specified models while accepting for consideration models that meet real-world criteria for reasonable fit and representation of the data (Kelloway, 1998).

5. Although self-esteem and attachment have traditionally been examined from different perspectives, an overlap between these two constructs has been implicitly assumed, and even demonstrated, by some researchers (e.g., Cassidy, 1990). Attachment styles and self-esteem variables are highly correlated. In this case, neither may contribute significantly to the model after the other one is included, but together they contribute much and might lead to misleading inferences. If this happens, the attachment styles and self-esteem variables are *collinear* and the results show *multicollinearity*. To ensure that attachment styles and self-esteem variables, although highly correlated, did not both convey essentially the same information, multicollinearity diagnostic analyses were performed. Eigenvalues of the scaled and uncentered cross-products matrix, condition indices, and variance-decomposition proportions along with variance inflation factors (VIF) and tolerances from a multicollinearity diagnostic analyses indicated the absence of the multicollinearity problems; thus attachment styles and pre- and postexposure self-esteem measures are not redundant.

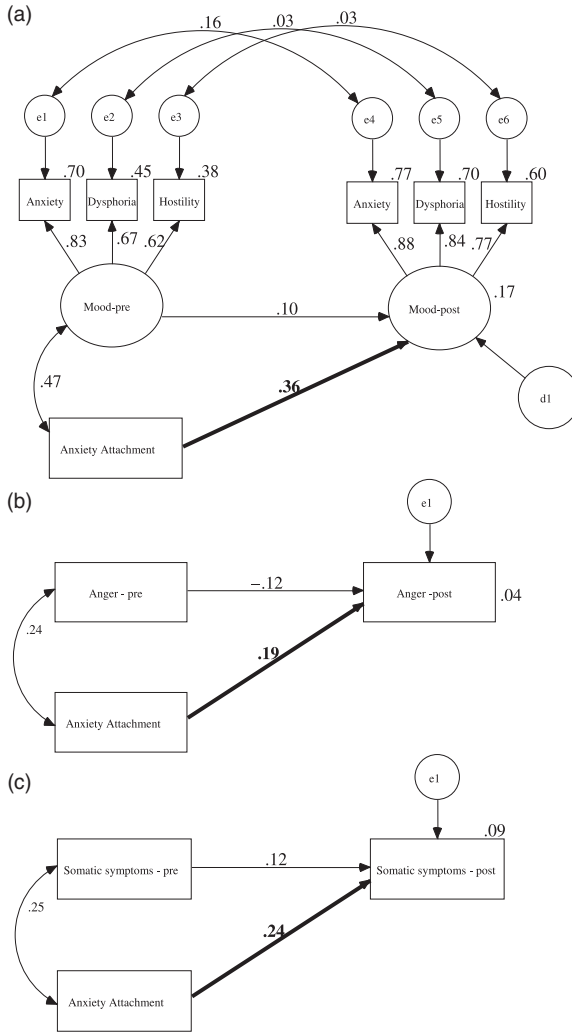

Figure 1

The direct association models (Study 1). Rectangles indicate measured variables and large circles represent latent constructs. Small circles reflect residual (e) or disturbance (d). Numbers above or next to endogenous variables represent the amount of variance explained (R^2). Bidirectional arrows depict correlations and unidirectional arrows depict hypothesized directional, "causal" links. Standardized maximum likelihood parameters are used. Bold estimates are statistically significant. Pre = before induction and post = after induction.

among the separate observed indicator variables that are not shown through the assessment of the relations among the latent construct and observed measures examined in the structural model presented in the figures. It is important to note here that series of Hierarchical Multiple Regressions with attachment anxiety, attachment avoidance, and their product term (interaction) on each of the outcome variables in response to the induced imaginary romantic rejection while controlling for their baseline levels demonstrated that it is *only* the attachment anxiety, not the attachment avoidance, that was found to correlate significantly with the outcome measures.

Analytic Strategy

Initially, we followed Baron and Kenny's (1986) criteria for mediation, according to which (a) there must be a significant association between the predictor and criterion variables and (b) in an equation including both the mediator and the criterion variable, there must be a significant association between the predictor and mediator, and the mediator must be a significant predictor of the criterion variable. If the significant, direct relationship between the predictor and the criterion variables in the equation that includes both the mediator and the predictor variable declines, the obtained pattern is consistent with the mediation hypothesis. If the direct association approaches zero, the mediator can be said to fully (although not necessarily exclusively) account for the relationship between the predictor and the criterion (Baron & Kenny, 1986).

Accordingly, in the following analyses, we first analyzed the models of the direct association between attachment anxiety and changes in negative affect (anxiety, dysphoria, and hostility), anger expressions, and somatic symptoms (see Figure 1).⁶ Then, the models of the direct and indirect associations between attachment anxiety and these outcome variables through reports of changes in self-evaluation (self-esteem and pride) were specified (see Figure 2). We controlled for associations relating to the errors (auto-correlations) of

6. When adding the avoidance scores and Avoidance \times Attachment anxiety interaction (product term) to the examined model, it was *only* the attachment anxiety that related significantly to outcomes.

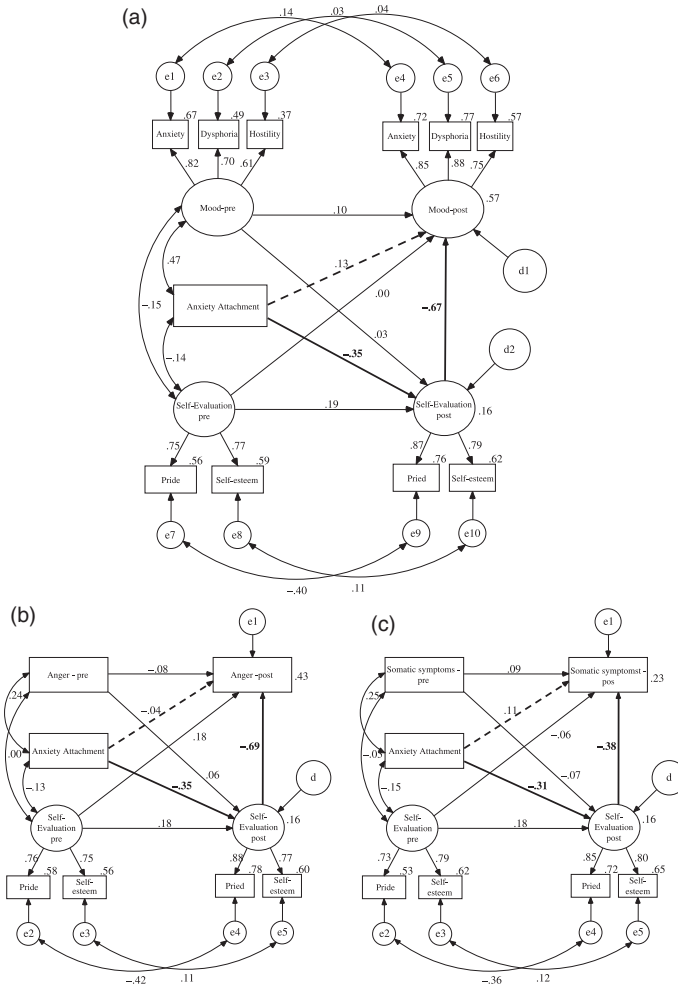

Figure 2

The indirect association models (Study 1). Rectangles indicate measured variables and large circles represent latent constructs. Small circles reflect residual (e) or disturbance (d). Numbers above or next to endogenous variables represent the amount of variance explained (R^2). Bidirectional arrows depict correlations and unidirectional arrows depict hypothesized directional, "causal" links. Standardized maximum likelihood parameters are used. Bold estimates are statistically significant. The dotted path indicates a significant drop in the direct path from attachment anxiety to changes in outcome scores when changes in self-evaluation scores are included in the model. Pre = before induction and post = after induction.

measurements relating to the same report source for pre- and post-exposure measures of negative affects and for self-esteem and pride. Moreover, our design allowed us to control for, and estimate the associations between, the Time 1 measure of self-evaluation and the Time 2 affective outcome and the associations between the Time 1 measure of affective outcome and self-evaluation at Time 2.

Analyses of the specified mediational models fit the data very well: $\chi^2 = 46.132$, $df = 33$, $\chi^2/df = 1.398$, $p = .06$, NNFI = 0.919, CFI = 0.974, and RMSEA = 0.05 for changes in negative mood; $\chi^2 = 6.053$, $df = 6$, $\chi^2/df = 1.009$, $p = .417$, NNFI = 0.997, CFI = 1.000, and RMSEA = 0.008 for changes in anger expressions; and $\chi^2 = 9.672$, $df = 6$, $\chi^2/df = 1.612$, $p = .139$, NNFI = 0.995, CFI = 0.998, and RMSEA = 0.06 for changes in somatic symptoms. Mediation occurs when the indirect association of a predictor and an outcome, through a mediator, significantly reduces the predictor's direct association with the outcome (Baron & Kenny, 1986). Once we controlled for the change in self-evaluation, the declines in the coefficients of the direct paths from attachment anxiety (predictor) to change in outcomes were significant according to z' statistical tests ($z' = 2.80$, $p < .01$, $z' = 3.09$, $p < .01$, $z' = 2.44$, $p < .01$, and $z' = 2.21$, $p < .01$ for negative mood, anger expressions, and somatic symptoms, respectively). The indirect association significantly contributed (40%, 39%, 14%, and 23%) to the variance in negative mood, anger expressions, and somatic symptoms, respectively.

However, although Baron and Kenny's (1986) recommendations are influential and widely cited, some recent criticism has been raised (see MacKinnon, Lockwood, Hoffman, West, & Sheets, 2002), especially in regard to their use of Sobel's (1982) Large Sample Test to examine the significance of the indirect association. Therefore, in the following analyses, we also investigated the sampling variability of estimates of the indirect association, using the *bootstrap* framework recently adapted for use in mediation in SEM by Shrout and Bolger (2002) and Mallinckrodt, Abraham, Wei, and Russell (2006).⁷ Using

7. There has been considerable controversy about the best way to estimate the standard error used in the significance test. There are numerous approaches to calculation of standard errors and a recent paper by MacKinnon et al. (2002) includes a thorough review and comparison of these different approaches. This paper reports the results from a Monte Carlo study of a variety of methods for testing the significance of indirect effects and examined the Type I and Type II error rates of each. Although most of the approaches controlled Type I errors

options in AMOS, we implemented this procedure in the mediational models, which involved drawing 1,000 bootstrapping samples. We found that 100% of the bootstrap samples converged for all of the models analyzed. As shown in Table 2, the 95% confidence intervals and the C.I. based on the bias-corrected bootstrap for the direct and indirect associations in our models are consistent with the conclusion that the direct and indirect associations are significantly different from zero. These results suggest that our procedure led to a stable estimate of the distributions.

Our results suggest that, after controlling for baseline levels of state negative affectivity, individuals high on the attachment anxiety dimension are particularly vulnerable to increased psychological distress in response to an imaginary romantic rejection situation. This increased vulnerability might be linked to the more negative representations of self that were found to characterize the anxious attachment dimension (Bartholomew & Horowitz, 1991; Brennan et al., 1998). These findings are in line with Cassidy and Kobak's (1988) findings about the hyperactivation of the attachment systems among anxiously attached people. Hyperactivation is indicated by recurrent attempts to minimize distance from attachment figures eliciting their support. It also includes the hyperactivation of negative emotions and thoughts, as well as the persistence of psychological pain. Our findings are also congruent with previously reported empirical results that have described the tendencies of anxiously attached individuals to focus on their own distress, ruminate on negative thoughts, and adopt emotion-focused coping strategies that exacerbate, rather than diminish, distress (e.g., Birnbaum, Orr, Mikulincer, & Florian, 1997; Mikulincer & Florian, 1995; Pistole, 1995).

It is important to note that our findings point to attachment anxiety as a plausible predictor of changes in self-evaluation and affective outcomes beyond its associations with Time 1 measures of affective reactions and self-evaluation. Moreover, none of the Time 1 measures of self-evaluation had significant associations with changes in affective reactions. Also, none of the Time 1 measures of affective reactions significantly related to self-evaluation scores at Time 2.

well, they did differ in their statistical power. An alternative approach recently proposed by Shrout and Bolger (2002) uses bootstrapping for estimating standard errors and may have greater power.

Table 2
Standard and Bootstrap Methods for Mediation (Study 1)

Effect	Estimate			Bootstrap			BC confidence			
	SE	CR	p <	SE	SE-SE	Bias	SE-Bias	Lower	Upper	p <
Negative mood										
a. AnAtt → Negative Mood	1.305	3.442	.001	1.542	.034	.028	.049	1.476	7.813	.002
b. AnAtt → Self-Evaluation	0.136	-3.100	.002	0.143	.003	.008	.005	-0.732	-0.151	.004
c'. Self-Evaluation → Negative Mood	1.072	-6.173	.0001	1.397	.031	-.081	.044	-9.814	-4.321	.002
Indirect effect										
a × b				1.135				0.823	5.533	.005
Anger expressions										
a. AnAtt → Anger expressions	1.120	2.076	.038	1.168	.026	.042	.037	0.000	4.537	.050
b. AnAtt → Self-Evaluation	0.119	-3.497	.0001	0.134	.003	.001	.004	-0.700	-0.168	.003
c'. Self-Evaluation → Anger expressions	1.118	-6.355	.0001	1.293	.029	-.292	.041	-10.040	-5.078	.004
Indirect effect										
a × b				1.090				1.027	5.216	.004
Somatic symptoms										
a. AnAtt → somatic symptoms	2.188	2.760	.006	2.051	.046	.105	.065	2.138	10.357	.003
b. AnAtt → Self-Evaluation	0.123	-3.159	.002	0.148	.003	.018	.005	-0.682	-0.098	.011
c'. Self-Evaluation → somatic symptoms	2.076	-3.655	.0001	2.450	0.055	-.047	.077	-12.999	-3.023	.006
Indirect effect										
a × b				1.622				0.512	7.562	.013

Note: Based on 1,000 bootstrap samples. AnxAtt = anxiety attachment. AvdAtt = avoidant attachment. BC confidence = Biased-Corrected Confidence Intervals (95%).

These results suggest that we can be reasonably confident that the defined associations are the results of attachment anxiety responses to changes *following* the induced imaginary romantic rejection of method.

Our analyses indicate that changes in self-evaluation in response to an induced romantic rejection mediate the association between high attachment anxiety and increased negative affective reactions (anxiety, dysphoria, hostility, anger expressions, and somatic symptoms). Overall, the results of the mediating model support previous findings (Mikulincer, Orbach, & Iavnieli, 1998), which described the tendency of individuals high in the attachment anxiety dimension to react to threatening situations by devaluing themselves.

The results of Study 1 point to the negative representation of the self (inherent in attachment anxiety) as a specific vulnerability factor to induced partner rejection. These findings suggest that the known reduced self-esteem that results from anxiously attached persons' perceptions of rejection may be one of the mechanisms that hyperactivate negative emotions and thoughts. The crucial role that aspects of self-evaluation play in this model suggests an important similarity to patterns described in the current literature on narcissism. Moreover, the findings of Study 1 suggest a possible overlap between attachment anxiety and narcissism. Study 2 was designed to explore this possibility.

STUDY 2: NEGATIVE REACTIONS TO AN INDUCED ROMANTIC REJECTION: THE ROLES OF ATTACHMENT ANXIETY AND COVERT NARCISSISM

Overview

Self-derogating tendencies among individuals positioning high in the attachment anxiety dimension result in overly negative self-evaluations that have been associated with pathological forms of narcissism (e.g., Dickinson & Pincus, 2003; Pistole, 1995). Whereas attachment avoidance was assumed to associate with extremely positive self-representations and *overt* narcissism or grandiosity (Gabbard, 1998; Wink, 1991), attachment anxiety, in contrast, seems to predispose a person to, or to accompany, *covert* narcissism, which is characterized

by self-focused attention (i.e., hypersensitivity to other people's evaluation of oneself; Hendin & Cheek, 1997; Wink, 1991).

Study 2 addressed the contributions of attachment anxiety and covert forms of narcissism to negative affective responses in a non-clinical population within the context of the induced imaginary romantic rejection. Specifically, we intended to explore whether the association between attachment anxiety and distress reactions to an imaginary romantic rejection is specific to the attachment system only or if it reflects specific narcissistic elements that have been found to be associated with adult attachment anxiety.

Beyond theoretical differences, the term *narcissism* can be seen as related to cognitive-affective patterning or to the structure of the intrapsychic self (Blanck & Blanck, 1979; Kernberg, 1985; Kohut & Wolf, 1978). Morf and Rhodewalt (2001) defined narcissism as a personality process based on a grandiose yet vulnerable self-concept. A person with a healthy self is assumed to be able to regulate affect internally, sustain interpersonal relationships, and differentiate and value the self and significant others (Pistole, 1995). When the self-structure is fragile, the person has more difficulty maintaining an inner sense of comfort and esteem and so is more easily wounded or hurt (i.e., more narcissistically vulnerable) and more dependent on the esteem, confirmation, and comforting of others. Like attachment theory, this conceptualization of narcissism addresses issues of self-esteem, interpersonal relationships, and affects regulation in both health and illness (see Armstrong & Roth, 1989; Belsky & Nezworski, 1988; Bowlby, 1988; West & Sheldon, 1988). However, attachment theory centers on interpersonal relationships and representations, whereas research on narcissism encompasses issues of self-regard and inner resources. Attachment theory sees working models of self as deriving from interpersonal relationship patterns and intended to secure these relationships. Theories of narcissism see interpersonal relationships as serving the patterning of the representation of the self. Both of these perspectives consider negative self-representation to be a basic personality vulnerability that can affect the regulation of affect and the quality of interpersonal relationships. The findings from Study 1 suggest that our understanding of insecure attachment, particularly its anxiety dimension, can be enriched by taking into account the perspective of narcissism and narcissistic strategies intended to protect a vulnerable self-representation.

In recent years, research in social and clinical psychology has begun to explore the relationship between adult attachment styles and forms of narcissism. Important similarities can be found in the description of parenting patterns of individuals high in the anxiety dimension and narcissistic individuals. Caregivers of anxiously attached infants tend to be inconsistently responsive to their infant's needs, being sometimes unavailable and, at other times, intrusive and/or overprotective. For instance, Cassidy and Berlin (1994) suggested that whereas caregivers of anxious infants are unavailable when their infants seek attention, they are more involved when their infants are engaged in autonomous play (see also Isabella & Belsky, 1991). A similar inconsistency is characteristic of the patterns of parenting experienced by narcissistic individuals.

A few recent studies compared attachment anxiety and narcissistic personality structures. The anxiety dimension of attachment has been found to include strong narcissistic elements, such as the need to idealize the partner (Feeney & Noller, 1990; Hazan & Shaver, 1987), hypervigilance to cues of separation, and greater distress over separation (Mikulincer, Kedem, & Paz, 1990). Strategies related to attachment anxiety seem to mainly serve the needs of a depleted self and not those of the relationship (see also Mikulincer, Paz, & Kedem, 1990). Dickinson and Pincus (2003) have reported a strong link between covert narcissism and anxious (or fearful) styles of adult attachment, as well as a weaker link with attachment avoidance. Smolewska and Dion (2005) report compelling evidence on the association between covert narcissism and the anxiety dimension of romantic attachment; these authors assume a close association between feelings of self-unworthiness and attachment anxiety. No detectable relationship between overt narcissism and avoidant attachment style was observed in this study. Also Otway and Vignoles (2006) have shown, in a nonclinical sample, that recollections of parental overvaluation or parental coldness contributed positively to the prediction of narcissism, beyond levels of insecure attachment. On the basis of a study of childhood recollections these authors reported a strong association between anxious attachment and covert narcissism, but concluded that covert narcissism cannot be equated with attachment anxiety. In the present study we aimed at evaluating the extent and quality of the associations between attachment anxiety and covert narcissism using a design that assesses affective responses to a present threat.

Study 2 was conducted to investigate the relative contributions of the attachment anxiety dimension and covert narcissistic personality traits to the negative affective responses elicited by an imaginary romantic rejection. Specifically, Study 2 was designed to test the hypothesis that narcissism and attachment anxiety are two related yet different personality constructs that associate with strong negative responses to the induced imaginary romantic rejection.

Method

Participants

Our sample consisted of 88 Israeli nonclinical participants (38 men, 50 women) who reported that they were currently involved in a serious committed romantic relationship. Participants responded to our call for volunteers to take part in a study of personality and mood. Participants were a community sample of young adults in their mid-20s (range 20–29; $M = 24.07$, $SD = 2.46$). All participants had more than 12 years of formal education ($M = 13.23$, $SD = 1.38$).

Measures and Procedure

Procedures were the same as those used in the pilot study and in Study 1, except that participants also completed a measure of narcissism (HSNS; Hendin & Cheek, 1997) during the first session. In the second session, participants read the vignette (the hypothetical scenario used in the pilot study and in Study 1) that was intended to evoke the threat of romantic rejection, and then completed questionnaires intended to measure specific reactions to the vignette, in terms of negative state mood, anger expressions, and somatic symptoms. Potential order effects within the presentations of the questionnaires, both before and after exposure to the vignette, were controlled for by the randomized presentation of the different questionnaires. Attachment dimensions (ECR-R; Fraley et al., 2000), negative affective states (VAS; Albersnagel, 1988), anger (STAS; Spielberger et al., 1983), and somatic symptoms (SCBAI; Lehrer & Woolfolk, 1982) were measured using the same questionnaires used in Study 1.

Narcissism. Covert narcissism was measured using the Hypersensitive Narcissism Scale (Hypersensitive Narcissism Scale [HSNS]; Hendin & Cheek, 1997). The HSNS is composed of 10 items that are rated using a 5-point, Likert-type scale (1 = *very uncharacteristic or untrue, strongly disagree* to 5 = *very characteristic or true, strongly agree*). These items were

selected from a narcissism scale originally developed by Murray (1938; as cited by Hendin & Cheek, 1997) so as to converge closely with a composite of two MMPI scales identified as measures of covert narcissism (see Rose, 2002). However, compared to the MMPI measures, the HSNS has much greater face validity, reflecting the original source of the items. Items measure recognizable features of covert narcissism, such as self-absorption (e.g., “I can easily become entirely absorbed in thinking about my personal affairs, my health, my cares, or my relations to others”) and hypersensitivity (e.g., “My feelings are easily hurt by ridicule or the slighting remarks of others”). For reliability and validity information for this measure, please see Gleason, Jarudi, & Cheek, 2003 and Meier, 2004).

Cronbach’s α values obtained in the present study for the multi-items scales are reported in Table 3.

Results and Discussion

As expected, and confirming the findings of Study 1, participants’ ratings of their negative state mood levels were significantly higher after the experience of the threat of romantic rejection—evoking situation (induced romantic partners’ betrayal), relative to their baseline levels, $F(1, 87) = 61.114, p < .0001, \eta_p^2 = .41$ for anxiety, $F(1, 87) = 257.524, p < .0001, \eta_p^2 = .75$ for dysphoria, and $F(1, 87) = 140.420, p < .0001, \eta_p^2 = .62$ for hostility. Confirming the findings of Study 1, participants’ ratings of their anger expressions, $F(1, 87) = 333.298, p < .0001, \eta_p^2 = .80$, and somatic symptoms were significantly higher after the experience of the threat of romantic rejection, $F(1, 87) = 108.938, p < .0001, \eta_p^2 = .56$. Means and standard deviations are presented in Table 3.

Predicting Change in Negative Affectivity

To explore this question, the associations between attachment anxiety and narcissism and negative outcomes were explored using SEM (Hoyle & Smith, 1994) strategy that allows for the evaluation of the attachment anxiety—covert narcissism link while assessing measurement errors in the dependent and independent variables and auto-correlations among errors in repeated, self-reported measures. All SEM analyses were performed with the AMOS software (Version 4.0; Arbuckle, 1999), using the maximum-likelihood method.

Table 3
Correlations Among Attachment Dimensions, Narcissism, and Distress Evaluations Before and After the Induced Threat of Romantic Rejection (Study 2)

	1	2	3	4	5	6	7	8	9	10	11	12	13
1. AnxAtt	—												
2. AvdAtt	.11	—											
3. Covert Narcissism	.47***	.07	—										
4. Anxiety-before	.26*	-.10	.11	—									
5. Dysphoria-before	.24*	.03	.10	.59***	—								
6. Hostility-before	.08	-.04	.00	.62***	.57***	—							
7. Anxiety-after	.43***	.11	.30**	.15	.16	.13	—						
8. Dysphoria-after	.40***	-.01	.34***	.08	.04	.02	.74***	—					
9. Hostility-after	.31**	.06	.34***	.18	.08	.14	.62***	.76***	—				
10. Ang. expressions-before	.01	.07	-.08	.58***	.62***	.52***	-.05	-.13	-.01	—			
11. Ang. expressions-after	.42***	.03	.29**	.06	.07	.04	.64***	.65***	.68***	.03	—		
12. Somatic symp.-before	.11	-.01	-.01	.53***	.55***	.55***	.05	-.07	-.04	.58***	.05	—	
13. Somatic symp.-after	.42***	.04	.30**	.17	.06	.10	.60***	.59***	.46***	-.01	.60***	.18	—
α	.85	.87	.82	.90	.87	.86	.91	.83	.90	.89	.85	.88	.84
<i>M</i>	3.63	2.66	27.19	24.55	14.85	22.03	38.81	56.04	42.57	18.49	43.67	24.88	56.14
<i>SD</i>	1.04	.80	4.80	10.80	16.61	9.86	14.95	18.17	14.40	6.23	11.43	13.62	27.19

Note: *N* = 88. AnxAtt = anxiety attachment. AvdAtt = avoidant attachment. Ang. = anger, symp. = symptoms.

p* < .05. *p* < .01. ****p* < .0001.

Table 3 presents the intercorrelations between the study variables.⁸ These data were provided to depict the first-order correlations among the separate observed indicator variables that are not available through the assessment of the relations among the latent construct and observed measures examined in the structural models presented in the figures. It is important to note here that, as in Study 1, series of Hierarchical Multiple Regressions with attachment anxiety, attachment avoidance, and their product term (interaction) on each of the outcome variables in response to the induced imaginary romantic rejection while controlling for their baseline levels demonstrated that it is *only* attachment anxiety, but not attachment avoidance, that was found to significantly correlate with outcome measures.

As in Study 1, we analyzed the association between attachment anxiety and change in negative mood. The specified models (see Figure 3a) fit the data very well: $\chi^2 = 13.805$, $df = 11$, $\chi^2/df = 1.255$, $p = 0.244$, NNFI = 0.949, CFI = 0.989, and RMSEA = 0.05. We then analyzed the association of narcissism and change in negative mood. The specified models (see Figure 3b) fit the data very well: $\chi^2 = 9.307$, $df = 11$, $\chi^2/df = 0.846$, $p = 0.594$, NNFI = 0.964, CFI = 1.000, and RMSEA = 0.001. Finally, we analyzed the combined associations of attachment anxiety and narcissism and change in negative mood. The specified models (see Figure 3c) fit the data very well: $\chi^2 = 15.660$, $df = 15$, $\chi^2/df = 1.044$, $p = 0.405$, NNFI = 0.948, CFI = 0.998, and RMSEA = 0.02. The significant association between narcissism and change in negative affectivity ($\beta = .37$, $t = 3.390$, $p < .001$) declined and became nonsignificant when attachment anxiety was included in the

8. Although narcissism and attachment have traditionally been examined from different perspectives, recent research suggests the two constructs may share a similar underlying structure (Brennan & Shaver, 1998; Feintuch, 1999). Attachment styles and narcissism variables are highly correlated. In this case, neither may contribute significantly to the model after the other one is included and might lead to misleading inferences. If this happens, the attachment styles and narcissism variables might be *collinear* and the results show *multicollinearity*. To ensure that attachment styles and narcissism variables, although highly correlated, do not both convey essentially the same information, multicollinearity diagnostic analyses were performed. Eigenvalues of the scaled and uncentered cross-products matrix, condition indices, and variance-decomposition proportions along with VIF and tolerances from a multicollinearity diagnostic analyses indicated the absence of the multicollinearity problems; thus attachment styles and narcissism measures are not redundant.

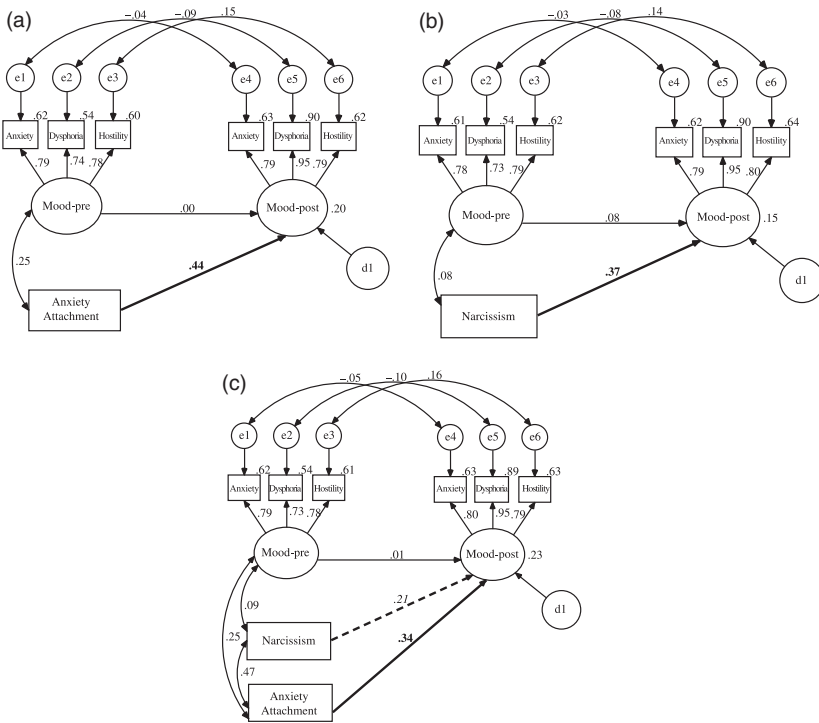

Figure 3

Anxiety attachment and covert narcissism associations with change in negative affect (Study 2). Rectangles indicate measured variables and large circles represent latent constructs. Small circles reflect residual (e) or disturbance (d). Numbers above or next to endogenous variables represent the amount of variance explained (R^2). Bidirectional arrows depict correlations and unidirectional arrows depict hypothesized directional or “causal” links. Standardized maximum likelihood parameters are used. Bold estimates are statistically significant. Pre = before induction and post = after induction.

model ($\beta = .21, t = 1.884, ns$), and the association between attachment anxiety and change in negative affectivity remained significant ($\beta = .34, t = 2.838, p < .005$). Thus, attachment anxiety was found to be a significant predictor of change in negative affectivity beyond narcissism.

Predicting Change in Anger Expressions and Somatic Symptoms

After controlling for baseline levels of anger expression, we found that narcissism significantly predicted change in anger expression

following romantic rejection ($\beta = .29$, $t = 2.78$, $p < .007$). When attachment anxiety was included in the model, narcissism no longer predicted change in anger expressions following romantic rejection ($\beta = .12$, $t = 1.05$, *ns*). After controlling for baseline levels of somatic symptoms, narcissism significantly predicted change in somatic symptoms following romantic rejection ($\beta = .30$, $t = 3.00$, $p < .004$). When attachment anxiety was included in the model, narcissism no longer predicted change in somatic symptoms following romantic rejection ($\beta = .15$, $t = 1.31$, *ns*). Thus, attachment anxiety was found to be a significant predictor of change in both anger expressions and somatic symptoms following romantic rejection, beyond the associations between narcissism and these changes.

The results of Study 2 support our findings involving the associations between attachment anxiety and changes in negative affectivity, anger expressions, and somatic symptoms in response to the threat of romantic rejection. Moreover, Study 2 also demonstrates an important association between narcissism and anger.⁹ Although the discussion between attachment and narcissism theories centers mostly on the relative importance of interpersonal versus intrapsychic models of development and adult functioning, the empirical data seem to resist this dichotomy. Interpersonal, as well as intrapsychic, processes may not be exclusive (see also Bateman & Fonagy, 2003; Blatt & Levy, 2003) and may both contribute to a person's response to a threat to an attachment relation. In our study across all three dependent measures, narcissism was no longer associated with changes in affect once attachment anxiety was entered in the models, indicating that both attachment behavior and narcissistic tendencies may be active in the production of negative responses to a romantic rejection and suggesting that an individual's position in the attachment anxiety dimension may constitute one of the sources of covert narcissistic tendencies.

These findings linking attachment anxiety to covert narcissism may help to partially explain the difference between various concep-

9. In both studies, when the avoidance scores and Avoidance \times Attachment anxiety interaction (product term) were included in the models, it was *only* the attachment anxiety that related significantly to outcomes. Moreover, in Study 2, we also included the Attachment anxiety \times Narcissism interaction in the examined models and found that this interaction did not contribute significantly to the prediction of any of the outcomes.

tualizations of the associations between narcissism and attachment anxiety and avoidance. Whereas some authors have reported that attachment avoidance is the main factor in vulnerability to narcissism (e.g., Blatt & Levy, 2003), others have claimed that narcissism is determined by the attachment anxiety dimension (Dickinson & Pincus, 2003; Mikulincer, Kedem, et al., 1990; Mikulincer, Paz et al., 1990; Smolewska & Dion, 2005).

GENERAL DISCUSSION

The current work describes the results of two studies in which non-clinical community sample participants experienced an imaginary threat of romantic rejection. Their responses were assessed in terms of changes in the level of state negative affect, self-esteem, pride, and anger expressions, as well as somatic symptoms.

The findings of these studies underscore the importance of attachment anxiety to psychological vulnerability vis-à-vis a threat of potential disruption of a romantic relationship. Our study suggests that participants positioning high on the attachment anxiety dimension are particularly vulnerable to the threat of romantic rejection. Moreover, high levels of attachment anxiety are associated not only with low self-esteem, they also seem to play an important role in the nonadaptive management of distressful interpersonal situations.

Even though a causal design was not investigated in the studies presented, the obtained pattern of findings on the *changes* that occurred in the evaluations of the participant's negative affect, anger, symptoms, and self-evaluations is consistent with a specific direction in the relationship between psychological distress and self-esteem. Our results indicate that fear of rejection, or of not deserving the love of a significant other, results in further distress, but not the other way around. That is, participants' initial levels of distress did not associate with more negative initial levels of self-evaluation. Thus, although people with higher attachment anxiety scores are likely to experience lower levels of self-esteem and higher levels of psychological distress, in general, our findings suggest that it is lowered self-evaluation (esteem and pride) that plays an essential role in the feelings of anger, distress, and vulnerability experienced in response to the induced imaginary rejection by, or potential loss of, a significant other.

Our findings in regard to the link between interpersonal rejection and one's self-evaluation and psychological distress are in line with previous studies of young adults, which found that attachment anxiety is associated with the oversignaling of involvement and relationship needs, as well as with an inability to accurately perceive others' commitment (Guerrero & Burgoon, 1996). One possible explanation for the link between the induced imaginary romantic rejection and a lowered self-evaluation might be the tendency of individuals high on the attachment anxiety dimension to repeatedly seek reassurance. Recent research reports that excessive reassurance-seeking behavior mediates depressive symptoms among anxiously attached young adults (Shaver, Schachner, & Mikulincer, 2005). Further studies might also include the incorporation of measures of general (pre-event) and specific (postevent) excessive reassurance-seeking behavior into our model, allowing us to estimate the role of increased, excessive reassurance-seeking behavior as an additional mediator of negative change in the self-evaluation and increased negative psychological outcomes.

Our studies allowed for some discrimination between the contributions of attachment anxiety and covert narcissism to the strong negative responses provoked by the imaginary rejection of a romantic partner. Although these two constructs (attachment anxiety and covert narcissism) are associated with each other, each makes a specific contribution to affect regulation. However, our findings support a model according to which it is the attachment anxiety that accounts for the association of narcissistic tendencies with increased vulnerability in the context of interpersonal rejection. On a more speculative level, our findings seem to support a conceptualization of attachment anxiety as a basic construct that may strongly affect covert narcissism scores, emphasizing the fundamental role of interpersonal experience in structuring personality vulnerabilities.

Limitations and Further Directions

General Limitations and Suggestions

Some potential limitations of our research should be mentioned. Given that our study focused on relatively young adults, it is not clear if the present findings can be generalized to older adults or other populations. It would be valuable to examine the relations

among attachment anxiety, self esteem/pride, and negative affective outcomes in more diverse populations and different racial/ethnic groups. In addition, although in the present work prior gender mean differences and differences in the correlations were not postulated, they were nevertheless explored post hoc, in light of the fact that previous research has suggested that men and women may differ in their responses to the infidelity of a romantic partner. An impressive body of research has been devoted to testing the hypothesis that women respond with stronger negative emotions to their mates' emotional infidelity, whereas men generate stronger negative emotions in response to sexual infidelity. This hypothesis has received considerable empirical support, especially as measured by self-reports of emotional distress using a forced-choice response format (Buss et al., 1992). However, recent research on this issue (Harris, 2003, 2005) has proposed a lack of gender differences. In congruence with these findings, no significant gender differences were observed in the present study. One possible explanation may be that the situation used in our study did not clearly differentiate between these two possibilities (i.e., emotional infidelity vs. sexual infidelity). Further research might explore the proposed model while presenting clearly demarcated situations of romantic rejection or a committed relationship due to either emotional or sexual infidelity, and extend the model to include the role played by gender. An important additional variable to be included in further research is the quality of the current romantic relationship as it may interact with personality and distress variables.

Methodological Caveats and Suggestions Relating to Causal Processes

Our models cannot provide a definitive answer to the question of the direction of the effects (Spencer, Zanna, & Fong, 2005) of self-concept and affective outcomes variables, nor can it be compared to the proposed alternative reversed effects model (i.e., the possibility that attachment anxiety affects mood thereby activating mood process that impact self esteem) because these are known as *equivalent* models that can not be statistically compared. Consequently we proposed the direction of the effects according to theoretical underpinnings. The empirical demonstration of the mediational effects would need an enhanced longitudinal design (Cole & Maxwell, 2003). Even though two

waves of measurement provide a good indication of the direction of effects, mediational effects are best tested with three waves of data (e.g., T1 predictor → T2 mediator → T3 outcome; Cole & Maxwell, 2003) that allow us to separate the mediator not only from the predictor but also from the outcome, increasing possible causal inferences (Shrout & Bolger, 2002).

The design used in the present studies did not allow us to explore the possible moderational effects of attachment anxiety. The exploration of such a model would need a randomized study design that also includes a nonthreat group. When threat and nonthreat conditions are included, one can define the effect of the threat condition on mood or other outcomes and then examine whether individuals with high attachment anxiety are more affected by the threat than those who are more secure. The lack of a nonthreat control group in our study also prevented the testing of a moderational model in the framework of “differential choice–differential effectiveness models” (Bolger & Zuckerman, 1995). Bolger and Zuckerman tested this “*differential exposure-reactivity*” model that assumes that certain personality dispositions may make high-scoring individuals opt for certain preferred coping modes that in turn are especially effective for them. Accordingly, in further investigations in this area it is important to use a longitudinal design with three waves of data (for the estimation of predictors, mediators, and outcomes) and randomized experiments, manipulating interpersonal stress (e.g., rejection and neutral conditions) and estimating as well as manipulating attachment security (e.g., using priming). This design would allow for a more direct estimation of the question of whether people high in the dimension of attachment anxiety who encounter stressful events (e.g., rejection or relationship threat), experience them as more aversive and react with higher levels of negative affect than those low in this trait as well as whether these effects are mediated by these individuals’ lowered self-concept (esteem) resulting from the encounter with these stressful events.

In summary, despite their limitations, using a pre/post design, the present studies support a view of attachment anxiety as promoting maladaptive affect regulation strategies in response to the lowering of self-evaluation in the context of romantic rejection. Moreover, our findings also indicate that both attachment behavior and narcissistic tendencies may be active in the production of overtly neg-

ative responses to a romantic rejection and suggest that high scores in the attachment anxiety dimension may constitute one of the sources of covert narcissistic tendencies.

REFERENCES

- Albersnagel, F. A. (1988). Velten and musical mood induction procedures: A comparison with accessibility of thought associations. *Behaviour Research and Therapy*, **26**, 79–96.
- Anderson, P., & Perris, C. (2000). Attachment styles and dysfunctional assumptions in adults. *Clinical Psychology and Psychotherapy*, **7**, 47–53.
- Arbuckle, J. L. (1999). *Amos: A structural equation modeling program*. Chicago: Small Waters.
- Armstrong, J., & Roth, D. M. (1989). Attachment and separation difficulties in eating disorders: A preliminary investigation. *International Journal of Eating Disorders*, **8**, 141–155.
- Baron, R. M., & Kenny, D. A. (1986). The moderator-mediator variable distinction in social psychological research: Conceptual, strategic, and statistical considerations. *Journal of Personality and Social Psychology*, **51**, 1173–1182.
- Bartholomew, K. (1990). Avoidance of intimacy: An attachment perspective. *Journal of Social and Personal Relationships*, **7**, 147–178.
- Bartholomew, K., & Horowitz, L. M. (1991). Attachment styles among young adults: A test of a four-category model. *Journal of Personality and Social Psychology*, **61**, 226–244.
- Bateman, A., & Fonagy, P. (2003). The development of an attachment-based treatment program for borderline personality disorder. *Bulletin of the Menninger Clinic*, **67** (3), 187–211.
- Belsky, J., & Nezworski, T. (Eds.). (1988). *Clinical implications of attachment*. Hillsdale, NJ: Erlbaum.
- Bentler, P. M. (1990). Comparative fit indexes in structural models. *Psychological Bulletin*, **107**, 238–246.
- Bentler, P. M., & Bonett, D. G. (1980). Significance tests and goodness of fit in the analysis of covariance structures. *Psychological Bulletin*, **88**, 588–606.
- Berman, W. H., & Sperling, M. B. (1994). The structure and function of adult attachment. In M. B. Sperling & W. H. Berman (Eds.), *Attachment in adults: Clinical and developmental perspectives* (pp. 3–28). New York: Guilford Press.
- Besser, A., & Priel, B. (2003). A multisource approach to self-critical vulnerability to depression: The moderating role of attachment. *Journal of Personality*, **71**, 515–555.
- Besser, A., & Priel, B. (2005). The apple does not fall far from the tree: Attachment styles and personality vulnerabilities to depression in three generations of women. *Personality and Social Psychology Bulletin*, **31**, 1052–1073.
- Besser, A., Priel, B., & Wiznitzer, A. (2002). Childbearing depressive symptomatology in high-risk pregnancies: The roles of working models and perceived spouse support. *Personal Relationships*, **9**, 395–413.

- Birnbaum, G. E., Orr, I., Mikulincer, M., & Florian, V. (1997). When marriage breaks up: Does attachment style contribute to coping and mental health? *Journal of Social and Personal Relationships*, **14**, 643–654.
- Blanck, G., & Blanck, R. (1979). *Ego psychology II: Psychoanalytic developmental psychology*. New York: Columbia University Press.
- Blatt, S., & Levy, K. (2003). Attachment theory, psychoanalysis, personality development, and psychopathology. *Psychoanalytic Inquiry*, **23**, 102–150.
- Bolger, N., & Zuckerman, A. (1995). A framework for studying personality in the stress process. *Journal of Personality and Social Psychology*, **69**, 890–902.
- Bowlby, J. (1969). *Attachment and loss: Vol. 1. Attachment*. Harmondsworth: Penguin.
- Bowlby, J. (1973). *Attachment and loss: Vol. 2. Separation*. New York: Basic.
- Bowlby, J. (1977). *The making and breaking of affectional bonds*. London: Tavistock.
- Bowlby, J. (1980). *Attachment and loss: Vol. 3. Loss, sadness, and depression*. New York: Basic.
- Bowlby, J. (1988). *A secure base: Clinical applications of attachment theory*. London: Routledge.
- Brennan, K. A., Clark, C. L., & Shaver, P. R. (1998). Self-report measurement of adult attachment: An integrative overview. In A. Simpson & W. S. Rholes (Eds.), *Attachment theory and close relationships* (pp. 46–76). New York: Guilford Press.
- Brennan, K. A., & Morris, K. A. (1997). Attachment styles, self-esteem, and patterns of seeking feedback from romantic partners. *Personality and Social Psychology Bulletin*, **23**, 23–31.
- Brennan, K. A., & Shaver, P. R. (1998). Attachment styles and personality disorders: Their connections to each other and to parental divorce, parental death, and perceptions of parental caregiving. *Journal of Personality*, **66**, 835–878.
- Buss, D. M., Larsen, R. J., Westen, D., & Semmelroth, J. (1992). Sex differences in jealousy: Evolution, physiology and psychology. *Psychological Science*, **3**, 251–255.
- Carnelley, K. W., Pietromanco, P. R., & Jaffe, K. (1994). Depression, working models of others and relationship functioning. *Journal of Personality and Social Psychology*, **66**, 127–140.
- Cassidy, J. (1988). Child-mother attachment and the self in six-year-olds. *Child Development*, **59**, 121–134.
- Cassidy, J. (1990). Theoretical and methodological considerations in the study of attachment and the self in young children. In M. Greenberg, D. Cicchetti, & E. M. Cummings (Eds.), *Attachment in preschool years: Theory, research and interventions* (pp. 87–120). Chicago: University of Chicago Press.
- Cassidy, J., & Berlin, L. J. (1994). The insecure/ambivalent pattern of attachment: Theory and research. *Child Development*, **65**, 971–991.
- Cassidy, J., & Kobak, R. R. (1988). Avoidance and its relationship with other defensive processes. In J. Belsky & T. Nezworski (Eds.), *Clinical implications of attachment* (pp. 300–323). Hillsdale, NJ: Erlbaum.
- Cole, D. A., & Maxwell, S. E. (2003). Testing mediational models with longitudinal data: Myths and tips in the use of structural equation modeling. *Journal of Abnormal Psychology*, **112**, 558–577.

- Colin, V. (1996). *Human attachment*. New York: McGraw-Hill.
- Collins, N. L., & Read, S. J. (1990). Adult attachment, working models, and relationship quality in dating couples. *Journal of Personality and Social Psychology*, **58**, 644–663.
- Dickinson, K. A., & Pincus, A. L. (2003). Interpersonal analysis of grandiose and vulnerable narcissism. *Journal of Personality Disorders*, **17**, 188–207.
- Dutton, D. G. (1995). Domestic assault of women: Psychological and criminal justice perspectives. *Canadian Journal of Criminology*, **37**, 567–574.
- Drigotas, S., & Barta, W. (2001). The cheating heart: Scientific explorations of infidelity. *Current Directions in Psychological Science*, **10**, 177–180.
- Feeney, J. A., & Noller, P. (1990). Attachment style as a predictor of adult romantic relationships. *Journal of Personality and Social Psychology*, **58**, 281–291.
- Feeney, J. A., & Ryan, S. M. (1994). Attachment style and affect regulation: Relationships with health behavior and family experiences of illness in a student sample. *Health Psychology*, **13**, 334–345.
- Feintuch, B. (1999). Adult attachment, narcissism, shame, and defensiveness. *Dissertation Abstracts International*, **59** (10-B), 5575.
- Foster, J. D., & Kernis, M. H. (2007). Linking adult attachment to self-esteem stability. *Self and Identity*, **6**, 64–73.
- Fraley, R. C., Waller, N. G., & Brennan, K. A. (2000). An item-response theory analysis of self-report measures of adult attachment. *Journal of Personality and Social Psychology*, **78**, 350–365.
- Gabbard, G. O. (1998). Transference and counter-transference in the treatment of narcissistic patients. In E. F. Ronningstam (Ed.), *Disorders of narcissism: Diagnostic, clinical, and empirical implications* (pp. 125–145). Washington, DC: American Psychiatric Association.
- Gleason, T. R., Jarudi, R. N., & Cheek, J. M. (2003). Imagination, personality, and imaginary companions. *Social Behavior and Personality*, **31**, 721–738.
- Greenberg, M. T., DeKlyen, M., Speltz, M. L., & Endriga, M. C. (1997). The role of attachment processes in externalizing psychopathology in young children. In L. Atkinson & K. J. Zucker (Eds.), *Attachment and psychopathology* (pp. 196–222). New York: Guilford Press.
- Griffin, D. W., & Bartholomew, K. (1994a). The metaphysics of measurement: The case of adult attachment. In I. K. Bartholomew & D. Perlman (Eds.), *Advances in personal relationships: Attachment processes in adulthood* (Vol. 5, pp. 17–52). London: Jessica Kingsley.
- Griffin, D. W., & Bartholomew, K. (1994b). Model of the self and other: Fundamental dimensions underlying measures of adult attachment. *Journal of Personality and Social Psychology*, **67**, 430–445.
- Guerrero, L. K., & Burgoon, J. K. (1996). Attachment styles and reactions to nonverbal involvement change in romantic dyads: Patterns of reciprocity and compensation. *Human Communication Research*, **22**, 335–370.
- Harris, C. R. (2003). A review of sex differences in sexual jealousy, including self-report data, psychophysiological responses, interpersonal violence, and morbid jealousy. *Personality and Social Psychology Review*, **7**, 102–128.

- Harris, C. R. (2005). Male and female jealousy, still more similar than different: Reply to Sagarin (2005). *Personality and Social Psychology Review*, *7*, 76–86.
- Hazan, C., & Shaver, P. R. (1987). Romantic love conceptualized as an attachment process. *Journal of Personality and Social Psychology*, *52*, 511–524.
- Hazan, C., & Shaver, P. R. (1994). Attachment as an organizational framework for research on close relationships. *Psychological Inquiry*, *5*, 1–22.
- Hendin, H. M., & Cheek, J. M. (1997). Assessing Hypersensitive Narcissism: A Re-examination of Murray's Narcissism Scale. *Journal of Research in Personality*, *31*, 588–599.
- Hoyle, R. H., & Smith, G. T. (1994). Formulating clinical research hypotheses as structural equation models: A conceptual overview. *Journal of Consulting and Clinical Psychology*, *62*, 429–440.
- Hu, L. T., & Bentler, P. M. (1998). Fit indices in covariance structure modeling: Sensitivity and underparamaterized model misspecification. *Psychological Methods*, *3*, 424–453.
- Hu, L. T., & Bentler, P. M. (1999). Cutoff criteria for fit indexes in covariance structure analysis: Conventional criteria versus new alternatives. *Structural Equation Modeling*, *6*, 1–55.
- Isabella, R. A., & Belsky, J. (1991). Interactional synchrony and the origins of infant-mother attachment: A replication study. *Child Development*, *62*, 373–384.
- Kelloway, E. K. (1998). *Using lisrel for structural equation modeling: A researcher's guide*. Newbury Park, CA: Sage.
- Kernberg, O. F. (1985). Regression in organizational leadership. In A. D. Colman & M. H. Geller (Eds.), *Group relations reader 2* (pp. 89–107). Springfield, VA: A. K. Rice Institute.
- Kobak, R. R., & Sceery, A. (1988). Attachment in late adolescence: Working models, affect regulation, and representations of self and others. *Child Development*, *59*, 135–146.
- Kohut, H., & Wolf, E. S. (1978). The disorders of the self and their treatment: An outline. *International Journal of Psychoanalysis*, *59*, 413–425.
- Landry, S. H., Smith, K. E., Swank, P. R., & Miller-Loncar, C. L. (2000). Early maternal and child influences on children's later independent cognitive and social functioning. *Child Development*, *71*, 358–375.
- Leary, M. R., & Baumeister, R. F. (2000). The nature and function of self-esteem: Sociometer theory. In M. P. Zanna (Ed.), *Advances in experimental social psychology* (Vol. 32, pp. 1–62). New York: Academic Press.
- Lehrer, P. M., & Woolfolk, R. L. (1982). Self-report assessment of anxiety: Somatic, cognitive, and behavioral modalities. *Behavioral Assessment*, *4*, 167–177.
- Lopez, G., Mitchell, P., & Gormley, B. (2002). Adult attachment orientations and college student distress: Test of a mediational model. *Journal of Counseling Psychology*, *49*, 460–467.
- Lyons-Ruth, K., Alpern, L., & Repacholi, B. (1993). Disorganized infant attachment classification and maternal psychosocial problems as predictors of hostile-aggressive behavior in the preschool classroom. *Child Development*, *64*, 572–585.
- MacKinnon, D. P., Lockwood, C. M., Hoffman, J. M., West, S. G., & Sheets, V. (2002). A comparison of methods to test mediation and other intervening variable effects. *Psychological Methods*, *7*, 83–104.

- Mallinckrodt, B., Abraham, W. T., Wei, M., & Russell, D. W. (2006). Advances in testing the statistical significance of mediation effects. *Journal of Counseling Psychology, 53*, 371–378.
- Meier, M. J. (2004). Exploring narcissism in a group of male batterers. *Dissertation Abstracts International, 64* (10-A), 3846.
- Mickelson, K. D., Kessler, R. C., & Shaver, P. R. (1997). Adult attachment in a nationally representative sample. *Journal of Personality and Social Psychology, 73*, 1092–1106.
- Mikulincer, M. (1995). Attachment style and the mental representation of the self. *Journal of Personality and Social Psychology, 69*, 1203–1215.
- Mikulincer, M. (1998a). Adult attachment style and affect regulation: Strategic variations in self-appraisals. *Journal of Personality and Social Psychology, 75*, 420–435.
- Mikulincer, M. (1998b). Adult attachment style and individual differences in functional versus dysfunctional experiences of anger. *Journal of Personality and Social Psychology, 74*, 513–524.
- Mikulincer, M., & Florian, V. (1995). Appraisal and coping with a real-life stressful situation: The contribution of attachment styles. *Personality and Social Psychology Bulletin, 21*, 408–416.
- Mikulincer, M., Florian, V., & Weller, A. (1993). Attachment styles, coping strategies, and posttraumatic psychological distress: The impact of the Gulf War in Israel. *Journal of Personality and Social Psychology, 64*, 817–826.
- Mikulincer, M., Kedem, P., & Paz, D. (1990). Anxiety and categorization—I: The structure and boundaries of mental categories. *Personality and Individual Differences, 11*, 805–814.
- Mikulincer, M., Orbach, I., & Iavnieli, D. (1998). Adult attachment style and affect regulation: Strategic variations in subjective self-other similarity. *Journal of Personality and Social Psychology, 75*, 436–448.
- Mikulincer, M., Paz, D., & Kedem, P. (1990). Anxiety and categorization—2. The structure and boundaries of mental categories. *Personality and Individual Differences, 11*, 815–821.
- Mikulincer, M., & Shaver, P. R. (2003). The attachment behavioral system in adulthood: Activation, psychodynamic, and interpersonal processes. In M. P. Zanna (Ed.), *Advances in experimental social psychology* (Vol. 35, pp. 53–152). San Diego, CA: Academic Press.
- Mikulincer, M., & Shaver, P. R. (2007). *Attachment in adulthood: Structure, dynamics, and change*. New York: Guilford Press.
- Mikulincer, M., Shaver, P. R., & Pereg, D. (2003). Attachment theory and affect regulation: The dynamics, development, and cognitive consequences of attachment-related strategies. *Motivation and Emotion, 27*, 77–102.
- Morf, C., & Rhodewalt, F. (2001). Expanding the dynamic self-regulatory processing model of narcissism: Research directions for the future. *Psychological Inquiry, 12*, 243–251.
- Murphy, B., & Bates, G. W. (1997). Adult attachment style and vulnerability to depression. *Personality and Individual Differences, 22*, 835–844.
- Offer, D., Ostrov, E., Howard, K. J., & Dolan, S. (1992). *Offer self-image questionnaire, revised*. Los Angeles: Western Psychological Services.

- Otway, L. J., & Vignoles, V. L. (2006). Narcissism and childhood recollections: A quantitative test of psychoanalytic predictions. *Personality and Social Psychology Bulletin*, *32*, 104–116.
- Park, L. E., Crocker, J., & Mickelson, K. D. (2004). Attachment styles and contingencies of self-worth. *Personality and Social Psychology Bulletin*, *30*, 1243–1254.
- Pistole, M. C. (1995). College students' ended love relationships: Attachment style and emotion. *Journal of College Student Development*, *36*, 53–60.
- Priel, B., & Shamai, D. (1995). Attachment style and perceived social support: Effect on affect regulation. *Personality and Individual Differences*, *19*, 235–241.
- Roberts, J. E., Gotlib, I. H., & Kassel, J. D. (1996). Adult attachment security and symptoms of depression: The mediating roles of dysfunctional attitudes and low self-esteem. *Journal of Personality and Social Psychology*, *70*, 310–320.
- Robins, R. W., Hendin, H. M., & Trzesniewski, K. H. (2001). Measuring global self-esteem: Construct validation of a single-item measure and the Rosenberg self-esteem scale. *Personality and Social Psychology Bulletin*, *27*, 151–161.
- Rose, P. (2002). The happy and unhappy faces of narcissism. *Personality and Individual Differences*, *33*, 379–392.
- Shaver, P. R., Schachner, D. A., & Mikulincer, M. (2005). Attachment style, excessive reassurance seeking, relationship processes, and depression. *Personality and Social Psychology Bulletin*, *31*, 343–359.
- Shrout, P. E., & Bolger, N. (2002). Mediation in experimental and nonexperimental studies: New procedures and recommendations. *Psychological Methods*, *7*, 422–445.
- Shrout, P. E., & Fleiss, J. L. (1979). Intraclass correlations: Uses in assessing rater reliability. *Psychological Bulletin*, *86*, 420–428.
- Simpson, J. A. (1990). The influence of attachment styles on romantic relationships. *Journal of Personality and Social Psychology*, *59*, 971–980.
- Smolewska, K., & Dion, K. L. (2005). Narcissism and adult attachment: A multivariate approach. *Self and Identity*, *4*, 59–68.
- Sobel, M. E. (1982). Asymptotic intervals for indirect effects in structural equations models. In S. Leinhardt (Ed.), *Sociological methodology 1982* (pp. 290–312). San Francisco: Jossey-Bass.
- Spencer, S. J., Zanna, M. P., & Fong, G. T. (2005). Establishing a causal chain: Why experiments are often more effective than mediational analyses in examining psychological processes. *Journal of Personality and Social Psychology*, *89*, 845–851.
- Spielberger, C. D., Jacobs, G. H., Russell, S. F., & Crane, R. S. (1983). Assessment of anger: The state-trait anger-scale. In J. N. Butcher & C. D. Spielberger (Eds.), *Advances in personality assessment* (Vol. 2, pp. 159–187). Hillsdale, NJ: Erlbaum.
- Steiger, J. H. (1980). Test for comparing elements of a correlation matrix. *Psychological Bulletin*, *87*, 245–251.
- Stuart, S., & Noyes, R., Jr. (1999). Attachment and interpersonal communication in somatization. *Psychosomatics*, *40*, 34–43.

- Tracy, J. L., & Robins, R. W. (2004). Putting the self into self-conscious emotions: A theoretical model. *Psychological Inquiry*, **15**, 103–125.
- Wei, M., Mallinckrodt, B., Russell, D. W., & Abraham, W. T. (2004). Maladaptive perfectionism as mediator and moderator between attachment and negative mood. *Journal of Counseling Psychology*, **51**, 201–212.
- West, M., & Sheldon, A. E. (1988). Classification of pathological attachment patterns in adults. *Journal of Personality Disorders*, **2**, 153–159.
- Wink, P. (1991). Two faces of narcissism. *Journal of Personality and Social Psychology*, **61**, 590–597.