

General Disclaimer

One or more of the Following Statements may affect this Document

- This document has been reproduced from the best copy furnished by the organizational source. It is being released in the interest of making available as much information as possible.
- This document may contain data, which exceeds the sheet parameters. It was furnished in this condition by the organizational source and is the best copy available.
- This document may contain tone-on-tone or color graphs, charts and/or pictures, which have been reproduced in black and white.
- This document is paginated as submitted by the original source.
- Portions of this document are not fully legible due to the historical nature of some of the material. However, it is the best reproduction available from the original submission.

Potential End-to-End Imaging Information Rate Advantages of Various Alternative Communication Systems

(NASA-CR-157263) POTENTIAL END-TO-END
IMAGING INFORMATION RATE ADVANTAGES OF
VARIOUS ALTERNATIVE COMMUNICATION SYSTEMS
(Jet Propulsion Lab.) 26 p HC A03/MF A01

N78-27308

Unclas
CSSL 17B G3/32 25141



National Aeronautics and
Space Administration

Jet Propulsion Laboratory
California Institute of Technology
Pasadena, California

TECHNICAL REPORT STANDARD TITLE PAGE

1. Report No. JPL Pub. 78-52	2. Government Accession No.	3. Recipient's Catalog No.	
4. Title and Subtitle Potential End-to-End Imaging Information Rate Advantages of Various Alternative Communication Systems		5. Report Date June 15, 1978	
		6. Performing Organization Code	
7. Author(s) Robert F. Rice		8. Performing Organization Report No.	
9. Performing Organization Name and Address JET PROPULSION LABORATORY California Institute of Technology 4800 Oak Grove Drive Pasadena, California 91103		10. Work Unit No.	
		11. Contract or Grant No. NAS 7-100	
		13. Type of Report and Period Covered JPL Publication	
12. Sponsoring Agency Name and Address NATIONAL AERONAUTICS AND SPACE ADMINISTRATION Washington, D.C. 20546		14. Sponsoring Agency Code	
15. Supplementary Notes			
16. Abstract <p>This paper addresses a specific communication system problem which has characterized planetary exploration but which also appears in other applications. The results provide a new means of comparing the efficiency of various communication systems which are required to transmit both imaging and a typically error sensitive, class of data called general science/engineering (gse) over a Gaussian channel. The approach jointly treats the imaging and gse transmission problems, allowing comparisons of systems which include various channel coding and data compression alternatives. Actual system comparisons include an "Advanced Imaging Communication System" (AICS) which exhibits the rather significant potential advantages of sophisticated data compression coupled with powerful yet practical channel coding.</p>			
17. Key Words (Selected by Author(s)) Spacecraft Communications, Command and Tracking Communications - Systems Analysis Electronics and Electrical Engineering Lunar and Planetary Exploration		18. Distribution Statement Unclassified - Unlimited	
19. Security Classif. (of this report) Unclassified	20. Security Classif. (of this page) Unclassified	21. No. of Pages 26	22. Price

Potential End-to-End Imaging Information Rate Advantages of Various Alternative Communication Systems

Robert F. Rice

June 15, 1978

National Aeronautics and
Space Administration

Jet Propulsion Laboratory
California Institute of Technology
Pasadena, California

PREFACE

The work described in this report was performed by the Information Systems Division of the Jet Propulsion Laboratory.

CONTENTS

I.	INTRODUCTION -----	1
II.	SYSTEM COMPARISONS -----	4
	APPENDIX -----	18
	REFERENCES -----	19

Figures

1	Method of System Comparisons -----	4
2	System 1, Uncoded Channel -----	5
3	System 2 (Uncoded/Golay) vs. Uncoded Baseline -----	5
4	System 3 (Conv/Viterbi) vs. Uncoded Baseline -----	7
5	System 4 (Conv/Viterbi-Golay) vs. Uncoded Baseline -----	7
6	System 5 (AICS) vs. Uncoded Baseline -----	8
7	System 1 Baseline: Uncoded -----	14
8	System 2 Baseline: Uncoded/Golay -----	15
9	System 3 Baseline: Conv/Viterbi -----	16
10	System 4 Baseline: Conv/Viterbi-Golay -----	17

Tables

1	Equations for Computing Imaging Rate Advantages -----	10
2	Tabulation of the A_{ij} -----	11
3	Imaging Rate Advantages, Example 1 -----	12

PRECEDING PAGE BLANK NOT FILMED

ABSTRACT

This paper addresses a specific communication system problem which has characterized planetary exploration but which also appears in other applications. The results provide a new means of comparing the efficiency of various communication systems which are required to transmit both imaging and a typically error sensitive, class of data called general science/engineering (gse) over a Gaussian channel. The approach jointly treats the imaging and gse transmission problems, allowing comparisons of systems which include various channel coding and data compression alternatives. Actual system comparisons include an "Advanced Imaging Communication System" (AICS) which exhibits the rather significant potential advantages of sophisticated data compression coupled with powerful yet practical channel coding.

**ORIGINAL PAGE IS
OF POOR QUALITY**

POTENTIAL END-TO-END IMAGING INFORMATION RATE
ADVANTAGES OF VARIOUS ALTERNATIVE
COMMUNICATION SYSTEMS

I. INTRODUCTION

This paper addresses a specific communication system problem which has characterized planetary exploration but which also appears in other applications. We provide a new means of comparing the efficiency of various communication systems which are required to transmit both imaging and a, typically error sensitive, class of data called general science/engineering (gse) over a Gaussian channel (the usual space channel, no bandwidth limitations). This approach jointly treats the imaging and gse transmission problems and allows comparisons of systems which include various channel coding and data compression alternatives. Using this technique, specific comparisons of five alternative communication systems are provided, graphically displaying the sometimes huge performance differences that can exist between systems. For example, under certain conditions, the most sophisticated system (AICS, Ref. 1) would offer more than two orders of magnitude increase in imaging information rate compared to a single channel uncoded, uncompressed system while maintaining the same gse data rate in both systems (for the same antenna and transmitter power). The selected five systems probably span the full range of potential performance available today for communicating imaging and gse over the classic space channel. The relative performance of other systems not treated here can be obtained by simple deviations using the same techniques or in many cases simply by parameter substitution.

The Error Rate Disparity

Clearly, a communication system which must transmit more than one form of data must satisfy the minimum transmission error rate requirements

of all the data. Performance comparisons of various systems to accomplish this task must account for these constraints. This is precisely the situation considered here. Generally speaking, gse data can be classified as strictly error sensitive data although there may be slight differences in the error vulnerability of various types. Imaging data, on the other hand, may or may not be error sensitive depending on the method of image representation. The effect of transmission errors on uncompressed or spatially edited imaging tends to be significantly less than compressed imaging (or gse) for many techniques, particularly adaptive algorithms. However, certain image transform techniques have roughly an equal susceptibility to errors as uncompressed imaging. In either case a measure of system performance must account for the fact that the error requirements of all data must be simultaneously satisfied.

Systems Considered, Method of Comparison

The systems selected for comparison here represent an evolution of communication systems developed for planetary missions. The first four systems represent steps in that evolution (not chronological) based on the assumption that imaging data would be uncompressed (except for spatial editing) and gse data would be either nonexistent or at least always a small percentage of the total information rate. In that sense a comparison of systems 1-4 demonstrates distinct step-by-step improvements in efficiency. Part of the motivation of this paper is to display the relative efficiencies of these systems to transmit both uncompressed imaging and gse data.

Certainly there are variations to systems 1-4 and modifications which include various compression algorithms. It is a straightforward matter to present comparisons of such systems by use of the approaches developed here. However, we elect to demonstrate the potential advantages of data compression

by providing comparisons with system 5. System 5, called an "Advanced Imaging Communication System" (AICS) in Ref. 1, is the result of an end-to-end system design aimed at transmitting all forms of data efficiently and includes advanced channel coding and adaptive data compression techniques. Comparisons with system 5 should indicate roughly the maximum gains that are presently available from data compression.

Method of comparison. Each of the first four systems will be separately viewed as "Baseline systems." It is assumed in all cases that the channel parameters of each system are selected so that the minimum error rate requirements for all data are simultaneously satisfied. The gse transmission rate will be fixed in all systems as a fraction of the total information rate in the selected baseline. Then, the imaging information rate available in the baseline will be compared with that available in each other system. This is illustrated in Fig 1. An improvement in imaging information rate by β in any system means roughly the ability to transmit β times as many images with the equivalent information content as those transmitted in the baseline.*

*For example, an image compressed by 16:1 in system 5 might be equivalent to a 4:1 spatially edited image in the baseline. In this case the potential gains due to data compression alone would be $\gamma = 4$. The total end-to-end system advantage is the subject of subsequent sections.

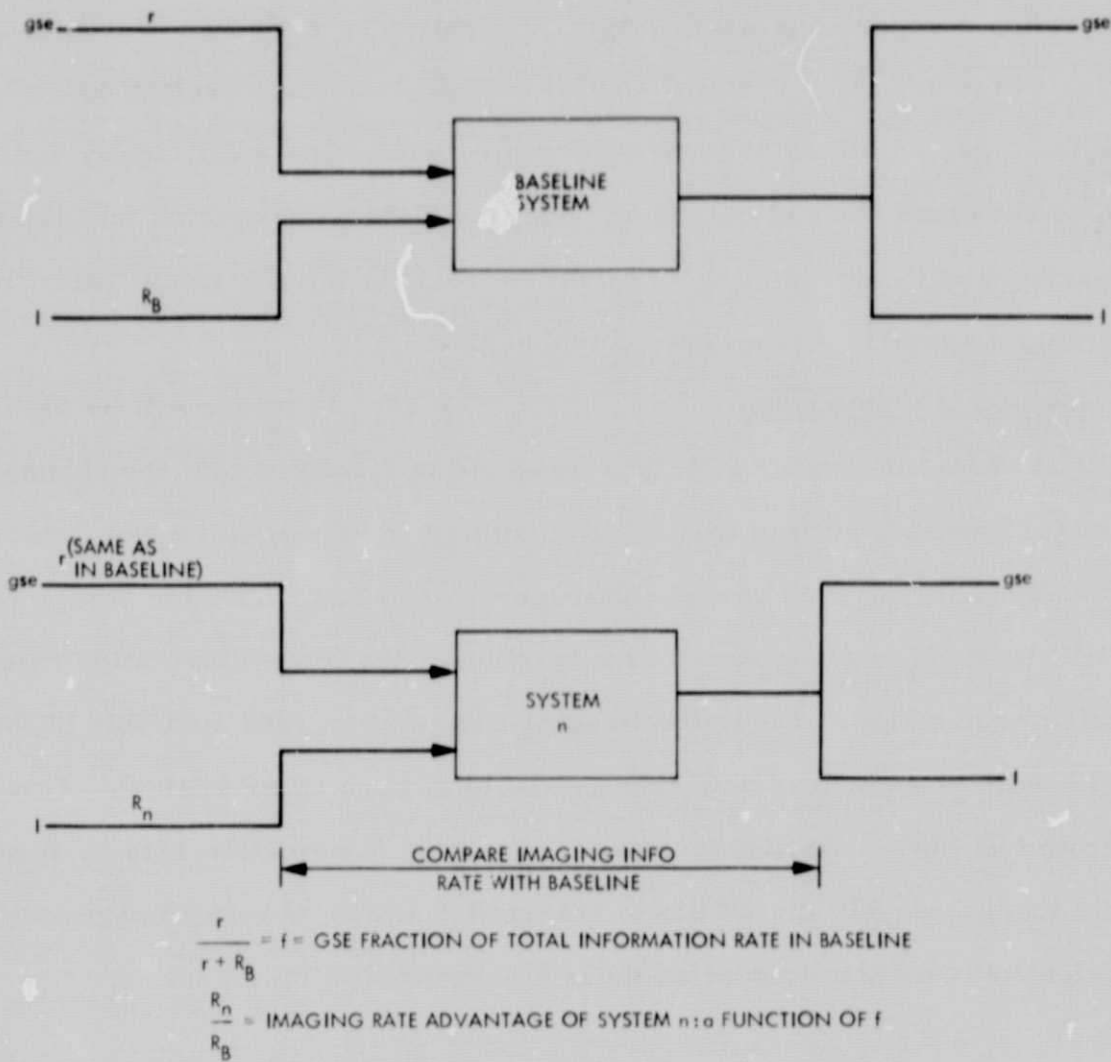

Fig. 1. Method of System Comparisons.

II. SYSTEM COMPARISONS*

Each of the systems considered will be introduced while treating system 1 as a baseline system (that is, the system to compare others to).

System Descriptions: System 1 as Baseline

System 1 is simply the familiar "uncoded channel" as diagrammed in Fig. 2.

*The necessary performance curves for various channel options can be found in Refs. 1-3. In all cases presented here we will assume PSK modulation and ideal coherent receiver operation.

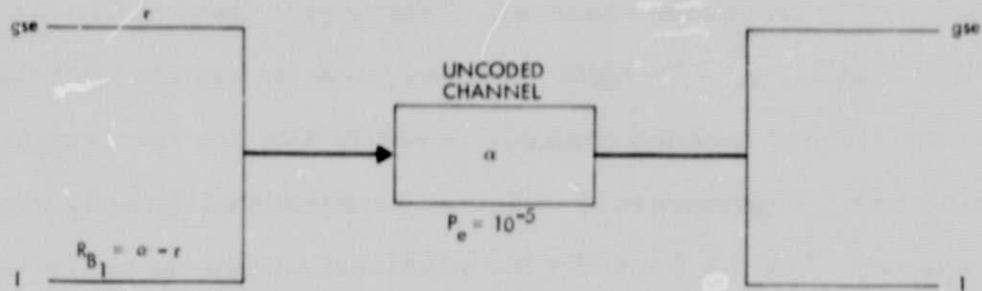

Fig. 2. System 1, Uncoded Channel.

Assuming this is the baseline system, gse data rate is fixed at an average rate of r bits/sec where $r/\alpha = f$ and α is the total available bit rate over the channel. Then $R_{B1} = \alpha - r$ is the imaging information rate available in the baseline system 1.

Assuming we fix antenna size, transmitter power, etc., α is determined solely by the allowed probability of error, P_e . The error sensitive gse data confines this choice to be low. For comparison purposes we will use $P_e = 10^{-5}$. The exact choice will have little impact on the end results and 10^{-5} seems to be an acceptable value. This operating point is obtained at a signal to noise ratio of roughly 9.7 db.

System 2: Uncoded/Golay. This system is diagrammed in Fig. 3.

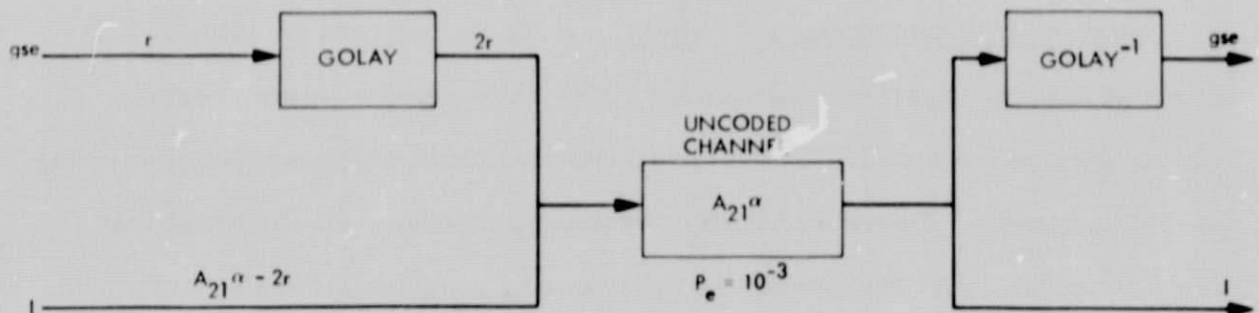

Fig. 3. System 2 (Uncoded/Golay) vs. Uncoded Baseline.

As shown in the figure, Golay block coding is applied to gse data before transmission over an uncoded channel. This is held fixed at the same rate as the baseline system, r . The Golay decoder corrects errors made in transmission over the "inner" uncoded channel. r parity bits are required for each r information bits. Uncompressed imaging is transmitted directly over the uncoded channel. See the Appendix for additional comments on the Golay.

Because of the additional protection of gse data, the uncoded channel in this system may be operated at higher error rates and hence higher transmission rates. Specifically, transmission rate on the uncoded channel portion may be increased provided that the net gse error rate is around 10^{-5} or less and uncompressed or spatially edited imaging is not substantially degraded. To meet this objective bit error rate requirements for imaging have historically been $P_e \leq 5 \times 10^{-3}$.

This gse constrained operating point for the inner uncoded channel occurs in the range of 5×10^{-3} to 10^{-3} . We will assume a $P_e = 10^{-3}$ in the graphical examples. From uncoded channel performance curves the $P_e = 10^{-3}$ operating point occurs at roughly 6.8 db. This satisfies the requirements for imaging noted above. Thus the uncoded channel in system 2 may be operated at 2.9 db above that in System 1 or at a rate of $A_{21} \alpha = 1.95\alpha$. Operating points substantially above this point would rapidly damage gse data. This leaves an imaging rate of $R_2 = A_{21} \alpha - 2r$ in system 2.

System 3: Convolutional/Viterbi. A block diagram of system 3 is shown in Fig. 4. System 3 looks much like the baseline system except that all data is first coded by a convolutional coder, and then decoded using Viterbi decoders. There are many variations that may fit different mission situations. For the purpose of presenting graphical results here we will assume the same principal code used on the Voyager missions to Jupiter and Saturn, a constraint $K=7, \mu=2$ code with 3 bits of receiver

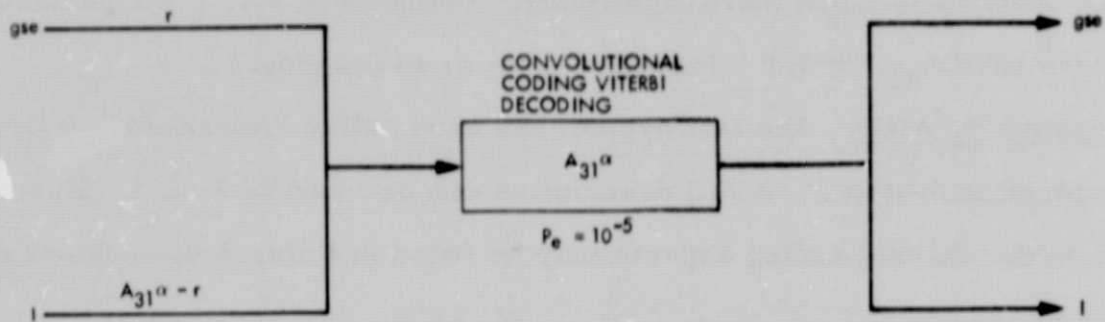

Fig. 4. System 3 (Conv/Viterbi) vs. Uncoded Baseline.

quantization. Graphs for other options can easily be obtained by modifying input parameters. From the $K = 7$, $\nu = 2$ performance curves under ideal receiver operating conditions, $A_{31} \approx 3.09$, when $P_e \approx 10^{-5}$.

System 4, Voyager. A block diagram of system 4 appears in Fig. 5.

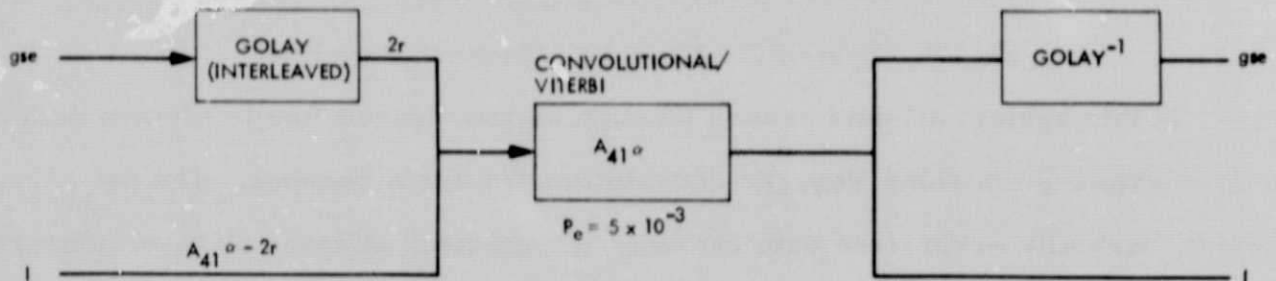

Fig. 5. System 4 (Conv/Viterbi-Golay) vs. Uncoded Baseline.

This system configuration is basically the Voyager communication system (also called the Jupiter/Saturn communication system in Refs. 1 and 2). It looks much like system 2, Uncoded/Golay, except that the inner channel is the more powerful convolutional/Viterbi.

We will assume that the inner channel can be operated at up to a $P_e = 5 \times 10^{-3}$ while maintaining an adequately low P_e on gse data. Again it is unimportant to worry about precise operating points. The main differences

between systems is much more significant. Using the $K = 7, \nu = 2$ performance curves we have $A_{41}^{\alpha} \approx 5.5$ leaving $A_{41}^{\sigma} - 2r$ to imaging.*

System 5, AICS. The last system has been called "Advanced Imaging Communication System." A full description can be found in Ref. 1. Particular details on the channel coding aspects may be found in Refs. 2-4. A block diagram appears in Fig. 6.

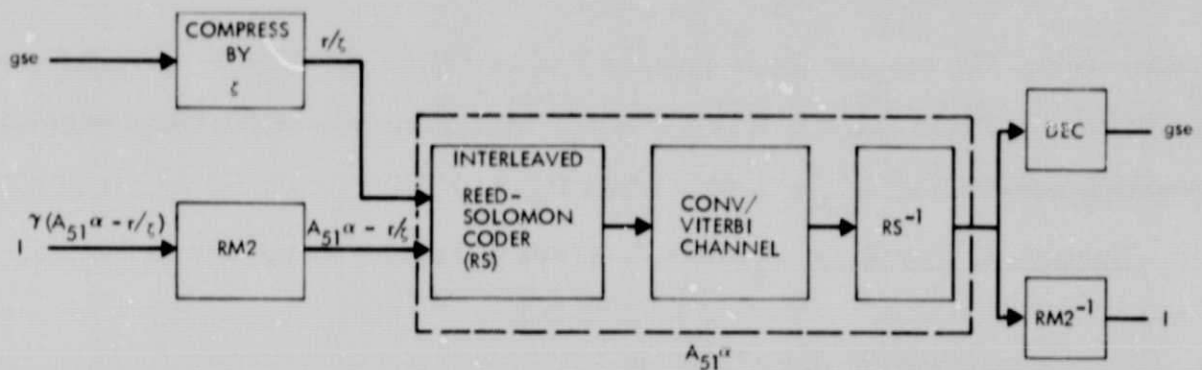

Fig. 6. System 5 (AICS) vs. Uncoded Baseline.

In this system all data passes through an interleaved Reed-Solomon coder before entering the same Voyager convolutional/Viterbi channel. The net result, virtually error-free data can be communicated at rates up to very nearly that at which the convolutional/Viterbi channel alone obtains a 5×10^{-3} error rate. That is, $A_{51} \approx A_{41}$ **

With this kind of channel, there is no problem with communicating error sensitive data. In Fig. 6, we have assumed that gse data is compressed by some factor ζ without any loss in true information. This appears quite feasible and in any event ζ should be a system parameter even if we set it equal to 1. In the graphical results the case of $\zeta = 1$ or 2 will be included.

* $A_{41} \approx 4.07$ for a "low overhead" $K = 9, \nu = 4/3$ code. Linkabit offers decoders for such a code.

** $A_{51} \approx 5.13$ for the $\nu = 2$ code, $A_{51} \approx 5.75$ for $\nu = 3$ and $A_{51} \approx 3.8$ for a low overhead $K = 9, \nu = 4/3$ code.

The imaging data compression assumed is called RM2^[1] and was basically developed for monochromatic images. It is an extremely adaptive algorithm which gives the user and mission designer extensive flexibility. Any compression factor can be selected for any image.

RM2 was evaluated for flyby missions by imaging scientists^[5] who concluded that it offered an information rate advantage in the range of 4-6 compared to the alternatives of no compression or spatial edit.* For other missions which could make full use of the adaptive character of RM2, the upper range might be more like 10:1. Then γ in Fig. 6 refers to the effective increase in the number of pictures of roughly the same quality that would be obtained using RM2 on monochromatic images compared to what is presently done, direct PCM or spatial edit.

If registered color bands were available, then higher compression factors (for the same fidelity) should be possible either with RM2 (and some small increase in operations) or more directly using the CCA algorithm [7]-[9] developed specifically for multispectral images.

Referring back to the diagram in Fig. 6 we see that $\gamma(A_{51}^\alpha - r/\xi)$ is the imaging information rate for AICS.

Derivation of Imaging Rate Advantages

For each system just described we wish to obtain a more useful form of the ratio R_n/R_B given in Fig. 1. This requires no more than basic algebra. We will illustrate the procedure here for AICS only. Equations for all systems, including different baseline choices are given in Table 1.

From Figs. 1 and 2 we have

$$f = r/\alpha \quad (1)$$

*Comparisons of RM2 with other monochromatic algorithms can be found in Ref. 6. Adaptive cosine curves were mislabeled as adaptive Fourier in that document.

Table 1. Equations for Computing Imaging Rate Advantages.

Assumed Baseline System	Imaging Rate Advantage Factor Above Baseline				
	System 1 Uncoded	System 2 Uncoded Golay	System 3 Conv/Viterbi	System 4 Conv/Viterbi-Golay	System 5 AICS
System 1 Uncoded	1	$\frac{A_{21} - 2f}{1-f}$	$\frac{A_{31} - f}{1-f}$	$\frac{A_{41} - 2f}{1-f}$	$\frac{\gamma(A_{51} - f/\zeta)}{1-f}$
System 2 Uncoded/Golay	$\frac{A_{12} - f(1-A_{12})}{1-f}$	1	$\frac{A_{32} - f(1-A_{32})}{1-f}$	$\frac{A_{42} - f(2-A_{42})}{1-f}$	$\frac{\gamma[A_{52} - f(1/\zeta - A_{52})]}{1-f}$
System 3 Conv/Viterbi	$\frac{A_{13} - f}{1-f}$	$\frac{A_{23} - 2f}{1-f}$	1	$\frac{A_{43} - 2f}{1-f}$	$\frac{\gamma(A_{53} - f/\zeta)}{1-f}$
System 4 Conv/Viterbi-Golay	$\frac{A_{14} - f(1-A_{14})}{1-f}$	$\frac{A_{24} - f(2-A_{24})}{1-f}$	$\frac{A_{34} - f(1-A_{34})}{1-f}$	1	$\frac{\gamma[A_{54} - f(1/\zeta - A_{54})]}{1-f}$

- gse data rate held fixed in all systems as fraction f of total information rate in Baseline System.
- $A_{ij} = 1/A_{ji}$ = Rate Advantage in operating imaging channel of system i over imaging channel of system j (see Figs. 2-6).

$$R_B = \sigma - r = r(1-f)/f \quad (2)$$

Then from Fig. 6

$$\begin{aligned} R_5 &= \gamma(A_{51} \sigma - r/\zeta) \\ &= \gamma(A_{51} \frac{r}{f} - r/\zeta) \\ &= \frac{\gamma(A_{51} - f/\zeta)}{1-f} R_B \end{aligned} \quad (3)$$

The same approach can be followed for other systems. Similarly, picking a new baseline is no more complicated. The only difference is to now let σ be the "imaging channel" rate for the selected baseline. Imaging channel refers to those channel elements over which imaging data passes, it does not exclude gse data.

Equations for Computing Imaging Rate Advantages

The necessary equations are shown in Table 1. Note that the rate factor

$A_{ij} = 1/A_{ji}$ now more generally refers to the increase in transmission rate of the imaging channel of system i over that of system j .*

A complete listing of the A_{ij} used here is given in Table 2.

Table 2. Tabulation of the A_{ij} .

System Number		Imaging Channel Rate Improvement Factor A_{ij}				
		j \longrightarrow				
		1	2	3	4	5
i \downarrow	1	1.0	0.51	0.32	0.18	0.19
	2	1.95	1.0	0.63	0.35	0.38
	3	3.09	1.58	1.0	0.56	0.60
	4	5.50	2.82	1.78	1.0	1.07
	5	5.13	2.63	1.66	0.93	1.0

Graphical Results

Plots of the equations in Table 1 are shown in Figs. 7-10 using f as a parameter. Additional assumptions and observations are given in the Appendix. Included is a separate graph of RS/Viterbi which is AICS with $\gamma = 1$, $\zeta = 1$.

Example 1. Suppose that the uncoded channel (system 1) was considered the baseline communication system. Upon sizing up the power, antenna, etc., it was concluded that 1 kilobit/sec was available at the required $P_e = 10^{-5}$. Science instruments required at least $r = 500$ b/sec to be reasonable, leaving 500 b/sec for imaging. Then

$$f = \frac{500}{1000} = 0.5, R_B = 500. \quad (4)$$

*Observe that the $f=0$ condition is really a discontinuity point for some of the systems because gse requirements would not constrain channel operating points. This fact is not included in Table 1 or subsequent graphs.

The graphs in Fig. 7 compare the relative amount of imaging information rate with the $R_B = 500$ in the baseline under the constraint that the gse data rate is the same (500 here) in all systems. From Fig. 7 with $f = .5$ we see the following imaging information rate advantages in Table 3.

Table 3. Imaging Rate Advantages, Example 1.

System	Approximate Factor, R_n/R_B	Imaging Information Rate bits/sec
Uncoded/Golay	1.9	950
Convolutional/Viterbi	4.5	2250
Conv/Viterbi-Golay	8.6	4300
RS/Viterbi	9.3	4650
AICS	37 to 93	18500 to 46500

Given AICS and 18500 bits/sec or more of imaging instead of 500 it is likely that the allocation to gse data would increase since it would constitute now less than 3% of the total.

Example 2. Now start with a more powerful baseline system, the Voyager communication system. Assume that the available data rate for imaging and gse (at acceptable error rates) is 5 KB/sec. This is similar to the situation which would be faced if X-band failed near Saturn during the actual Voyager mission. Let $f = .5$ again so that gse data rate is $r = 2500$ b/sec. Using Fig. 10 we see that if we assume no gse data compression, AICS offers an imaging rate advantage of between 7 and 18 (17500 and 45000 bits/sec respectively). If in addition we assume a not unreasonable additional 2:1 gse compression, the rate advantage factors increase to between 9 and 23 (22500 and 57500 bits/sec respectively).

Discussion

The graphical results illustrate the significant performance differences between several alternative systems for communicating imaging and gse over the classic Gaussian space channel with no bandwidth limitations. These results and the approach in obtaining them will hopefully be useful in addressing some of the possible tradeoffs for future space missions as well as other applications.

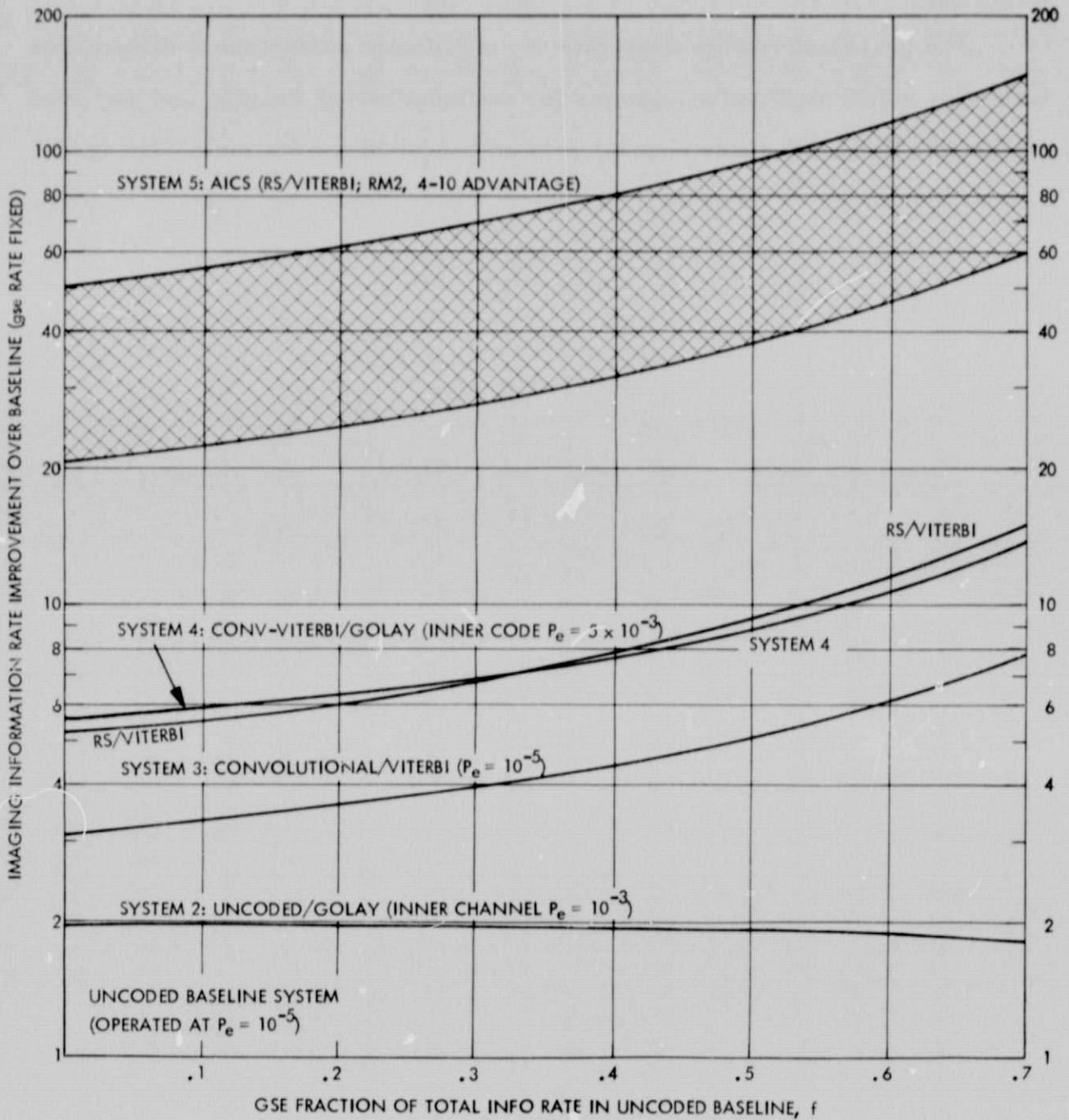

Fig. 7. System 1 Baseline: Uncoded.

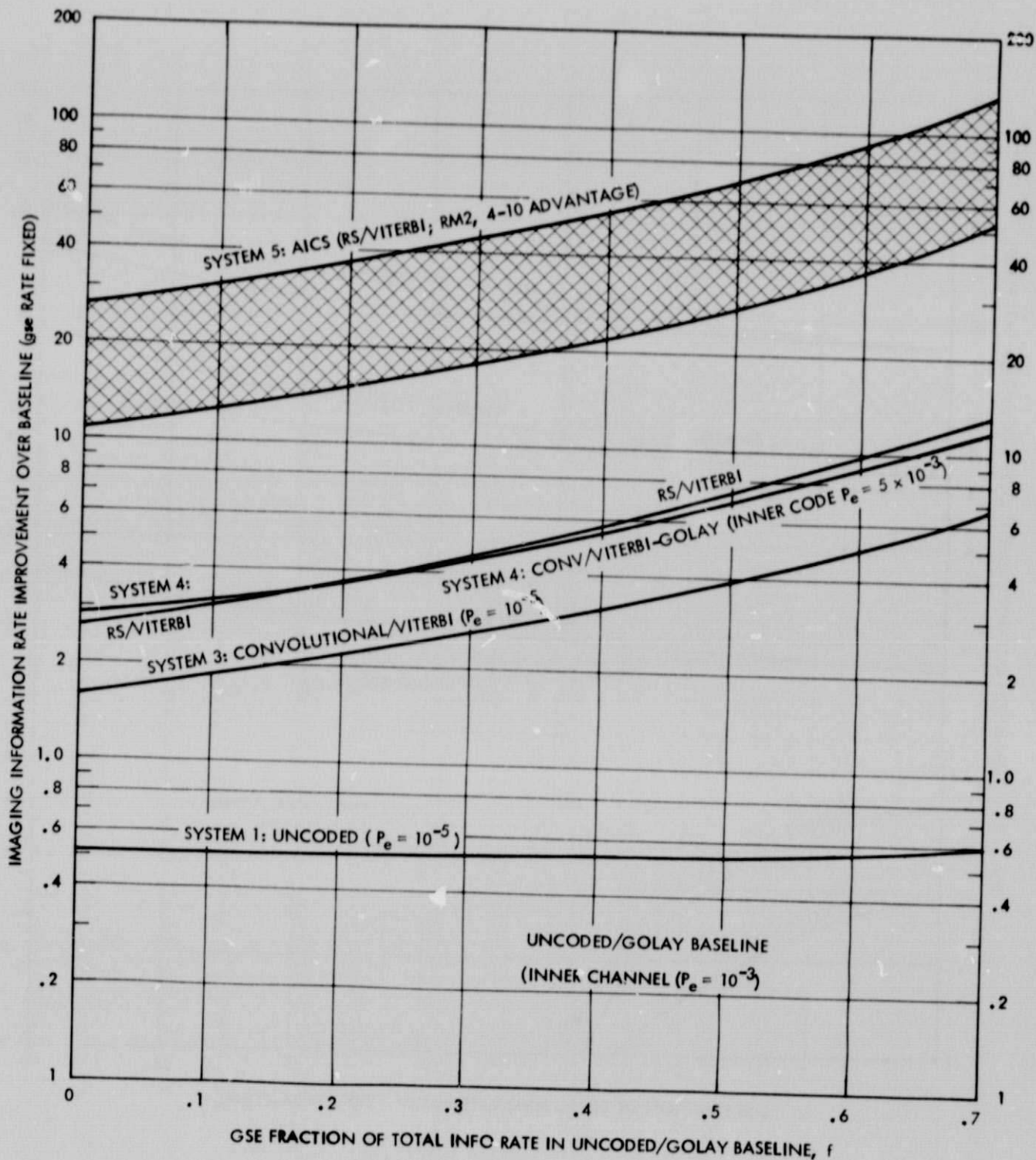

Fig. 8. System 2 Baseline: Uncode/golay.

ORIGINAL PAGE IS
OF POOR QUALITY

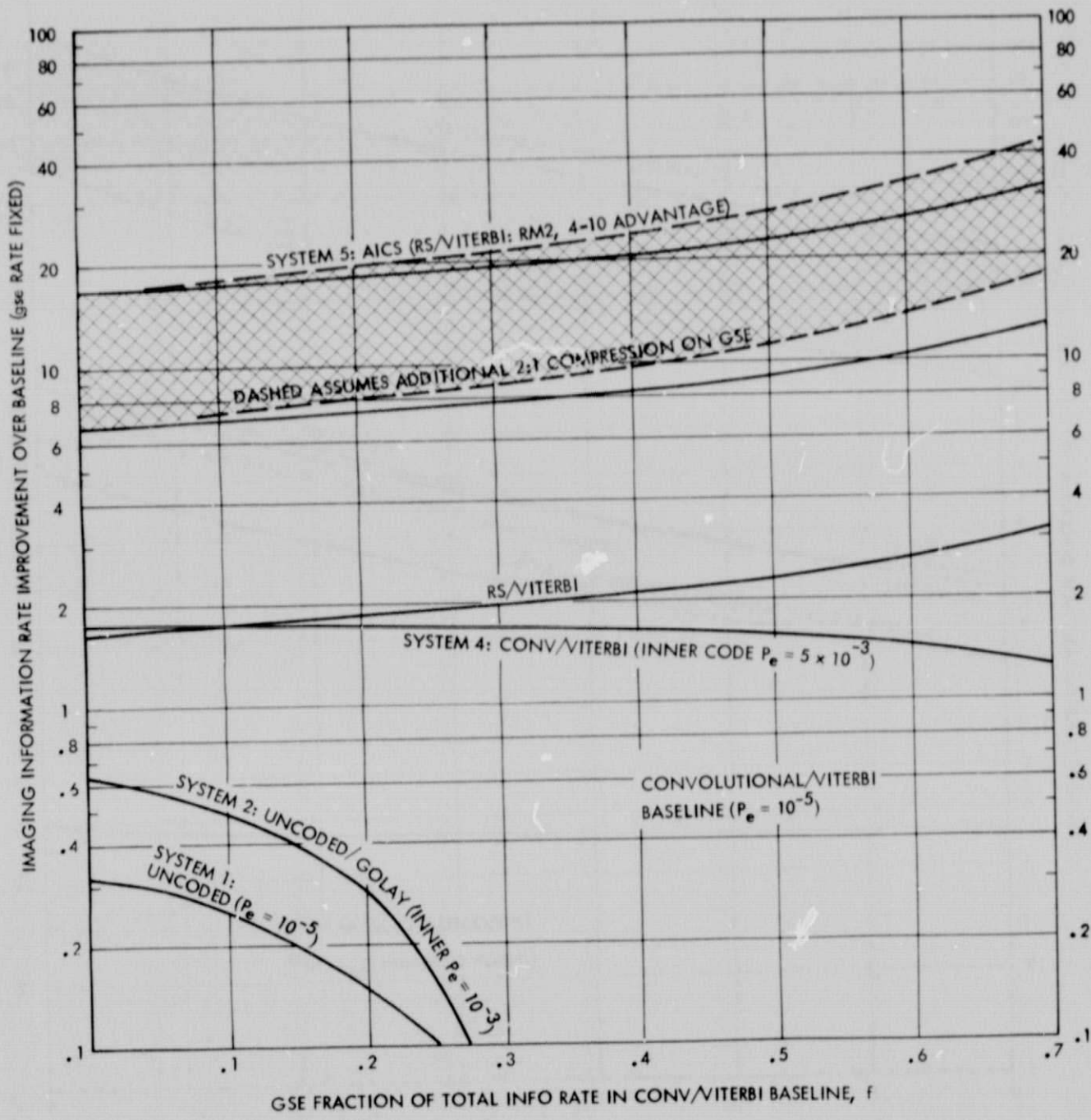

Fig. 9. System 3 Baseline: Conv/Viterbi.

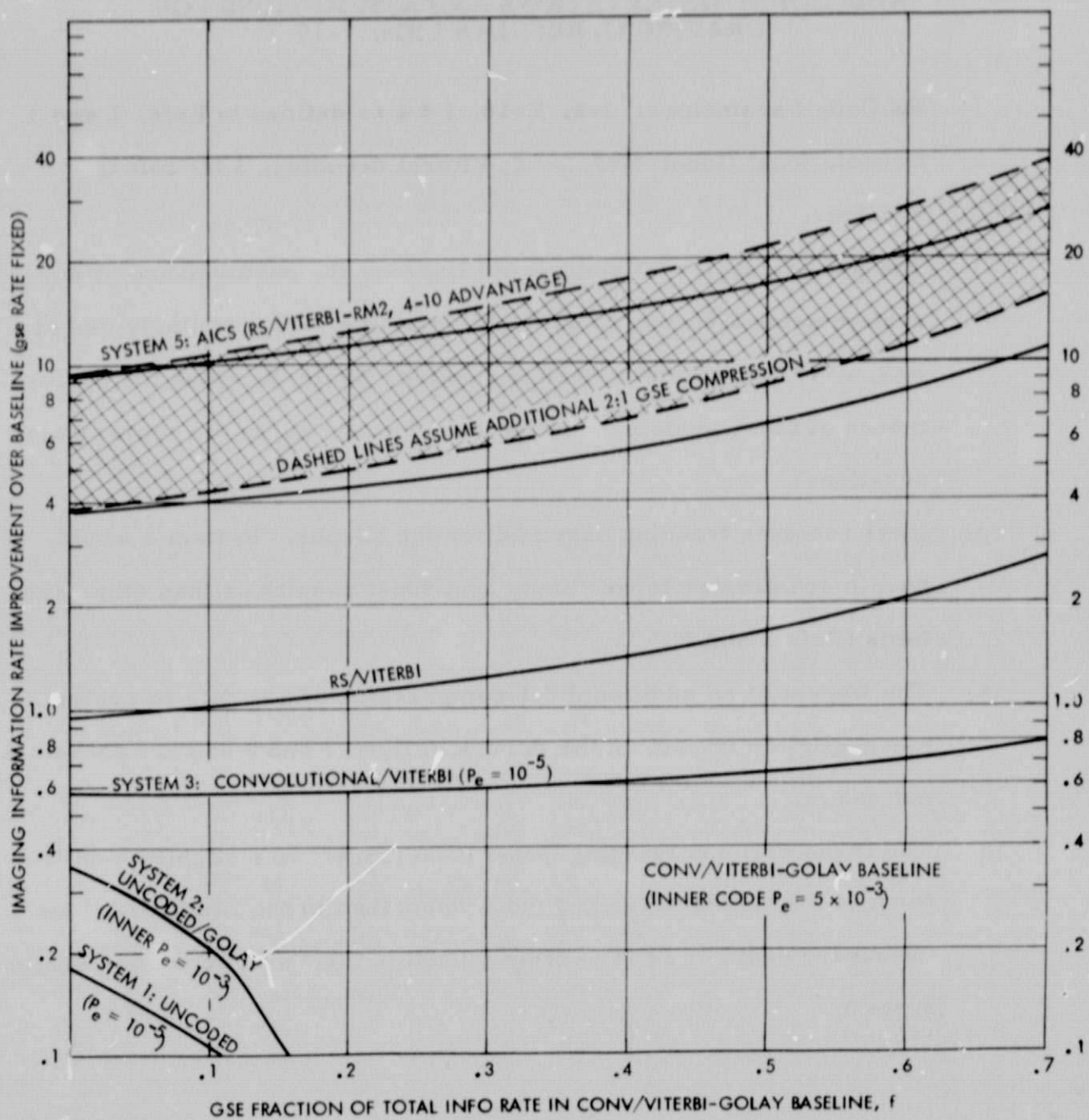

Fig. 10. System 4 Baseline: Conv/Viterbi-Golay.

APPENDIX

ADDITIONAL OBSERVATIONS AND ASSUMPTIONS FOR GRAPHICAL RESULTS FIGS. 7-10

- 1) RS Code Parameters: $J=8$, $E=16$, $I \geq 4$ as defined in Refs. 2 and 3.
- 2) Convolutional Code: $K=7$, $\nu = 2$; Viterbi decoding, 3 bit soft Q receiver.

The use of a $K=7$, $\nu = 3$ code would improve the performance of any system using a convolutional code, systems 3-5. Similarly use of a $K=9$, $\nu=4/3$ code and/or hard Q receiver would decrease the performance of these systems. (substitute the new A_{ij} in the appropriate equations).

- 3) Ideal receiver tracking assumed for the graphs. System 3 would have much greater losses under non-ideal conditions than other systems (Refs 2 and 3).
- 4) The impact of an additional 2:1 compression of gse data in system 5 has negligible impact on the curves in figs. 7 and 8 and are therefore not shown.
- 5) The three error correcting Golay code (24, 12) is a slightly modified form of the standard (23, 12) code described in the literature. An interleave depth of 24 is currently used in the Voyager communication system.

ORIGINAL PAGE IS
OF POOR QUALITY

REFERENCES

1. R. F. Rice, "An Advanced Imaging Communication System for Planetary Exploration," Vol. 66 SPIE Seminar Proceedings, Aug. 21-22, 1975, pp. 70-89.
2. R. F. Rice, "Channel Coding and Data Compression System Considerations for Efficient Communication of Planetary Imaging Data," Chapter 4, Technical Memorandum 33-695. Jet Propulsion Laboratory, Pasadena, CA, June 15, 1974.
3. J. P. Odenwalder, "Concatenated Reed-Solomon/Viterbi Channel Coding for Advanced Planetary Missions: Analysis, Simulations and Tests," submitted to Jet Propulsion Laboratory by Linkabit Corp., San Diego, CA, Final Rep., Contract 953866, Dec. 1, 1974.
4. J. P. Odenwalder, Contract 953866 Correspondence (see 3.).
5. J. Cutts and L. Lebofsky, "Evaluation of the RM2 Image Data Compression Technique for Outer Planet Missions with the Pioneer Spacecraft," submitted to Jet Propulsion Laboratory by Planetary Science Institute, Pasadena, CA, Final Rep., Contract 954152, Nov. 1975.
6. R. F. Rice, "RM2: rms Error Comparisons," Technical Memorandum 33-804. Jet Propulsion Laboratory, Pasadena, CA., Sept. 15, 1976.
7. E. E. Hilbert, "Joint Classification and Data Compression of Multi-Dimensional Information Sources - Applications to ERTS," Internat. Conf. on Commun., Vol. II, Session 27, pp. 6-11, June 1975.
8. E. E. Hilbert, "Joint Pattern Recognition/Data Compression Concept for ERTS Multi-Spectral Imaging," SPIE Seminar Proceedings, Vol. 66, pp. 122-137, Aug. 1975.
9. E. E. Hilbert, "A Joint Clustering/Data Compression Concept," Doctoral Dissertation, Dept. of Elec. Eng., Univ. of Southern Calif., Los Angeles, CA, May 1975.