



Aalborg Universitet

AALBORG UNIVERSITY
DENMARK

Energy and Frequency Hierarchical Management System Using Information Gap Decision Theory for Islanded Microgrids

Rezaei, Navid; Ahmadi, Abdollah; Khazali, Amirhossien; Guerrero, Josep M.

Published in:
IEEE Transactions on Industrial Electronics

DOI (link to publication from Publisher):
[10.1109/TIE.2018.2798616](https://doi.org/10.1109/TIE.2018.2798616)

Publication date:
2018

Document Version
Accepted author manuscript, peer reviewed version

[Link to publication from Aalborg University](#)

Citation for published version (APA):
Rezaei, N., Ahmadi, A., Khazali, A., & Guerrero, J. M. (2018). Energy and Frequency Hierarchical Management System Using Information Gap Decision Theory for Islanded Microgrids. *IEEE Transactions on Industrial Electronics*, 65(10), 7921-7932. <https://doi.org/10.1109/TIE.2018.2798616>

General rights

Copyright and moral rights for the publications made accessible in the public portal are retained by the authors and/or other copyright owners and it is a condition of accessing publications that users recognise and abide by the legal requirements associated with these rights.

- Users may download and print one copy of any publication from the public portal for the purpose of private study or research.
- You may not further distribute the material or use it for any profit-making activity or commercial gain
- You may freely distribute the URL identifying the publication in the public portal -

Take down policy

If you believe that this document breaches copyright please contact us at vbn@aub.aau.dk providing details, and we will remove access to the work immediately and investigate your claim.

Energy and Frequency Hierarchical Management System Using Information Gap Decision Theory for Islanded Microgrids

Navid Rezaei, Abdollah Ahmadi, *Student Member, IEEE*, Amirhossein Khazali, Josep M. Guerrero, *Fellow, IEEE*¹

Abstract—In this paper, a robust energy management system is proposed for islanded microgrids, which at the same time considers static modelling of system frequency. The aim of this paper is to manage frequency excursions produced from load and renewable generation fluctuations. In microgrids, the use of inertia-less and small-scale energy resources risks the frequency stability. In order to overcome this problem, first, the frequency-dependent behavior of the distributed energy resources is formulated precisely within the centralized hierarchical energy and reserve management context of a microgrid. Then, in order to handling microgrid uncertainties in a robust way, information gap decision theory (IGDT) technique is proposed. Furthermore, to address a robust hierarchical energy and frequency reserve management architecture, the problem is transmitted into a single level mixed-integer linear programming (MILP) model and solved appropriately over a 24-h scheduling time horizon. Numerical simulation results obtained on a typical islanded smart microgrid are presented including demand response mechanism. The IGDT can help microgrid central controller (MGCC) to make operational decisions in front of major uncertainties. The obtained results verify that through the proposed IGDT-based energy management system, the MGCC can effectively stabilize the microgrid frequency along with its economic targets while considering severe uncertainties.

Index Terms—Microgrid, Hierarchical energy management, Frequency control, Information gap decision theory, Uncertainty.

I. NOMENCLATURE

Acronyms

DRP	Demand Response Provider
DSO	Distribution System Operator
IGDT	Information Gap Decision Theory
IIDG	Inverter-Interfaced Distributed Generation
MCS	Monte-Carlo Simulation
MG	Microgrid
MGCC	Microgrid Central Controller

¹ Manuscript received July 22, 2017; revised September 27, 2017; accepted January 12, 2018.

(Corresponding Author: Navid Rezaei.)

N. Rezaei is with the Department of Electrical Engineering, University of Kurdistan, Sanandaj, Iran. P.C.: 66177-15177 (e-mail: n.rezaei@uok.ac.ir).

A. Ahmadi is with the Australian Energy Research Institute and the School of Electrical Engineering and Telecommunications, University of New South Wales, Sydney, NSW 2032, Australia. (e-mail: a.ahmadi@student.unsw.edu.au).

A. H. Khazali is with the Department of Electrical Engineering, Iran University of Science and Technology, Tehran, Iran (e-mail: amirhossein.khazali@gmail.com).

J. M. Guerrero is with the Department of Energy Technology, Aalborg University, 9220 Aalborg, Denmark (e-mail: joz@et.aau.dk).

MILP	Mixed Integer Linear Programming
MTC	Microgrid Total Cost
RES	Renewable Energy Source
WT/PV	Wind Turbine/Photovoltaic
Indices	
$d \in D$	index of DRPs
$g \in G$	index of IIDGs
$k \in K$	index of scheduled reserves could be <i>up</i> or <i>down</i>
$n \in N$	index of piece-wise blocks of DRPs offer package
$q \in Q$	index of hierarchical control level could be equal to <i>pri</i> (primary) and <i>sec</i> (secondary)
$t \in T$	index of energy management hours
$v \in V$	index of PVs
$w \in W$	index of WTs
Parameters	
m_{pg}	frequency droop parameter of IIDG g
Δf_{\max}^q	maximum allowable frequency excursion limit during control level q
a_g	fixed operation cost of IIDG g
b_g	first-order operation cost of IIDG g
$c_g^{\text{sup/dn}}$	start-up/shut-down cost of IIDG g
C_{gqk}^R	the cost of up/down reserve of IIDG g in control level q
C_w	the cost of operation of WT w
C_v	the cost of operation of PV v
P_g^{\max}	the upper level of active power generation of IIDG i
P_g^{\min}	the lower level of active power generation of IIDG i
$\text{ramp}_g^{\text{up}}$	ramp-up limit of IIDG i
$\text{ramp}_g^{\text{dn}}$	ramp-down limit of IIDG i
$\text{ramp}_g^{\text{sup}}$	start-up ramp of IIDG i
$\text{ramp}_g^{\text{sdn}}$	the shut-down ramp of IIDG i
$P_{L_t}^f$	forecasted load consumption at hour t
P_{wt}^f	forecasted active power output of WT w at hour t
P_{vt}^f	forecasted active power output of PV v at hour t
c_{dn}^{DR}	the cost of block n in DRP d offer package
Variables	
Δf_t^q	frequency deviation in control level q at hour t
ΔP_{gt}^q	active power deviation of IIDG g in control level q at hour t
ΔP_{dnt}^q	accepted load reduction of DRP d associate with block n in control level q at hour t
ΔP_{wt}^q	active power deviation of WT w in control level q at hour t

ΔP_{vt}^q	active power deviation of PV v in control level q at hour t
ΔP_{Lt}^q	power consumption deviation of the load in control level q at hour t
$\Delta P_{gt}^{ref,q}$	reference power deviation of IIDG g in control level q at hour t
P_{dnt}	accepted offered demand associate with block n in DRP d offer package
P_{gt}	the active power output of IIDG g at hour t
R_{gkt}^q	scheduled up/down reserve of IIDG g in control level q at hour t
u_{gt}	binary variable indicating commitment state of IIDG g at hour t
y_{gt}	binary variable indicating start-up state of IIDG g at hour t
z_{gt}	binary variable indicating the shut-down state of IIDG g at hour t
u_{gt}^q	binary variable indicating commitment state of IIDG g at hour t and control level q

II. INTRODUCTION

FREQUENCY excursions in power systems are a repeated phenomenon which must be managed properly using cost-effective ancillary services. Market-based hierarchical frequency regulation reserve scheduling has been proposed in [1], [2] to mitigate load fluctuations as a dominant origin of the frequency insecurity. However, the matter faces more challenges, when ever-increasing penetration of sporadic Renewable Energy Sources (RESs) and integrated static Inverter Interfaced Distributed Generations (IIDGs) are perceived. Besides, when eventual goals and small energy capacity of islanded smart Microgrids (MGs) is taken into account, the necessity to provide adequately frequency regulation services become an emergence [3]. Low inertia stack in a small region power delivery system, causes MGs treated as a more severe uncertain environment. Therefore, the significance of the MG frequency management is more critical comparing to the conventional power systems. Thus, MG Central Controller (MGCC) is required to implement an efficient energy management system. Indeed, the MGCC should adapt an energy management strategy through which not only operational targets of the MG are fulfilled [4], but also frequency security is provided reliably. In other words, uncontrolled frequency excursions straightly put the MG sustainable operation at risks.

Accordingly, islanded MGs need a robust frequency dependent hierarchical energy management system encompasses three levels [5]. The primary control level is concentrating on automatically voltage and frequency control of IIDGs [6]. To model the frequency security in the energy management problem of islanded MGs, the well-known grid-interactive grid-following droop based control method has been implemented [7]-[9]. Worth mentioning that the IIDGs are not substantially relying on the MG frequency, however, to provide a secure and flexible power sharing strategy and away from thermally overstressing risks, the reliable, automatic and wireless P - f droop control method is usually utilized [10], [11].

The MGCC is responsible for coordinated managing the primary and secondary regulation reserves from both IIDGs and demand response providers (DRPs). The MGCC should provide a synergy such that not only the operational costs are optimized but also the MG frequency lies within the pre-

defined secure ranges. In the primary level, droop controllers automatically release the scheduled primary reserves to mitigate active power imbalances. Hence, the MG frequency may deviate from its set-point value. The MGCC schedules the secondary reserves to optimistically restore the frequency to its nominal value. In the islanded mode, only the primary and secondary control levels are sufficient [8], [12]. The tertiary level is necessary for coordinated dispatching of various MGs which is executed by Distribution System Operator (DSO) [13].

In the literature, to manage the MG uncertainties, different methodologies have been employed. Scenario-based stochastic programming [14], probabilistic based approaches [15], robust optimization methodology [16], fuzzy-based strategies [17], have been proposed recently. None of the above mentioned researches considers the MG frequency security in the associated uncertainty handling models. In contrast, authors in [18], [19] focused mainly on frequency dependent behavior of the droop based local controllers and managed the associated real-time fuel costs. However, the supervisory performance of the MGCC has been paid attention pale, and the day-ahead reserve scheduling were not considered.

Authors in [20], [21] through proposing a precise model of the MG frequency security, optimizes energy and reserve resources regarding to the derived frequency constraints. Both the primary and secondary frequency control reserves have been carried out considering to the MG uncertainties using a two-level stochastic programming. Additionally, in [20], the MGCC benefits from the potential of DRPs in managing the frequency security more economically.

By detailed reviewing the literature and owing to less predictable and severe uncertain environment of the MGs, the lacuna of a robust hierarchical energy and frequency management system is still evident. To fill this gap out, in this paper, a robust non-probabilistic decision-making framework based on Information Gap Decision Theory (IGDT) is proposed. IGDT handles the sparse information and severe impoverish uncertainties in an exact and computationally efficient portfolio [22]. Recently, IGDT method has been applied in various power system studies such as bidding strategy [23], transmission expansion planning [24] and unit commitment [25], [26]. To the best of our knowledge, in this paper, it is the first time that the proficiency of IGDT is employed in the hierarchical energy and frequency management of the MGs to cope robustly with the considered load/RES uncertainties.

In this paper, the MG frequency dependent energy and reserve management problem has been formulated in an efficient Mixed Integer Linear Programming (MILP) framework. The proposed energy management is optimized robustly using the IGDT. The effectiveness of the IGDT-based approach is verified through comparison to the well-known stochastic based methodologies. Meanwhile, it is aimed to manage the flexible DRPs as well as the droop controlled IIDGs to provide an optimistic MG day-ahead energy and frequency scheduling portfolio.

Table I, summarizes the comparison between the proposed model and other existing methodologies. The approaches have

been compared based on uncertain parameters, uncertainty modeling technique and operational constraints included into the model.

In the following, the main contributions of the paper are highlighted:

- Constructing a novel hierarchical energy and reserve management system for islanded MGs including precise modelling of the frequency security requirements and through a newly efficient tractable MILP framework.
- Robust management of the hourly load and RES originated frequency excursions based on the IGDT method.
- Providing synergic participation of the DRPs in the MG hierarchical energy and frequency management system increasing the cost-effectiveness of the model.

The rest of the paper is divided into the following sections. Section III describes the detailed problem formulations and the principles of the IGDT-based methodology proposed for robust hierarchical energy and frequency management system.

TABLE I

COMPARISON OF THE PROPOSED MODEL WITH THE EXISTING APPROACHES

Reference	Uncertain Parameter			Uncertainty Modeling				Operational Constraints					
	RES	Load	Price	Stochastic	Probabilistic	Fuzzy	IGDT	RO	Islanding	DRP	Frequency Reserve	Commitment	MILP Unit-
[14]	*	*	*	*									
[15]	*	*	*		*			*					*
[16]	*	*	*					*	*				*
[17]	*	*	*			*							
[18]		*						*			*		
[19]		*		*				*		*	*		
[20]	*	*	*	*				*	*	*	*	*	*
[21]	*	*	*	*				*	*	*	*	*	*
Proposed Model	*	*	*	*			*	*	*	*	*	*	*

In Section IV, the proposed approach is implemented on a test MG, and the derived IGDT-based numerical results are evaluated over a 24-h time horizon corresponding to two uncertainty cases. Lastly, in Section V, some relevant conclusions are remarked.

III. PROBLEM FORMULATIONS

A. Hierarchical Energy and Frequency Management System

In the proposed hierarchical structure, the MGCC plays the most strategic role. Amounts of the scheduled energy and hierarchical regulation reserves as well as the related techno-economic set-points (P_{ref} and f_{ref}) are optimized by the MGCC and sent to the IIDGs and DRPs. The proposed primary controller measures local voltage and current. Referring to the available scheduled primary reserve capacity and on the basis of the characteristics of the droop controllers, the active power imbalances are managed automatically. Since the primary reserves are directly scheduled based on the MG frequency excursions, have a vindicate effect in limitation of the MG

frequency excursions. Worth mentioning that robust restoration process of the deviated frequency, in the result of inherent droop control features, is performed by the MGCC through altering the reference active power set-point as well as the commitment states of the IIDGs. Fig. 1, represents the proposed hierarchy in the islanded MG energy management system.

In the derived formulation, it is assumed that all the transients and oscillatory modes are damped. It is assumed that the MG frequency is settled into a steady-state equal point which is associated with the hourly frequency. It means that a definite power imbalance is assumed for every hour. Accordingly, an hourly frequency excursion can be extracted and included in to the day-ahead energy and reserve management problem. During the normal state, uncertainties are set as the forecasted values. When an imbalance occurs, the primary and secondary control levels are activated to mitigate the power imbalances. Notably, RESs are not participated in the proposed frequency management system.

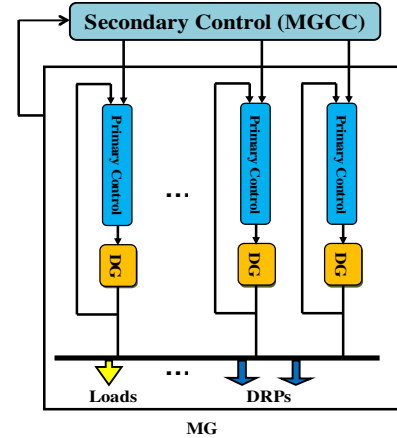

Fig. 1. Islanded MG hierarchical energy management system

The main aim of the MGCC is to minimize the Microgrid Total Cost (MTC) of the day-ahead operation. In addition, the MG operational planning should also ensure the associated frequency security restrictions. In this section, the detailed formulations relating to the deterministic energy and frequency management problem is given through the following expressions:

$$\min MTC = \min \sum_{t=1}^T \left[\sum_{g=1}^G (C_{gt}^E + C_{gt}^R) + C_t^{RES} + \sum_{d=1}^D C_{dt}^{DR} \right] \quad (1)$$

where,

$$C_{gt}^E = a_g \cdot u_{gt} + b_g \cdot P_{gt} + c_g^{sup} \cdot y_{gt} + c_g^{sdn} \cdot z_{gt}; \quad \forall t \in T, \forall g \in G \quad (2)$$

$$C_{gt}^R = \sum_{q \in Q} \sum_{k \in K} c_{gqk}^R \cdot R_{gkt}^q; \quad \forall t \in T, \forall g \in G \quad (3)$$

$$C_t^{RES} = c_w \cdot \sum_{w=1}^W P_{wt}^f + c_v \cdot \sum_{v=1}^V P_{vt}^f; \quad \forall t \in T \quad (4)$$

$$C_{dt}^{DR} = \sum_{n=1}^N c_{dn}^{DR} \cdot P_{dnt}; \quad \forall t \in T, \forall d \in D \quad (5)$$

Subject to:

$$\sum_{g=1}^G P_{gt} + \sum_{w=1}^W P_{wt}^f + \sum_{v=1}^V P_{vt}^f + \sum_{d=1}^D \sum_{n=1}^N P_{dnt} - P_{Lt}^f = 0; \quad (6)$$

$$\forall t \in T$$

$$\sum_{g=1}^G (P_{gt} + \Delta P_{gt}^q) + \sum_{w=1}^W (P_{wt}^f + \Delta P_{wt}^q) + \sum_{v=1}^V (P_{vt}^f + \Delta P_{vt}^q) + \sum_{d=1}^D \sum_{n=1}^N (P_{dnt} + \Delta P_{dnt}^q) - (P_{Lt}^f + \Delta P_{Lt}^q) = 0; \quad (7)$$

$$\forall t \in T, \forall q \in Q$$

$$u_{gt}^q \cdot \Delta f_t^q = m_{pg} \cdot (\Delta P_{gt}^{ref,q} - \Delta P_{gt}^q); \quad \forall t \in T, \forall q \in Q \quad (8)$$

$$|\Delta f_t^q| \leq \Delta f_{\max}^q; \quad \forall t \in T, \forall q \in Q \quad (9)$$

$$P_g^{\min} \cdot u_{gt} \leq P_{gt} \leq P_g^{\max} \cdot u_{gt}; \quad \forall t \in T \quad (10)$$

$$P_g^{\min} \cdot u_{gt}^q \leq P_{gt} + \Delta P_{gt}^q \leq P_g^{\max} \cdot u_{gt}^q; \quad \forall t \in T, \forall q \in Q \quad (11)$$

$$R_{gkt}^q \geq \Delta P_{gt}^q; \quad \forall t \in T, \forall q \in Q, \forall k = \text{upward} \quad (12)$$

$$R_{gkt}^q \geq -\Delta P_{gt}^q; \quad \forall t \in T, \forall q \in Q, \forall k = \text{downward} \quad (13)$$

$$P_{gt} - P_{g,t-1} \leq \text{ramp}_g^{\text{up}} \cdot (1 - y_{gt}) + \text{ramp}_g^{\text{sup}} \cdot y_{gt}; \quad \forall t \in T \quad (14)$$

$$P_{g,t-1} - P_{gt} \leq \text{ramp}_g^{\text{dn}} \cdot (1 - z_{gt}) + \text{ramp}_g^{\text{sdn}} \cdot z_{gt}; \quad \forall t \in T \quad (15)$$

$$y_{gt} - z_{gt} - u_{gt} + u_{g,t-1} = 0; \quad \forall t \in T, \forall g \in G \quad (16)$$

$$y_{gt} + z_{gt} - 1 \leq 0; \quad \forall t \in T, \forall g \in G \quad (17)$$

$$\phi_d^{\min} \leq P_{dn} \leq \phi_{dn}; \quad \forall d \in D, \forall n = 1 \quad (18)$$

$$0 \leq P_{dn} \leq \phi_{dn} - \phi_{d,n-1}; \quad \forall d \in D, \forall n = 2, 3, \dots, N \quad (19)$$

$$P_{dt} = \sum_{n=1}^N P_{dnt}; \quad \forall t \in T, \forall d \in D \quad (20)$$

$$\phi_d^{\min} \leq P_{dt} \leq \phi_d^{\max}; \quad \forall t \in T, \forall d \in D \quad (21)$$

$$\phi_d^{\min} \leq P_{dt} + \sum_{n=1}^N \Delta P_{dnt}^q \leq \phi_d^{\max}; \quad \forall t \in T, \forall d \in D, \forall q \in Q \quad (22)$$

MTC as the primary objective of the proposed energy management problem has been expressed in (1) and aimed to be minimized in a 24 hour scheduling period. It consists of the basic cost functions corresponding to the energy and reserve costs of the IIDGs, RESs and DRPs. Equation (2), states the linear hourly IIDG operation cost function including the start-up and shut-down costs. The cost of scheduled hierarchical upward and/or downward reserves for every IIDG is retained by (3). Hourly cost for penetrating RESs into the MG is shown in (4). Notably, the owner of all the IIDGs and RESs is the MGCC. In (5) costs related to the active participation of the DRPs into energy procurement services, have been retained. Indeed, the DRPs aggregate the end-users load curtailment offers and submit them as a price-demand package to the MGCC. DRPs are called when the MGCC decides to utilize their submitted load reduction into the energy and frequency

management structure. In this paper, due to requirements of the instantaneous primary control actions and their uncomfortable impacts on the MG end-users, it is assumed that DRPs can be participated in the provision of the energy and only the secondary control services.

Constraints (6) and (7) represent the hourly power balances in the normal and imbalance states, respectively. In (7), any changes in the MG load consumption or RES power output caused the committed IIDGs and participated DRPs to manage the occurred imbalance. Constraint (8) states the general frequency dependent behavior of the droop controlled IIDGs at the both primary and secondary control levels. Noteworthy, at the primary level, there is not enough time for the MGCC to change the commitment state and the reference set-points of the IIDGs. Therefore, $\Delta P_{gt}^{ref,q} = 0; \forall q = pri$. Whereas, in the secondary control level, the MGCC has more freedom and to restore the frequency to its nominal value (i.e. $\Delta f_t^q = 0; \forall q = sec$), authorizes to modify either the reference set-points of the IIDGs or even the commitment states of the dispatched IIDGs. In this paper, it is assumed that the frequency restoration procedure is performed by optimal modification of active power set-points. Constraint (9) ensures that the MG frequency excursions are managed securely. The maximum allowable frequency excursion restriction (Δf_{\max}^q) is enforced by the MGCC according to the MG operational targets. Usually, in the secondary control level, the upper-frequency excursion limit is set to be zero. The active power generation physical limitations of the IIDGs associate with the normal and imbalance states have been reflected in (10) and (11). Constraints (12) and (13) are presenting the technical limitations of the associated primary and secondary upward and downward reserves. Constraints (14)-(17) demonstrating ramp-up and ramp-down behavior of the committed IIDGs. These constraints implicate that how much a generating unit is allowed to change its output during a definite time interval. Constraints (18)-(22) describe the aforementioned step-wise price-demand offering package. For this purpose, the employed demand response program can be classified as demand bidding and ancillary service ones. ϕ_d^{\min} is the minimum acceptable offer that can be carried out by the DRPs and ϕ_d^{\max} is the sum of the all demand reduction offerings.

Clearly, constraints (8) and (9), make the model behave as a Mixed Integer Non-Linear Programming (MINLP) one. To ensure the optimality of the derived solution, it is proposed to efficiently solve the problem using an accurate equivalent MILP model. In (8), assuming that $\Delta f_{\min}^q \leq \Delta f_t^q \leq \Delta f_{\max}^q$ the product of $u_{gt}^q \cdot \Delta f_t^q$ as the non-linear term, is denoted by a new continuous variable v_t^q . The equivalent linear model of (8) can be replaced by [27]:

$$u_{gt}^q \cdot \Delta f_{\min}^q \leq v_t^q \leq u_{gt}^q \cdot \Delta f_{\max}^q; \quad \forall t \in T, \forall q \in Q \quad (23)$$

$$0 \leq \Delta f_t^q - v_t^q \leq (1 - u_{gt}^q) \cdot \Delta f_{\max}^q; \quad \forall t \in T, \forall q \in Q \quad (24)$$

Likewise, (9) can be modelled linearly using the proposed

formulation stated as:

$$x_t^q = \begin{cases} 1, & \text{if } \Delta f_t^q \leq 0 \\ 0, & \text{if } \Delta f_t^q > 0 \end{cases}, \quad \forall t \in T, \forall q \in Q \quad (25)$$

$$-\frac{\Delta f_t^q}{M} \leq x_t^q \leq 1 - \frac{\Delta f_t^q}{M}; \quad \forall t \in T, \forall q \in Q \quad (26)$$

where, M is a large enough constant and w_t^q and x_t^q are new auxiliary continuous and binary variables, respectively which accomplish the following constraints:

$$0 \leq w_t^q - \Delta f_t^q \leq -2x_t^q \Delta f_{\min}; \quad \forall t \in T, \forall q \in Q \quad (27)$$

$$0 \leq w_t^q + \Delta f_t^q \leq 2(1 - x_t^q) \Delta f_{\max}; \quad \forall t \in T, \forall q \in Q \quad (28)$$

With Δf_t^q is positive, (26) enforces $x_t^q = 0$ and consequently (27) implies that $w_t^q = \Delta f_t^q$ by which (28) is concurrently satisfied. While Δf_t^q is not positive, (26) makes the $x_t^q = 1$ and therefore (28) implies that $w_t^q = -\Delta f_t^q$ by which (27) is concurrently verified.

B. Robust IGDT-based Model Description

Due to the high uncertainty degrees that islanded MGs are faced, provision a robust and proficient uncertainty handling framework has a great necessity. Probabilistic-based uncertainty modeling frameworks, suffer from some drawbacks such as less tractable solutions, distribution dependency and high computational efforts. To cope with these shortcomings, particularly, in confronting to the severe uncertainties, IGDT as an informed, exact, simple and reliable decision making tool is proposed. The IGDT procures efficient, high priority, risk-aware and immunized solutions which are attained by modeling the discrepancy between real-world and associated forecasted errors [22]-[26]. In gist, tolerating with the most feasible uncertainty margins, while maintaining the system performance robustly is the major achievement of the IGDT.

In the IGDT framework, the uncertainties can be portrayed as a function of the forecasted values. Accordingly, in this paper, due to the capability of the IGDT envelope-bound uncertainty modelling technique in facing with forecasted type uncertainty sources, it is employed to model the load and RES uncertainties [22]. The implemented envelope-bound uncertainty model is represented as follows:

$$U(\alpha_\Omega, \tilde{\Omega}) = \left\{ \Omega : \left| \frac{\Omega - \tilde{\Omega}}{\tilde{\Omega}} \right| \leq \alpha_\Omega \right\}, \alpha_\Omega \geq 0 \quad (29)$$

where, Ω and $\tilde{\Omega}$ indicating the uncertain variable and its forecasted value, respectively. Variable α_Ω presents the extent of the variations and determines the model robustness. Higher values of α_Ω , stand for larger model robustness. The uncertainty model, $U(\alpha_\Omega, \tilde{\Omega})$, reveals the information associated with the uncertain variable. It implicates the gap between the known values and what is required to be known. The envelope-bound model can be rearranged as:

$$U(\alpha_\Omega, \tilde{\Omega}) = \left\{ \Delta\Omega : -\alpha_\Omega \tilde{\Omega} \leq \Delta\Omega \leq \alpha_\Omega \tilde{\Omega} \right\}, \alpha_\Omega \geq 0 \quad (30)$$

$$\Delta\Omega \in U(\alpha_\Omega, \tilde{\Omega})$$

where, variable $\Delta\Omega = \Omega - \tilde{\Omega}$ states the restricted deviation of the uncertain variable from its forecasted value. According to (30), the range of the uncertainty is determined by $\alpha_\Omega \tilde{\Omega}$.

In this paper, the uncertainties of the load consumption and RES output power are modelled and managed using IGDT-based formulation.

To develop the IGDT-based formulation, it is first assumed that there is only the load fluctuation is taken into account. The problem is a two level optimization model as portrayed through (31) and (32) which cannot be directly optimized via the existing commercial solvers:

$$\alpha_l(X, MTC_0) = \max_X \left\{ \alpha_l : \max_{\Delta P_{L_t}^q \in U(\alpha_l, P_{L_t}^f)} RMTC(X, U) \leq (1 + \sigma) MTC_0 \right\} \quad (31)$$

Subject to:

$$-\alpha_l P_{L_t}^f \leq \Delta P_{L_t}^q \leq \alpha_l P_{L_t}^f, \quad \forall t \in T, \forall q \in Q \quad (32)$$

$$\Delta P_{wt}^q = 0; \quad \forall t \in T, \forall q \in Q \quad (33)$$

$$\Delta P_{vt}^q = 0; \quad \forall t \in T, \forall q \in Q$$

The robustness function, $\alpha_l(X, MTC_0)$, is tailored to find out the maximum permissible load fluctuations while the maximum expected MTC could be attained. In other words, the objective is to specify the frequency excursions and consequently hierarchical reserve scheduling, by maximizing the possible range of the load variations ensuring the pre-defined RMTC. The RMTC can be controlled by σ , as the Uncertainty Budget (UB) of the robustness function. Higher value of UB indicates riskier performance.

The optimization problem given in (31) is bi-level, since it has two optimization levels. The outer level is aimed to maximize the confidence level of the load consumption uncertainty (i.e. α_l) that would satisfy the pre-specified total operational cost $((1 + \sigma) MTC_0)$. The inner one aims to find out the worst case load fluctuations which lead to a maximum cost. Thus, on the inner level, the decision variable is $\Delta P_{L_t}^q$. Fortunately, since the Δf_t^q as the decision variable of the outer level is determined based on the $\Delta P_{L_t}^q$, it can be considered as a constant parameter at the inner level. Hence, the equivalent single-level problem can be recast as the following:"

$$\max_X \alpha_l \quad (34)$$

Subject to:

$$RMTC \leq (1 + \sigma) MTC_0 \quad (35)$$

$$(1) - (28), (33)$$

$$\Delta P_{L_t}^q = \begin{cases} \alpha_l P_{L_t}^f, & \text{if } \Delta f_t^q \leq 0 \\ -\alpha_l P_{L_t}^f, & \text{if } \Delta f_t^q > 0 \end{cases}, \forall t \in T, \forall q \in Q \quad (36)$$

To accurately consider the interdependent relation between the load fluctuations and the corresponding MG frequency excursions, constraint (36) has been described. In plain language, (36) indicates that when the frequency drop from its

normal state set-point, it means that the MG load consumption has been increased within $\alpha_l \cdot P_{L_t}^f$. Vice-versa, a decrease in the MG load consumption causes the frequency to rise.

Observably (36) is in implicit form which cannot effectively solved via existing solvers [27]. To convert (36) to an efficient explicit linear form, the pre-defined auxiliary binary variable x_t^q and the corresponding constraints described in (25)-(26) should be applied in addition to the following constraints which ensuring the linearity:

$$0 \leq \Delta P_{L_t}^q + \alpha_l \cdot P_{L_t}^f \leq x_t^q \cdot M; \quad \forall t \in T, \forall q \in Q \quad (37)$$

$$-(1 - x_t^q) \cdot M \leq \Delta P_{L_t}^q - \alpha_l \cdot P_{L_t}^f \leq 0; \quad \forall t \in T, \forall q \in Q \quad (38)$$

Evidently, with $x_t^q = 0$ (i.e. $\Delta f_t^q > 0$), (37) enforces $\Delta P_{L_t}^q = -\alpha_l \cdot P_{L_t}^f$ which also satisfies (38). With $x_t^q = 1$, (38) yields to $\Delta P_{L_t}^q = \alpha_l \cdot P_{L_t}^f$, by which (37) is confirmed.

An analogous IGDT-based robust formulation can be exerted for the conditions only the RESs (aggregated Wind Turbines (WTs) and Photovoltaic units (PVs)) output power uncertainties are taken into account. The developed single-level MILP formulation, in this case, is characterized by the following expressions:

$$\max_X \alpha_{res} \quad (39)$$

Subject to:

$$RMTC \leq (1 + \sigma) \cdot MTC_0 \quad (40)$$

(1)–(28)

$$0 \leq (\Delta P_{wt}^q + \Delta P_{vt}^q) + \alpha_{res} \cdot (P_{wt}^f + P_{vt}^f) \leq x_t^q \cdot M; \quad \forall t \in T, \forall q \in Q \quad (41)$$

$$-(1 - x_t^q) \cdot M \leq (\Delta P_{wt}^q + \Delta P_{vt}^q) - \alpha_{res} \cdot (P_{wt}^f + P_{vt}^f) \leq 0; \quad \forall t \in T, \forall q \in Q \quad (42)$$

$$\Delta P_{L_t}^q = 0; \quad \forall t \in T, \forall q \in Q \quad (43)$$

In point of fact, constraints (25), (26) as well as (41), (42) are the MILP replacement of the following constraint:

$$\Delta P_{rest}^q = \begin{cases} \alpha_{res} \cdot (P_{wt}^f + P_{vt}^f), & \text{if } \Delta f_t^q \leq 0 \\ -\alpha_{res} \cdot (P_{wt}^f + P_{vt}^f), & \text{if } \Delta f_t^q > 0 \end{cases}, \quad (44)$$

$$\Delta P_{rest}^q = \Delta P_{wt}^q + \Delta P_{vt}^q; \quad \forall t \in T, \forall q \in Q$$

IV. SIMULATION RESULTS

In order to analyze the developed IGDT-based robust energy and frequency management portfolio, a typical islanded MG according to Fig. 1 has been implemented. The test MG includes 5 droop-controlled IIDGs and 2 DRPs. The proposed hierarchical frequency management paradigm is revealed in Fig. 2. The technical and economic data of the MG resources, the forecasted values of the load consumption and RESs and characteristics of DRPs' offering packages are illustrated in Table II and Fig. 3 and Table III, respectively [20], [28]. The formulations have been performed on a platform with Intel Core 2 Duo CPU (Central Processing Unit) and 4 GB of RAM. The proposed MILP model is solved using CPLEX under the GAMS environment [29]. In this paper, the

maximum allowable frequency excursion is set in ± 300 mHz according to the IEEE Std-1547 [30]. The operational costs related to WTs and PVs participation are 100.63 and 540.84 \$/MWh, respectively. In addition, it is assumed that all the IIDGs and RESs are operating at fixed unity power factor and reactive power requirements have been technically ensured. It should be noted that the amount of the MTC_0 has been calculated as 74768\$. In the followings, the IGDT methodology is applied to the considered MG. The IGDT-based numerical results and associated analyses are extracted thoroughly in two case-studies. Additionally, some profoundly discussions concerning the model verification are derived.

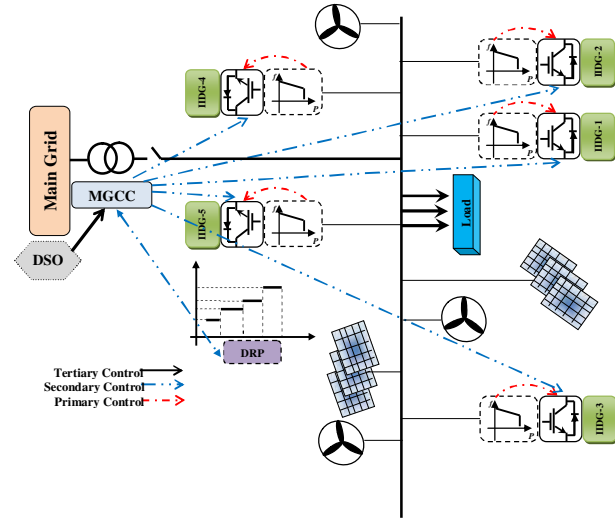

Fig. 2. A typical microgrid test system with the proposed hierarchical energy management system

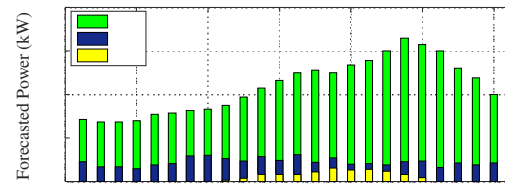

Fig. 3. Forecasted values of MG load and RES

TABLE II
TECHNO-ECONOMIC CHARACTERISTICS OF IIDGS

	IIDG1	IIDG2	IIDG3	IIDG4	IIDG5
P_g^{\min} (kW)	30	50	20	30	35
P_g^{\max} (kW)	150	150	100	100	200
a_g (\$/h)	0.85	0.85	2.55	2.55	2.12
b_g (\$/MWh)	40.37	40.37	20.84	20.84	30.12
c_g^{\sup} (\$)	0.09	0.09	0.16	0.16	0.12
c_g^{sdn} (\$)	0.08	0.08	0.09	0.09	0.08
$c_{dqk}^R _{q=pri}$ (\$/MWh)	60	60	40	40	30.80
$c_{dqk}^R _{q=sec}$ (\$/MWh)	20.10	20.10	10.50	10.50	10.70
$ramp_g^{\sup/dn}$ (kW)	100	100	100	100	150
$ramp_g^{\sup/sdn}$ (kW)	150	150	100	100	200
m_{pg} (mHz/kW)	10	10	15	15	7.50

TABLE III
DRPS OFFER PACKAGES

DRP1	Demand (kW)	0-25	25-65	65-95	95-120
	Offered Price (\$)	0.3	0.48	0.60	0.75
DRP2	Demand (kW)	0-40	40-60	60-85	85-135
	Offered Price (\$)	0.25	0.45	0.65	0.80

A. Case 1- Robust energy management considering load consumption uncertainty

This case focuses on only the whole MG load fluctuations. The optimization problem is solved for different values of the uncertainty budget (σ). The performance of the robustness variable is assessed in response to increasing changes in σ and subjected to various RMTCs, which is depicted in Fig. 4. As it can be seen, changes of σ in the range of 0.01 to 0.2 causes α_l to be increased from 0.133 to 0.209. For the uncertainty budgets greater than 0.2, the MG operational constraints do not authorise the robustness variable to become larger. In other words, the upper limit of the MG robustness against the load fluctuations is about 0.209 of its forecasted value, which is corresponding to RMTC within 89722\$. As it is represented by Fig. 4(b), the values of the RMTC are increased with the increase in the robustness degree of the MG.

For a detailed analysis, the MG load fluctuations and the corresponding frequency excursions for two specific robustness functions (i.e. 0.139 and 0.209) are depicted in Fig. 5. The MGCC optimizes α_l in a way that RMTC is satisfied by the applied uncertainty budget. In other words, the MGCC manages the upward and downward reserves such that the optimistic RMTC is obtained. As a result, to properly manage reserve costs, both the negative and positive frequency excursions should be included in the energy management problem.

Obviously, in hours in which the MG encounters to the frequency drop, upward control reserves are activated to alleviate the occurred load growth. According to the Fig. 5(b), the MGCC can suitably manage the hourly frequency excursions within the secure range ± 300 mHz. Furthermore, the values of the primary active power increment and decrement corresponding to the droop-based IIDGs are displayed in Fig. 6. For instance, in Fig. 6(b), when the robustness value is 0.209, in hours 20 to 24, the values of the primary active power generations are lower than the dispatched energy. It means that the load consumption has been decreased from its forecasted value, the MG frequency raised and consequently, downward reserves have been activated.

B. Robust energy management considering aggregated RES output uncertainty

The behaviors of the corresponding robustness function (α_{res}), versus the changes of uncertainty budget (σ), as well as the variations of the RMTC in response to α_{res} are portrayed in Fig. 7. Similar to Case 1, when the uncertainty budget equals to 0.2, the robustness function and the RMTC values are obtained as 0.811 and 89722\$. For the uncertainty budgets greater than 0.2, the corresponding values of α_{res} and RMTC

are saturated and remained constant. Besides, amounts of the RES deviations compared to the forecasted values and the MG hourly frequency excursions for two particular robustness functions (i.e. 0.531 and 0.741) are depicted in Fig. 8.

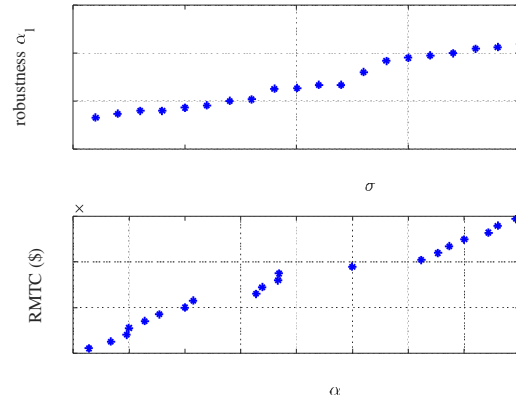

Fig. 4. Variations of (a) Load robustness index versus uncertainty budget (b) RMTC versus load robustness index

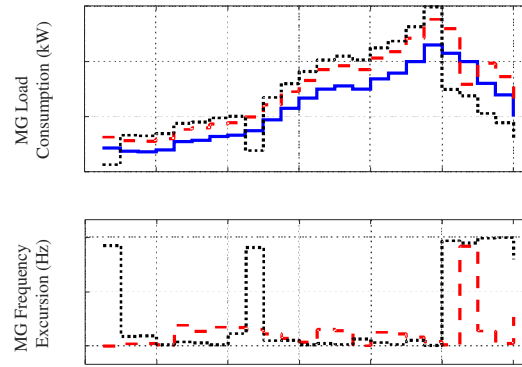

Fig. 5. Variations of MG (a) Load consumption and (b) Frequency excursion in Case 1: Solid (forecasted load), Dashed ($\alpha_l = 0.139$), Dotted ($\alpha_l = 0.209$).

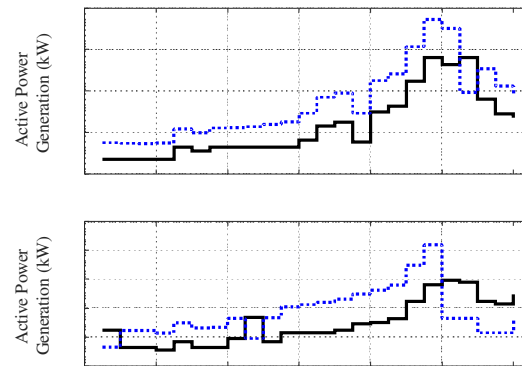

Fig. 6. Active power generation values associate with (a) $\alpha_l = 0.139$ and (b) $\alpha_l = 0.209$: Solid (Normal state) and Dotted (Primary level)

C. Discussions

In this section, to demonstrate the effectiveness of the proposed IGDT-based contributions and verify the attained numerical results, some profound discussions are presented. To assess the impacts of the frequency security constraints on the MG energy management system, the results of a specific uncertainty budget ($UB = 0.03$), are compared to the cases where frequency is not regarded. The breakdown of the day-ahead operational costs is listed in Table. IV.

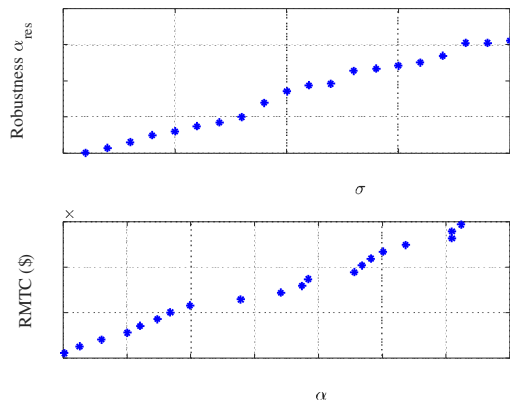

Fig. 7. Variations of (a) RES robustness index versus uncertainty budget (b) RMTC versus RES robustness index

Observably, in both Case 1 and Case 2, when the frequency is considered, the cost associate with the primary reserves are increased which is ensures the MG frequency security. In other words, this is the cost relating to the MG frequency insurance.

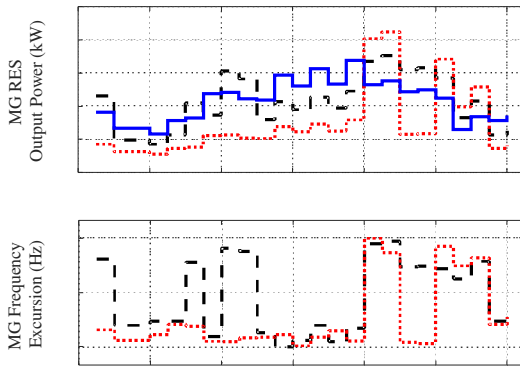

Fig. 8. Variations of MG (a) RES output and (b) Frequency excursion in case 2: Solid (forecasted RES), Dashed ($\alpha_{res} = 0.531$), Dotted ($\alpha_{res} = 0.741$).

TABLE IV

BREAKDOWN OF MG DAILY TECHNO-ECONOMIC INDICES WITH/WITHOUT FREQUENCY CONSTRAINTS

Case ($\sigma = 0.03$)		Case 1		Case 2	
Frequency Model		With	without	with	without
Robustness (α)		0.139	0.089	0.531	0.403
Operational Cost (\$)	Energy	18326.5	25560.8	18748.5	25525.3
	Primary Reserve	7013.8	-	6195.1	-
	Secondary Reserve	2524.8	2655.3	2299.4	2446.4
	Demand Response	2582.6	1513.1	2423.1	1557.5
	RMTC	77011.7	76166.3	76864.1	75966.7

Moreover, the costs associate with the energy and secondary reserves are decreased in the cases the frequency is included. Since the MGCC is obliged to manage the MG frequency in the pre-specified secure range (i.e., ± 300 mHz), more droop-controlled IIDGs, particularly those with larger droop coefficients, are committed to preserve the MG adequate droop stack. To affirm the numerical results, the IGDT-based unit-commitment states in Case 1 and Case 2 are depicted in Fig. 9 and compared with the cases there is no frequency restriction.

In contrast, when the frequency is not taken into account, fewer IIDGs are ON (Figs. 9(b) and 9(d)), which will be scheduled closer to their maximum capacity. Moreover, unlike the primary reserves, the amounts of the scheduled secondary reserves are not restricted with the frequency excursions and can be scheduled more plentiful.

The scheduled primary and secondary frequency control reserves associated with $UB=0.03$, in Case 1 and Case 2, are represented in Fig. 10 and Fig. 11, respectively. The upward and downward reserves are corresponding to the negative and positive frequency excursions, respectively. Obviously, in the secondary control level, the MGCC can change the commitment state of the generating units. It is tried to supply the secondary reserves from the inexpensive IIDGs like IIDG5. The IGDT-based reserve scheduling results corresponding to the frequency-independent energy management model are depicted in Fig. 12. Clearly, the committed IIDGs and their scheduled reserves are distinctive to the ones presented in frequency dependent model.

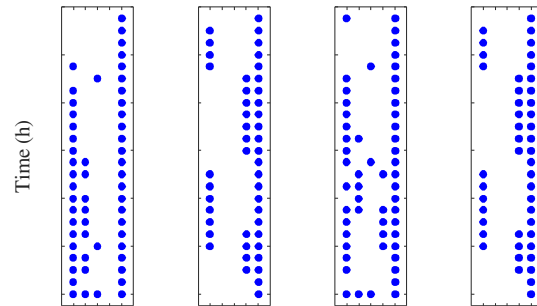

Fig. 9. Scheduled IIDG unit commitment states with and without frequency in case 1 (a), (b) and case 2 (c), (d). ($UB = 0.03$)

Furthermore, to demonstrate the techno-economic effects of the DRPs, the operational costs in Case 1 and Case 2, are compared with the corresponding cases the DRPs are neglected. In all the cases, the uncertainty budget is set at 0.2. The breakdown of the costs with/without consideration of the DRPs is represented in Table V. Observably, taking the DRPs into account, reduces the operational costs associated with the energy and secondary reserves. It is because of that the MGCC utilizes the DRPs in procuring the energy requirements coordinated with the droop controlled IIDGs. Accordingly, the capacities of the IIDGs become free. Therefore, not only the MG day-ahead energy costs are decreased, but also the MGCC has this opportunity to provide the secondary reserves by the dispatching the inexpensive IIDGs. Noticeably, the associated primary reserve costs are increased when the DRPs are incorporated into the model. Since the MGCC relies on the capability of the DRPs in supplying the hourly energy demands, consequently, in some hours the expensive IIDGs are not committed. As a result, the droop stack of the whole MG in that hours become less which leads to the higher frequency excursions and therefore the more primary reserves are scheduled which increases the associated costs. Although the frequency excursion may be more severe in the cases the DRPs are included, it has been robustly managed in the pre-defined secure range. On the whole, the RMTCs are decreased significantly by considering the DRPs.

Additionally, to provide a methodology verification portfolio, a through analytic-numerical comparison is developed. Comparing to the other uncertainty handling techniques and focusing on their particular pros and cons, it can be said that there is no full-fledged modeling technique in the face of uncertain inputs. Comparatively, the IGDT has not required the exact definition of the uncertainty set. It only attempts to provide resilient decision makings against the given uncertainties. In contrast, the probabilistic or fuzzy methods need near-accurate information about the treatment of uncertain inputs. Likewise, the robust optimization method relies on a precise uncertainty horizon belonging to the inputs [26]. In this paper, to vindicate the impressiveness of the proposed IGDT-based method, in robust handling the MG uncertainties, a scenario based stochastic programming optimization methodology has also been applied to the energy management problem.

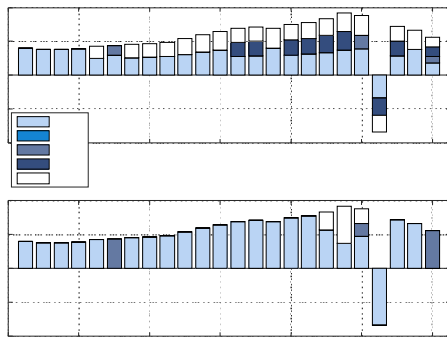

Fig. 10. Scheduled MG (a) primary and (b) secondary reserves in case 1 with $\alpha_1 = 0.139$

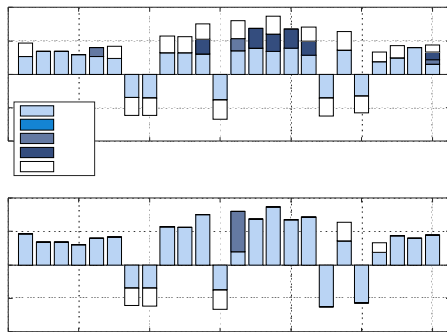

Fig. 11. Scheduled MG (a) primary and (b) secondary reserves in case 2 with $\alpha_{res} = 0.531$

In this regard, first, 1000 random scenarios corresponding to the load consumption and RES output have been generated using Monte Carlo Simulation (MCS) technique and reduced efficiently after applying a scenario reduction algorithm. Fig. 13, shows total operational costs of the MG day-ahead energy management problem using both stochastic and IGDT-based optimization methods. The simulation results in 10 reduced scenarios are compared with the results associate with the two uncertainty budgets. As it can be interpreted from Fig. 13, for $UB=0.03$, it seems the MGCC decision making is an economic one, while it is more conservative for $UB=0.20$. Meanwhile, to verify the IGDT-based simulation results, a MCS-based verification is executed.

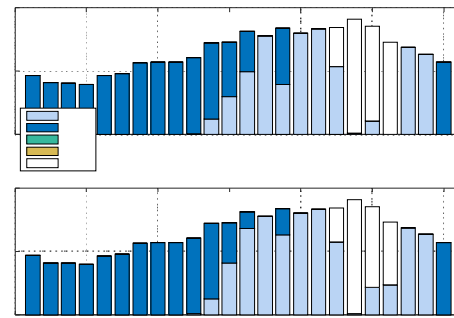

Fig. 12. Scheduled MG reserve resources without considering frequency excursions for $UB=0.03$: (a) case 1 and (b) case 2

TABLE V
BREAKDOWN OF MG ECONOMIC INDICES WITH/WITHOUT DRPS

Case ($\sigma = 0.20$)	Case 1		Case 2		
	With DRPs	Without DRPs	With DRPs	Without DRPs	
Robustness (a)	0.2092	0.2048	0.8115	0.8290	
Operational Cost (\$)	Energy	26704.3	44136.1	27682.7	45456.7
	Primary Reserve	10475.8	10187.8	10032.6	9998.4
	Secondary Reserve	3736.4	4266.3	3434.7	3860.6
	Demand Response	2100.9	-	1893.4	-
	RMTC	89722.4	105466.2	89722.4	106079.7

The results of 1000 generated scenarios using MCS are compared with the IGDT results for Case 1 and Case 2 in Fig. 14 and Fig. 15, respectively. The average values of the MCS for Case 1 and Case 2 are 81947.5 and 81161.9 \$, respectively which proof the economic and conservative behavior of $UB=0.03$ and $UB=0.20$ decisions, respectively.

Noteworthy, except the relying on the input probability distribution function, the scenario-based stochastic optimization models suffer from some substantial drawbacks. For instance, the accuracy of the stochastic method is highly dependent to the scenarios, or some of the scenarios are over-estimating and will never occur in reality [26]. Although larger number of the scenarios causes the more reliable decision makings, increasing the number of scenarios critically intensifies the computational burden of the problem. Furthermore, stochastic models cannot give the MGCC a confidence level concerning the total operational costs which can be simply attained through the IGDT.

V. CONCLUSION

To cope with frequency excursions of the islanded microgrids arisen from its small scale, inertia-less and high intermittent energy delivery environment, an efficient MILP-based hierarchical joint energy and frequency management structure has been proposed. The approach has been tailored to employ a robust and reliable uncertainty handling strategy without relying on probability distribution functions. A precise envelope based IGDT has been applied to energy and hierarchical reserve management framework and solved optimistically. Simulation results demonstrate that by proper scheduling droop controlled IIDGs and DRPs, the MGCC can reconcile between economic and security targets. Moreover, using the IGDT methodology helps the MGCC conquering the MG severe uncertainties by procuring immunized solutions in

accordance to changeable uncertainty budgets utilizing an envelope based robust IGDT-based technique.

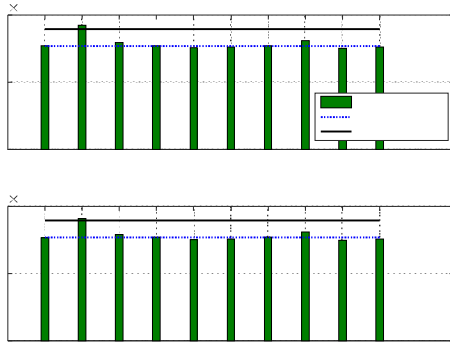

Fig. 13. MG total operational cost in stochastic and IGDT-based optimization models: (a) Case 1 and (b) Case 2

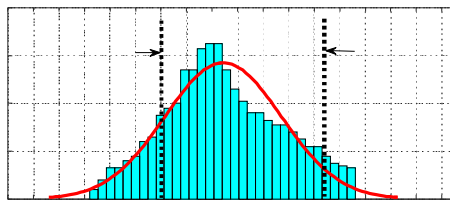

Fig. 14. MG total operational cost using MCS and IGDT in Case 1

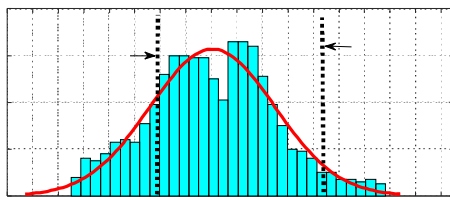

Fig. 15. MG total operational cost using MCS and IGDT in Case 2

REFERENCES

- [1] F. D. Galiana, F. Bouffard, J. M. Arroyo, J. F. Restrepo, "Scheduling and pricing of coupled energy and primary, secondary and tertiary reserves", *Proceedings of IEEE*, Vol. 93, No. 11, pp. 1970-83, 2005.
- [2] S. Jadid, P. Rabbanifar, "Stochastic multi-objective frequency control in joint energy and reserve markets considering power system security", *IET Generation, Transmission and Distribution*, Vol. 7, No. 1, pp. 76-89, 2013.
- [3] F. Katiraei, R. Irvani, N. Hatzigiorgiou, A. Dimeas, "Micro-grids management", *IEEE Power Energy Magazine*, Vol. 6, No. 3, pp. 54-65, 2008.
- [4] T. L. Vandoorn, J. C. Vasquez, J. D. Kooning, J. M. Guerrero, L. Vandeveld, "Micro-grids: Hierarchical control and an overview of the control and reserve management strategies", *IEEE Industrial Electronics Magazine*, pp. 42-55, 2013.
- [5] J. M. Guerrero, J. C. Vasquez, J. Matas, L. G. de Vicuna, M. Castilla, "Hierarchical control of droop-controlled AC and DC micro-grids—a general approach toward standardization", *IEEE Transactions on Industrial Electronics*, Vol. 58, No. 1, pp. 387-405, 2011.
- [6] J. Rocabert, A. Luna, F. Blaabjerg, P. Rodriguez, "Control of power converters in AC micro-grids", *IEEE Transactions on Power Electronics*, Vol. 27, No. 11, pp. 4734-4749, 2012.
- [7] J. M. Guerrero, M. Chandorkar, T. L. Lee, P. C. Loh, "Advanced control architectures for intelligent microgrids-Part I: Decentralized and hierarchical control", *IEEE Transactions on Industrial Electronics*, Vol. 60, No. 4, pp. 1254-1262, 2013.
- [8] C. A. Canizares, R. Palma-Pehnke, "Trends in microgrid control-IEEE task force on microgrid control", *IEEE Transactions on Smart Grid*, Vol. 5, No. 4, pp. 1905-1919, 2014.
- [9] J. A. P. Lopez, C. L. Moreira, A. G. Madureira, "Defining control strategies for micro-grids islanded operation", *IEEE Transactions on Power Systems*, Vol. 21, No. 2, pp. 916-924, 2006.
- [10] A. Mohd, E. Ortjohann, D. Morton, O. Omari, "Review of control techniques for inverter parallel operation", *Electric Power Systems Research*, Vol. 80, No. 12, pp. 1477-1487, 2010.
- [11] K. De Brabandere, B. Bolsens, J. Van den Keybus, A. Woyte, J. Driesen, R. Belmans, "A voltage and frequency droop control method for parallel inverters", *IEEE Transactions on Power Electronics*, Vol. 22, No. 4, pp. 1107-1115, 2007.
- [12] E. Pashajavid, F. Shahnia, A. Ghosh, "Development of a self-healing strategy to enhance the overloading resilience of islanded microgrids", *IEEE Transactions on Smart Grid*, Vol. 8, No. 2, pp. 868-880, 2015.
- [13] D. E. Olivares, C. A. Canizares, M. Kazerani, "A centralized energy management system for isolated microgrids", *IEEE Transactions on Smart Grids*, Vol. 5, No. 4, pp. 1864-1875, 2014.
- [14] T. Niknam, R. Azizpanah, M. R. Narimani, "An efficient scenario-based stochastic programming framework for multi-objective optimal microgrid operation", *Applied Energy*, Vol. 99, pp. 455-470, 2012.
- [15] S. A. Alavi, A. Ahmadian, M. Aliakbar-Golkar, "Optimal probabilistic energy management in a typical micro-grid based on robust optimization and point estimate method", *Energy Conversion and Management*, Vol. 95, pp. 314-325, 2015.
- [16] G. Liu, M. Strake, B. Xiao, K. Tomsovic, "Robust optimization-based microgrid scheduling with islanding constraints", *IET Generation, Transmission and Distribution*, Vol. 11, No. 7, pp. 1820-1828, 2017.
- [17] A. Chaouachi, R. M. Kamel, R. Andouli, K. Nagasaka, "Multiobjective intelligent energy management for a microgrid", *IEEE Transactions on Industrial Electronics*, Vol. 60, No. 4, pp. 1688-1699, 2013.
- [18] C. A. Hernandez-Aramburo, T. C. Green, N. Mugniot, "Fuel consumption minimization of a microgrid", *IEEE Transactions on Industrial Applications*, Vol. 41, No. 3, pp. 673-681, 2005.
- [19] S. Conti, R. Nicolosi, S. A. Rizzo, H. H. Zeineldin, "Optimal dispatching of distributed generators and storage systems for MV islanded microgrids", *IEEE Transactions on Power Delivery*, Vol. 27, No. 3, pp. 1243-1251, 2012.
- [20] N. Rezaei, M. Kalantar, "Stochastic frequency-security constrained energy and reserve management of an inverter interfaced islanded microgrid considering demand response programs", *International Journal of Electrical Power and Energy Systems*, Vol. 69, pp. 273-286, 2015.
- [21] N. Rezaei, M. Kalantar, "Economic-environmental hierarchical frequency management of a droop controlled islanded microgrid", *Energy Conversion and Management*, Vol. 88, pp. 498-515, 2014.
- [22] Y. Ben-Haim, *Info-gap Decision Theory: Decision Under Severe Uncertainty*. New York, NY, USA: Academic, 2006.
- [23] S. Shafiee, H. Zareipour, A. M. Knight, N. Amjadi, B. Mohammadi-Ivatloo, "Risk-constrained bidding and offering strategy for a merchant compressed air energy storage plant", *IEEE Transactions on Power Systems*, Vol. 32, No. 2, pp. 946-957, 2016.
- [24] S. Dehghan, A. Kazemi, N. Amjadi, "Multi-objective robust transmission expansion planning using information-gap decision theory and augmented ϵ -constraint method", *IET Generation, Transmission and Distribution*, Vol. 8, No. 5, pp. 828-840, 2014.
- [25] J. Aghaei, V. G. Agelidis, M. Charwand, F. Raesi, A. Ahmadi, A. Esmaeel Nezhad, A. Heidari, "Optimal robust unit commitment of CHP plants in electricity markets using information gap decision theory", *IEEE Transactions on Smart Grid*, Vol. 8, No. 5, pp. 2296-2304, 2017.
- [26] A. Soroudi, A. Rabiee, A. Keane, "Information gap decision theory approach to deal with wind power uncertainty in unit commitment", *Electric Power Systems Research*, Vol. 145, pp. 137-148, 2017.
- [27] J. F. Restrepo, F. D. Galiana, "Unit commitment primary frequency regulation constraints", *IEEE Transactions on Power Systems*, Vol. 20, No. 4, pp. 1836-1842, 2005.
- [28] A. G. Tsikalakis, N. D. Hatzigiorgiou, "Centralized control for optimizing micro-grids operation", *IEEE Transactions on Energy Conversion*, Vol. 23, No. 1, pp. 241-248, 2008.
- [29] Generalized Algebraic Modeling Systems (GAMS). <<http://www.GAMS.com>>.
- [30] IEEE Standard for interconnecting distributed resources to electric power systems, IEEE Standard 1547, 2003.



Navid Rezaei was born in Kurdistan, Iran on May 5, 1987. He received the B.Sc. degree from K. N. Toosi University of Technology, Tehran, Iran, in 2009, the M.Sc. and Ph.D. degrees both from Iran University of Science and Technology, Tehran, Iran, in

2011 and 2015, respectively, all in electrical engineering. He is currently an assistant professor with the Department of Electrical Engineering, University of Kurdistan, Sanandaj, Iran. His research interests include operation, planning and management of smart grids.

well, he received the best paper award of the Journal of Power Electronics in 2016.

In 2014, 2015, 2016, and 2017 he was awarded by Thomson Reuters as Highly Cited Researcher, and in 2015 he was elevated as IEEE Fellow for his contributions on “distributed power systems and microgrids.”



Abdollah Ahmadi received his B.Sc. from Shiraz University, Shiraz, Iran, in 2007 and his M.Sc. from Iran University of Science and Technology, Tehran, Iran, in 2011, both in Electrical Engineering. He is currently pursuing the Ph.D. degree with the School of Electrical Engineering and

Telecommunications, the University of New South Wales, Sydney, Australia.

He is the author of more than 50 international journal papers. His research interests include renewable energy systems, smart grids, electricity markets, and power system operation and restructuring.



Amirhossein Khazali received the B.Sc. from K. N. Toosi University of Technology, Tehran, Iran in 2007 and the M.Sc. and Ph.D. degrees from Iran University of Science and Technology (IUST), Tehran, Iran, in 2010 and 2015, respectively.

His research interests include power system operation, stability and renewable energy integration.



Josep M. Guerrero (S'01-M'04-SM'08-FM'15) received the B.S. degree in telecommunications engineering, the M.S. degree in electronics engineering, and the Ph.D. degree in power electronics from the Technical University of Catalonia, Barcelona, in 1997, 2000 and 2003, respectively. Since

2011, he has been a Full Professor with the Department of Energy Technology, Aalborg University, Denmark, where he is responsible for the Microgrid Research Program (www.microgrids.et.aau.dk). His research interests is oriented to different microgrid aspects. As